

TECHNICAL & SERVICE MANUAL

Series PLFY Ceiling Cassettes R407C / R22

Indoor unit
[Model names]

PLFY-P80VAM-A

PLFY-P100VAM-A

PLFY-P125VAM-A

[Service Ref.]

PLFY-P80VAM-A.UK
PLFY-P100VAM-A.UK
PLFY-P125VAM-A.UK

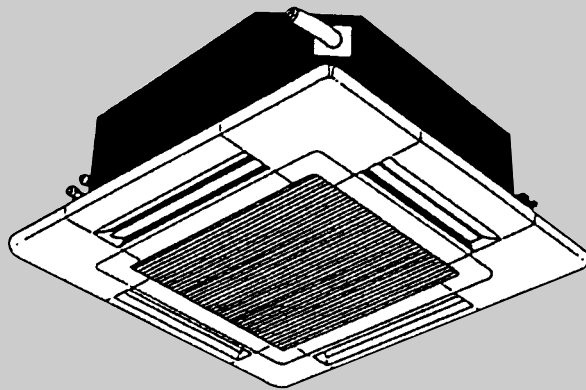

INDOOR UNIT

CONTENTS

1. SAFETY PRECAUTION	2
2. PART NAMES AND FUNCTIONS	4
3. SPECIFICATION	6
4. 4-WAY AIR FLOW SYSTEM	7
5. OUTLINES AND DIMENSIONS	10
6. WIRING DIAGRAM	11
7. REFRIGERANT SYSTEM DIAGRAM	12
8. TROUBLE SHOOTING	13
9. DISASSEMBLY PROCEDURE	18
10. PARTS LIST	21
11. OPTIONAL PARTS	Back cover

10

PARTS LIST

PANEL PARTS

PLFY-P80VAM-A.UK

PLFY-P100VAM-A.UK

PLFY-P125VAM-A.UK

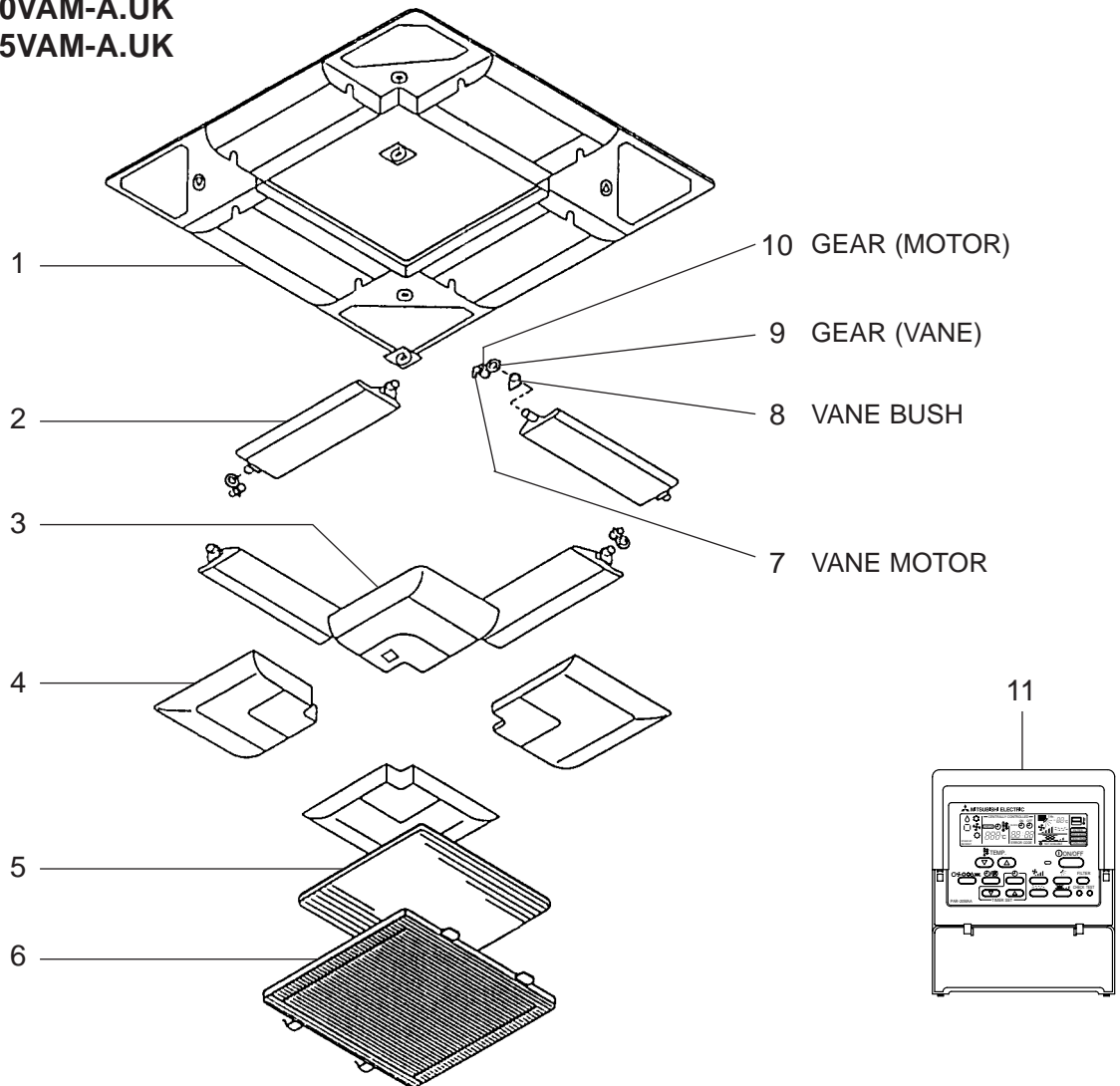

Part number that is circled is not shown in the figure.

No.	Part No.	Part Name	Specification	Q'ty/set	Remarks (Drawing No.)	Wiring Diagram Symbol	Recom- mended Q'ty	Price	
				PLFY- P80 / P100 / P125 VAM-A.UK				Unit	Amount
1	S70 E10 003	AIR OUTLET GRILLE		1					
2	S70 E00 002	VANE ASSY		4					
3	S70 E01 638	CORNER PANEL		1					
4	S70 E00 638	CORNER PANEL		3					
5	S70 E00 500	L.L. FILTER		1					
6	S70 E00 691	GRILLE ASSY		1					
7	S70 E00 223	VANE MOTOR		4		MV			
8	S70 E00 063	VANE BUSH		8					
9	S70 E00 040	GEAR (VANE)		4					
10	S70 E01 040	GEAR (MOTOR)		4					
11	S70 030 713	MA-REMOTE CONTROLLER	65WRC5	1	<PAR-20MAA>	R.B			
⑫	S70 E01 673	SCREW ASSY		1					

FUNCTIONAL PARTS
PLFY-P80VAM-A.UK
PLFY-P100VAM-A.UK
PLFY-P125VAM-A.UK

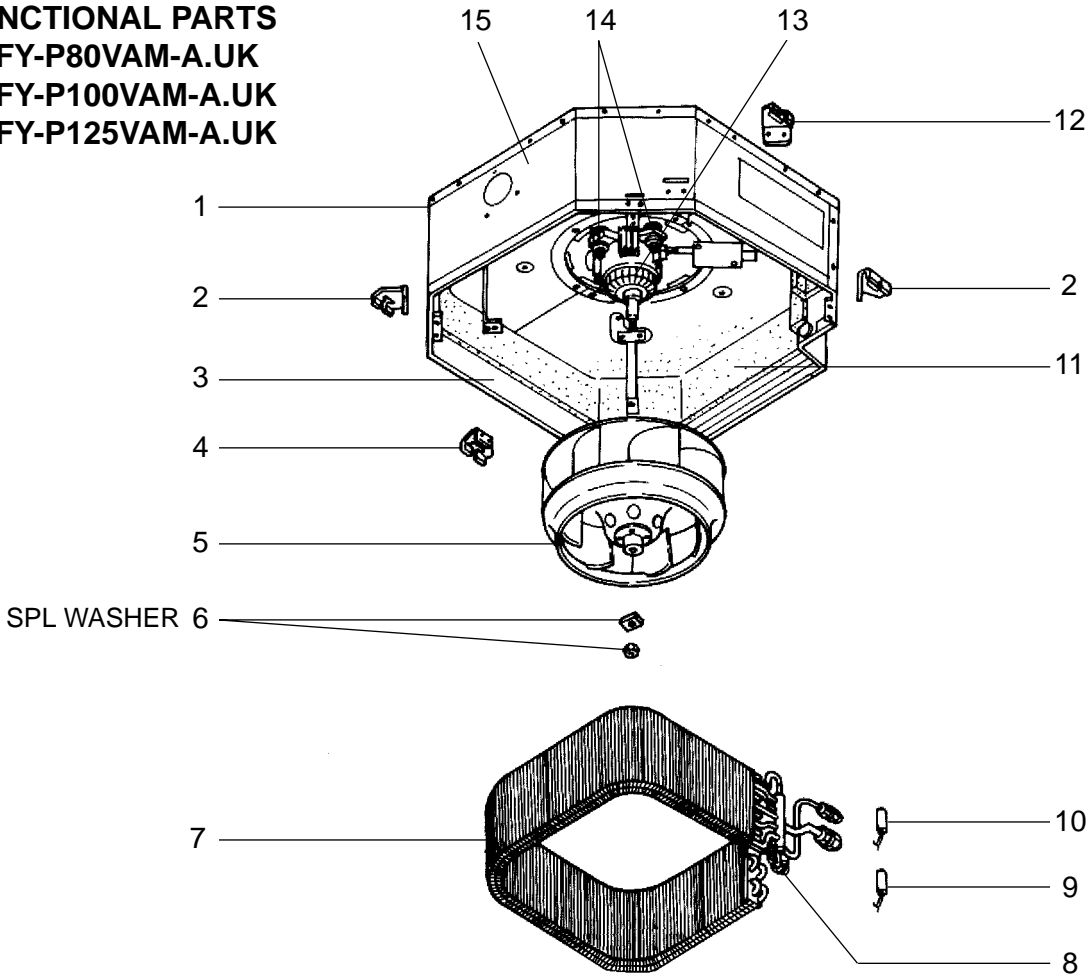

No.	Part No.	Part Name	Specification	Q'ty/set		Remarks (Drawing No.)	Wiring Diagram Symbol	Recom- mended Q'ty	Price	
				PLFY- · VAM-A.UK					Unit	Amount
				P80	P100/P125					
1	S70 003 687	BASE DWG		1	1					
2	S70 E01 130	LEG		2	2					
3	S70 005 688	DRUM 1 ASSY		1						
	S70 007 688	DRUM 1 ASSY			1					
4	S70 E02 130	LEG		1	1					
5	S70 E00 114	TURBO FAN		1						
	S70 E01 114	TURBO FAN			1					
6	S70 08K 097	SPL WASHER		1	1					
7	S70 E15 480	HEAT EXCHANGER		1						
	S70 E17 480	HEAT EXCHANGER			1					
8	S70 E08 401	LINEAR EXPANSION VALVE		1	1		LEV			
9	S70 79N 202	GAS PIPE THERMISTOR		1	1		TH23			
10	S70 17J 202	LIQUID PIPE THERMISTOR		1	1		TH22			
11	S70 E00 659	INNER COVER ASSY		1						
	S70 E02 659	INNER COVER ASSY			1					
12	S70 E00 130	LEG		1	1					
13	S70 E06 762	FAN MOTOR		1			MF			
	S70 E07 762	FAN MOTOR			1		MF			
14	S70 A41 105	MOTOR MOUNT		4	4					
15	S70 006 688	DRUM 2 ASSY		1						
	S70 008 688	DRUM 2 ASSY			1					

FUNCTIONAL PARTS
PLFY-P80VAM-A.UK
PLFY-P100VAM-A.UK
PLFY-P125VAM-A.UK

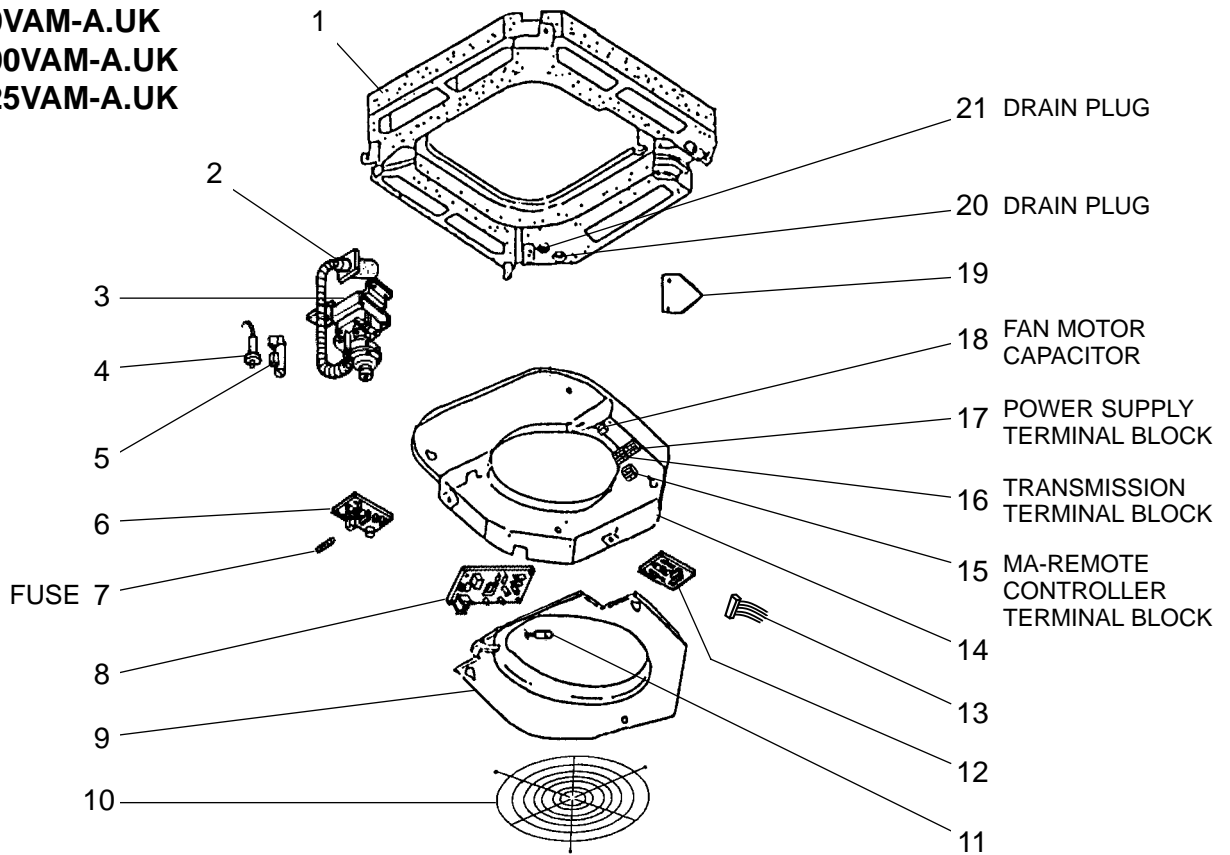

No.	Part No.	Part Name	Specification	Q'ty/set			Remarks (Drawing No.)	Wiring Diagram Symbol	Recom- mended Q'ty	Price	
				PLFY- . VAM-A.UK						Unit	Amount
				P80	P100	P125					
1	S70 E02 529	DRAIN PAN		1							
	S70 E00 529	DRAIN PAN			1	1					
2	S70 A41 523	DRAIN SOCKET		1	1	1	<PART OF DRAIN PUMP ASSY>				
3	S70 E01 355	DRAIN PUMP		1	1	1		DP			
4	S70 E00 266	DRAIN SENSOR		1	1	1		DS			
5	S70 31K 241	SENSOR HOLDER		1	1	1					
6	S70 E02 313	POWER BOARD		1	1	1		P.B			
7	S70 520 239	FUSE	250V 6.3A	1	1	1	<PART OF BOARD>	FUSE			
8	S70 E10 310	INDOOR CONTROLLER BOARD		1				I.B			
	S70 E11 310	INDOOR CONTROLLER BOARD			1			I.B			
	S70 E12 310	INDOOR CONTROLLER BOARD				1		I.B			
9	S70 003 503	BELL MOUTH (CONT. COVER ASSY)		1	1	1					
10	S70 E10 675	FAN GUARD		1	1	1					
11	S70 E00 202	ROOM TEMPERATURE THERMISTOR	1050XAP	1	1	1		TH21			
12	S70 B02 294	ADDRESS BOARD		1	1	1		A.B			
13	S70 E00 304	ADDRESS CABLE		1	1	1					
14	S70 E00 503	ELECTRICAL BOX COVER		1	1	1					
15	S70 512 716	MA-REMOTE CONTROLLER TERMINAL BLOCK	2P(1,2)	1	1	1		TB15			
16	S70 B02 716	TRANSMISSION TERMINAL BLOCK	3P(M1,M2,S)	1	1	1		TB5			
17	S70 521 716	POWER SUPPLY TERMINAL BLOCK	3P(L,N,⊕)	1	1	1		TB2			
18	S70 17T 255	FAN MOTOR CAPACITOR	3.5μF 440V	1				C			
	S70 E02 255	FAN MOTOR CAPACITOR	7.0μF 440V		1	1		C			
19	S70 001 663	CORNER COVER		1	1	1					
20	S70 A41 524	DRAIN PLUG		1	1	1					
21	S70 A48 524	DRAIN PLUG		1	1	1					