

Air-Conditioners For Building Application

INDOOR UNIT

PKFY-P·VGM-E

For use with the R410A, R407C & R22 Για χρήση με τα R410A, R407C και R22
Bei Verwendung von R410A, R407C & R22 Para utilização com o R410A, R407C e o R22
A utiliser avec le R410A, R407C et le R22 R410A, R407C ve R22 ile beraber kullanmak için
Bij gebruik van R410A, R407C & R22 Для использования с моделями R410A, R407C и R22
Para utilizar con el R410A, R407C y el R22 使用R410A, R407C和R22制冷剂
Uso del refrigerante R410A, R407C e R22

INSTALLATION MANUAL

For safe and correct use, please read this installation manual thoroughly before installing the air-conditioner unit.

FOR INSTALLER

INSTALLATIONSHANDBUCH

Zum sicheren und ordnungsgemäßen Gebrauch der Klimaanlage das Installationshandbuch gründlich durchlesen.

FÜR INSTALLATEURE

MANUEL D'INSTALLATION

Veillez lire le manuel d'installation en entier avant d'installer ce climatiseur pour éviter tout accident et vous assurer d'une utilisation correcte.

POUR L'INSTALLATEUR

INSTALLATIEHANDLEIDING

Voor een veilig en juist gebruik moet u deze installatiehandleiding grondig doorlezen voordat u de airconditioner installeert.

VOOR DE INSTALLATEUR

MANUAL DE INSTALACIÓN

Para un uso seguro y correcto, lea detalladamente este manual de instalación antes de montar la unidad de aire acondicionado.

PARA EL INSTALADOR

MANUALE DI INSTALLAZIONE

Per un uso sicuro e corretto, leggere attentamente questo manuale di installazione prima di installare il condizionatore d'aria.

PER L'INSTALLATORE

ΕΓΧΕΙΡΙΔΙΟ ΟΔΗΓΙΩΝ ΕΓΚΑΤΑΣΤΑΣΗΣ

Για ασφάλεια και σωστή χρήση, παρακαλείσθε διαβάσετε προσεχτικά αυτό το εγχειρίδιο εγκατάστασης πριν αρχίσετε την εγκατάσταση της μονάδας κλιματισμού.

ΓΙΑ ΑΥΤΟΝ ΠΟΥ ΚΑΝΕΙ ΤΗΝ ΕΓΚΑΤΑΣΤΑΣΗ

MANUAL DE INSTALAÇÃO

Para segurança e utilização correctas, leia atentamente este manual de instalação antes de instalar a unidade de ar condicionado.

PARA O INSTALADOR

MONTAJ ELKİTABI

Emniyetli ve doğru biçimde nasıl kullanılacağını öğrenmek için lütfen klima cihazını monte etmeden önce bu elkitabını dikkatle okuyunuz.

MONTÖR İÇİN

РУКОВОДСТВО ПО УСТАНОВКЕ

Для осторожного и правильного использования прибора необходимо тщательно ознакомиться с данным руководством по установке до выполнения установки кондиционера.

ДЛЯ УСТАНОВИТЕЛЯ

安装说明书

在安装空调机之前，请先通读此安装说明书，以便安全正确地使用。

安装人员适用**English****Deutsch****Français****Nederlands****Español****Italiano****Ελληνικά****Português****Türkçe****Русский****中文**

Contents

1. Safety precautions	2	5. Drainage piping work	5
2. Installation location	2	6. Electrical work	6
3. Installing the indoor unit	3	7. Test run (Fig. 7-1)	7
4. Refrigerant pipe	4		

1. Safety precautions

- ▶ Before installing the unit, make sure you read all the "Safety precautions".
- ▶ Please report to your supply authority or obtain their consent before connecting this equipment to the power supply system.

⚠ Warning:
Describes precautions that must be observed to prevent danger of injury or death to the user.

⚠ Caution:
Describes precautions that must be observed to prevent damage to the unit.

After installation work has been completed, explain the "Safety Precautions," use, and maintenance of the unit to the customer according to the information in the Operation Manual and perform the test run to ensure normal operation. Both the Installation Manual and Operation Manual must be given to the user for keeping. These manuals must be passed on to subsequent users.

- ⚠ Warning:**
- Ask the dealer or an authorized technician to install the air conditioner.
 - Install the unit at a place that can withstand its weight.
 - Use the specified cables for wiring.
 - Use only accessories authorized by Mitsubishi Electric and ask the dealer or an authorized technician to install them.
 - Do not touch the heat exchanger fins.
 - Install the air conditioner according to this Installation Manual.

- ⚠ Caution:**
- Do not use the existing refrigerant piping, when use R410A or R407C refrigerant.
 - Use ester oil, either oil or alkylbenzene (small amount) as the refrigerator oil to coat flares and flange connections, when use R410A or R407C refrigerant.
 - Do not use the air conditioner where food, pets, plants, precision instruments, or artwork are kept.
 - Do not use the air conditioner in special environments.

- ⊘ : Indicates an action that must be avoided.
- ⚠ : Indicates that important instructions must be followed.
- ⚡ : Indicates a part which must be grounded.
- ⚠ : Indicates that caution should be taken with rotating parts.
- ⚡ : Indicates that the main switch must be turned off before servicing.
- ⚠ : Beware of electric shock.
- ⚠ : Beware of hot surface.
- ⚡ ELV: At servicing, please shut down the power supply for both the Indoor and Outdoor Unit.

⚠ Warning:
Carefully read the labels affixed to the main unit.

- Have all electric work done by a licensed electrician according to local regulations.
- If the air conditioner is installed in a small room, measures must be taken to prevent the refrigerant concentration from exceeding the safety limit even if the refrigerant should leak.
- The cut face punched parts may cause injury by cut, etc. The installers are requested to wear protective equipment such as gloves, etc.

- Ground the unit.
- Install an leak circuit breaker, as required.
- Use power line cables of sufficient current carrying capacity and rating.
- Use only a circuit breaker and fuse of the specified capacity.
- Do not touch the switches with wet fingers.
- Do not touch the refrigerant pipes during and immediately after operation.
- Do not operate the air conditioner with the panels and guards removed.
- Do not turn off the power immediately after stopping operation.

2. Installation location

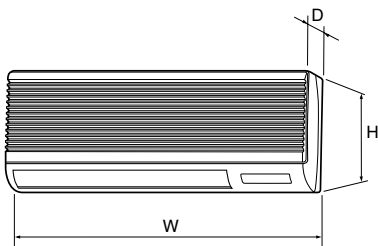

The indoor unit comes with the following parts and accessories:

PART NUMBER	ACCESSORY	QUANTITY	LOCATION OF SETTING
①	Wall-fixing bracket	1	Fix at the back of the unit.
②	Tapping screw 4 × 35	12	Set in packing material.
③	Felt tape	3	
④	Pipe cover	1	
⑤	Band	3	
⑥	Flare nut 3/8 F P50	1	
⑦	Flare nut 5/8 F P50	1	

2.1. Outline dimensions (Fig. 2-1)

Select a proper position allowing the following clearances for installation and maintenance.

Models	W	D	H	(A)	(E)	(F)	(G)	(H)
PKFY-P-VGM	990	235	340	Min. 30	Max. 130	Min. 180	Min. 50	Min. 150

Ⓐ Ceiling Ⓒ Wall Ⓓ Furnishing, etc

⚠ Warning:
Mount the indoor unit on a ceiling strong enough to withstand the weight of the unit.

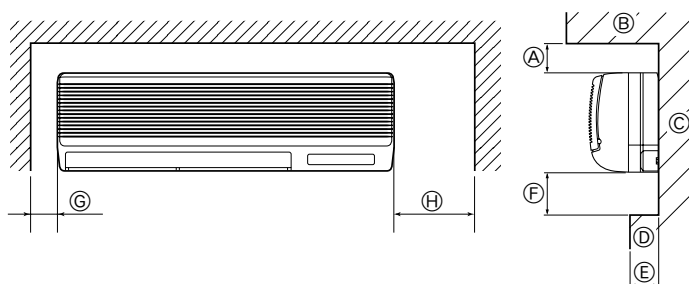

Fig. 2-1

3. Installing the indoor unit

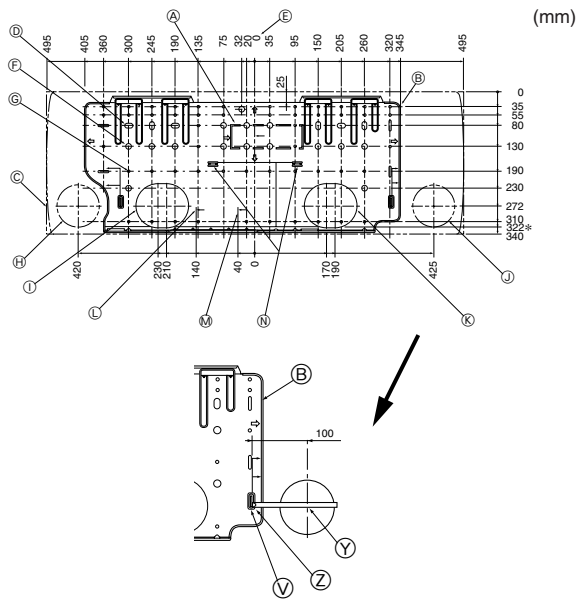

Fig. 3-1

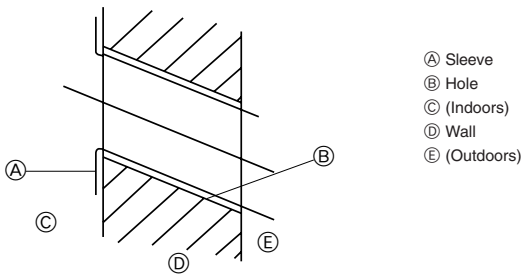

Fig. 3-2

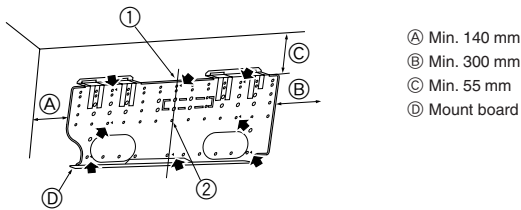

Fig. 3-3

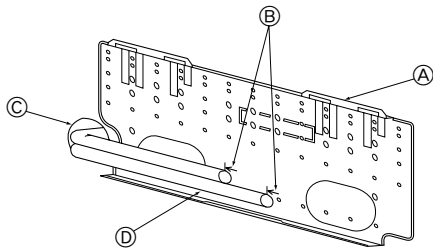

Fig. 3-4

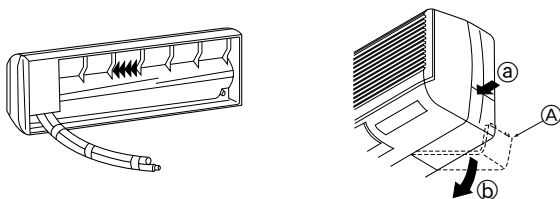

Fig. 3-5

3.1. Installing the wall mounting fixture (Fig. 3-1)

3.1.1. Setting the wall mounting fixture and piping positions

► Using the wall mounting fixture, determine the unit's installation position and the locations of the piping holes to be drilled.

⚠ Warning:

Before drilling a hole in the wall, you must consult the building contractor.

- | | |
|---------------------------------------|---|
| Ⓐ Supporting piece | Ⓜ Gas pipe flare connection position |
| Ⓑ Mount board | Ⓝ Level setting standard |
| Ⓒ Main body | Ⓞ Insert scale. |
| Ⓓ Slot (6-11 × 20) | Ⓟ Hole centre |
| Ⓔ Unit center | Ⓠ Align the scale with the line. |
| Ⓕ Bolt hole (14-φ14) | |
| Ⓖ Tapping hole (49-φ5) | |
| Ⓗ Bottom left pipe slot (φ90) | |
| Ⓛ Bottom left pipe slot knockout hole | |
| | Ⓡ Bottom right pipe slot (φ90) |
| | Ⓢ Bottom right pipe slot knockout hole |
| | Ⓣ Liquid pipe flare connection position |
| | Ⓤ Gas pipe flare connection position |
| | Ⓡ Hole centre |
| | Ⓢ Align the scale with the line. |

3.1.2. Drilling the piping hole (Fig. 3-2)

- Use a core drill to make a hole of 90-100 mm diameter in the wall in the piping direction, at the position shown in the diagram to the left.
- The hole should incline so that the outside opening is lower than the inside opening.
- Insert a sleeve (with a 90 mm diameter and purchased locally) through the hole.

Note:

The purpose of the hole's inclination is to promote drain flow.

3.1.3. Installing the wall mounting fixture (Fig. 3-3)

- Since the indoor unit weighs near 30 kg, selection of the mounting location requires thorough consideration. If the wall does not seem to be strong enough, reinforce it with boards or beams before installation.
- The mounting fixture must be secured at both ends and at the centre, if possible. Never fix it at a single spot or in any nonsymmetrical way. (If possible, secure the fixture at all the positions marked with a bold arrow.)

⚠ Warning:

If possible, secure the fixture at all positions indicated with a bold arrow.

⚠ Caution:

- The unit body must be mounted horizontally.
- Fasten at the holes marked with ▲ as shown by the arrows.
 - ① Fasten a thread to the hole
 - ② The level can be easily obtained by hanging a weight from the string and aligning the string with the mark.

3.2. When embedding pipes into the wall (Fig. 3-4)

- The pipes are on the bottom left.
- When the cooling pipe, drain pipes internal/external connection lines etc are to be embedded into the wall in advance, the extruding pipes etc, may have to be bent and have their length modified to suit the unit.
- Use marking on the mount board as a reference when adjusting the length of the embedded cooling pipe.
- During construction, give the length of the extruding pipes etc some leeway.
 - Ⓐ Mount board
 - Ⓑ Reference marking for flare connection
 - Ⓒ Through hole
 - Ⓓ On-site piping

3.3. Preparing the indoor unit

Rear, right and lower piping (Fig. 3-5)

1. Bind the cooling pipe and drain pipe together.
 - Bind the pipes together with vinyl tape at three or more points. This will facilitate passing the pipes through the wall.
2. Remove the corner box and knock out the knockout holes as necessary.
 - Remove the corner box by pushing in a downward direction Ⓑ, while at the same time, pressing in the upper side part of the corner box Ⓐ.
 - Ⓐ Corner box
 - Ⓑ Under cover

3. Installing the indoor unit

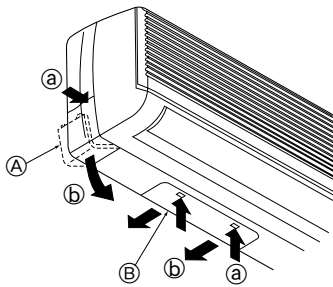

Fig. 3-6

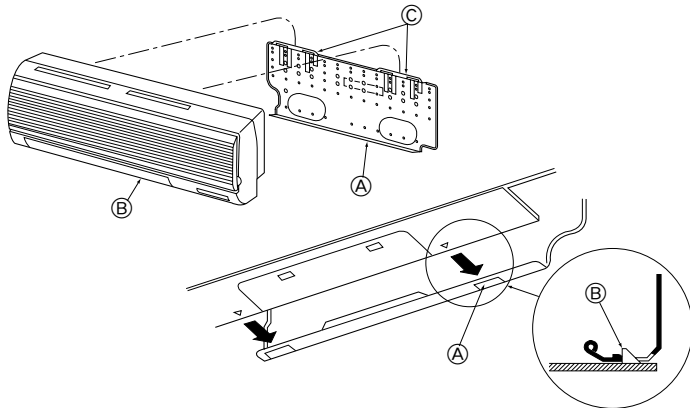

Fig. 3-7

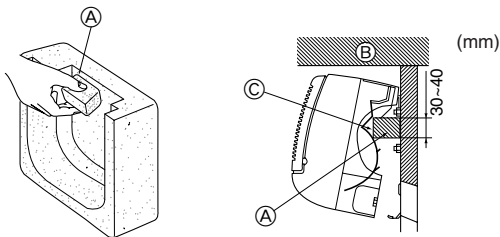

Fig. 3-8

Left and left rear piping (Fig. 3-6)

1. Remove the under cover.
- Remove the under cover by sliding it towards the rear of the unit (B), while at the same time, pressing the two points marked by arrow heads (a).
2. Remove the corner box and knock out the knockout holes as necessary.

3.4. Mounting the indoor unit

1. Affix the mounting plate to the wall.
2. Hang the indoor unit on the two hooks positioned on the upper part of the mounting plate.

Rear, right and lower piping (Fig. 3-7)

3. Affix the indoor unit.
 4. After connecting the pipes, put the corner box back to where it was (follow the removal steps backwards).
- (A) Square hole
 (B) Hooks

Left and left rear piping (Fig. 3-8)

3. Cut out a mounting piece from the packaging material.
 4. Pull the indoor unit up towards yourself as shown in the figure below and slide the mounting piece in to the mounting plate using the mounting piece setting marks as reference.
 5. After connecting the pipes and wiring, put the under cover back to where it was, and remove the mounting piece and affix the indoor unit as shown in the left figure.
 6. Put the corner box back to where it was.
- (A) Mounting piece
 (B) Ceiling
 (C) Rib

4. Refrigerant pipe

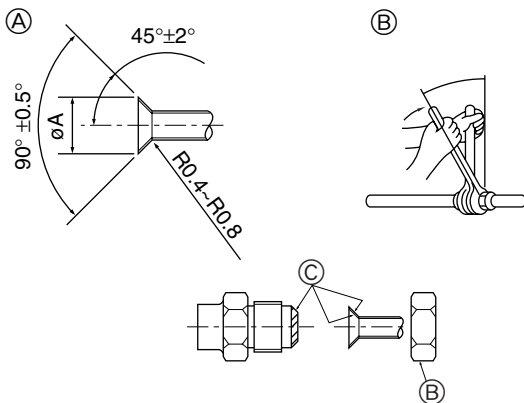

Fig. 4-1

4.1. Connecting pipes (Fig. 4-1)

- When commercially available copper pipes are used, wrap liquid and gas pipes with commercially available insulation materials (heat-resistant to 100 °C or more, thickness of 12 mm or more).
- The indoor parts of the drain pipe should be wrapped with polyethylene foam insulation materials (specific gravity of 0.03, thickness of 9 mm or more).
- Apply thin layer of refrigerant oil to pipe and joint seating surface before tightening flare nut.
- Use two wrenches to tighten piping connections.
- Use refrigerant piping insulation provided to insulate indoor unit connections. Insulate carefully.

(A) Flare cutting dimensions

Copper pipe O.D. (mm)	Flare dimensions øA dimensions (mm)
ø6.35	8.7 - 9.1
ø9.52	12.8 - 13.2
ø12.7	16.2 - 16.6
ø15.88	19.3 - 19.7
ø19.05	22.9 - 23.3

(B) Refrigerant pipe sizes & Flare nut tightening torque

	R407C or R22				R410A				Flare nut O.D.	
	Liquid pipe		Gas pipe		Liquid pipe		Gas pipe		Liquid pipe (mm)	Gas pipe (mm)
	Pipe size (mm)	Tightening torque (N.m)	Pipe size (mm)	Tightening torque (N.m)	Pipe size (mm)	Tightening torque (N.m)	Pipe size (mm)	Tightening torque (N.m)		
P20/25/32/40	ODø6.35 (1/4")	14 - 18	ODø12.7 (1/2")	49 - 61	ODø6.35 (1/4")	14 - 18	ODø12.7 (1/2")	49 - 61	17	26
P50	ODø9.52 (3/8")	34 - 42*	ODø15.88 (5/8")	68 - 82*	ODø6.35 (1/4")	34 - 42	ODø12.7 (1/2")	68 - 82	22	29
P63/80	ODø9.52 (3/8")	34 - 42	ODø15.88 (5/8")	68 - 82	ODø9.52 (3/8")	34 - 42	ODø15.88 (5/8")	68 - 82	22	29
P100/125	ODø9.52 (3/8")	34 - 42	ODø19.05 (3/4")	100 - 120*	ODø9.52 (3/8")	34 - 42	ODø15.88 (5/8")	100 - 120	22	36

* Use the provided flare nut for the following pipes: Liquid pipe of P50, P100, P125, and gas pipe of P50.

(C) Apply refrigerating machine oil over the entire flare seat surface.

4. Refrigerant pipe

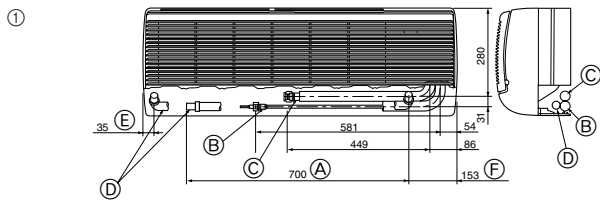

Fig. 4-2

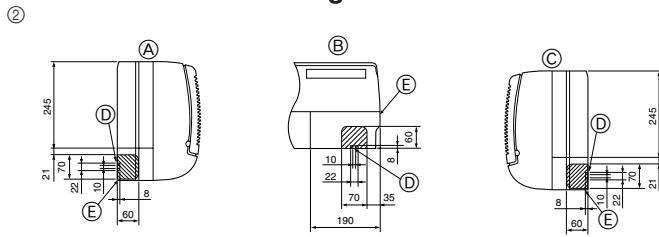

Fig. 4-3

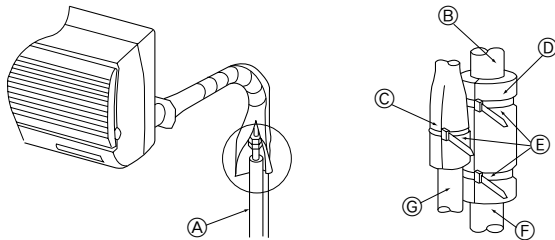

Fig. 4-4

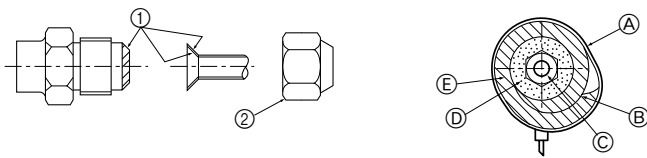

Fig. 4-5

4.2. Positioning refrigerant and drain piping

① Position of refrigerant and drain piping (Fig. 4-2)

- The drain pipe can be cut midway to meet the on-site conditions.
 - A (Total length of flexible hose)
 - B Liquid pipe
 - C Gas pipe
 - D Drain hose
 - E Left-side piping
 - F Right-side piping

② Determine the position of the knockout holes on the unit body. (Fig. 4-3)

► **Cut the knockout holes using a saw blade or an adequate knife.** Take care not to damage other parts of the unit.

- Remove the corner box and drill a knockout hole. If a hole is made without removing the box, the drain hose could be damaged.

- A Left-side piping
- B Lower piping
- C Right-side piping
- D Remote controller cable through hole
- E Corner box

4.3. Refrigerant piping (Fig. 4-4)

Indoor unit

- Remove the flare nut and cap of the indoor unit.
- Make a flare for the liquid pipe and gas pipe and apply refrigerating machine oil (available from your local supplier) to the flare sheet surface.
- Quickly connect the on site cooling pipes to the unit.
- Wrap the pipe cover ③ that is attached to the gas pipe and make sure that the connection joint is not visible.
- Wrap the pipe cover of the unit's liquid pipe and make sure that it covers the insulation material of the on site liquid pipe.
- Use the bands that are provided ④ to tighten both ends (15 – 20mm) of each pipe cover ③.

- A Cooling pipe and insulation (available from local supplier)
- B Unit's gas pipe
- C Unit's liquid pipe
- D Pipe cover ③
- E Bands ④
- F On site gas pipe
- G On site liquid pipe

When using commercially available copper pipes: (Fig. 4-5)

See that stop valve on outdoor unit is fully shut (unit is shipped with valve shut). After all piping connections between indoor and outdoor unit have been completed, vacuum-purge air from system through the service port for the stop valve on the outdoor unit.

- Apply refrigerating machine oil all over the flare sheet.
 - Always use the flare nuts that are attached to the main unit.
- A Band ④
 - B Tightly wrapped
 - C Refrigerant pipe
 - D Refrigerant pipe insulation
 - E Pipe cover ③

- To prevent Refrigerant pipes from gathering moisture, wrap the pipes that are in the unit's pipe storage space with the felt tape provided ⑤.

5. Drainage piping work

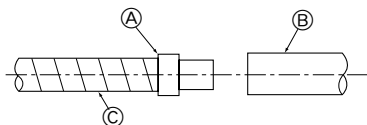

Fig. 5-1

5.1. Drainage piping work (Fig. 5-1)

- Drain pipes should have an inclination of 1/100 or more.
- For extension of the drain pipe, use a soft hose (inner dia. 15 mm) available on the market or hard vinyl chloride pipe (VP-20). Make sure that there is no water leakage from the connections.
- If the drain pipe passes indoors it must be covered with insulating material (foamed polyethylene: specific gravity: 0.03, thickness: 9 mm or more) available on the market.
- Do not put the drain piping directly in a drainage ditch where sulphuric gas may be generated.
- When piping has been completed, check that water flows from the end of the drain pipe.

- A Drain connection socket
- B On site drain pipe (VP-20)
- C Indoor unit's drain hose

⚠ Caution:

The drain pipe should be installed according to this Installation Manual to ensure correct drainage. Thermal insulation of the drain pipes is necessary to prevent condensation. If the drain pipes are not properly installed and insulated, condensation may drip on the ceiling, floor or other possessions.

5. Drainage piping work

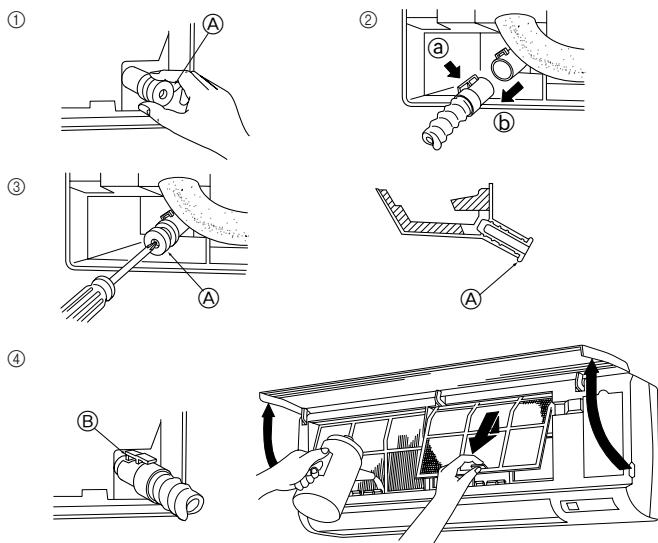

Fig. 5-2

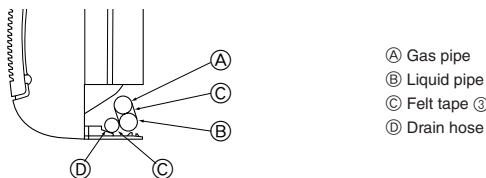

Fig. 5-3

Preparing left and left rear piping (Fig. 5-2)

- ① Remove the drain cap.
 - Remove the drain cap by holding the bit that sticks out at the end of the pipe and pulling.
 - Ⓐ Drain cap
- ② Remove the drain hose.
 - Remove the drain hose by holding on to the base of the hose Ⓐ (shown by arrow) and pulling towards yourself Ⓓ.
- ③ Insert the drain cap.
 - Insert a screwdriver etc into the hole at the end of the pipe and be sure to push to the base of the drain cap.
- ④ Insert the drain hose.
 - Push the drain hose until it is at the base of the drain box connection outlet.
 - Please make sure the drain hose hook is fastened properly over the extruding drain box connection outlet.
 - Ⓔ Hooks

Remove the side panel of the indoor unit on the drain side. Pour water in the drain pan and check that it comes out the drain pipe end. After confirmation, reinstall the side panel.

5.2. Completing the piping (Fig. 5-3)

Using the unit's pipe storage space (for left and left rear piping)

- To prevent cooling pipes from gathering moisture, wrap the pipes that are in the unit's pipe storage space with the felt tape provided ③.
- When wrapping with the felt tape, be sure to double over by no more than half the width of the tape.
- Use a bandage clip etc to fasten the end to the felt tape.

6. Electrical work

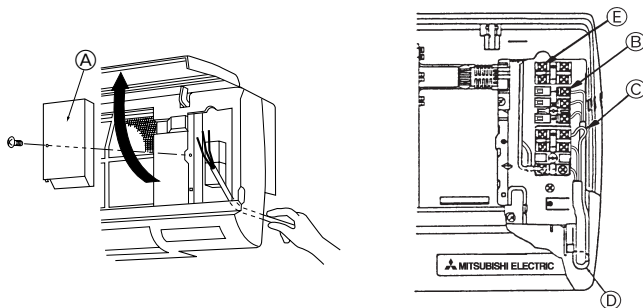

Fig. 6-1

6.1. Indoor unit (Fig. 6-1)

1. Remove the corner box.
2. Install each wire into the unit.
3. Open the front grill, remove 1 tapping screw and remove the terminal block cover.
4. Connect each wire properly to the terminal block.
 - In consideration of future servicing, please leave some leeway for the wiring length.
5. Put all the parts back the way they were.
6. Use a clamp from the bottom of the electric parts box to fasten each wire.
 - Ⓐ Terminal block cover
 - Ⓑ Terminal block for transmission cable
Non polarized M1, M2
 - Ⓒ Terminal block for power supply
Polarized L, N, ⊕
 - Ⓓ Clamp to fasten wires
 - Ⓔ MA remote controller terminals
Non polarized 1, 2

Power supply wiring

- Power supply codes of appliance shall not be lighter than design 245 IEC 53 or 227 IEC 53.
- Install an earth longer and thicker than other cables.

A means for the disconnection of the supply with an isolation switch, or similar device, in all active conductors shall be incorporated in the fixed wiring.

6.2. Connecting remote controller, indoor and outdoor transmission cables (Fig. 6-2)

- Connect indoor unit TB5 and outdoor unit TB3. (Non-polarized 2-wire)
The "S" on indoor unit TB5 is a shielding wire connection. For specifications about the connecting cables, refer to the outdoor unit installation manual.
 - Install a remote controller following the manual supplied with the remote controller.
 - Connect the remote controller's transmission cable within 10 m using a 0.75 mm² core cable. If the distance is more than 10 m, use a 1.25 mm² junction cable.
- ① MA Remote controller
 - Connect the "1" and "2" on indoor unit TB15 to a MA remote controller. (Non-polarized 2-wire)
 - DC 9 to 13 V between 1 and 2 (MA remote controller)
 - ② M-NET Remote controller
 - Connect the "M1" and "M2" on indoor unit TB5 to a M-NET remote controller. (Non-polarized 2-wire)
 - DC 24 to 30 V between M1 and M2 (M-NET remote controller)
 - Ⓐ Terminal block for indoor transmission cable
 - Ⓑ Terminal block for outdoor transmission cable
 - Ⓒ Remote controller

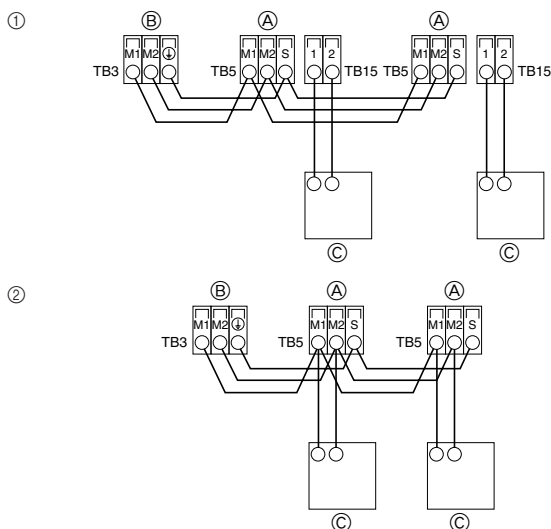

Fig. 6-2

6. Electrical work

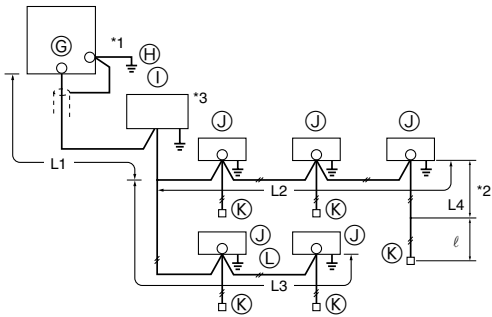

Fig. 6-3

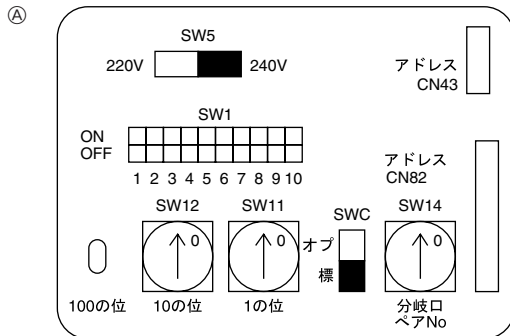

Fig. 6-4

Constraints on transmission cable (Fig. 6-3)

Longest wiring length ($L1+L2+L4$ or $L1+L3$ or $L2+L3+L4$): less than 200 m
Length between indoor unit and remote controller (l): within 10 m

- Ⓒ Outdoor unit
- Ⓓ Earth
- Ⓔ BC controller
- Ⓕ Indoor unit
- Ⓖ M-NET Remote controller
- Ⓗ Non-polarized 2-wire

Note:

- *1 Put the transmission cable earth via the outdoor unit's earth terminal (Ⓓ) to the ground.
- *2 If the remote controller cable exceeds 10 m, use a 1.25 mm² diameter cable over the exceeded portion, and add that exceeded portion to within 200 m.
- *3 The BC controller is required only for simultaneous cooling and heating series R2.

6.3. Setting addresses (Fig. 6-4)

(Be sure to operate with the main power turned OFF.)

- There are two types of rotary switch setting available: setting addresses 1 to 9 and over 10, and setting branch numbers.

Note:

- Please set the switch SW5 according to the power supply voltage.
- Set SW5 to 240 V side when the power supply is 230 and 240 volts.
- When the power supply is 220 volts, set SW5 to 220 V side.

Ⓐ Address board

6.4. Types of control cables

1. Wiring transmission cables: Shielding wire CVVS or CPEVS

- Cable diameter: More than 1.25 mm²

2. M-NET Remote control cables

Kind of remote control cable	Shielding wire MVVS
Cable diameter	More than 0.5 to 1.25 mm ²
Remarks	When 10 m is exceeded, use cable with the same specifications as transmission line wiring.

3. MA Remote control cables

Kind of remote control cable	2-core cable (unshielded)
Cable diameter	0.3 to 1.25 mm ²

7. Test run (Fig. 7-1)

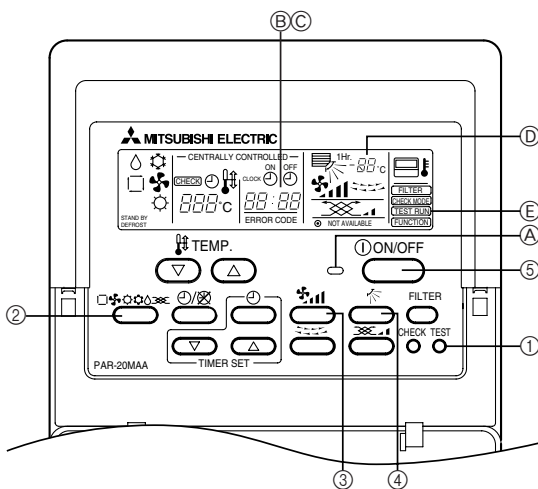

Fig. 7-1

- ① Press [TEST RUN] button twice → displaying [TEST RUN] on the screen.
- ② Press [Selecting operation] button. → Check that wind is blowing out.
- ③ Press [Fan speed adjustment] button. → Check that the wind speed is changed.
- ④ Press [Up/down airflow selection] button to change wind direction.
- ⑤ Press [ON/OFF] button to clear test run. → Test run stops.

- Ⓐ Lighting in operation
- Ⓑ Displaying inspection code
- Ⓒ Displaying remaining test run time
- Ⓓ Displaying indoor unit's liquid pipe temperature
- Ⓔ Displaying test run

Note:

- The 2-hour-set timer is activated to automatically stop test run after two hours.
- The remote controller displays the temperature of the indoor unit's liquid pipe on the temperature display section during test run.

This product is designed and intended for use in the residential,
commercial and light-industrial environment.

The product at hand is based on the following EU regulations:

- Low Voltage Directive 73/23/ EEC
- Electromagnetic Compatibility Directive 89/336/ EEC

Please be sure to put the contact address/telephone number on
this manual before handing it to the customer.