



Air-Conditioners For Building Application

2004

TECHNICAL & SERVICE MANUAL

Series PEFY Ceiling Concealed

<Indoor unit>

Models **PEFY-P20VML-E**
PEFY-P25VML-E
PEFY-P32VML-E

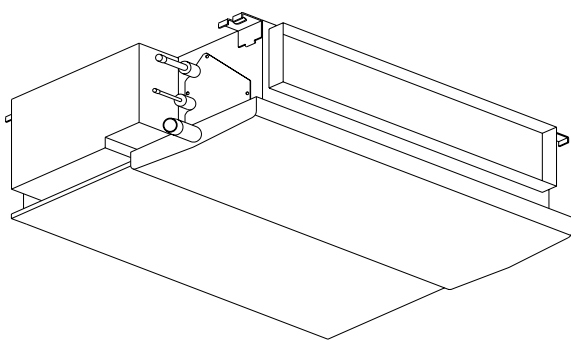

INDOOR UNIT

CONTENTS

| | |
|-------------------------------------|----|
| SAFETY PRECAUTIONS | 1 |
| 1. FEATURES | 3 |
| 2. PART NAMES AND FUNCTIONS | 4 |
| 3. SPECIFICATION | 6 |
| 4. OUTLINES AND DIMENSIONS | 8 |
| 5. WIRING DIAGRAM | 9 |
| 6. REFRIGERANT SYSTEM DIAGRAM | 10 |
| 7. TROUBLE SHOOTING | 11 |
| 8. DISASSEMBLY PROCEDURE | 14 |

CITY MULTI

For use with the R410A & R407C & R22

SAFETY PRECAUTIONS

1. Before installation and electric work

- ▶ **Before installing the unit, make sure you read all the “Safety precautions”.**
- ▶ **The “Safety precautions” provide very important points regarding safety. Make sure you follow them.**
- ▶ **This equipment may cause the adverse effect on the same supply system.**
- ▶ **Please report to or take consent by the supply authority before connection to the system.**

Symbols used in the text

Warning:

Describes precautions that should be observed to prevent danger of injury or death to the user.

Caution:

Describes precautions that should be observed to prevent damage to the unit.

Symbols used in the illustrations



: Indicates an action that must be avoided.



: Indicates that important instructions must be followed.



: Indicates a part which must be grounded.



: Indicates that caution should be taken with rotating parts. (This symbol is displayed on the main unit label.) <Color: Yellow>



: Beware of electric shock (This symbol is displayed on the main unit label.) <Color: Yellow>

Warning:

Carefully read the labels affixed to the main unit.

Warning:

- **Ask the dealer or an authorized technician to install the air conditioner.**
 - Improper installation by the user may result in water leakage, electric shock, or fire.
- **Install the air unit at a place that can withstand its weight.**
 - Inadequate strength may cause the unit to fall down, resulting in injuries.
- **Use the specified cables for wiring. Make the connections securely so that the outside force of the cable is not applied to the terminals.**
 - Inadequate connection and fastening may generate heat and cause a fire.
- **Prepare for typhoons and other strong winds and earthquakes and install the unit at the specified place.**
 - Improper installation may cause the unit to topple and result in injury.
- **Always use an air cleaner, humidifier, electric heater, and other accessories specified by Mitsubishi Electric.**
 - Ask an authorized technician to install the accessories. Improper installation by the user may result in water leakage, electric shock, or fire.

- **Never repair the unit. If the air conditioner must be repaired, consult the dealer.**
 - If the unit is repaired improperly, water leakage, electric shock, or fire may result.
- **Do not touch the heat exchanger fins.**
 - Improper handling may result in injury.
- **If refrigerant gas leaks during installation work, ventilate the room.**
 - If the refrigerant gas comes into contact with a flame, poisonous gases will be released.
- **Install the air conditioner according to this Installation Manual.**
 - If the unit is installed improperly, water leakage, electric shock, or fire may result.
- **Have all electric work done by a licensed electrician according to “Electric Facility Engineering Standard” and “Interior Wire Regulations” and the instructions given in this manual and always use a special circuit.**
 - If the power source capacity is inadequate or electric work is performed improperly, electric shock and fire may result.
- **Keep the electric parts away from water (washing water etc.).**
 - It might result in electric shock, catching fire or smoke.
- **Securely install the cover of control box and the panel.**
 - If the cover and panel are not installed properly, dust or water may enter the outdoor unit and fire or electric shock may result.
- **When installing and moving the air conditioner to another site, do not charge the it with a refrigerant different from the refrigerant specified on the unit.**
 - If a different refrigerant or air is mixed with the original refrigerant, the refrigerant cycle may malfunction and the unit may be damaged.
- **If the air conditioner is installed in a small room, measures must be taken to prevent the refrigerant concentration from exceeding the safety limit even if the refrigerant should leak.**
 - Consult the dealer regarding the appropriate measures to prevent the safety limit from being exceeded. Should the refrigerant leak and cause the safety limit to be exceeded, hazards due to lack of oxygen in the room could result.
- **When moving and reinstalling the air conditioner, consult the dealer or an authorized technician.**
 - If the air conditioner is installed improperly, water leakage, electric shock, or fire may result.
- **After completing installation work, make sure that refrigerant gas is not leaking.**
 - If the refrigerant gas leaks and is exposed to a fan heater, stove, oven, or other heat source, it may generate noxious gases.
- **Do not reconstruct or change the settings of the protection devices.**
 - If the pressure switch, thermal switch, or other protection device is shorted and operated forcibly, or parts other than those specified by Mitsubishi Electric are used, fire or explosion may result.
- **To dispose of this product, consult your dealer.**
- **Do not use a leak detection additive.**

2. Precautions for devices that use R410A or R407C refrigerant

Caution:

- **Do not use the existing refrigerant piping.**
 - The old refrigerant and refrigerator oil in the existing piping contains a large amount of chlorine which may cause the refrigerator oil of the new unit to deteriorate.
- **Use refrigerant piping made of C1220 (Cu-DHP) phosphorus deoxidized copper as specified in the *JIS H3300 "Copper and copper alloy seamless pipes and tubes". In addition, be sure that the inner and outer surfaces of the pipes are clean and free of hazardous sulphur, oxides, dust/dirt, shaving particles, oils, moisture, or any other contaminant.**
 - Contaminants on the inside of the refrigerant piping may cause the refrigerant residual oil to deteriorate.

*JIS: Japanese Industrial Standard
- **Store the piping to be used during installation indoors and keep both ends of the piping sealed until just before brazing. (Store elbows and other joints in a plastic bag.)**
 - If dust, dirt, or water enters the refrigerant cycle, deterioration of the oil and compressor trouble may result.
- **Use ester oil, ether oil or alkylbenzene (small amount) as the refrigerator oil to coat flares and flange connections.**
 - The refrigerator oil will degrade if it is mixed with a large amount of mineral oil.
- **Use liquid refrigerant to fill the system.**
 - If gas refrigerant is used to seal the system, the composition of the refrigerant in the cylinder will change and performance may drop.
- **Do not use a refrigerant other than R410A or R407C.**
 - If another refrigerant (R22, etc.) is used, the chlorine in the refrigerant may cause the refrigerator oil to deteriorate.
- **Use a vacuum pump with a reverse flow check valve..**
 - The vacuum pump oil may flow back into the refrigerant cycle and cause the refrigerator oil to deteriorate.
- **Do not use the following tools that are used with conventional refrigerants.
(Gauge manifold, charge hose, gas leak detector, reverse flow check valve, refrigerant charge base, vacuum gauge, refrigerant recovery equipment)**
 - If the conventional refrigerant and refrigerator oil are mixed in the R410A or R407C, the refrigerant may deteriorate.
 - If water is mixed in the R410A or R407C, the refrigerator oil may deteriorate.
 - Since R410A or R407C does not contain any chlorine, gas leak detectors for conventional refrigerants will not react to it.
- **Do not use a charging cylinder.**
 - Using a charging cylinder may cause the refrigerant to deteriorate.
- **Be especially careful when managing the tools.**
 - If dust, dirt, or water gets in the refrigerant cycle, the refrigerant may deteriorate.

Series PEFY Ceiling Concealed

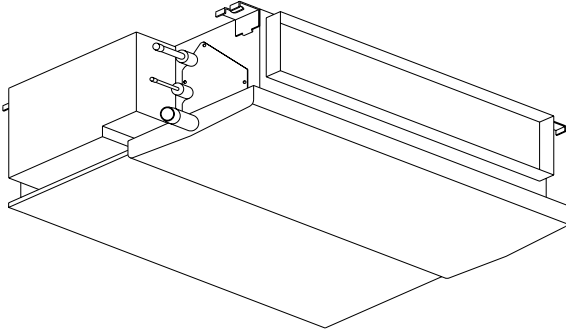

Indoor unit

| Models | Cooling capacity/Heating capacity |
|---------------|-----------------------------------|
| | kW |
| PEFY-P20VML-E | 2.2 / 2.5 |
| PEFY-P25VML-E | 2.8 / 3.2 |
| PEFY-P32VML-E | 3.6 / 4.0 |

2

PART NAMES AND FUNCTIONS

● Indoor (Main) Unit

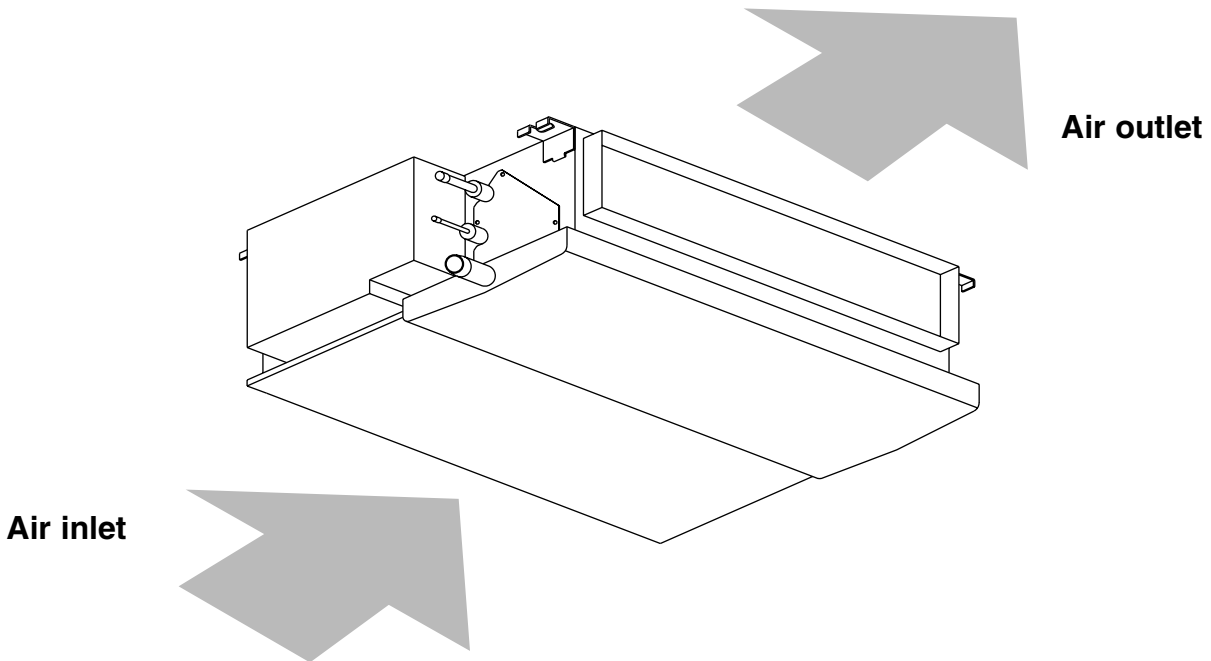

● Remote controller

[PAR-20MAA]

- Once the controls are set, the same operation mode can be repeated by simply pressing the ON/OFF button.

[Operation buttons]

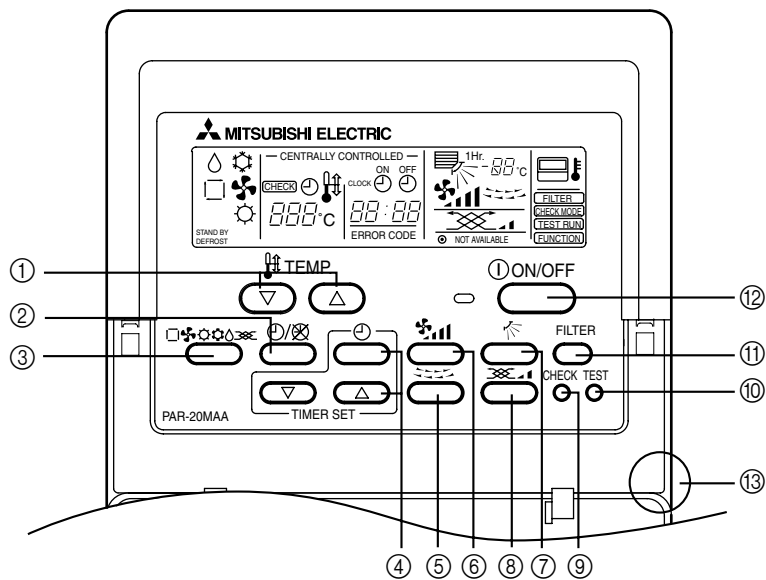

- | | |
|--|---|
| ① [Room temperature adjustment] Button | ⑦ [Up/down airflow direction] Button |
| ② [Timer/continuous] Button | ⑧ [Ventilation] Button |
| ③ [Selecting operation] Button | ⑨ [Checking/built-in] Button |
| ④ [Time selection] Button | ⑩ [Test run] Button |
| [Time-setting] Button | ⑪ [Filter] Button |
| ⑤ [Louver] Button | ⑫ [ON/OFF] Button |
| ⑥ [Fan speed adjustment] Button | ⑬ Position of built-in room temperature |

- Never expose the remote controller to direct sunlight. Doing so can result in the erroneous measurement of room temperature.
- Never place any obstacle around the lower right-hand section of the remote controller. Doing so can result in the erroneous measurement of room temperature.

[Display]

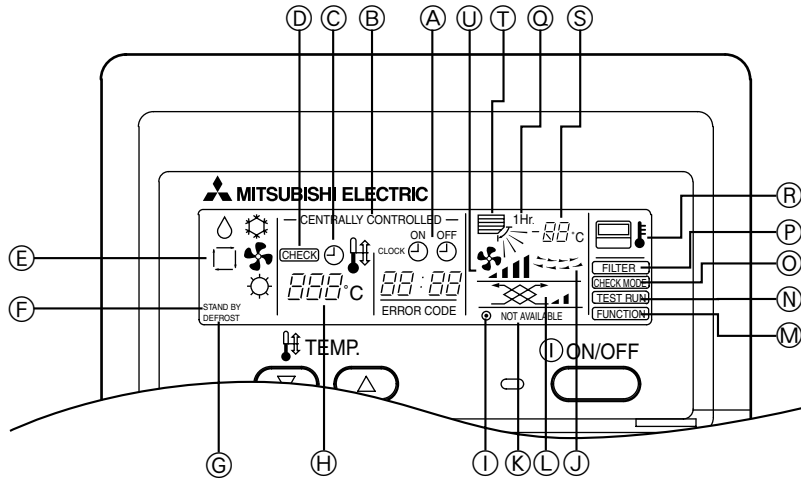

- (A) Current time/Timer
- (B) Centralized control
- (C) Timer ON
- (D) Abnormality occurs
- (E) Operation mode: COOL, DRY, AUTO, FAN, HEAT
- (F) Preparing for Heating mode
- (G) Defrost mode
- (H) Set temperature
- (I) Power ON
- (J) Louver
- (K) Not available function
- (L) Ventilation
- (M) Function setting mode
- (N) Test run mode
- (O) Error check mode
- (P) Filter sign
- (Q) Set effective for 1 hr.
- (R) Sensor position
- (S) Room temperature
- (T) Airflow
- (U) Fan speed

3-1. Specification

| | | | PEFY-P20VML-E | PEFY-P25VML-E | PEFY-P32VML-E |
|-----------------------------|--------------------------|---------------------|--|---------------|---------------|
| Power source | | | ~220-240V 50Hz / 60Hz | | |
| Cooling capacity ※ 1 | kW | | 2.2 | 2.8 | 3.6 |
| Heating capacity ※ 1 | kW | | 2.5 | 3.2 | 4.0 |
| Power consumption (50/60Hz) | Cooling | kW | 0.05/0.06 | | 0.07/0.09 |
| | Heating | kW | 0.05/0.06 | | 0.07/0.09 |
| Current | Cooling | A | 0.24/0.28 | | 0.32/0.42 |
| | Heating | A | 0.24/0.28 | | 0.32/0.42 |
| External finish | | | Galvanized steel plate | | |
| Dimension | Height | mm | 225 | | |
| | Width | mm | 720 | | |
| | Depth | mm | 550 | | |
| Net weight | kg | 18 | | | |
| Heat exchanger | | | Cross fin (Aluminum plate fin and copper tube) | | |
| Fan | Type | | Sirocco fan× 1 | | |
| | Airflow rate (Lo-Mid-Hi) | m ³ /min | 4.8-5.8-7.9 | | 4.8-5.8-9.5 |
| | External static pressure | Pa | 5 | | |
| Motor | Type | | Single phase induction motor | | |
| | Output | kW | 0.023 | | 0.032 |
| Air filter | | | PP Honeycomb fabric (washable) | | |
| Refrigerant pipe dimension | Gas (Brazing) | mm | ø 12.7 | | |
| | Liquid (Brazing) | mm | ø 6.35 | | |
| Drain pipe dimension | | | R1 (External thread) | | |
| Noise level (Lo-Mid-Hi) | dB(A) | | 25-29-36 | | 25-29-40 |

Note: ※ 1 Cooling/Heating capacity indicates the maximum value at operation under the following condition.
Cooling : Indoor 27°CDB/19°CWB, Outdoor 35°CDB (WR2: water 30°C)
Heating : Indoor 20°CDB, Outdoor 7°CDB/6°CWB (WR2: water 20°C)

3-2. Electrical parts specifications

| Model Parts name | Symbol | PEFY-P20VML-E | PEFY-P25VML-E | PEFY-P32VML-E |
|--------------------------------------|-------------|--|---------------|--------------------------------|
| Transformer | T | (Primary) 50/60Hz 220-240V (Secondary) (23.5V 0.9A) | | |
| Room temperature thermistor | TH21 | Resistance 0°C/15kΩ, 10°C/9.6kΩ, 20°C/6.3kΩ, 25°C/5.4kΩ, 30°C/4.3kΩ, 40°C/3.0kΩ | | |
| Liquid pipe thermistor | TH22 | Resistance 0°C/15kΩ, 10°C/9.6kΩ, 20°C/6.3kΩ, 25°C/5.4kΩ, 30°C/4.3kΩ, 40°C/3.0kΩ | | |
| Gas pipe thermistor | TH23 | Resistance 0°C/15kΩ, 10°C/9.6kΩ, 20°C/6.3kΩ, 25°C/5.4kΩ, 30°C/4.3kΩ, 40°C/3.0kΩ | | |
| Fuse (Indoor controller board) | FUSE | 250V 6.3A | | |
| Fan motor (with Inner-thermostat) | MF1,2 | 4-pole Output 23W CRC4417BB | | 4-pole Output 32W CRC4418BB |
| Inner-thermostat (Fan motor) | | OFF 135°C±5°C ON 95°C±15°C | | |
| Fan motor capacitor | C1 | 1.5μFX440V | | 2.0μFX440V |
| Linear expansion valve | LEV | DC12V Stepping motor drive port dimension ø3.2 (0~1800pulse <at R410A outdoor unit>, 0~2000pulse <at the other outdoor unit>) | | |
| Power supply terminal bed | TB2 | (L,N,⊕) 330V 30A | | |
| Transmission terminal bed | TB5 TB15 | (1,2),(M1,M2,S) 300V 10A | | |

PEFY-P20.25.32VML-E

Unit : mm

- Note 1. Use M10 screw for the lifting bolt (field supply).
 2. Keep the service space for the maintenance from the bottom when the heat exchanger is cleaned.
 3. The direction of air intake can be changed from the bottom to the rear by attaching the bottom plate to the air intake side.
 4. Drain Pan is changeable from right and left.
 5. The dimension is changed, in case the optional long-life filter is attached.
 Rear Air-Intake spec. : Depth is increased by 30mm (*1)
 Bottom Air-Intake spec. : Height is increased by 30mm (*2)

- Refrigerant piping brazing connection (gas ø12.7 copper tube) : LP ①
 Refrigerant piping brazing connection (liquid ø6.35 copper tube) : HP ②
 Drain piping connection R1 (External thread) ③

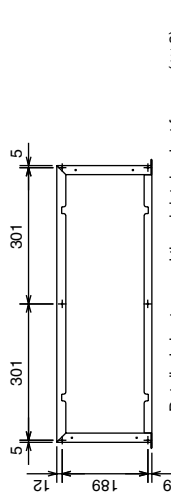
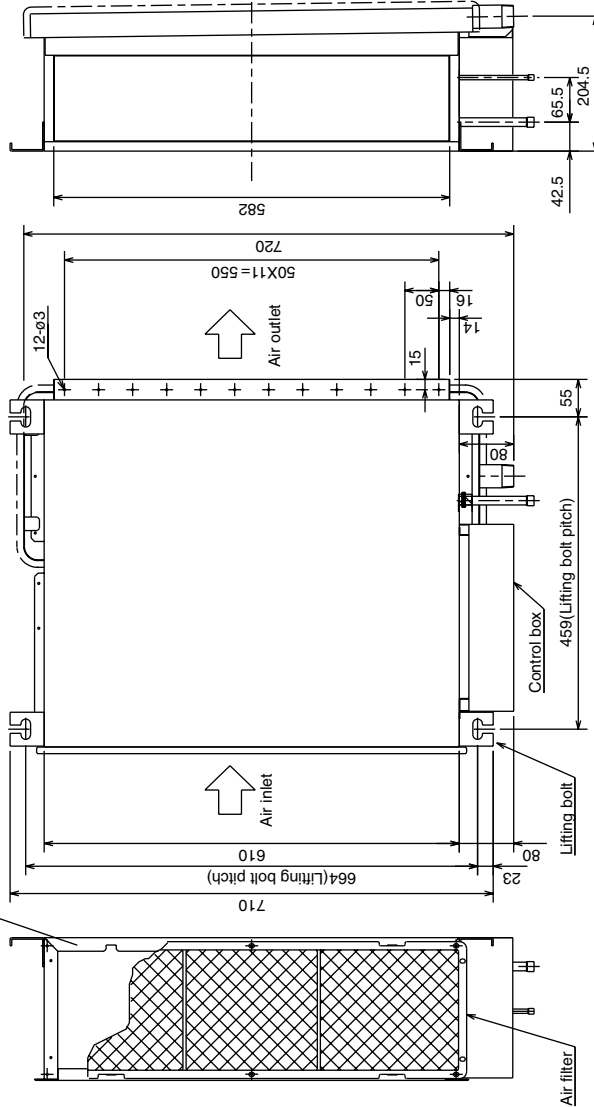

Detailed chart around the air intake duct frange (*3)
 (Duct and frange should be supplied in the field)

Required space for service and maintenance

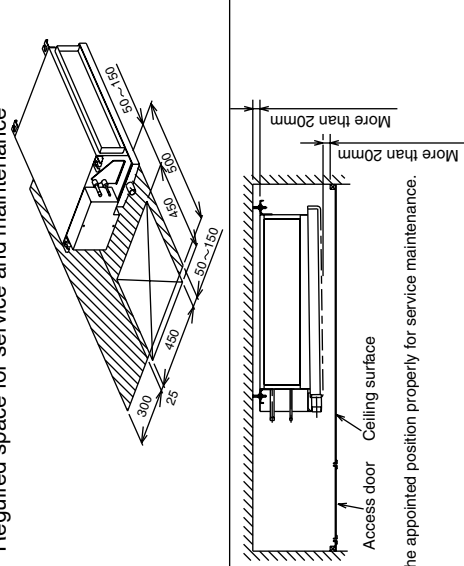

Make the access door at the appointed position properly for service maintenance.

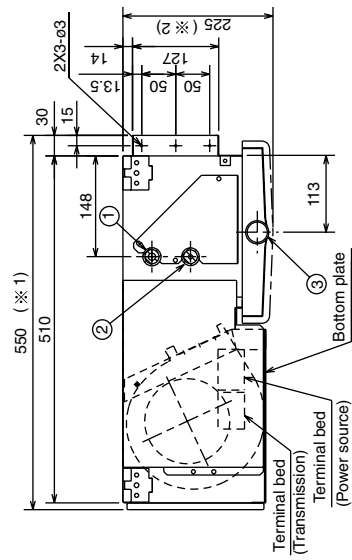

PEFY-P20-25-32VML-E

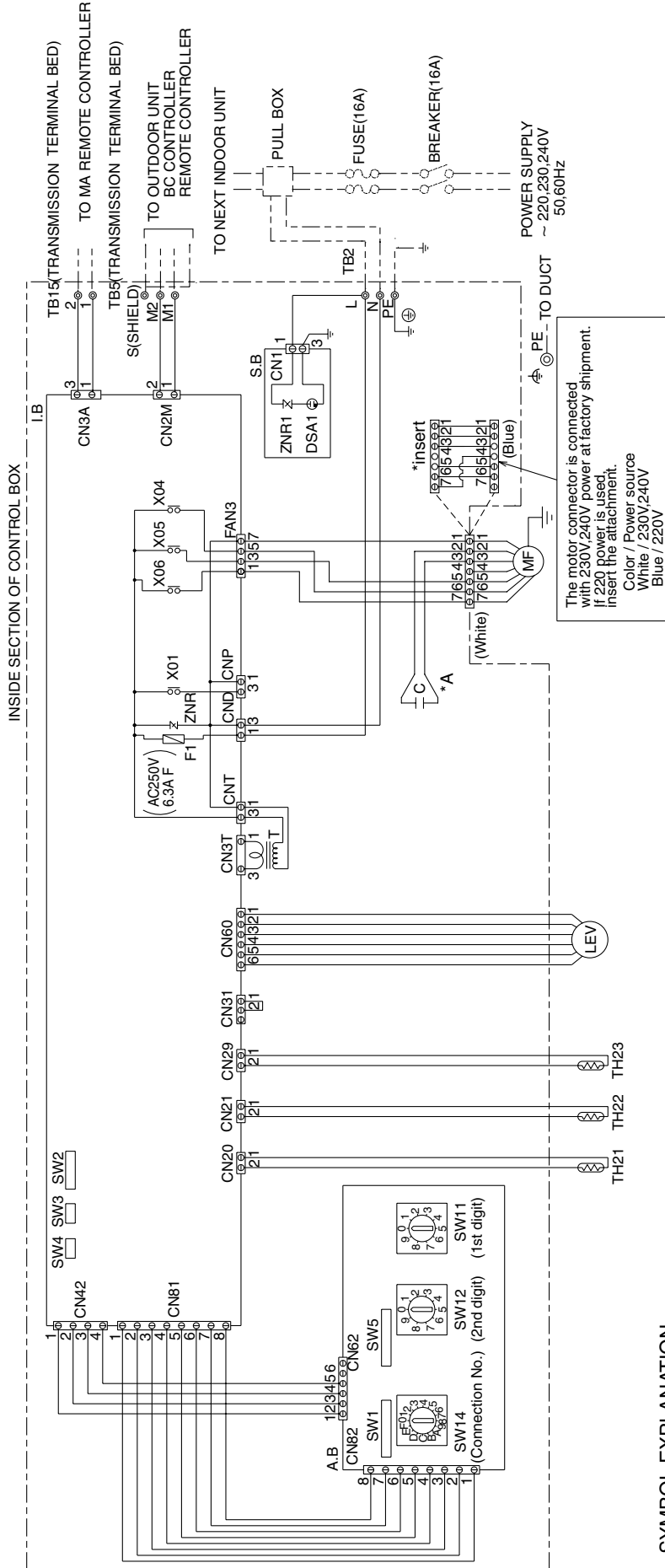

NOTE: 1. The wirings to TB2, TB5 shown in dotted line are field work.
 2. Mark ⊕ indicates terminal bed, ⊕ connector, ⊕ board insertion connector or fastening connector of control board.

SYMBOL EXPLANATION

| SYMBOL | NAME | SYMBOL | NAME |
|---------|--------------------------------|-----------|--|
| MF | Fan motor | TH21 | Thermistor (inlet temp. detection) |
| C | *A Capacitor (for MF) | TH22 | Thermistor (piping temp. detection/liquid) |
| I.B | Indoor controller board | TH23 | Thermistor (piping temp. detection/gas) |
| A.B | Address board | SW11(A,B) | Switch (1st digit address set) |
| TB2 | Power source terminal bed | SW12(A,B) | Switch (2nd digit address set) |
| TB5 | Transmission terminal bed | SW14(A,B) | Switch (connection No. set) |
| TB15 | Transmission terminal bed | SW1(A,B) | Switch (for mode selection) |
| F1 | Fuse AC250V 6.3A F | SW2(L,B) | Switch (for capacity code) |
| T | Transformer | SW3(L,B) | Switch (for mode selection) |
| LEV | Electronic linear expan. valve | SW4(L,B) | Switch (for model selection) |
| S.B | Surge absorber board | SW5(A,B) | Switch (for voltage selection) |
| X04-X06 | Aux. relay | | |

*A Capacitor
 MODELS 20/25 1.5μF
 MODEL 32 2.0μF

6

REFRIGERANT SYSTEM DIAGRAM

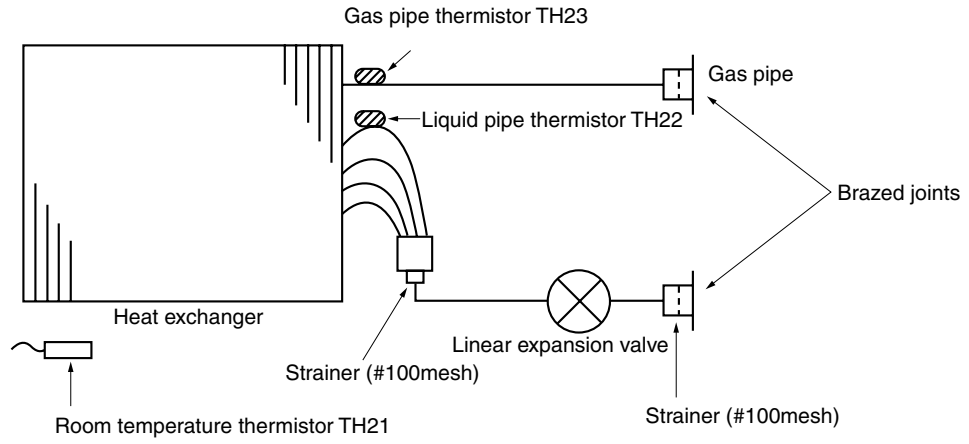

| Item | Capacity | PEFY-P20,25,32VML-E |
|-------------|----------|---------------------|
| Gas pipe | | ø12.7<1/2> |
| Liquid pipe | | ø6.35<1/4> |

7-1. How to check the parts

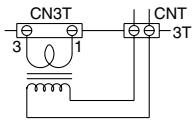
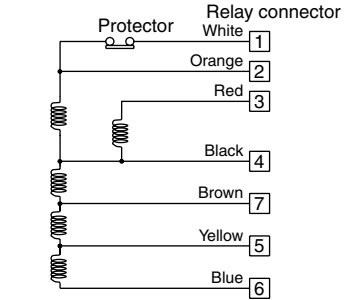
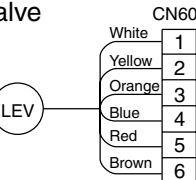
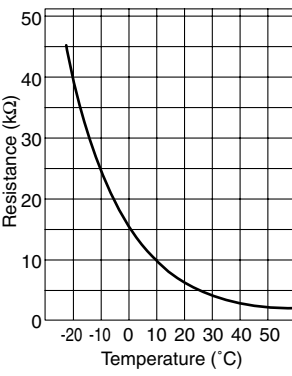
| Parts name | Check points | | | | | | | | | | | | | | | | | | | | |
|--|---|-----------------------|-----------------------------------|---------------|-------------|---------------|---------|---------------|----------------------|-------------------------|-----------------------|-----------------------|---------------|-----------|-------|--------------|-------|-------|------------|-------|-------|
| Room temperature thermistor (TH21) Liquid pipe thermistor (TH22) Gas pipe thermistor (TH23) | Disconnect the connector, then measure the resistance using a tester. (Surrounding temperature 10°C~30°C) <table border="1" data-bbox="379 398 887 472"> <thead> <tr> <th>Normal</th> <th>Abnormal</th> </tr> </thead> <tbody> <tr> <td>4.3kΩ~9.6kΩ</td> <td>Open or short</td> </tr> </tbody> </table> (Refer to the thermistor characteristic graph) | | Normal | Abnormal | 4.3kΩ~9.6kΩ | Open or short | | | | | | | | | | | | | | | |
| Normal | Abnormal | | | | | | | | | | | | | | | | | | | | |
| 4.3kΩ~9.6kΩ | Open or short | | | | | | | | | | | | | | | | | | | | |
| Trans  | Disconnect the connector and measure the resistance using a tester. <table border="1" data-bbox="379 533 1098 645"> <thead> <tr> <th></th> <th>Normal</th> <th>Abnormal</th> </tr> </thead> <tbody> <tr> <td>CNT(1)-(3)</td> <td>App.15Ω</td> <td rowspan="2">Open or short</td> </tr> <tr> <td>CN3T(1)-(3)</td> <td>App.4Ω</td> </tr> </tbody> </table> | | | Normal | Abnormal | CNT(1)-(3) | App.15Ω | Open or short | CN3T(1)-(3) | App.4Ω | | | | | | | | | | | |
| | Normal | Abnormal | | | | | | | | | | | | | | | | | | | |
| CNT(1)-(3) | App.15Ω | Open or short | | | | | | | | | | | | | | | | | | | |
| CN3T(1)-(3) | App.4Ω | | | | | | | | | | | | | | | | | | | | |
| Fan motor PEFY-P20·25·32  | Measure the resistance between the terminals using a tester. (at 20°C) <table border="1" data-bbox="544 703 1458 898"> <thead> <tr> <th rowspan="2">Motor terminal or Relay connector</th> <th colspan="2">Normal</th> <th rowspan="2">Abnormal</th> </tr> <tr> <th>P20·25</th> <th>P32</th> </tr> </thead> <tbody> <tr> <td>White-Black</td> <td>261 Ω</td> <td>232 Ω</td> <td rowspan="5">Open or short</td> </tr> <tr> <td>White-Brown</td> <td>294 Ω</td> <td>259 Ω</td> </tr> <tr> <td>White-Yellow</td> <td>389 Ω</td> <td>450 Ω</td> </tr> <tr> <td>White-Blue</td> <td>475 Ω</td> <td>536 Ω</td> </tr> </tbody> </table> | | Motor terminal or Relay connector | Normal | | Abnormal | P20·25 | P32 | White-Black | 261 Ω | 232 Ω | Open or short | White-Brown | 294 Ω | 259 Ω | White-Yellow | 389 Ω | 450 Ω | White-Blue | 475 Ω | 536 Ω |
| Motor terminal or Relay connector | Normal | | | Abnormal | | | | | | | | | | | | | | | | | |
| | P20·25 | P32 | | | | | | | | | | | | | | | | | | | |
| White-Black | 261 Ω | 232 Ω | Open or short | | | | | | | | | | | | | | | | | | |
| White-Brown | 294 Ω | 259 Ω | | | | | | | | | | | | | | | | | | | |
| White-Yellow | 389 Ω | 450 Ω | | | | | | | | | | | | | | | | | | | |
| White-Blue | 475 Ω | 536 Ω | | | | | | | | | | | | | | | | | | | |
| Linear expansion valve  | Disconnect the connector then measure the resistance valve using a tester. <table border="1" data-bbox="379 1070 1225 1227"> <thead> <tr> <th colspan="4">Normal</th> <th>Abnormal</th> </tr> </thead> <tbody> <tr> <td>(1)-(5) White-Red</td> <td>(2)-(6) Yellow-Brown</td> <td>(3)-(5) Orange-Red</td> <td>(4)-(6) Blue-Brown</td> <td rowspan="2">Open or short</td> </tr> <tr> <td colspan="4" style="text-align: center;">150Ω ±10%</td> </tr> </tbody> </table> | | | Normal | | | | Abnormal | (1)-(5) White-Red | (2)-(6) Yellow-Brown | (3)-(5) Orange-Red | (4)-(6) Blue-Brown | Open or short | 150Ω ±10% | | | | | | | |
| Normal | | | | Abnormal | | | | | | | | | | | | | | | | | |
| (1)-(5) White-Red | (2)-(6) Yellow-Brown | (3)-(5) Orange-Red | (4)-(6) Blue-Brown | Open or short | | | | | | | | | | | | | | | | | |
| 150Ω ±10% | | | | | | | | | | | | | | | | | | | | | |
| <p><Thermistor characteristic graph> Room temperature thermistor(TH21) Liquid pipe thermistor(TH22) Gas pipe temperature thermistor(TH23) Drain sensor(DS)</p> <p>Thermistor $R_0=15k\Omega \pm 3\%$ Fixed number of $B=3480k\Omega \pm 2\%$ $R_t=15\exp \left\{ 3480 \left(\frac{1}{273+t} - \frac{1}{273} \right) \right\}$</p> <p>0°C 15kΩ 10°C 9.6kΩ 20°C 6.3kΩ 25°C 5.2kΩ 30°C 4.3kΩ 40°C 3.0kΩ</p>  | | | | | | | | | | | | | | | | | | | | | |

7-2. Setting of address switch

Make sure that power source is turning off.

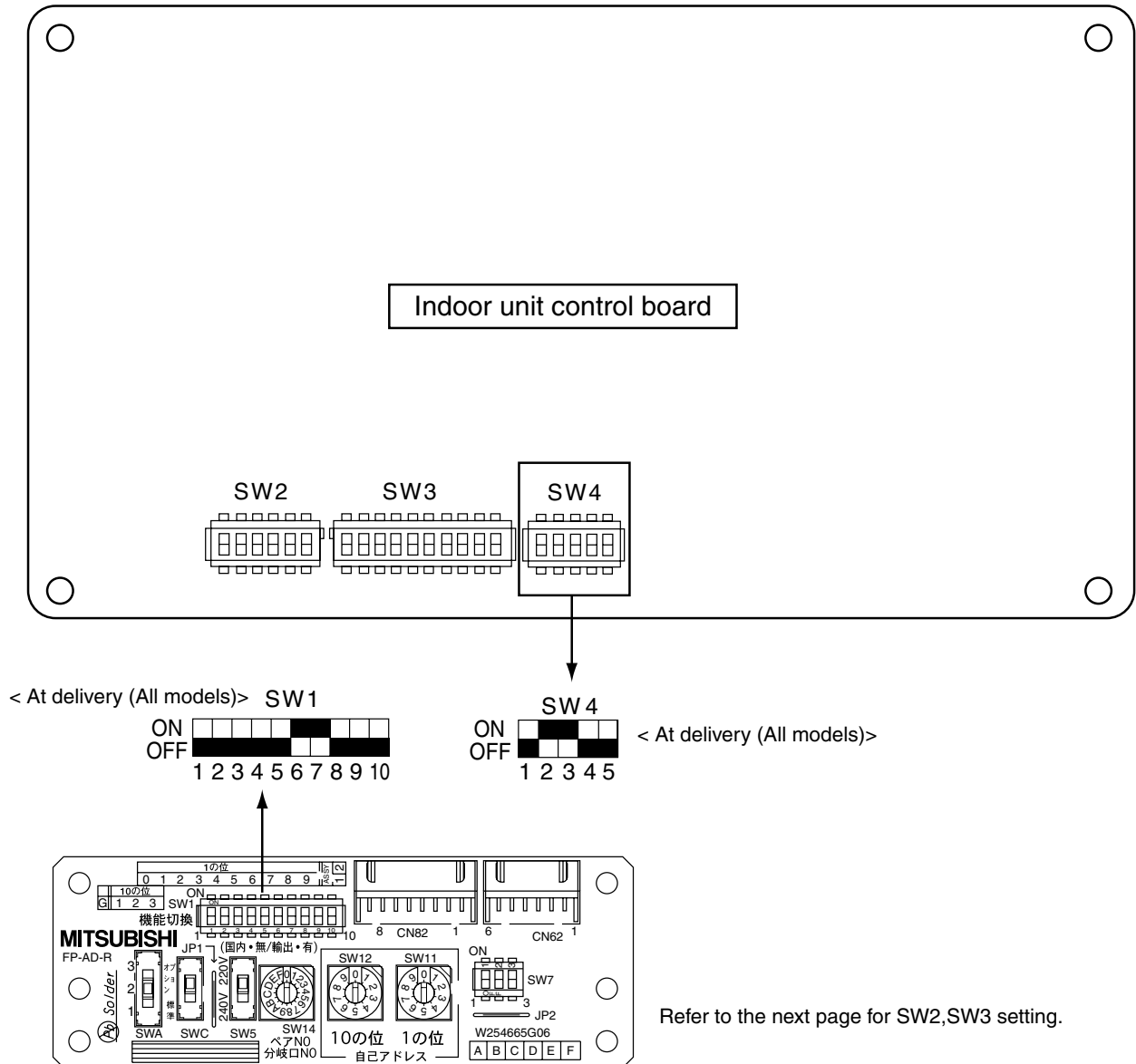

1) In case using network remote controller, address is set by rotary switches.(SW11,SW12)

* It is not necessary setting address in case of using unit remote controller.

Indoor unit do not run without address setting in field.

2) Indoor unit address setting rule is different by each field work.

Refer to install manual of outdoor unit , operate the address setting.

3) Setting the address is combination of SW11(1st digit address setting) and SW12(2nd digit address setting).

Address " 3 " setting is composed SW11 " 3 " and SW12 " 0 " .

Address " 25 " setting is composed SW11 " 5 " and SW12 " 2 " .

7-3. Setting of Dip-switch (at delivery)

| Models | Dip-SW | | | | | | | |
|---------------|---|--|---|--|---|----------|---------------------------|--|
| PEFY-P20VML-E | SW1 ON OFF <input type="checkbox"/> <input type="checkbox"/> <input type="checkbox"/> <input type="checkbox"/> <input type="checkbox"/> <input type="checkbox"/> <input type="checkbox"/> <input type="checkbox"/> <input type="checkbox"/> <input type="checkbox"/> <input type="checkbox"/> <input type="checkbox"/> 1 2 3 4 5 6 7 8 9 10 | SW2 ON OFF <input type="checkbox"/> <input type="checkbox"/> <input type="checkbox"/> <input type="checkbox"/> <input type="checkbox"/> <input type="checkbox"/> <input type="checkbox"/> <input type="checkbox"/> <input type="checkbox"/> <input type="checkbox"/> <input type="checkbox"/> <input type="checkbox"/> 1 2 3 4 5 6 | SW3 ON OFF <input type="checkbox"/> <input type="checkbox"/> <input type="checkbox"/> <input type="checkbox"/> <input type="checkbox"/> <input type="checkbox"/> <input type="checkbox"/> <input type="checkbox"/> <input type="checkbox"/> <input type="checkbox"/> <input type="checkbox"/> <input type="checkbox"/> 1 2 3 4 5 6 7 8 9 10 | SW4 ON OFF <input type="checkbox"/> <input type="checkbox"/> <input type="checkbox"/> <input type="checkbox"/> <input type="checkbox"/> <input type="checkbox"/> <input type="checkbox"/> <input type="checkbox"/> <input type="checkbox"/> <input type="checkbox"/> <input type="checkbox"/> <input type="checkbox"/> 1 2 3 4 5 | SW5 ON OFF <input type="checkbox"/> 220V <input type="checkbox"/> 240V | | | |
| PEFY-P25VML-E | SW1 ON OFF <input type="checkbox"/> <input type="checkbox"/> <input type="checkbox"/> <input type="checkbox"/> <input type="checkbox"/> <input type="checkbox"/> <input type="checkbox"/> <input type="checkbox"/> <input type="checkbox"/> <input type="checkbox"/> <input type="checkbox"/> <input type="checkbox"/> 1 2 3 4 5 6 7 8 9 10 | SW2 ON OFF <input type="checkbox"/> <input type="checkbox"/> <input type="checkbox"/> <input type="checkbox"/> <input type="checkbox"/> <input type="checkbox"/> <input type="checkbox"/> <input type="checkbox"/> <input type="checkbox"/> <input type="checkbox"/> <input type="checkbox"/> <input type="checkbox"/> 1 2 3 4 5 6 | SW3 ON OFF <input type="checkbox"/> <input type="checkbox"/> <input type="checkbox"/> <input type="checkbox"/> <input type="checkbox"/> <input type="checkbox"/> <input type="checkbox"/> <input type="checkbox"/> <input type="checkbox"/> <input type="checkbox"/> <input type="checkbox"/> <input type="checkbox"/> 1 2 3 4 5 6 7 8 9 10 | SW4 ON OFF <input type="checkbox"/> <input type="checkbox"/> <input type="checkbox"/> <input type="checkbox"/> <input type="checkbox"/> <input type="checkbox"/> <input type="checkbox"/> <input type="checkbox"/> <input type="checkbox"/> <input type="checkbox"/> <input type="checkbox"/> <input type="checkbox"/> 1 2 3 4 5 | SW5 ON OFF <input type="checkbox"/> 220V <input type="checkbox"/> 240V | SWA 1 | SWC “標準” (Standard) | |
| PEFY-P32VML-E | SW1 ON OFF <input type="checkbox"/> <input type="checkbox"/> <input type="checkbox"/> <input type="checkbox"/> <input type="checkbox"/> <input type="checkbox"/> <input type="checkbox"/> <input type="checkbox"/> <input type="checkbox"/> <input type="checkbox"/> <input type="checkbox"/> <input type="checkbox"/> 1 2 3 4 5 6 7 8 9 10 | SW2 ON OFF <input type="checkbox"/> <input type="checkbox"/> <input type="checkbox"/> <input type="checkbox"/> <input type="checkbox"/> <input type="checkbox"/> <input type="checkbox"/> <input type="checkbox"/> <input type="checkbox"/> <input type="checkbox"/> <input type="checkbox"/> <input type="checkbox"/> 1 2 3 4 5 6 | SW3 ON OFF <input type="checkbox"/> <input type="checkbox"/> <input type="checkbox"/> <input type="checkbox"/> <input type="checkbox"/> <input type="checkbox"/> <input type="checkbox"/> <input type="checkbox"/> <input type="checkbox"/> <input type="checkbox"/> <input type="checkbox"/> <input type="checkbox"/> 1 2 3 4 5 6 7 8 9 10 | SW4 ON OFF <input type="checkbox"/> <input type="checkbox"/> <input type="checkbox"/> <input type="checkbox"/> <input type="checkbox"/> <input type="checkbox"/> <input type="checkbox"/> <input type="checkbox"/> <input type="checkbox"/> <input type="checkbox"/> <input type="checkbox"/> <input type="checkbox"/> 1 2 3 4 5 | SW5 ON OFF <input type="checkbox"/> 220V <input type="checkbox"/> 240V | | | |

7-4. Function the LED of the indoor unit service board

| Symbol | Silk display | LED operation under normal state |
|--------|---------------------------|---|
| LED1 | Main power source | At applying main power source (indoor unit 200V) → Lighting |
| LED2 | Transmission power source | At receiving M-NET transmission power source → Lighting |

8-1. CONTROL BOX

Be careful on removing heavy parts.

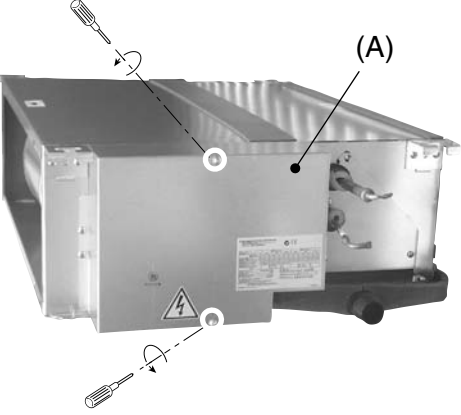
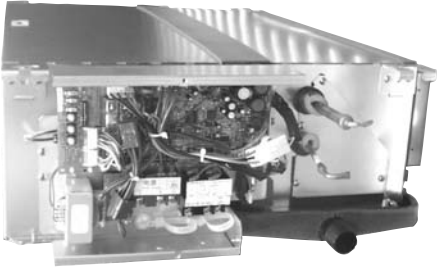
| OPERATING PROCEDURE | PHOTOS |
|---|--|
| <p>1.Removing the control box cover</p> <p>(1) Remove the fixing screws (two) of the control box (A), and remove the cover. (Fig. 1)</p> <p>*At this stage, the following servicing is possible.</p> <p>1 Operation and check of the switches (listed below) which are on the control board.</p> <ul style="list-style-type: none"> • Dip switch SW2 Capacity code setting • Dip switch SW3 Function change • Dip switch SW4 Model code setting <p>2 Operation and check of the switches (listed below) which are on the address board.</p> <ul style="list-style-type: none"> • Rotary switches SW11, 12 Address setting • Rotary switch SW14 Branch port setting • Dip switch SW1 Function change (main) <p>3 Connection check of the lead wires (listed below) which are connected to the controller board.</p> <ul style="list-style-type: none"> • Power supply lead wire. • Network remote controller transmission lead wire. • Fan motor lead wire. • LEV lead wire • Intake air sensor lead wire • Liquid piping sensor lead wire • Gas piping sensor lead wire • Power supply transformer lead wire • Address board lead wire <p>4 Control board exchange</p> <p>5 Address board exchange</p> <p>6 Condenser exchange</p> <p>7 Power supply transformer exchange</p> <p>8 Arrest exchange</p> <p>9 Intake air sensor exchange</p> <p>10 Power supply terminal bed exchange</p> <p>11 Transmission terminal bed exchange</p> | <p>fig.1</p>  <p>fig.2</p>  |



8-2. FAN and FAN MOTOR

Be careful on removing heavy parts.

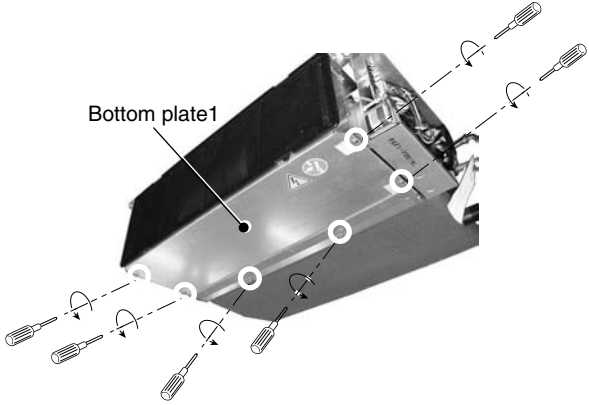
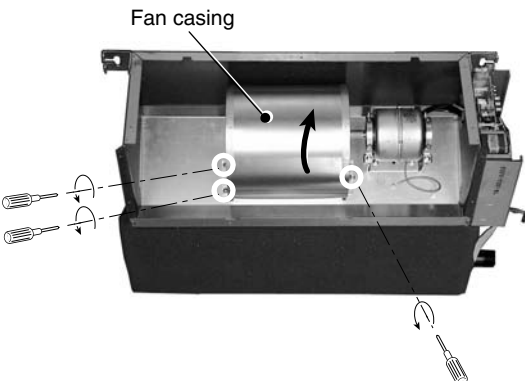
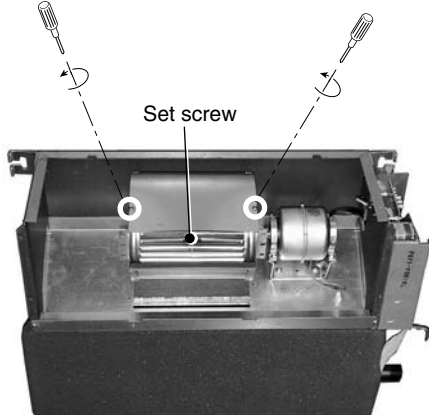
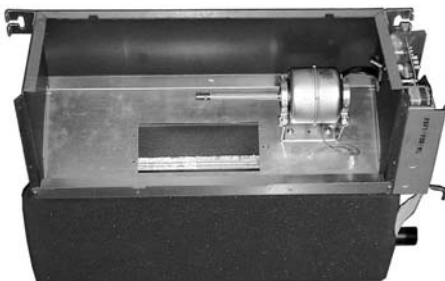
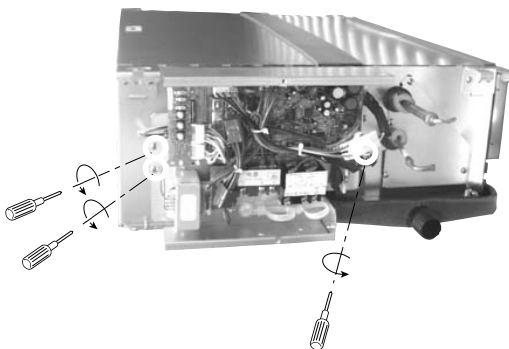
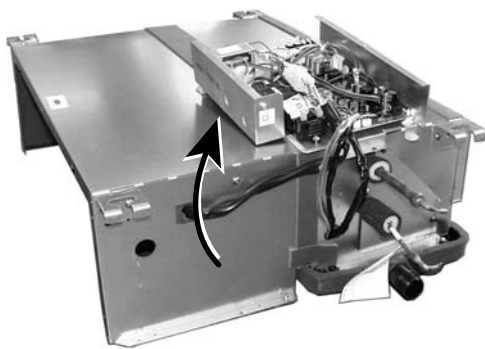
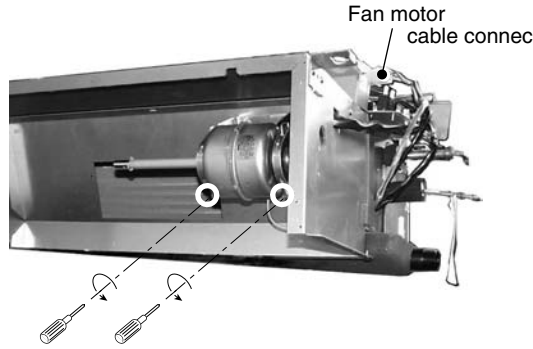
| OPERATING PROCEDURE | PHOTOS |
|--|--|
| <p>1.Removing the fan casing and sirocco fan.</p> <p>(1) Remove the bottom plate 1. (fixing screws : six) (Fig. 3)</p> <p>(2) Remove the fixing screws (three) of the fan casing, and turn it in direction of arrow. (Fig. 4)</p> <p>(3) Remove the fixing screws (two) of the fan casing, and loosen the set screw of the sirocco fan, and remove the fan casing and sirocco fan. (Fig. 5)</p> <p>2.Removing the fan motor.</p> <p>(1) Remove the control box. (fixing screws : three) (Fig. 7)</p> <p>(2) Move the control box to place that is not block operation. (Fig. 8)</p> <p>(3) Remove the fan motor cable connector in the control box, and remove the screws of the motor support. (Fig. 9)</p> | <p>fig.3</p>  |
| <p>fig.4</p>  | <p>fig.5</p>  |
| <p>fig.6</p>  | <p>fig.7</p>  |
| <p>fig.8</p>  | <p>fig.9</p>  |

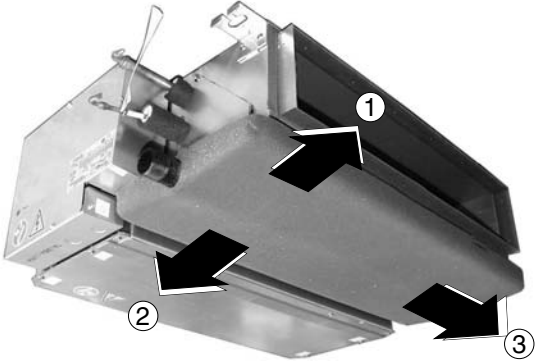

Be careful on removing heavy parts.

8-3. DRAINPAN

| OPERATING PROCEDURE | PHOTOS |
|--|--|
| <p>1.Removing the drainpan.</p> <p>(1) Remove the fixing screw (one) of the drainpan.(Fig. 10).</p> <p>(2) Slide the drainpan in the order of arrow ①,②,③, and remove the drainpan. (Fig. 11)</p> | <p>fig.10</p>  <p>fig.11</p>  |

8-4. LEV, THERMISTOR (Liquid/Gas piping temperature detection)

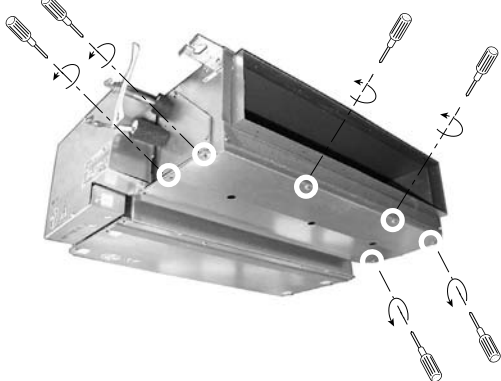
Be careful on removing heavy parts.

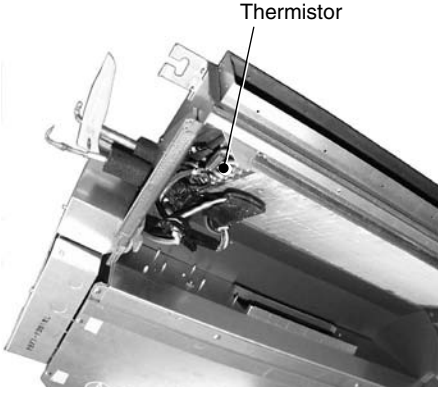
| OPERATING PROCEDURE | PHOTOS |
|--|--|
| <p>1. Removing the LEV.</p> <ol style="list-style-type: none">(1) Remove the drainpan with procedure 8-3.(2) Remove the bottom plate 2 (fixing screws : six), and remove the plate. (Fig. 12)(3) Remove the LEV driving motor with a double spanner. (Fig. 13) <p>2. Removing the thermistors.</p> <ol style="list-style-type: none">(1) Remove the thermistors from the thermistor holders which are installed on the piping. (Fig. 14) (liquid piping : fine piping , gas piping : thick piping) | <p>fig.12</p>  <p>fig.13</p>  <p>fig.14</p>  |

8-5. HEAT EXCHANGER

Be careful on removing heavy parts.

OPERATING PROCEDURE

1.Removing the heat exchanger.

- (1) Remove the drainpan with procedure 8-3.
- (2) Remove the bottom plate2 with procedure 8-4.
- (3) Remove the heat exchanger cover.(fixing screws : four)
(Fig. 15)
- (4) Remove the heat exchanger.(fixing screws : three)
(Fig. 16),(Fig. 17)

PHOTOS

fig.15

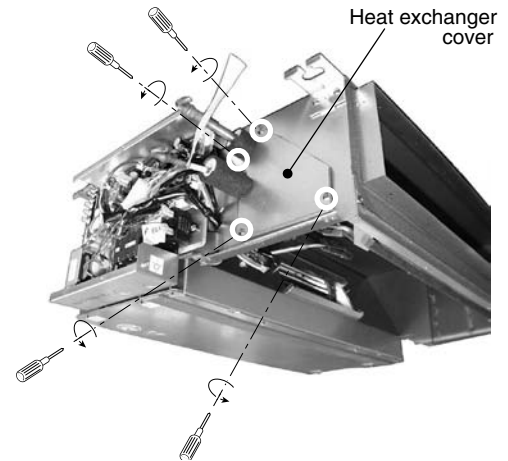

fig16

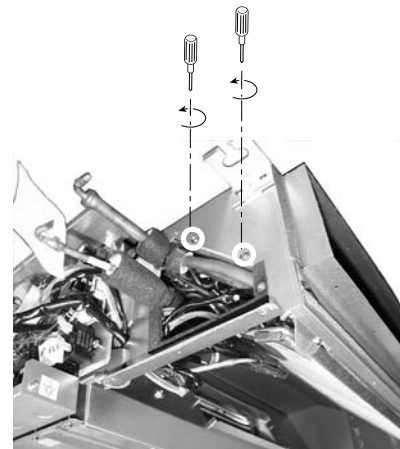
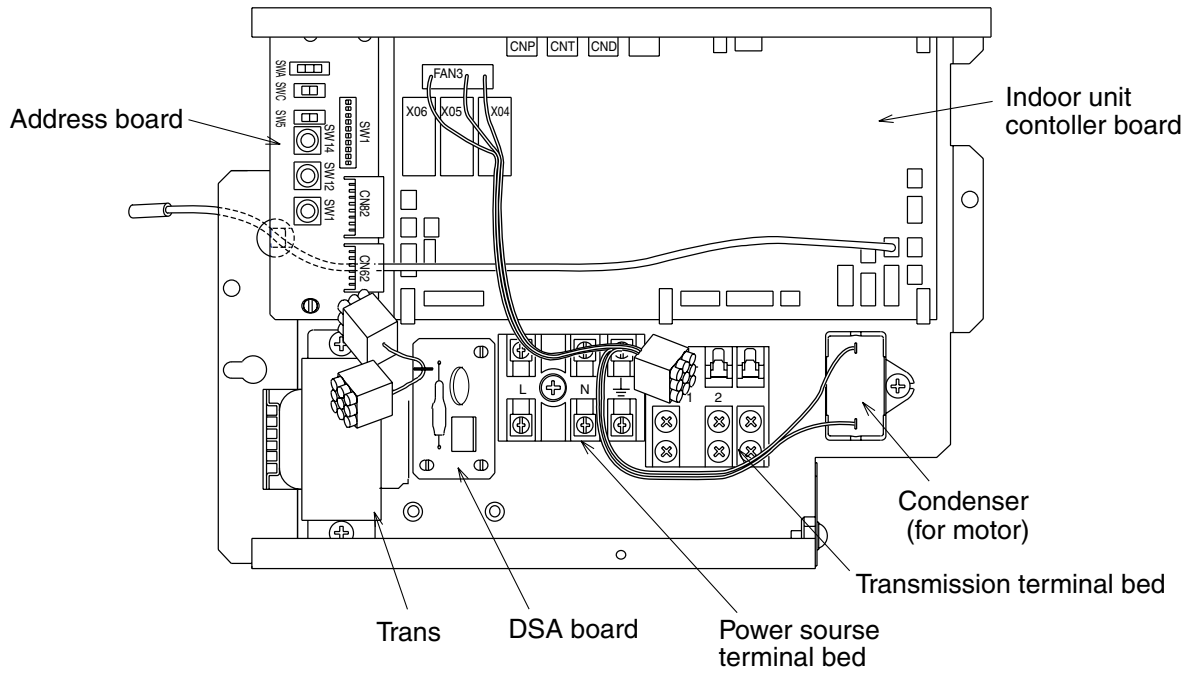

fig.17



8-6. CONTROL BOX INSIDE LAYOUT



8-7. SENSOR POSITION

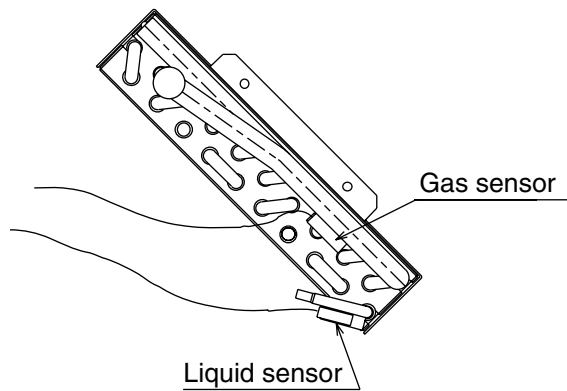



HEAD OFFICE: MITSUBISHI DENKI BLDG., 2-2-3, MARUNOUCHI, CHIYODA-KU, TOKYO 100-8310, JAPAN
