

Service Handbook PUD-P250YMF-C

PFD-P250VM-A
PFD-P500VM-A

Service Handbook Close Control PUD-P250YMF-C/PFD-P250, P500VM-A



AIR CONDITIONERS CITY MULTI

Service Handbook

 **MITSUBISHI ELECTRIC CORPORATION**
HEAD OFFICE: MITSUBISHI DENKI BLDG., 2-2-3, MARUNOUCHI, CHIYODA-KU, TOKYO 100-8310, JAPAN

Models < Outdoor unit >
PUD-P250YMF-C

< Indoor unit >
PFD-P250VM-A
PFD-P500VM-A

CITY MULTI

Contents

Please Read Before Servicing the Unit

1	Check Before Servicing the Unit.....	8
	[1] Find out the model type and refrigerant type of the unit to be serviced ..	8
	[2] Principal System Components	8
	[3] Check the symptoms of the unit requiring service	9
	[4] Be sure to read <i>Read Before Servicing</i> at the beginning of this manual ..	9
	[5] Prepare necessary tools	9
	[6] If the refrigerant circuit is opened (to repair gas leak etc.), the drier needs to be replaced	9
	[7] Preparing the connecting pipes: When relocating or replacing the unit, find out what types of refrigerant is used for the unit....	9
	[8] If there is a gas leak or if the remaining refrigerant is exposed to an open flame, a noxious gas hydrofluoric acid may form. Provide adequate ventilation	9
2	Necessary Tools and Materials	10
	[1] List of Tools and Materials Necessary for Units that Use R407C (and adaptability of tools that have been used with units that use R22).....	10
3	Piping Materials	11
4	Storage of Piping Materials.....	12
	[1] Storage Location	12
	[2] Pipe sealing before storage.....	12
5	Machining Pipes	13
6	Brazing	14
7	Testing Air Tightness.....	15
8	Vacuum Drying (Evacuating)	16
9	Charging the Circuit with Refrigerant	17
10	What to Do When Refrigerant Leaks	19
11	Replacing the Drier	19

I . Restrictions

1	System Restrictions and System Configuration	20
	[1] Switch Setting	20
2	Restrictions on Transmission Lines.....	22
	[1] Electrical Wiring	22
3	Restrictions on Refrigerant Pipe Length.....	38
	[1] Refrigerant Piping	38

II . Components of the Unit

1	Internal Structure	39
2	Control Box	42
3	Main Board	44

III . Electrical Wiring Diagrams

1	Outdoor Unit	49
2	Indoor Unit.....	50

IV . Refrigerant Circuit

1	Refrigerant Circuit Diagram	52
2	List of Major Component Functions	53

V. Control

1	Dip Switch Functions and Factory Settings	56
	[1] Outdoor Unit	56
	[2] Indoor Unit	57
2	Controlling the Outdoor Unit	58
	[1] Initial Control	58
	[2] Control at startup	58
	[3] Bypass control	58
	[4] Frequency Control	59
	[5] Oil-Return Control	60
	[6] Outdoor Unit Fan	60
	[7] Subcool Coil Control (Linear Expansion Valve (LEV1)).....	60
	[8] Circulating composition sensor (CS circuit).....	60
	[9] Emergency Operation Mode	61
	[10] Capacity Control Between Outdoor Units (For P500 Type Only)..	61
	[11] Control-Block Diagram.....	62
	[12] Operation Modes	62
3	Controlling the Indoor Unit	63
	[1] Thermostat Functions	63
	[2] Actuator Control.....	64
	[3] Temperature Setting Range.....	64
	[4] Emergency Operation Mode	64
	[5] Three-minute restart-suspension mode.....	65
	[6] Anti-Freeze Control	65
	[7] Operation during Electrical Power Failure	65
4	Operation Flow Chart	66
	[1] Mode Selection Flow Chart	66
	[2] Operation in each Mode	68

VI. Refrigerant Amount Adjustment

1	Operating Characteristics and Refrigerant Amount	69
	[1] Operating Characteristics/Refrigerant Amount	69
2	Checking and Adjusting Refrigerant Amount	69
	[1] Symptoms	69
	[2] Refrigerant Volume	69
	[3] Amount of Refrigerant to Be Added	70
3	Refrigerant-Adjustment Operation Mode	71
	[1] Procedures (only for air-cooled outdoor units)	71

VII. Troubleshooting

1	List of Check Code	73
2	Intermittent Fault Check Code (outdoor units only)	74
3	Self-Diagnosis and Problem-Solving Using Check Codes	75
	[1] Mechanical.....	75
	[2] Communication / System.....	86
	[3] System error	93
	[4] Troubleshooting using information on problems with Remote Control, Input from External Source	95
4	Transmission Wave Pattern and Noise Check	99
	[1] M-NET Transmission	99
	[2] MA Remote Controller Transmission	100
5	Troubleshooting.....	102
	[1] Principal Parts	102

VIII. LED Monitor Display

1	How to Read the Service Monitor LED.....	115
[1]	How to read the LED	115
[2]	Outdoor Unit Control LED Monitor.....	116

IX. Test Run

1	Before a Test Run	124
2	Test-Run Method.....	124
3	Not to Be Alarmed When the Following Symptoms Appear	125
4	Standard Operation (reference data)	126
[1]	Cooling Operation	126
[2]	Operation under Other Conditions.....	126

X. When Refrigerant Leaks

1	Repairing Leaks: Preparation, making repairs, and recharging the system with refrigerant	127
[1]	Location of leaks: Extension piping or indoor unit.....	127
[2]	Location of leaks: Outdoor unit	127

XI. Circulating Composition Analysis

1	Check the Composition of the Refrigerant	128
---	--	-----

Safety Precautions

- ▶ Before installing the unit, be sure to read all the “Safety Precautions” very carefully.
- ▶ They provide very important information regarding safety. Be sure to take these precautions to ensure safety.

<p>⚠ Warning: Failure to follow all instructions may result in serious personal injury or death.</p>
<p>⚠ Caution: Failure to follow all instructions may result in personal injury or damage to the unit.</p>

- ▶ **After reading this handbook, hand it over to those who will be using the unit.**
- ▶ **The user of the unit should keep this manual at hand and make it available to those who will be performing repairs, to those who will be relocating the unit, and to new users.**

⚠ Warning

<p>Have the unit professionally installed.</p>
<ul style="list-style-type: none"> • Improper installation by an unqualified person may result in water leak, electric shock, or fire.

<p>Be sure to carefully follow each step in this handbook when installing the unit.</p>
<ul style="list-style-type: none"> • Improper installation may result in water leak, electric shock, or fire.

<p>Place the unit on a stable, level surface that will withstand the weight of the unit to prevent the unit from toppling over.</p>
--

<p>Have all electrical work performed by a licensed electrician according to the local regulations and the instructions given in this manual. Secure a circuit designated exclusively to the unit.</p>
<ul style="list-style-type: none"> • Improper installation or a lack of circuit capacity at the power source presents a risk of electric shock or fire.

<p>Only use specified cables for wiring. Securely connect each cable, and make sure that the cables are not straining the terminals.</p>
<ul style="list-style-type: none"> • Cables not connected securely and properly may generate heat and cause fire.

<p>Securely attach the terminal cover (panel) on the unit.</p>
<ul style="list-style-type: none"> • If installed improperly, dust and/or water may enter the unit and fire or electric shock may result.

<p>Take necessary safety measures against typhoons and earthquakes to prevent the unit from toppling over.</p>

<p>Only use Refrigerant R407C.</p>
<ul style="list-style-type: none"> • The use of any other refrigerant or the introduction of air into the unit circuit may damage the unit.

<p>Do not make any changes or modifications to the unit. In case of problems, consult the dealer.</p>
<ul style="list-style-type: none"> • Inadequate repairs may result in water leak, electric shock, or fire.

<p>When installing the unit in a small room, safeguard against hypoxia, which is caused by the leaked refrigerant exceeding the threshold level.</p>
<ul style="list-style-type: none"> • Consult the dealer for necessary measures to take.

<p>Do not touch the fins on the heat exchanger with bare hands: they are sharp and dangerous.</p>
--

<p>When a gas leak is detected, provide adequate ventilation to the room.</p>
<ul style="list-style-type: none"> • If leaked refrigerant gas is exposed to a heat source, noxious gases may form.

<p>When relocating the air conditioner, consult the dealer or a specialist.</p>
<ul style="list-style-type: none"> • Improper installation may result in water leak, electric shock, or fire.

<p>Do not try to defeat the safety features of the devices, and do not change the settings.</p>
<ul style="list-style-type: none"> • Defeating the safety features such as the ones on pressure switch and temperature switch or using parts other than those specified by Mitsubishi Electric may result in fire or explosion.

<p>After completing service work, check for refrigerant gas leaks.</p>
<ul style="list-style-type: none"> • If leaked refrigerant gas is exposed to a heat source, such as fan heater, stove, and electric grill, noxious gases may form.

<p>Only use specified parts, and have the unit professionally installed.</p>
<ul style="list-style-type: none"> • Improper installation may result in water leak, electric shock, or fire.

Precautions for Devices that Use R407C Refrigerant

Caution

Do not use existing refrigerant piping.

- The old refrigerant and refrigerator oil in the existing piping contain a large amount of chlorine, which will deteriorate the refrigerator oil in the new unit.

Use a vacuum pump with a reverse-flow-check valve.

- If other types of valves are used, the vacuum pump oil will flow back into the refrigerant circuit and deteriorate the refrigerator oil.

Use refrigerant pipes made of C1220 phosphorus deoxidized copper categorized under H3000 (Copper and Copper Alloy Seamless Pipes and Tubes), a standard set by JIS.

- Keep inner and outer surfaces of the pipes clean and free of contaminants, such as sulfur, oxides, dust/dirt, shaving particles, oils, and moisture. Contaminants inside the refrigerant piping will deteriorate the refrigerant oil.

Do not use the following tools that have been used with the existing refrigerators. (Gauge manifold, charge hose, gas-leak detector, reverse-flow-check valve, refrigerant charge base, vacuum gauge, and refrigerant recovery equipment.)

- If refrigerant and / or refrigerant oil left on these tools are mixed in with R407 or if water is mixed with R407C refrigerant, the refrigerant will deteriorate.
- Since R407C does not contain chlorine, gas-leak detectors for conventional refrigerators will not work.

Store the piping to be used during installation indoors, and keep both ends of the piping sealed until immediately before brazing. (Keep elbows and other joints wrapped in plastic.)

- If dust, dirt, or water enters the refrigerant circuit, deterioration of the oil or compressor problems may result.

Do not use a charging cylinder.

- The use of charging cylinder will change the composition of the refrigerant and lead to power loss.

Use a small amount of ester oil, ether oil, or alkylbenzene to coat flares and flange connections.

- Refrigerator oil will deteriorate if it is mixed with a large amount of mineral oil.

Be especially careful when managing tools.

- Exercise caution so that tools do not introduce dust, dirt, and water into the refrigerant cycle.

Use liquid refrigerant to charge the circuit.

- Charging the unit with gas refrigerant will cause the refrigerant in the cylinder to change its composition and will lead to a drop in performance.

Only use R407C refrigerant.

- The use of other refrigerants containing chlorine (i.e. R22) will deteriorate the refrigerant.

Before Installing the Unit

Caution

Do not install the unit in a place where there is a possibility of flammable gas leak.

- Leaked gas accumulated around the unit may start a fire.

Do not use the unit to preserve food, animals, plants, or artifacts, or for other special purposes.

- The unit is not designed to provide adequate conditions to preserve the quality of these items.

Do not use the unit in an unusual environment.

- Installing the unit in a place where a large amount of oil, steam, or sulphurous gas is present may lead to a remarkable drop in performance and/or damage to the unit.

Use a closed circulating water circuit (which does not release water in the air) as a heat source.

- Water in an open circulating water circuit may become contaminated when exposed to air and lead to a drop in water-heat exchanger performance. It may also corrode the exchanger.

When installing the unit in hospitals, take necessary measures against noise interference.

- High-frequency medical devices may interfere with the normal operation of the air conditioning unit or vice versa.

Do not place the unit on or over things that should not get wet.

- When humidity level exceeds 80% or when the drainage system is clogged, indoor units may drip water. Installation of a centralized drainage system for the heat-source unit may also need to be considered to prevent water drips.

Make sure that the quality of circulating water meets the standards set by Mitsubishi based on the Guidelines for the Quality of Water for Refrigeration and Air Conditioning established by the Japan Refrigeration and Air Conditioning Industry Association.

- Using low-quality water may result in decreased performance of the water-heat exchanger or corrosion.

Heat-Source Unit is only to be installed indoors (including mechanical rooms). Make sure that the temperature around the heat-source unit does not exceed 40°CDB and that it is out of direct sunlight.

- A sharp rise in the temperature inside the unit may damage the unit.

Before Installing (Relocating) the Unit or Performing Electrical Work

Caution

Ground the unit.

- Do not connect the grounding on the unit to the grounding terminals of gas pipes, water pipes, lightning rods, or telephones. Improper grounding presents a risk of electric shock.

Make sure the wires are not subject to tension.

- If the wires are too taut, they may generate heat and cause fire.

Install a leak breaker at the power source to avoid the risk of electric shock.

For electrical wiring, use standard wires with proper current capacity to prevent electric leak, overheating, and fire.

Use breakers and fuses with proper current capacity. Do not use large-capacity fuses, steel wire, or copper wire, for they may damage the unit or cause fire.

Do not spray water on air conditioners. Spraying the unit presents a risk of electric shock.

Periodically check the platform on which the unit is placed for damage to prevent the unit from toppling over.

When installing draining pipes, follow the instructions in the manual and make sure that they properly drain water as to prevent dew condensation.

- If not installed properly, water may leak and damage the furnishings.

Before Installing (Relocating) the Unit or Performing Electrical Work

Caution

Exercise caution when transporting products.

- Do not try to move equipments over 20kg (approx. 44 lbs.) alone.
- Do not use the PP bands used on some packages for transportation.
- Wear protective gloves to avoid injury caused by coming in contact with the fins on the heat exchanger.
- When using suspension bolt to transport heat-source unit, use four-point suspension. Three-point suspension does not provide adequate stability and presents a risk of injury.

Properly dispose of packing materials.

- Things such as nails and wood pieces may be included in the package. Dispose of them properly to prevent injury.
- Plastic bags present a choking hazard to children. Tear up the plastic bags before disposing of them to prevent accidents.

Before the Test Run

Caution

Turn on the unit at least 12 hours before the test run, and keep the unit on throughout the season.

- If the unit is turned off during the season, problems may occur.

Do not turn off the power immediately after stopping the unit.

- Wait for at least five minutes; otherwise, the unit may leak water or experience other problems.

To prevent the risk of electric shock, do not operate switches with wet hands.

Do not operate the unit without air filters.

- Dust particles in the air may clog the system.

Do not touch refrigerant piping with bare hands during and immediately after operation.

- Depending on the state of the refrigerant in the system, refrigerator parts such as piping and compressor may become very hot or cold and may subject the person to frost bites or burning.

Do not operate the unit without panels and safety guards in their proper places.

- They are provided to keep the users from injury from accidentally touching rotating, high-temperature, or high-voltage parts.

Please Read Before Servicing the Unit

I Check Before Servicing the Unit

[1] Find out the model type and refrigerant type of the unit to be serviced.

PUD-P250YMF-C } Outdoor Unit

10HP(downward flow): PFD-P250VM-A(-H)
 20HP(downward flow): PFD-P500VM-A(-H) } Indoor Unit

- * 'H' in the indoor units indicates that the unit pipes come out of the top of the unit (50/60Hz, fit to order).
- * PFD-type indoor units cannot be connected to outdoor units other than the ones specified above.
- * PFD-type indoor units and other types of indoor units cannot coexist in the same refrigerant system.

[2] Principal System Components

<10HP System>

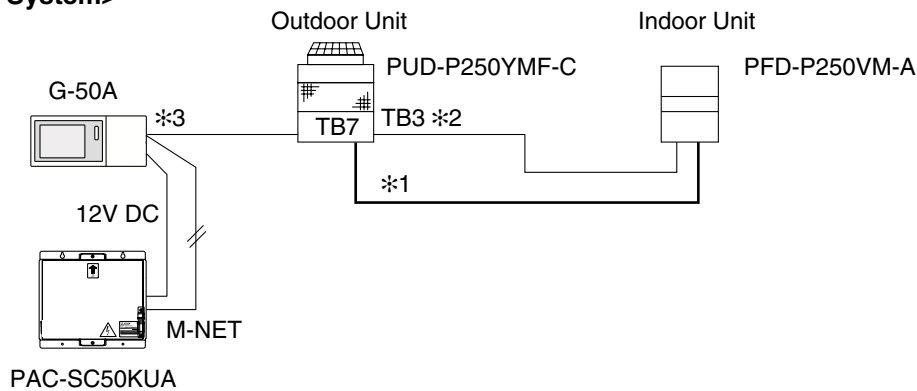

When using a PFD-P250VM-A as an indoor unit, connect an outdoor unit PUD-P250YMF-C to each indoor unit and operate with a built-in remote control for the indoor unit.

*1: Bold line indicates refrigerant piping (gas/liquid). This system consists of one refrigerant circuit.

*2: Indicates TB3-type transmission line that connects the indoor and outdoor units.

This system consists of 1 refrigerant circuit.

*3: Indicates TB7-Type transmission line that allows the unit to communicate with the controller.

<20HP System>

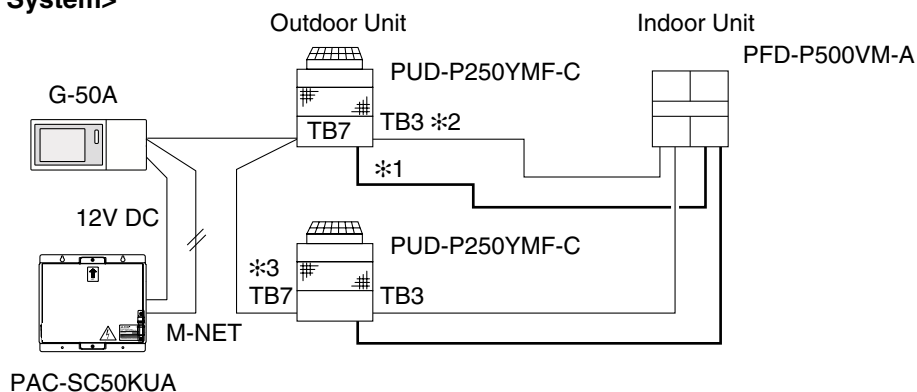

When using a PFD-P500VM-A as an indoor unit, connect 2 PUD-P250YMF-C outdoor units to each indoor unit and operate with a built-in remote control for the indoor unit.

*1: Bold line indicates refrigerant piping (gas/liquid). This system consists of 2 refrigerant circuits.

*2: Indicates TB3-type transmission line that connects the indoor and outdoor units.

This system consists of 2 refrigerant circuits.

*3: Indicates TB7-type transmission line that allows the unit to communicate with the controller.

[3] Check the symptoms of the unit requiring service.

Refer to this service manual for problems related to Freezer Cycle.

[4] Be sure to read *Read Before Servicing* at the beginning of this manual.

[5] Prepare necessary tools.

Do not use the same tools for units that use different types of refrigerant (especially gauze manifold and charge hose). Doing so may cause problems. Use a vacuum pump with a reverse-flow check valve or use a reverse flow check adapter.

[6] If the refrigerant circuit is opened (to repair gas leak etc.), the drier needs to be replaced.

Only use the drier designed specifically for the unit. The use of other driers may result in malfunctions. Refer to section 11 of this manual for information regarding how to change the drier.

※ Replace the drier after completing refrigerant circuit repairs.

(If left exposed to air, the drier will absorb moisture. Replace the drier as quickly as possible after removing the old one.)

[7] Preparing the connecting pipes: When relocating or replacing the unit, find out what types of refrigerant is used for the unit.

Use refrigerant pipes made of C1220 phosphorus deoxidized copper categorized under H3000 (Copper and Copper Alloy Seamless Pipes and Tubes), a standard set by JIS. Keep inner and outer surfaces of the pipes clean and free of contaminants, such as sulfur, oxides, dust/dirt, shaving particles, oils, and moisture. Contaminants inside the refrigerant piping will deteriorate the refrigerant oil.

[8] If there is a gas leak or if the remaining refrigerant is exposed to an open flame, a noxious gas hydrofluoric acid may form. Provide adequate ventilation.

⚠ Caution

1. As soon as the old parts are removed, put in the new ones. Keep moisture from entering pipes while cooling.
2. Using refrigerant containing chlorine (such as R22) will result in the deterioration of oil in the new unit.

2 Necessary Tools and Materials

Prepare the following tools and materials. Some of the tools should be marked for use only with units that use R407C refrigerant.

[1] List of Tools and Materials Necessary for Units that Use R407C (and adaptability of tools that have been used with units that use R22)

(1) To be used with R407C Only (not to be used if used with R22)

Tools	Use	Notes
Gauge Manifold	Evacuating, refrigerant charging and operation check	The ones with sight glass are useful.
Charge Hose		
Gas Leak Detector	Gas leak detection	Can also be used with R134a.
Refrigerant Collector	Refrigerant collection	
Refrigerant Cylinder	Refrigerant charging	Identification of dedicated use with R407C: Record refrigerant name and put a brown belt on the upper part of the cylinder.
Application Oil	Applied to flares and flanges	Use a small amount of ester oil, ether oil, or alkybenzene.

(2) Tools that may be used for R407C if necessary modifications are made

Tools	Use	Modifications to Be Made
Vacuum Pump	Vacuum drying	Attach a reverse-flow-check adaptor
Refrigerant Cylinder Intake	Refrigerant charging	Replace the packing with the one for R407C

(3) Tools that are used with R22 that can also be used with R407C

Tools	Use	Notes
Vacuum Pump with a Check valve		
Flare Tool	Flaring pipes	
Bender	Bending pipes	
Torque Wrench	Tightening flare nuts	
Pipe Cutter	Cutting pipes	
Welder and Nitrogen Cylinder	Welding pipes	
Refrigerant Charging Meter	Refrigerant charging	
Vacuum Gauze	Checking vacuum degree	

(4) Tools that must not be used for R407C

Tools	Use (with R22)	Notes
Charging Cylinder	Refrigerant Charging	Must not be used with R407C-type units

Tools for R407C must be handled with special care.

③ Piping Materials

Do not use the existing piping!

New Piping

Existing Piping

Do not use the piping that have been used for R22.

<Reason>

A large amount of chlorine residues from conventional refrigerator oil and refrigerant found inside the existing piping deposit sludge in the new piping system.

<Caution>

1. When replacing the air conditioner, also replace the piping.
2. Use refrigerant pipes made of C1220 phosphorus deoxidized copper categorized under H3000 (Copper and Copper Alloy Seamless Pipes and Tubes), a standard set by JIS. Keep inner and outer surfaces of the pipes clean and free of contaminants, such as sulfur, oxides, dust/dirt, shaving particles, oils, and moisture.
3. Contaminants inside the refrigerant piping may deteriorate the refrigerant oil.

4 Storage of Piping Materials

[1] Storage Location



Store the pipes to be used indoors (i.e. warehouse).
Storing them outdoors may cause dirt, waste, or water to infiltrate.

[2] Pipe sealing before storage

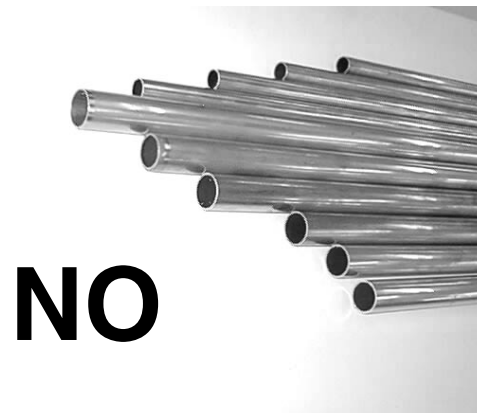
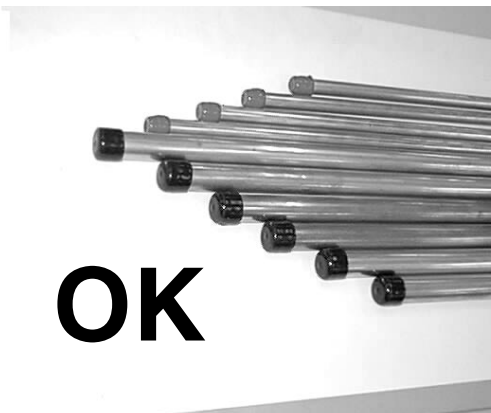

Both ends of the pipes should be sealed until immediately before brazing.
Wrap elbows and T's in plastic for storage.

* The new refrigerator oil is ten times more hygroscopic than conventional refrigerator oils (such as Suniso).
Water infiltration in the refrigerant circuit will deteriorate the oil or cause a compressor failure. Exercise more caution when handling piping materials for R407C air conditioners than you would when handling piping materials for conventional units.

5 Machining Pipes

Use a small amount of ester oil, ether oil, or alkylbenzene as refrigerator oil to coat flares and flange connections.



Do not use oils other than ester oil, ether oil, or alkylbenzene.

<Caution>

Use only the smallest possible amount of oil necessary.

6 Brazing

Although there are no changes from the conventional method, special care must be taken to keep contaminants (i.e. oxide scale, water, dirt etc.) from entering refrigerant circuit.

Example: Inside a brazed section

Brazed with materials other than non-oxide brazing material

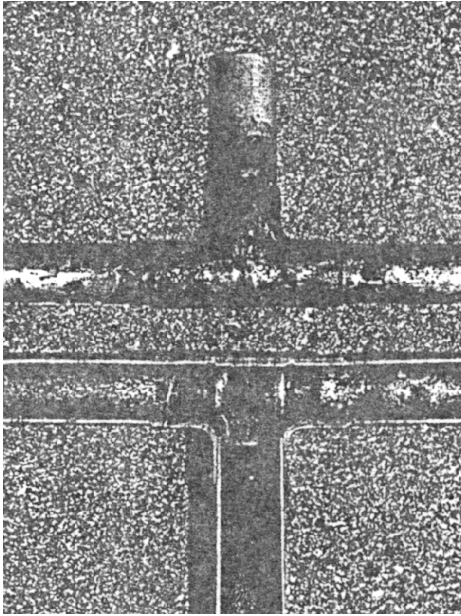

Brazed with non-oxide brazing material

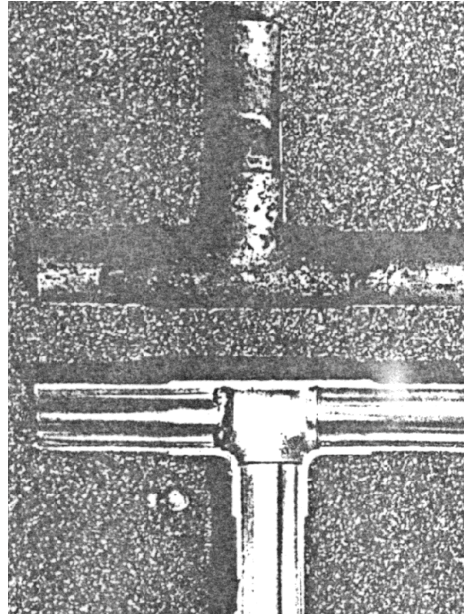

<Items to be strictly observed>

1. Do not conduct piping work outdoors on a rainy day.
2. Apply non-oxide brazing.
3. Use brazing material (BCuP-3), which requires no flux when brazing copper pipe or brazing a copper pipe and copper coupling.
4. If the installed refrigerant pipes are not immediately connected to the unit, braze and seal both ends of the pipes.

<Rationale>

1. The new refrigerant oil is ten times more hygroscopic than conventional oils. Special care must be taken to keep moisture out of the system.
2. Flux generally contains chlorine. A residual flux in the refrigerant circuit may deposit sludgy materials in the pipes.

<Caution>

Because the residue found in commercially available antioxidants may have adverse effects on the unit, use nitrogen when performing non-oxide brazing.

7 Testing Air Tightness

There are no changes from the conventional method. Note that a refrigerant leak detector for R22 will not work for R407C.

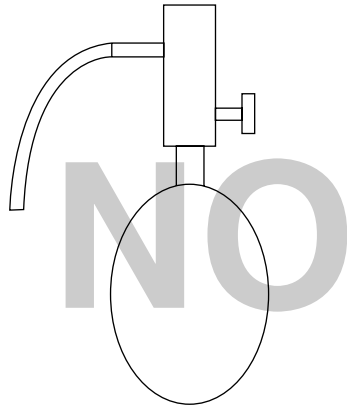

Halide Torch

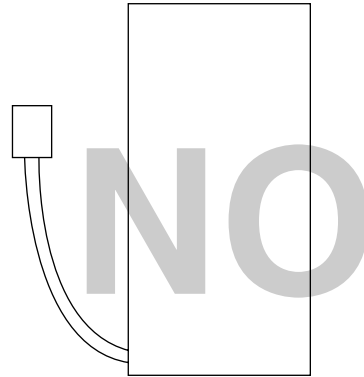

R22 Leak Detector

<Items to be strictly observed>

1. Pressurize the equipment with nitrogen up to the design pressure, and then measure the equipment's air-tightness, taking temperature variations into account.
2. When investigating locations of leaks using a refrigerant, be sure to use R407C.
3. Make sure that R407C is in a liquid state when charging the circuit.

<Rationale>

1. Use of oxygen to pressurize the equipment may cause an explosion.
2. If gas refrigerant is used, the composition of the remaining refrigerant in the cylinder will change and become unusable.

<Caution>

A leak detector for R407C is commercially available, and it should be acquired.

8 Vacuum Drying (Evacuating)

Photograph 1



15010H

Photograph 2



14010

Photograph 1 Recommended Vacuum Gauge : ROBINAIR 14010 Thermistor Vacuum Gauge

[1] Vacuum pump with a check valve (See photo 1)

A vacuum pump with a check valve is required to prevent the vacuum pump oil from flowing back into the refrigerant circuit when the power supply is cut off unexpectedly due to power outage. A check valve may be added to a vacuum pump that is not equipped with one.

[2] Standard degree of vacuum for the vacuum pump

Use a pump that does not exceed 65Pa after 5 minutes of operation. Be sure to use a vacuum pump that has been properly maintained and oiled with specified oil. If the vacuum pump is not properly maintained, desired degree of vacuum may not be achieved.

[3] Necessary Accuracy of the Vacuum Gauge

Use a vacuum gauge that can measure 650Pa and in the increments/decrements of 130Pa. Do not use gauge manifolds that cannot measure a vacuum of 650Pa. (Recommended vacuum gauge shown in Photograph 2 above)

[4] Vacuuming time

Evacuate the equipment for one hour after reaching 650Pa. (Moisture in the air will be removed by a thorough evacuation.)

After evacuating, leave the equipment for one hour and make sure that degree of vacuum does not rise higher than 130Pa. Refer to section 6 "Special Vacuuming Method" if it exceeds 130Pa.

[5] How to Stop the Vacuum Pump

In order to prevent a backflow of the vacuum pump oil, open the relief valve on the vacuum pump or loosen the charge hose to draw in air before stopping the operation. The same operating procedure should be followed when using a vacuum pump with a check valve.

[6] Special Vacuuming Method

Water infiltration or leakage is suspected when the degree of vacuum does not go below 650Pa after running the vacuum pump for more than 3 hours. Check for leakage and water infiltration.

If water infiltration is the suspected cause, break vacuum with nitrogen. Then, pressurize nitrogen gas to 0.05MPa and try evacuating again. Repeat the procedure until the degree of vacuum goes below 650Pa or until the pressure stops rising.

Be sure to use nitrogen to break vacuum. (The use of oxygen may cause an explosion)

9 Charging the Circuit with Refrigerant

R407C must be in a liquid state when charging the circuit because it is a non-azeotropic refrigerant.

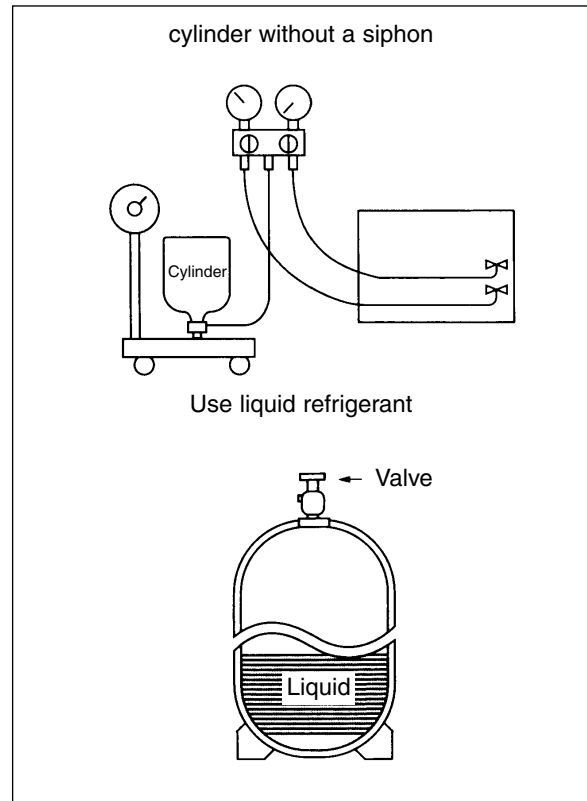
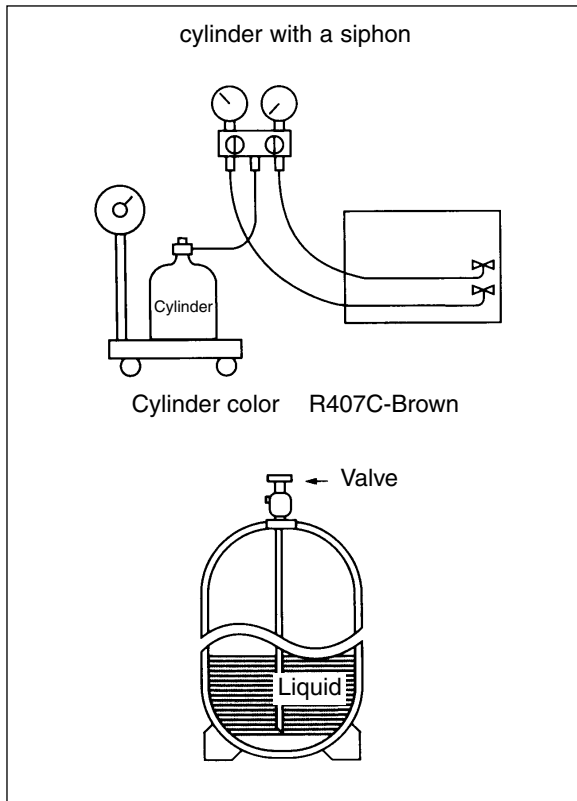

<Rationale>

1. R407C is a mixture of three refrigerants, each with a different evaporation temperature. If the equipment is charged with R407C gas, only the refrigerant that evaporates most easily is charged, while the rest of the refrigerants remain in the cylinder.

<Caution>

Do not use cylinders with a siphon upside-down.

When using a cylinder with a siphon, R407C is charged in a liquid state without the cylinder being turned upside-down. Check the label on the cylinder for information about the type of cylinder before the operation. (Cylinders with siphons manufactured by Asahi Glass are shown on Page 18)

⚠ Caution

The cylinders shown below are equipped with siphons. When using this type of cylinders, place the cylinder with the siphon facing up.

Enlargement

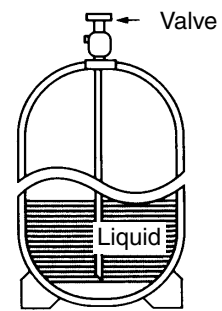
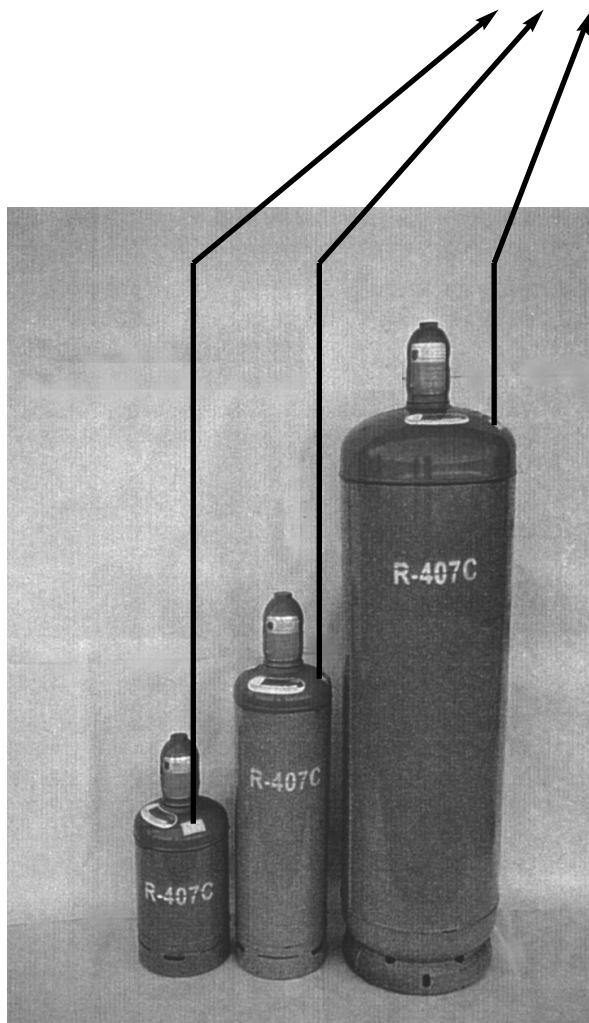

R407C Cylinder with siphon: Manufactured by Asahi Glass

10 What to Do When Refrigerant Leaks

As with conventional air-conditioning units, refrigerant can be added to what remains in the circuit, for the unit is equipped with a CS circuit (Circulating-Refrigerant-Composition-Detector) Refer to section X of this handbook for more information.

※ When using water-cooled heat-source unit, please note that CS circuit is only found on the inverter side, but not on the constant-rate side.

11 Replacing the Drier

1. Replace the drier when the refrigerant circuit is opened. Only use the drier specified for this unit. The use of any other drier will cause malfunctions.
2. Install the drier as shown in the photograph below. Do not attach driers to a pipe; doing so may cause problems.
3. Do not leave the refrigerant circuit open for longer than one hour after removing the old drier. The replacement of the drier should be performed last when performing multiple jobs.

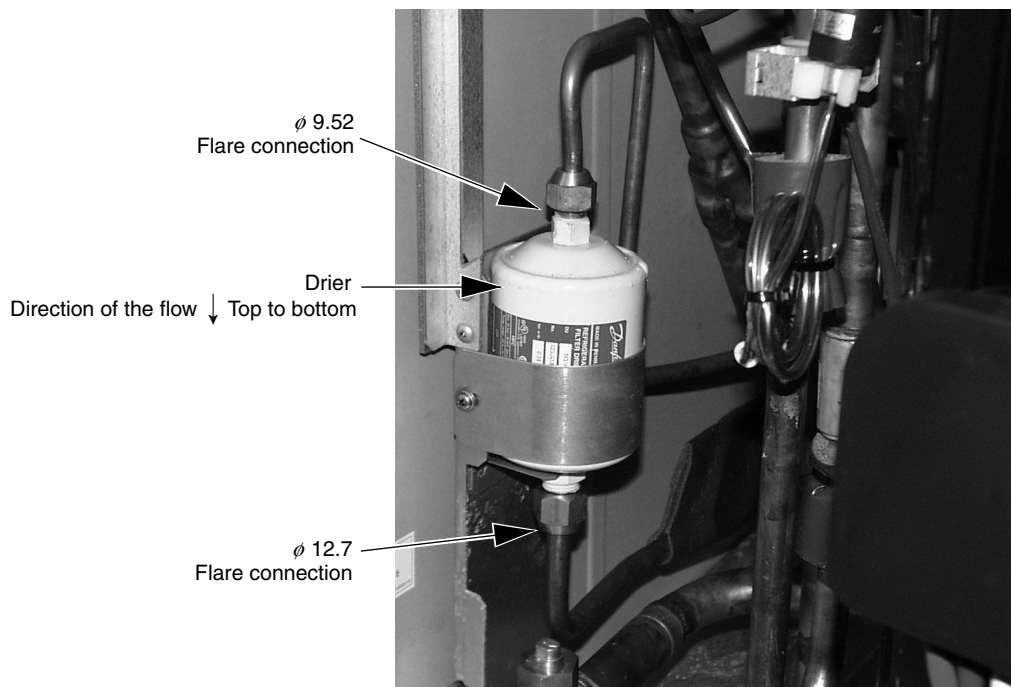

I . Restrictions

1 System Restrictions and System Configuration

Each unit of the Split-Type Air Conditioners for Computer Rooms comes as a part of a system. For each unit to be integrated into the system, the system requires a series of switch setting. Be sure to read the following to properly configure the system.

[1] Switch Setting

(1) Types of Switches

	Type	Outdoor Unit	Indoor Unit
Address Switch	rotary	○	○ ※1
Power-Source Switch Connector	4-Pin connector CN40	○	

※ Inside indoor units, there is a control board for each refrigerant system.
Be sure to set the address for each of the control board.

(2) Notes on Switch Setting

- ① Cut off the power supply before changing switch settings.
If the settings are changed while power is supplied to the unit, the change will not take effect, and it will cause the unit to malfunction.

Switches to Be Operated	Cut off the power supply to
Outdoor Unit	Outdoor unit
Indoor Unit	Outdoor and Indoor Units

- ② Two or more identical addresses cannot coexist in the same system. If two or more of the same address are used, the unit will not run properly.

(3) How to Set the Switches

- ① Address Switch

Unit Type	Setting Range	Digits	Setting Method	Factory Setting
Indoor Unit	1-50	2 (the hundred's digit is always set to 0)	<ul style="list-style-type: none"> · Use numbers between 1-50. · All the indoor units controlled by the same centralized controller should be assigned sequential numbers starting with 01. · Only use odd numbers to set the top controller of the indoor unit. · To set the bottom controller of indoor units, add one to the address of the top controller in the same unit. If P250 and P500 systems coexist, Refer to P34. 	00
Outdoor Unit	51-100	2 (the hundred's digit is always set to 0)	<ul style="list-style-type: none"> · The address for the outdoor unit should equal the address of the indoor controller address in the same refrigerant system plus 50. 	00

(4) Example

Below is a typical setting of a system

Diagram	Comments								
<p>The diagram illustrates a multi-zone HVAC system. On the left, a 'Controller board' section contains a 'G-50A' board, a 'DC12V Power supply line', and a 'Power supply unit'. The system is divided into three groups of units:</p> <ul style="list-style-type: none"> Group 1: Four outdoor units (51, 52, 53, 54) are connected to four indoor units (01, 02, 03, 04). A note states: '* There are two controller boards inside indoor units. (for P500 type)'. Group 2: Three outdoor units (55, 56, 57) are connected to three indoor units (05, 06, 07). Group 3: One outdoor unit (59) is connected to one indoor unit (09). A note states: '* There are one controller board inside indoor units. (for P250 type)'. <p>At the bottom, a switch setting table is provided:</p> <table border="1" style="margin-left: auto; margin-right: auto;"> <tr> <td>SW12</td> <td>SW11</td> </tr> <tr> <td style="text-align: center; font-size: 2em;">0</td> <td style="text-align: center; font-size: 2em;">1</td> </tr> <tr> <td style="text-align: center;">10's Digits</td> <td style="text-align: center;">Single digits</td> </tr> <tr> <td colspan="2" style="text-align: center;">Unit Address</td> </tr> </table>	SW12	SW11	0	1	10's Digits	Single digits	Unit Address		<p>Switch Setting</p> <ol style="list-style-type: none"> ① Set indoor unit address using sequential numbers. (P500 only) ② To set the address for the outdoor unit, add 50 to the address for the indoor unit to which the outdoor unit is connected.
SW12	SW11								
0	1								
10's Digits	Single digits								
Unit Address									

2 Restrictions on Transmission Lines

[1] Electrical Wiring

(1) Attention

- ① Follow ordinance of your governmental organization for technical standard related to electrical equipment, wiring regulations, and guidance of each electric power company.
- ② Wiring for control (hereinafter referred to as transmission line) shall be (5cm or more) apart from power source wiring so that it is not influenced by electric noise from power source wiring.(Do not insert transmission line and power source wire in the same conduit.)
- ④ Give some allowance to wiring for electrical part box of indoor and outdoor units, because the box is sometimes removed at the time of service work.
- ⑤ Never connect 380~415V(220~240V)power source to terminal block of transmission line.If connected,electrical parts will be burnt out
- ⑥ Use 2-core shield cable for transmission line. If transmission lines of different systems are wired with the same multicore cable, the resultant poor transmitting and receiving will cause erroneous operations.

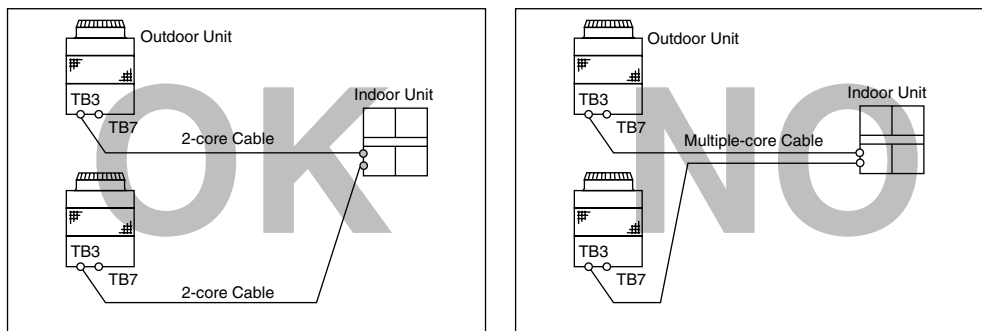

(2) Control Box and Location of Terminals

① Outdoor Unit

- a) Remove the service panel by unscrewing the 6 screws as shown in the picture on the right.

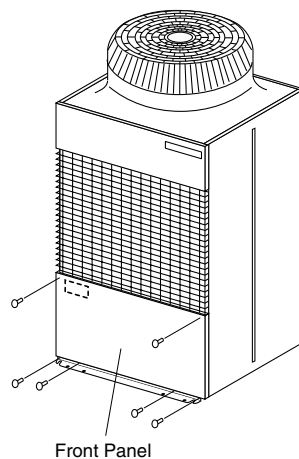

- b) The control box cover consists of two parts (top and bottom parts). Each can be removed separately by unscrewing two screws and pulling the cover down. Connectors and dipswitches on the main board can be operated by removing only the top part. Only remove the bottom part when servicing power supply lines and transmission lines.

② How to Use Conduit Mounting Plates

Conduit mounting plates (ϕ 27, ϕ 33, ϕ 40) are packaged with the unit. Use an appropriate plate depending on the diameter of the wire used. Mount the plate as shown below.

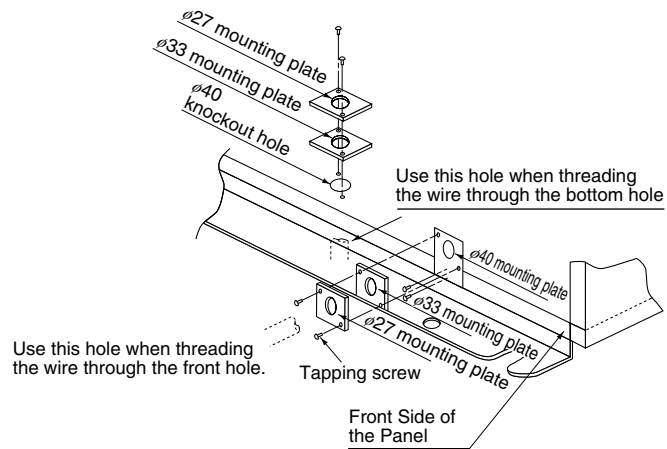

③ How to Mount the Attachment Plate

When using either the left or front knock-out holes for both power-supply line and transmission line, screw on an attachment plate with two screws (see below). Fix the power-supply line with the bottom clamp, and fix the transmission line with the top clamp.

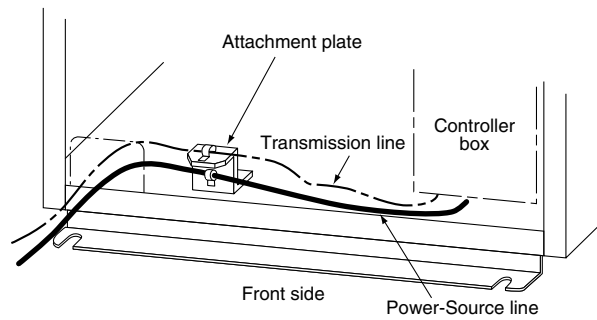

(3) Control Wiring

Transmission line is a type of control line. When the source of noise is located adjacent to the unit, the use of shield cable as well as moving the unit as far away from the noise source are recommended.

① Transmission line (M-NET transmission line)

System component		For multiple-refrigerant system
Wiring specifications	Length of transmission line	n/a
	Facility type (noise level measurement)	All types of facilities
	Cable type	Shield cable CVVS - CPEVS
	No. of cable	2-core cable
	Diameter	Over 1.25mm ²
Total length of indoor/outdoor transmission line		Maximum length: 200m Maximum length of centralized control transmission line and Indoor/Outdoor transmission line via indoor/outdoor units: 500m maximum

② Remote control wiring

		MA remote controller ※ 1
Wiring specifications	Cable type	CVV
	No. of cable	2-core cable
	Diameter	0.3~1.25mm ² ※ 2 (0.75~1.25mm ²) ※ 3
Total Length		Maximum length: 200 m

※ 1: "MA remote controller" includes MA remote controller, Simple MA controller, and wireless remote controller.

※ 2: Cables with a diameter of 0.75mm² or smaller recommended for easier handling.

※ 3: When connecting to simple remote controller terminal, use a cable with a diameter within the range shown in the parenthesis.

(4) Types of switch settings and setting methods

Whether a particular system requires switch settings depends on its components. Refer to the section "(5) Examples" before conducting electrical work.

Keep the power turned off while setting the switches. If settings are changed while being powered, the changed settings will not register, and the unit may malfunction.

Unit		Symbol	Turn off the power to
Outdoor unit		OC	Outdoor unit
Indoor unit	Main/sub controllers ※	IC	Indoor and outdoor units

※ 10HP has only the main controller

① Address setting

This system requires address setting. The range of address varies depending on the type of unit. Refer to “(5) Examples” for details.

Unit		Symbol	Address setting range	Setting method	Factory setting
Indoor unit	Main/sub controllers * 1	IC	01~50 * 2	Assign a number to all indoor units, starting with 1 and using sequential numbers. Use odd numbers for the top controller and even numbers for the bottom controller of the indoor units. Use odd numbers starting with 01 for 10HP system.	00
Outdoor Unit		OC	51~100 * 2 * 3	Add 50 to the address assigned to the indoor unit to which the outdoor or heat-source unit is connected.	00

* 1: 10HP only has the main controller.

* 2: Avoid using the same address as the ones used by the indoor/outdoor units in another refrigerant system; choose a different one in the range specified above.

* 3: When setting the address to 100, set the switch to 50.

② Setting the outdoor unit power-source switch connector (Factory setting: CN41 Connected)

System component	Power supply switch unit
Multiple-refrigerant system	<p><When power-supply unit is not connected to the centralized control transmission line> Replace the power source switch connector CN41 with CN40 on only one of the outdoor units</p> <p><When connecting the power-supply unit> Use CN41 as it is.</p>

③ Choosing the temperature detection spot by indoor unit (Factory Setting: SWC “Standard”)

When using the suction temperature sensor, set SWC to “Option.”

④ Setting the MA “Sub” controller

When using two remote controllers or running two indoor units as a group, one of the controllers must be set to “Sub” controller.

* No more than two remote controllers can be connected to a group.

(Factory setting: “Main”)

Set the controller according to the following procedure. Refer also to the instructions manual supplied with the MA remote controller.

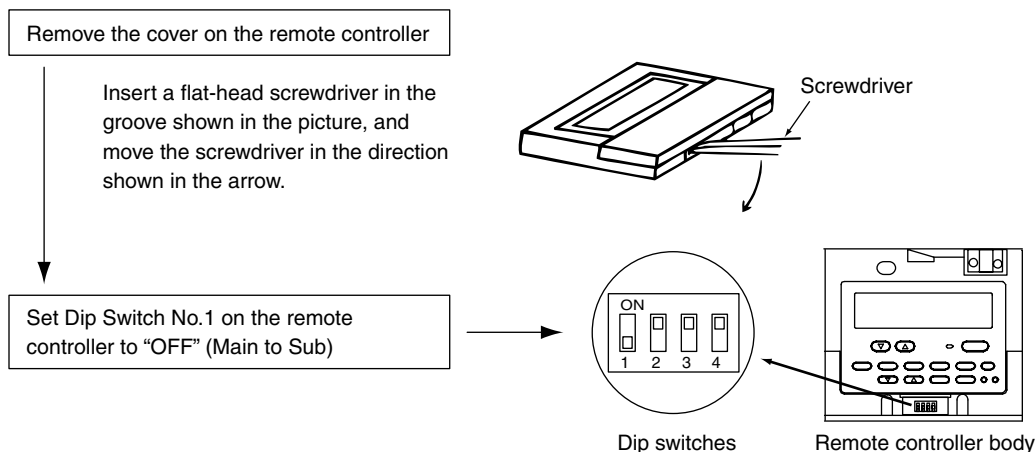

(5) Examples

- ① System Using MA Remote Controller
 - (1) System with one indoor unit (10HP system)

Control Wiring Diagram

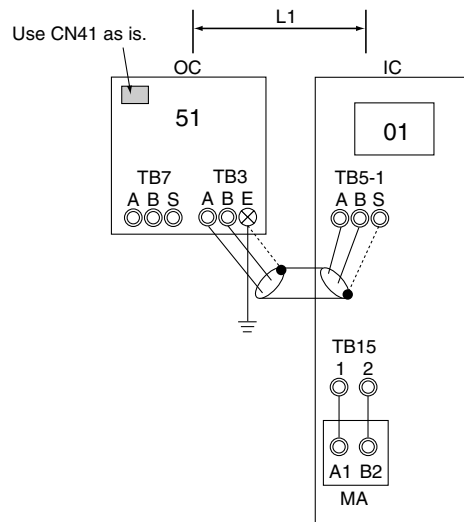

*There is one indoor controller board inside indoor unit.

Remarks

1. Use power supply connector (CN41) on the outdoor unit as is.
2. It is not necessary to ground the S terminal of centralized control transmission terminal board (TB7) on the outdoor unit.
3. The outdoor unit cannot be connected to indoor units other than the PFD-type ones.

Maximum Allowable Length

<a. Indoor/Outdoor transmission line>
 Maximum Length (above 1.25mm²)
 $L1 \leq 200\text{m}$

Wiring and Address Setting

<a. Indoor/Outdoor Transmission Lines >

Connect A, B terminals of indoor/outdoor transmission line terminal board (TB3) on the outdoor unit and A, B terminals of the Indoor/outdoor transmission terminal board (TB5). (Non-polar 2 wire)

* Only use shield line.

[Grounding the shield line]

Connect the earth terminal of the OC and S terminal of the IC terminal board (TB5).

<b. Switch Setting >

Set the address as follows.

Steps	Unit or Controller			Address Setting Range	Setting Procedures	Remarks	Factory Setting
1	Indoor Unit	Main Unit	IC	01 ~ 50	Set the address for the controller at the top of the indoor unit. Start with "01" then use sequential odd numbers (i.e.01, 03, 05).		00
2	Outdoor Unit		OC	51 ~ 100	Add 50 to the address assigned to the indoor unit within the same refrigerant system.		00
3	MA remote controller	Main Controller	MA	n/a	-		Main
		Sub Controller	MA	Sub controller	Use dipswitch to set the controller as sub controller.		

- ① System Using MA Remote Controller
 (2) Unit with One Indoor Unit (20HP Systems)

Control Wiring Diagram

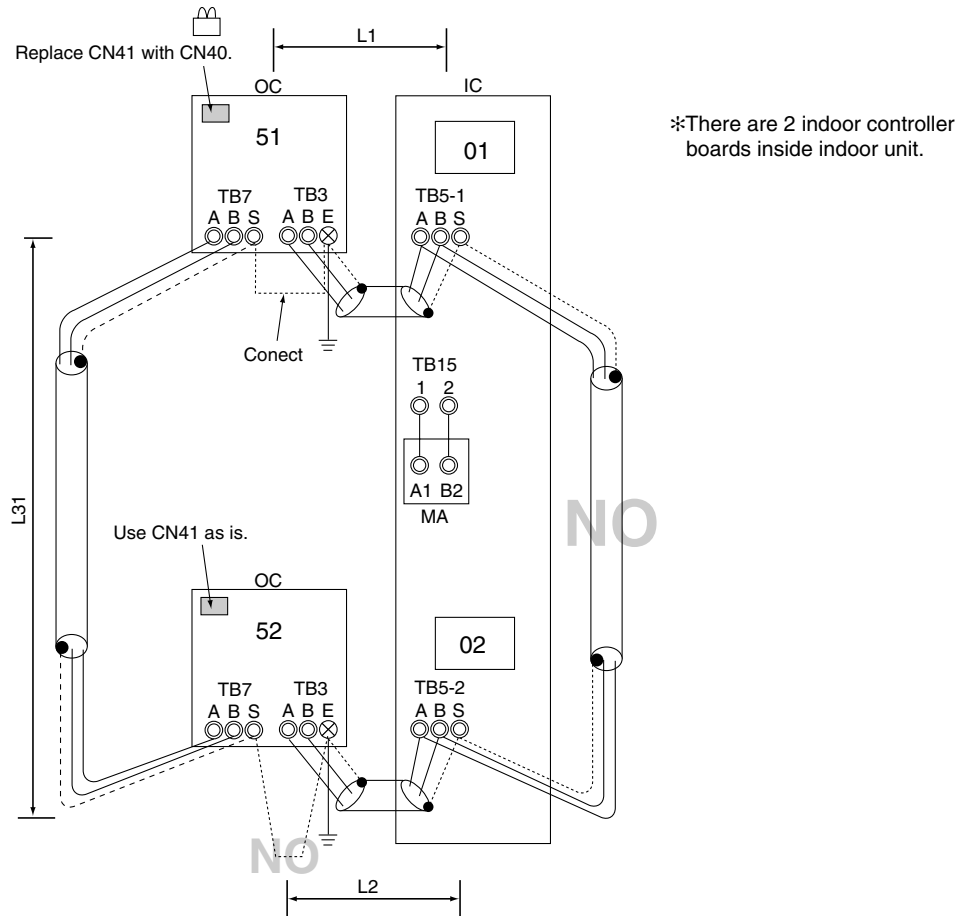

Remarks

1. Use sequential numbers to set indoor unit address.
2. Do not connect TB5s' of the indoor units that are connected to different outdoor units with each other.
3. Replace CN41 with CN40 on only one outdoor unit.
4. Ground only one of the outdoor units' S terminal of TB7 (centralized control transmission terminal).
5. The outdoor unit cannot be connected to indoor units other than the PFD-type ones.

Maximum Allowable Length

- <a. Indoor/Outdoor transmission line>**
 Maximum Length (above 1.25mm²)
 $L1, L2 \leq 200\text{m}$
- <b. Transmission line for centralized control>**
 Maximum length via outdoor unit (over 1.25mm²)
 $L1 + L3 + L2 \leq 500\text{m}$

Wiring and Address Setting

<a. Indoor/Outdoor Transmission Lines >

Connect A, B terminals of indoor/outdoor transmission line terminal board (TB3) on the outdoor unit and A, B terminals of the Indoor/outdoor transmission terminal board (TB5). (Non-polar 2 wire)

*Only use shield line.

[Grounding the shield line]

Connect the earth terminal of the OC and S terminal of the IC terminal board (TB5).

<b. Transmission Line for Centralized Control >

Connect A terminals of centralized control transmission line terminal board on each of the outdoor units with each other.

Do the same with B terminals. Replace CN41 (power supply switch connector) with CN40 on only one OC.

*Only use shield line.

[Grounding the shield line]

Connect S terminals of the TB7 of each of the outdoor units with each other.

Connect the S terminal of TB7 on the outdoor unit whose CN41 was replaced with CN40 to the earth terminal of the electric box.

<c. Switch Setting >

Set the address as follows.

Steps	Unit or Controller		Address Setting Range	Setting Procedures	Remarks	Factory Setting
1	Indoor Unit	Main Unit	IC	01 ~ 49	Set the address for the controller at the top of the indoor unit. Start with "01" then use sequential odd numbers (i.e.01, 03, 05).	00
		Sub Unit	IC	02 ~ 50		
2	Outdoor Unit		OC	51 ~ 100	Add 50 to the address assigned to the indoor unit within the same refrigerant system.	00
3	MA remote controller	Main Controller	MA	n/a	-	Main
		Sub Controller	MA	Sub controller	Use dipswitch to set the controller as sub controller.	

① System Using MA Remote Controller

(3) When connecting 2 MA remote controller to one indoor unit (20HP Systems)

Control Wiring Diagram

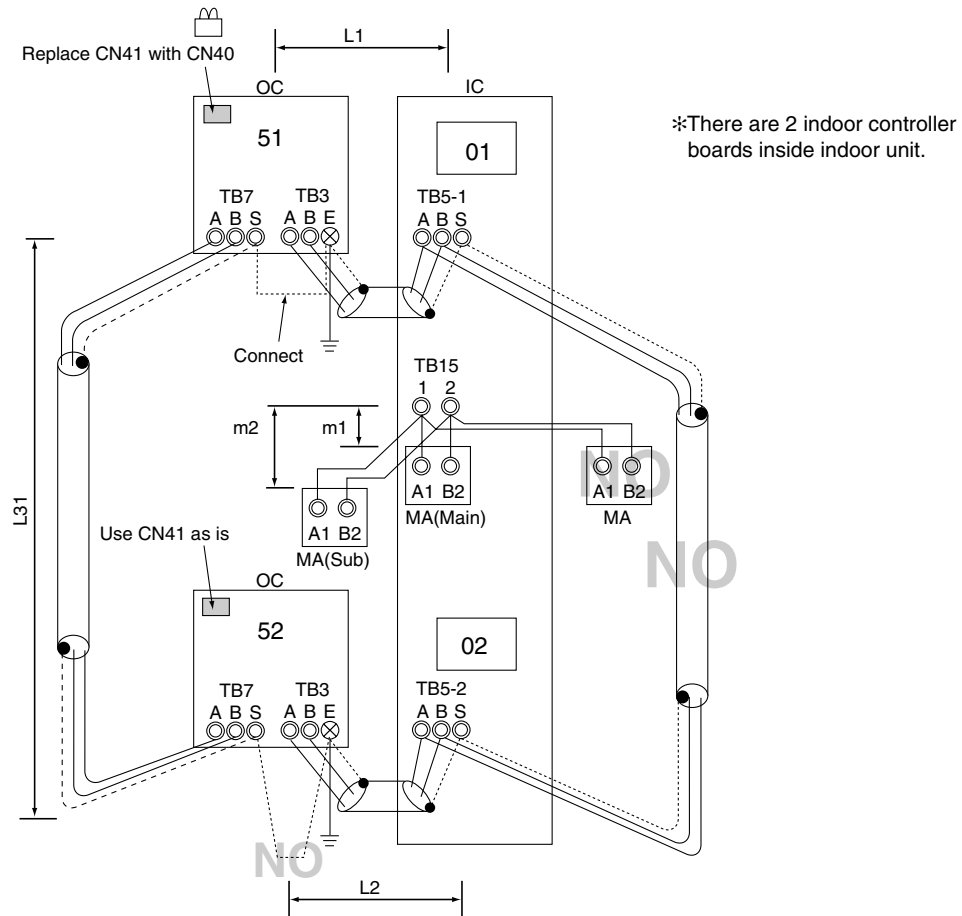

Remarks

1. Use sequential numbers to set indoor unit address.
2. Do not connect TB5s' of the indoor units that are connected to different outdoor units with each other.
3. Replace CN41 with CN40 on only one outdoor unit.
4. Ground only one of the outdoor units' S terminal of TB7 (centralized control transmission terminal).
5. No more than two main and sub controllers can be connected to the indoor unit in the same group.
Disconnect the MA remote control wire from TB15 if using more than 2 remote controllers.
6. The outdoor unit cannot be connected to indoor units other than the PFD-type ones.

Maximum Allowable Length

- <a. Indoor/outdoor transmission line >
Same as (2).
- <b. Transmission line for centralized control >
Same as (2).
- <c. MA remote controller wiring >
Maximum allowable length (0.3 ~ 1.25mm²)
 $m1 + m2 \leq 200m$

Wiring and Address Setting

<a. Indoor/Outdoor Transmission Line >

Same as (2).

<b. Transmission Line for Centralized Control >

Same as (2).

<c. MA Remote Controller Wiring >

[When using 2 remote controllers]

When using two remote controllers, connect terminals 1 and 2 of TB15 on the indoor unit to terminal board of MA controller(option).

*: Set the connected MA remote controller (option) as sub controller (Refer to manual that came with MA remote controller.)

<d. Switch Setting >

Set the address as follows.

Steps	Unit or Controller		Address Setting Range	Setting Procedures	Remarks	Factory Setting
1	Indoor Unit	Main Unit	IC 01 ~ 49	Set the address for the controller at the top of the indoor unit. Start with "01" then use sequential odd numbers (i.e.01, 03, 05). Add 1 to the address assigned to the main unit in the same room.		00
		Sub Unit	IC 02 ~ 50			
2	Outdoor Unit		OC 51 ~ 100	Add 50 to the address assigned to the indoor unit within the same refrigerant system.		00
3	MA remote controller	Main Controller	MA n/a	-		Main
		Sub Controller	MA Sub controller	Use dipswitch to set the controller as sub controller.		

① System Using MA Remote Controller

(4) When grouping 2 indoor units (20HP systems) with MA remote controller

Control Wiring Diagram

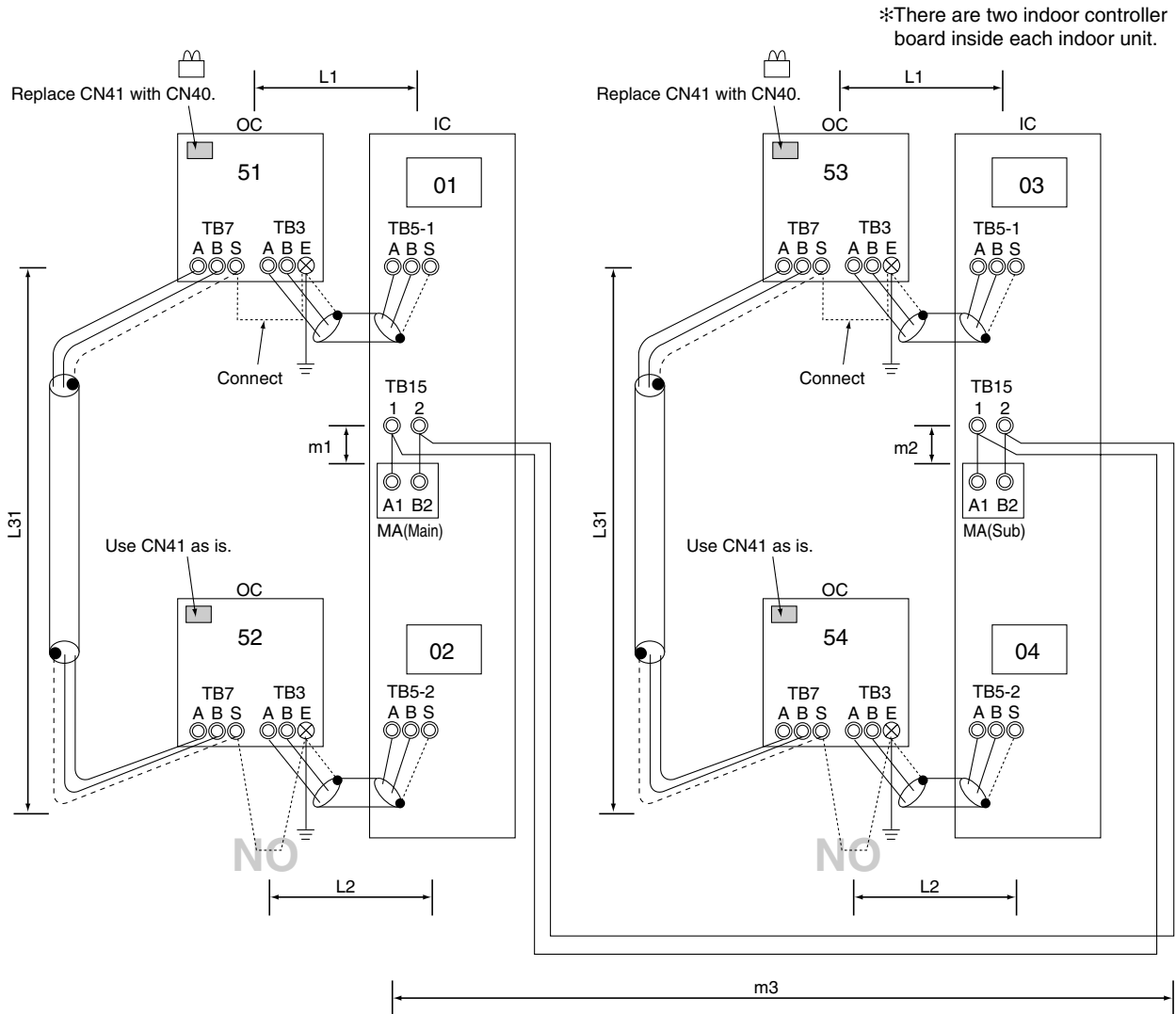

Remarks

1. Use sequential numbers to set indoor unit address.
2. Do not connect TB5s' of the indoor units that are connected to different outdoor units with each other.
3. Replace CN41 with CN40 on only one outdoor unit.
4. Ground only one of the outdoor units' S terminal of TB7 (centralized control transmission terminal).
5. No more than two main and sub controllers can be connected to the indoor unit in the same group. Disconnect the MA remote control wire from TB15 if using more than 2 remote controllers.
6. The outdoor unit cannot be connected to indoor units other than the PFD-type ones.

Maximum Allowable Length

- <a. Indoor/outdoor transmission line >
Same as (2).
- <b. Transmission line for centralized control >
Same as (2).
- <c. MA remote controller wiring >
Maximum allowable length (0.3 ~ 1.25mm²)
 $m1 + m2 + m3 \leq 200m$

Wiring and Address Setting

<a. Indoor/Outdoor transmission line >

Same as (2).

<b. Transmission Line for Centralized Control >

Same as (2).

<c. MA remote controller line >

* When grouping units that use different refrigerants, set MA remote controller of one of the indoor units as sub controller.

[When grouping indoor units]

When grouping indoor units, connect 1 and 2 terminals of both IC terminal boards (TB15) with each other (non-polar 2 line).

* Set MA remote controller of one of the indoor units as sub controller.

<d. Switch Setting >

Set the address as follows.

Steps	Unit or Controller			Address Setting Range	Setting Procedures	Remarks	Factory Setting
1	Indoor Unit	Main Unit	IC	01 ~ 49	Set the address for the controller at the top of the indoor unit. Start with "01" then use sequential odd numbers (i.e.01, 03, 05). Add 1 to the address assigned to the main unit in the same room.		00
		Sub Unit	IC	02 ~ 50			
2	Outdoor Unit		OC	51 ~ 100	Add 50 to the address assigned to the indoor unit within the same refrigerant system.		00
3	MA remote controller	Main Controller	MA	n/a	-		Main
		Sub Controller	MA	Sub controller	Use dipswitch to set the controller as sub controller.		

- ① System Using MA Remote Controller
 (5) When grouping multiple indoor units (combination of 10HP, 20HP systems)

Control Wiring Diagram

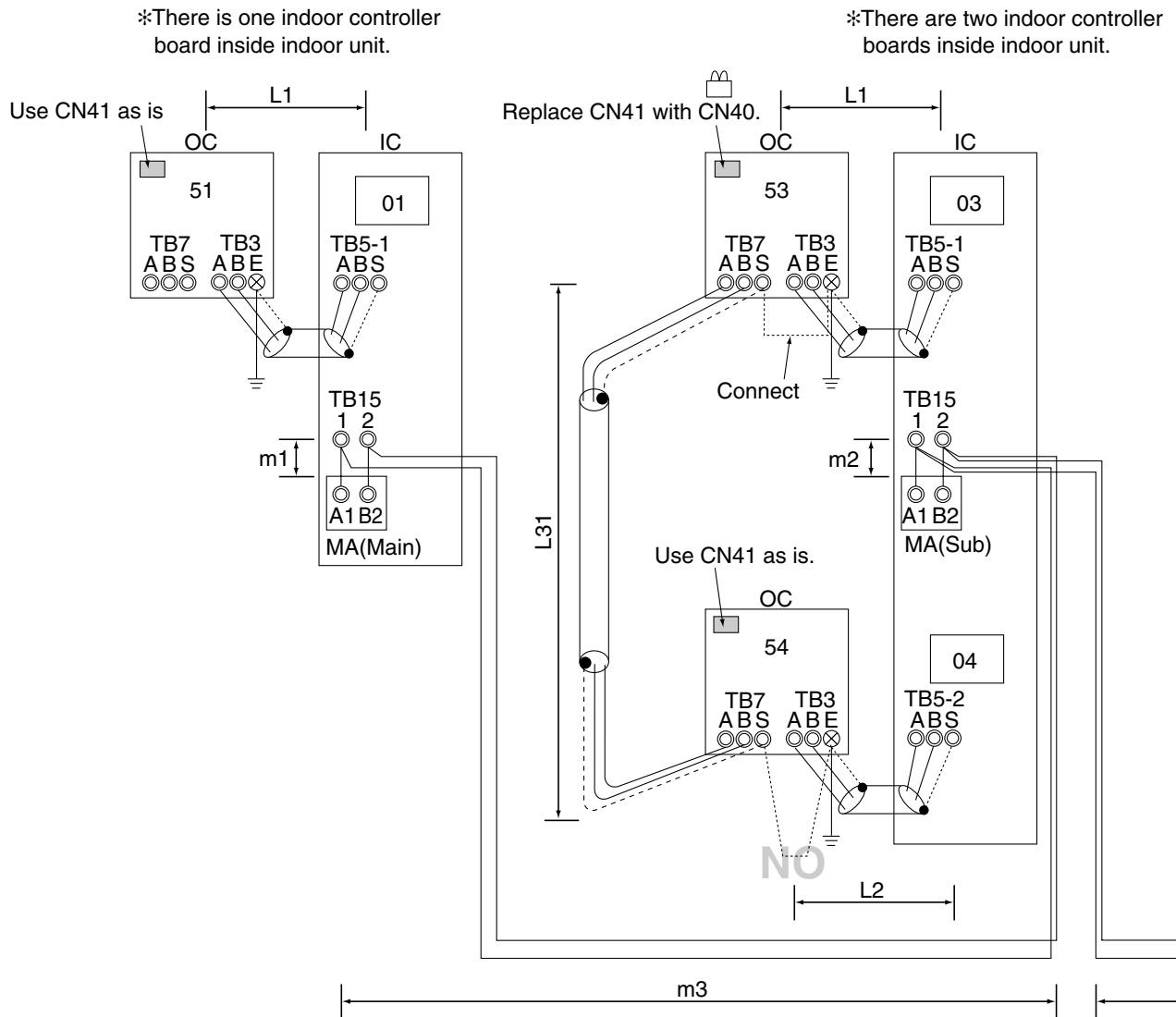

Remarks	Maximum Allowable Length
<ol style="list-style-type: none"> Use odd numbers to set 10HP indoor unit address. When setting unit address for 20HP indoor unit, use odd numbers for the top controllers and even numbers for the bottom controllers (main controller+1). Replace CN41 (power supply switch connector) with CN40 on only one 20HP outdoor unit. Ground the S terminal of TB7 (centralized control transmission terminal board) of only one of the 20HP outdoor units. No more than two main and sub controllers can be connected to the indoor unit in the same group. Disconnect the MA remote control wire from TB15 if using more than 2 remote controllers. The outdoor unit cannot be connected to indoor units other than the PFD-type ones. 	<ul style="list-style-type: none"> <a. Indoor/Outdoor Transmission Line > Same as (2). <b. Transmission Line for Centralized Control > Same as (2). <c. MA Remote Controller Line > Total Length (0.3 ~ 1.25mm²) $m1 + m2 + m3 + m4 + m5 \leq 200m$

Control Wiring Diagram

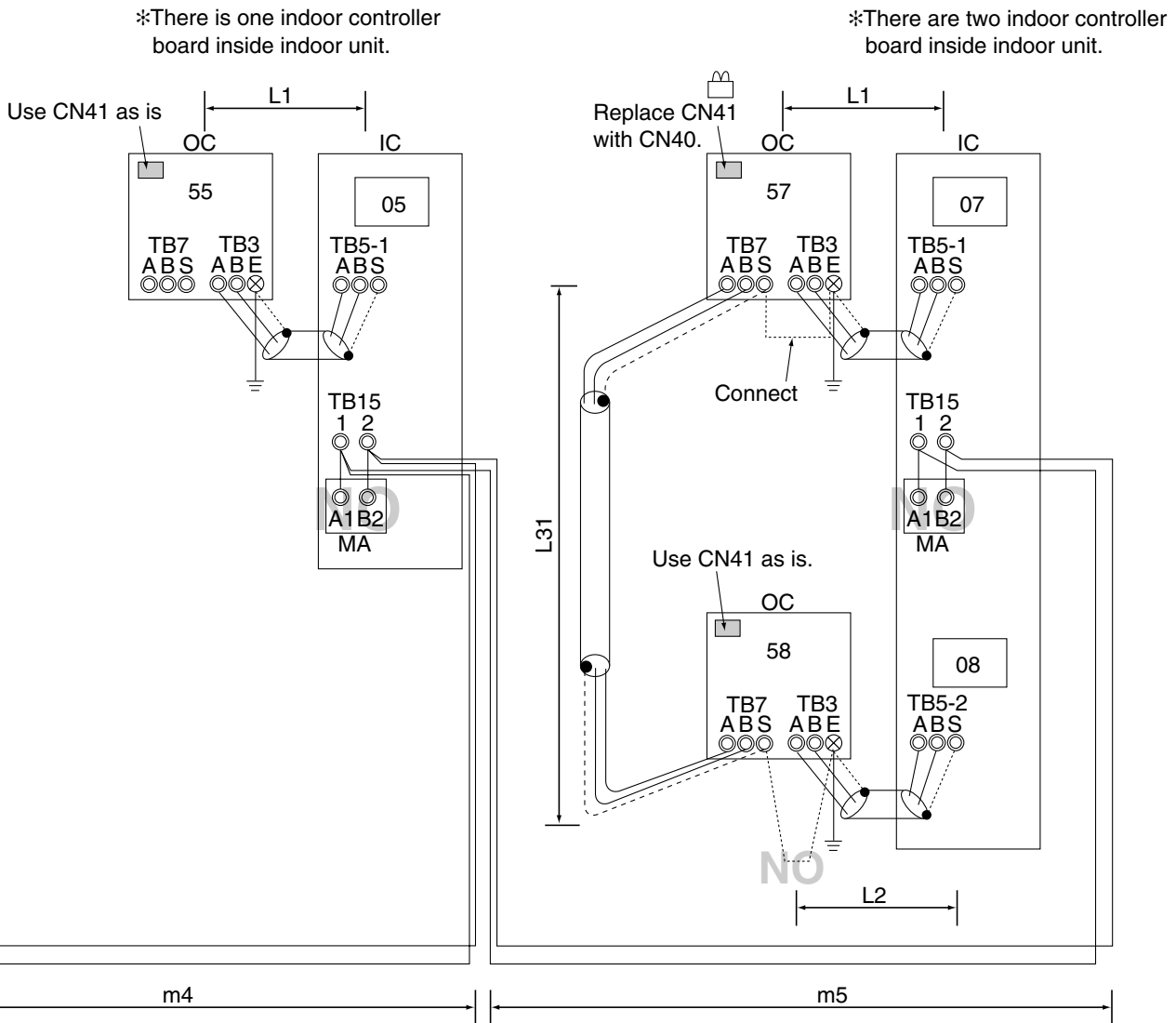

Steps	Unit or Controller		Address Setting Range	Setting Procedures	Remarks	Factory Setting
1	Indoor Unit	Main Unit (10HP, 20HP)	IC 01 ~ 49	Set the address for the controller at the top of the indoor unit. Start with "01" then use sequential odd numbers (i.e.01, 03, 05).		00
		Sub Unit (20HP)	IC 02 ~ 50	Add 1 to the address assigned to the main unit in the same room.		
2	Outdoor Unit		OC 51 ~ 100	Add 50 to the address assigned to the indoor unit within the same refrigerant system.		00
3	MA remote controller	Main Controller	MA n/a	-		Main
		Sub Controller	MA Sub controller	Use dipswitch to set the controller as sub controller.		

- ② System with MA remote controller and G-50A
 (1) System with multiple indoor units (10HP, 20HP)

Control Wiring Diagram

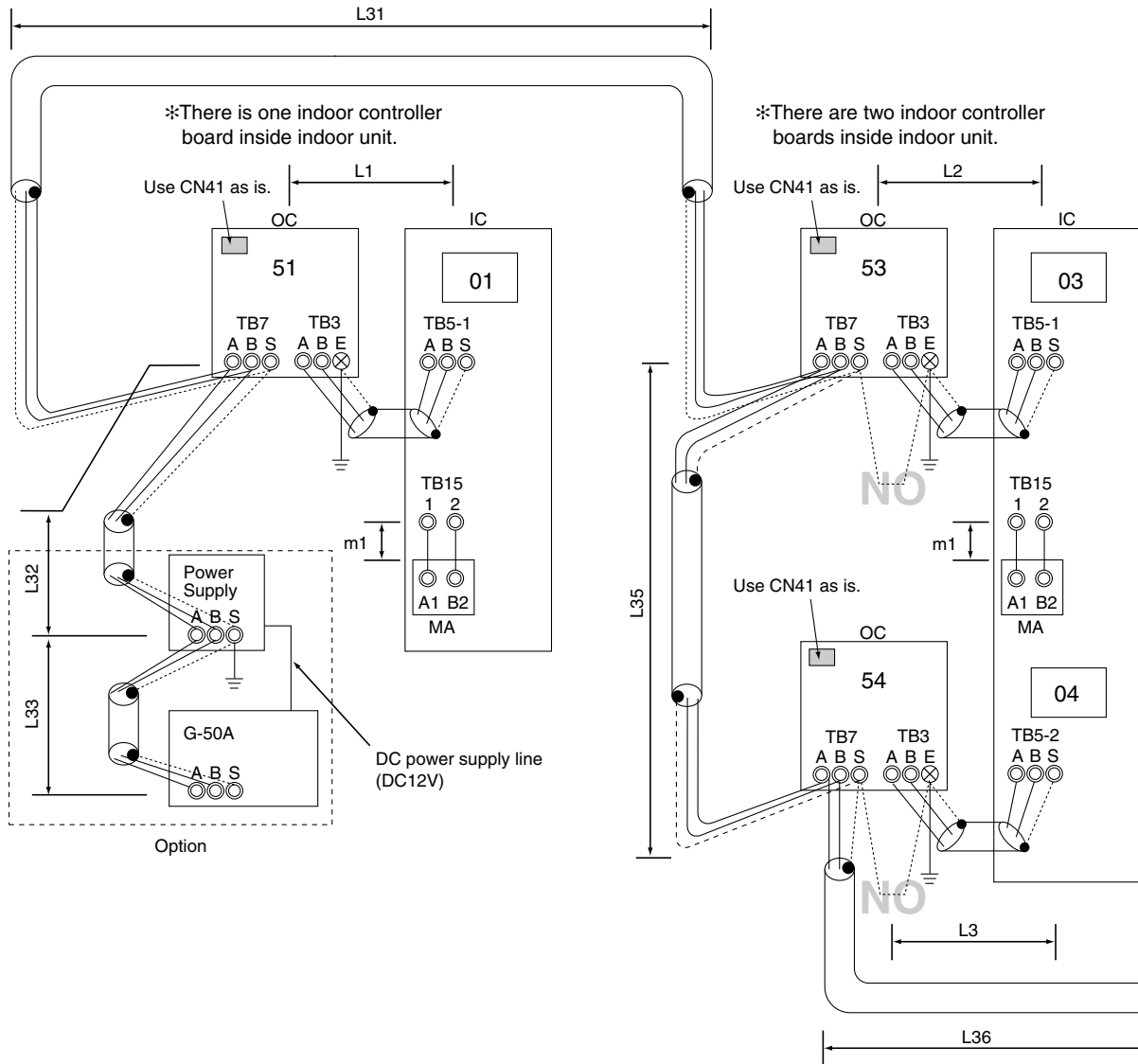

Remarks

1. Be sure to use odd numbers to set the address for indoor units (10HP).
2. To set the indoor unit address for 20HP, use odd numbers for the top controllers and use even numbers for the bottom controllers (Main controller plus 1).
3. Use the power supply switch connector (CN41) on the outdoor unit as is.
4. It is not necessary to ground the S terminal of transmission line terminal board for centralized controller on the outdoor unit.
5. No more than two main/sub remote controllers can be connected to the indoor unit in the same group. When more than two remote controllers are present in the system, disconnect MA remote controller from TB15 in the indoor unit.
6. Put both types of the addresses for P500-type indoor units in the same group when setting groups for indoor units with a remote controller.
7. The outdoor unit cannot be connected to indoor units other than the PFD-type ones.

Maximum Allowable Length

- <a. Indoor/Outdoor transmission line>
 $L1, L2, L3, L4, L5, L6 \leq 200\text{m}$
- <b. Transmission Line for Centralized Control >
 $L31 + L32 + L33 + L35 + L36 + L37 + L38 + L6 \leq 500\text{m}$
 $L1 + L31 + L35 + L36 + L37 + L38 + L6 \leq 500\text{m}$
- <c. MA Remote Controller Line >
 Total Length (0.3 ~ 1.25mm²)
 $m1 \leq 200\text{m}$

Control Wiring Diagram

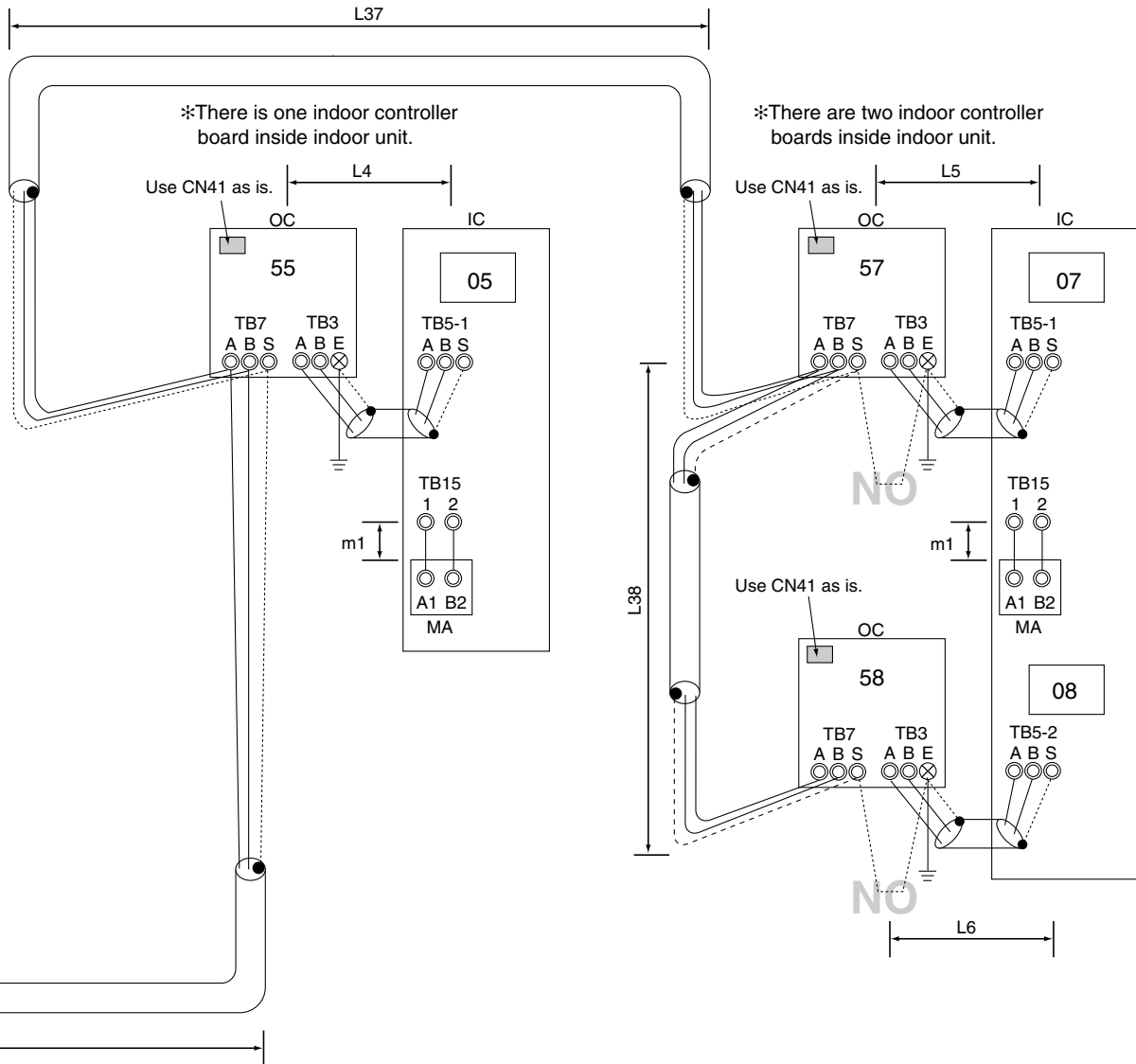

Steps	Unit or Controller		Address Setting Range	Setting Procedures	Remarks	Factory Setting
1	Indoor Unit	Main Unit (10HP, 20HP)	IC 01 ~ 49	Set the address for the controller at the top of the indoor unit. Start with "01" then use sequential odd numbers (i.e.01, 03, 05).		00
		Sub Unit (20HP)	IC 02 ~ 50	Add 1 to the address assigned to the main unit in the same room.		
2	Outdoor Unit		OC 51 ~ 100	Add 50 to the address assigned to the indoor unit within the same refrigerant system.		00
3	MA remote controller	Main Controller	MA n/a	-		Main
		Sub Controller	MA Sub controller	Use dipswitch to set the controller as sub controller.		

3 Restrictions on Refrigerant Pipe Length

There are two types of refrigerant circuits: one with one refrigerant circuit and another with two refrigerant circuits. The former consists of refrigerant piping from one outdoor unit connected to an indoor unit (P250), and the latter consists of refrigerant piping from two outdoor units connected to an indoor unit (P500). Use flange connection for gas pipes, and use flare connection for liquid pipes for both indoor and outdoor units.

⚠ Warning

Exercise caution so that refrigerant R407C does not leak around fire. When exposed to an open flame, refrigerant can produce noxious gases and subject the personnel to gas poisoning. Provide adequate ventilation during welding. Also, check for possible gas leak after the installation of refrigerant piping has been completed.

Do not use refrigerant other than R407C.

- If refrigerant other than R407C is used or if air enters the cycle, the system malfunctions and the pipes may explode.

When using two refrigerant circuits, make sure that gas pipes and liquid pipes do not get cross-connected to each other by accident.

- Doing so will damage the unit.

⚠ Caution

Use refrigerant pipes made of C1220 phosphorus deoxidized copper categorized under H3300 (Copper and Copper Alloy Seamless Pipes and Tubes), a standard set by JIS.

- Keep inner and outer surfaces of the pipes clean and free of contaminants such as sulfur, oxides, dust/dirt, shaving particles, oils, and moisture.
- Contaminants inside the refrigerant piping will deteriorate the refrigerant oil.

Do not use the existing refrigerant piping.

- The old refrigerant and refrigerator oil in the existing piping contain a large amount of chlorine, which may cause the refrigerator oil of the new unit to deteriorate.

Use liquid refrigerant to charge the circuit.

- Charging the system with gas refrigerant will change the composition of the refrigerant in the cylinder and will lead to a drop in performance.

Store the piping to be used during installation indoors and keep both ends of the piping sealed until immediately before blazing. (Keep elbows and other joints wrapped in plastic.)

- If refrigerant is contaminated with dust, dirt, or moisture, refrigerator oil will deteriorate and problems with compressor may result.

Do not use a charging cylinder.

- The use of charging cylinder will change the composition of the refrigerant and lead to power loss.

Do not use a charging cylinder.

- The use of charging cylinder will change the composition of the refrigerant and lead to power loss.

[1] Refrigerant Piping

	< P250 Type >	< P500 Type >
Sample Unit Connection		
Maximum Pipe Length (L)	Total length: 120m Equivalent length: 150m	Total length: 120m Equivalent length: 150m
Maximum Height Difference Between Indoor and outdoor units (H)	Under 50m (Under 40m if the outdoor unit is installed below the indoor unit. Under 15m if the outdoor temperature is under 10°C.)	Under 50m (Under 40m if the outdoor unit is installed below the indoor unit. Under 15m if the outdoor temperature is under 10°C.)
■ Selecting Refrigerant Pipes	Gas pipe: ϕ 28.58 Liquid pipe: ϕ 12.7	Gas pipe: ϕ 28.58 \times 2 Liquid pipe: ϕ 12.7 \times 2

II . Components of the Unit

I Internal Structure

< PUD-P250YMF-C >

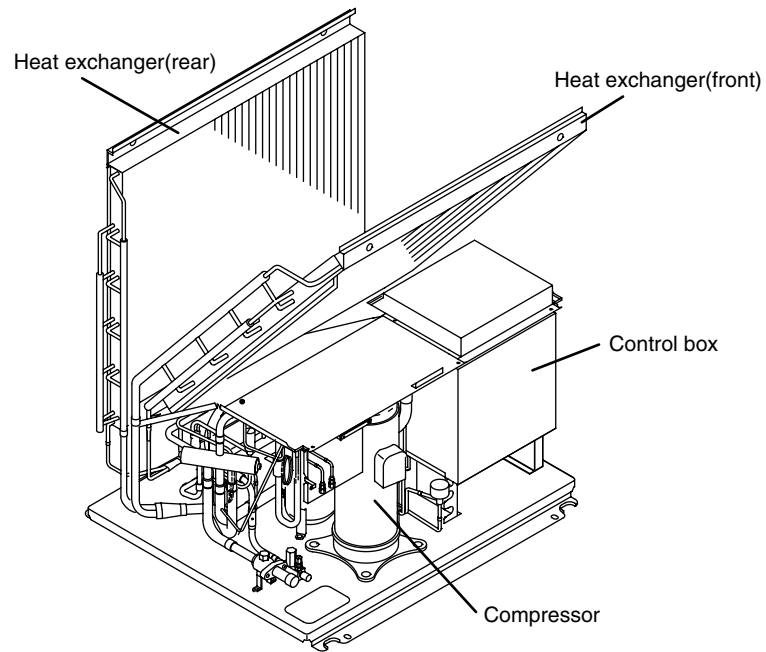
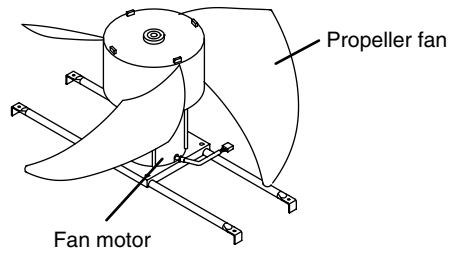

PUD-YMF-C

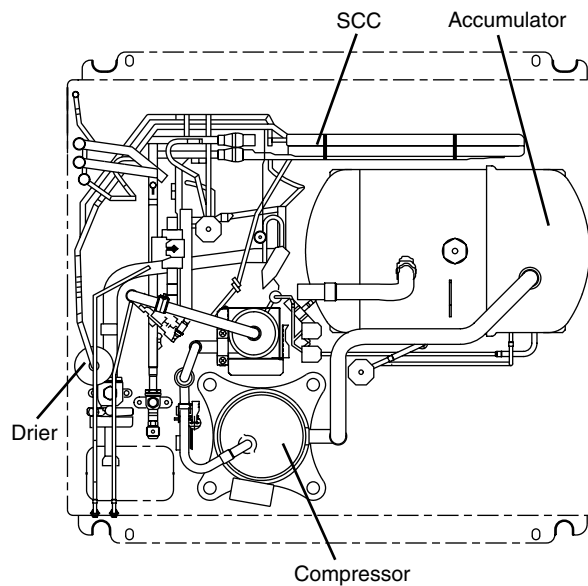

< PFD-P250VM-A >

(1) Front

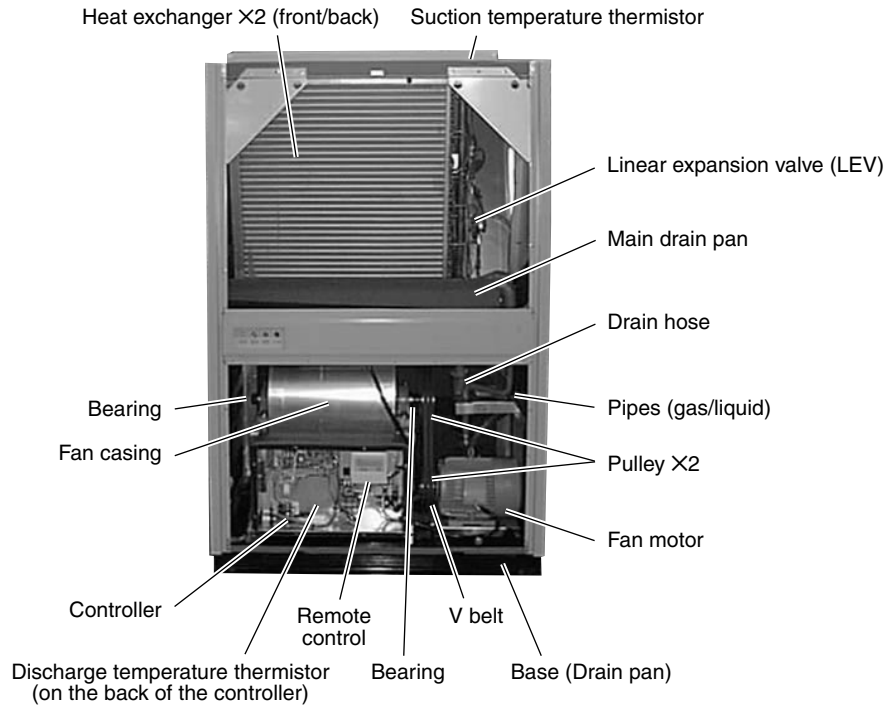

<Location of drain pan overflow detection float switch>

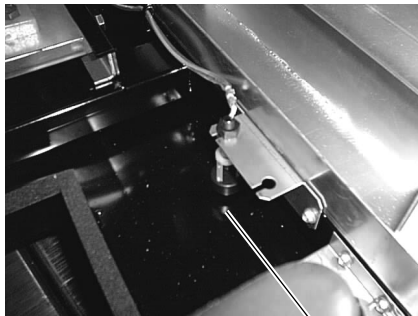

Float switch

<Location of main drain pan overflow detection float switch>

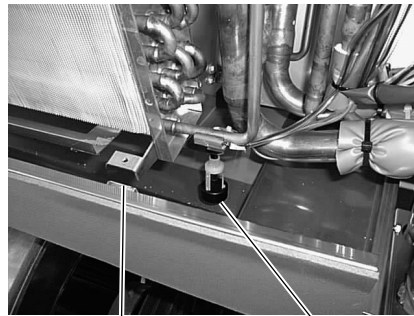

Drain pan fixation point Float switch

(2) Back

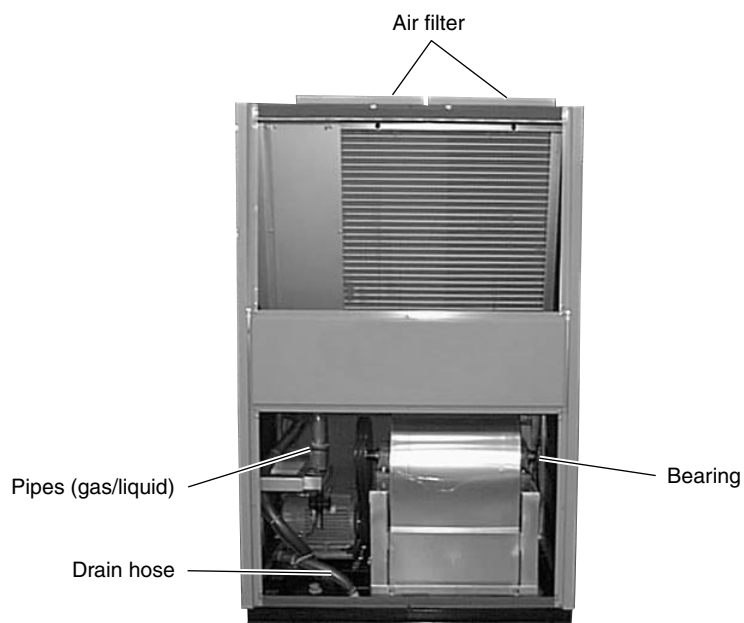

< PFD-P500VM-A >

(1) Front

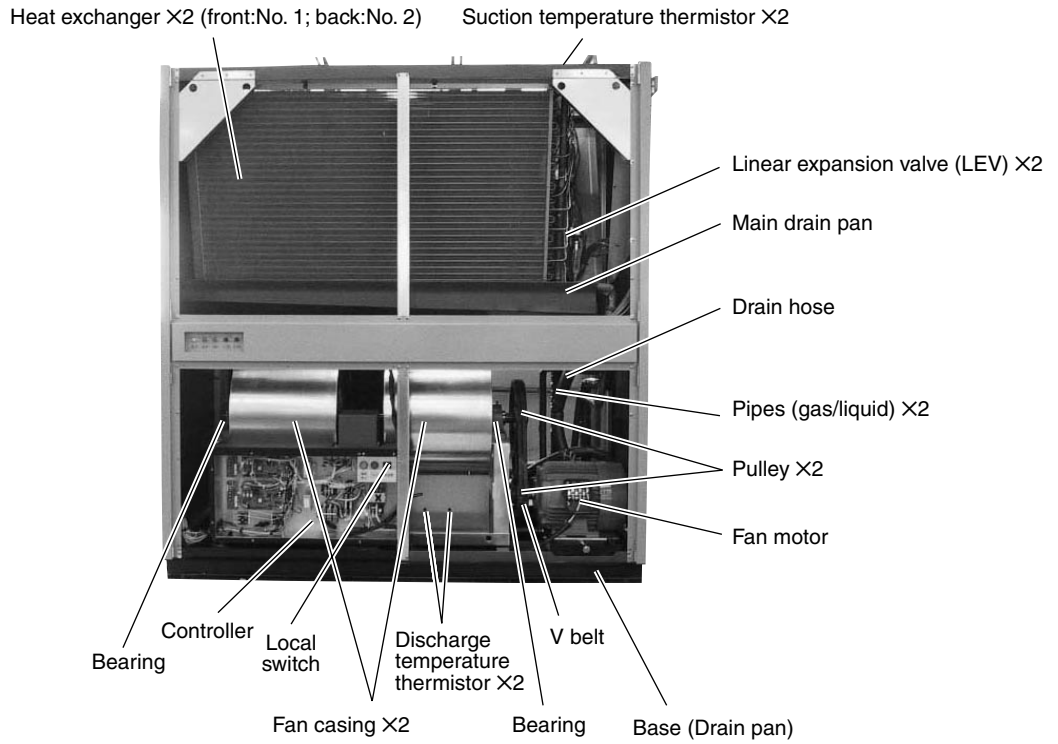

<Location of drain pan overflow detection float switch>

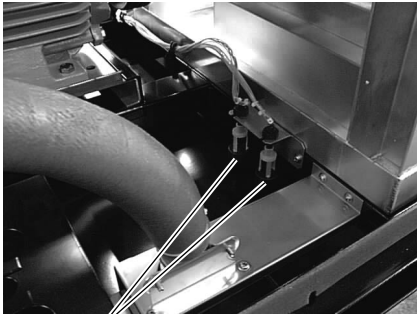

Float switch X2

<Location of main drain pan overflow detection float switch>

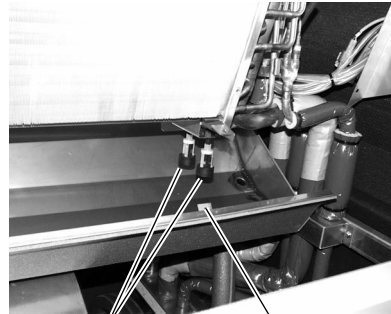

Float switch X2 Drain pan fixation point

(2) Back

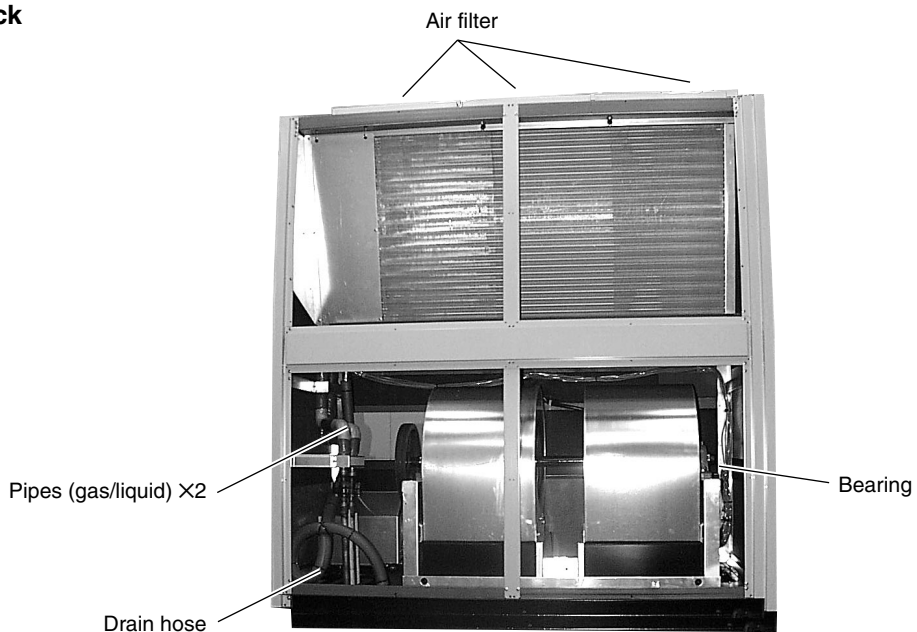

2 Control Box

< PUD-P250YMF-C >

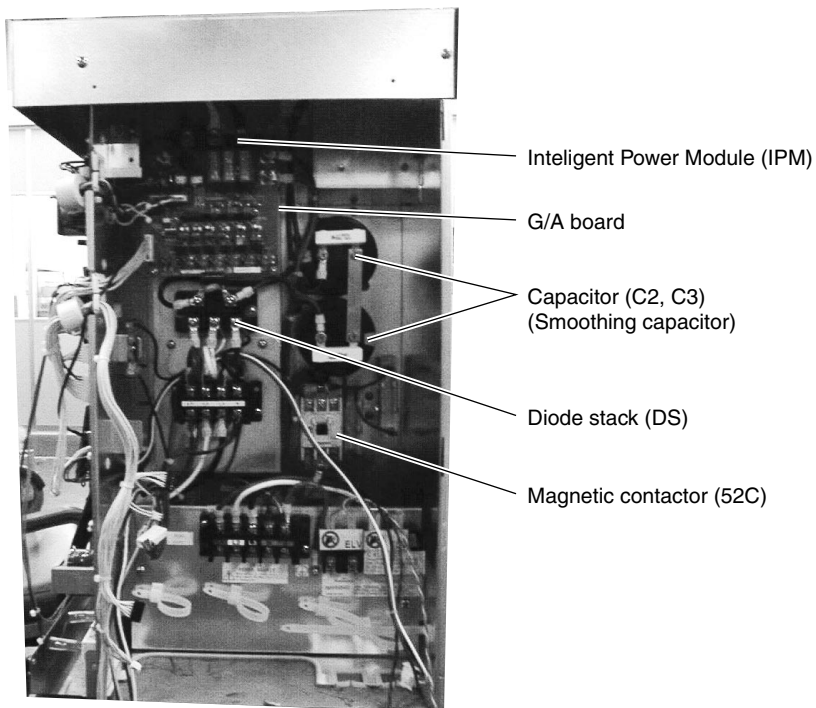
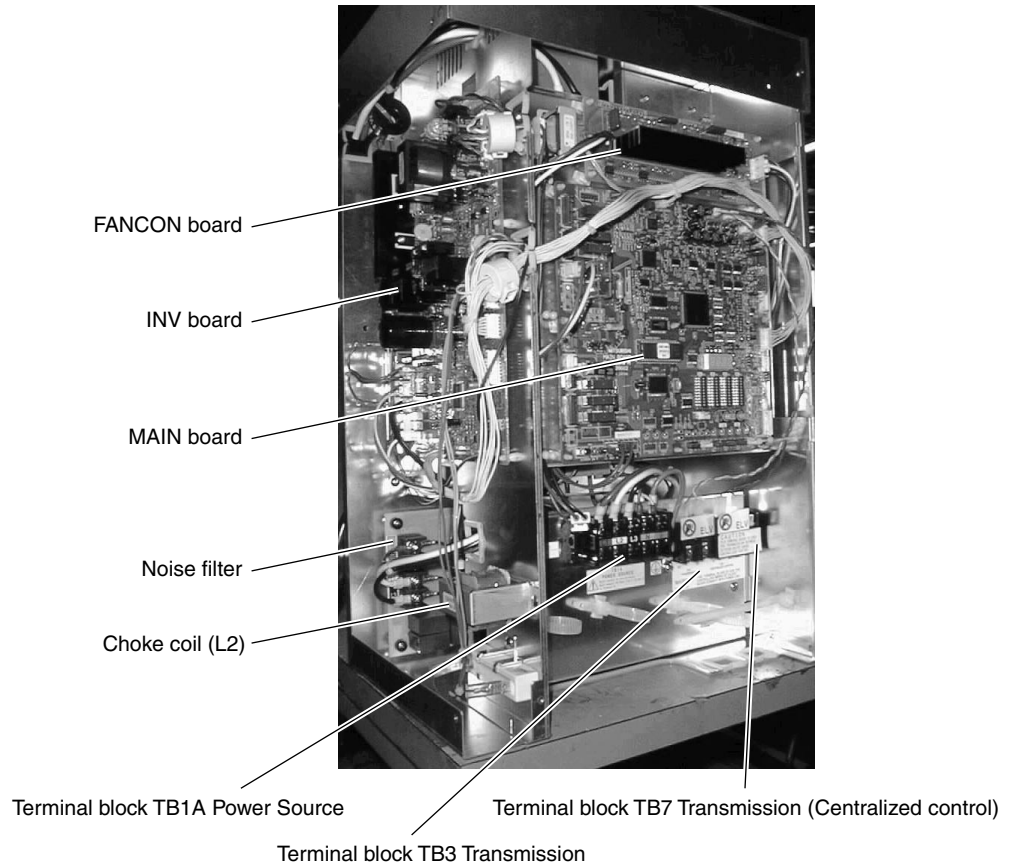

< PFD-P250VM-A >

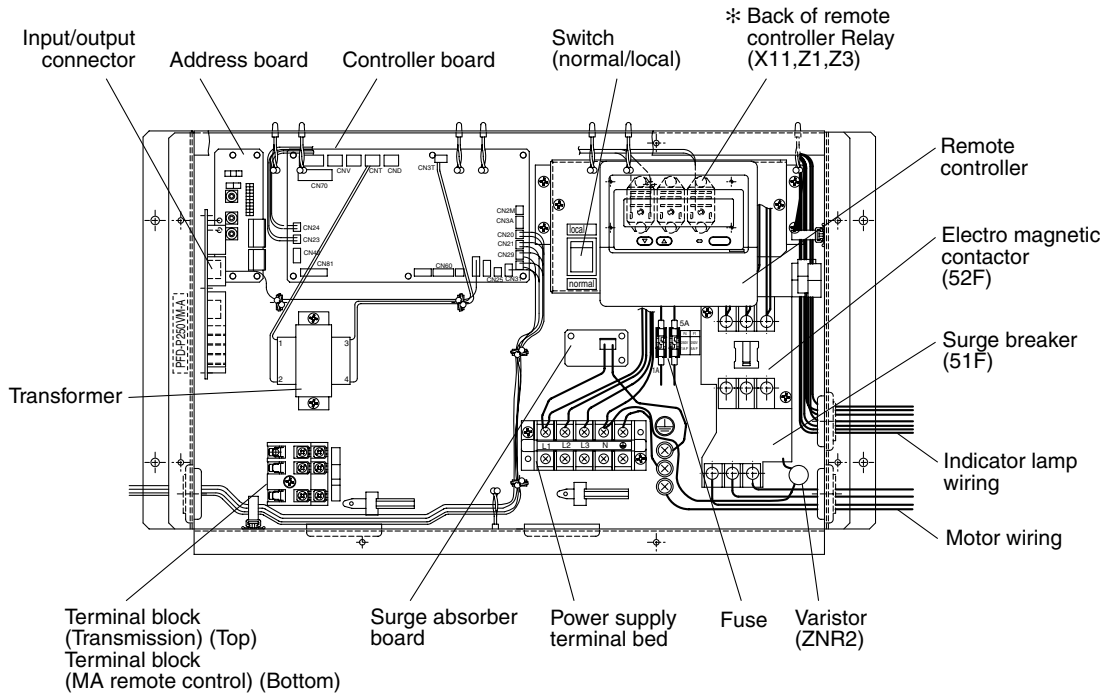

< PFD-P500VM-A >

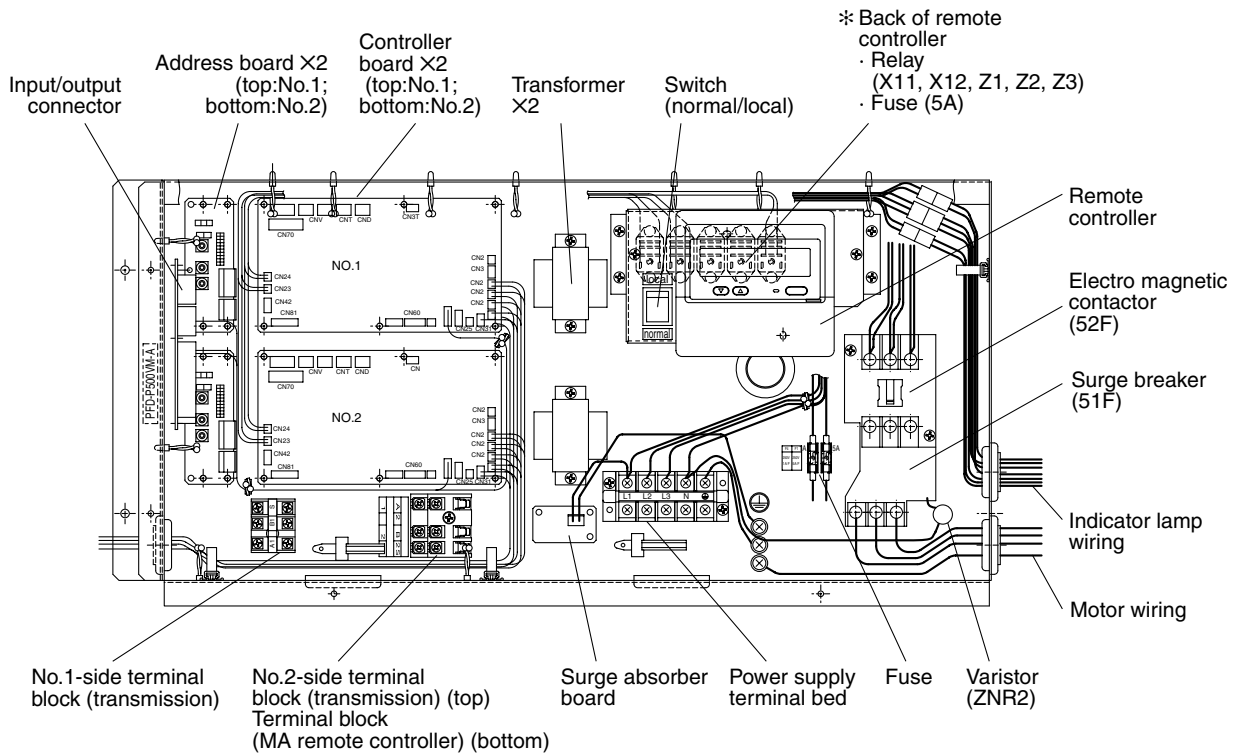

3 Main Board

< PUD-P250YMF-C >

Main Board

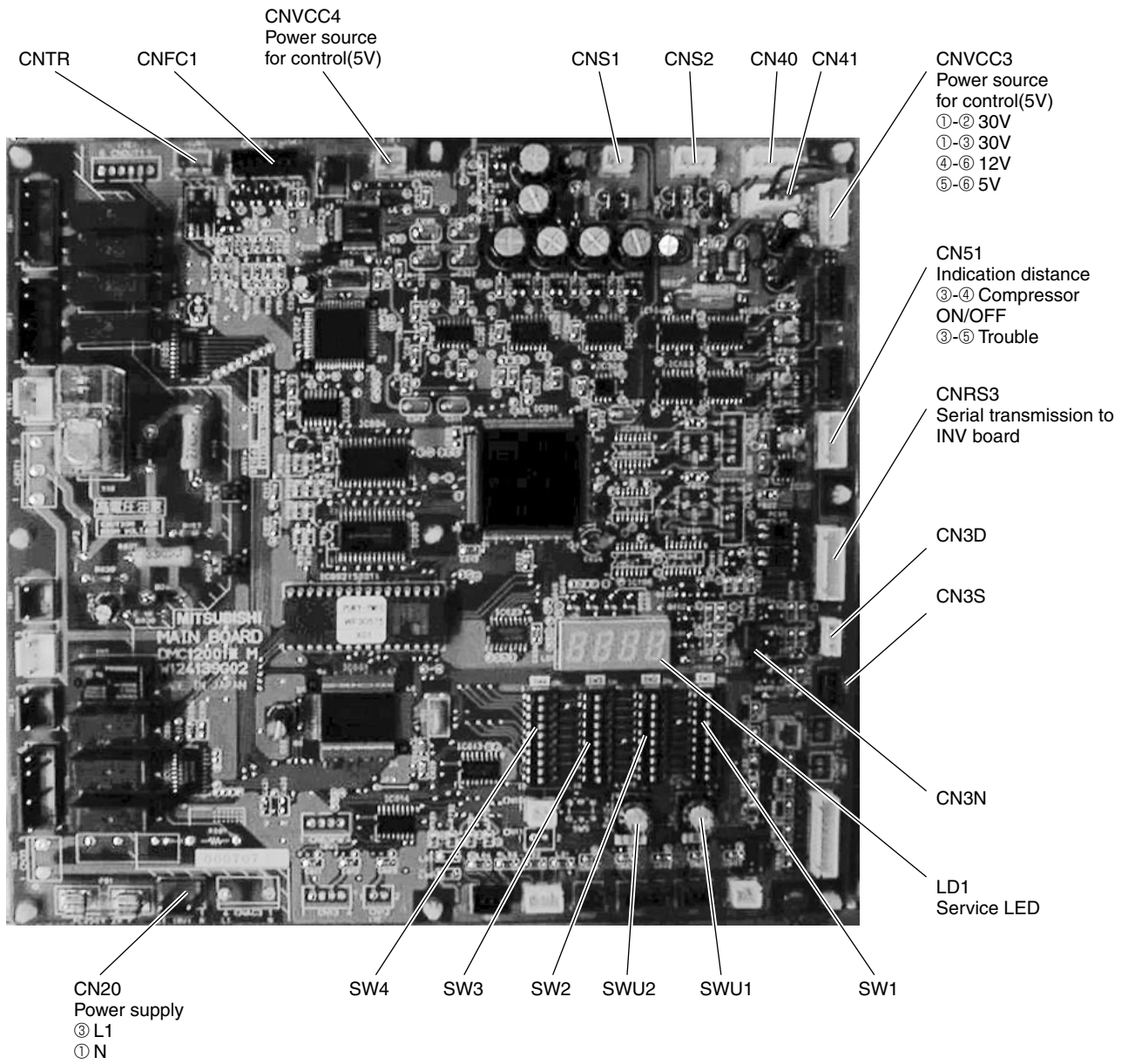

INV Board

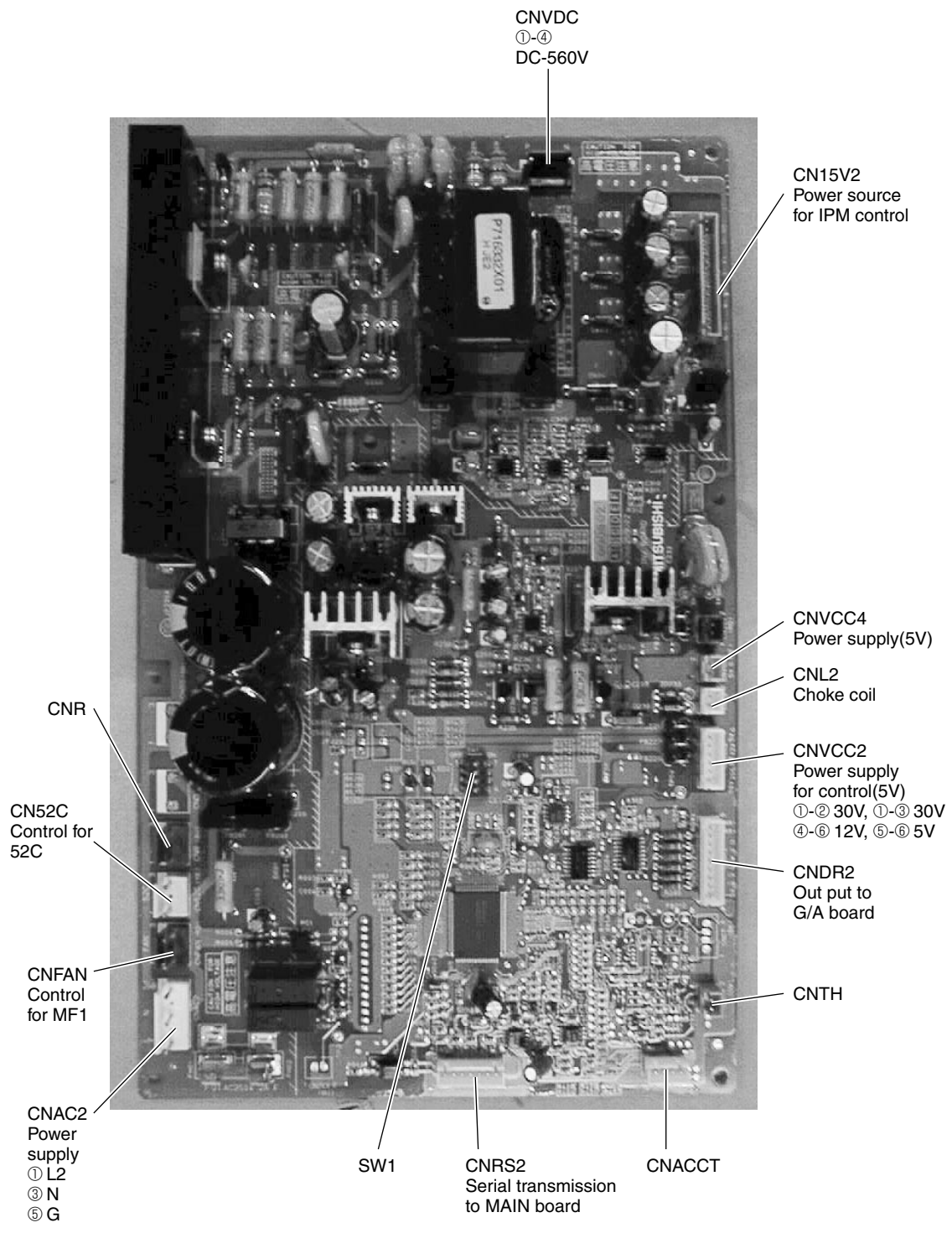

CNVDC
①-④
DC-560V

CN15V2
Power source
for IPM control

CNVCC4
Power supply(5V)

CNL2
Choke coil

CNVCC2
Power supply
for control(5V)
①-② 30V, ①-③ 30V
④-⑥ 12V, ⑤-⑥ 5V

CNDR2
Out put to
G/A board

CNTH

CNR

CN52C
Control for
52C

CNFAN
Control
for MF1

CNAC2
Power
supply
① L2
③ N
⑤ G

SW1

CNRS2
Serial transmission
to MAIN board

CNACCT

FANCON Board

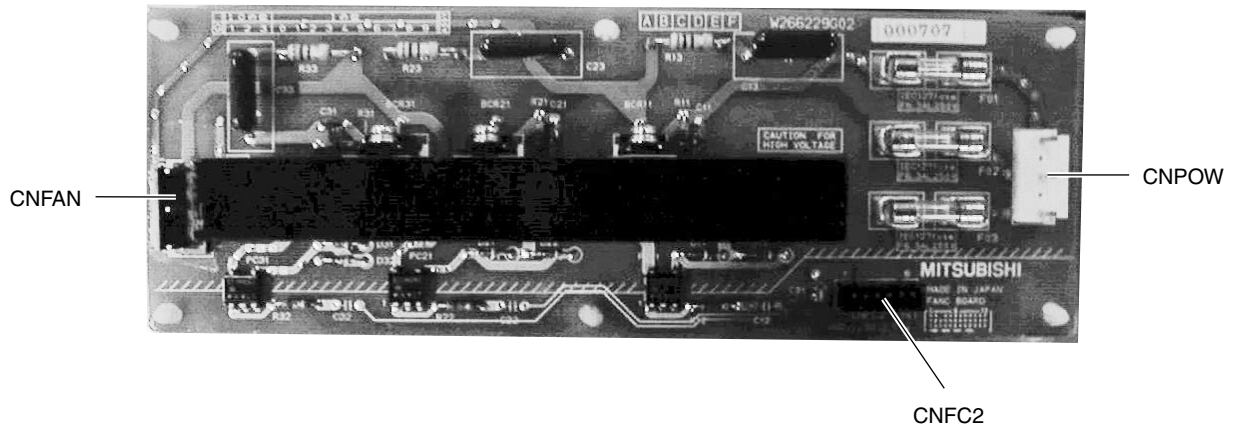

G/A Board

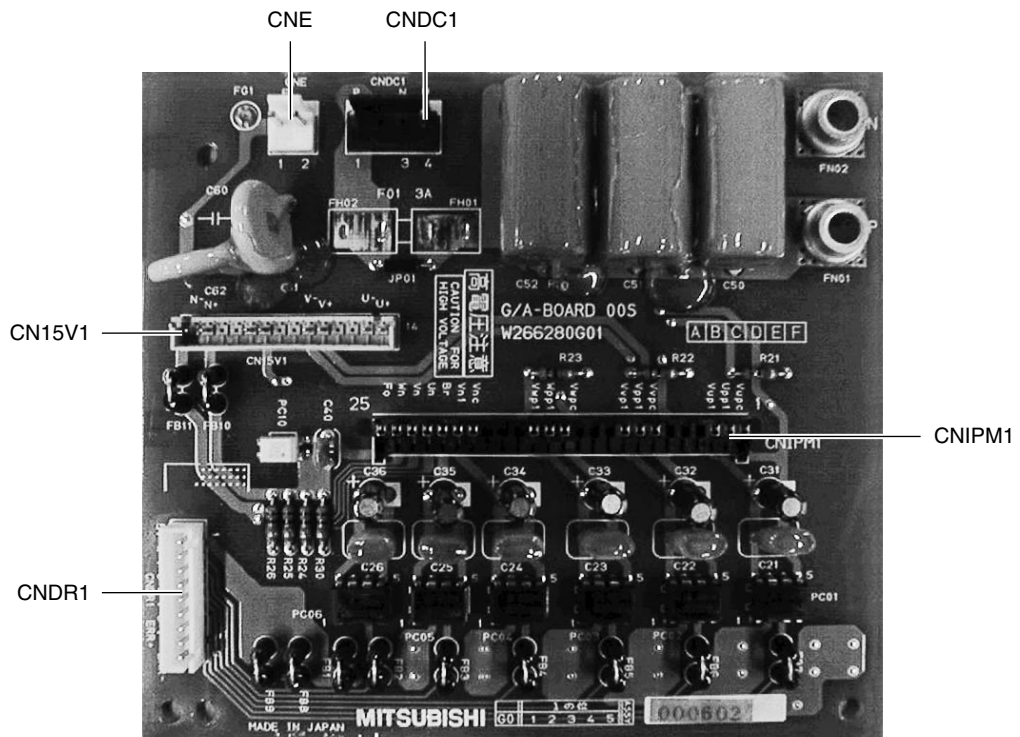

< PFD-P250,500VM-A >

Indoor Control Board

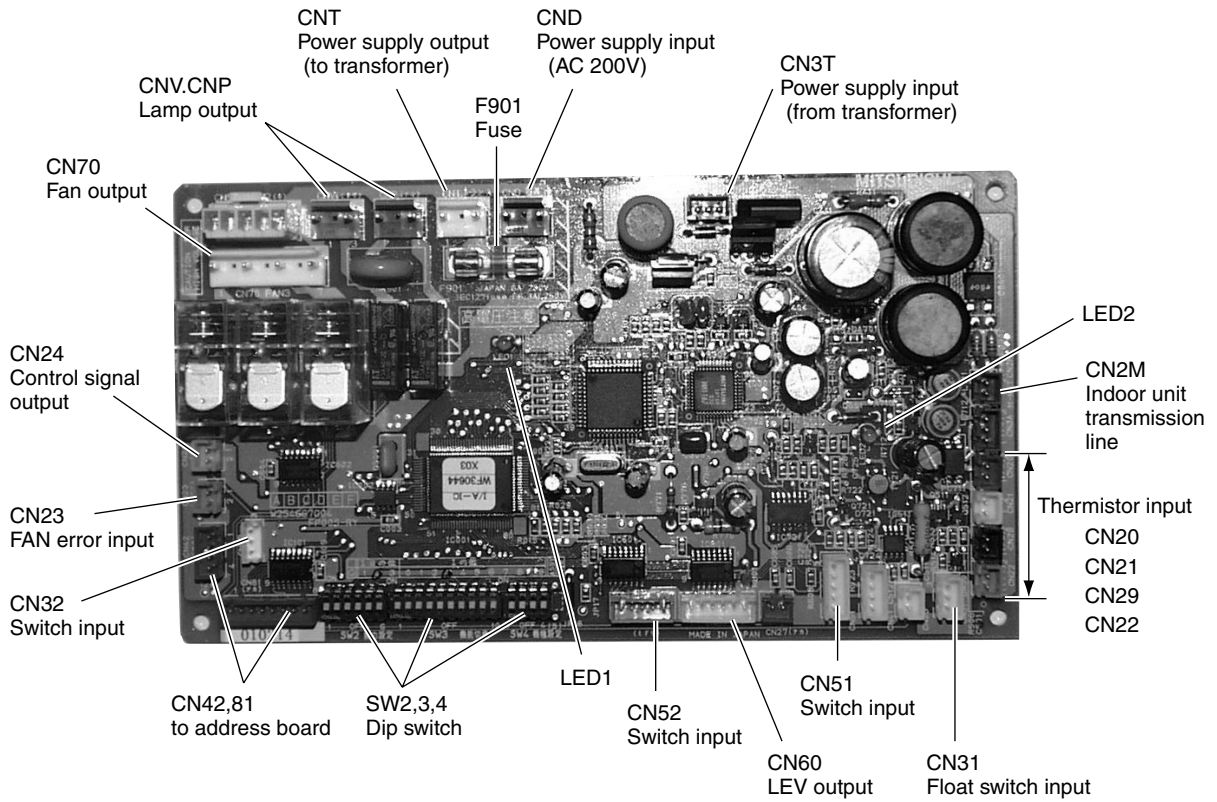

Indoor Address Board

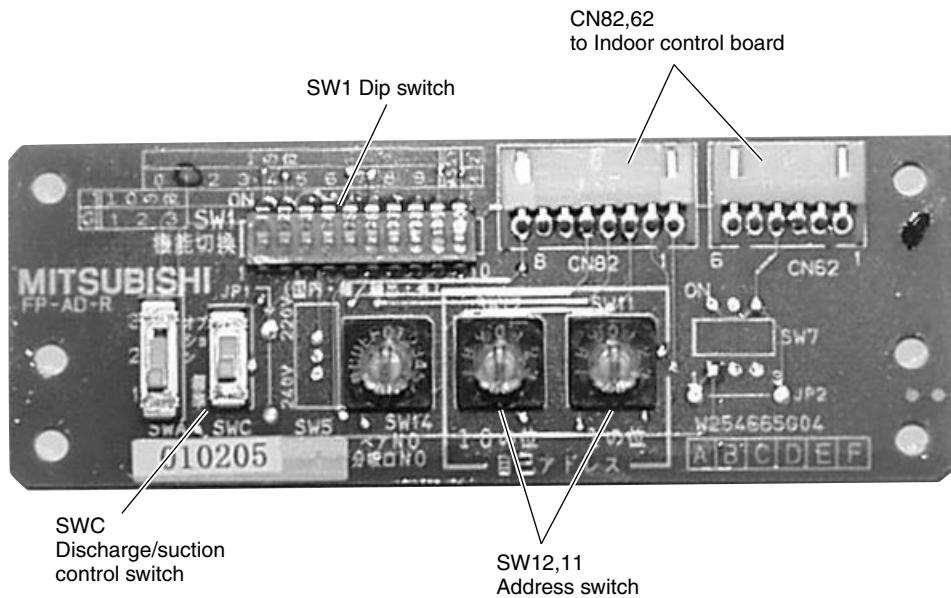

External Input/Output Circuit Board

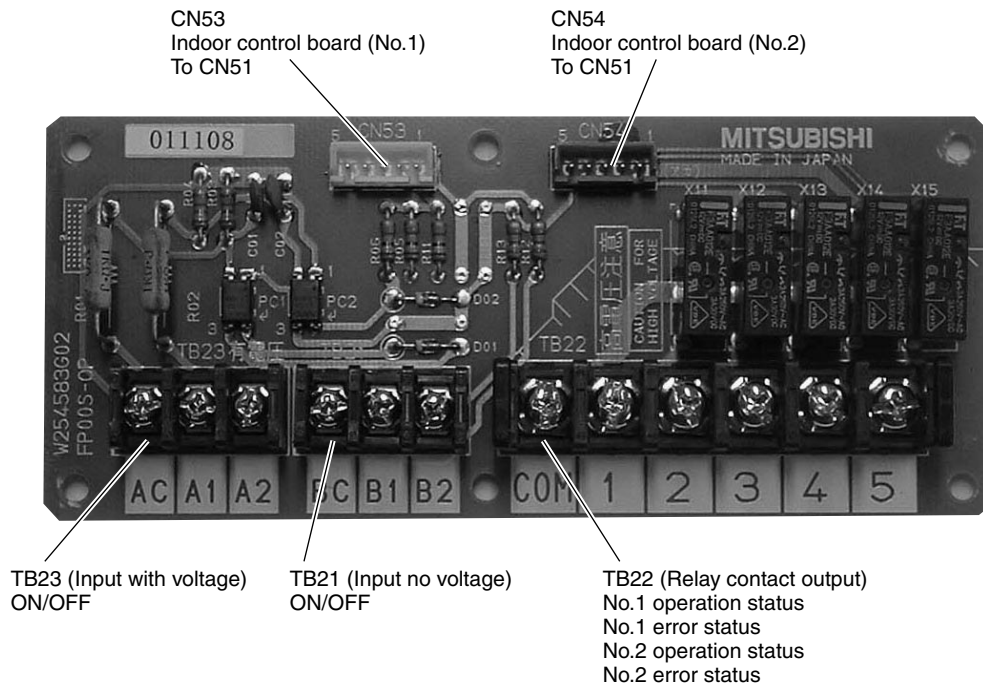

III. Electrical Wiring Diagrams

I Outdoor Unit

(1) PUD-P250YMF-C

<Symbol explanation>

Symbol	Name
DCL	DC reactor (Power factor improvement)
ACCTU.W	Current Sensor
ZNR4	Variistor
52C	Magnetic contactor (Inverter main circuit)
MF1	Fan motor(Radiator panel)
2/54	4-way valve
SV1, SV2	Solenoid valve(Discharge-suction bypass)
SV3	Solenoid valve (Heat exchanger capacity control)
LEV1	Electronic expansion valve (Sub-cool coil bypass)
SLEV	Electronic expansion valve(Oil return)
63HS	High pressure sensor
63LS	Low pressure sensor
L2	Choke coil(transmission)
IPM	Intelligent power module
TH1	Thermistor Discharge pipe temp. detect
TH2	Saturation evapo. temp. detect
TH5	Pipe temp. detect
TH6	OA temp. detect
TH7	liquid outlet temp. detect at Sub-cool coil
TH8	bypass outlet temp. detect at Sub-cool coil
TH9	High pressure liquid temp.
TH10	Compressor shell temp.
THHS	Radiator panel temp. detect
X1-10	Aux. relay
FBI-4	Ferrite core
⊕	Earth terminal

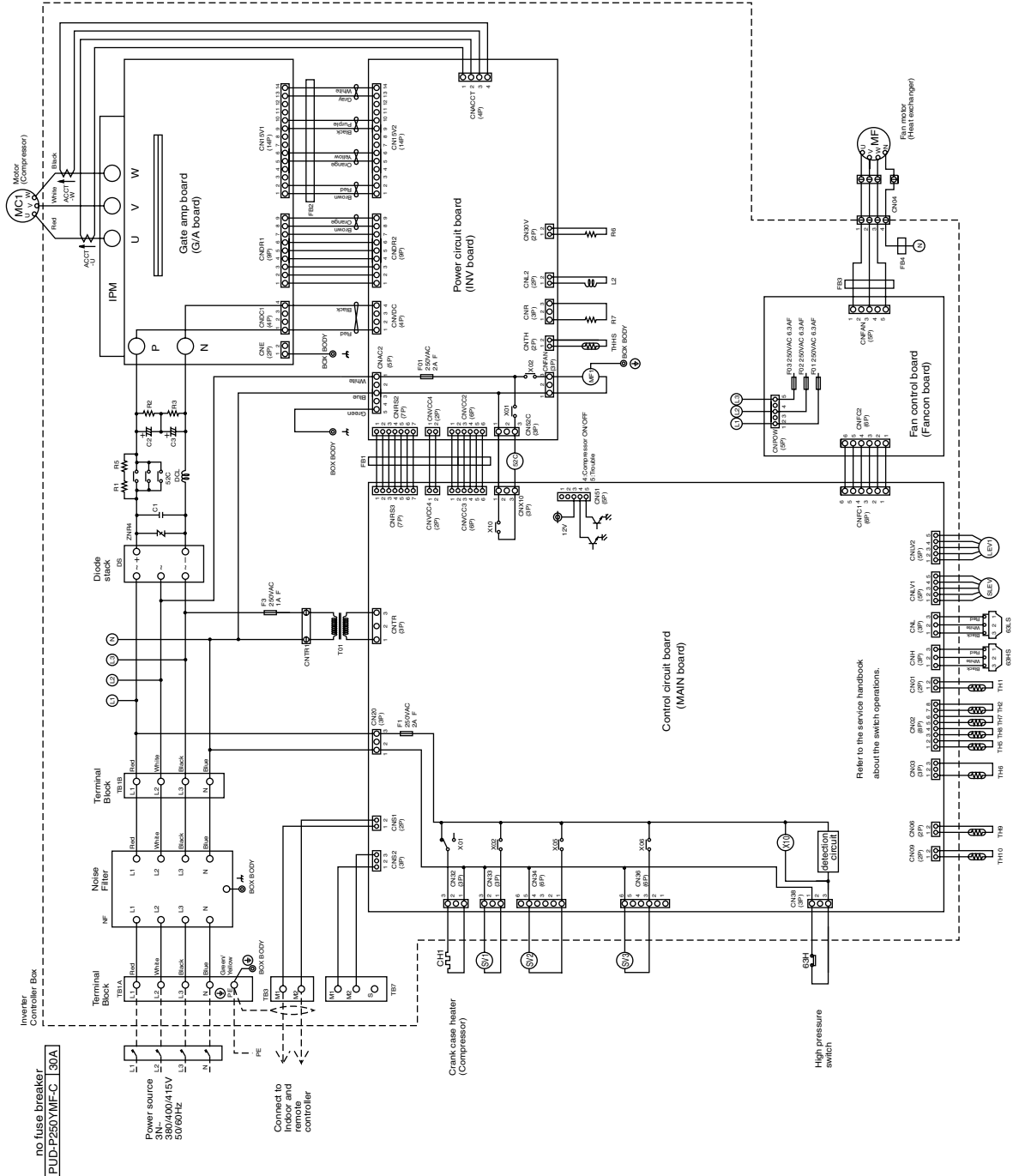

2 Indoor Unit

(1) PFD-P250VM-A

Symbol	Name
MF	Fan motor
I.B	Indoor controller board
A.B	Address board
S.B	Surge absorber board
IFB	External input/output board
TB2	Power source terminal bed
TB5	Transmission terminal bed
TB15	Transmission terminal bed
TB21	Terminal bed for distant location on/off <No voltage or current>
TB22	Terminal bed for distant location display
TB23	Terminal bed for distant location on/off <With voltage and current>
F	Fuse<6A>
F1	Fuse<5A>
ZNR,ZNR1,ZNR2	Varistor
T	Transformer
LEV	Electronic linear expan valve
52F	Contact(fan I/D)
51F	Over current relay (fan I/D)
33P1,33P2	Float switch
TH21	Thermistor (inlet temp. detection)
TH22	Thermistor (piping temp. detection/liquid)
TH23	Thermistor (piping temp. detection/gas)
TH24	Thermistor (outlet temp. detection)
SW1(A,B)	Switch (for mode selection)
SW2(LB)	Switch (for capacity code)
SW3(LB)	Switch (for mode selection)
SW4(LB)	Switch (for model selection)
SW8	Switch (normal/local)
SW11(A,B)	Switch (1st digit address set)
SW12(A,B)	Switch (2nd digit address set)
SW14(A,B)	Switch (connection No.set)
SWC	Switch (outlet/inlet temp.control)
X11	Auxiliary relay(check)
Z1	Auxiliary relay(fan)
Z3	Auxiliary relay(fan failure detection)
L1	LED display (failure)
L2	LED display (status)
L3	LED display (check)
L4	LED display (power supply)
RC	MA Remote controller
F4	Fuse<1A>

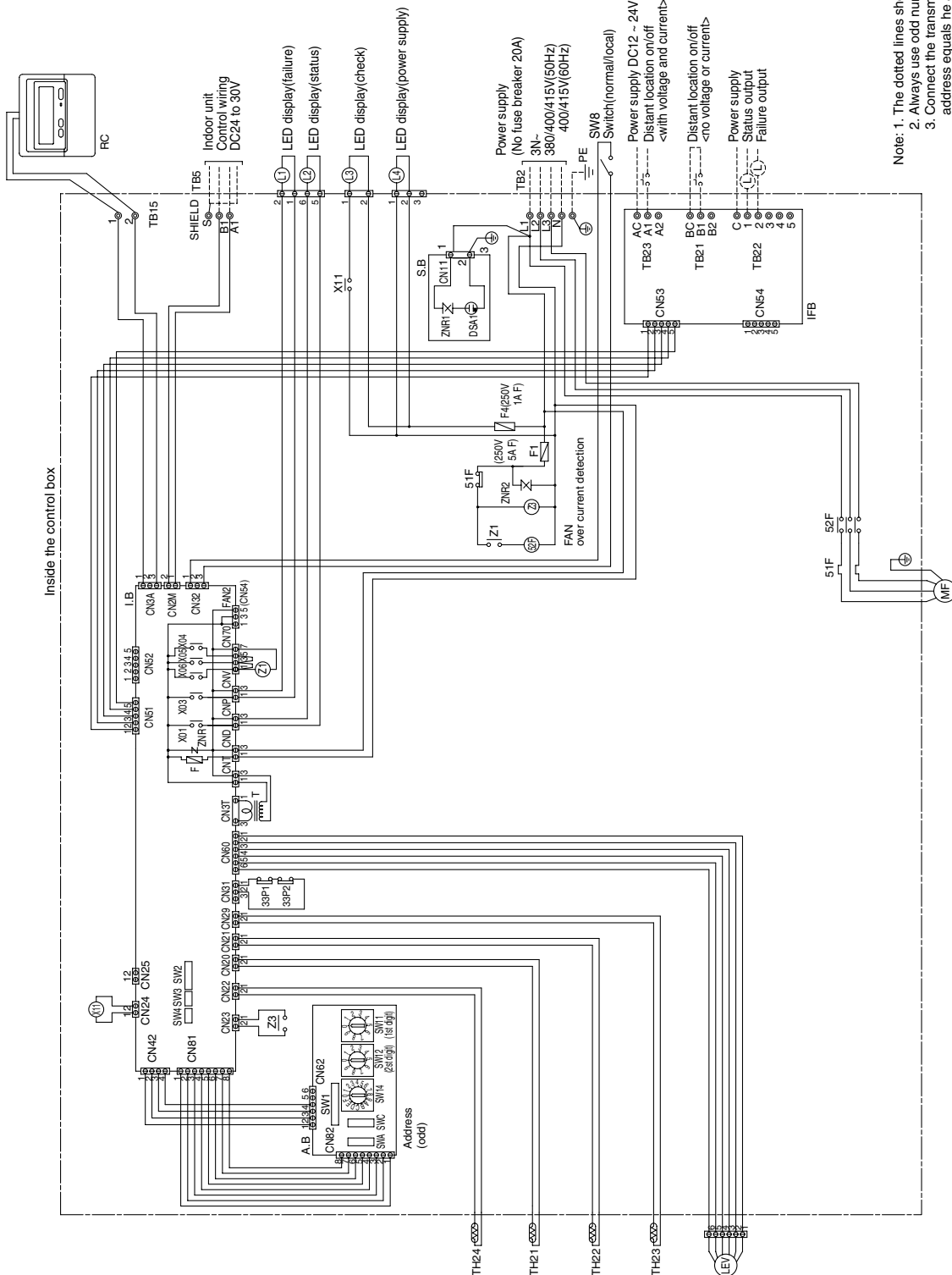

- Note: 1. The dotted lines show field wiring.
 2. Always use odd numbers for the indoor unit address.
 3. Connect the transmission line from indoor unit to outdoor unit whose address equals the address of the connected indoor unit + 50.
 4. Conventions: ⊕terminal bed; ⊖ connector; □ board-insertion connector or fastening connector of control board.

(2) PFD-P500VM-A

Symbol	Name
MF	Fan motor
LB1, LB2	Indoor controller board
A.B1, A.B2	Address board
S.B	Surge absorber board
IFB	External input/output board
TB2	Power source terminal bed
TB5-1, -2	Transmission terminal bed
TB15	Terminal bed for distant location on/off
TB21	<No voltage or current >
TB22	Terminal bed for distant location display
TB23	Terminal bed for distant location on/off
F	Fuse-6A>
F1	Fuse-5A>
F4	Fuse-1A>
ZNR, ZNR1, ZNR2	Varistor
T	Transformer
LEV1, 2	Electronic linear expan.valve
52F	Contactor(fan ID)
51F	Over current relay (fan ID)
33P-1, -2, 33P2-1, -2	Float switch
TH21-1, TH21-2	Thermistor (inlet temp. detection)
TH22-1, TH22-2	Thermistor (piping temp. detection/liquid)
TH23-1, TH23-2	Thermistor (piping temp. detection/gas)
TH24-1, TH24-2	Thermistor (outlet temp. detection)
SW1(A, B)	Switch (for mode selection)
SW2(I, B)	Switch (for capacity code)
SW3(I, B)	Switch (for mode selection)
SW4(I, B)	Switch (for model selection)
SW8	Switch (normal/local)
SW11(A, B)	Switch (1st digit address set)
SW12(A, B)	Switch (2nd digit address set)
SW14(A, B)	Switch (connection No.set)
SWC	Switch (outlet/inlet temp.control)
X11-X12	Auxiliary relay(check)
Z1-Z2	Auxiliary relay(fan)
Z3	Auxiliary relay(fan failure detection)
L1	Lamp display (No1.failure)
L2	Lamp display (No2.failure)
L3	Lamp display (status)
L4	Lamp display (check)
L5	Lamp display (power supply)
RC	MA Remote controller

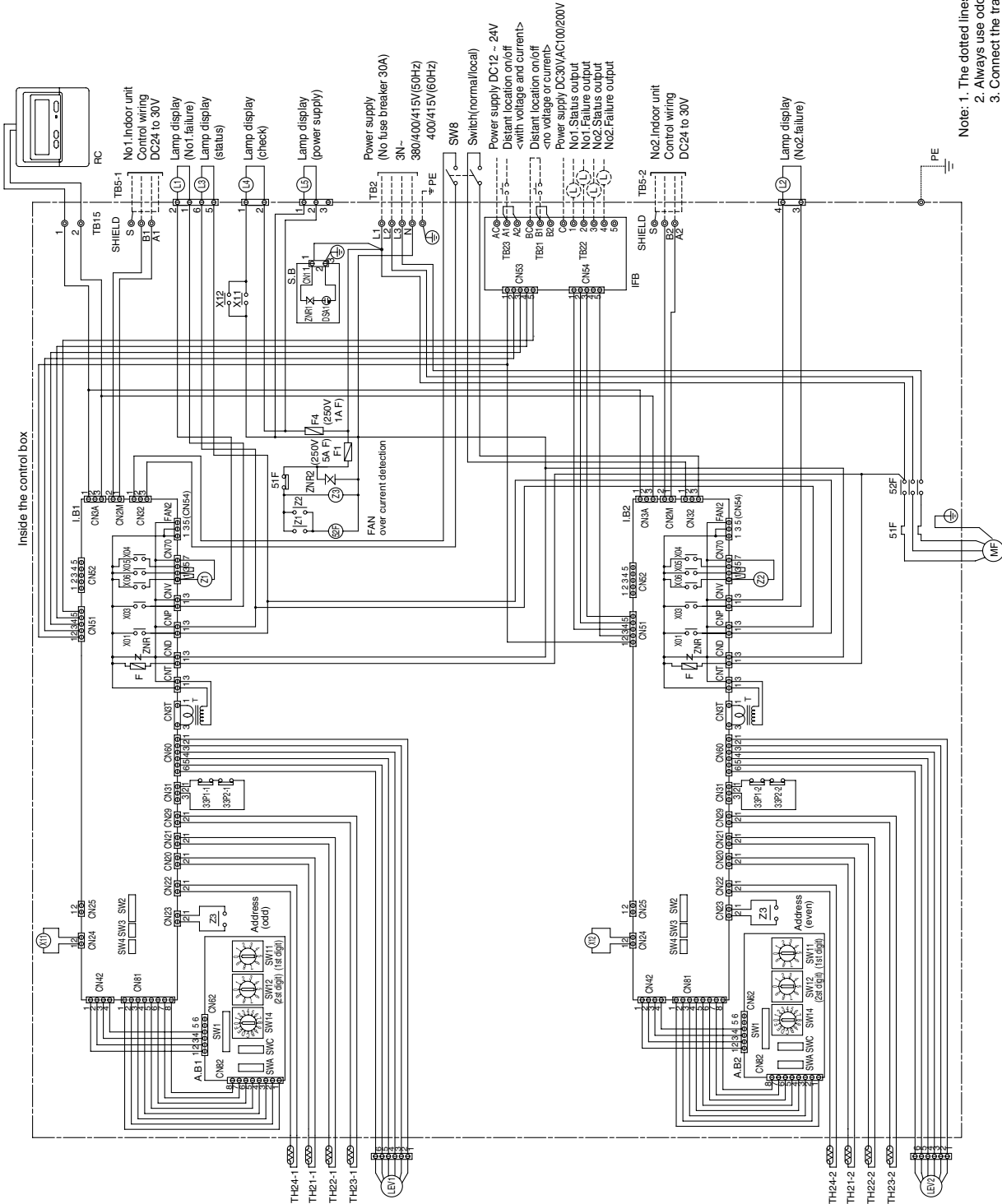

- Note:
- The dotted lines show field wiring.
 - Always use odd numbers for the indoor unit address.
 - Connect the transmission line from indoor unit to outdoor unit whose address equals the address of the connected indoor unit + 50.
 - Conventions: ⊕, terminal bed; ⊕, connector; ⊕, board-insertion connector or fastening connector of control board.

IV. Refrigerant Circuit

Refrigerant Circuit Diagram

< PUD-P250YMF-C >

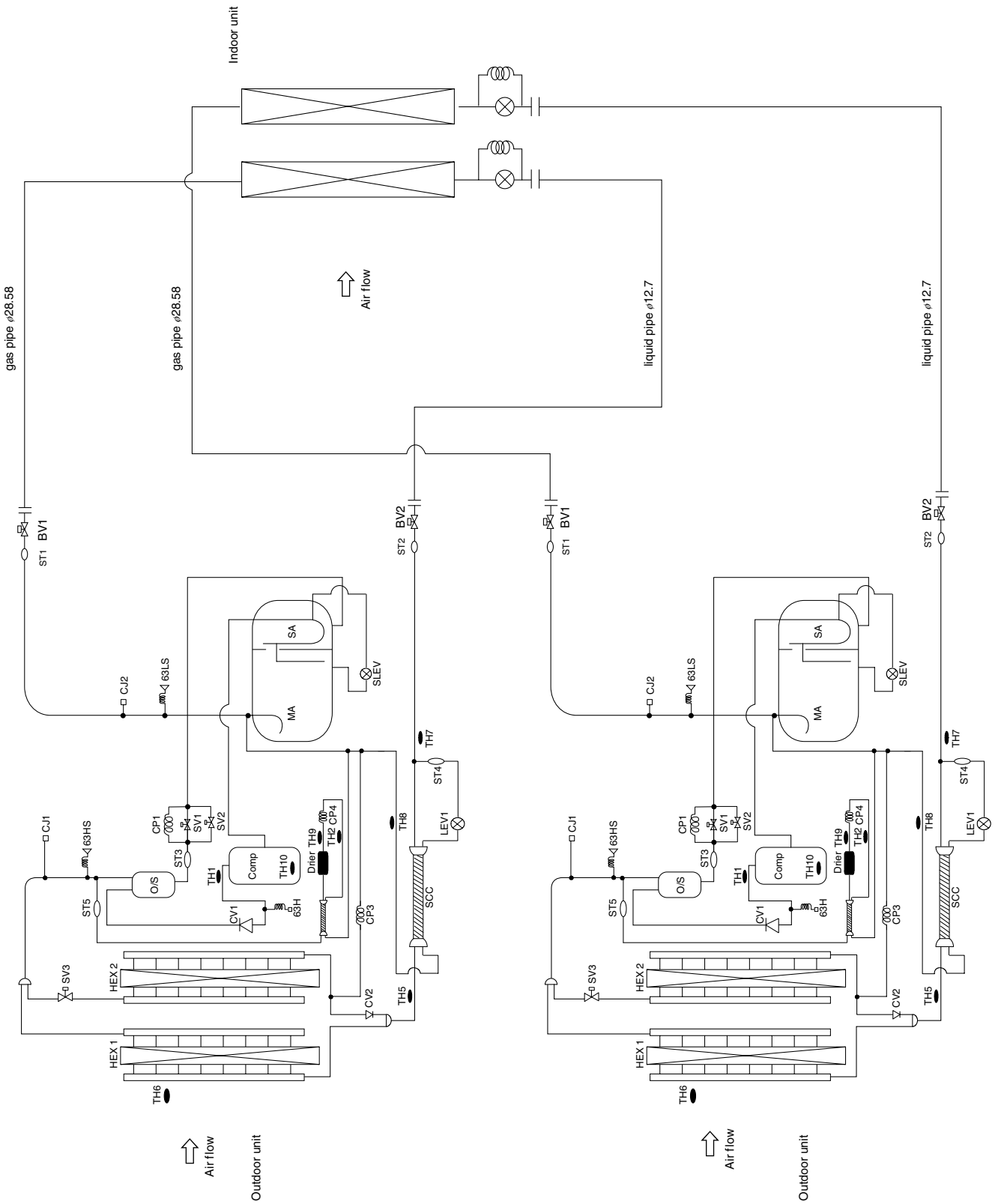

2 List of Major Component Functions

(1) Outdoor Unit

< PUD-P250YMF-C >

Name	Symbol (function)	Application	Specification	Check method
Compressor	MC	Adjust refrigerant circulation by controlling operating frequency and capacity control valve with operating pressure.	Low pressure shell scroll type with capacity control mechanism Winding resistance: Each phase 0.388Ω (20°C)	
High pressure sensor	63HS	1) High press. detection. 2) Frequency control and high pressure protection	Pressure 0~2.94MPa Vout 0.5~3.5 V	
Low pressure sensor	63LS	1) Detects low pressure 2) Calculates the refrigerant circulation configuration. 3) Protects the low pressure	Pressure 0~0.98MPa Vout 0.5~3.5 V	
Pressure switch	63H	1) High pressure detection 2) High pressure protection	Setting 2.94MPa OFF	Continuity check
Thermistor	TH1 (discharge)	1) Discharge temperature detection 2) High pressure protection	$R_{120}=7.465k\Omega$ $B_{25/120}=4057$ $R_t = 7.465 \exp\left\{4057\left(\frac{1}{273+t} - \frac{1}{273+120}\right)\right\}$ 20°C : 250kΩ 70°C : 34kΩ 30°C : 160kΩ 80°C : 24kΩ 40°C : 104kΩ 90°C : 17.5kΩ 50°C : 70kΩ 100°C : 13.0kΩ 60°C : 48kΩ 110°C : 9.8kΩ	Resistance value check
	TH2 (low pressure saturation temperature)	1) Detects the saturated vapor temperature. 2) Calculates the refrigerant circulation configuration. 3) Controls the compressor frequency. 4) Controls the outdoor unit's fan air volume.	$R_0=33k\Omega$ $B_{0/100}=3965$ $R_t = 33 \exp\left\{3965\left(\frac{1}{273+t} - \frac{1}{273+0}\right)\right\}$ -20°C : 92kΩ -10°C : 55kΩ 0°C : 33kΩ 10°C : 20kΩ 20°C : 13kΩ 30°C : 8.2kΩ	Resistance value check
	TH5 (piping temperature)	1) Frequency control 2) Defrost control and liquid level detection at heating	$R_0=15k\Omega$ $B_{0/100}=3460$ $R_t = 15 \exp\left\{3460\left(\frac{1}{273+t} - \frac{1}{273+0}\right)\right\}$	
	TH6 (outdoor air temperature)	1) Outdoor air temperature detection 2) Fan control, liquid level heater, and opening setting for oil return	0°C : 15kΩ 10°C : 9.7kΩ 20°C : 6.4kΩ 25°C : 5.3kΩ 30°C : 4.3kΩ 40°C : 3.1kΩ	
	TH7 (subcool coil outlet temperature)	Subcool coil bypass LEV (LEV1) control		
	TH8 (subcool coil bypass outlet temperature)	Subcool coil bypass LEV (LEV1) control		
	TH9	1) Detects the CS circuit fluid temperature. 2) Calculates the refrigerant circulation configuration.		

Name	Symbol (function)	Application	Specification	Check method
Thermistor	TH10	1) Detects compressor shell temperature 2) Compressor overheating protection	$R_{120} = 7.465k\Omega$ $B_{25/120} = 4057R = 17$ $R_t = 7.465 \exp\left\{4057 \left(\frac{1}{273+t} - \frac{1}{393}\right)\right\}$ 20°C : 250kΩ 70°C : 34kΩ 30°C : 160kΩ 80°C : 24kΩ 40°C : 104kΩ 90°C : 17.5kΩ 50°C : 70kΩ 100°C : 13.0kΩ 60°C : 48kΩ 110°C : 9.8kΩ	Resistance check
	THHS	Controls inverter cooling fan according to THHS temperature	$R_{50} = 17k\Omega$ $B_{25/120} = 4170$ $R_t = 17 \exp\left\{4170 \left(\frac{1}{273+t} - \frac{1}{323}\right)\right\}$ 0°C : 181kΩ 25°C : 50kΩ 10°C : 105kΩ 30°C : 40kΩ 20°C : 64kΩ 40°C : 26kΩ	Resistance check
Solenoid Valve	SV1 (Discharge-Suction Bypass)	1) High/low pressure bypass at starting/stopping and capacity control at low load 2) Suppresses discharge pressure	AC220~240V Opens when energized Closed when de-energized	Continuity check with a tester
	SV2 (Charge-Suction Bypass)	Capacity control, high pressure rise, and low pressure drop suppression (Back-up system for frequency control)		
	SV3	Control of heat exchanger capacity		
Electronic Expansion Valve	SLEV (Oil Return)	Adjusts liquid refrigerant (oil) return from accumulator	DC12V Stepping Motor Driving Valve 0~480 pulses (direct-activity type)	Same as LEV but the resistance level is different (Refer to LEV Troubleshooting)
	LEV1 (SC Coil)	Adjusts bypass flow from outdoor unit during cooling operation		
Heater	CH1 (Crankcase Heater)	Heating refrigerant in compressor	Cord heater AC240V MC...1280Ω 45W	Resistance check
Motor	MF	Controlling concentration capability	AC380~415V F-type 8P Output 0.38kW	Resistance check 

(2) Indoor Unit

< PFD-P250,500VM-A >

Name	Symbol (function)	Application	Specification	Check method
Electronic Expansion Valve	LEV	Adjusts superheat at outdoor unit heat exchanger outlet in cooling operation	DC12V Opening of stemming motor driving valve 0~2000 pulses	Continuity check with tester (Refer to checking) White-red-orange Yellow-brown-blue Yellow brown blue
Thermistor	TH21 (Inlet air temp.)	Controls Indoor Unit Intake (thermostat)	$R_0 = 15k\Omega$ $B_{0/80} = 3460$ $R_t = 15 \exp\left\{3460\left(\frac{1}{273+t} - \frac{1}{273}\right)\right\}$ 0°C : 15kΩ 30°C : 4.3kΩ 10°C : 9.7kΩ 40°C : 3.1kΩ 20°C : 6.4kΩ 25°C : 5.3kΩ	Resistance check
	TH22 (Piping temp.)	Controls indoor unit (freeze prevention, Evaporating temp. detection)		
	TH23 (Gas piping temp.)	LEV control during cooling operation (Superheat detection)		
	TH24 (Outlet air temp.)	Controls indoor unit discharge (thermostat)		
Float Switch	33P1, 33P2 33P1-1, 33P1-2 33P2-1, 33P2-2	Detects drain pan water level	Contact Resistance: Under 250mΩ B contact type	Continuity check with tester
Motor	MF	Sends air	PFD-P250VM-A AC400V Type E 4P Output 3.7kW	Resistance check 0.45Ω±10%/2 phases
			PFD-P500VM-A AC400V Type B 4P Output 5.5kW	Resistance check 1.72Ω±10%/2 phases

V. Control

I Dip Switch Functions and Factory Settings

[1] Outdoor Unit

< PUD-P250YMF-C >

(1) Main Board

Switch	Function	Function according to switch operation		Switch setting timing		
		OFF	ON	ON	OFF	
SWU	1~2	Unit address setting.				Set to numbers between 51 and 90 with the dial switch.
SW1	1~8	Self-diagnosis/operation monitoring.				Refer to section VIII Display on the LED monitor on the outdoor unit board.
	9~10	-				Set to OFF.
SW2	1	-				-
	2	Deletion of connection information.	Storage of refrigerant system connection information.	Deletion of refrigerant system connection information.	Before power is turned on.	
	3	Deletion of error history.	Storage of IC/OC error history.	Deletion of IC/OC error history.	After power on. (when switching from OFF to ON)	
	4	Refrigerant amount adjustment.	Normal Control.	Refrigerant amount adjustment operation.	After power on. (when switching from OFF to ON)	Becomes invalid 2 hours after compressor start.
	5	Changing Tem change timing.	3 minutes.	5 minutes.	After power on. (when switching from OFF to ON)	
	6	Outdoor-air sensor abnormality/refrigerant overfilling disregarded.	Errors valid.	Disregard errors.	After power on. (when switching from OFF to ON)	
	7	Stand-by mode switching.	Operation starts upon IPM bus voltage error detection.	Operation starts upon IPM bus voltage error detection or detection of outdoor air temperature reading at 5°C.	Before power on.	
	8	-				-
	9	-				-
	10	-				-
SW3	1	SW3-2 function valid/invalid.	SW3-2 function invalid.	SW3-2 function valid.	After power on. (when switching from OFF to ON)	
	2	Indoor unit test run.	All indoor units stopped.	All indoor unit on test run.	After power on and when SW3-1 is ON.	
	3	-				-
	4	Compressor operating frequency change.	Fmax=72Hz	Fmax=90Hz	After power on. (when switching from OFF to ON)	
	5	-				-
	6	Pump down operation.	No action	Operation starts	After power on and when compressor is stopped. (When switching from OFF to ON)	
	7	Switching thermostat control function.	Valid	Invalid	After power on. (when switching from OFF to ON)	
	8	-				-
	9	-				-
	10	-				-
SW4	1	SW4-2 Function valid/invalid.	Invalid	Valid	After power on. (when switching from OFF to ON)	
	2	Refrigerant composition correction value.	The value changes as the following by the switching of ON and OFF switch. ±0%→+3%→+6%→+9%→+12%→-6%→-3%→±0%		When SW4-1 is ON.	
	3	-				-
	4	-				-
	5	-				-
	6	-				-
	7	-				-
	8	-				-
	9	Switching solenoid valve SV3's control type.	OFF	ON	-	
	10	-				-

Note : Factory setting: SWU1-2 = 00, SW4-9 = on, all the others are set to OFF.

(2) Dip Switch (Control Board)

Switch	Function	Function according to switch		Switch setting timing		
		OFF	ON	OFF	ON	
SW1	1	IDC sensor error-detection mode selection	· Above 20A immediately before starting · Below 10A five seconds after starting and thereafter	· Above 20A immediately before starting (Below 10A five seconds after start up will not be detected as error)	Anytime power on	
	2	–	–	–	–	
	3	–	–	–	–	
	4	Serial (IPM) communication	With communication	Without communication	Anytime power on	

Note) All of the above switches are set to off when shipped from the factory.

[2] Indoor Unit

< PFD-P250,500VM-A >

(1) Dip Switch (Control Board)

① SW1,3

Switch	Function	Function According to Switch Operation		Switch Set Timing		Notes
		OFF	ON	OFF	ON	
SW1	1	–	–	–	During unit stoppage (Remote controller OFF)	
	2	–	–	–		
	3	–	–	–		
	4	–	–	–		
	5	Remote display selection	Fan output display	Thermo ON		
	6	–	–	–		
	7	–	–	–		
	8	–	–	–		
	9	–	–	–		
	10	–	–	–		
SW3	1	–	–	–		
	2	–	–	–		
	3	–	–	–		
	4	–	–	–		
	5	–	–	–		
	6	–	–	–		
	7	LEV targets Tc (high temperature) at heating	Disabled	Enabled		
	8	–	–	–		

Notes 1)  Settings in the shaded areas indicate factory settings

2) Setting timing for DIPSW SW 1, 2, 3, 4 is during unit stoppage (remote OFF). It is not necessary to reset the settings by power-off.

② SW2

Unit Type	P250
Capacity (model type) Code	50
SW2 sets	

Notes 1) There are two control boards inside indoor unit P500 to accommodate two-refrigerant circuit system. The capacity code for one of the control boards is P250-50.

2) There is one control board inside indoor unit P250 to accommodate one-refrigerant circuit system.

③ SW4



PFD-P250VM-A

	SW4			
	1	2	3	4
Relay Switch	OFF	ON	OFF	OFF

PFD-P500VM-A

	SW4			
	1	2	3	4
Relay Switch	OFF	OFF	OFF	OFF

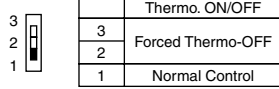
(2) Slide Switch (Address Board)

Switch		Function	Function According to Switch	Switch-Set Timing
SWA	1 ~ 3	Forced Thermo OFF (used by indoor units using multiple refrigerants)		Anytime after power on
SWC	1 ~ 2	Suction/Discharge Temperature Switch	Option  Factory Setting : Discharge Temp. Control Factory Setting  Option : Suction Temp. Control ※ When choosing between suction and discharge temperature controls, make sure that the settings for the two address boards are identical.	Anytime after power on

2 Controlling the Outdoor Unit

< PUD-P250YMF-C >

< General Information on Control >

Each of the two outdoor units in a 2-refrigerant circuit that are connected to the indoor units performs the following control functions independently:

[1] Initial Control

- When turning on the power, the initial processing of the microcomputer is given top priority.
- Control processing of the operation signals is suspended until the initial processing is completed. (Initial processing involves data processing in the microcomputer and initial setting of each of the LEV opening. This process will take up to 1 minute.)

[2] Control at startup

- When DipSW2-7 are on (Factory setting is OFF), the outdoor temperature is below 5°C, and the unit is started within 2 hours of power on, the unit will not start for up to 35 minutes.
- For 3 minutes after start up, the upper limit of the frequency is 60 Hz.

[3] Bypass control

Each of the solenoid bypass valves on high-pressure and low-pressure sides (SV1, SV2), performs the following functions:

(1) Bypass Solenoid Valves (SV1, SV2) (Both SV1 and SV2 are open when set to ON)

Operation condition	SV1		SV2	
	ON	OFF	ON	OFF
At compressor startup	4 minutes ON		4 minutes ON	
After thermostat resumes operation or after a 20-second restart	2 minutes ON		2 minutes ON	
In cooling mode and while the compressor is stopped	Always ON		OFF	
When operation stops	3 minutes ON		OFF	
During oil recovery	Always off during oil recovery after continuous operation at low frequencies.		Always off during oil recovery after continuous operation at low frequencies.	
During operation with the compressor running at the frequency level of 20Hz When low-pressure drops (3 or more minutes after startup)	-		When low pressure (LPS) goes below 0.098MPa	When low pressure (LPS) exceeds 0.196MPa
When high pressure (HPS) rises	When high pressure exceeds 2.70MPa	30 seconds have past and the high pressure is below 2.35MPa	ON when high pressure exceeds 2.5MPa	30 seconds have past and high pressure is below 2.25MPa
When high pressure rises while the unit is operating with the compressor running at the frequency of 20Hz (3 or more minutes after startup)	-		When high pressure (HPS) exceeds the pressure limit	When high pressure (HPS) goes below 1.96MPa
When discharge temperature rises (3 or more minutes after startup)	-	-	When discharge temperature exceeds 130°C	When discharge goes below 115°C
When low pressure (LPS) drops	-	-	within 20 minutes of startup:LPS<0.049MPa 20 or more minutes from startup:LPS<0.098MPa	within 20 minutes of startup:LPS<0.147MPa 20 or more minutes from startup:LPS<0.196MPa

<Example of SV1 operation>

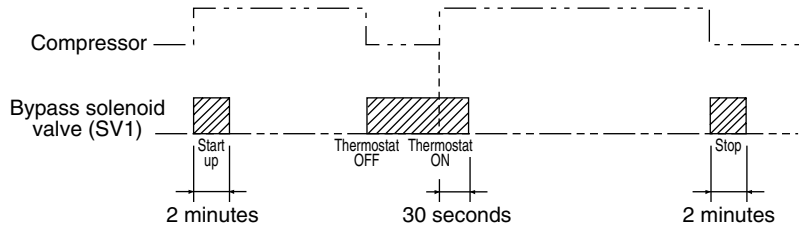

[4] Frequency Control

- Depending on the capacity required, frequency is controlled to approximate evaporation temperature (Te) to the target evaporation temperature (Tem) during cooling operation.
- Depending on the capacity required, the target evaporation temperature (Tem) changes as the following:
 - When lacking in capacity Tem is lowered
 - When the capacity exceeds the needs Tem is raised

Minimum and maximum Tem Value
 $-10^{\circ}\text{C} \leq \text{Tem} < 25^{\circ}\text{C}$

- The frequency changes are shown below:

Frequency change	Speed
30~72Hz	2 Hz/sec.

(1) Discharge Temperature Control

- When discharge temperature of the compressor (TH1) exceeds the upper limit during operation, the frequency is reduced by 5Hz.
- Control is performed 20 seconds after compressor start, then every 20 seconds thereafter.
- Operating temperature is 124°C.

(2) Periodical Frequency Control

Frequency controls other than the ones performed in respond to the status change or for protection are called periodical frequency control. They are performed as the following:

- ① Periodical control cycle
 Periodical frequency control is started at the following time.
 - a) 20 seconds after the start of compressor
 - b) 1 minute after frequency control prompted by discharge temperature or pressure limit
- ② Amount of Frequency Change
 The amount of frequency change is controlled to approximate the target value (Tem) depending on the evaporation temperature (Te).
- ③ Back up of frequency control by the bypass valves
 When the compressor is running at 20Hz, the frequency is backed up by turning bypass valve (SV2) on.

When 3 minutes have past after the compressor started operation at 20Hz, the valve is on when low pressure (LPS) is below 0.098MPa and off when it is above 0.196MPa.

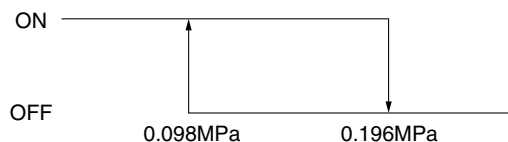

[5] Oil-Return Control

- Oil-return LEV (SLEV) is determined by the operating capacity of the compressor and outside temperature.
- During compressor stoppage and for 10 minutes after startup, the opening of SLEV is 75.
- When the compressor is stopped, the opening of SLEV is 0.

[6] Outdoor Unit Fan

(1) Control Method

- Depending on the capacity required, outdoor unit fan is controlled by phase control, and corrections are made using compression temperature (Tc) to keep evaporation temperature (Te) constant.

(2) Control

- Outdoor unit fan stops when compressor is stopped. (Except in the presence of input from snow sensor)
- Operates at full-speed for 5 seconds of startup.

[7] Subcool Coil Control (Linear Expansion Valve (LEV1))

- Controlled every 20 seconds to keep the amount of superheat constant, using bypass outlet/inlet temperatures of the subcool coil (TH2, TH8).
- The degree of opening is controlled, depending on the inlet/outlet temperatures of the subcool coil (TH5, TH7), high pressure (HPS), discharge temperature (TH1).
When the compressor is stopped, the valve is in the closed position (0).
- During TH8 error, the valve will be fixed at a certain degree of opening.

[8] Circulating composition sensor (CS circuit)

- As shown in the drawing below; the CS circuit has the structure to bypass part of the gas discharged from the compressor through the capillary tube to the suction side of the compressor, exchange heat before and after the capillary tube, and produce two phase (gaseous and liquid) refrigerant at the capillary tube outlet. The dryness fraction of refrigerant at the capillary tube outlet is estimated from the temperature of low pressure two phase (gaseous and liquid) refrigerant at the capillary outlet (TH2) and the pressure (LPS) to calculate the composition of refrigerant circulating the refrigeration cycle (α OC). In this series the high-pressure liquid refrigerant temperature is calculated based on the high pressure and ambient air temperature values. It is found by utilizing the characteristic that the temperature of two phase (gaseous and liquid) R407C under a specified pressure changes according to the composition and dryness fraction (gas-liquid ratio in weight).
- The condensing temperature (Tc) and the evaporating temperature (Te) are calculated from α OC, high pressure (HPS), and low pressure (LPS).
- The compressor frequency, the outdoor fan, and others are controlled according to the condensing temperature (Tc) and the evaporating temperature (Te).
- CS circuit configuration (Outline drawing)

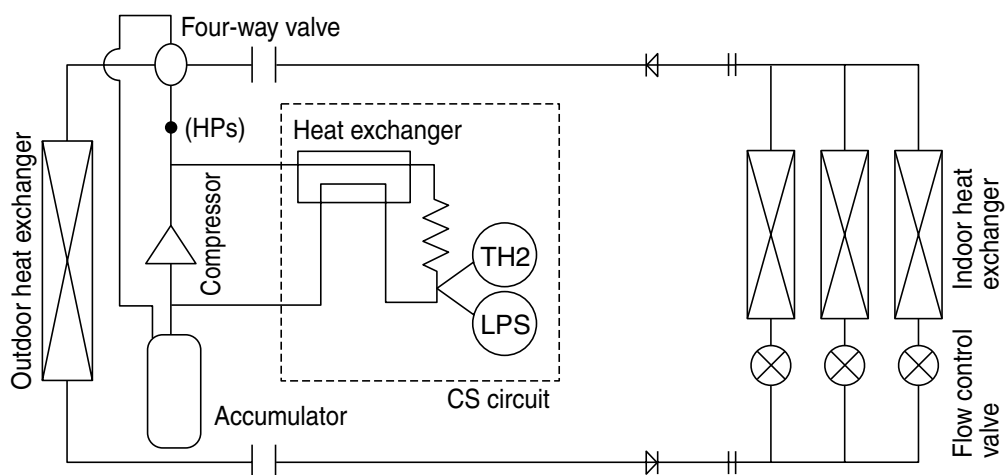

[9] Emergency Operation Mode

Emergency Operation is an operation that is run at 50 to 70 percent of the system's maximum capacity when experiencing problems, depending on the type of problems listed below. It is automatically run after the following abnormalities have been detected.

(1) Starting Emergency Operation

- When the following problems are detected, the system runs an emergency operation, displaying error codes.
- During this operation, near normal operation is run, ignoring the following abnormal operation data. Some of the actuators will run at a fix state during this operation.

Chart: Types of errors in which emergency operation can be run

Types of Errors		Error codes
High Pressure Sensor Error		5201
Thermistor Error (Except for TH1,TH6,THHS)	TH2	5102
	TH5	5105
	TH7	5107
	TH8	5108
	TH10	5112
	Error Detection by the Sensor	
	Open/Short Detection	

(2) Stopping the Emergency Operation Mode

Emergency operation mode is stopped in the following situations:

- When abnormal mode is reset
 - *How to reset abnormal mode
 - When stopping operation with MA remote controller or pushing the reset button
 - When stopping indoor unit or pushing the reset button
- When detecting another abnormality during an emergency operation
 - *i.e. Detecting problems with TH5 while running an emergency operation after detecting problems with TH21.

(3) Miscellaneous

- When encountering problems other than the ones listed above, the system, except for the fan (unless problems are found with the fan-in which case the fan will also stop), will stop.
- When problems are found in only one of the two units of a 2-refrigerant circuit, only the unit with the problems will run an emergency operation or stop its operation, and the other unit will keep running its operation.
- Emergency operation is intended only as a first aid until the unit is serviced. Have the unit serviced without delay to restore a normal operation.

[10] Capacity Control Between Outdoor Units (For P500 Type Only)

Capacity control between outdoor units consists of the following:

- ① Starting up only one of the outdoor units (the one with lower address number) at start-up when the load is light.
- ② Stopping one of the outdoor units (the one with higher address number) when the load drops.

They are performed automatically under the following conditions:

(1) Starting Conditions

- ① When it is determined that the load is less than 50%, using suction temperature as a reference.
- ② Operation frequencies of both indoor and outdoor units remain near the minimum level three minutes after start-up.

(2) Stopping Conditions

When operation frequency of the running unit rises up near the maximum capacity.

When it is determined that the load is over 50%, using suction temperature as a reference.

When compressor stops while running only one unit.

[11] Control-Block Diagram

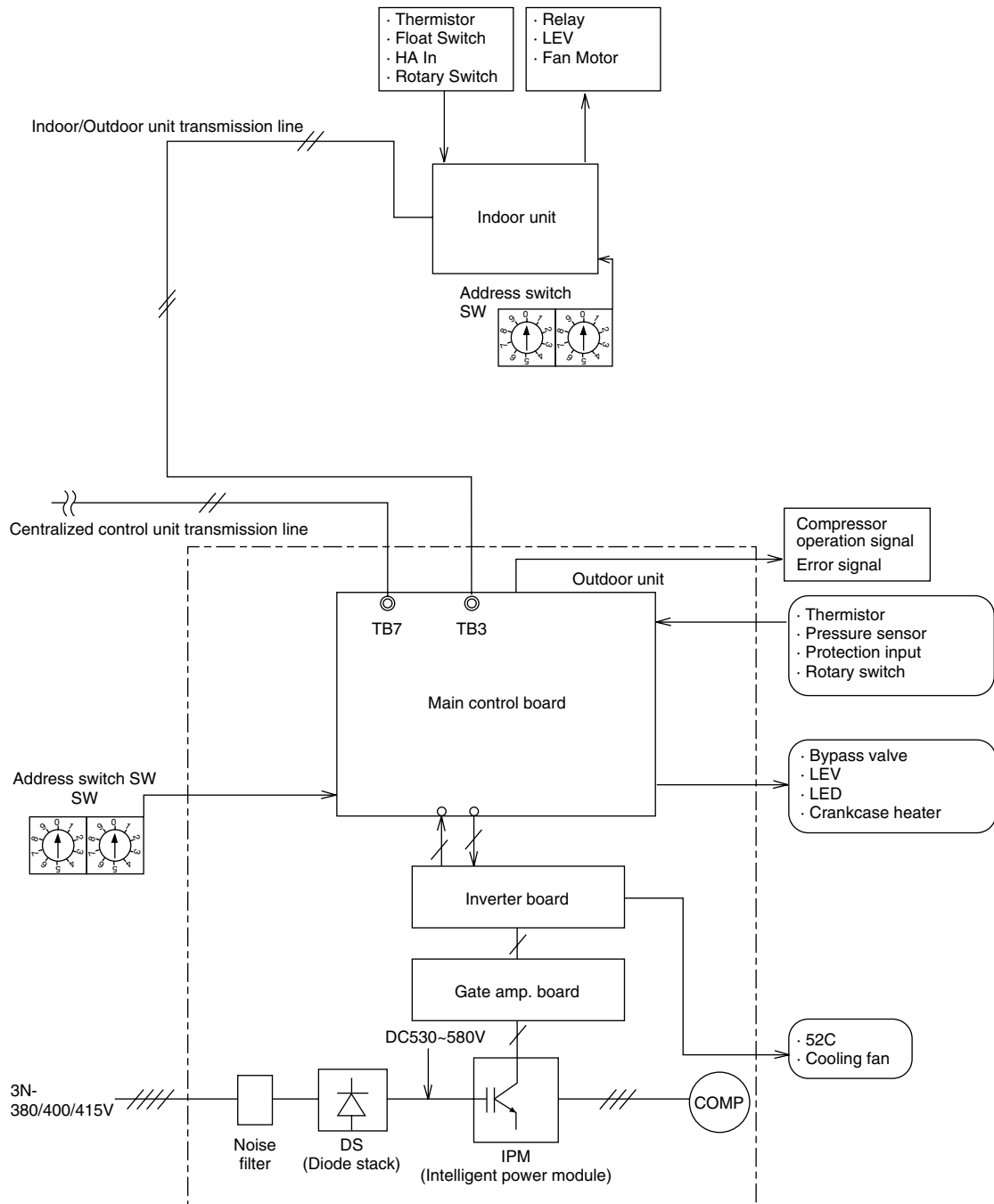

[12] Operation Modes

(1) Indoor Unit Operation Modes

①	Cooling Mode
②	Stop Mode

(2) Outdoor Unit Operation Modes

①	Cooling Mode (corresponding indoor unit is in cooling mode)
②	Stop Mode (corresponding indoor unit is in Fan mode or stopped)

3 Controlling the Indoor Unit

< Indoor unit control >

Inside the indoor units 16 and 20 HP are two control boards to accommodate two-refrigerant circuits, and there is one control board inside indoor unit 10HP to accommodate one-refrigerant circuits. Each refrigerant circuit is controlled independently. See the following for various functions they perform.

[1] Thermostat Functions

(1) Functions of Thermostat and Selection of Function

- There are two control methods. One is to use suction temperature; the other is to use discharge temperature.
 - The switches on the address board inside indoor unit is used to switch between the above options.
 - Factory setting: Discharge Temperature Control.
 - When changing the setting, set the switches on both address boards inside the control to OPTION to use suction temperature control. Set the switches to STANDARD to use discharge temperature control.
 - Make sure that the settings on the two address boards inside 16 and 20P units match.
- *: Not applicable to 10HP

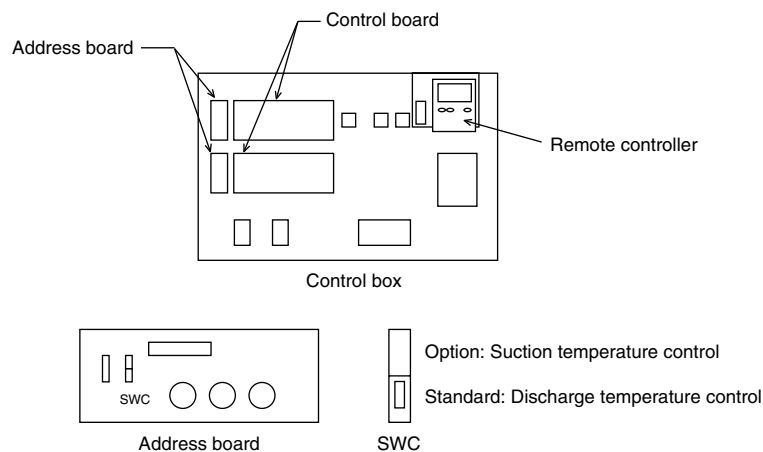

(2) Thermostat Reading

- ① Discharge Temperature Control (SWC is set to Standard)
- (a) Thermo ON Condition
- Three minutes have past since thermo OFF AND
 - TH24 - Target Temperature $>1^{\circ}\text{C}$ AND
 - TH21 is higher than when thermo is OFF.
TH24: Discharge thermistor
TH21: Suction thermistor
- (b) Thermo OFF Condition
- < When outdoor unit Dipsw3-7 are ON >
- 30 minutes have past since thermo ON AND
 - TH24- Target Temperature $< -1^{\circ}\text{C}$ has been detected for 10 minutes
OR TH24 - Target Temperature $< 15^{\circ}\text{C}$ was detected
- < When Outdoor unit Dipsw 3-7 are OFF >
- Two minutes have past since thermo ON
 - TH24 - Target Temperature $< -1^{\circ}\text{C}$ has been detected for 5 minute.
 - When operating with the compressor running at its minimum capacity.
- ② Suction Temperature Control (SWC is set to Option.)
- (a) Thermo ON Condition
- Three minutes have past since thermo OFF AND
 - TH21 - Target Temperature $> 1^{\circ}\text{C}$
- (b) Thermo OFF Condition
- < When outdoor unit Dipsw 3-7 are ON >
- Thirty minutes have past since thermo ON AND
 - TH21 - Target Temperature $< -1^{\circ}\text{C}$ has been detected for 10 minutes OR TH21 - Target Temperature $< -5^{\circ}\text{C}$ was detected.
- < When outdoor unit Dipsw 3-7 are OFF >
- Two minutes have past since thermo ON AND
 - TH21 - Target Temperature $< -1^{\circ}\text{C}$ has been detected for 5 minute.
 - When operating with the compressor running at its minimum capacity.

[2] Actuator Control

(1) LEV Control

- Depending on the condensation pressure, LEV control is set at a certain level at start-up.
- After the start-up, the degree of LEV opening is adjusted every minute to keep within a certain range the superheat detected by Thermistors TH22 (liquid) and TH23 (gas) in the indoor unit.
- Depending on the operating condition of the outdoor unit, a controlling method other than the one described above may be used.
- When suction or discharge temperature nears the target temperature, superheat control value rises and LEV opening narrows.
- LEV's full range of opening-closure is 41 pulses.

(2) Fan Control

Whether the thermostat is on or off, the fan stays on except during operation stoppage.

Exception: Fan stops when problem with the fan is detected (Error Code 4109).

※ Fan problems may be experienced in the following situations: Surge breaker trip (51F) or malfunctions of sub relays Z1, Z2, or Z3.

(3) Float Switch Control

The unit will stop when the contact point (B contact) loses its contact for more than one minute (i.e. loosened float parts, disconnected wire, unfastened connector etc.)

(4) Indicator Lamp

Indicator lamps on the front side of the unit indicate the operation status of the indoor unit.

Power Supply Lamp (White) : ON upon power on. OFF upon power off.

Operation Lamp (Green) : ON during operation. OFF during stoppage.

Error Lamp (Red) : Comes on upon detection of abnormalities in each refrigerant circuit.
Indicator OFF during normal operation and after a reset.

Maintenance Lamp (Yellow) : ON when maintenance switch of the indoor unit is on.
OFF upon normal shutdown.

[3] Temperature Setting Range

Both suction and discharge temperatures can be set between 14 and 30°C from the centralized controller.

※ Depending on the operating conditions, target temperature and actual discharge/suction temperatures may not match. For example, even if the target discharge temperature is set at 15°C, if the load exceeds the capability of the unit, the actual temperature will not reach 15°C.

[4] Emergency Operation Mode

Emergency operation is an operation that is run at 50 to 70 percent of the system's normal capacity when experiencing problems, depending on the type of problems listed below. It is automatically run after the following abnormalities have been detected.

(1) Starting an Emergency Operation

- When the following problems are detected, the system runs an emergency operation, displaying error codes.
- During this operation, near normal operation is run, ignoring the following abnormal operation data. Some of the actuator will run at a fixed state during this time.

Chart: Types of errors in which emergency operation can be run

Thermistor Error	Types of Errors		Error codes
	TH21	Open/Short Detection	
	TH22		5101
	TH23		5102
	TH24		5103
			5104

(2) Stopping the Emergency Operation

Emergency operation mode is stopped in the following situations:

- When abnormal mode is reset
 - ※ How to reset an abnormal mode
 - When stopping operation with the MA remote controller or pushing the reset button
 - When stopping indoor unit or pushing the reset button
- When detecting another abnormality during an emergency operation
 - ※ i.e. Detecting problems with TH5 while running an emergency operation after detecting problems with TH21.

(3) Miscellaneous

- When encountering problems other than the ones listed above, the system, except for the fan (unless problems are found with the fan-in which case the fan will also stop), will stop.
- When problems are found in only one of the two units of a 2-refrigerant circuit, only the unit with problems will run an emergency operation or stop its operation, while the other unit will keep running its normal operation.
- Emergency operation is intended only as a first aid until the unit is serviced. Have the unit serviced without delay to restore a normal operation.

[5] Three-minute restart-suspension mode

The unit will be in a three-minute restart-suspension mode (same operation as Thermo OFF) in any of the following situations.

- When the demand for outdoor unit changes from Thermo ON to Thermo OFF.
 - When operation mode changes from normal to emergency mode.
 - When anti-freeze mode is completed.
- ※ Outdoor unit also has a three-minute restart-suspension mode, and it works independently of the indoor unit.

[6] Anti-Freeze Control

(1) Starting Conditions

This operation will start when all of the following conditions are met:

- Thermo ON status has been detected for 16 minutes.
- TH22 (liquid pipe temp. Thermistor) < 1°C has been detected for 20 minutes.

(2) Control Operation

The unit will be in the same condition as Thermo OFF condition for six minutes. When the following conditions are met, the unit will be in a 20-second restart-suspension mode.

(3) Stopping Conditions

When either of the following conditions is met:

- $HT22 \leq 10^{\circ}\text{C}$
- Six minutes have elapsed since the beginning of this operation.

[7] Operation during Electrical Power Failure

After the controller in this air conditioning unit receives signals indicating power failure or an instantaneous drop in voltage, unless the unit receives a command not to restart, it will resume its operation after power supply is restored.

Depending on the duration of power outage, the following operations will be run.

Duration of Power Outage	Unit Operation
Shorter than 6msec	Both indoor and outdoor units will stay on.
Longer than 6msec and Shorter than 50msec (Note1, Note2)	It is recognized by the unit as an instantaneous power outage Indoor Unit: The fan stays on. Outdoor Unit: Compressor stops, then resumes its operation 3 minutes later. ※ Note on the outdoor unit: When the power supply is cut off for longer than 6 msec, compressor will stop.
Longer than 50msec (Note1, Note2)	It is recognized by the unit as power outage. Air-conditioning unit will stop (incl. fan and compressor). It will resume operation after the power has been restored.

Note 1: When indoor unit is in the maintenance mode (SW8 local mode), it will not resume operation even after the power has been restored.

Note 2: After the unit resumes its operation, MA remote controller will display 'HO' for fifteen seconds, during which time the remote controller will not respond. To turn off the unit during this time, turn off the power with an electric leak breaker.

4 Operation Flow Chart

[1] Mode Selection Flow Chart

(1) Indoor Unit (Cooling Mode)

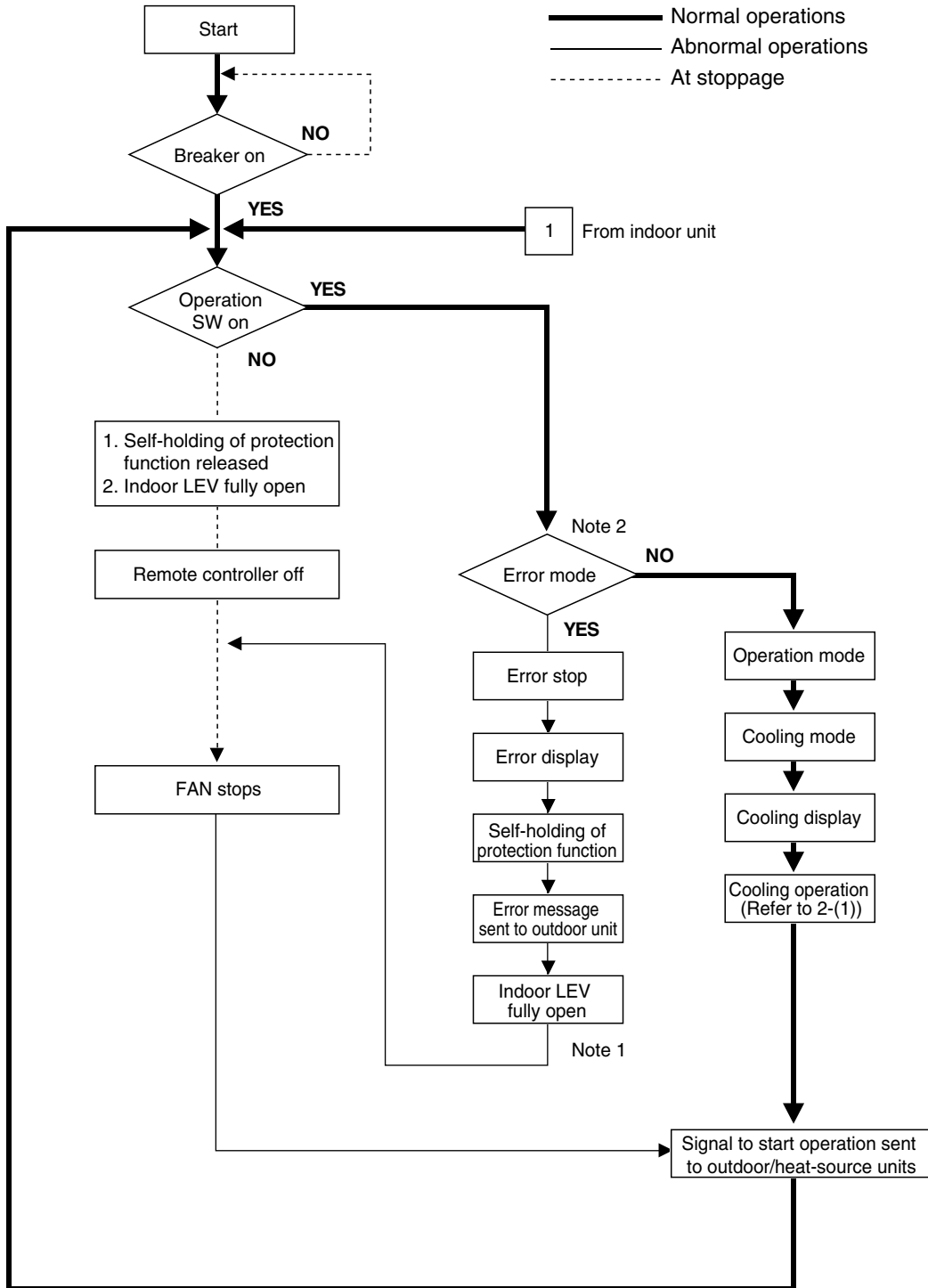

Note 1: Indoor LEV fully open = 41 pulse.

Note 2: Error mode can either be on the indoor unit error mode or outdoor unit error mode. In either case, connected indoor or outdoor unit will stop. (During emergency operation mode, the unit will keep its operation.)

(2) Outdoor Unit (Cooling Mode)

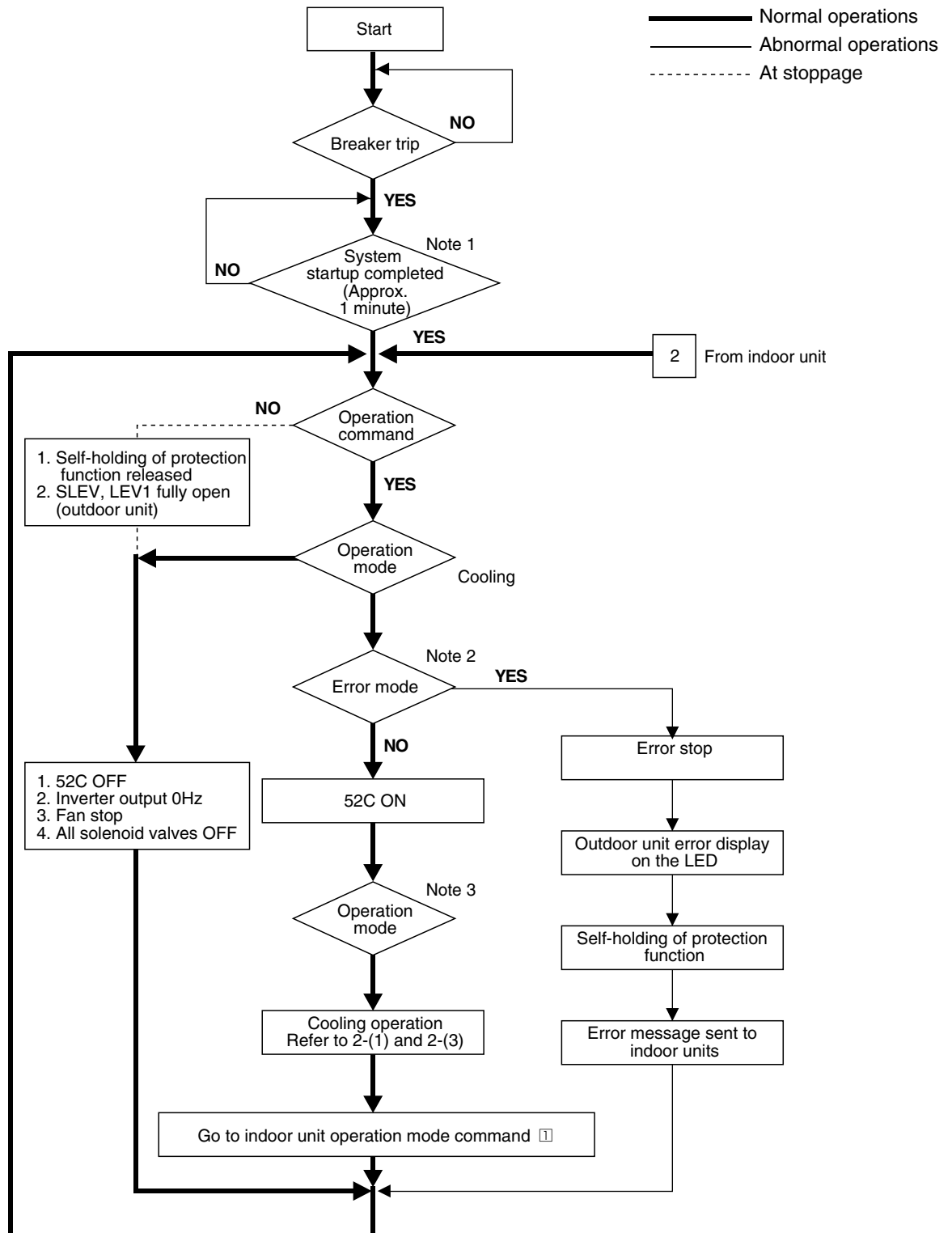

Note 1: Searches for indoor unit remote control address information and group information for one minute after power on.

Note 2: There could be problems with either indoor units or outdoor units. In either case, the corresponding outdoor units or indoor units will make an error stop. (While running an emergency operation mode, these units will remain in operation.)

Note 3: The operation mode is determined by the indoor unit.

[2] Operation in each Mode

(1) Cooling Operation

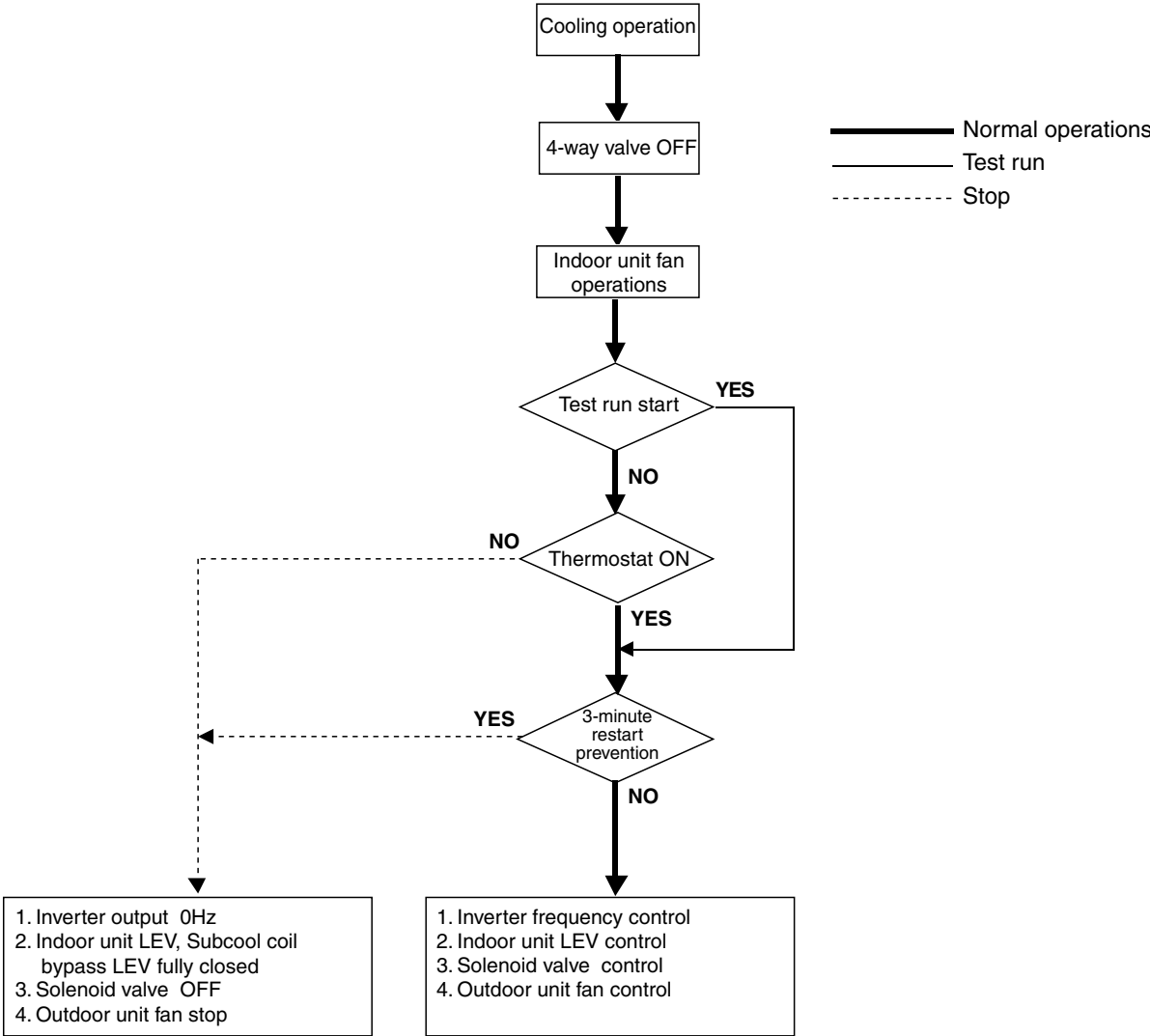

VI. Refrigerant Amount Adjustment

1 Operating Characteristics and Refrigerant Amount

It is important to understand the relationship between refrigerant amount and operation characteristics. Use the following information when adjusting refrigerant amount.

[1] Operating Characteristics/Refrigerant Amount

1	During cooling operations, the demand for refrigerant tends to increase in proportion to an increase in the number of operating indoor units (refrigerant in the accumulator decreases), though the change is small.		
2	Having refrigerant in the accumulator, there is little change in discharge temperature when increasing or decreasing refrigerant amount.		
3	Tendency of discharge temperature change	In cooling operation, discharge temperature is more likely to rise when operation load is high (outdoor temperature is high etc.) than when indoor target temperature is set low.	Comparison including control system.
		The lower the operation frequency, the more likely discharge temperature will rise because of a drop in compressor efficiency	
4	Compressor shell temperature is 20 to 70 k higher than low pressure saturation temperature when refrigerant amount is adequate. When the difference between pressure shell temperature and low pressure saturation temperature is smaller than 10k, overfilling of refrigerant is suspected.		

2 Checking and Adjusting Refrigerant Amount

[1] Symptoms

The symptoms shown in the table below are possible signs of excess or lack of refrigerant. Be sure to adjust refrigerant amount in the Refrigerant-Amount Adjustment Mode after determining the appropriate amount of refrigerant to be added or drained by checking the operation status and performing self-diagnosis using LED.

1	The unit stops, displaying 1500 (refrigerant overfill) on remote controller.	Refrigerant Overfill
2	Operating frequency does not reach its optimal level, resulting in insufficient power.	Insufficient Refrigerant
3	The unit stops, displaying 1102 (discharge temp. abnormality) on the controller.	
4	Intermittent Fault Check Code 1243 is recorded in the error history.	

[2] Refrigerant Volume

(1) Items to check during operation

Operate all the indoor units in cooling mode, and check discharge temperature, sub-cooling, low pressure, inlet temperature, and shell-bottom temperature.

	Condition	Evaluation
1	Discharge temperature is high (over 125°C)	Tend towards under fill
2	Low pressure is extremely low	
3	Inlet super heat is high (normal range = under 20K)	
4	Shell bottom temperature is high (The difference between low pressure saturation temperature and shell bottom temperature is 70K or greater)	Tend towards overfill
5	Shell temperature is low (The difference between shell temperature and low-pressure saturation temperature is 10K or less).	
6	Discharge superheat is low (normal range = 20K and above)	

(2) Checking refrigerant Volume Using LED

Set Self-Diagnosis Switch (SW1) as shown and check the history of operation regarding refrigerant.

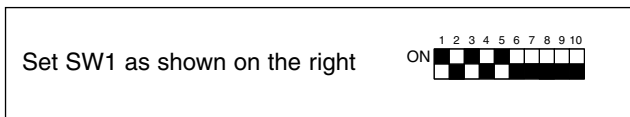

When LED 8 lights up: It indicates that the unit is close to being stopped due to overfilling of refrigerant.

[3] Amount of Refrigerant to Be Added

At the time of shipment, outdoor unit is charged with the amount of refrigerant shown in the following table. Additional refrigerant necessary for extension pipes is not included. Add refrigerant on site as necessary.

Outdoor Unit Model Name	PUD-P250YMF-C
Amount of refrigerant included	8.5kg

[Formula]

The amount of refrigerant to be added is calculated using the diameter of extension pipes and their length in meters.

$$\text{Amount of additional refrigerant (kg)} = (0.12 \times L_1) + 2.0$$

L₁: Length of liquid pipe with a diameter of 12.7 in meters

* Round up the figure in the 1/100th digit (i.e. 18.54kg →18.6kg)

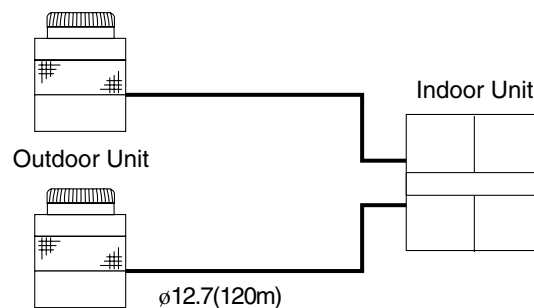

Pipes shown above are liquid pipes.
ø12.7 : 120m

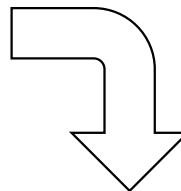

From the formula above

$$\text{Amount of refrigerant to be added} = (0.12 \times 120) + 2 = 16.4\text{kg}$$

$$\text{Amount of refrigerant to be added} = 16.4\text{kg}$$

* Fill each refrigerant circuit (in a 2-refrigerant circuit system) with the above amount.

⚠ Caution

Charge the system with liquid refrigerant.

If gas refrigerant is used, the composition of refrigerant in the cylinder will change and will lead to power loss.

3 Refrigerant-Adjustment Operation Mode

Procedures described in this unit is meant to be used on a first-aid basis, as it is difficult to accurately adjust refrigerant volume. Using the flow chart in the following section, determine if the unit has an adequate amount of refrigerant.

[1] Procedures (only for air-cooled outdoor units)

Follow the procedures below when refrigerant needs to be added or drained.

- 1 Turn on function switch SW2-4 on the main control board of outdoor unit to go into Refrigerant-Adjustment Operation Mode.

Operation	During cooling operation, LEV1 of outdoor unit opens more than usual.
-----------	---

- 2 When the SW1 of the main control board of outdoor unit is set as follows, circulation composition alpha OC will be displayed on the LED.

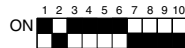

Note 1: Even when it is indicated at the initial stage of Refrigerant-Amount Adjustment Mode operation that the unit contains an adequate amount of refrigerant, it may later turn out that the unit either has an excessive or insufficient amount of refrigerant. (When operation of refrigerant circuit has stabilized).

- ① When refrigerant amount is truly adequate

TH5 through TH7 of the outdoor unit are under 5K, and SH of the indoor unit is between 6 and 13K.

- ② Even if currently within adequate range, the possibility exists that, with a passage of time, the amount of refrigerant will be found to be inadequate.

In the case when outdoor unit TH5, 6, and 7 are above 5K and indoor unit SH is between 6 and 13K.

Note 2: When high pressure has not reached 1.37MPa or above, it may be difficult to accurately assess the amount of refrigerant in the system.

Note 3: Based on the flow chart that follows, and using TH1, TH5, TH7, and Tc, adjust refrigerant amount. TH1, TH5, TH7, and Tc can be displayed on the Self-Diagnosis Switch on the main control of the outdoor unit.

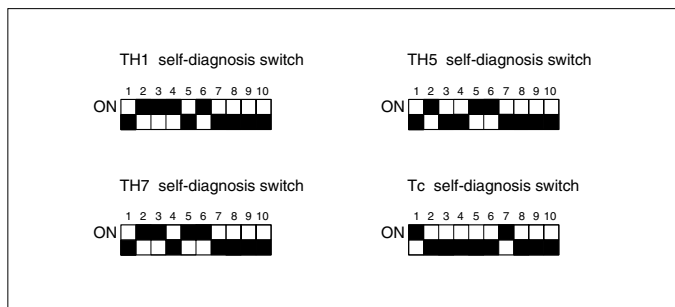

Remedies	A	When adjusting refrigerant amount in cooling mode and when Note 2 above applies, wait until TH5, 6, and 7 on the outdoor reach 5K and SH6,7,8, and 9 of the indoor unit to fall between 6 and 9K; then, determine the correct amount of refrigerant.
	C	To monitor the SH of the indoor unit, turn on the Self-Diagnosis Switch of the outdoor unit, and monitor it with the LED.

< Air-Cooling Outdoor Unit >

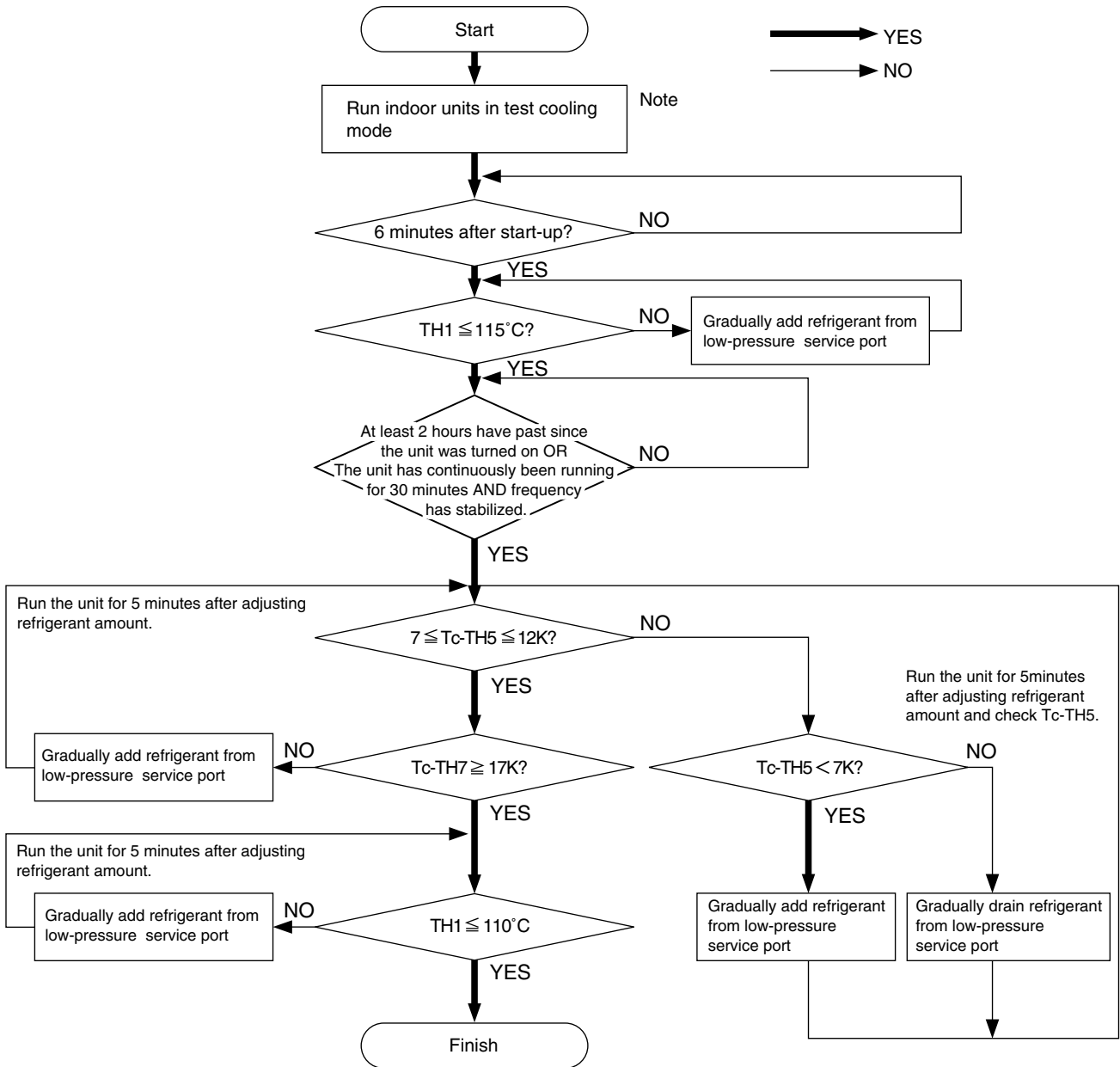

Note) Operate using DIPSW 3-1 and 3-2

⚠ Caution
Do not release drained refrigerant into the air.

⚠ Caution
Use liquid refrigerant.
If gas refrigerant is used, the composition of the refrigerant in the cylinder will change and lead to a loss of power.

VII. Troubleshooting

I List of Check Code

Check Code	Check Content	
0403	Serial transmission abnormality	
0900	Trial operation	
1102	Discharge temperature abnormality	
1111	Low pressure saturation temperature sensor abnormality (TH2)	
1112	Low pressure saturation	Liquid level sensing temperature sensor abnormality (TH4)
1113	temperature abnormality	Liquid level sensing temperature sensor abnormality (TH3)
1301	Low pressure abnormality	
1302	High pressure abnormality	
1500	Overcharged refrigerant abnormality	
1501	Low refrigerant abnormality	
1505	Suction pressure abnormality	
2500	Leakage (water) abnormality	
2502	Drain pump abnormality	
2503	Drain sensor abnormality	
4103	Reverse phase abnormality	
4109	Fan motor abnormality	
4115	Power supply sync signal abnormality	
4200	VDC sensor/circuit abnormality	
4220	Bus voltage abnormality	
4230	Radiator panel overheat protection	
4240	Over load protection	
4250	IPM Alarm output / Bus voltage abnormality / Over Current Protection	
4260	Cooling fan abnormality	
5101	Thermal sensor abnormality	Air inlet (TH21:IC)
		Discharge (TH1:OC)
5102		Liquid pipe (TH22:IC)
		Low pressure saturation (TH2:OC)
5103		Gas pipe (TH23:IC)
5105		Liquid pipe (TH5)
5106		Ambient temperature (TH6)
5107		SC coil outlet (TH7)
5108		SC coil bypass outlet (TH8)
5109		CS circuit (TH9)
5110		Radiator panel (THHS)
5112		Compressor shell temperature (TH10)
5201	Pressure sensor abnormality	
5301	[6]	IAC sensor/circuit abnormality
	[13]	IAC sensor miss-wiring abnormality
6600	Multiple address abnormality	
6602	Transmission processor hardware abnormality	
6603	Transmission circuit bus-busy abnormality	
6603	Transmission Bus-Busy error	
6606	Problem communication with the transmission processor	
6607	No-acknowledgement error	
6608	No-response error	

[] : Error detail No.

Check Code	Check Content
6831	MA communication reception error (no reception)
6832	MA communication reception error (frequency restoration error)
6833	MA communication transmission error (H/W error)
6834	MA communication reception error (start bit detection error)
7100	Total capacity error
7101	Capacity code error
7102	Connected units exceeds the limit
7105	Address setting error
7106	Characteristics setting error
7109	Connection setting error
7110	Failure to set connection information

[] : Error detail No.

2 Intermittent Fault Check Code (outdoor units only)

Trouble Delay Cope	Trouble Delay Content
1202 (1102)	Preliminary discharge temperature abnormality or preliminary discharge thermal sensor abnormality (TH1)
1205	Preliminary liquid pipe temperature sensor abnormality (TH5)
1211 (1111)	Preliminary low pressure saturation abnormality or preliminary low pressure saturation sensor abnormality (TH2)
1214	Preliminary THHS sensor/circuit abnormality
1216	Preliminary sub-cool coil outlet thermal sensor abnormality (TH7)
1217	Preliminary sub-cool coil bypass outlet thermal sensor abnormality (TH8)
1219	Preliminary sub-cool coil bypass inlet thermal sensor abnormality (TH9)
1221	Preliminary ambient temperature thermal sensor abnormality (TH6)
1243 (1501)	Preliminary compressor shell thermal sensor abnormality (TH10)
1402 (1302)	Preliminary high pressure abnormality or preliminary pressure sensor abnormality
1600 (1500)	Preliminary overcharged refrigerant abnormality
1601	Preliminary lacked refrigerant abnormality
1605 (1505)	Preliminary suction pressure abnormality
1607	CS circuit block abnormality
1608	Control valve abnormality
1659 (1559)	Oil balance circuit abnormality
4300 (0403)	[9] Preliminary serial transmission abnormality
4300 (5301)	[6] IAC sensor/circuit abnormality
	[13] IAC sensor miss-wiring abnormality
4320 (4220)	Preliminary bus voltage abnormality
4330 (4230)	Preliminary heat sink overheating abnormality
4340 (4240)	Preliminary overload protection
4350 (4250)	[1] IPM Alarm output/Bus voltage abnormality
	[11] IAC sensor overcurrent abnormality
4360 (4260)	Preliminary cooling fan abnormality

Please refer to () : Check Code. [] : Error detail No.

③ Self-Diagnosis and Problem-Solving Using Check Codes

[1] Mechanical

Check code	Meaning, detecting method	Cause	Checking method & Countermeasure	
0403	Serial transmission abnormality	If serial transmission cannot be established between the MAIN and INV boards.	1) Wiring is defective.	Check 1, the connections, 2, contact at the connectors and 3, for broken wires in the following wiring. CNRS2 - CNRS3 CNAC2 - TB1B
			2) Switches are set wrong on the INV board.	SW1-4 on the INV board should be OFF.
			3) A fuse (F01) on the INV board is defective.	If the fuse is melted, (if the resistance between the both ends of fuse is ∞), replace the fuse.
			4) The circuit board is defective.	If none of the items in 1) to 3) is applicable, and if the trouble reappears even after the power is switched on again, replace the circuit board by the following procedure (when replacing the circuit board, be sure to connect all the connectors, ground wires, etc. securely). ① If serial transmission is restored after the INV board only is replaced, then the INV board is defective. ② If serial transmission is not restored, reinstall the INV board and replace the MAIN board. If serial transmission is restored, the MAIN board is defective. ③ If serial transmission is not restored by ① and ② above, replace both boards.
1102	Discharge temperature abnormality (Outdoor unit)	<p>1. When 140°C or more discharge temperature is detected during operations (the first time), outdoor unit stops once, mode is changed to restart mode after 3 minutes, then the outdoor unit restarts.</p> <p>2. When 140°C or more temp. is detected again (the second time) within 30 minutes after stop of outdoor unit, emergency stop is observed with code No. "1102" displayed.</p> <p>3. When 140°C or more temp. is detected 30 or more minutes after stop of outdoor unit, the stop is regarded as the first time and the process shown in 1 is observed.</p> <p>4. 30 minutes after stop of outdoor unit is intermittent fault check period with LED displayed (1202).</p>	1) Gas leak, gas shortage.	See Refrigerant amount check .
			2) Overload operations.	Check operating conditions and operation status of indoor/outdoor units.
			3) Poor operations of indoor LEV. 4) Poor operations of OC controller LEV	Check operation status by actually performing cooling or heating operations. Cooling : Indoor LEV Outdoor LEV1 See Trouble check of LEV and solenoid valve .
			5) Setting error of connection address.	Check address setting of indoor unit connection.
			6) Poor operations of ball valve.	Confirm that ball valve is fully opened.
			7) Outdoor unit fan block, motor trouble, poor operations of fan controller→Heating (Heating-only, Heating-main). [3) ~ 7) : Rise in discharge temp. by low pressure drawing.]	Check outdoor fan. See Trouble check of outdoor fan .
			8) Gas leak between low and high pressures. [4-way valve trouble, compressor trouble, solenoid valve SV1 trouble.]	Check operation status of cooling-only or heating-only.
			9) Poor operations of solenoid valve SV2. [Bypass valve SV2 can not control rise in discharge temp.]	See Trouble check of solenoid valve .
			10) Thermistor trouble.	Check resistance of thermistor.
			11) Thermistor input circuit trouble on control circuit board.	Check inlet temperature of sensor with LED monitor.

Check code		Meaning, detecting method	Cause	Checking method & Countermeasure
1111	Low pressure saturation temperature trouble	Low pressure saturation temperature sensor abnormality (TH2)	1) Gas leak, Gas shortage.	See Refrigerant amount check.
2) Insufficient load operations.			Check operating conditions and operation status of outdoor unit.	
3) Poor operations of indoor LEV. 4) Poor operations of OC controller LEV:			Check operation status by actually performing cooling-only or heating-only operations. Cooling-only : indoor LEV Outdoor LEV1	
5) Setting error of connection address.		Check address setting of indoor unit connector.		
6) Poor operations of ball valve.		Confirm that ball valve is fully opened.		
7) Short cycle of indoor unit. 8) Clogging of indoor unit filter. 9) Fall in air volume caused by dust on indoor unit fan. 10) Dust on indoor unit heat exchanger. 11) Indoor unit block, Motor trouble.		Check indoor unit, and take measures to trouble.		
[5)~10) : Fall in low pressure caused by evaporating capacity in cooling-only cooling-principal operation.]				
12) Short cycle of outdoor unit. 13) Dust on outdoor heat exchanger.		Check outdoor unit, and take measures to trouble.		
14) Indoor unit fan block, motor trouble, and poor operations of fan controller. [11)~13) : Fall in low press. caused by lowered evaporating capacity in heating-only heating-principal operation.]		Check outdoor unit fan. See Trouble check of outdoor unit fan.		
15) Poor operations of solenoid valve SV2. [Bypass valve (SV2) can not control low pressure drop.]		See Trouble check of solenoid valve.		
16) Thermistor trouble (TH2~TH10).	Check resistance of thermistor.			
17) Pressure sensor abnormality.	See Trouble check of pressure sensor.			
18) Control circuit board thermistor abnormality and pressure sensor input circuit abnormality.	Check inlet temp. and press. of sensor by LED monitor.			
19) Poor mounting of thermistor (TH2~TH10).				
1112	Low pressure saturation temperature trouble	Liquid level detecting temperature sensor abnormality (TH4)	4. 30 minutes after stop of outdoor unit is intermittent fault check period with LED displayed. Note: 1. Low press. saturation temperature trouble is not detected for 3 minutes after compressor start, and finish of defrosting operations, and during defrosting operations. 2. In the case of short/open of TH2~TH4 sensors before starting of compressor or within 10 minutes after starting of compressor, "1111," "1112," or "1113" is displayed too.	
1113		Liquid level detecting temperature sensor abnormality (TH3)		

Check code	Meaning, detecting method	Cause	Checking method & Countermeasure	
1301	Low pressure abnormality	<p>When starting from the stop mode for the first time, (if at the start of bind power transmission, the end of bind power transmission, and in the mode when the thermostat goes OFF immediately after the remote control goes ON, the following compressor start time is included), if the low pressure sensor before starting is at 0.098MPa, operation stops immediately.</p>	<p>1) Internal pressure is dropping due to a gas leak. 2) The low pressure sensor is defective. 3) Insulation is torn. 4) A pin is missing in the connector, or there is faulty contact. 5) A wire is disconnected. 6) The control board's low pressure sensor input circuit is defective.</p>	Refer to the item on judging low pressure sensor failure.
1302	High pressure abnormality 1 (Outdoor unit)	1) When press. sensor detects 2.47MPa or more during operations (the first time), outdoor unit stops once, mode is changed to restart mode after 3 minutes, then the outdoor unit restarts.	<p>1) Poor operations of indoor LEV. 2) Poor operations of outdoor LEV1</p>	<p>Check operations status by actually performing cooling or heating operations. Cooling : Indoor LEV Outdoor LEV1 See Trouble check of LEV and solenoid valve.</p>
		2) When 2.94MPa or more pressure is detected again (the second time) within 30 minutes after stop of outdoor unit, error stop is observed with code No. "1302" displayed.	3) Setting error of connection address.	Check address setting of indoor unit connector.
		3) When 2.47MPa or more pressure is detected 30 or more minutes after stop of outdoor unit, the detection is regarded as the first time and the process shown in 1 is observed.	4) Poor operations of ball valve.	Confirm that ball valve is fully open-ed.
		4) 30 minutes after stop of outdoor unit is intermittent fault check period with LED displayed.	<p>5) Short cycle of indoor unit. 6) Clogging of indoor unit filter. 7) Fall in air volume caused by dust on indoor unit fan. 8) Dust on indoor unit heat exchanger. 9) Indoor unit fan block, motor trouble. [4)~9) : Rise in high pressure caused by lowered condensing capacity in heating-only and heating-principal operation.]</p>	Check indoor unit and take measures to trouble.
		5) Error stop is observed immediately when press. switch 2.94 ⁺⁰ _{-1.5} MPa operates in addition to pressure sensor.	<p>10) Short cycle of outdoor unit. 11) Dust on outdoor unit heat exchanger.</p>	Check outdoor unit and take measures to trouble.
			<p>12) Outdoor unit fan block, motor trouble, poor operations of fan controller. [10)~12): Rise in high press.] caused by lowered condensing capacity in cooling-only and cooling-principal operation.</p>	Check outdoor unit fan See Trouble check of outdoor unit fan.
			13) Poor operations of solenoid valves SV1, 2 (Bypass valves (SV1, 2) can not control rise in high pressure).	See Trouble check of solenoid valve.
			14) Thermistor trouble (TH2, TH5, TH6).	Check resistance of thermistor.
	15) Pressure sensor trouble.	Check Trouble check of pressure sensor.		
	16) Control circuit board thermistor trouble, press. sensor input circuit trouble.	Check inlet temperature and press. of sensor with LED monitor.		
	High pressure abnormality 2 (Outdoor unit)	<p>When press. sensor detects 0.098MPa or less just before starting of operation, error stop is observed with code No. "1302" displayed.</p>	<p>1) Fall in internal press. caused by gas leak. 2) Press. sensor trouble. 3) Film breakage. 4) Coming off of pin in connector portion, poor contact. 5) Broken wire. 6) Press. sensor input circuit trouble on control circuit board.</p>	See Trouble check of pressure sensor.

Check code		Meaning, detecting method	Cause	Checking method	
1500	Overcharged refrigerant abnormality	<p>1. When discharge superheat ≤ 10 deg and oil temperature superheat < 15 deg is keeping for 10 minutes or discharge superheat ≤ 20 deg and oil temperature superheat < 15 deg for 15 minutes, outdoor unit stops once, and after 3 minutes, the unit restarts. For 60 minutes after unit stopped is intermittent fault check period.</p> <p>2. When discharge superheat ≤ 10 deg and oil temperature superheat < 15 deg is keeping for 10 minutes or discharge superheat ≤ 20 deg and oil temperature superheat < 15 deg for 15 minutes again (second time), the unit stops and error code 1500 is displayed.</p> <p>3. In case of SW2-6 ON, the detection for the second time is followed by the first time.</p>	1) Excessive refrigerant charge.	Check refrigerant amount.	
			2) Thermistor trouble (TH1, TH10).	Check resistance of thermistor.	
			3) Pressure sensor trouble (63HS).	See trouble shooting of pressure sensor.	
			4) Control circuit board trouble.	Check temperature and pressure sensor with LED monitor.	
1501	Lacked refrigerant abnormality	<p>1. When the unit condition is as follows, the compressor is stopped (1st detection) and after 3 minutes, the compressor is restarted automatically.</p> <p>① $F < 60\text{Hz}$ and $\text{TH10} > 85^\circ\text{C}$ continuously for 60 minutes. ② $F < 60\text{Hz}$ and $\text{TH10} > 95^\circ\text{C}$ continuously for 15 minutes. ③ $F \geq 60\text{Hz}$ and $\text{TH10} > 100^\circ\text{C}$ continuously for 60 minutes. ④ $F \geq 60\text{Hz}$ and $\text{TH10} > 110^\circ\text{C}$ continuously for 15 minutes.</p> <p>2. If the temperature rises again as above within 2 hours after the outdoor unit is stopped (2nd detection), an error stop is performed, and the check code 1501 is displayed.</p> <p>3. If the temperature rises again as above within 2 hours after the outdoor unit is stopped, it becomes the first detection again, and operation is the same as in 1 above.</p> <p>4. The 2 hour period after the outdoor unit stops is the abnormal delay period, and LED display is carried out during the abnormal stop delay.</p>	1) Gas leakage, insufficient gas.	Refer to the item on judging the refrigerant volume.	
			2) Overload operation.	<p>Check the indoor and outdoor unit operating conditions. Actually run the equipment in cooling or heating mode and check the operating condition.</p> <p>Cooling : Indoor LEV Outdoor LEV1 SLEV</p> <p>Refer to the item concerning judging LEV failure.</p>	
			3) Indoor unit LEV operation is faulty.		
			4) Outdoor unit LEV1 operation is faulty.		
			5) Outdoor unit SLEV operation is faulty.		
			6) Ball valve operation is faulty.		Check with the ball valve fully open.
			Insufficient refrigerant abnormality	7) The thermistor is faulty.	Check the thermistor's resistance.
				8) The control board's thermistor input circuit is faulty.	Check the sensor's temperature reading by the LED monitor.

Check code	Meaning, detecting method	Cause	Checking method & Countermeasure
1505	Suction pressure abnormality	<p>1. Judging that the state when the suction pressure reaches 0MPa during compressor operation, the back-up control by gas bypassing will be conducted.</p> <ul style="list-style-type: none"> • Operation while neglecting to open ball valve. Especially for the ball valve at low pressure side. At cooling : Gas side ball valve At heating : Liquid side ball valve • When plural systems are existing, the low pressure abruptly drop at indoor stopping by the erroneous wiring of transmission line (different connection of transmission line and refrigerant piping). • Temporary vacuum condition due to refrigerant distribution unbalance (insufficient refrigerant of low pressure line) immediately after charging refrigerant. 	<p>Once vacuum operation protection is commenced, do not attempt to restart until taking the measures below.</p> <p><Checking method></p> <ul style="list-style-type: none"> • Check ball valve for neglecting to open. • Check extended piping for clogging when ball valve is opened. • Check transmission line for erroneous wiring. (Confirm the correct wiring and piping connection between indoor and outdoor units by operating indoor unit one by one.) <p><Countermeasure></p> <ul style="list-style-type: none"> • After checking with the above method, make error reset by power source reset. • Then operate for 10~15-minutes under the operation mode reverse to that when the vacuum operation protection occurred (Heating if error occurred in cooling, while cooling if it occurred in heating), and then enter into the ordinary operation state.
2500	Leakage (water) abnormality	When drain sensor detects flooding during drain pump OFF.	<p>1) Water leak due to humidifier or the like in trouble.</p> <p>Check water leaking of humidifier and clogging of drain pan.</p>
2502	Drain pump abnormality	When indirect heater of drain sensor is turned on, rise in temperature is 20 deg. or less (in water) for 40 seconds, compared with the temperature detected before turning on the indirect heater.	<p>1) Drain sensor sinks in water because drain water level rises due to drain water lifting-up mechanism trouble.</p> <p>Check operations of drain pump.</p>
			<p>2) Broken wire of indirect heater of drain sensor.</p> <p>Measure resistance of indirect heater of drain sensor. (Normal: Approx. 82Ω between 1-3 of CN50)</p>
			<p>3) Detecting circuit (circuit board) trouble.</p> <p>Indoor board trouble if no other problems is detected.</p>
2503	Drain sensor abnormality	Short/open is detected during drain pump operations. (Not detected when drain pump is not operating.) Short : 90°C or more detected Open : -40°C or less detected	<p>1) Thermistor trouble.</p> <p>2) Poor contact of connector. (insufficient insertion)</p> <p>3) Full-broken or half-broken thermistor wire.</p> <p>Check resistance of thermistor. 0°C : 15kΩ 10°C : 9.7kΩ 20°C : 6.4kΩ 30°C : 4.3kΩ</p>
			<p>4) Indoor unit circuit board (detecting circuit) trouble.</p> <p>Check contact of connector. Indoor port trouble if no other problem is detected.</p>
	Operation of float switch	When float switch operates (point of contact : OFF), error stop is observed with code No. "2503" displayed.	<p>1) Drain up input trouble.</p> <p>Check drain pump operations.</p> <p>2) Poor contact of float switch circuit.</p> <p>Check connect contact.</p> <p>3) Float switch trouble.</p> <p>Check float switch operations.</p>

Check code		Meaning, detecting method	Cause	Checking method & Countermeasure
4103	Reverse phase abnormality	Reverse phase (or open phase) in the power system is being detected, so operation cannot be started.	1) The phases of the power supply (L1, L2, L3) have been reversed.	If there is reverse phase before the breaker, after the breaker or at the power supply terminal blocks TB1A, reconnect the wiring.
			2) Open phase has occurred in the power supply (L1, L2, L3, N).	Check before the breaker, after the breaker or at the power supply terminal blocks TB1A, and if there is an open phase, correct the connections. a) Check if a wire is disconnected. b) Check the voltage between each of the wires.
			3) The wiring is faulty.	Check 1 the connections, 2, the contact at the connector, 3, the tightening torque at screw tightening locations and 4 for wiring disconnections. TB1A~NF~TB1B~CNTR1~F3~T01~CNTR Refer to the circuit number and the wiring diagram plate.
			4) The fuse is faulty.	If F1 on the MAIN board, or F3 is melted, (Resistance between both ends of the fuse is ∞), replace the fuses.
			5) T01 is faulty.	To judge failure of the T01, go to "Individual Parts Failure Judgment Methods."
			6) The circuit board is faulty.	If none of the items in 1) to 5) is applicable, and if the trouble reappears even after the power is switched on again, replace the MAIN board (when replacing the circuit board, be sure to connect all the connectors, etc. securely).
4109	For motor abnormality	If the supplemental relay Z3 has not been energized for a certain length of time, the unit will make an error stop, and the fan output will be off.	1) Over-current breaker trip	<ul style="list-style-type: none"> · Check for restricted movement of fan, worn bearing, and pulley contact. · Check the tension of V belt (to see if it is too tight). · Check the motor. · Malfunction of 51F (with test switch on).
			2) Blown fuse (F1)	· Check for a blown fuse/disconnection.
			3) Supplemental relay (Z3) abnormality	<ul style="list-style-type: none"> · Dislocated or disconnected lead wire, incorrect wiring. · Coil defect, contact failure.
			4) Breaking of wire	· Check for disconnected wire.
			5) Disconnected connector	· Check connector contacts.
			6) Problems with indoor unit controller (I.B1, I.B2)	* If no problems are found with the items above, the problem lies in the board.

Check code		Meaning, detecting method	Cause	Checking method & Countermeasure
4115	Power supply sync signal abnormality	The frequency cannot be determined when the power is switched on. (The power supply's frequency cannot be detected. The outdoor fan cannot be controlled by phase control.)	1) There is an open phase in the power supply (L1, L2, L3, N).	Check before the breaker, after the breaker or at the power supply terminal blocks TB1A, and if there is an open phase, correct the connections.
			2) The power supply voltage is distorted.	If the power supply voltage waveform is distorted from a sine wave, improve the power supply environment.
			3) A fuse is defective.	If F1 on the MAIN board, or F3 is melted, (Resistance between both ends of the fuse is ∞), replace the fuses.
			4) T01 is defective.	To judge failure of the T01, go to "Individual Parts Failure Judgment Methods."
			5) The circuit board is defective.	If none of the items in 1) to 4) is applicable, and if the trouble reappears even after the power is switched on again, replace the MAIN board (when replacing the circuit board, be sure to connect all the connectors, ground wires, etc. securely).
4200	VDC sensor/circuit abnormality	① If $VDC \leq 304 V$ is detected just before the inverter starts. ② If $VDC \geq 750 V$ is detected just before starting of and during operation of the inverter.	1) Power supply voltage is abnormal.	<ul style="list-style-type: none"> Check if an instantaneous power failure or power failure, etc. has occurred. Check if the voltage is the rated voltage value.
			2) The wiring is defective.	Check 1, the connections, 2, contact at the connectors, 3 tightening torque at screw tightened portions, 4, wiring polarities, 5, for broken wires, and 6, for grounding in the following wiring. TB1A~NF~TB1B, TB1B~DS~[52C, R1, R5]~[C2, C3]~IPM Wiring CNDC1 (G / A) ~ CNVDC (INV) Wiring * Check if the wiring polarities are as shown on the wiring diagram plate.
			3) The rush current prevention resistors (R1, 5) are defective.	To judge failure of R1 and R5, go to "Individual Parts Failure Judgment Methods."
			4) The electromagnetic contactor (52C) is defective.	To judge failure of the 52C, go to "Individual Parts Failure Judgment Methods."
			5) The diode stack (DS) is defective.	To judge failure of the DS, go to "Individual Parts Failure Judgment Methods."
			6) The reactor (DCL) is defective.	To judge failure of the DCL, go to "Individual Parts Failure Judgment Methods."
			7) The INV board is defective.	If none of the items in 1) to 6) is applicable, and if the trouble reappears even after the power is switched on again, replace the INV board (when replacing the circuit board, be sure to connect all the connectors, ground wires, etc. securely).

Check code	Meaning, detecting method	Cause	Checking method & Countermeasure	
4220	Bus voltage abnormality	If $VDC \leq 400$ V is detected during inverter operation.	1) The power supply voltage is abnormal.	<ul style="list-style-type: none"> Check if an instantaneous stop or power failure, etc. has occurred. Check if the voltage is the rated voltage value.
			2) The wiring is defective.	Check 1, the connections, 2, contact at the connectors, 3 tightening torque at screw tightened portions, 4, wiring polarities, 5, for broken wires, and 6, for grounding in the following wiring. TB1A~NF~TB1B, TB1B~DS~[52C, R1, R5]~[C2, C3]~IPM Wiring CNDC1 (G / A) ~ CNVDC (INV) Wiring * Check if the wiring polarities are as shown on the wiring diagram plate.
			3) The rush current prevention resistors (R1, 5) are defective.	To judge failure of R1 and R5, go to "Individual Parts Failure Judgment Methods."
			4) The electromagnetic contactor (52C) is defective.	To judge failure of the 52 C, go to "Individual Parts Failure Judgment Methods."
			5) The diode stack (DS) is defective.	To judge failure of the DS, go to "Individual Parts Failure Judgment Methods."
			6) The reactor (DCL) is defective.	To judge failure of the DCL, go to "Individual Parts Failure Judgment Methods."
			7) The inverter output is grounded.	<ul style="list-style-type: none"> Check the wiring between the IPM and the compressor. Check the compressor's insulation resistance.
			8) The IPM is defective.	Check the IPM. Judge that the IPM is faulty, (Go to "Individual Parts Failure Judgment Methods.")
			9) The circuit board is defective.	If none of the items in 1) to 8) is applicable, and if the trouble reappears even after the power is switched on again, replace the circuit board by following procedure (when replacing the circuit board, be sure to connect all the connectors, ground wires, etc. security) ① If the problem is solved after the G/A board only is replaced, then the G/A board is defective. ② If the problem is not solved, reinstall the G/A board and replace the INV board. If the problem is solved, the INV board is defective. ③ If the problem is not solved by ① and ② above, replace both boards.
4230	Radiator panel overheat protection	If the cooling fan stays ON for 5 minutes or longer during inverter operation, and if THHS $\geq 100^{\circ}\text{C}$ is detected.	1) The wiring is defective.	Check 1 connections, 2 contact at the connectors and 3 for broken wires in the following wiring. MF1~CNFAN
			2) The INV board's fuse (F01) is defective.	If the fuse is defective, replace the fuse.
			3) The cooling fan (MF1) is defective.	To judge failure of the MF1, go to "Individual Parts Failure Judgment Methods."
			4) The THHS sensor is defective.	To judge failure of the THHS, go to error code "5110".
			5) The air passage is clogged.	If the air passage of the heat sink is clogged, clear the air passage.
			6) The IPM is defective.	Check the IPM. Judge that the IPM is faulty, (Go to "Individual Parts Failure Judgment Methods.")
			7) The circuit board is defective.	If none of the items in 1) to 6) is applicable, and if the trouble reappears even after the power is switched on again, replace the circuit board by following procedure (when replacing the circuit board, be sure to connect all the connectors, ground wires, etc. security) ① If the problem is solved after the G/A board only is replaced, then the G/A board is defective. ② If the problem is not solved, reinstall the G/A board and replace the INV board. If the problem is solved, the INV board is defective. ③ If the problem is not solved by ① and ② above, replace both boards.

Check code	Meaning, detecting method	Cause	Checking method & Countermeasure
4240	Over load protection If IAC \geq 32 Amps is detected continuously for 10 minutes during operation of the inverter after 5 or more seconds have passed since the inverter started.	1) Air passage short cycle.	Is the unit's exhaust short cycling?
		2) The heat exchanger is clogged.	Clean the heat exchanger.
		3) Power supply voltage.	If the power supply voltage is less than 342 V, it is outside specifications.
		4) External air temperature.	If the external air temperature is over 43°C it is outside the specifications.
		5) Capacity setting error.	<ul style="list-style-type: none"> Is the indoor unit capacity total correct? Are the outdoor/indoor unit capacity settings correct?
		6) The solenoid valves (SV1, 2) are defective, or the solenoid valve drive circuit is defective.	To judge failure of the solenoid valve, go to "Individual Parts Failure Judgment Methods" for the "Solenoid Valve."
		7) The wiring is defective.	Check 1 connections, 2 contact at the connectors and 3 for broken wires in the following wiring. TB1A~NF~TB1B TB1B~FANCON board~CN04 CNMF~MF TB1B~CNTR1 CNFC1~CNFC2
		8) Fan motor (MF) operation is defective.	Go to "Treating Fan Motor Related Trouble."
		9) The inverter/compressor is defective.	Go to "Treating Inverter/Compressor Related Trouble."
4250	IPM alarm output / Bus voltage abnormality ① If over current, overheat or undervoltage of drive circuit is detected by IPM during inverter operation. [Inverter error detail : 1] ② If VDC \leq 300 or VDC \geq 760V is detected during inverter operation. [Inverter error detail : 1] ③ If IAC \geq 39Amps is detected during inverter operation. [Inverter error detail : 11]	1) The power supply voltage is abnormal.	<ul style="list-style-type: none"> Check if an instantaneous stop or power failure, etc. has occurred. Check if the voltage is the rated voltage value.
		2) The wiring is defective.	Check 1, the connections, 2, contact at the connectors, 3 tightening torque at screw tightened portions, 4, wiring polarities, 5, for broken wires, and 6, for grounding in the following wiring. TB1A~NF~TB1B, TB1A~DS-[52C, R1, R5]~[C2, C3]~IPM Wiring CNDC1 (G / A) ~ CNVDC (INV) Wiring * Check if the wiring polarities are as shown on the wiring diagram plate.
		3) The inverter / compressor is defective.	Go to "Treatment of Inverter/Output Related Trouble."

Check code	Meaning, detecting method	Cause	Checking method & Countermeasure
4260	Cooling fan abnormality If the heat sink temperature (THHS) $\geq 100^{\circ}\text{C}$ for 20 minutes or longer just before the inverter starts.	1) Same as "4230."	Same as "4230."
5101	Outdoor unit Discharge (TH1) Indoor unit Air inlet (TH21)	1) Thermistor 2) Lead wires are being pinched. 3) Insulation is torn. 4) A connector pin is missing, or there is faulty contact.	Check the thermistor's resistance. Check if the lead wires are pinched. Check for tearing of the insulation. Check if a pin is missing on the connector.
5102	Outdoor unit Low pressure saturation (TH2) Indoor unit Liquid pipe (TH22)	5) A wire is disconnected. 6) The thermistor input circuit on the MAIN circuit board is faulty. (In the case of the THHS, replace the INV board.)	Check if a wire is disconnected. Check the temperature picked up by the sensor using the LED monitor. If the deviation from the actual temperature is great, replace the MAIN circuit board. (In the case of the THHS, replace the INV board.)
5103	Outdoor unit Detected switch liquid level (LD1) Indoor unit Gas pipe (TH23)	④ The above short or open circuit is not detected for 10 minutes after the compressor starts, or for 3 minutes during defrosting or after recovery following defrosting. <THHS>	Short Circuit Detection Open Circuit Detection
5104	Outdoor unit Detected switch liquid level (LD2) Indoor unit Air outlet (TH24)	If a heat sink (THHS) temperature of $\leq -40^{\circ}\text{C}$ is detected just after the inverter starts or during inverter operation.	<Outdoor unit> TH1 240°C or higher (0.57 kΩ) 15°C or lower (321 kΩ) TH2 70°C or higher (1.71 kΩ) -40°C or lower (130 kΩ) LD1 - -40°C or lower (130 kΩ) LD2 - -40°C or lower (130 kΩ) TH5 110°C or higher (0.4 kΩ) -40°C or lower (130 kΩ) TH6 110°C or higher (0.4 kΩ) -40°C or lower (130 kΩ) TH7 110°C or higher (1.14 kΩ) -40°C or lower (130 kΩ) TH8 70°C or higher (1.14 kΩ) -40°C or lower (130 kΩ) TH9 70°C or higher (1.14 kΩ) -40°C or lower (130 kΩ) THHS - -40°C or lower (2.5 MΩ) TH10 240°C or higher (0.57 kΩ) -15°C or lower (1656 kΩ) <Indoor unit> TH21 90°C or higher (0.7kΩ) -40°C or lower (130 kΩ) TH22 90°C or higher (0.7kΩ) -40°C or lower (130 kΩ) TH23 90°C or higher (0.7kΩ) -40°C or lower (130 kΩ) TH24 90°C or higher (0.7kΩ) -40°C or lower (130 kΩ)
5105	Heat exchanger inlet pipe (TH5)		
5106	Ambient temperature (TH6)		
5107	Heat exchanger outlet pipe (TH7)		
5108	SC coil bypass outlet (TH8)		
5109	CS circuit (TH9)		
5110	Radiator panel (TH HS)		
5112	Compressor shell temperature (TH10)		

Check code	Meaning, detecting method	Cause	Checking method & Countermeasure	
5201	Pressure sensor abnormality	① When pressure sensor detects 0.098MPa or less during operation, outdoor unit once stops with 3 minutes restarting mode, and restarts if the detected pressure of pressure sensor exceeds 0.098MPa immediately before restarting. ② If the detected pressure of sensor is less than 0.098MPa immediately before restarting, error stop is commenced displaying 5201. ③ Under 3 minutes restarting mode, LED displays intermittent fault check. ④ During 3 minutes after compressor start, defrosting and 3 minutes after defrosting operations, trouble detection is ignored.	1) Pressure sensor trouble. 2) Inner pressure drop due to a leakage. 3) Broken cover. 4) Coming off of pin at connector portion, poor contact. 5) Broken wire. 6) Faulty thermistor input circuit of MAIN board.	See Troubleshooting of pressure sensor .
5301	IAC sensor/circuit abnormality	① If $IAC \geq 3Amps$ is detected just before the inverter starts, or If $IAC \leq 3Amps$ is detected during inverter operation after 5 seconds has passed since the inverter started when the INV board's SW1-1 is OFF. [Inverter error detail : 6] ② If the current sensor (ACCT) miss-wiring is detected during inverter operation. [Inverter error detail : 13]	1) Contact is faulty. 2) The current sensor (ACCT) is connected with wrong polarity. 3) The wiring is defective 4) The Ac current sensor (ACCT) is defective. 5) The IPM is defective.	Check the contacts of CNACCT on the INV board. Check the ACCT_U, W polarity with below drawing. Check 1. connections. 2. contact at the connectors. 3. for broken wires in the following wiring. CNDR2-CNDR1 CN15V2-CN15V1 IPM-MC1 To judge failure of ACCT, go to "Individual Parts Failure Judgment Methods." Check the IPM. Judge that the IPM is faulty, (Go to "Individual Parts Failure Judgment Methods.")

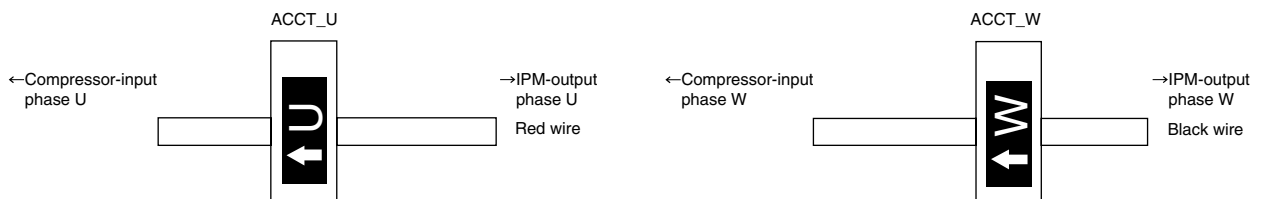

Check code	Meaning, detecting method	Cause	Checking method & Countermeasure
5301	IAC sensor/ circuit abnormality	① If IAC \geq 3Amps is detected just before the inverter starts, or If IAC \leq 3Amps is detected during inverter operation after 5 seconds has passed since the inverter started when the INV board's SW1-1 is OFF. [Inverter error detail : 6] ② If the current sensor (ACCT) miss-wiring is detected during inverter operation. [Inverter error detail : 13]	6) The circuit board is defective. If none of the items in 1) to 5) is applicable, and if the trouble reappears even after the power is switched on again, replace the circuit board by following procedure (when replacing the circuit board, be sure to connect all the connectors, ground wires, etc. securely) ① If the problem is solved after the G/A board only is replaced, then the G/A board is defective. ② If the problem is not solved, reinstall the INV board and replace the INV board. If the problem is solved, the INV board is defective. ③ If the problem is not solved by ① and ② above, replace both boards.
7130	Different indoor model connected abnormality	An exclusive R22 refrigerant indoor unit was connected to a R407C refrigerant outdoor unit.	1) An error was made in the MAIN board of the outdoor unit (replaced with the wrong circuit board). 2) An error was made in selecting the indoor unit (installation error). 3) An error was made in the indoor unit's circuit board (replaced with the wrong circuit board).

[2] Communication / System

Check code	Meaning, detecting method	Cause	Checking method & Countermeasure
6600	Multiple address error Transmission from units with the same address is detected. <div style="border: 1px solid black; padding: 5px; width: fit-content;">Note: The address/attribute shown on remote controller indicates the controller which has detected error.</div>	1) Two or more controllers of outdoor unit, indoor unit, remote controller, BC controller, etc. have the same address. 2) In the case that signal has changed due to noise entered into the transmission signal.	At the generation of 6600 error, release the error by remote controller (with stop key) and start again. a) If the error occurs again within 5 minutes. → Search for the unit which has the same address with that of the source of the trouble. <div style="border: 1px solid black; padding: 5px; width: fit-content;">When the same address is found, turn off the power source of outdoor unit, BC controller, and indoor unit for 5 minutes or more after modifying the address, and then turn on it again.</div> b) When no trouble is generated even continuing operation over 5 minutes. → The transmission wave shape/noise on the transmission line should be investigated in accordance with <Investigation method of transmission wave shape/noise>.
6602	Transmission processor hardware error Though transmission processor intends to transmit "0", "1" is displayed on transmission line. <div style="border: 1px solid black; padding: 5px; width: fit-content;">Note: The address/attribute shown on remote controller indicates the controller which has detected error.</div>	1) At the collision of mutual transmission data generated during the wiring work or polarity change of the transmission line of indoor or outdoor unit while turning the power source on, the wave shape is changed and the error is detected. 2) 100V power source connection to indoor unit or BC controller. 3) Ground fault of transmission line. 4) Insertion of power supply connector (CN40) of plural outdoor units at the grouping of plural refrigerant systems. 5) Insertion of power supply connector (CN40) of plural outdoor units in the connection system with MELANS. 6) Faulty controller of unit in trouble. 7) Change of transmission data due to the noise in transmission. 8) Connection system with plural refrigerant systems or MELANS for which voltage is not applied on the transmission line for central control.	

Check code	Meaning, detecting method	Cause	Checking method & Countermeasure
6602	Transmission processor hardware error	Checking method and processing	
6603	Transmission circuit bus-busy error 1 Collision of data transmission: Transmission can not be performed for 4~10 consecutive minutes due to collision of data transmission. 2 Data can not be transmitted on transmission line due to noise for 4~10 consecutive minutes. <div style="border: 1px solid black; padding: 5px; width: fit-content;"> Note: The address/attribute shown on remote controller indicates the controller which has detected error. </div>	1) As the voltage of short frequency like noise is mixed in transmission line continuously, transmission processor can not transmit. 2) Faulty controller of generating unit.	a) Check transmission wave shape/noise on transmission line by following <Investigation method of transmission wave shape/noise>. → No noise indicates faulty controller of generating unit. → Noise if existed, check the noise.

Check code	Meaning, detecting method	Cause	Checking method & Countermeasure		
6606	<p>Communications with transmission processor error</p> <p>Communication trouble between apparatus processor and transmission processor.</p> <div style="border: 1px solid black; padding: 5px; margin-top: 10px;"> <p>Note: The address/attribute shown on remote controller indicates the controller which has detected error.</p> </div>	<p>1) Data is not properly transmitted due to casual erroneous operation of the generating controller.</p> <p>2) Faulty generating controller.</p>	<p>Turn off power sources of indoor unit, BC controller and outdoor unit.</p> <p>(When power sources are turned off separately, microcomputer is not reset and normal operations can not be restored.)</p> <p>→ Controller trouble is the source of the trouble when the same trouble is observed again.</p>		
Check code	Meaning, detecting method				
6607	<p>No ACK error</p> <p>When no ACK signal is detected in 6 continuous times with 30 second interval by transmission side controller, the transmission side detects error.</p> <div style="border: 1px solid black; padding: 5px; margin-top: 10px;"> <p>Note: The address/attribute shown on remote controller indicates the controller not providing the answer (ACK).</p> </div>				
System composition	Generating unit address	Display of trouble	Detecting method	Cause	Checking method & countermeasure
(1) Single refrigerant system	① Outdoor unit (OC)	Remote controller (RC)	No reply (ACK) at IC transmission to OC	<p>1) Poor contact of transmission line of OC.</p> <p>2) Damping of transmission line voltage/signal by acceptable range of transmission wiring exceeded.</p> <div style="border: 1px solid black; padding: 2px; margin: 5px 0;"> <p>Farthest : Less than 200m Remote controller wiring : Less than 10m</p> </div> <p>3) Erroneous sizing of transmission line (Not within the range below). Wire diameter : 1.25mm² or more</p> <p>4) Faulty control circuit board of OC.</p>	<p>Shut down OC unit power source, and make it again. It will return to normal state at an accidental case. When normal state can not be recovered, check for the 1) ~ 4) of the cause.</p>
	② Indoor unit (IC)	Remote controller (RC)	No reply (ACK) at RC transmission to IC	<p>1) When IC unit address is changed or modified during operation.</p> <p>2) Faulty or slipping off of transmission wiring of IC.</p> <p>3) Slipping off of IC unit connector (CN2M).</p> <p>4) Faulty IC unit controller.</p> <p>5) Faulty remote controller.</p>	<p>Shut down OC power source simultaneously for 5 minutes or more, and make them again. It will return to normal state at an accidental case. When normal state can not be recovered, check for the 1) ~ 4) of the cause.</p>
	③ Remote controller (RC)	Remote controller (RC)	No reply (ACK) at IC transmission to RC	<p>1) Faulty transmission wiring at IC unit side.</p> <p>2) Faulty transmission wiring of RC.</p> <p>3) When remote controller address is changed or modified during operation.</p> <p>4) Faulty remote controller.</p>	<p>Shut down OC power sources for 5 minutes or more, and make it again. It will return to normal state at an accidental case. When normal state can not be recovered, check for the 1) ~ 4) of the cause.</p>

Check code	Meaning, detecting method				
6607 (continued)	No ACK error		When no ACK signal is detected in 6 continuous times with 30 second interval by transmission side controller, the transmission side detects error.		
<div style="border: 1px solid black; padding: 5px; display: inline-block;"> Note: The address/attribute shown on remote controller indicates the controller not providing the answer (ACK). </div>					
System composition	Generating unit address	Display of trouble	Detecting method	Cause	Checking method & countermeasure
(2) Group operation system using plural refrigerants	① Outdoor unit (OC)	Remote controller (RC)	No reply (ACK) at BC transmission to OC	As same that for single refrigerant system.	Same as measure for single refrigerant system.
	② Indoor unit (IC)	Remote controller (RC)	No reply (ACK) at RC transmission to IC	1) Cause of 1) ~ 5) of "Cause for single refrigerant system". 2) Slipping off or short circuit of transmission line of OC terminal block for centralized control (TB7). 3) Shut down of OC unit power source of one re-frigerant system. 4) Neglecting insertion of OC unit power supply connector (CN40). 5) Inserting more than 2 sets of power supply connector (CN40) for centralized control use. For generation after normal operation conducted once, the following causes can be considered. <ul style="list-style-type: none"> • Total capacity error (7100) • Capacity code setting error (7101) • Connecting set number error (7102) • Address setting error (7105) 	a) Shut down the power source of both IC and OC for over 5 minutes simultaneously, and make them again. Normal state will be returned incase of accidental trouble. b) Check for 1) ~ 5) of causes. If cause is found, remedy it. c) Check other remote controller or OC unit LED for troubleshooting for trouble. Trouble → Modify the trouble according to the content of check code. No trouble → Faulty indoor controller
	③ Remote controller (RC)	Remote controller (RC)	No reply (ACK) at IC transmission to RC	1) Cause of 1) ~ 3) of "Cause for single refrigerant system". 2) Slipping off or short circuit of transmission line of OC terminal block for centralized control (TB7). 3) Shut down of OC unit power source of one refrigerant system. 4) Neglecting insertion of OC unit power supply connector (CN40). 5) Inserting more than 2 sets of power supply connector(CN40) for centralized control use. At generation after normal operation conducted once, the following causes can be considered. <ul style="list-style-type: none"> • Total capacity error (7100) • Capacity code setting error (7101) • Connecting set number error (7102) • Address setting error (7105) 	a) Shut down the power source of OC for over 5 minute, and make it again. Normal state will be returned in case of accidental trouble. b) Check for 1) ~ 5) of causes. If cause is found, remedy it. When normal state can not be obtained, check 1) ~ 5) of causes.

Check code	Meaning, detecting method				
6607 (continued)	No ACK error		When no ACK signal is detected in 6 continuous times with 30 second interval by transmission side controller, the transmission side detects error.		
<div style="border: 1px solid black; padding: 5px; width: fit-content; margin: 0 auto;"> Note: The address/attribute shown on remote controller indicates the controller not providing the answer (ACK). </div>					
System composition	Generating unit address	Display of trouble	Detecting method	Cause	Checking method & countermeasure
(3) Connecting system with system controller (MELANS)	① Outdoor unit (OC)	Remote controller (RC)	No reply (ACK) at IC transmission to OC	As same that for single refrigerant system.	Same countermeasure as that for single refrigerant system.
	② Indoor unit (IC)	Remote controller (RC)	No reply (ACK) at transmission of SC to IC	Trouble of partial IC units: 1) Same cause as that for single refrigerant system.	→ Same countermeasure as that for single refrigerant system.
				Trouble of all IC in one refrigerant system: 1) Cause of total capacity error. (7100) 2) Cause of capacity code setting error. (7101) 3) Cause of connecting number error. (7102) 4) Cause of address setting error. (7105) 5) Slipping off or short circuit of transmission line of OC unit terminal block for central control (TB7). 6) Power source shut down of OC unit. 7) Trouble of OC unit electrical system.	Confirm OC trouble diagnosis LED. → At trouble generation, check for the content according to check code. Check the content of 5)~7) shown left.
				Trouble of all IC: 1) As same that for single refrigerant system. 2) Insertion of power supply connector (CN40) into OC unit transmission line for centralized control. 3) Slipping off or power source shut down of power supply unit for transmission line. 4) Faulty system controller (MELANS).	Confirm voltage of transmission line for centralized control. • More than 20V → Confirm 1) 2) left. • Less than 20V → Confirm 3) left.
	③ Remote controller (RC)	Remote controller (RC)	No reply (ACK) at transmission of IC to RC	Same cause as that for plural refrigerant system.	Same countermeasure as that for plural refrigerant system.
				No reply (ACK) at transmission of MELANS to RC	Trouble of partial IC units: 1) Same cause of that for single refrigerant system.
Trouble of all IC in one refrigerant system: 1) Error detected by OC unit. Total capacity error. (7100) Capacity code setting error. (7101) Connecting number error. (7102) Address setting error. (7105) 2) Slipping off or short circuit of transmission line of OC unit terminal block for central control (TB7). 3) Power source shut down of OC unit. 4) Trouble of OC unit electrical system.					Confirm OC trouble diagnosis LED. → At trouble generation, check for the content according to check code. Check the content of 2)~4) shown left.
Trouble of all IC: 1) As same that for single refrigerant system. 2) Insertion of power supply connector (CN40) into OC unit transmission line for centralized control. 3) Slipping off or power shutdown of power supply unit for transmission line. 4) Faulty MELANS.	Check the causes of 1) ~ 4) left.				

Check code	Meaning, detecting method				
6607 (continued)	No ACK error		When no ACK signal is detected in 6 continuous times with 30 second interval by transmission side controller, the transmission side detects error.		
<div style="border: 1px solid black; padding: 5px; display: inline-block;"> Note: The address/attribute shown on remote controller indicates the controller not providing the answer (ACK). </div>					
System composition	Generating unit address	Display of trouble	Detecting method	Cause	Checking method & countermeasure
(3) Connecting system with system controller (MELANS)	⑤ System controller (SC)	Remote controller (RC)	No reply (ACK) at transmission of IC to SC	Trouble of partial remote controller: 1) Faulty wiring of RC transmission line. 2) Slipping off or poor contact of RC transmission connector. 3) Faulty RC.	Check 1) ~ 3) left.
				Trouble of all IC in one refrigerant system. 1) Error detected by OC unit. Total capacity error (7100) Capacity code setting error (7101) Connecting number error (7102) Address setting error (7105) 2) Slipping off or short circuit of transmission line of OC unit terminal block for central control (TB7). 3) Power source shut down of OC unit. 4) Trouble of OC unit electrical system.	Confirm OC trouble diagnosis LED. → At trouble generation, check for the content according to check code. Check the content of 2) ~ 4) shown left.
				Trouble of all RC: 1) As same that for single refrigerant system. 2) Inserting supply power connector (CN40) to OC transmission line for centralized control. 3) Slipping off or power shutdown of power supply unit for transmission line. 4) Faulty MELANS.	Check the causes 1)~4) left.
No relation with system	Address which should not be existed	-	-	1) IC unit is keeping the memory of the original group setting with RC although the RC address was changed later. The same symptom will appear for the registration with SC. 2) IC unit is keeping the memory of the original interlocking registration with Fresh Master with RC although the Fresh Master address was changed later.	As some IC units are keeping the memory of the address not existing, delete the information. Employ one of the deleting method among two below. 1) Deletion by remote controller. Delete unnecessary information by the manual setting function of remote controller. 2) Deletion by connecting information deleting switch of OC unit. <div style="border: 1px solid black; padding: 5px; margin-top: 10px;"> Be careful that the use of this method will delete all the group information set with RC and all the interlocking information of Fresh Master and IC unit. </div> <ol style="list-style-type: none"> ① Shut down OC unit power source, and wait for 5 minutes. ② Turn on the dip switch SW2-2 provided on OC unit control circuit board. ③ Make OC unit power source, and wait for 5 minutes. ④ Shut down OC unit power source, and wait for 5 minutes. ⑤ Turn off the dip switch SW2-2 provided on OC unit control circuit board. ⑥ Make OC unit power source.

Check code	Meaning, detecting method	Cause	Checking method & Countermeasure
6608	<p>No response error</p> <p>Though acknowledgement of receipt (ACK) is received after transmission, no response command is returned.</p> <p>Detected as error by transmission side when the same symptom is re-peated 10 times with an interval of 3 seconds.</p> <div style="border: 1px solid black; padding: 5px; margin-top: 10px;"> <p>Note: The address/attribute shown on remote controller indicates the controller which has detected error.</p> </div>	<ol style="list-style-type: none"> 1) At the collision of mutual transmission data when transmission wiring is modified or the polarity is changed while turning the power source on, the wave shape changes detecting error. 2) Repeating of transmission error due to noise. 3) Damping of transmission line voltage/signal due to exceeding of the acceptable range for transmission wiring. <ul style="list-style-type: none"> • Farthest Less than 200m • RC wiring Less than 12m 4) Damping of transmission voltage/signal due to improper type of transmission line. <ul style="list-style-type: none"> • Wire size : More than 1.25mm² 	<ol style="list-style-type: none"> a) Generation at test run. Turn off the power sources of OC unit, IC unit and Fresh Master for more than 5 minutes simultaneously, and make them again. → Returning to normal state means the trouble detection due to transmission line work while powering. b) Check 3) and 4) of the causes left. c) Investigate the transmission wave shape/noise on transmission line according to <Investigation method of transmission wave shape/noise>. <div style="border: 1px solid black; border-radius: 10px; padding: 5px; margin-top: 10px; text-align: center;"> <p>Much possibility if 6602 is generated.</p> </div>

[3] System error

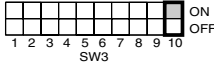
Check code	Meaning, detecting method	Cause	Checking method & Countermeasure				
7100	Total capacity error Total capacity of indoor units in the same refrigerant system exceeds limitations. <div style="border: 1px solid black; padding: 5px; width: fit-content; margin: 10px auto;"> Trouble source: Outdoor unit </div>	1) Total capacity of indoor units in the same refrigerant system exceeds the following: <table border="1" style="margin: 10px auto;"> <thead> <tr> <th>Total capacity</th> <th>Total capacity code</th> </tr> </thead> <tbody> <tr> <td style="text-align: center;">325</td> <td style="text-align: center;">65</td> </tr> </tbody> </table>	Total capacity	Total capacity code	325	65	a) Check for the model total (capacity cord total) of indoor units connected. b) Check whether indoor unit capacity code (SW2) is wrongly set. For erroneous switch setting, modify it, turn off power source of outdoor unit, and indoor unit simultaneously for 5 minutes or more to modify the switch for setting the model name (capacity load).
		Total capacity	Total capacity code				
325	65						
2) Erroneous setting of OC model selector switch (SW3-10). 	Check for the model selector switch (Dip switches SW3-10 on outdoor unit control circuit) of OC.						
6831	MA communication no-reception error Problem with the communication between MA remote controllers and indoor units No instance of successful reception of data in a 3-minute period.	1) Contact failure of MA remote controller or indoor unit remote controller wiring. 2) All the remote controllers are set to "Sub". 3) Failure to meet wiring specifications ① Wire length ② Wire diameter ③ Number of remote controllers ④ Number of indoor units	a) Check for loose or disconnected indoor unit or MA remote controller transmission lines. b) Confirm that the power is fed to main power supply and remote controller line. c) Confirm that MA remote controller's maximum capacity is not exceeded. d) Check the Main/Sub setting of the MA remote controller; one of must be set to sub. e) Diagnose the remote controller (described on the remote controller IM) Results [OK] : No problems with the remote controller (check the wiring rules) [NO] : Replace the remote controller [6832, 6833, ERROR] : Noise interference (Go to item f))				
6834	MA communication, start but detection error Problem with the communication between MA remote controllers and indoor units. No instance of successful reception of signals in a 2-minute period.	4) Remote controller was connected and then removed without power reset. 5) Noise interference on the remote controller transmission channel. 6) Problems with the remote controller transmission/reception circuit in the indoor unit. 7) Problems with the transmission/reception circuit in the remote controller.	f) Check the transmission wave patterns of and interference in the MA remote controller transmission signal. Refer to section 4 Transmission Wave Pattern and Noise Check. g) When no problems were found in items a) through f), replace the indoor controller board or the MA remote controller The following information can be obtained from LED1 and 2 on the indoor controller board: LED1 is on : Main switch of the indoor unit is on. LED2 is on : MA remote controller line is being powered.				
6832	MA communication, sync restoration error Problem with the communication between MA remote controllers and indoor units. Failure to detect opening in the transmission path and the signal could not be sent. Indoor unit: for 3 minutes Remote controller: for 6 minutes	1) Contact failure of MA remote controller or indoor unit remote controller wiring. 2) More than 1 "Main" remote controller 3) Multiple indoor unit address 4) Noise interference in the remote controller line. 5) Failure to meet wiring specifications. ① Wire length ② Wire diameter ③ Number of remote controllers ④ Number of indoor units					
6833	MA communication, transmission-reception H/W error Problem with the communication between MA remote controllers and indoor units. Then transmitted data and received data that are collected at the same time differs 30 times in a row.	6) Problems with the transmission/reception circuit in the remote controller.					

Check code	Meaning, detecting method	Cause	Checking method & Countermeasure				
7101	<p>Capacity code error</p> <p>Error display at erroneous connection of Indoor unit of which model name can not be connected.</p> <p>Trouble source : Outdoor unit Indoor unit</p>	<ol style="list-style-type: none"> 1) The Indoor unit model name (model code) connected is not connectable. Connectable range.....20~250 2) Erroneous setting of the switch (SW2) for setting of model name of Indoor unit connected. 	<ol style="list-style-type: none"> a) Check for the model name of the Indoor unit connected. b) Check for the switch (SW2 if indoor controller for setting of Indoor unit model name of generating address. When it is not agreed to the model name, modify the capacity code while shutting off the power source of Indoor unit. <p>*: The capacity of Indoor unit can be confirmed by the self-diagnosis function (SW1 operation) of Indoor unit.</p>				
7102	<p>Connected unit count over</p> <p>Number of units connected in the same refrigerant system exceeds limitations.</p> <p>Trouble source: Outdoor unit</p>	<ol style="list-style-type: none"> 1) Number of unit connected to terminal block (TB3) for outdoor/indoor transmission line exceeds limitations given be-lows: <table border="1" style="margin-left: 20px;"> <thead> <tr> <th>Item</th> <th>Limitation</th> </tr> </thead> <tbody> <tr> <td>Total of Indoor unit</td> <td>1</td> </tr> </tbody> </table> 2) The Outdoor unit address is being set to 51~100 under automatic address mode (Remote controller displays "HO"). 3) Slipping off of transmission wiring at Outdoor unit. 4) Short circuit of transmission line in case of 3) & 4), remote controller displays "HO". 	Item	Limitation	Total of Indoor unit	1	<ol style="list-style-type: none"> a) Check whether the connection of units to the terminal block for indoor/outdoor transmission wiring (TB3) of outdoor unit is not exceeding the limitation. b) Check for 2), 3), and 4). c) Check for the connection of transmission wiring to the terminal block for centralized control erroneously connected to the indoor/outdoor transmission wiring terminal block (TB3). d) Check for the model total (capacity code total) of indoor units connected.
Item	Limitation						
Total of Indoor unit	1						
7105	<p>Address setting error</p> <ul style="list-style-type: none"> • Erroneous setting of OC unit address • Erroneous setting of BC controller address <p>Trouble source : Outdoor unit</p>	<ol style="list-style-type: none"> 1) Setting error of Outdoor unit address. The address of Outdoor unit is not being set to 51~100. 	<p>Check that the address of OC unit is being set to 51~100. Reset the address if it stays out of the range, while shutting the power source off. When BC controller is out of the range, reset it while shutting the power source of both OC unit off.</p>				
7110	<p>Indoor units cannot operate because they are not connected to the correct outdoor units in the same refrigerant circuit.</p>	<ol style="list-style-type: none"> 1) Power to the power supply extension unit for transmission line is shut off. 2) Power reset of the power supply extension unit for transmission line and outdoor unit. 	<ol style="list-style-type: none"> a) Confirm that the power supply to the power supply extension unit for transmission wire is not connected to the indoor unit's switch, thus cutting off the power. (The unit will not operate normally unless the power to the power supply extension unit for transmission line is turned on→power reset the outdoor unit.) 				
7111	<p>Remote control sensor error</p> <p>Error not providing the temperature designed to remote controller sensor.</p> <p>Trouble source : Indoor unit</p>	<ol style="list-style-type: none"> 1) In case when the old type remote controller for M-NET is used and the remote controller sensor is designed on indoor unit. (SW1-1 turned ON) 	<ol style="list-style-type: none"> a) Replace the old remote controller by the new remote controller. 				
7130	<p>Different Indoor model controller connected error</p>	<p>A indoor unit not for the R407C (model: P250/500) is connected.</p>	<p>Use the P250/500 indoor unit.</p>				

[4] Troubleshooting using information on problems with Remote Control, Input from External Source

(1) MA Remote Control

	Symptoms	Causes	Diagnostic Method and Remedy
1	There is no response when pressing Power ON on the remote controller (Power-on indicator © on the remote controller is off)	<ol style="list-style-type: none"> 1) No power is supplied to the indoor unit by the transformer <ol style="list-style-type: none"> ① Main switch of the indoor unit is off ② Connectors (CND, CNT, CN3T) on the indoor controller board are unplugged ③ Fuses on the indoor controller board are blown out ④ Transformer on the indoor unit is not working, Torn wires 2) MA remote controller line is wired incorrectly <ol style="list-style-type: none"> ① MA remote controller line is torn or disconnected from terminal board ② Short-circuited MA controller line ③ MA remote controller line is wired incorrectly ④ MA remote controller line is connected to TB5 ⑤ MA remote controller line is accidentally connected to AC 200V power-source line terminal ⑥ MA remote controller line is accidentally connected to M-NET Transmission line terminal in the indoor unit 3) More than the permissible number of remote controllers (2) are connected to the unit 4) The length or diameter of MA remote controller does not meet the specifications 5) Remote Display Output line on the indoor unit is short-circuited or the relays are connected with wrong polarities 6) Faulty indoor controller board 7) Problems with MA remote controller 	<ol style="list-style-type: none"> a) Check MA remote controller terminal voltage (between A and B) <ol style="list-style-type: none"> a. Voltage between DC9-12 → Problem with remote controller b. No voltage <ul style="list-style-type: none"> • Check items 1 and 3 on the left → Correct the problem if found. • If neither 1 nor 3 applies → Go to b) b) Disconnect the remote controller line from TB13 on the indoor unit, and check the voltage between A and B. <ol style="list-style-type: none"> a. Voltage between DC 9-12 → Check items 2) and 4) on the left. Correct the problem if found. b. No voltage <ul style="list-style-type: none"> • Check 1) on the left again. → Correct the problem if found. • If no problem is found with item 1), check Remote Display Line (i.e. polarity of the relay) • If still no problem is found, replace the indoor controller board.

2	Display on the LED remains for a few seconds then disappears when turning on power with the remote controller	<ol style="list-style-type: none"> 1) M-NET Transmission is powered by the outdoor unit <ol style="list-style-type: none"> ① Main switch on the outdoor unit is OFF. ② Connectors on the main board of the outdoor unit are unplugged Main controller board CNS1, CNVCC3 Inverter board CNDC2, CNVCC2, CNL2 Gate-amp terminal board CNDC1 ③ Faulty outdoor power supply circuit <ul style="list-style-type: none"> • Blown fuse on G/A board (F01) • Damaged diode stack • Faulty Inverter board • Surge breaker resistance (R1) loss 2) Shorted transmission line 3) Faulty wiring of M-NET transmission line on the outdoor unit <ol style="list-style-type: none"> ① Torn transmission line, disconnected line from terminal ② Indoor transmission line accidentally connected to TB7 4) Torn M-NET line on the indoor unit 5) Disconnected lines or unplugged connectors between M-NET transmission terminal (TB5) and Indoor controller board CN2M 	<div style="border: 1px solid black; padding: 5px; margin-bottom: 10px;"> <p>If one of the items 1)-5) on the left is the cause, LED5 (M-NET Transmission voltage indicator) on the indoor controller board will be off.</p> </div> <div style="border: 1px solid black; padding: 5px;"> <p>When 2) or 3) is the cause, error message 7102 will be displayed on the self-diagnosis LED on the outdoor unit.</p> </div>
---	---	--	--

< Diagnostic Method and Remedy >

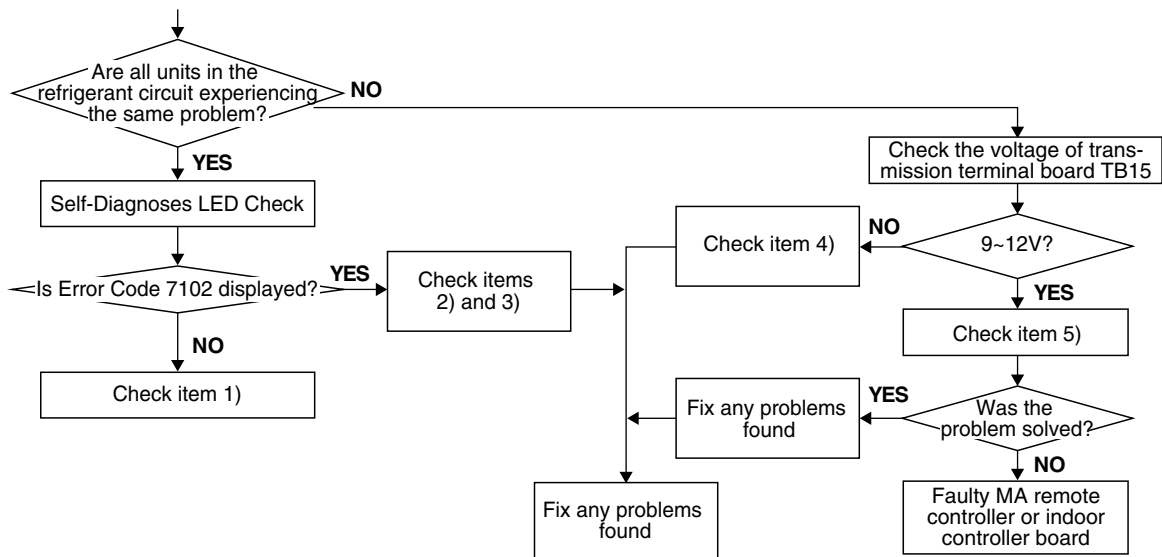

Symptoms	Causes	
<p>'HO' on the display cannot be turned off, and the switch does not respond.</p>	<ol style="list-style-type: none"> 1) M-NET Transmission is powered by the outdoor unit <ol style="list-style-type: none"> ① Main switch on the outdoor unit is off ② Connectors on the main board of the outdoor unit are unplugged Main controller board CNS1,CNVCC3 Inverter board CNDC2, CNVCC2, CNL2 Gate-amp terminal board CNDC1 ③ Faulty outdoor power supply circuit <ul style="list-style-type: none"> • Blown fuse on G/A board • Faulty Inverter board • Damaged diode stack • Surge breaker resistance (R1) Loss 2) Shorted transmission line 3) Faulty wiring of M-NET transmission line on the outdoor unit <ol style="list-style-type: none"> ① Torn transmission line, disconnected line from terminal ② Indoor transmission line is accidentally connected to TB7 4) Torn M-NET line on the indoor unit 5) Disconnected lines or unplugged connectors between M-NET transmission terminal (TB5) and Indoor controller board CN2M 6) MA remote controller line is wired incorrectly <ol style="list-style-type: none"> ① Short-circuited MA controller line ② MA remote controller line (No.2) is torn or disconnected from terminal board ③ Faulty wiring among grouped units. ④ MA remote controller line is accidentally connected to TB5 ⑤ M-NET transmission line is accidentally connected to TB15 7) A different address other than the indoor unit address +50 is used for the outdoor unit 8) The address of the indoor unit is set above 51 9) MA remote controller is set as subordinate 10) Faulty indoor controller board (MA remote controller communication circuit) 11) Faulty remote controller 	<div style="border: 1px solid black; padding: 5px; margin-bottom: 10px;"> <p>If one of the items 1)~4) is the cause of the problem, LED 5 on the indoor control board will be off.</p> </div> <div style="border: 1px solid black; padding: 5px;"> <p>If one of the items 2), 3), or 5) is the cause of the problem, Error Code 7102 will be displayed on the self-diagnosis LED on the outdoor unit.</p> </div>

3

< Diagnostic Method and Remedy >

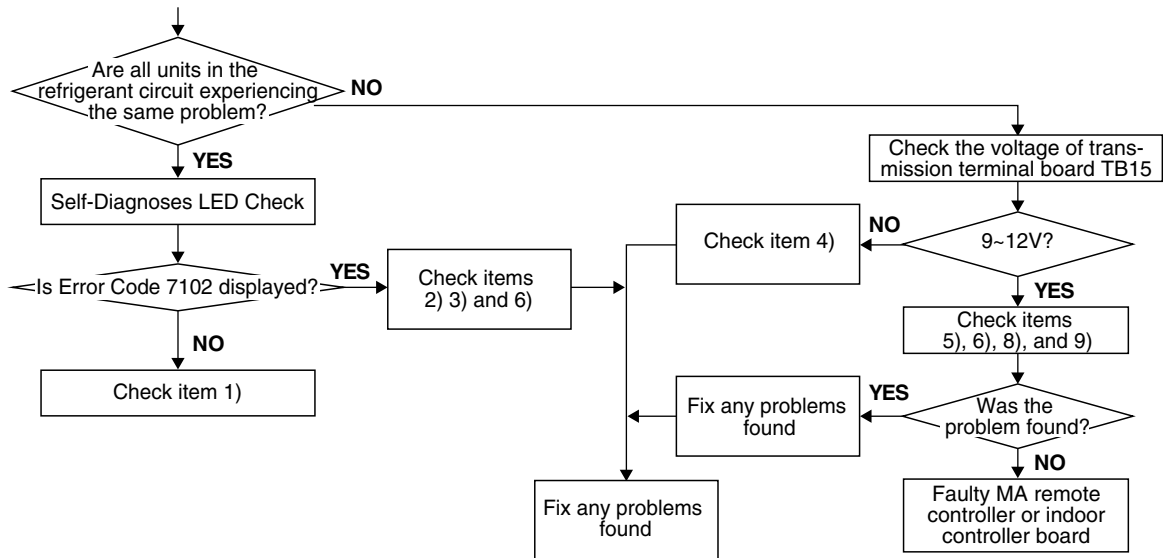

Flow chart: When MA remote controller does not respond.

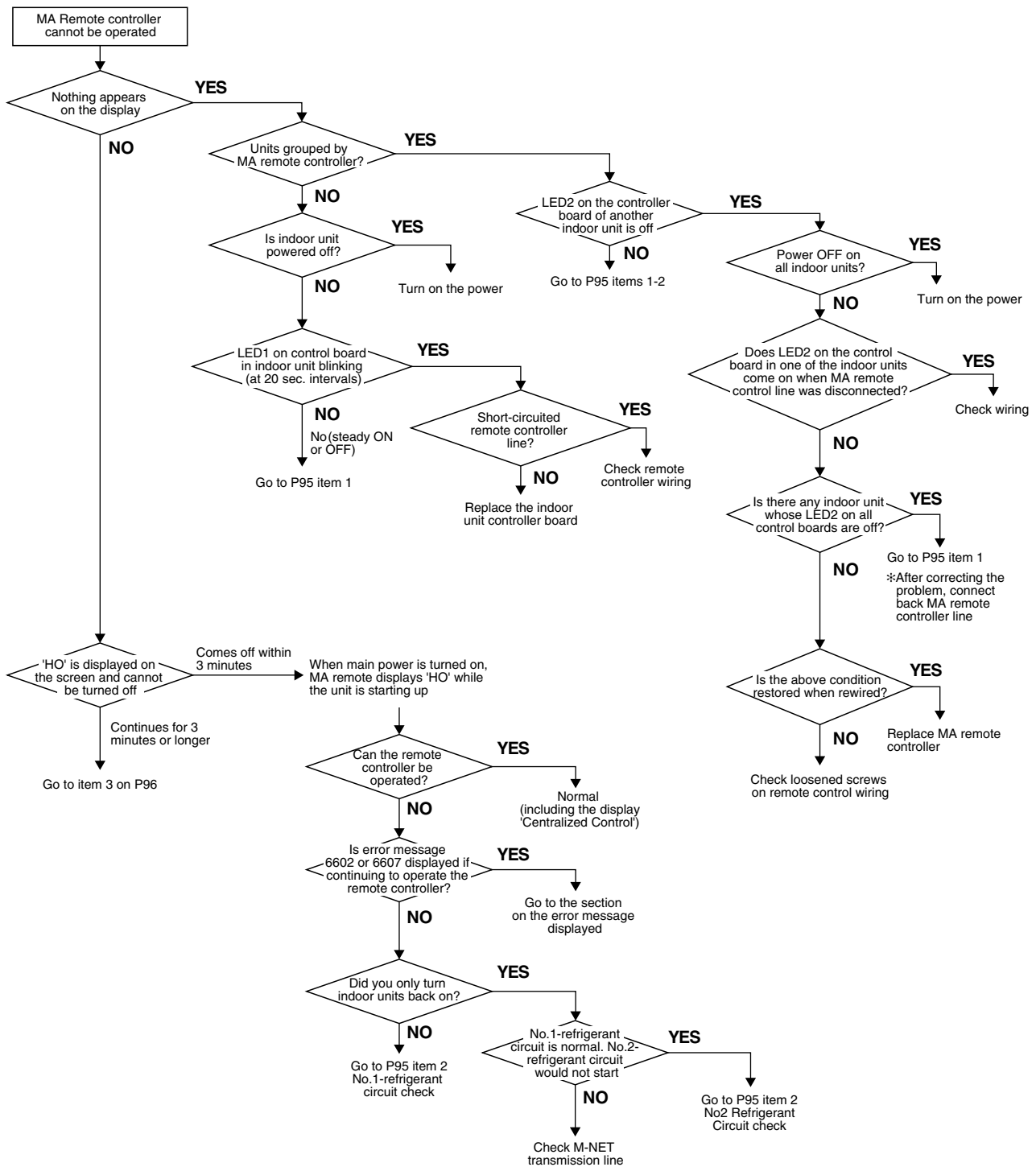

(2) Input from External Source

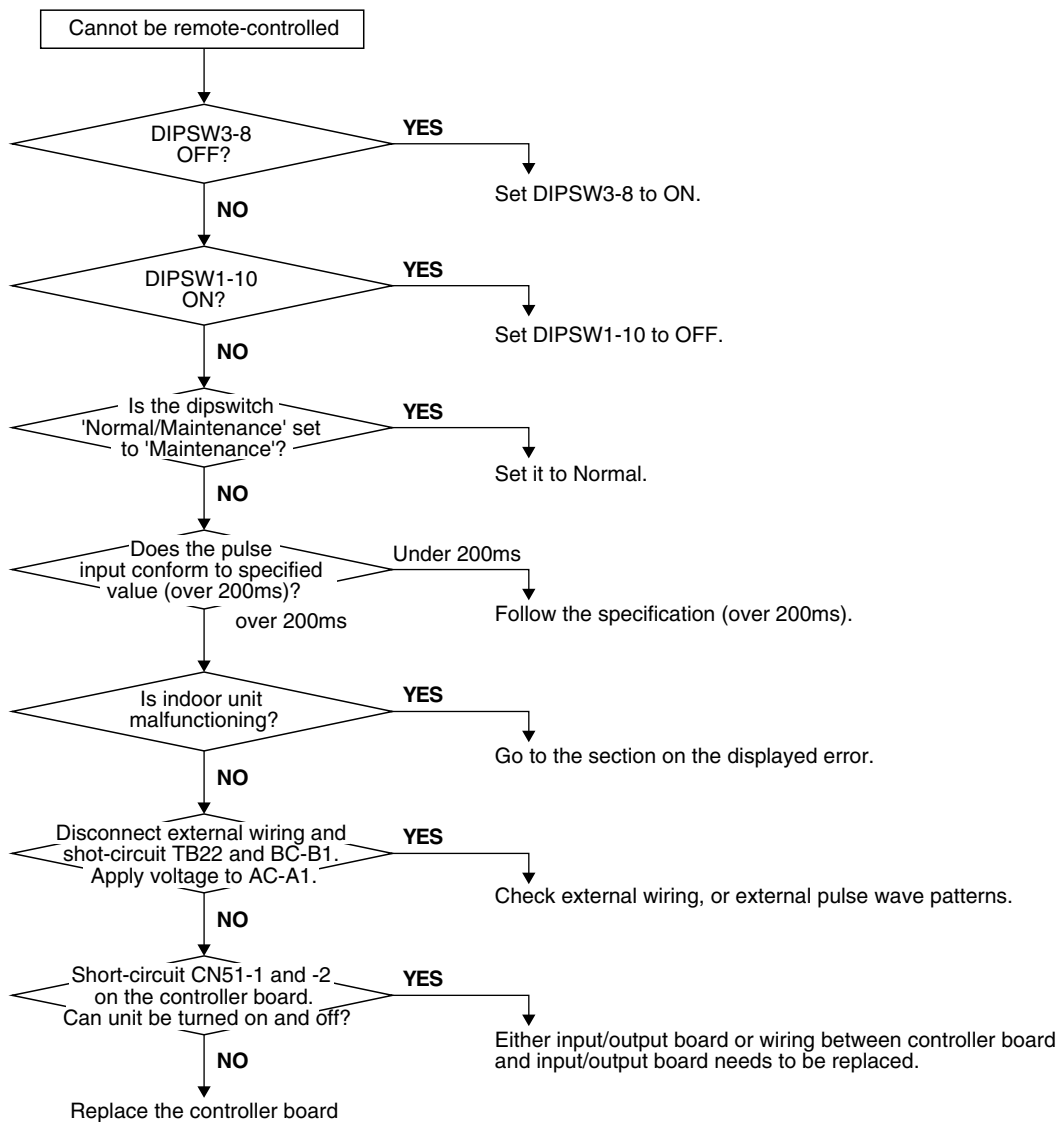

4 Transmission Wave Pattern and Noise Check

[1] M-NET Transmission

This series of air conditioning units is controlled by sending signals among centralized control, outdoor units, and indoor units. Noise entering transmission line interferes with normal signal transmission and causes malfunctions.

(1) Symptoms caused by noise

Cause	Symptoms	Error Codes	Definitions
Noise infiltration	Alters signals and they are mistaken for other address signals	6600	Multiple-Address Error
	Transmission wave patterns are changed.	6602	Transmission Processor H/W Error
	Wave patterns are changed and become unrecognizable and the receiving end of the signal becomes unable to respond.	6607	Non-acknowledgeable Signals Error
	Un-communicable state lasts due to fine noise.	6603	Transmission Circuit Bus-Busy Error
	Signals can be sent, but response cannot be sent or received.	6607 6608	Non-acknowledgeable Signals Error No Response Error

(2) Wave Pattern Check

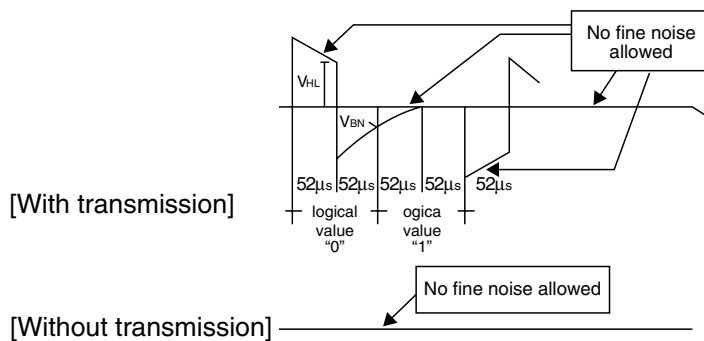

Check wave patterns in transmission line with an oscilloscope, and make sure that the following conditions are met:

- ① No fine wave patterns (noise) are found. Fine noises (around 1V) may be picked up when operating DC-DC converter or inverter. This noise will not cause problems if units and transmission line are shield-earthed.
- ② Voltage of transmission signals meet the following conditions:

Logical Value	Transmission line voltage
0	V _{H/L} over 2.0V
1	V _{B/N} over 1.3V

(3) Identifying noise source and remedying the problems

① Treatment of Noise

Check the following when noise is picked up or when error codes in section (1) are displayed on the LED.

	Check Points	Remedies
Wiring Check	① Make sure that transmission line and power-supply line are not cross-connected	Place transmission wire as far away from power source line as possible (at least 5cm). Do not put them in the same conduit.
	② Make sure that transmission line in one system is not bundled with transmission line in another system	Do not bundle transmission lines, since they may cause malfunctions.
	③ Make sure specified transmission wire is used	Use specified transmission wire • For systems using shield wire Type of transmission wire - shield wire CVVS, CPEVS Wire Diameter-over 1.25mm ²

	Check Points	Remedies
Checking the grounding (for systems with shield only)	④Indoor Unit Control Transmission shield line is grounded at the outdoor unit	Use one-point grounding at outdoor unit. When not grounded, transmission signals may be changed by trapped noise and interfere with the communication.
	⑤Check the shield for transmission line (for centralized control)	For the shield earth of the transmission line for centralized control, the effects of noise can be minimized if grounded at the centralized control. However, transmission line for centralized control may be affected in various ways depending on the transmission line length, number of connected units, types of connected controller, or installation condition. Check the following installation conditions: a. No grounding When using upper-rank controller ... Provide grounding at upper-rank controller (power-supply device) b. When one-point grounding is provided but an error occurred ... Ground the shield at all outdoor units.

②When transmission wave height is low. When 6607 error code is displayed or while "HO" is displayed the remote controller.

Check Points	Remedies
⑥The distance between outdoor/heat-source unit and farthest indoor unit exceeds 200m	Make sure that the distance between outdoor/heat-source unit and the farthest indoor unit is less than 200m.
⑦Transmission wire other than the one specified is used	Use specified transmission line. ①For systems using shield line Type of transmission line - shield wire CVVS, CPEVS Wire Diameter-over 1.25mm ²
⑧Choke coil of transmission power-supply circuit is damaged	Normal if the resistance of choke coil in the outdoor/heat-source unit is between 0.5 and 2.6Ω. Normal if resistance R3 of the outdoor main board is 1kΩ ±5%. When measuring resistance, disconnect connectors CNS1 and CNS2.
⑨Malfunctioning indoor unit	Replace indoor controller board.

[2] MA Remote Controller Transmission

MA remote controller and indoor units communicate with each other by using electrical current tone burst method.

(1) Effects of noise in transmission line

When noise enters transmission line and normal communication between MA remote controller and indoor unit cannot be made for three minutes, MA communication error (6831) will be displayed.

(2) Transmission/Wave Pattern Check

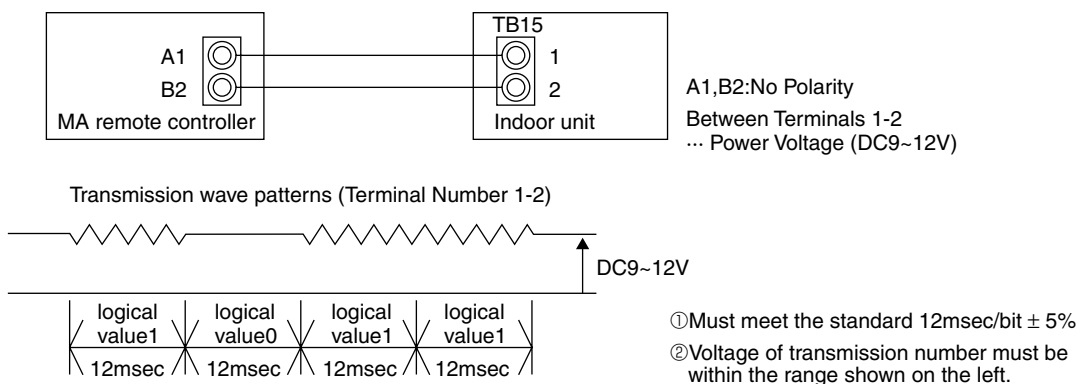

(3) Outdoor Unit Power-Supply Circuit Check

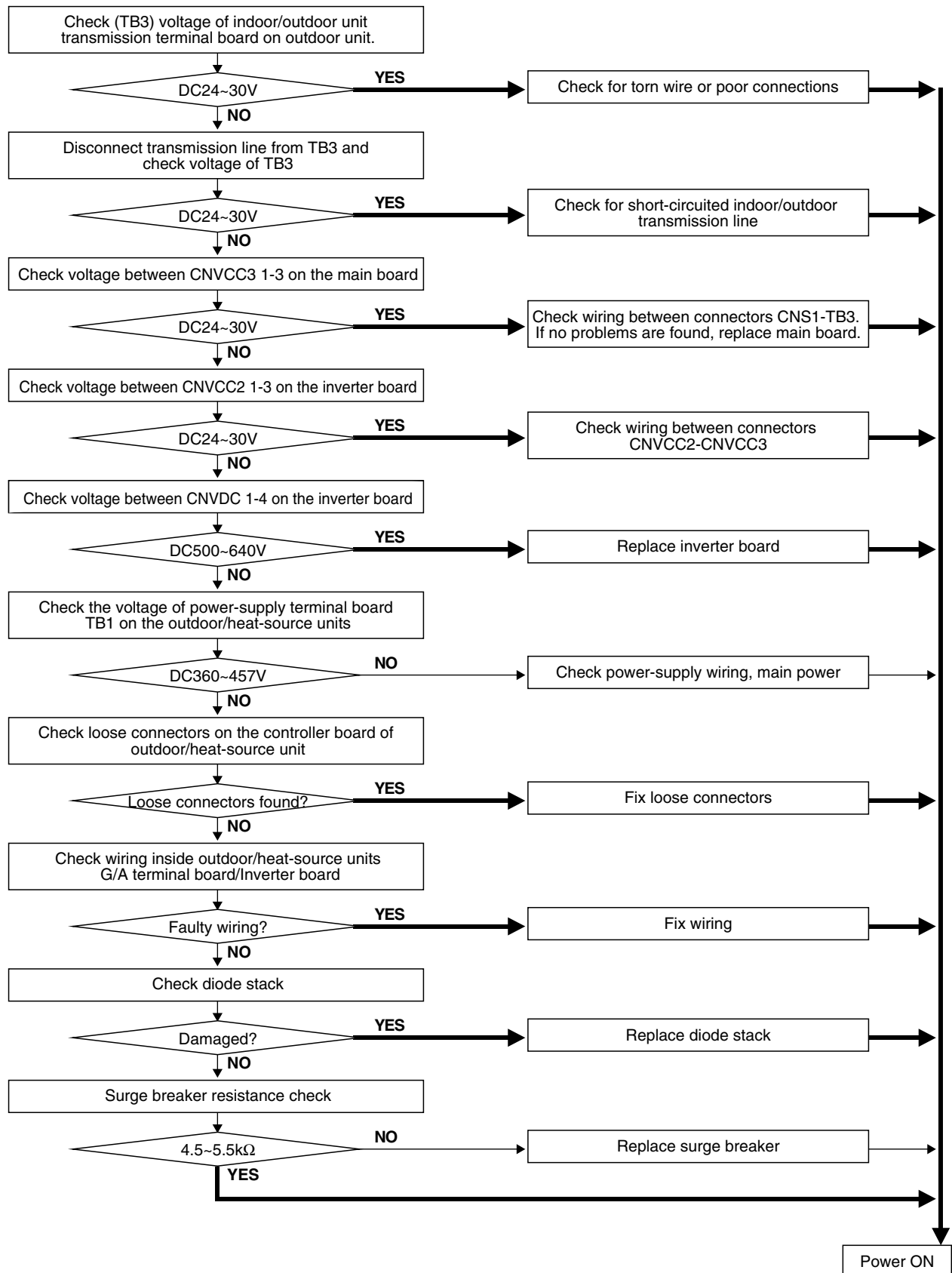

5 Troubleshooting

[1] Principal Parts

Pressure Sensor

(1) Judging Failure

- 1) Check for failure by comparing the sensing pressure according to the high pressure/low pressure pressure sensor and the pressure gauge pressure.
Turn on switches 1, 3, 5, 6 (High) and 2, 4, 5, 6 (Low) of the digital display select switch (SW1) as shown below, and the sensor pressure of the high pressure/low pressure sensors is displayed digitally by the light emitting diode LD1.

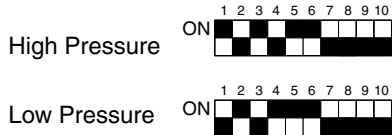

- 1 In the stopped condition, compare the pressure readings from the gauge and from the LD1 display.
 - (a) If the gauge pressure is 0.098MPa, the internal pressure is dropping due to gas leakage.
 - (b) If the pressure according to the LD1 display is 0.098MPa, there is faulty contact at the connector, or it is disconnected. Proceed to 4.
 - (c) If the pressure according to the LD1 display is 3.14MPa or higher, proceed to 3.
 - (d) If other than (a), (b) or (c), compare the pressure readings during operation. Proceed to 2.
- 2 Compare the pressure readings from the gauge and from the LD1 display while in the running condition.
 - (a) If the difference between the two pressures is within 0.098MPa : High pressure, 0.03MPa : Low pressure, both the affected pressure sensor and the main MAIN board are normal.
 - (b) If the difference between the two pressures exceeds 0.098MPa : High pressure, 0.03MPa : Low pressure, the affected pressure sensor is faulty (deteriorating performance).
 - (c) If the pressure reading in the LD1 display does not change, the affected pressure sensor is faulty.
- 3 Disconnect the pressure sensor from the MAIN board and check the pressure according to the LD1 display.
 - (a) If the pressure is 0.098MPa on the LD1 display, the affected pressure sensor is faulty.
 - (b) If the pressure is 3.14MPa (in the case of the low pressure sensor, 0.98MPa or higher, the MAIN board is faulty).
- 4 Disconnect the pressure sensor from the MAIN board and short out the No. 2 and No. 3 pins of the connector (63HS, 63LS), then check the pressure by the LD1 display.
 - (a) If the pressure according to the LD1 display is 3.14MPa (in the case of the low pressure sensor, 0.98MPa or higher, the affected pressure sensor is faulty).
 - (b) If other than (a), the MAIN board is faulty.

2) Pressure sensor configuration.

The pressure sensors are configured in the circuit shown in the figure at right. If DC 5 V is applied between the red and black wires, a voltage corresponding to the voltage between the white and black wires is output and this voltage is picked up by the microcomputer. Output voltages are as shown below.

High Pressure 0.1 V per 0.098MPa (0~2.94MPa)
Low Pressure 0.3 V per 0.098MPa (0~0.98MPa)

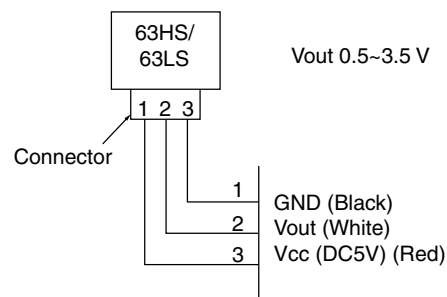

*Connector connection specifications on the pressure sensor body side.

The connector's pin numbers on the pressure sensor body side differ from the pin numbers on the main circuit board side.

	Sensor Body Side	MAIN Board Side
Vcc	Pin 1	Pin 3
Vout	Pin 2	Pin 2
GND	Pin 3	Pin 1

Solenoid Valve (SV1, SV2)

Check if the control board's output signals and the operation of the solenoid valves match.

Setting the self-diagnosis switch (SW1) as shown in the figure below causes the ON signal of each relay to be output to the LED's.

Each LED shows whether the relays for the following parts are on or off. When a LED lights up, it indicates that the relay is on.

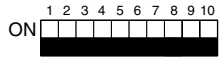
SW1	LED							
	1	2	3	4	5	6	7	8
				SV1	SV2	SV3		

1) In the case of SV1 (Bypass Valve)

- (a) When the compressor starts, SV1 is ON for 4 minutes, so check operation by whether the solenoid valve is emitting an operating noise.
- (b) Changes in the operating condition by solenoid valve operation can be confirmed by the temperature of the bypass circuit and the sound of the refrigerant.

2) In the case of SV2 (Bypass)

- (a) SV2 goes on in accordance with the rise in the high pressure in the cooling mode and heating mode, so check its operation by the LED display and the operating noise emitted by the solenoid valve.
- (b) Changes in the operating condition by solenoid valve operation can be confirmed by the temperature of the bypass circuit and the sound of the refrigerant.

	LED							
	1	2	3	4	5	6	7	8
				SV1	SV2	SV3	SV4	

1) In the case of SV1 (Bypass Valve)

- (a) When the compressor starts, SV1 is ON for 4 minutes, so check operation by whether the solenoid valve is emitting an operating noise.
- (b) Changes in the operating condition by solenoid valve operation can be confirmed by the temperature of the bypass circuit and the sound of the refrigerant.

2) In the case of SV2 (Bypass)

- (a) SV2 goes on in accordance with the rise in the high pressure in the cooling mode and heating mode, so check its operation by the LED display and the operating noise emitted by the solenoid valve.
- (b) Changes in the operating condition by solenoid valve operation can be confirmed by the temperature of the bypass circuit and the sound of the refrigerant.

3) SV3, 4 (Control of heat exchanger capacity)

- (a) Operations can be confirmed by LED display and operating sound of solenoid valve, because one or more of SV3, 4 are turned on depending on conditions during cooling-only operations.

Outdoor LEV

The valve opening angle changes in proportion to the number of pulses.

(Connections between the outdoor unit's MAIN board and SLEV, LEV1 (PUD-P250YMF-C))

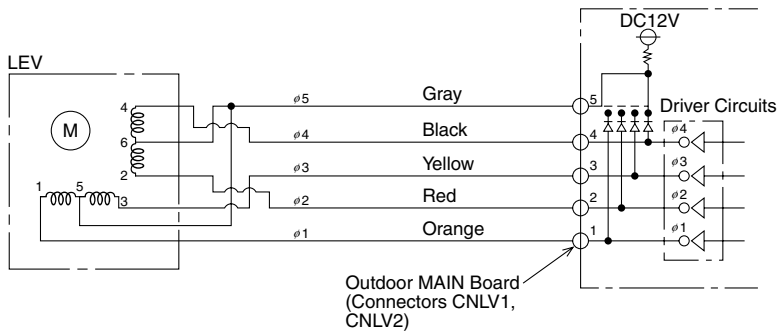

Pulse Signal Output and Valve Operation

Output (phase)	Output states							
	1	2	3	4	5	6	7	8
φ 1	ON	OFF	OFF	OFF	OFF	OFF	ON	ON
φ 2	ON	ON	ON	OFF	OFF	OFF	OFF	OFF
φ 3	OFF	OFF	ON	ON	ON	OFF	OFF	OFF
φ 4	OFF	OFF	OFF	OFF	ON	ON	ON	OFF

Output pulses change in the following orders when the

Valve is Closed 1→2→3→4→5→6→7→8→1

Valve is Open 8→7→6→5→4→3→2→1→8

- *1. When the LEV opening angle does not change, all the output phases are off.
- 2. When the output is out of phase or remains ON continuously, the motor cannot run smoothly, but move jerkily and vibrates.

LEV Valve Closing and Valve Opening Operations

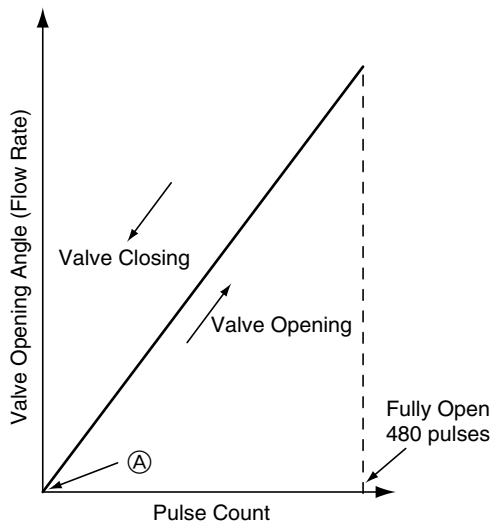

- * When the power is switched ON, a 520 pulse valve opening signal is output to make sure the valve's position, so that it is definitely at point A. (The pulse signal is output for approximately 17 seconds.)
- * When the valve operates smoothly, there is no sound from the LEV and no vibration occurs, but when the valve is locked, it emits a noise.
- * Whether a sound is being emitted or not can be determined by holding a screwdriver, etc. against it, then placing your ear against the handle.
- * If there is liquid refrigerant inside the LEV, the sound may become lower.

Indoor LEV, BC LEV1 and 2

The valve opening angle changes in proportion to the number of pulses.

(Connections between the indoor unit's MAIN board and indoor LEV (PUD-P250YMF-C))

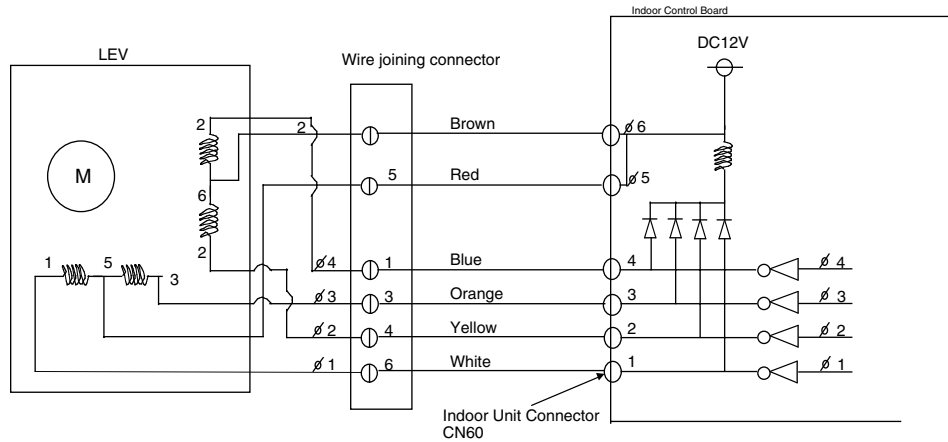

Pulse Signal Output and Valve Operation

Indoor LEV Pulse Signal and Valve Operation

Output Phase	Output State			
	1	2	3	4
$\phi 1$	ON	OFF	OFF	ON
$\phi 2$	ON	ON	OFF	OFF
$\phi 3$	OFF	ON	ON	OFF
$\phi 4$	OFF	OFF	ON	ON

Output pulses change in the following orders when the

Valve is Closed 1→2→3→4→1

Valve is Open 4→3→2→1→4

- * 1. When the LEV opening angle does not change, all the output phases are off.
- 2. When the output is out of phase or remains ON continuously, the motor cannot run smoothly, but move jerkily and vibrates.

LEV Valve Closing and Valve Opening Operations

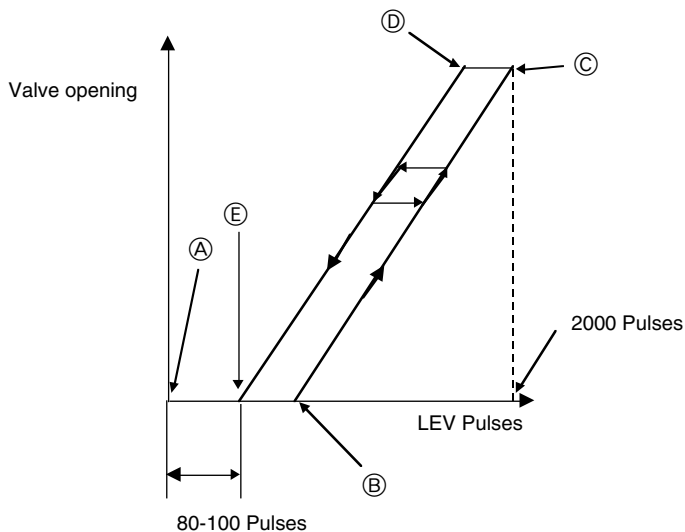

- * When the power is switched ON, a 2200 pulse valve opening signal is output to make sure the valve's position, so that it is definitely at point (A). (Pulse signal is output for approximately 17 seconds.)
- * When the valve operates smoothly, there is no sound from the LEV and no vibration occurs, but when the valve is locked or (E)→(A), it emits a noise
- * Whether a sound is being emitted or not can be determined by holding a screwdriver, etc. against it, then placing your ear against the handle.
- * If there is liquid refrigerant inside the LEV, the sound may become lower.

Judgment methods and likely failure mode

Caution:

The specifications of the outdoor unit (outdoor LEV) and indoor unit (indoor LEV) differ. For this reason, there are cases where the treatment contents differ, so follow the treatment specified for the appropriate LEV as indicated in the right column.

Failure Mode	Judgment Method	Treatment	Affected LEV
Microcomputer driver circuit failure	<p>① Disconnect the control board connector and connect the check LED as shown in the figure below.</p> <div style="display: flex; justify-content: space-around;"> <div style="text-align: center;"> <p>Indoor</p> </div> <div style="text-align: center;"> <p>Outdoor</p> </div> </div> <p>When the base power supply is turned on, the indoor LEV outputs pulse signals for 10 seconds, the outdoor LEV outputs pulse signals for 17 seconds. If the LED does not light up, or lights up and remains on, the driver circuit is abnormal.</p>	In the case of driver circuit failure, replace the control board.	Indoor Outdoor
LEV mechanism is locked.	<p>① If the LEV is locked up, the drive motor turns with no load and a small clicking sound is generated. Generation of this sound when the LEV is fully closed or fully open is abnormal.</p>	Replace the LEV.	Indoor Outdoor
The LEV motor coils have a disconnected wire or is shorted.	<p>Measure the resistance between the coils (red - white, red - orange, brown - yellow, brown - blue) using a tester. They are normal if the resistance is within $150\Omega \pm 10\%$.</p>	Replace the LEV coils.	Indoor
	<p>Measure the resistance between the coils (gray - orange, gray - red, gray - yellow, gray - black) using a tester. They are normal if the resistance is within $46\Omega \pm 3\%$.</p>	Replace the LEV coils.	Outdoor
Fully closed failure (valve leaks)	<p>① If you are checking the indoor unit's LEV, operate the indoor unit's blower and the other indoor units in the cooling mode, then check the piping temperatures (liquid pipe temperatures) of the indoor units by the operation monitor through the heat source unit's control board. When the fan is running, the linear expansion valve is fully closed, so if there is leakage, the temperature sensed by the thermistor (liquid pipe temperature sensor) will become low. If the temperature is considerably low compared to the remote control's intake temperature display, it can be judged that there is a fully closed failure. In the case of minimal leakage, it is not necessary to replace the LEV if there are no other effects.</p> <div style="display: flex; align-items: center;"> <div style="margin-left: 10px;"> <p>Thermistor liquid pipe (temperature sensor)</p> <p>Linear Expansion Valve</p> </div> </div>	If there is a large amount of leakage, replace the LEV.	Indoor
Faulty wire connections in the connector or faulty contact.	<p>① Check for pins not fully inserted on the connector and check the colors of the lead wires visually. ② Disconnect the control board's connector and conduct a continuity check using a tester.</p>	Check the continuity at the places where trouble is found.	Indoor Outdoor

Outdoor LEV (SLEV) Coil Removal Procedure (configuration)

As shown in the figure, the outdoor LEV is made in such a way that the coils and the body can be separated.

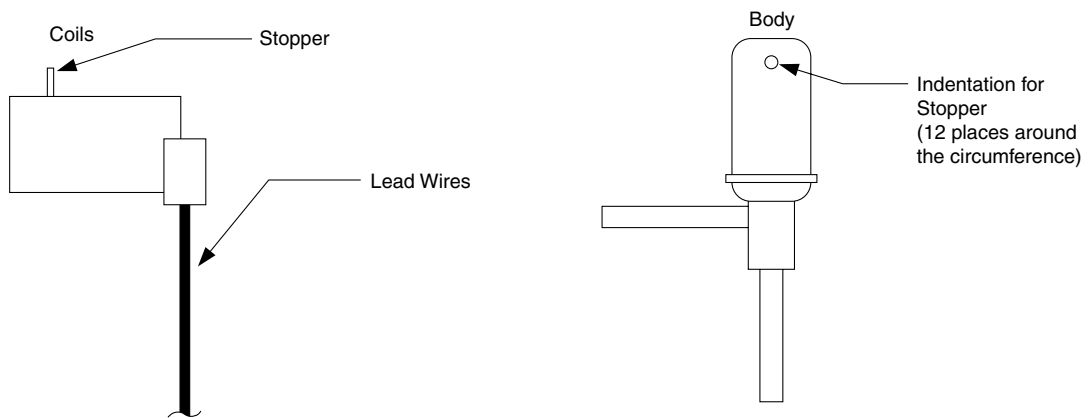

<Removing the Coils>

Fasten the body tightly at the bottom (Part A in the figure) so that the body will not move, then pull out the coils toward the top. If they catch on the stopper and are difficult to take out, turn the coils left and right until the stoppers are free from the stopper indentations, then pull the coils out.

If you take out the coils only without gripping the body, undue force will be applied to the piping and the pipe may be bent over, so be sure to fasten the body in such a way that it will not move.

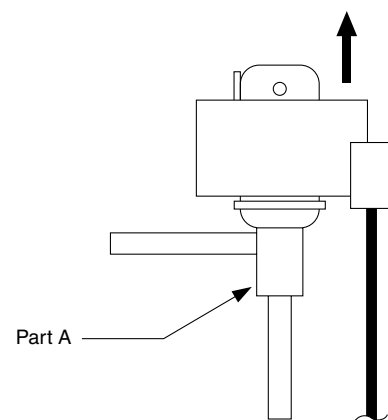

<Installing the Coils>

Fasten the body tightly at the bottom (Part A in the figure) so that the body will not move, then insert the coils from the top, inserting the coils' stopper securely in one of the indentations on the body. (There are four indentations for the stopper on the body around its circumference, and it doesn't matter which indentation is used. However, be careful not to apply undue force to the lead wires or twist them around inside the body.) If the coils are inserted without gripping the body, it may exert undue force on the piping, causing it to become bent, so be sure to hold the body firmly so that it won't move when installing the coils.

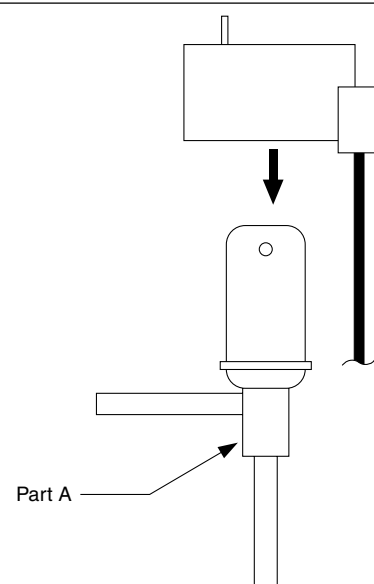

(2) Temperature Sensor

Thermistor for low temperature

Thermistor $R_0 = 15k\Omega \pm 3\%$

(TH5~9 : outdoor unit)

(TH21~24 : indoor unit)

$$R_t = 15 \exp \left\{ 3460 \left(\frac{1}{273+t} - \frac{1}{273+0} \right) \right\}$$

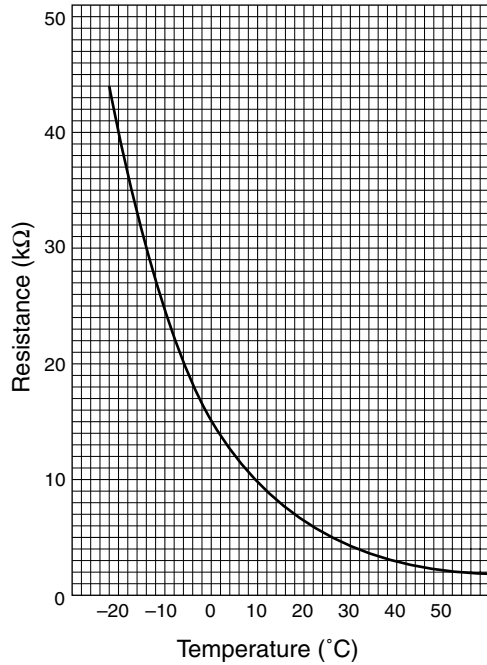

Thermistor $R_{120} = 7.465k\Omega \pm 2\%$

(TH1, 10)

$$R_t = 7.465 \exp \left\{ 4057 \left(\frac{1}{273+t} - \frac{1}{273+120} \right) \right\}$$

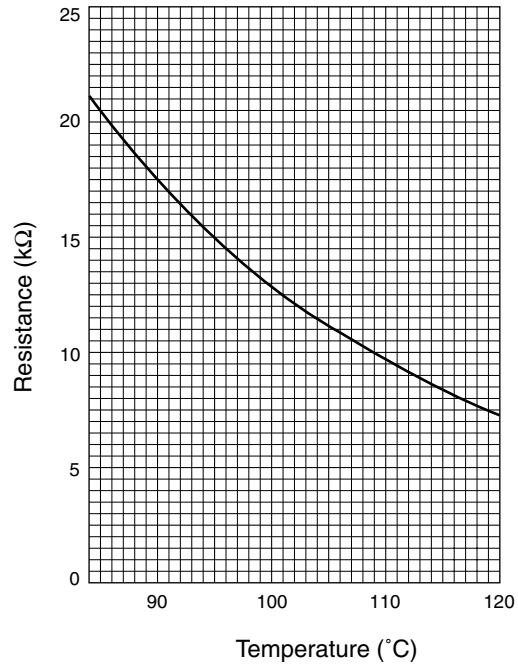

Thermistor $R_0 = 33k\Omega \pm 1\%$ (TH2)

$$R_t = 33 \exp \left\{ 3965 \left(\frac{1}{273+t} - \frac{1}{273+0} \right) \right\}$$

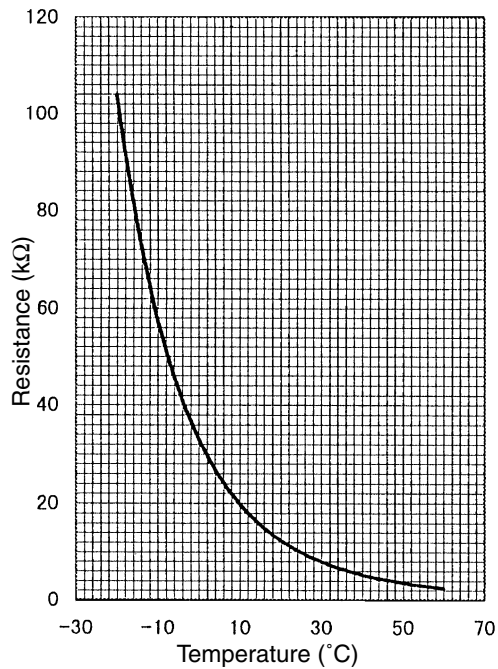

Thermistor $R_{50} = 17k\Omega \pm 2\%$ (THHS)

$$R_t = 17 \exp \left\{ 4170 \left(\frac{1}{273+t} - \frac{1}{273+50} \right) \right\}$$

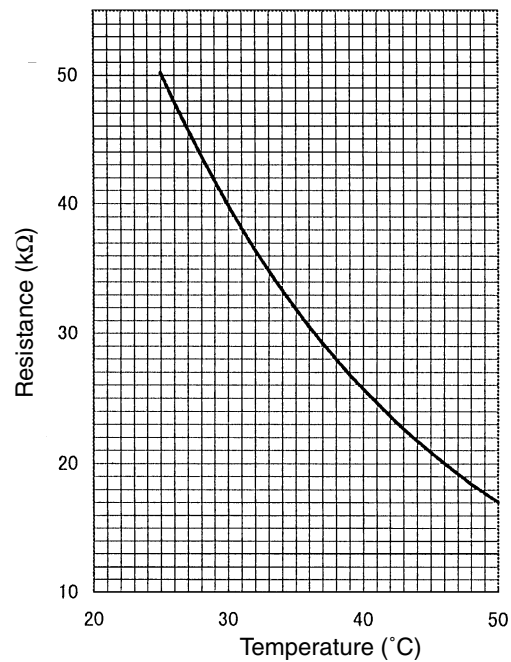

(3) Inverter and Compressor

- a. **Replace only the compressor** if only the compressor is found to be defective.
(Overcurrent will flow through the inverter if the compressor is damaged, however, the power supply is automatically cut when overcurrent is detected, protecting the inverter from damage.)
- b. Replace the defective components if the inverter is found to be defective.
- c. If both the compressor and the inverter are found to be defective, replace the defective components of both devices.

1) Inverter related defect identification and countermeasures

	Error display/failure condition	Measure/inspection item
[1]	Inverter related errors (0403, 4200, 4220, 4230, 4240, 4250, 4260, 5110, 5301)	VIII [1] [2] Check the details of the inverter error in the error log at the outdoor PCB LED monitor display. VII [1] Perform the measures corresponding to the error code and error details determined using the remote control error display self diagnosis and countermeasures.
[2]	Main power breaker trip	a. Check the breaker capacity. b. Electrical system short circuit or grounding other than the inverter c. Refer to 3)-[1] if not a, or b.
[3]	Main power earth leakage breaker trip	a. Earth leakage breaker capacity/sensitivity current check b. Meg defect for electrical system other than the inverter c. Refer to 3)-[1] if not a, or b.
[4]	Only the Compressor does not operate.	· Check the inverter frequency at the LED monitor and proceed to 2)-[3] if the status is operational.
[5]	The compressor always vibrates strongly or emits an abnormal noise.	Go to 2)-[3].
[6]	Noise has penetrated the peripheral device.	a. Check to ensure that power supply wiring, etc. of the peripheral device is not in close contact with the power supply wiring of outdoor unit. b. Check to ensure that the inverter output wiring is not in close contact with the power supply wiring and transmission lines. c. Check to ensure that the transmission line shield wiring is being used properly in the necessary environment, and that the shield wire ground is appropriate. d. Meg defect for electrical system other than the inverter e. Attach a ferrite core to the inverter output wiring. (Please contact the factory for details of the service part settings) f. Change the power to another system. g. If this problem occurs suddenly, there is a possibility that the inverter output is grounded. Proceed to 2)-[3]. * Contact the factory for cases other than those listed above.
[7]	Sudden malfunction (as a result of external noise.)	a. Check to ensure that the unit is grounded. b. Check to ensure that the transmission line shield wiring is being used properly in the necessary environment, and that the shield wire ground is appropriate. c. Check to ensure that the neither the transmission line or external connection wiring run close to another power supply system or run through the same conduct pipe. * Contact the factory for cases other than those listed above.

1. Due to a large capacity electrolytic capacitor used in the inverter, voltage still flows through even after cutting the main power, creating the possibility of electric shock. As a result, wait for a sufficient length of time (5-10 min) after cutting the main power and check the voltage at both terminals of the electrolytic capacitor to performing any checks on the inverter.
2. Damage will result to the components of IPM, etc. if the inverter wiring is not properly secured with screws, or if the connector has not been properly inserted. It is likely that any errors occurring after replacing components are the result of wiring mistakes. Ensure that the wiring, screws, connectors and Faston, etc. are properly inserted.
3. Do not remove or insert inverter connectors with the main power supply on, as this will result in damage to the PCB.
4. The current sensor will be damaged if current flows without connecting to the PCB. Always insert connectors into the corresponding PCB when running the inverter.

2) Treatment of Inverter Output Related Troubles

	Check item	Phenomena	Treatment
[1] Check the INV board error detection circuit.	Perform the following: ①Disconnect INV board CNDR2. After removing, turn on the outdoor unit and check the error status. (The compressor does not operate because CNDR2, which carries the IPM drive signal, has been disconnected.)	① IPM/overcurrent error. (4250 detailed No. 1, 11)	· Replace INV board.
[2] Check for compressor ground fault or coil error.	Disconnect the compressor wiring, and check the compressor Meg, and coil resistance.	①Compressor Meg failure Error if less than 1MΩ. ※ When no refrigerant is accumulated in the compressor. ②Compressor coil resistance failure Coil resistance value of 0.58Ω (20°C)	· Replace compressor Check whether the refrigerant is accumulating in the compressor again.
[3] Check to see if the inverter is damaged. ※Perform this check if an error occurs immediately before or after turning on the compressor.	Perform the following: ①Reconnect the connector removed at item [1]. ②Disconnect the compressor wiring. ③Turn on SW1-1 on the INV board. Operate the outdoor unit after above steps. Check the inverter output voltage. ※ It is recommend to use the tester used to determine the VII [5] [1] (3) 5) IPM troubleshooting when checking the inverter output voltage. ※ Measure when the inverter output frequency is stable.	① IPM/overcurrent error. (4250 detailed No. 1, 11)	· Refer to item [5] for inverter circuit trouble.
		②There is a high possibility of an inverter circuit error if the voltage unbalance across all wiring is greater than 5% or 5V.	
[4] Check to see if the inverter is damaged. ※Perform this check if an error occurs during steady operation.	Turn on the outdoor unit. Check the inverter output voltage. ※ It is recommend to use the tester used to determine the VII [5] [1] (3) 5) IPM troubleshooting when checking the inverter output voltage. ※ Measure when the inverter output frequency is stable.	①There is a high possibility of an inverter circuit error if the voltage unbalance across all wiring is greater than 5% or 5V.	· Refer to item [5] for inverter circuit trouble.
		②No voltage unbalance across all wiring	

	Check item	Phenomena	Treatment
[5] Check the inverter circuit trouble.	①Check to see if the IPM screw terminal is loose.	①Screw terminal is loose.	· Check all IPM screw terminals and tighten.
	②Check the exterior of the IPM.	②IPM is cracked due to swelling.	· IPM replacement Check the operation in [3] or [4] after replacing the IPM. In the case of an output voltage unbalance or error recurrence: → Replace the G/A board In the case of an output voltage unbalance or error recurrence after replacement: → Replace the INV board
	③Check the resistances between each terminal of IPM. Refer to VII [5] [1] (3) 5) for details on IPM troubleshooting.	③Resistance error between each terminal of IPM.	· IPM replacement Check the operation in [3] or [4] after replacing the IPM. In the case of an output voltage unbalance or error recurrence: → Replace the G/A board In the case of an output voltage unbalance or error recurrence after replacement: → Replace the INV board
		④All normal for items ①-③ above	· IPM replacement In the case of an output voltage unbalance or error recurrence after replacement: → Replace the G/A board In the case of an output voltage unbalance or error recurrence after replacement: → Replace the INV board

3) Trouble Measures when Main Power Breaker Tripped

	Check item	Phenomena	Treatment
[1]	Perform Meg check between the terminals in the power terminal block Tba.	①Zero to several ohm, or Meg failure.	Check each part in the main inverter circuit. ※ Refer to "Simple Checking Procedure for Individual Components of Main Inverter Circuit". a. Diode Stack b. IPM c. Rush current protection resistor d. Electromagnetic relay e. DC reactor f. Noise filter
[2]	Turn on the power again and check once more.	①Main power breaker trip ②No remote control display	
[3]	Turn on the outdoor unit and check that it operates normally.	①Operates normally without tripping the main breaker.	a. There is a possibility that the wiring shorted momentarily. Trace the short and repair. b. If a. above is not the case, there is a possibility that there was a compressor failure.
		②Main power breaker trip	· A compressor ground fault can be considered. Go to 2)-[2].

4) Simple Checking Procedure for Individual Components of Main Inverter Circuit

Part name	Judgement method																						
Diode Stack	Refer to "Determining Diode Stack Troubleshooting" (VII 5 [1] (3) 6)																						
IPM (Intelligent Power Module)	Refer to "Determining IPM interference" (VII 5 [1] (3) 5)																						
Rush current protection resistor R1, R5	Measure the resistance between terminals: 4.5~5.5kΩ																						
Electromagnetic contactor (52C)	<p>Measure the resistance value at each terminal.</p> <div style="display: flex; justify-content: space-around; align-items: center;"> <table border="1" style="border-collapse: collapse; text-align: center;"> <tr> <td></td> <td>A2</td> <td>A1</td> <td></td> </tr> <tr> <td>1/L1</td> <td></td> <td>3/L2</td> <td>5/L3</td> </tr> <tr> <td colspan="4" style="height: 40px;"></td> </tr> <tr> <td>2/T1</td> <td>4/T2</td> <td>6/T3</td> <td></td> </tr> </table> <table border="1" style="border-collapse: collapse; text-align: center;"> <thead> <tr> <th>Check Location</th> <th>Judgement value</th> </tr> </thead> <tbody> <tr> <td>A1-A2</td> <td>0.1k~1.3kΩ</td> </tr> <tr> <td>1/L1-2/T1 3/L2-4/T2 5/L3-6/T3</td> <td>∞</td> </tr> </tbody> </table> </div>		A2	A1		1/L1		3/L2	5/L3					2/T1	4/T2	6/T3		Check Location	Judgement value	A1-A2	0.1k~1.3kΩ	1/L1-2/T1 3/L2-4/T2 5/L3-6/T3	∞
	A2	A1																					
1/L1		3/L2	5/L3																				
2/T1	4/T2	6/T3																					
Check Location	Judgement value																						
A1-A2	0.1k~1.3kΩ																						
1/L1-2/T1 3/L2-4/T2 5/L3-6/T3	∞																						
DC reactor DCL	<p>Measure the resistance between terminals: 1Ω or lower (almost 0Ω)</p> <p>Measure the resistance between terminals and the chassis: ∞</p>																						
Cooling fan (MF1)	Measure the resistance between terminals : 0.1k~1.5kΩ																						
Transformer (To1)	<p>Measure the resistance between terminals on the primary side (CNTR1) : 1.0k~2.5kΩ</p> <p>Measure the resistance between terminals on the secondary side (CNTR) : 20~60Ω</p>																						
Current sensor ACCT	<p>Disconnect the CNCT2 target connector and check the resistance between terminals: 35~45Ω</p> <p>1-2PIN (U-phase) 3-4PIN (W-phase)</p> <div style="text-align: center;"> <p>The diagram shows three terminals labeled U, V, and W, which are part of the IPM. Above terminal U, there is a box labeled ACCT-U with an upward-pointing arrow. Above terminal W, there is a box labeled ACCT-W with an upward-pointing arrow. Terminal V is shown in the middle. The label 'IPM' is centered below the terminals.</p> </div> <p>* Check the ACCT connecting phase and direction.</p>																						

5) Intelligent Power Module (IPM)

Measure resistances between each terminal of IPM with tester, and use the results for troubleshooting.

- ① Focus on whether there is a complete open ($\infty\Omega$) state or short-circuit ($\sim 0\Omega$).
The measured resistance value is a guideline and may deviate slightly.
Measure between several similar measurement points.
If the value does not differ by more than double or half from the other points, then judge the state as OK.
- ② Restrictions to applicable tester
Use a tester with an internal power of 1.5V or more.

* Battery type tester

A card tester with button battery has a low applied voltage, so the resistance value of the diode characteristics cannot be measured correctly.

Use a measurement range that measures the low resistance when possible. An accurate measurement with less fluctuation will be possible.

The measured values for troubleshooting are shown in the table below.

• External view

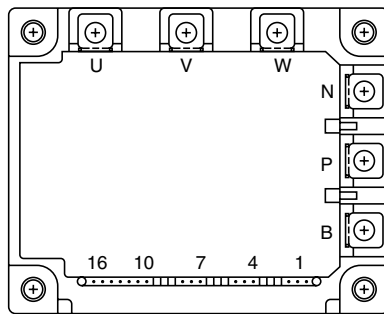

• Internal circuit diagram

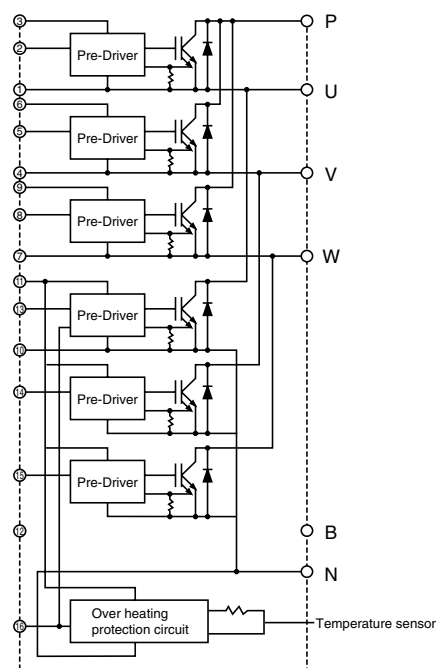

• Judged value

Tester Black / Tester Red	P	N	U	V	W
P			5~200Ω	5~200Ω	5~200Ω
N			∞	∞	∞
U	∞	5~200Ω			
V	∞	5~200Ω			
W	∞	5~200Ω			

6) Diode stack

Perform continuity check with tester. Judged as normal if the following characteristics are observed.
(Restrictions to applicable tester are the same as those of IPM)

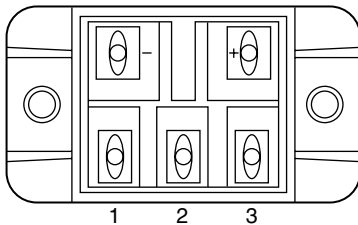

Tester Black / Tester Red	+	-	1	2	3
+			5~200Ω	5~200Ω	5~200Ω
-			∞	∞	∞
1	∞	5~200Ω			
2	∞	5~200Ω			
3	∞	5~200Ω			

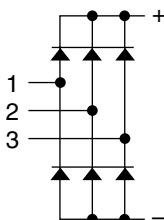

7) Caution at replacement of inverter parts

- ① Fully check wiring for incorrect and loose connection.
The incorrect or loose connection of the power circuit part wiring like IPM and diode module causes to damage the IPM. Therefore, check the wiring fully. As the insufficient tightening of screws is difficult to find, tighten them together additionally after finishing other works. For the wiring of the base for IPM, observe the wiring diagram below carefully as it has many terminals.
- ② Coat the grease for radiation provided uniformly onto the radiation surface of IPM /diode modules.
Coat the grease for radiation on the full surface in a thin layer, and fix the module securely with the screw for fastening. As the radiation grease attached on the wiring terminal causes poor contact, wipe it off if attached.

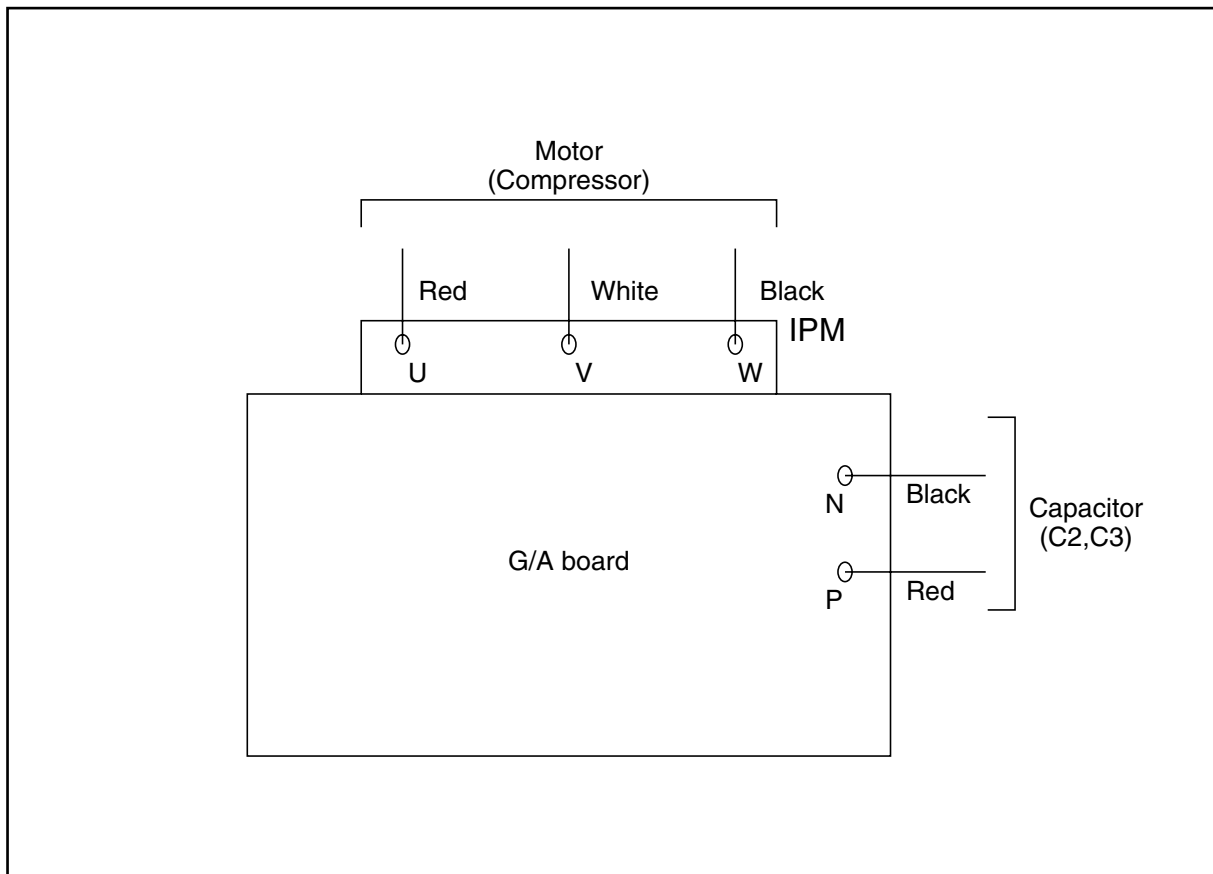

VIII. LED Monitor Display

I How to Read the Service Monitor LED

[1] How to read the LED

By setting of DIPSW1-1 ~ 1-8, the unit operating condition can be observed with the service LED on the control circuit board. (For the relation of each DIPSW to the content, see the table provided.)

As shown in the figure below, the LED consist of 7 segments is put in 4 sets side by side for numerical and graphic display.

OC	: Outdoor unit	SV	: Solenoid valve	THHS	: Inverter radiator panel
IC	: Indoor unit	LEV	: Electronic expansion valve		
		COMP	: Compressor		
SW1	: Outdoor unit control circuit board				
E	: Memory storage for service activities (sampling per minute)				

7 seg LED

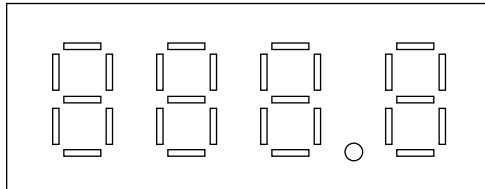

The numerical display includes that of pressure, temperature or the like, while the graphic display includes that of operating condition, solenoid valve ON/OFF state or the like.

- Numerical display

Example : display at 1.84MPa of pressure sensor data (Item No.56)

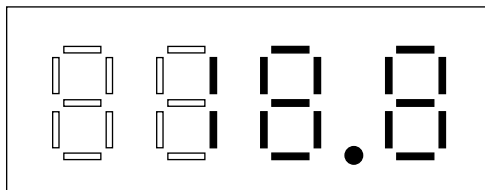

- Graphic display (Two LEDs aligned vertically express a flag.)

Example : At forcible powering in outdoor unit operation display

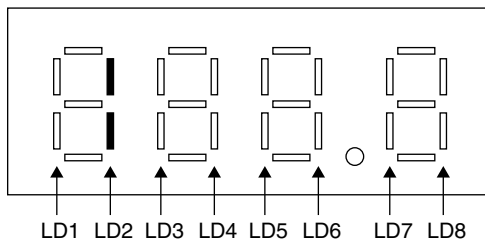

[2] Outdoor Unit Control LED Monitor

①PUD-P250YMF-C

No	SW	Item	Display								Remarks
	12345678		LD1	LD2	LD3	LD4	LD5	LD6	LD7	LD8	
0	00000000	Relay output display 1 (lights to display)	com-pressor operation	Crank-case heater		SV1	SV2	SV3		stays on during normal operation	LD 8 is a relay output. It stays on while the power is on. Terminates monitoring request transmission to IC. If there is no errors '----' is displayed
		Check display 1 OC error	0000 ~ 9999 Address and error code reversed								
1	10000000	Relay output 2									
2	01000000	Check display 2 (including IC)	0000 ~ 9999 Address and error code reversed								If there is no errors '----' is displayed
3	11000000										
4	00100000										
5	10100000	Communication demand capacity	0000 ~ 9999								If no demand control, '----' is displayed [%]
6	01100000	Output signal (Signal during input)	contact point demand	night mode	snow sensor						
7	11100000	Outdoor unit operation display		warm-up mode	3-min restart mode	Com-pressor operation	preliminary error	error			
8	00010000	Indoor unit check	Unit 1								Lights up when IC encounters a problem and stops. It goes off when error reset is carried out.
9	10010000										
10	01010000	Indoor unit operation mode	Unit 1								ON during cooling OFF during stoppage
11	11010000										
12	00110000	Indoor unit thermostat	Unit 1								ON with thermo ON OFF with thermo OFF
13	10110000										
14	01110000										
15	11110000	Outdoor unit operation mode	permissible stop	standby		cooling				demand	
16	00001000	Outdoor unit control mode	cooling, refrigerant collection				cooling, high frequency oil collection	low frequency oil collection			
17	10001000	Outdoor unit preliminary error	high pressure error 1 and 2		discharge temperature error	over current protection	Heat Sink thermostat operating	over current break	INV error	refrigerant overfill	Lights up applicable lights during preliminary errors
18	01001000		vacuum protection error		shell bottom error	configuration detection error					
19	11001000		TH1 error	TH2 error			TH5 error	TH6 error	HPS error	THHS error	
20	00101000		TH7 error	TH8 error		TH10 error	LPS error				

Note. Turn off DIPSW 1-9 while using monitor display.

No	SW	Item	Display								Remarks
	12345678		LD1	LD2	LD3	LD4	LD5	LD6	LD7	LD8	
21	10101000	Outdoor unit preliminary error history	high pressure error 1,2		discharge temperature error	over current protection	heat sink thermo operation	over current break		refrigerant over fill	Lights up if there has been an preliminary error since the unit was turned on. To turn it off, turn off the unit.
22	01101000		Vacuum protection error		shell bottom error	configuration detection error					
23	11101000		TH1 error	TH2 error			TH5 error	TH6 error	HPS error	THHS error	
24	00011000		TH7 error	TH8 error		TH10 error	LPS error				
25	10011000	Error history 1	0000 ~ 9999								Preliminary error code is displayed, Address and error codes reversed, '----' is displayed if there is no problem.
26	01011000	Inverter error detail	Inverter error detail (0001 ~ 9999)								If there is no errors '----' is displayed
27	11011000	Error history 2	0000 ~ 9999								*:Note
28	00111000	Inverter error detail	Inverter error detail (0001 ~ 0009)								
29	10111000	Error history 3	0000 ~ 9999								
30	01111000	Inverter error detail	Inverter error detail (0001 ~ 0009)								
31	11111000	Error history 4	0000 ~ 9999								
32	00000100	Inverter error detail	Inverter error detail (0001 ~ 0009)								
33	10000100	Error history 5	0000 ~ 9999								
34	01000100	Inverter error detail	Inverter error detail (0001 ~ 0009)								
35	11000100	Error history 6	0000 ~ 9999								
36	00100100	Inverter error detail	Inverter error detail (0001 ~ 0009)								
37	10100100	Error history 7	0000 ~ 9999								
38	01100100	Inverter error detail	Inverter error detail (0001 ~ 0009)								
39	11100100	Error history 8	0000 ~ 9999								
40	00010100	Inverter error detail	Inverter error detail (0001 ~ 0009)								
41	10010100	Error history 9	0000 ~ 9999								
42	01010100	Inverter error detail	Inverter error detail (0001 ~ 0009)								
43	11010100	Error history 10	0000 ~ 9999								
44	00110100	Inverter error detail	Inverter error detail (0001 ~ 0009)								
45	10110100	Inverter preliminary error type (Details of No 17 error)	0000 ~ 9999								'----' is displayed if there is no problem. Always overwritten.
46	01110100	TH1 Data	-99.9 ~ 999.9								
47	11110100	TH2 Data	↑								
48	00001100		↑								
49	10001100		↑								
50	01001100	TH5 Data	↑								

*:Note. Inverter error details clarify the nature of errors.

Example : Preliminary code 4300

DIPSW 1-1, 3, 4, 6 ON

- 6 is displayed: lbc sensor/preliminary circuit error
- 7 is displayed: V_{DC} sensor/preliminary circuit error
- 5 is displayed: preliminary serial communication error

No	SW	Item	Display								Remarks
	12345678		LD1	LD2	LD3	LD4	LD5	LD6	LD7	LD8	
51	11001100	TH6 Data	-99.9 ~ 999.9								
52	00101100	THHS Data	↑								
53	10101100	HPS Data	↑								
54	01101100	TH7 Data	↑								
55	11101100	TH8 Data	↑								
56	00011100		↑								
57	10011100	THHS Data	↑								
58	01011100	LPS Data	↑								
59	11011100	α OC	0 ~ 9.999								
60	00111100	α OC*	↑								
61	10111100	α OC*	0 ~ 9.999								
62	01111100	Increase/decrease in HzAK	low Δ Hz -	Δ Hz 0	Δ Hz +	-	-	Δ AK -	Δ AK 0	Δ AK +	
63	11111100	Discrepancy from target Tc (Tcm-Tc)	below -3K	low -3~-2K	low -2~-1K	normal range		high 1~2K	high 2~3K	high over 3K	
64	00000010	Discrepancy from target Te (Tem-Te)	low below -3K	low -3~-2K	low -2~-1K	normal range		high 1~2K	high 2~3K	high over 3K	
65	10000010	Tc	-99.9 ~ 999.9								
66	01000010	Te	↑								
67	11000010	Tcm	↑								
68	00100010	Tem	↑								
69	10100010	Frequency	0000 ~ 9999								Frequency during control
70	01100010	INV output frequency	↑								Actual frequency output by inverter
71	11100010	AK	↑								
72	00010010	SLEV	↑								
73	10010010	LEV1	↑								
74	01010010	Fancon output (T off %)	↑								Fancon output value used for control is displayed
75	11010010	Direct bus current	-99.9 ~ 999.9								IC address (LD1~LD4) are displayed on the left, and capacity codes (LD5~LD8) are displayed on the right. The LED alternate between the two every minute.
76	00110010	OC address	0000 ~ 9999								
77	10110010	IC1 address / capacity codes	0 ~ 99				0 ~ 99				
78	01110010										
79	11110010										
80	00001010										
81	10001010										
82	01001010										
83	11001010										
84	00101010										
85	10101010										

When the unit stops with a problem, No. 93~112 displays data stored in service memory regarding abnormal stoppage, or preliminary errors. (*Note)

No	SW 12345678	Item	Display								Remarks
			LD1	LD2	LD3	LD4	LD5	LD6	LD7	LD8	
86	01101010										
87	11101010										
88	00011010										
89	10011010										
90	01011010										
91	11011010										
92	00111010										
93	10111010	Compressor operation time, upper 4 digits	0000 ~ 9999								
94	01111010	Upper 4 digits	↑								
95	11111010	Outdoor unit operation mode	permissible stop	standby		cooling				demand	
96	00000110	Outdoor unit control mode	cooling, refrigerant collection				cooling, high pressure oil collection		cooling, low pressure oil collection		
97	10000110	Relay output display, on to display	Compressor in operation	crank-case heater		SV1	SV2				
98	01000110	TH1 Data	-99.9 ~ 999.9								
99	11000110	TH2 Data	↑								
100	00100110		↑								
101	10100110		↑								
102	01100110	TH5 Data	↑								
103	11100110	TH6 Data	↑								
104	00010110	HPS Data	↑								
105	10010110	THHS Data	↑								
106	01010110	TH7 Data	↑								
107	11010110	TH8 Data	↑								
108	00110110		↑								
109	10110110	TH10 Data	↑								
110	01110110	LPS Data	↑								
111	11110110	α OC	0 ~ 9.999								
112	00001110	α OC*	↑								
113	10001110	Tc	-99.9 ~ 999.9								
114	01001110	Te	↑								
115	11001110	Composition correction value	↑								

*Note. After encountering IPM/Bus Voltage error (Error code 4250) or surge protection (Error code 4108), data No.93-112(data collected immediately before stoppage) will not be overwritten. After turning DIPSW2-3 (erase error history) OFF and ON and OFF, they will be overwritten. After completing this procedure, if 4250 or 4108 error is encountered, they will again not be overwritten.

No	SW	Item	Display								Remarks
	12345678		LD1	LD2	LD3	LD4	LD5	LD6	LD7	LD8	
116	00101110	INV output frequency	0000 ~ 9999								
117	10101110	AK	↑								
118	01101110	SLEV	↑								
119	11101110	LEV1	↑								
120	00011110	Bus current	-99.9 ~ 999.9								
121	10011110	Outdoor unit operation display		warm-up mode	3-minute restart	Compressor in operation	preliminary error	error			
122	01011110		↑								
123	11011110		↑								
124	00111110		↑								
125	10111110		↑								
126	01111110	Circulating refrigerant composition analysis	0 ~ 1								0→OK, 1→NO
127	11111110										
128	00000001	IC1 suction temperature	-99.9 ~ 999.9								
129	10000001										
130	01000001										
131	11000001										
132	00100001										
133	10100001										
134	01100001										
135	11100001										
136	00010001										
137	10010001										
138	01010001										
139	11010001										
140	00110001										
141	10110001										
142	01110001										
143	11110001										
144	00001001	IC1 liquid pipe temperature	-99.9 ~ 999.9								
145	10001001										
146	01001001										
147	11001001										
148	00101001										
149	10101001										
150	01101001										

No	SW	Item	Display								Remarks
	12345678		LD1	LD2	LD3	LD4	LD5	LD6	LD7	LD8	
151	11101001										
152	00011001										
153	10011001										
154	01011001										
155	11011001										
156	00111001										
157	10111001										
158	01111001										
159	11111001										
160	00000101	IC1 gas pipe temperature					-99.9 ~ 999.9				
161	10000101										
162	01000101										
163	11000101										
164	00100101										
165	10100101										
166	01100101										
167	11100101										
168	00010101										
169	10010101										
170	01010101										
171	11010101										
172	00110101										
173	10110101										
174	01110101										
175	11110101										
176	00001101	IC1 SH					-99.9 ~ 999.9				
177	10001101										
178	01001101										
179	11001101										
180	00101101										
181	10101101										
182	01101101										
183	11101101										
184	00011101										
185	10011101										
186	01011101										
187	11011101										
188	00111101										

No	SW	Item	Display								Remarks
	12345678		LD1	LD2	LD3	LD4	LD5	LD6	LD7	LD8	
189	10111101										
190	01111101										
191	11111101										
192	00000011										
193	10000011										
194	01000011										
195	11000011										
196	00100011										
197	10100011										
198	01100011										
199	11100011										
200	00010011										
201	10010011										
202	01010011										
203	11010011										
204	00110011										
205	10110011										
206	01110011										
207	11110011										
208	00001011	IC1 LEV degree of opening					0000 ~ 9999				
209	10001011										
210	01001011										
211	11001011										
212	00101011										
213	10101011										
214	01101011										
215	11101011										
216	00011011										
217	10011011										
218	01011011										
219	11011011										
220	00111011										
221	10111011										
222	01111011										
223	11111011										
224	00000111	IC1 operation mode									
225	10000111						0000 : stop				
226	01000111						0002 : cooling				

No	SW	Item	Display								Remarks
	12345678		LD1	LD2	LD3	LD4	LD5	LD6	LD7	LD8	
227	11000111										
228	00100111										
229	10100111										
230	01100111										
231	11100111										
232	00010111										
233	10010111										0000 : stop 0002 : cooling
234	01010111										
235	11010111										
236	00110111										
237	10110111										
238	01110111										
239	11110111										
240	00001111	IC1 filter									0000 ~ 9999
241	10001111										
242	01001111										
243	11001111										
244	00101111										
245	10101111										
246	01101111										
247	11101111										
248	00011111										
249	10011111										
250	01011111										
251	11011111										
252	00111111										
253	10111111										
254	01111111										
255	11111111										

IX. Test Run

1 Before a Test Run

1	Check for refrigerant leak and loose power supply/transmission connections.
2	Make sure that the resistance between the power supply terminal block and the ground exceeds 1.0MΩ by measuring it with a DC500V megger. Notes: 1. Do not run a test if insulation resistance is under 1.0MΩ. 2. Do not use megger on transmission terminal block, as it will damage the main board. 3. Immediately after installation or when left without being powered for an extended period of time, insulation resistance between the power supply terminal block and the ground may drop near 1MΩ due to an accumulation of refrigerant in the compressor. 4. If insulation resistance is at least 1MΩ, by supplying power to the crankcase heater for no less than 12 hours, refrigerant in the compressor will evaporate, and the resistance will go up.
3	Make sure that the ball valves on both gas and liquid sides are fully open. Notes: Be sure to keep the cap on.
4	Make sure that gas pipes and liquid pipes in a 2-refrigerant circuit are not cross-connected.
5	Make sure that the three power supply wires are connected correctly, and also check the voltage between each phase. Notes: Error codes 4102 or 4103 will be displayed if improper connections are made (absent or reverse phase).
6	Turn on the main switch to power the crankcase heater at least 12 hours before test run. Notes: Shorter powering time will cause compressor problems.

2 Test-Run Method

Run a test by using DIPSW3-1, 2 on the controller board in the outdoor unit controller box.

Procedures	
	Turn on the power at least 12 hours before test run. → It will take approximately one minute until the unit is operable. Leave the unit on for 12 hours (to power the outdoor unit compressor crankcase heater).
	Run an individual test on each of the refrigerant circuit to make sure that pipes or wires are not cross-connected.
①	First, run a test on No.1-side refrigerant circuit.
②	Set the Normal/Maintenance Switch of the indoor unit to Maintenance.
③	While the unit is stopped, set Slide SWA on the address board of No.2-side refrigerant circuit to 3. (See Note 1).
④	Run a test , using the remote controller for the indoor unit. → Indoor fan will start, and outdoor unit of only No.1 refrigerant circuit will start operating. During this time, the outdoor unit on No.2-side refrigerant circuit will remain at a halt. → Confirm that indoor fan and outdoor unit in the No.1-side refrigerant circuit operate normally. → Confirm that pipes or wires are connected correctly.
⑤	Stop the operation with the remote controller for the indoor unit. → End of No.1 refrigerant circuit test run.
⑥	Run a test on No.2-side refrigerant circuit.
⑦	While the unit is stopped, set the slide switch SWA on the controller board of No.1-side refrigerant circuit to 3, and slide switch SWA on the controller board of No.2-side refrigerant circuit to 1.
⑧	Run a test by using the remote controller in the indoor unit. → Indoor fan will start, and only the outdoor unit in No.2-side refrigerant circuit will start. During this time, the outdoor unit in No.1-side refrigerant circuit is stopped. → Confirm that indoor fan and outdoor unit of No.2-side refrigerant circuit are operating normally. → Confirm that pipes and wires are connected correctly.
⑨	Stop the test, using the remote controller for the indoor unit. → End of No.2 refrigerant circuit test run.
⑩	While the unit is stopped, set the slide SWA on the address board of No.1-side refrigerant circuit to 1.
⑪	Finally, run simultaneous tests in both No.1- and No.2-side refrigerant circuit.
⑫	Indoor fan will start, and outdoor units in both No.1- and No.2-side refrigerant circuit will start. → Confirm that indoor fan and both outdoor units operate normally.
⑬	Stop the test, using the remote controller in the indoor unit → End of test
⑭	Switch the Normal/Maintenance switch inside indoor unit back to Normal. → Be sure to set the Normal/Maintenance switch back to Normal and SWA on the address boards of both No.1 and No.2 units back to 1.

Note 1. If the test is started without setting the SWA as shown below, both refrigerant circuit will start the operations.

To test each refrigerant circuit individually, set SWA as follows:

Slide Switch SWA on the address board of indoor unit

SWA Setting	Unit Operation	Remarks
1	Runs test when so directed	Factory Setting
3	Remain at a halt	

Note 2. When error lamps on indoor unit illuminate during test run, check codes will be displayed on the remote controller. Refer to VII. (Troubleshooting) for the meaning of each check code.

Note 3. Turn on DIPSW3-7 of the outdoor unit (while the unit is not in operation) when unable to continue the operation during low-load operation. **Be sure to turn them off after test run.**

Note 4. For 1-refrigerant systems, skip items 3, and 6 through 13 above.

3 Not to Be Alarmed When the Following Symptoms Appear

Symptoms	Display on the Remote Controller	Cause
Outdoor unit will not start	Normal display	The unit will take up to 35 minutes to warm up the compressor when outdoor unit is cooled while DIPSW2-7 are on (Factory Setting - OFF) and liquefied refrigerant has accumulated in the compressor. The unit will start after the compressor has sufficiently warmed up. (When outdoor temperature is under 5°C the unit will not start for up to 30 minutes. During this time the unit will be in a fan mode.

The phenomena below are also a part of normal operations

Symptoms	Caution	Remedies
Outdoor unit noise	The noise level listed in product specification is the level measured in an anechoic room. Noise level may vary considerably depending on the environment in which the unit is installed.	<ul style="list-style-type: none"> Do not install the unit in or around residential areas where noise levels are to be kept down. Consult us if concerned about the effects of noise.
Effects of noise	Air conditioners use microcomputers, and they emit a minute amount of electric noise from the power source, transmission lines, and the body of the units. Air conditioners may have an adverse effect on equipments that uses electrically fine signals (wireless microphones, medical equipments etc) and may cause them to malfunction if used in close proximities, or vice versa, Try the remedies listed on the right if this kind of problems are anticipated.	<ul style="list-style-type: none"> Place equipment that is likely to be affected by noise (wireless microphone receiver or antenna etc.) as far away as possible from the unit's transmission lines, power source line, and the body of the unit. Isolate the power supply line of the equipment that emits a large amount of noise from air-conditioning power source, and keep them as far away as possible from transmission lines, power-supply line, and the body of the unit.

4 Standard Operation (reference data)

[1] Cooling Operation

Items		Unit Types	-	Indoor : PFD-P250VM-A Outdoor : PUD-P250YMF-C × 1	Indoor : PFD-P500VM-A Outdoor : PUD-P250YMF-C × 2
Conditions	Ambient Air Temperature	Indoor	°CDB	27 / 19	
		Outdoor	°CWB	35 / 24	
	Indoor Unit	No. of Units Connected	quantity	1	
		No. of Units in Operation		1	
		Model Type	-	250	500
	Piping	Total Piping Length	m	7.5	
	Refrigerant Volume		kg	11.4 × 1 refrigerant circuit	11.4 × 2 refrigerant circuit
	Electric Current		A	36.1 / 34.3 / 33.0	
Voltage		V	380 / 400 / 415		
LEV Opening	Indoor Unit		Pulse	360	
	SC (LEV1)			132	
	Oil Return (SLEV)			200	
Pressure	High Pressure (after O/S) Low Pressure (before MA)		MPa	2.15 / 0.65	
Temperature of Various Parts of the Unit	Outdoor Unit	Discharge (TH1)	°C	97	
		Heat Exchanger Outlet (TH5)		42	
		Accumulator Inlet		15.8	
		Accumulator Outlet		18.8	
		Compressor Inlet		21.8	
		Low-Pressure 2-phase Temperature (TH2)		10.6	
		Compressor shell bottom		75	
		SC heat exchanger outlet (TH7)		27	
		Bypass Outlet (TH8)		16.6	
	Indoor Unit	LEV Inlet		26	
		Heat Exchanger Outlet		20.8	
	Refrigerant Composition Detection Value (αOC)			0.23	

[2] Operation under Other Conditions

(1) Changes in Circulating

Generally, circulating composition αOC increases in response to an increase in excess refrigerant amount in the accumulator, since αOC increases when indoor operation load of the indoor unit is small or when outdoor temperature is low.

αOC is considered normal when it is within the range listed in Note 2. in chapter XI (Circulating Refrigerant Composition Analysis) αOC being within this range, there will not be a problem with lack of operation capacity.

(2) Change in Indoor Unit Operation Load

Compressor frequency changes while high pressure and low pressure remain nearly constant. Compressor frequency changes in proportion to indoor operation load.

(3) Changes in Outdoor Air Temperature

Compressor frequency changes while high pressure and low pressure remain nearly constant. During a cooling operation, the lower the outdoor temperature, the smaller compressor frequency.

X. When Refrigerant Leaks

I Repairing Leaks: Preparation, making repairs, and recharging the system with refrigerant.

[1] Location of leaks: Extension piping or indoor unit

- ① Connect a pressure gauge to the low-pressure servicing check joint CJ2.
- ② Test run all indoor units in cooling mode.
 1. With SW3-1 on the MAIN board of the outdoor unit set to ON and SW3-2 OFF → ON to test run all indoor units.
 2. Change the remote controller settings so that all indoor units run in cooling mode.
 3. Check that all indoor units are running in cooling mode.
- ③ Perform a pump down operation.
 1. Close the liquid ball valve (BV2) on the outdoor unit to begin the pump down.
- ④ When the pressure gauge on the low-pressure servicing check joint CJ2 reads 0.20MPa, stop all indoor units and the compressor.
 1. With SW3-1 on the MAIN board of the outdoor unit set to ON and SW3-2 ON → OFF to stop all indoor units and the compressor.
 2. Check that all indoor units have been stopped.
- ⑤ Close the gas ball valve (BV1) on the outdoor unit.
- ⑥ Remove any refrigerant remaining in the extension piping or the indoor units.
Reclaim the refrigerant; do not discharge it into the air.
- ⑦ Repair the leak point.
- ⑧ After the leak point is repaired, extract all air from the extension piping and the indoor units to create a vacuum.
- ⑨ Open both ball valves (BV1 and BV2) on the outdoor unit, then adjust the refrigerant amount and verify that the refrigerant is circulating properly.

[2] Location of leaks: Outdoor unit

- ① Test run all indoor units in cooling mode.
 1. With SW3-1 on the MAIN board of the outdoor unit set to ON and SW3-2 OFF → ON to test run all indoor units.
 2. Change the remote controller settings so that all indoor units run in cooling mode.
 3. Check that all indoor units are running in cooling mode.
- ② Check the Tc and TH7 data
(The self-diagnosis switch (SW1) on the MAIN board of the outdoor unit can be used to display this data on the LED.)
 1. If Tc – TH7 is 10 degrees or more Continue to step ③.
 2. If Tc – TH7 is less than 10 degrees After stopping the compressor, remove any refrigerant, repair the leak point, then extract the air to create a vacuum and refill with new refrigerant (same procedure as 4. Location of leaks: Outdoor unit (when heating)).

[Tc self-diagnosis switch]

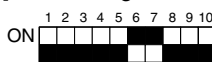

[TH7 self-diagnosis switch]



- ③ Stop all indoor units and the compressor.
 1. With SW3-1 on the MAIN board of the outdoor unit set to ON and SW3-2 ON → OFF to stop all indoor units and the compressor.
 2. Check that all indoor units have been stopped.
- ④ Close both ball valves (BV1 and BV2).
- ⑤ Remove a small amount of refrigerant from the liquid ball valve (BV2) check joint. If this operation is not performed, remaining refrigerant may cause the unit to malfunction.
- ⑥ Remove any refrigerant remaining in the outdoor unit.
Reclaim the refrigerant; do not discharge it into the air.
- ⑦ Repair the leak point.
- ⑧ After the leak point is repaired, change the drier and extract all of the air from the outdoor unit to create a vacuum.
- ⑨ Open both ball valves (BV1 and BV2) on the outdoor unit, then adjust the refrigerant amount and verify that the refrigerant is circulating properly.

XI . Circulating Composition Analysis

I Check the Composition of the Refrigerant

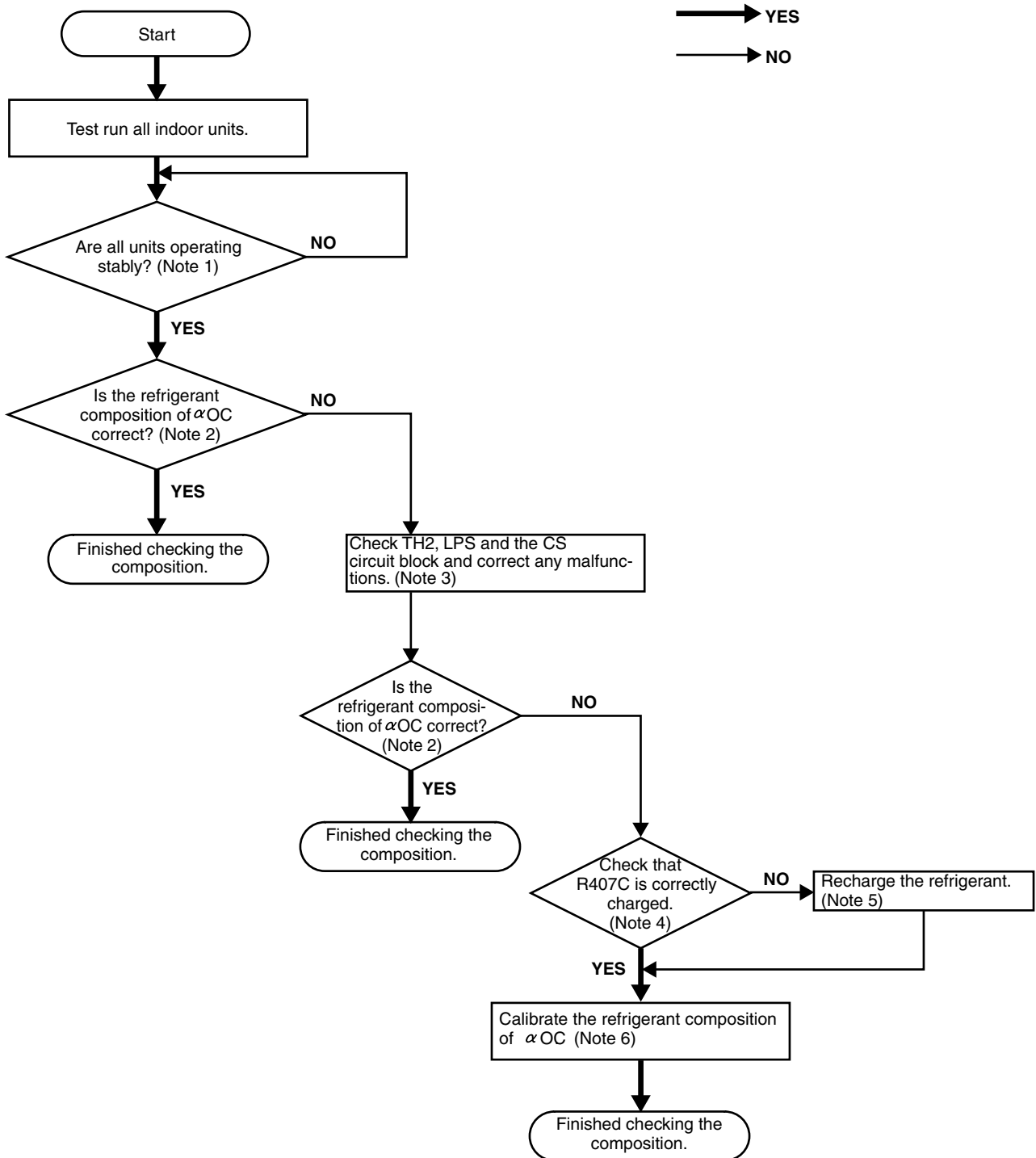

Note 1 Wait until the units stabilize as described in the refrigerant amount adjustment procedure in “Chapter 6”.

Note 2 After the units are operating stably, check that the refrigerant composition of α OC is within the following ranges, indicating that the composition check is finished.

If the accumulator liquid level AL = 0 when cooling: α OC = 0.20 ~ 0.26

If the accumulator liquid level AL = 1 when cooling: α OC = 0.23 ~ 0.34

When heating: α OC = 0.25 ~ 0.34

(The self-diagnosis switch (SW1) on the main board of the outdoor unit can be used to display this data on the LED.)

[α OC self-diagnosis switch]

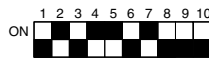

Note 3 TH2 Check and make any corrections using the same method as that for a faulty temperature sensor, (refer to TROUBLESHOOTING).

LPS: Check and make any corrections using the same method as that for a faulty low pressure sensor, (refer to TROUBLESHOOTING).

CS circuit block: Set the self-diagnosis switch on the outdoor MAIN board as shown below.



- Check and make any corrections so that “0” is displayed.
- If any number other than 0 is displayed and TH2, or LPS are malfunctioning, correct them, then set SW3-8 on the MAIN board of the outdoor unit from OFF to ON.
- If any number other than 0 is displayed and TH2, or LPS are not malfunctioning, replace the CS circuit if refrigerant is not flowing through it (while operating) and set SW3-8 on the MAIN board of the outdoor unit from OFF to ON.

Note 4 If it can be verified that R407C was correctly charged in the liquid phase, continue to Yes. If there is a possibility that it was not charged correctly, such as with a gas charger, continue to No.

Note 5 After reclaiming the system’s refrigerant, extract the air to create a vacuum, then refill with new refrigerant. Be sure to charge in the liquid phase. In addition, be sure to change the dryer.

Note 6 After the units are operating stably, check that the refrigerant composition of α OC is within the following ranges, indicating that the circulation check is finished.

If the accumulator liquid level AL = 0 when cooling: α OC = 0.21 ~ 0.25

If the accumulator liquid level AL = 1 when cooling: α OC = 0.24 ~ 0.28

When heating: α OC = 0.27 ~ 0.31

If the refrigerant composition of α OC is not within the ranges specified above, a large error has been detected. Refer to section 1-3 in Chapter 6, then after setting SW4-1 on the MAIN board of the outdoor unit to ON, calibrate the refrigerant circulation constant α OC with SW4-2 until it is within the ranges specified above.

After calibrating, keep the SW4-1 ON and finish the circulation check.

<Example calibration of the refrigerant circulation constant α OC>

Conditions: If the accumulator liquid level AL = 0 and α OC = 0.29 when cooling, α OC must be adjusted so that it is between 0.21 and 0.25.

By switching SW4-2 between ON and OFF, adjustments can be made in the following order:

0 → 3% → 6% → 9% → 12% → -6% → -3% → 0

For this example, by making an adjustment of -0.06 (-6%), α OC can be adjusted to 0.23.

1. If SW4-2 is already set to OFF, change the switch 5 times.
OFF (0.29) → ON (0.32) → OFF (0.35) → ON (0.38) → OFF (0.41) → ON (0.23)
2. If SW4-2 is already set to ON, change the switch 5 times.
ON (0.29) → OFF (0.32) → ON (0.35) → OFF (0.38) → ON (0.41) → OFF (0.23)