

July 2006

 No. OC356
 REVISED EDITION-A

TECHNICAL & SERVICE MANUAL

Series PKFY Wall Mounted R410A / R407C / R22

<Indoor unit>
 [Model names]

PKFY-P63VFM-E

PKFY-P100VFM-E

[Service Ref.]

PKFY-P63VFM-E
PKFY-P100VFM-E

Revision:

- RoHS PARTS LIST is added.
- Some descriptions have been modified.

- Please void OC356.

Note:

- This manual describes only service data of the indoor units.
- RoHS compliant products have <G> mark on the spec name plate.
- For servicing of RoHS compliant products, refer to the RoHS Parts List.

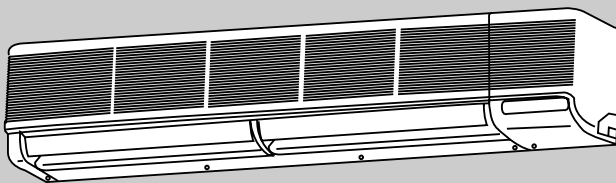

Indoor unit

CONTENTS

1. SAFETY PRECAUTION	2
2. PART NAMES AND FUNCTIONS	6
3. SPECIFICATIONS	8
4. OUTLINES AND DIMENSIONS	11
5. WIRING DIAGRAM	13
6. REFRIGERANT SYSTEM DIAGRAM	14
7. TROUBLE SHOOTING	15
8. DISASSEMBLY PROCEDURE	22
9. PARTS LIST	25
10. RoHS PARTS LIST	28

1

SAFETY PRECAUTION

CAUTIONS RELATED TO NEW REFRIGERANT

Cautions for units utilizing refrigerant R407C

Do not use the existing refrigerant piping.

The old refrigerant and lubricant in the existing piping contains a large amount of chlorine which may cause the lubricant deterioration of the new unit.

Use liquid refrigerant to seal the system.

If gas refrigerant is used to seal the system, the composition of the refrigerant in the cylinder will change and performance may drop.

Use "low residual oil piping"

If there is a large amount of residual oil (hydraulic oil, etc.) inside the piping and joints, deterioration of the lubricant will result.

Do not use a refrigerant other than R407C.

If another refrigerant (R22, etc.) is used, the chlorine in the refrigerant may cause the lubricant deterioration.

Store the piping to be used during installation indoors with keep both ends sealed until just before brazing. (Store elbows and other joints in a plastic bag.)

If dust, dirt, or water enters the refrigerant cycle, deterioration of the oil and compressor trouble may result.

Use a vacuum pump with a reverse flow check valve.

The vacuum pump oil may flow back into the refrigerant cycle and cause the lubricant deterioration.

Use ESTR, ETHER or HAB as the lubricant to coat flares and flange connection parts.

If large amount of mineral oil enter, that can cause deterioration of refrigerant oil etc.

Ventilate the room if refrigerant leaks during operation. If refrigerant comes into contact with a flame, poisonous gases will be released.

[1] Cautions for service

- After recovering the all refrigerant in the unit, proceed to working.
- Do not release refrigerant in the air.
- After completing the repair service, recharge the cycle with the specified amount of liquid refrigerant.

[2] Refrigerant recharging

(1) Refrigerant recharging process

- ① Direct charging from the cylinder.
 - R407C cylinder are available on the market has a syphon pipe.
 - Leave the syphon pipe cylinder standing and recharge it.
(By liquid refrigerant)

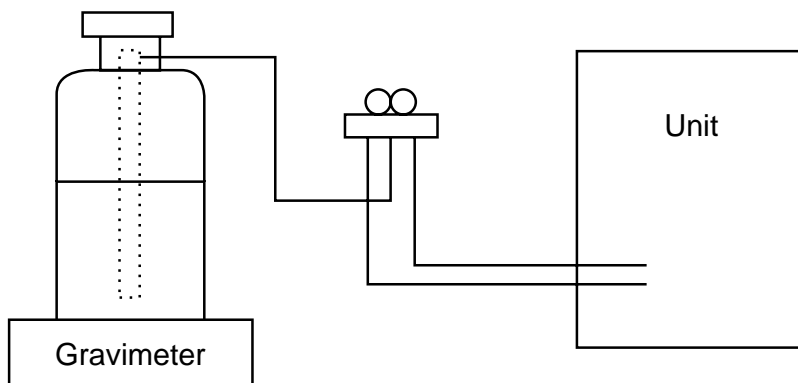

(2) Recharge in refrigerant leakage case

- After recovering the all refrigerant in the unit, proceed to working.
- Do not release the refrigerant in the air.
- After completing the repair service, recharge the cycle with the specified amount of liquid refrigerant.



[3] Service tools

Use the below service tools as exclusive tools for R407C refrigerant.

No.	Tool name	Specifications
①	Gauge manifold	·Only for R407C.
		·Use the existing fitting SPECIFICATIONS. (UNF7/16)
		·Use high-tension side pressure of 3.43MPa-G or over.
②	Charge hose	·Only for R407C.
		·Use pressure performance of 5.10MPa-G or over.
③	Electronic scale	_____
④	Gas leak detector	·Use the detector for R134a or R407C.
⑤	Adapter for reverse flow check.	·Attach on vacuum pump.
⑥	Refrigerant charge base.	_____
⑦	Refrigerant cylinder.	·For R407C ·Top of cylinder (Brown)
		·Cylinder with syphon
⑧	Refrigerant recovery equipment.	_____

Cautions for units utilizing refrigerant R410A

Do not use the existing refrigerant piping.

The old refrigerant and lubricant in the existing piping contains a large amount of chlorine which may cause the lubricant deterioration of the new unit.

Use "low residual oil piping"

If there is a large amount of residual oil (hydraulic oil, etc.) inside the piping and joints, deterioration of the lubricant will result.

Store the piping to be used during installation indoors and keep both ends of the piping sealed until just before brazing. (Leave elbow joints, etc. in their packaging.)

If dirt, dust or moisture enter into refrigerant cycle, that can cause deterioration of refrigerant oil or malfunction of compressor.

Use ester oil, ether oil or alkylbenzene oil (small amount) as the refrigerant oil applied to flares and flange connections.

If large amount of mineral oil enter, that can cause deterioration of refrigerant oil etc.

Charge refrigerant from liquid phase of gas cylinder.

If the refrigerant is charged from gas phase, composition change may occur in refrigerant and the efficiency will be lowered.

Do not use refrigerant other than R410A.

If other refrigerant (R22 etc.) is used, chlorine in refrigerant can cause deterioration of refrigerant oil etc.

Use a vacuum pump with a reverse flow check valve.

Vacuum pump oil may flow back into refrigerant cycle and that can cause deterioration of refrigerant oil etc.

Use the following tools specifically designed for use with R410A refrigerant.

The following tools are necessary to use R410A refrigerant.

Tools for R410A	
Gauge manifold	Flare tool
Charge hose	Size adjustment gauge
Gas leak detector	Vacuum pump adaptor
Torque wrench	Electronic refrigerant charging scale

Keep the tools with care.

If dirt, dust or moisture enter into refrigerant cycle, that can cause deterioration of refrigerant oil or malfunction of compressor.

Do not use a charging cylinder.

If a charging cylinder is used, the composition of refrigerant will change and the efficiency will be lowered.

Ventilate the room if refrigerant leaks during operation. If refrigerant comes into contact with a flame, poisonous gases will be released.

● **Indoor Unit**

PKFY-P63VFM-E

PKFY-P100VFM-E

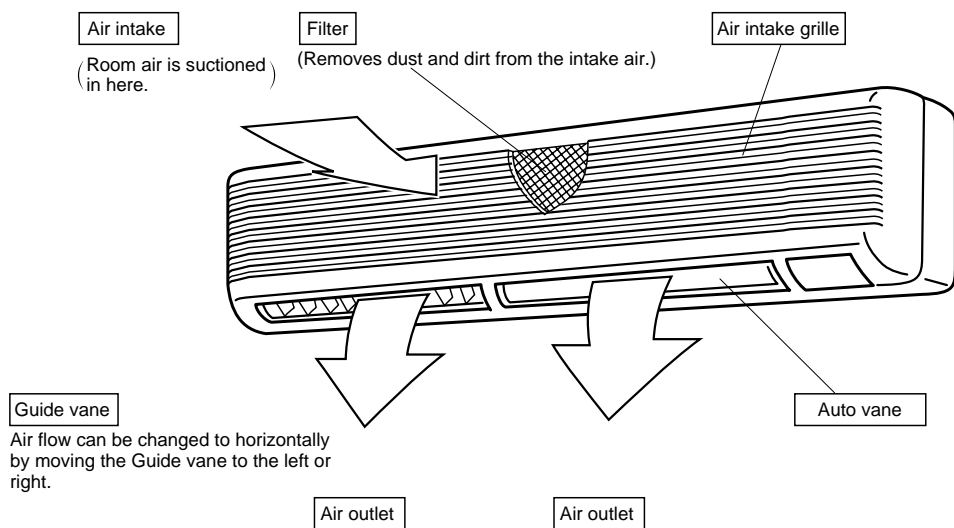

● **Wired remote controller**

On the controls are set, the same operation mode can be repeated by simply pressing the ON/OFF button.

● **Operation buttons**

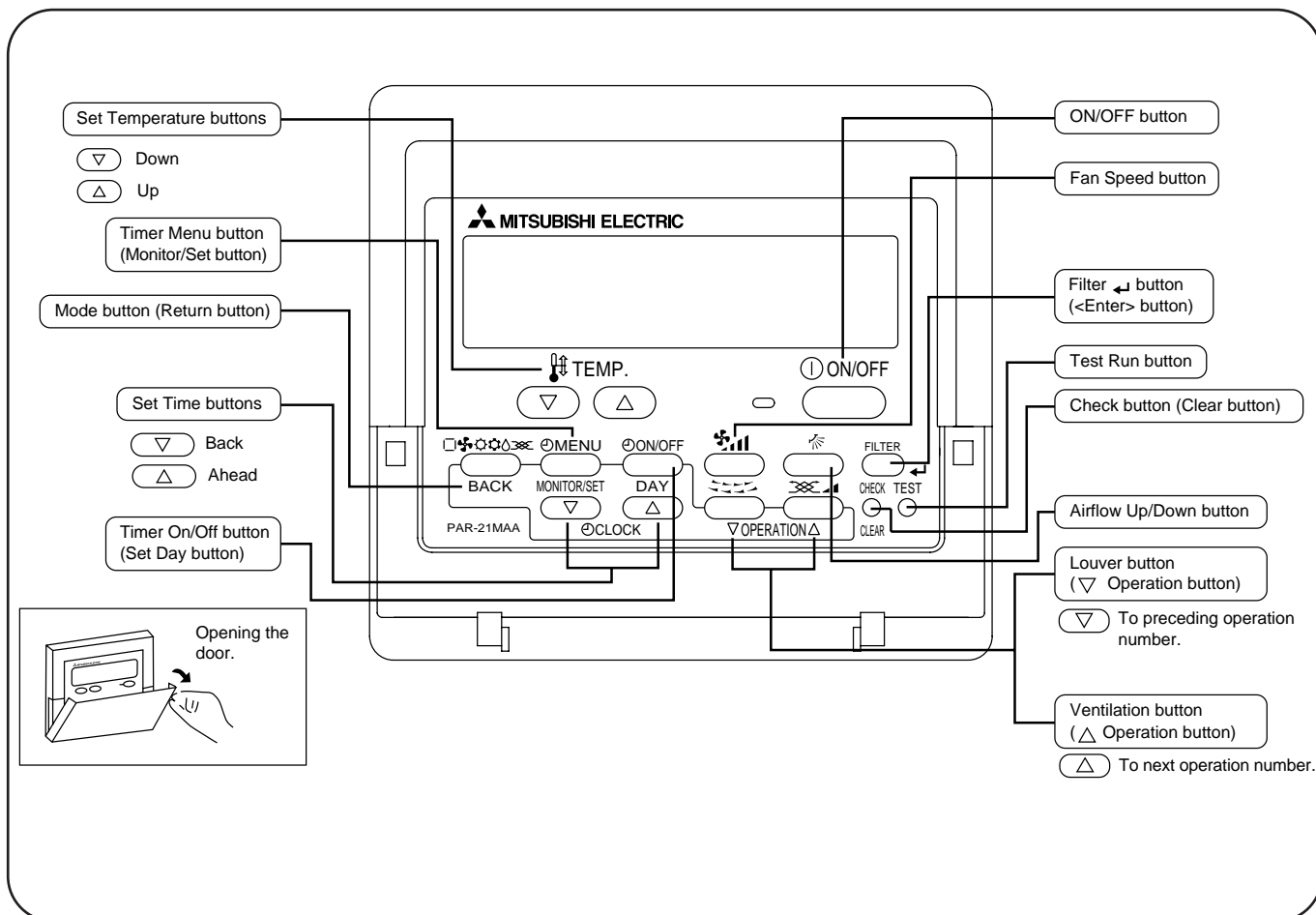

● Display

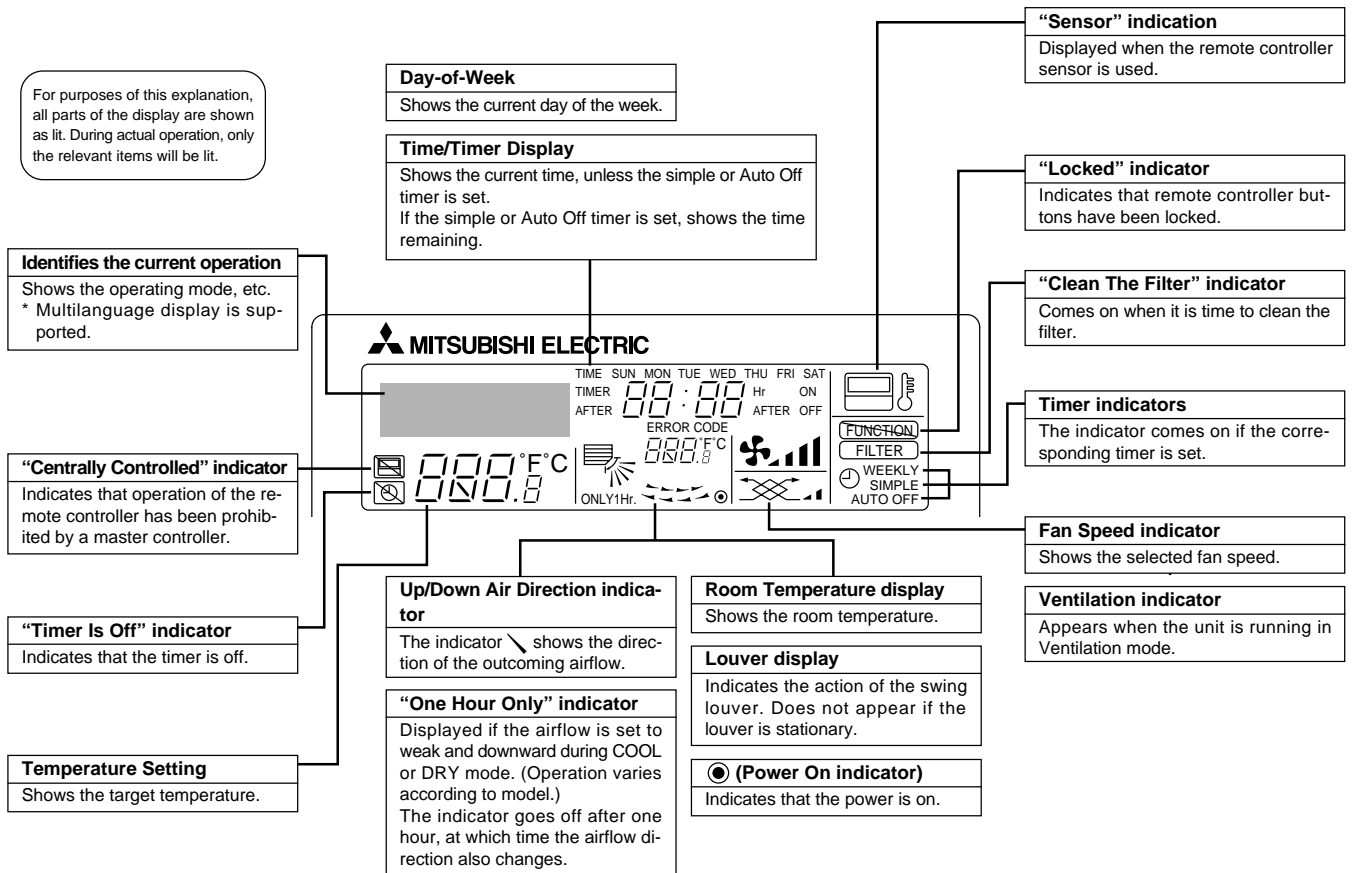

Caution

- Only the Power on indicator lights when the unit is stopped and power supplied to the unit.
- If you press a button for a feature that is not installed at the indoor unit, the remote controller will display the "Not Available" message.
If you are using the remote controller to drive multiple indoor units, this message will appear only if the feature is not present at the parent unit.
- When power is turned ON for the first time, it is normal that "PLEASE WAIT" is displayed on the room temperature indication (For max. 2minutes). Please wait until this "PLEASE WAIT" indication disappear then start the operation.

3

SPECIFICATIONS

3-1. SPECIFICATION

Item		Unit	PKFY-P63VFM-E	PKFY-P100VFM-E	
Power source		ϕ, V, Hz	Single phase, 220-230-240V, 50Hz / 220V, 60Hz		
Cooling capacity		kW	7.1	11.2	
Heating capacity		kW	8.0	12.5	
Electric characteristic	Input	Cooling	kW	0.12	0.14
		Heating	kW	0.12	0.14
	Current	Cooling	A	0.55	0.64
		Heating	A	0.55	0.64
Exterior <munsell symbol>		—	Plastic , white : <3.4Y 7.7/0.8>		
Dimensions	Height	mm	340	340	
	Width	mm	1,400	1,680	
	Depth	mm	235	235	
Heat exchanger		—	Cross fin(Aluminum plate fin and copper tube)		
Fan	Type X No.	—	Line flow fan X 2		
	Air flow High - Low	m ³ /min	20 - 15	28 - 22	
	External static pressure	Pa	0		
	Fan motor output	kW	0.04	0.07	
Insulator		—	Polyethylene sheet		
Air filter		—	PP Honeycomb fabric		
Pipe dimensions	Gas side	ϕ mm(in.)	15.88(5/8")	15.88(5/8") : R410A / 19.05(3/4") : R407C/ R22	
	Liquid side	ϕ mm(in.)	9.52(3/8")	9.52(3/8")	
Drain pipe dimension		ϕ mm	Drain socket (Accessory) O.D. 20 <PVC pipe VP-20 connectable>		
Noise level High - Low		dB	45 - 39	46 - 41	
Product weight		kg	24	28	

Note : Rating conditions (JIS B8616)

Cooling : Indoor	D.B. 27°C	W.B. 19.0°C
Outdoor	D.B. 35°C	W.B. 24°C
Heating : Indoor	D.B. 20°C	
Outdoor	D.B. 7°C	W.B. 6°C

3-2. ELECTRICAL PARTS SPECIFICATIONS

Service Ref. Parts name	Symbol	PKFY-P63VFM-E	PKFY-P100VFM-E
Room temperature thermistor	TH21	Resistance 0°C/15kΩ, 10°C/9.6kΩ, 20°C/6.3kΩ, 25°C/5.2kΩ, 30°C/4.3kΩ, 40°C/3.0kΩ	
Liquid pipe temperature thermistor	TH22	Resistance 0°C/15kΩ, 10°C/9.6kΩ, 20°C/6.3kΩ, 25°C/5.2kΩ, 30°C/4.3kΩ, 40°C/3.0kΩ	
Gas pipe temperature thermistor	TH23	Resistance 0°C/15kΩ, 10°C/9.6kΩ, 20°C/6.3kΩ, 25°C/5.2kΩ, 30°C/4.3kΩ, 40°C/3.0kΩ	
Fuse (Indoor controller board)	FUSE	250V 6.3A	
Fan motor (with inner-thermostat)	MF	D094P40MS 220-230-240V / 50Hz, 220V / 60Hz 4pole Output 40W	D10A4P70MS 220-230-240V / 50Hz, 220V / 60Hz 4pole Output 70W
		Inner-thermostat	OFF 130±5°C
Fan motor capacitor	C1	2.0μF 440V	3.0μF 440V
Vane motor	MV	MP 35 EA DC12V	
Linear expansion valve	LEV	DC12V Stepping motor drive Port dimension φ3.2 (0 ~ 2,000pulse)	DC12V Stepping motor drive Port dimension φ5.2 (0 ~ 2,000pulse)
Power supply terminal block	TB2	(L, N, ⊕) 330V 30A	
Transmission terminal block	TB5	(M1, M2, S) 250V 20A	
MA remote controller terminal block	TB15	(1,2) 250V 10A	
Dew prevention heater	H2	28.8W / 240V	

3-3. NOISE CRITERION CURVES

PKFY-P63VFM-E

NOTCH	SPL(dB)	LINE
High	45	○—○
Low	39	●—●

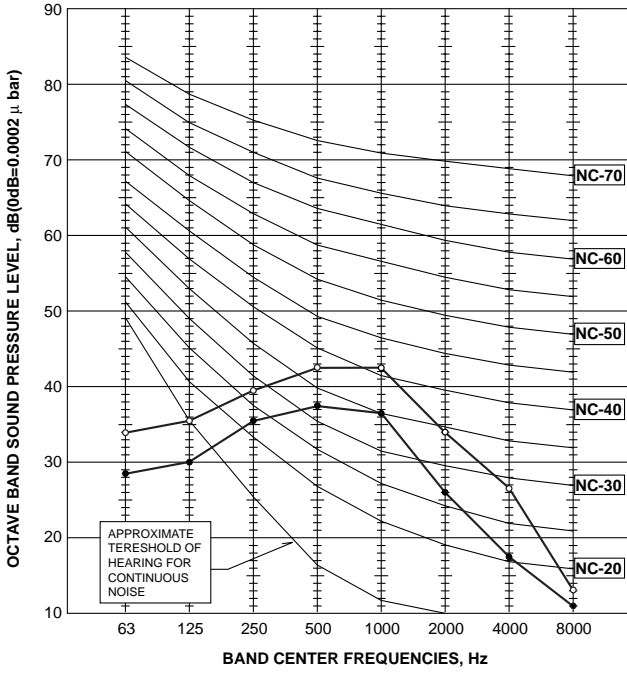

PKFY-P100VFM-E

NOTCH	SPL(dB)	LINE
High	46	○—○
Low	41	●—●

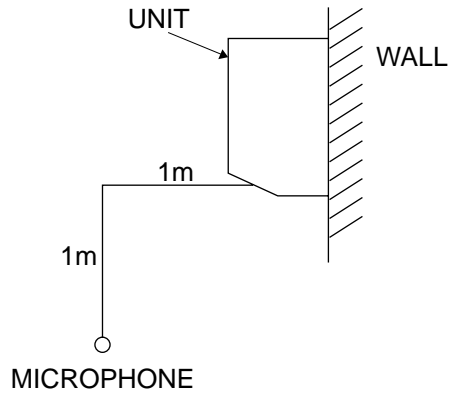
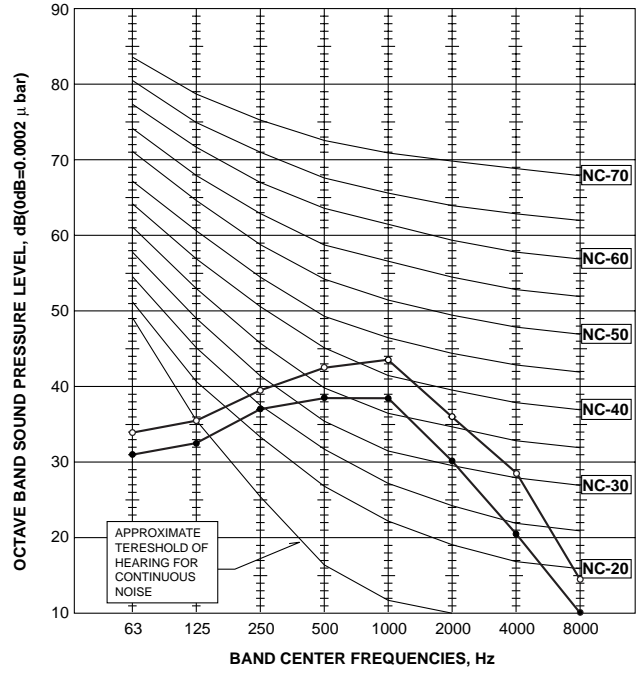

PKFY-P63VFM-E

Unit : mm

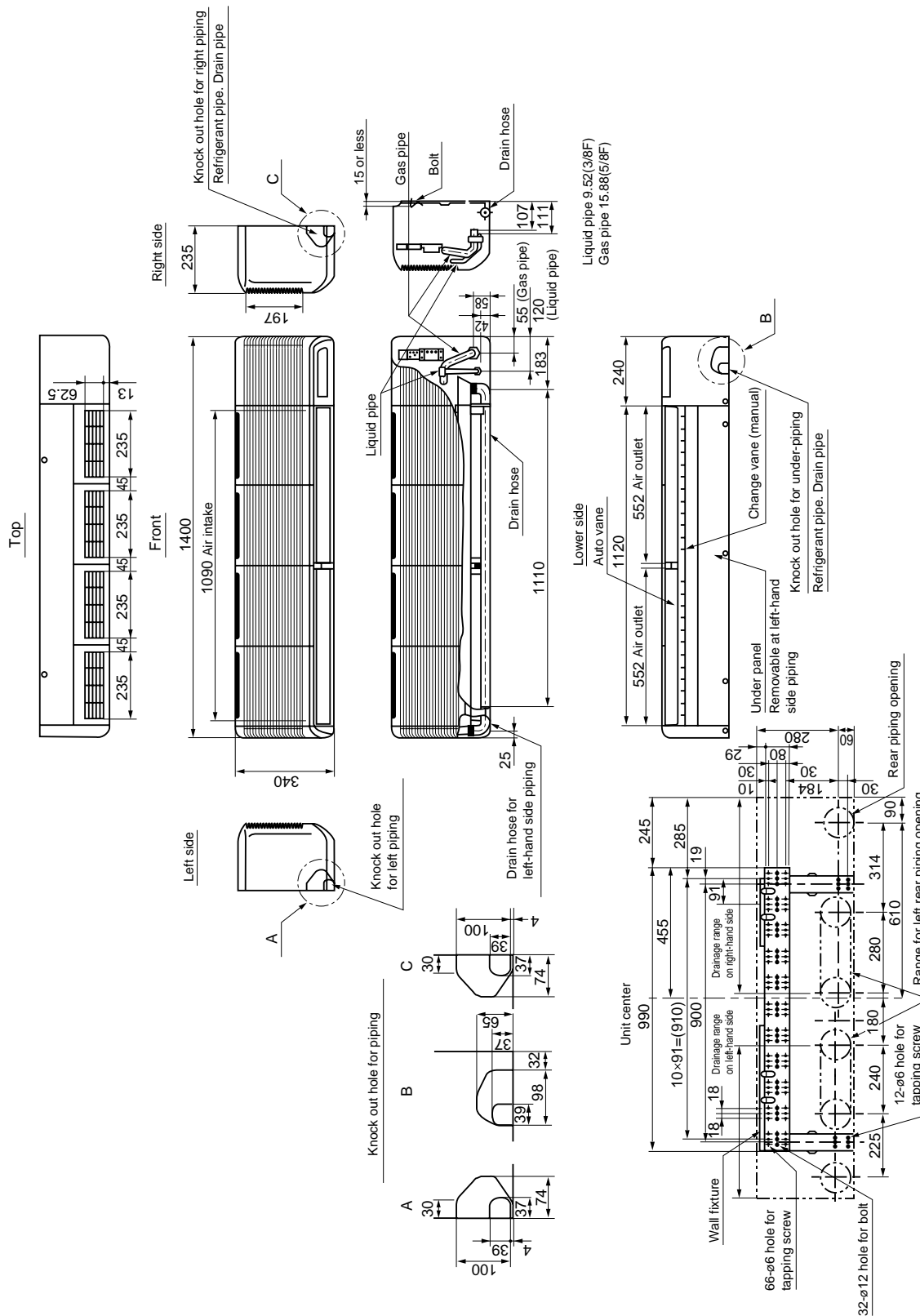

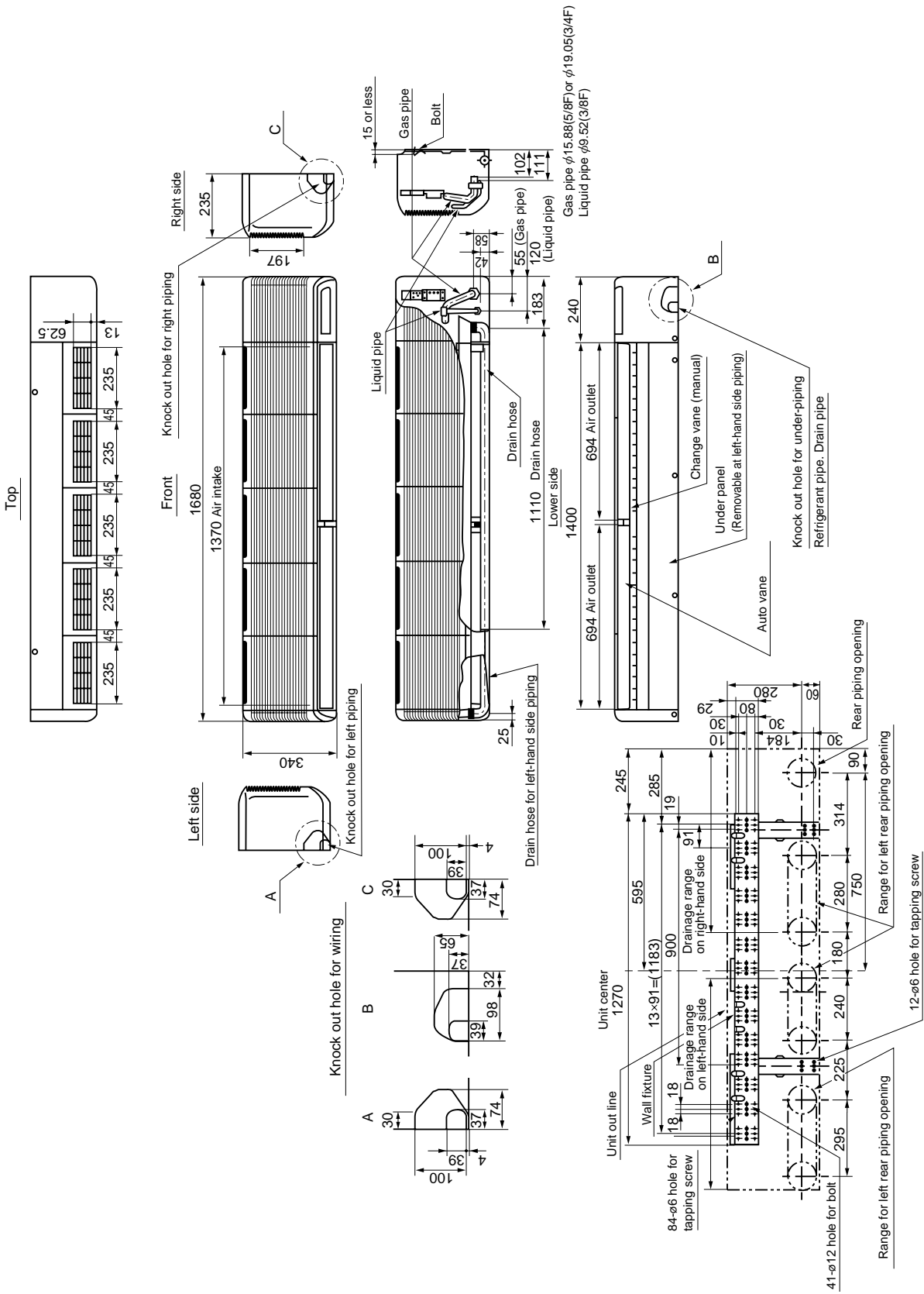

5

WIRING DIAGRAM

PKFY-P63VFM-E PKFY-P100VFM-E

Symbol	Name	Symbol	Name	Symbol	Name
I.B	Indoor controller board	C1	Capacitor (fan motor)	TH23	Thermistor
CN32	Connector	LEV	Linear expansion valve	A.B	Circuit board
CN41	Remote switch	MF	Fan motor (with inner thermo)	SW1	Switch
CN51	HA terminal-A	MV	Vane motor	SW5	Voltage selection
CN52	Centrally control	P.B	Indoor power board	SW11	Address setting 1st digit
F.C	Fan phase control	TB2	Terminal block	SW12	Address setting 2nd digit
FUSE	Fuse (6.3A/ 250V)	TB5	Terminal block	SW14	Connection No.
SW2	Switch	TB15	Terminal block	SWC	Option selector
SW3	Capacity code	TH21	Thermistor	I.B	CNP
SW4	Mode selection	TH22	Thermistor	X1	Connector
X4	Aux.Relay (Fan motor)			H2	Aux. Relay (D.Heater)
ZNR	Varistor				Dew prevention heater

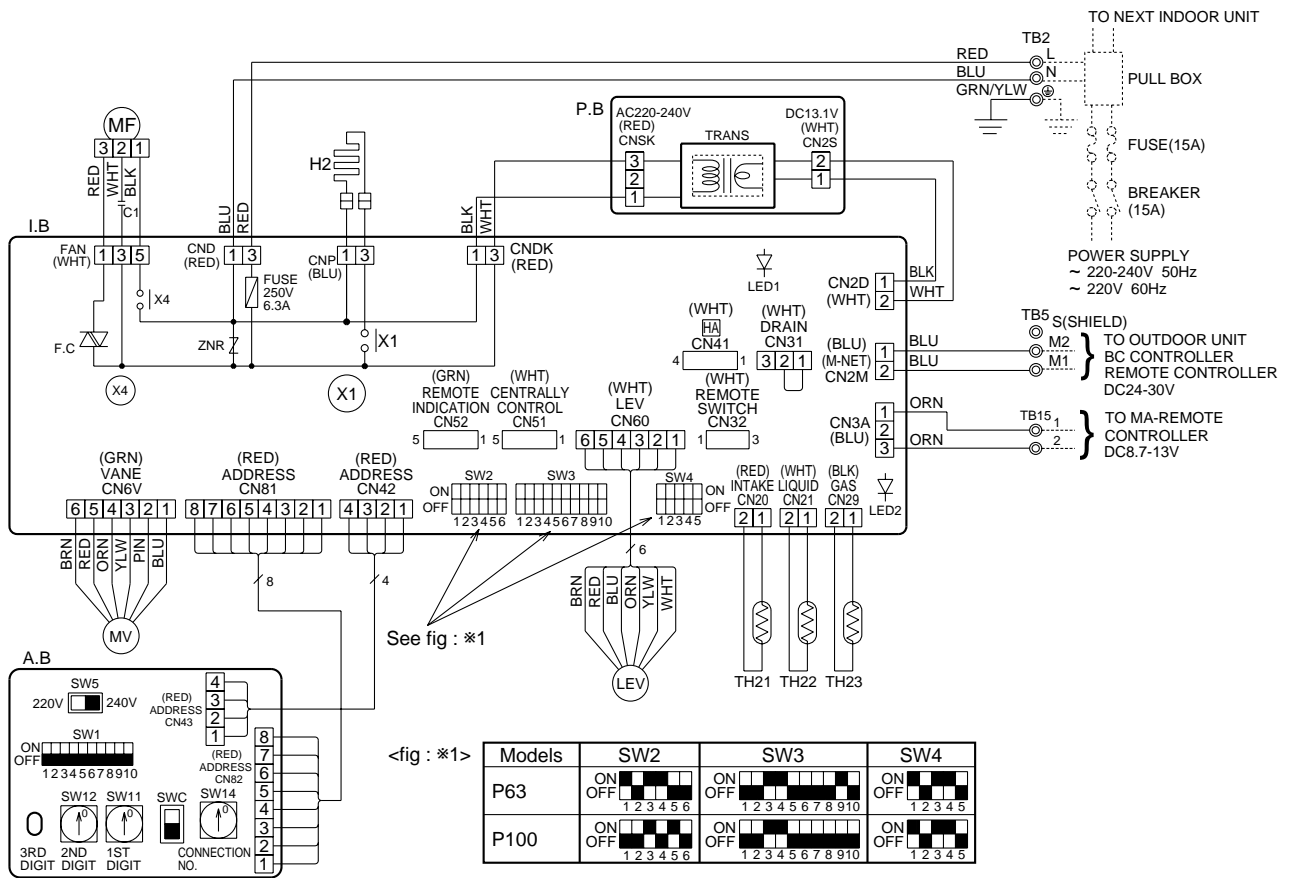

Note

- At servicing for outdoor unit, always follow the wiring diagram of outdoor unit.
- In case of using MA-Remote controller, please connect to TB15.
(Remote controller wire is non-polar.)
- In case of using M-NET, please connect to TB5.
(Transmission line is non-polar.)
- Symbol[S] of TB5 is the shield wire connection.
- Symbols used in wiring diagram above are, ⊙:terminal block, □□□:connector.
- The setting of the SW2 dip switches differs in the capacity for the detail, refer to the fig : *1.
- Please set the switch SW5 according to the power supply voltage.
Set SW5 to 240V side when the power supply is 230 and 240 volts.
When the power supply is 220 volts, set SW5 to 220V side.

LED on indoor board for service

Mark	Meaning	Function
LED1	Main power supply	Main power supply (Indoor unit : 220-240V) power on → lamp is lit
LED2	Power supply for MA-Remote controller	Power supply for MA-Remote controller on → lamp is lit

6

REFRIGERANT SYSTEM DIAGRAM

PKFY-P63VFM-E
 PKFY-P100VFM-E

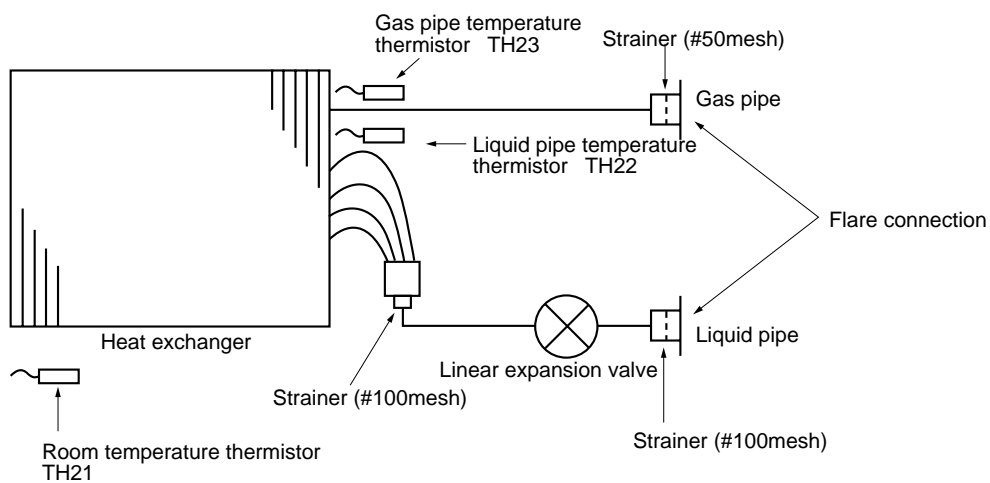

Item \ Capacity	PKFY-P63VFM-E	PKFY-P100VFM-E
Gas pipe	φ15.88 (5/8")	φ15.88 (5/8") or φ19.05 (3/4")
Liquid pipe	φ9.52 (5/8")	φ9.52 (3/8")

7-1. HOW TO CHECK

PKFY-P63VFM-E PKFY-P100VFM-E

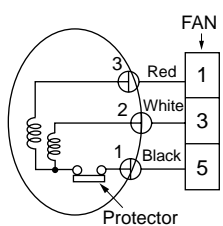
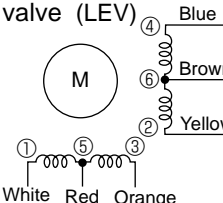
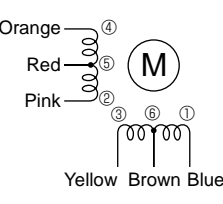
Parts name	Check points																		
Room temperature thermistor (TH21) Liquid pipe temperature thermistor (TH22) Gas pipe temperature thermistor (TH23)	Disconnect the connector then measure the resistance using a tester. (Surrounding temperature 10°C ~30°C) <table border="1" style="margin-left: 20px;"> <thead> <tr> <th>Normal</th> <th>Abnormal</th> </tr> </thead> <tbody> <tr> <td>4.3kΩ~9.6kΩ</td> <td>Open or short</td> </tr> </tbody> </table> (Refer to the next page for a detail.)	Normal	Abnormal	4.3kΩ~9.6kΩ	Open or short														
Normal	Abnormal																		
4.3kΩ~9.6kΩ	Open or short																		
Fan motor (MF) 	Measure the resistance between the terminals using a tester. (Surrounding temperature 20°C) <table border="1" style="margin-left: 20px;"> <thead> <tr> <th rowspan="2">Motor terminal or Relay connector</th> <th colspan="2">Normal</th> <th rowspan="2">Abnormal</th> </tr> <tr> <th>PKFY-P63VFM-E</th> <th>PKFY-P100VFM-E</th> </tr> </thead> <tbody> <tr> <td>Red-Black</td> <td>99.5Ω ±10%</td> <td>62.6Ω ±10%</td> <td rowspan="2">Open or short</td> </tr> <tr> <td>White-Black</td> <td>103.5Ω ±10%</td> <td>74.0Ω ±10%</td> </tr> </tbody> </table>	Motor terminal or Relay connector	Normal		Abnormal	PKFY-P63VFM-E	PKFY-P100VFM-E	Red-Black	99.5Ω ±10%	62.6Ω ±10%	Open or short	White-Black	103.5Ω ±10%	74.0Ω ±10%					
Motor terminal or Relay connector	Normal		Abnormal																
	PKFY-P63VFM-E	PKFY-P100VFM-E																	
Red-Black	99.5Ω ±10%	62.6Ω ±10%	Open or short																
White-Black	103.5Ω ±10%	74.0Ω ±10%																	
Linear expansion valve (LEV) 	Disconnect the connector then measure the resistance valve using a tester. (Surrounding temperature 20°C) <table border="1" style="margin-left: 20px;"> <thead> <tr> <th colspan="4">Normal</th> <th rowspan="2">Abnormal</th> </tr> <tr> <th>(1)-(5)</th> <th>(2)-(6)</th> <th>(3)-(5)</th> <th>(4)-(6)</th> </tr> </thead> <tbody> <tr> <td>White-Red</td> <td>Yellow-Brown</td> <td>Orange-Red</td> <td>Blue-Brown</td> <td rowspan="2">Open or short</td> </tr> <tr> <td colspan="4" style="text-align: center;">200kΩ ±10%</td> </tr> </tbody> </table> (Refer to the next page for a detail.)	Normal				Abnormal	(1)-(5)	(2)-(6)	(3)-(5)	(4)-(6)	White-Red	Yellow-Brown	Orange-Red	Blue-Brown	Open or short	200kΩ ±10%			
Normal				Abnormal															
(1)-(5)	(2)-(6)	(3)-(5)	(4)-(6)																
White-Red	Yellow-Brown	Orange-Red	Blue-Brown	Open or short															
200kΩ ±10%																			
Vane motor (MV) 	Measure the resistance between the terminals using a tester. (Surrounding temperature 20°C ~30°C) <table border="1" style="margin-left: 20px;"> <thead> <tr> <th>Connector</th> <th>Normal</th> <th>Abnormal</th> </tr> </thead> <tbody> <tr> <td>Brown — Yellow</td> <td rowspan="4">186~214Ω</td> <td rowspan="4">Open or short</td> </tr> <tr> <td>Brown — Blue</td> </tr> <tr> <td>Red — Orange</td> </tr> <tr> <td>Red — Pink</td> </tr> </tbody> </table>	Connector	Normal	Abnormal	Brown — Yellow	186~214Ω	Open or short	Brown — Blue	Red — Orange	Red — Pink									
Connector	Normal	Abnormal																	
Brown — Yellow	186~214Ω	Open or short																	
Brown — Blue																			
Red — Orange																			
Red — Pink																			
Dew prevention heater (H2)	Disconnect the connector then measure the resistance using a tester. <table border="1" style="margin-left: 20px;"> <thead> <tr> <th>Normal</th> <th>Abnormal</th> </tr> </thead> <tbody> <tr> <td>2kΩ ±5%</td> <td>Open or short</td> </tr> </tbody> </table>	Normal	Abnormal	2kΩ ±5%	Open or short														
Normal	Abnormal																		
2kΩ ±5%	Open or short																		

<Thermistor Characteristic graph>

Thermistor for lower temperature

- Room temperature thermistor (TH21)
- Liquid pipe temperature thermistor (TH22)
- Gas pipe temperature thermistor (TH23)

Thermistor $R_0=15k\Omega \pm 3\%$
 Fixed number of $B=3480 \pm 2\%$

$$R_t = 15 \exp \left\{ 3480 \left(\frac{1}{273+t} - \frac{1}{273} \right) \right\}$$

0°C	15kΩ
10°C	9.6kΩ
20°C	6.3kΩ
25°C	5.2kΩ
30°C	4.3kΩ
40°C	3.0kΩ

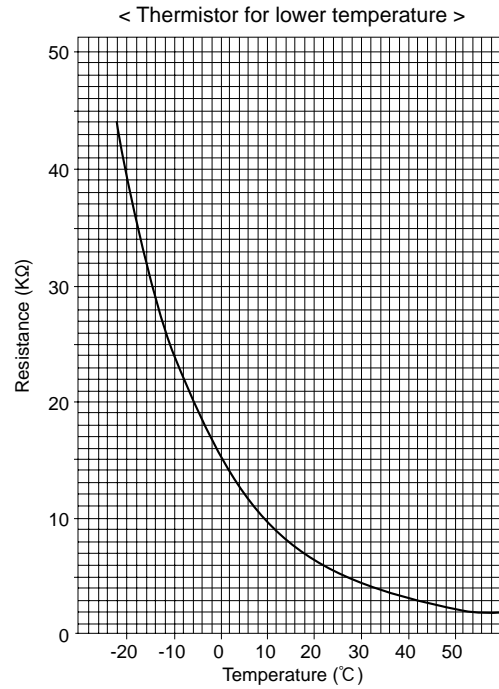

Linear expansion valve

① Operation summary of the linear expansion valve.

- Linear expansion valve open/close through stepping motor after receiving the pulse signal from the indoor controller board.
- Valve position can be changed in proportion to the number of pulse signal.

<Connection between the indoor controller board and the linear expansion valve>

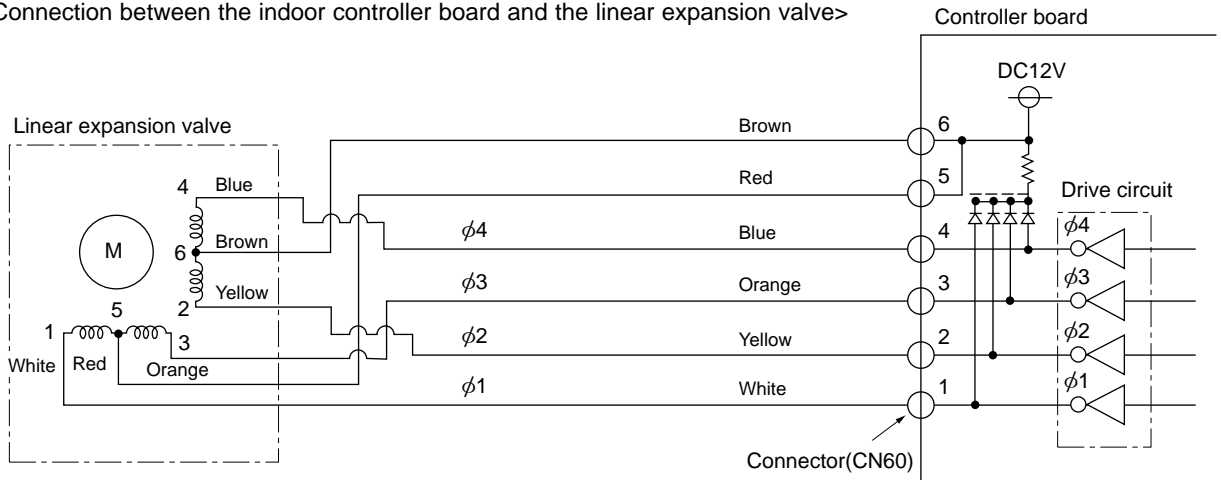

<Output pulse signal and the valve operation>

Output (Phase)	Output			
	1	2	3	4
φ1	ON	OFF	OFF	ON
φ2	ON	ON	OFF	OFF
φ3	OFF	ON	ON	OFF
φ4	OFF	OFF	ON	ON

Closing a valve : 1 → 2 → 3 → 4 → 1
 Opening a valve : 4 → 3 → 2 → 1 → 4

The output pulse shifts in above order.

- * 1. When linear expansion valve operation stops, all output phase become OFF.
- 2. At phase interruption or when phase does not shift in order, motor does not rotate smoothly and motor locks and vibrates.

② Linear expansion valve operation

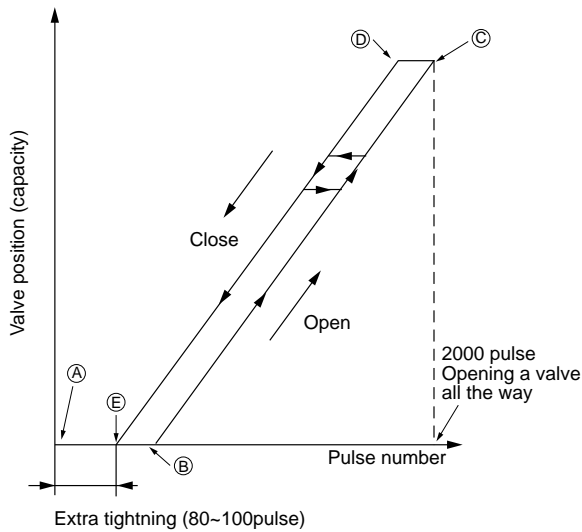

- * When the switch is turned on, 2200 pulse closing valve signal will be send till it goes to A point in order to define the valve position.

When the valve move smoothly, there is no noise or vibration occurring from the linear expansion valve : however, when the pulse number moves from E to A or when the valve is locked, more noise can be heard than normal situation.

- * Noise can be detected by placing the ear against the screw driver handle while putting the screw driver to the linear expansion valve.



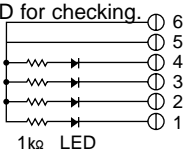
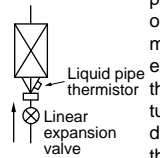



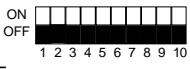

③ Trouble shooting

Symptom	Check points	Countermeasures
Operation circuit failure of the micro processor.	Disconnect the connector on the controller board, then connect LED for checking.  Pulse signal will be sent out for 10 seconds as soon as the main switch is turned on. If there is LED with lights on or lights off, it means the operation circuit is abnormal.	Exchange the indoor controller board at drive circuit failure.
Linear expansion valve mechanism is locked.	Motor will idle and make ticking noise when motor is operated while the linear expansion valve is locked. This ticking sound is the sign of the abnormality.	Exchange the linear expansion vale.
Short or breakage of the motor coil of the linear expansion valve.	Measure the resistance between the each coil (red-white, red-orange, brown-yellow, brown-blue) using a tester. It is normal if the resistance is in the range of 150Ω±10%.	Exchange the linear expansion valve.
Valve doesn't close completely.	To check the linear expansion valve, operate the indoor unit in fan mode and at the same time operate other indoor units in cooling mode, then check the pipe temperature <liquid pipe temperature> of the indoor unit by the outdoor multi controller board operation monitor. During fan operation, linear expansion valve is closed completely and if there are some leaking, detecting temperature of the thermistor will go lower. If the detected temperature is much lower than the temperature indicated in the remote controller, it means the valve is not closed all the way. It is not necessary to exchange the linear expansion valve, if the leakage is small and not making any trouble. 	If large amount of thermistor is leaked, exchange the linear expansion valve.
Wrong connection of the connector or contact failure.	Check the color of lead wire and missing terminal of the connector.	Disconnect the connector at the controller board, then check the continuity.

7-2. FUNCTION OF DIP SWITCH

PKFY-P63VFM-E

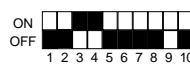
PKFY-P100VFM-E

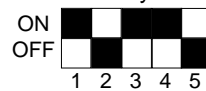
Switch	Pole	Function	Operation by switch		Remarks									
			ON	OFF										
SW1 Mode Selection	1	Thermistor<Intake temperature detection>position	Built-in remote controller	Indoor unit	<div style="border: 1px solid black; padding: 5px;">Address board</div> <p><At delivery></p>  <p>NOTE:</p> <ul style="list-style-type: none"> *1 At Heating mode, fan operating. *2 At Heating mode, operating heat thermostat ON. *3 SW1-7=OFF, SW1-8=ON →Setting air flow. SW1-7=ON, SW1-8=ON →Indoor fan stop. 									
	2	Filter clogging detection	Provided	Not provided										
	3	Filter cleaning sign	2500hr	100hr										
	4	Air intake	Effective	Not effective										
	5	Remote indication switching	Thermostat ON signal indication	Fan output indication										
	6	Humidifier control	Always operated while the heating mode	Operated depends on the condition										
	7	Air flow set in case of	Fix to LOW	Fix to EXTRA LOW										
	8	Heat thermostat OFF	Depends on setting remote controller	Depends on SW1-7										
	9	Auto restart	Effective	Not effective										
	10	Power source ON/OFF	Effective	Not effective										
SW2 Capacity code setting	1~6	<table border="1" style="width: 100%; text-align: center;"> <thead> <tr> <th>MODELS</th> <th>SW2</th> <th>MODELS</th> <th>SW2</th> </tr> </thead> <tbody> <tr> <td>PKFY-P63VFM-E</td> <td>ON OFF </td> <td>PKFY-P100VFM-E</td> <td>ON OFF </td> </tr> </tbody> </table>				MODELS	SW2	MODELS	SW2	PKFY-P63VFM-E	ON OFF 	PKFY-P100VFM-E	ON OFF 	<div style="border: 1px solid black; padding: 5px;">Indoor controller board</div> <p>Set while the unit is off.</p> <p><At delivery></p> <p>Set for each capacity.</p>
		MODELS	SW2	MODELS	SW2									
PKFY-P63VFM-E	ON OFF 	PKFY-P100VFM-E	ON OFF 											
SW3 Function Selection	1	Heat pump/Cooling only	Cooling only model	Heat pump model	<div style="border: 1px solid black; padding: 5px;">Indoor controller board</div> <p>Set while the unit is off.</p> <p><At delivery></p>  <p>NOTE:</p> <ul style="list-style-type: none"> *4 At cooling mode, each angle can be used only 1 hour. *5 sw3-9 setting PKFY-P63VFM-E = ON PKFY-P100VFM-E = OFF 									
2	Louver	Available	Not available											
3	Vane	Available	Not available											
4	Vane swing function	Available	Not available											
5	Vane horizontal angle	Second setting	First setting											
6	Vane cooling limit angle setting	Horizontal angle	Down B,C											
7	Indoor linear expansion valve opening	Effective	Not effective											
8	Heater 4degrees up	Not effective	Effective											
9	Target Superheat setting	9degrees	6degrees											
10	Target Sub cool setting	15degrees	10degrees											
SW4 Unit Selection	1~5					<div style="border: 1px solid black; padding: 5px;">Indoor controller board</div> <p>Set while the unit is off.</p> <p><At delivery></p> 								



Switch	Pole	Operation by switch	Remarks
SW11 1st digit address setting SW12 2nd digit address setting	Rotary switch	<p>Address setting should be done when M-NET remote controller is being used.</p>	<div style="border: 1px solid black; padding: 2px; text-align: center;">Address board</div> <p>Address can be set while the unit is stopped.</p> <p><At delivery></p>
SW14 Connect ion No. setting	Rotary switch	<p>This is the switch to be used when the indoor unit is operated with R2 series outdoor unit as a set.</p>	<div style="border: 1px solid black; padding: 2px; text-align: center;">Address board</div> <p><At delivery></p>
SW5 Voltage Selection	2	<p>If the unit is used at the 230V or 240V area, set the voltage to 240V. If the unit is used at the 220V, set the voltage to 220V.</p>	<div style="border: 1px solid black; padding: 2px; text-align: center;">Address board</div> <p><At delivery></p> <p>220V 240V</p>

7-3. TEST POINT DIAGRAM

7-3-1. Indoor controller board

PKFY-P63VFM-E

PKFY-P100VFM-E

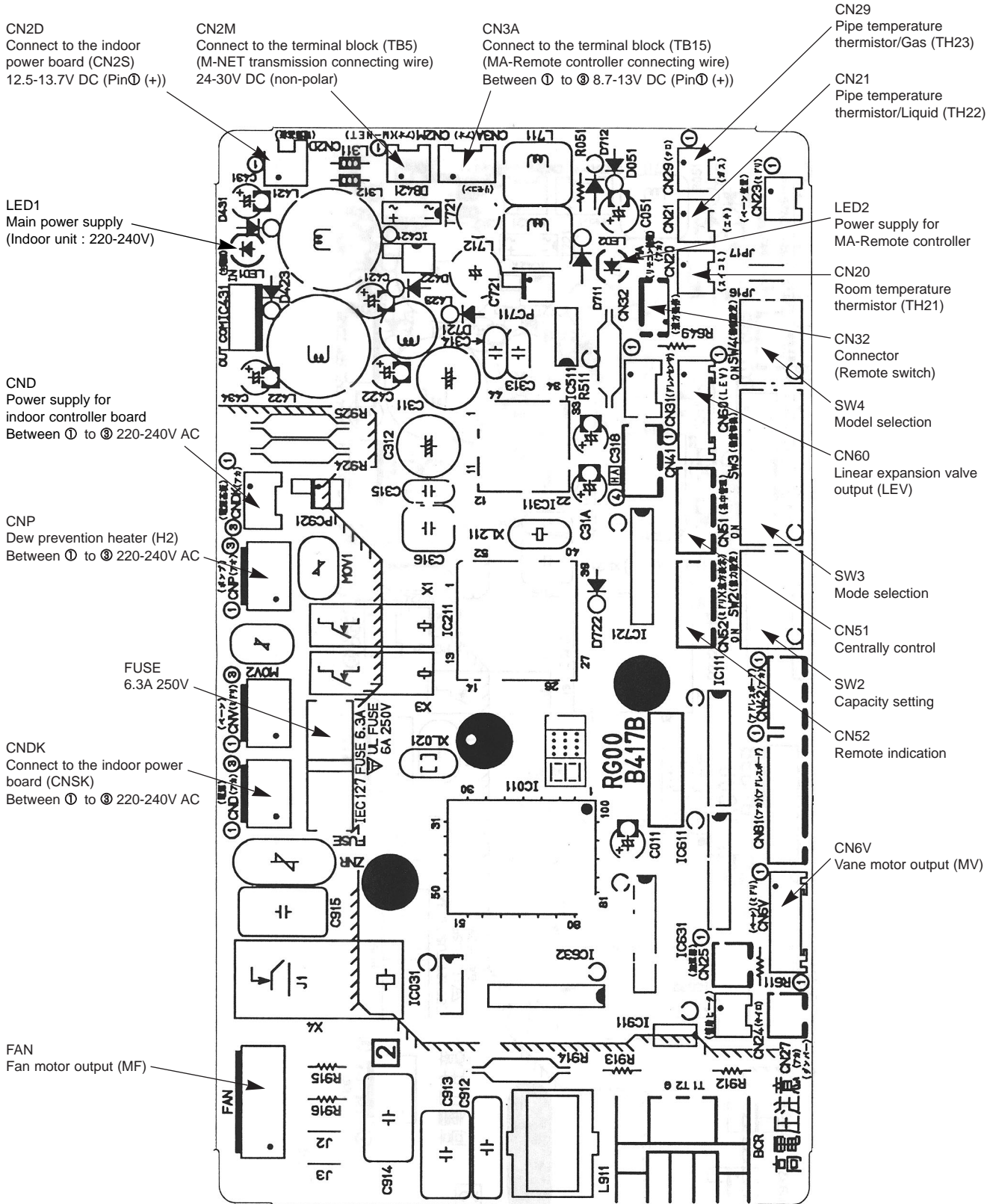

7-3-2. Indoor power board
 PKFY-P63VFM-E
 PKFY-P100VFM-E

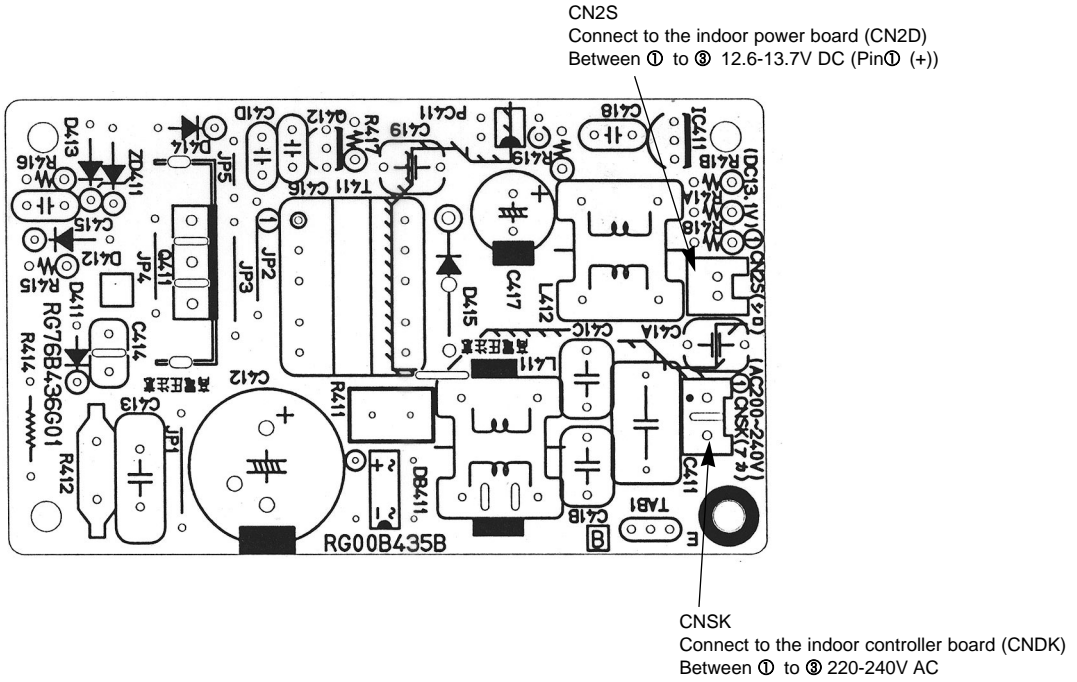

PKFY-P63VFM-E PKFY-P100VFM-E

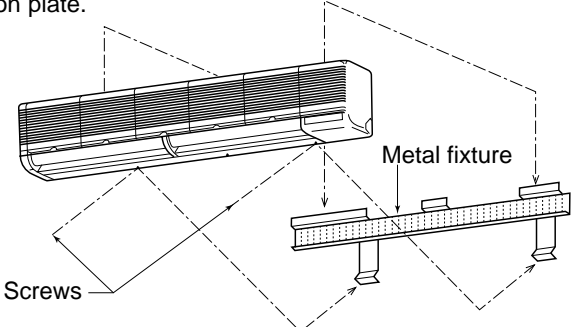
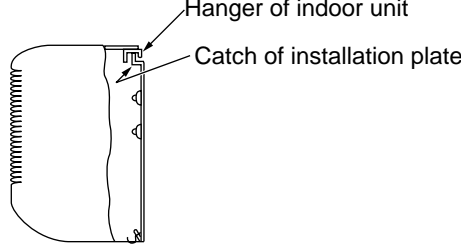
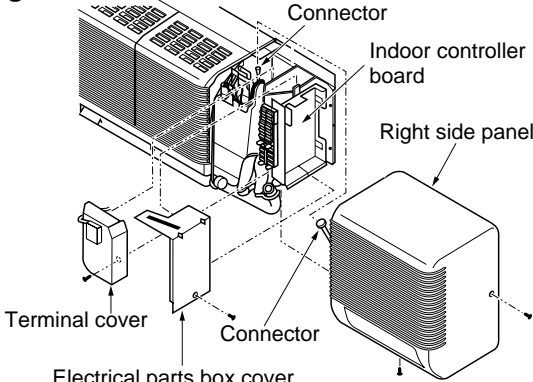
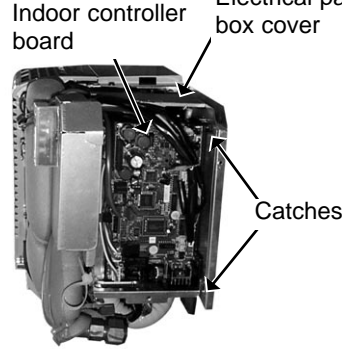
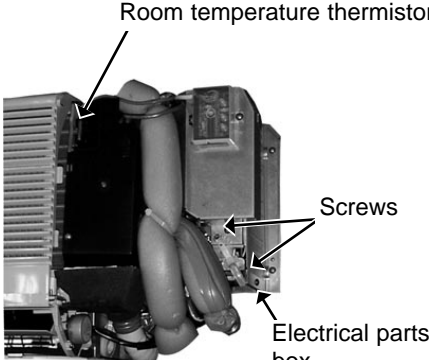
OPERATING PROCEDURE	PHOTOS & ILLUSTRATION
<p>1. Removing the lower side of the indoor unit from the installation plate</p> <p>(1) Remove the 2 screws. Hang the indoor unit hangers to the catches on the installation plate.</p> 	<p>Figure 1</p>  <p>Hanger of indoor unit Catch of installation plate</p>
<p>2. Removing the right side panel</p> <p>(1) Remove the 2 screws of the right side panel: one on the bottom and the other on the upper right-hand side. (2) Disconnect the connector from the adapter case. (3) Sliding the right side panel to the right, pull it out toward you.</p>	<p>Figure 2</p>  <p>Connector Indoor controller board Right side panel Terminal cover Connector Electrical parts box cover</p>
<p>3. Removing the indoor controller board</p> <p>(1) Remove the right side panel. (2) Remove the screw of the electrical parts box cover, and remove the cover. (3) Disconnect the connectors on the indoor controller board. (4) To unhook the catches on the right-hand side of the indoor controller board, pull the left-hand side toward you and lift up the cover to the right. Then the indoor controller board can be removed.</p>	<p>Photo 1</p>  <p>Indoor controller board Electrical parts box cover Catches</p>
<p>4. Removing the electrical parts box</p> <p>(1) Remove the right side panel. (2) Remove the screw of the electrical parts box cover and controller cover, and remove each the cover. (3) Disconnect the vane motor, the linear expansion valve, the room temperature thermistor, the liquid pipe temperature thermistor and the gas pipe temperature thermistor connector on the indoor controller board. (4) Remove the 2 screws of the electrical parts box. (5) Disconnect the connector of the fan motor lead wire. (Fan motor side) (6) Remove the electrical parts box.</p>	<p>Photo 2</p>  <p>Room temperature thermistor Screws Electrical parts box</p>

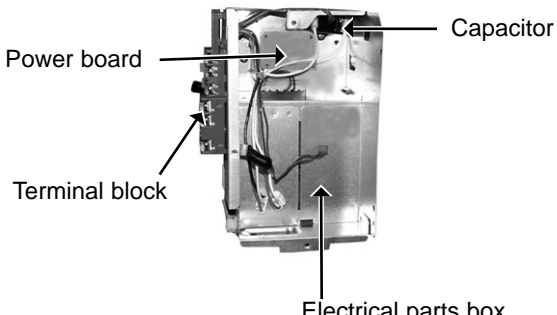
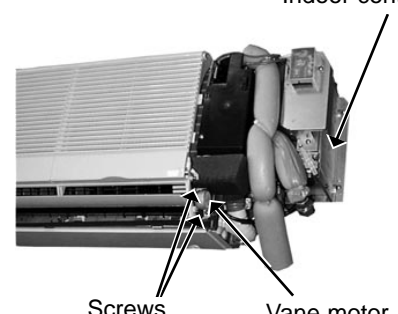
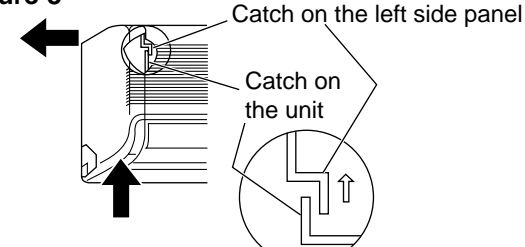
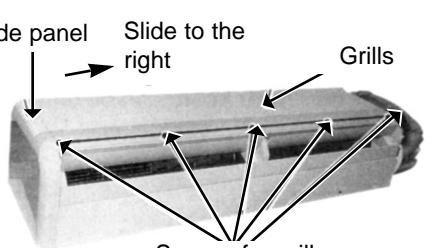
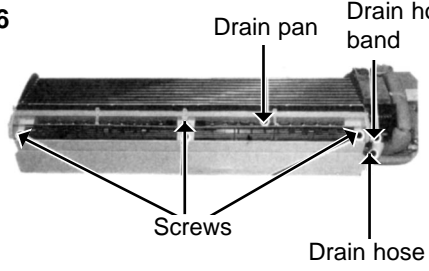

OPERATING PROCEDURE	PHOTOS & ILLUSTRATION
<p>(7) Remove the indoor controller board case. Then the Power board and the capacitor can be serviced.</p>	<p>Photo 3</p>  <p>Power board Terminal block Capacitor Electrical parts box</p>
<p>5. Removing the vane motor</p> <ol style="list-style-type: none">(1) Remove the right side panel.(2) Remove the screw of the electrical parts box cover, and remove the terminal cover.(3) Remove the 2 screws of the vane motor, and remove the motor from the shaft.(4) Disconnect the vane motor connector on the indoor controller board.	<p>Photo 4</p>  <p>Indoor controller board Screws Vane motor</p>
<p>6. Removing the intake grilles</p> <ol style="list-style-type: none">(1) Remove the right side panel.(2) To remove the left side panel, remove the screw on the bottom and the screw on the upper left-hand side. (See Figure 3.)<ol style="list-style-type: none">1. Press up this side of the left side panel to unhook the catch on the panel from the catch on the unit.2. Slide the left side panel to the left to remove the panel. <p>Note: Fix the unit to the metal fixture securely</p> <ol style="list-style-type: none">(3) Remove the air filters.(4) Hold and press the center cover to remove.(5) Remove the screws of the grilles.(6) Pull the lower side of the grille toward you and slide the upper to the right to remove the grilles.	<p>Figure 3</p>  <p>Catch on the left side panel Catch on the unit</p> <p>Photo 5</p>  <p>Left side panel Slide to the right Grilles Screws for grilles</p>
<p>7. Removing the drain pan</p> <ol style="list-style-type: none">(1) Remove the left and right side panels.(2) Remove the grilles.(3) Remove the electrical parts box cover.(4) Loosen the drain hose band to remove.(5) Remove the 3 screws of the drain pan, and slide the drain pan toward you to remove.	<p>Photo 6</p>  <p>Drain pan Drain hose band Screws Drain hose</p>

OPERATING PROCEDURE

8. Removing the lineflow fan and the fan motor

- (1) Remove the left and right side panels.
- (2) Remove the grilles.
- (3) Remove the electrical parts box.
- (4) Remove the drain pan.
- (5) Loosen the screw that fixes the lineflow fan to the fan motor. (See Photo 7.)
- (6) Remove the 4 screws of the motor fixture, and remove the fan motor and the motor fixture at a time (See Photo 8.)
- (7) Remove the screws of the left and right motor supports, and remove the motor supports and the fan motor. (See Photo 9.)
- (8) Remove the screw of the center support, and remove the support. (See Photo 10.)
- (9) Remove the 2 screws on the left and right sides of the heat exchanger, and pull the bearing support toward you. (See Photo 11.)
- (10) Pull the left-hand side of the heat exchanger toward you, and remove the lineflow fan.

Photo 11

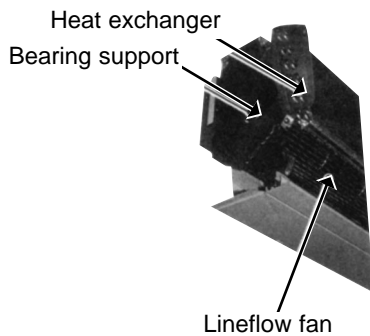

PHOTOS

Photo 7

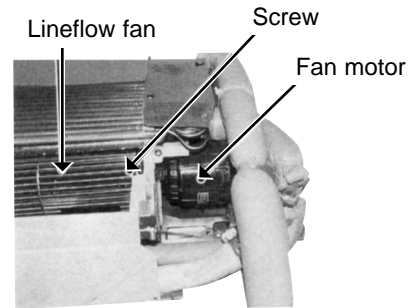

Photo 8

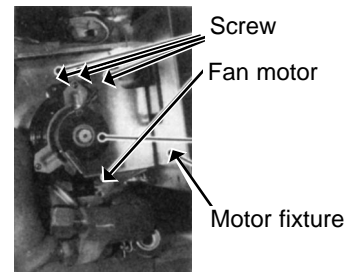

Photo 9

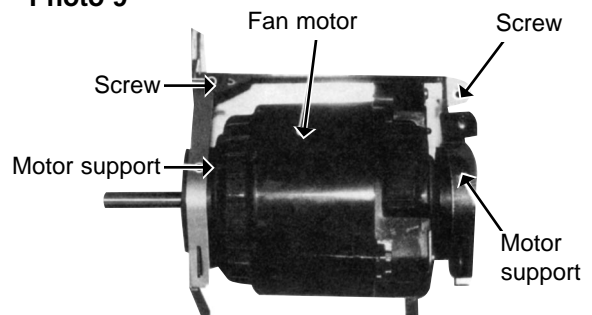
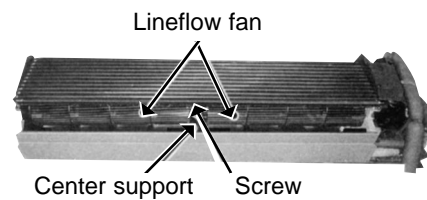

Photo 10



9

PARTS LIST (non-RoHS compliant)

STRUCTURAL PARTS

PKFY-P63VFM-E

PKFY-P100VFM-E

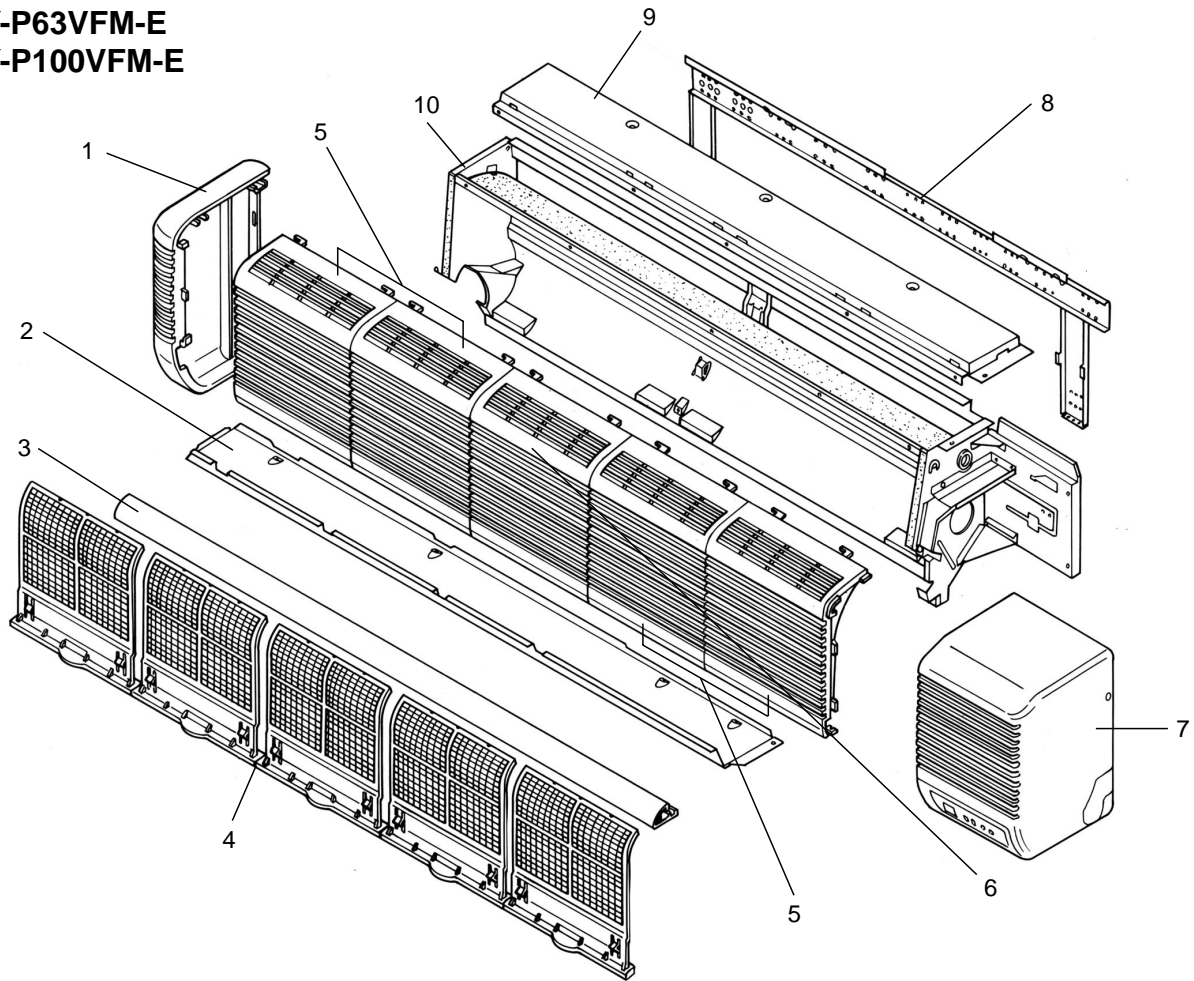

Part number that is circled is not shown in the figure.

No.	Part No.	Part Name	Specification	Q'ty / set		Remarks (Drawing No.)	Wiring Diagram Symbol	Recom- mended Q'ty	Price	
				PKFY-P•VFM-E					Unit	Amount
				63	100					
1	R01 12G 662	LEFT SIDE PANEL		1	1					
2	R01 E01 812	UNDER PLATE		1						
	R01 E00 812	UNDER PLATE			1					
3	R01 E00 811	NOSE		1						
	R01 E01 811	NOSE			1					
4	R01 A17 500	AIR FILTER		4	5					
5	R01 12G 691	INTAKE GRILLE		2	2					
6	R01 16G 692	INTAKE GRILLE			1					
7	R01 12G 661	RIGHT SIDE PANEL		1	1					
8	R01 12G 808	BACK PLATE		1						
	R01 16G 808	BACK PLATE			1					
9	R01 E01 641	TOP PLATE		1						
	R01 E00 641	TOP PLATE			1					
10	—	BOX ASSEMBLY		1		(RG00A734GJ3)				
	—	BOX ASSEMBLY			1	(RG00A734GJ4)				
⑪	R01 12G 523	DRAIN SOCKET		1	1					

ELECTRICAL PARTS
PKFY-P63VFM-E
PKFY-P100VFM-E

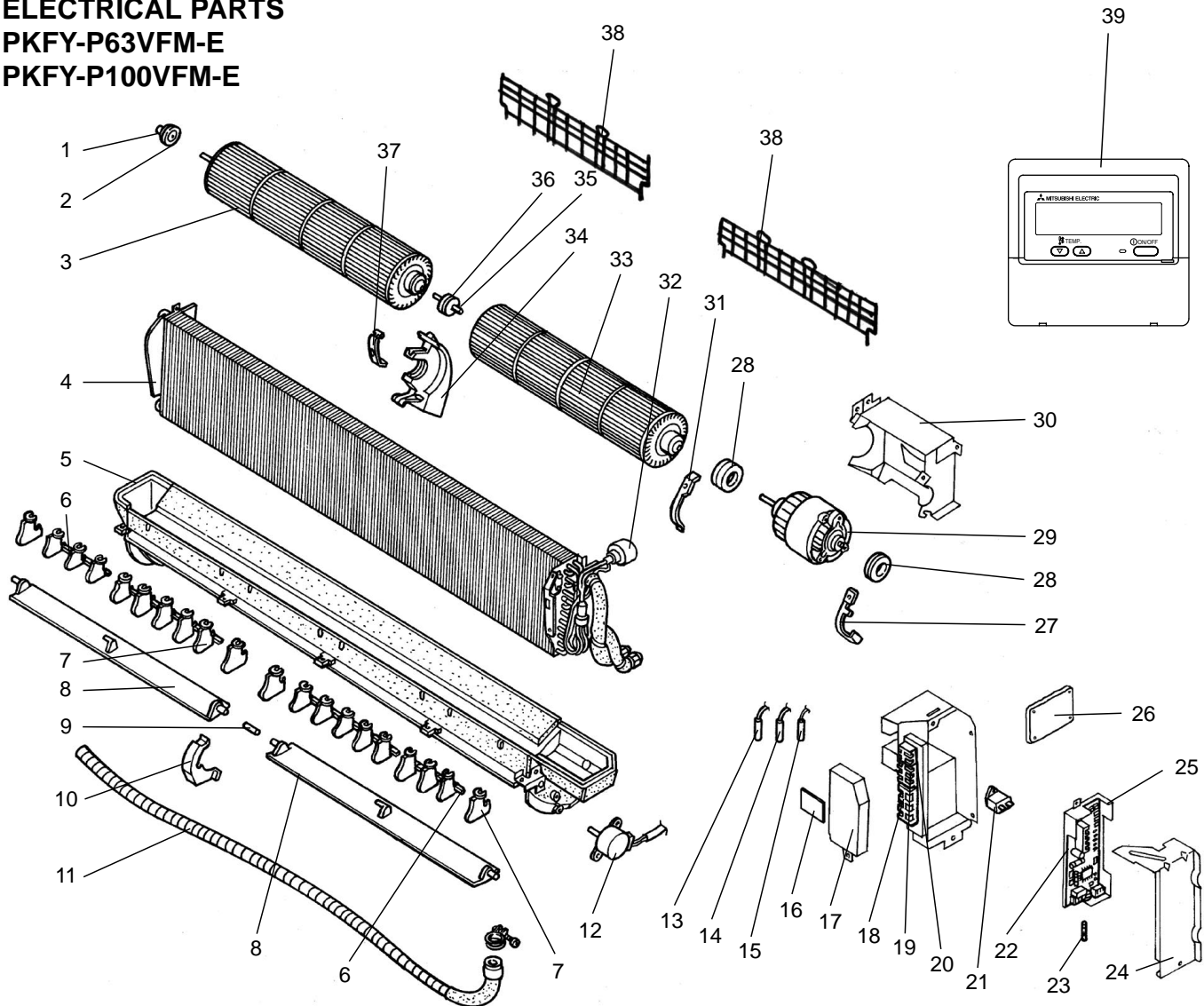

No.	Part No.	Part Name	Specification	Q'ty / set		Remarks (Drawing No.)	Wiring Diagram Symbol	Recom- mended Q'ty	Price	
				PKFY-P•VFM-E					Unit	Amount
				63	100					
1	R01 Z61 102	BEARING MOUNT		1	1					
2	R01 005 103	SLEEVE BEARING		1	1					
3	R01 13G 114	LEFT LINEFLOW FAN		1						
	R01 17G 114	LEFT LINEFLOW FAN			1					
4	T7W K28 480	HEAT EXCHANGER		1						
	T7W K29 480	HEAT EXCHANGER			1					
5	T7W E13 529	DRAIN PAN		1						
	T7W E14 529	DRAIN PAN			1					
6	—	ARM		3	4	(BG25H301H02)				
7	—	GUIDE VANE		16	22	(BG25J821H01)				
	—	GUIDE VANE (WITH HANDELE)		4	4	(BG25J821H02)				
	—	GUIDE VANE (WITH HANDELE)		4	4	(BG25J821H02)				
8	R01 12G 002	AUTO VANE		2						
	R01 16G 002	AUTO VANE			2					
9	R01 12G 063	JOINT SHAFT		1	1					
10	R01 12G 621	CENTER COVER		1	1					
11	R01 KV5 527	DRAIN HOSE		1	1					

Part number that is circled is not shown in the figure.

No.	Part No.	Part Name	Specification	Q'ty / set		Remarks (Drawing No.)	Wiring Diagram Symbol	Recom- mended Q'ty	Price	
				PKFY-P•VFM-E					Unit	Amount
				63	100					
12	T7W E03 223	VANE MOTOR		1	1		MV			
13	R01 E32 202	GAS PIPE THERMISTOR		1	1		TH23			
14	T7W E12 202	ROOM TEMPERATURE THERMISTOR		1	1		TH21			
15	R01 E02 202	LIQUID PIPE THERMISTOR		1	1		TH22			
16	T7W E00 294	ADDRESS BOARD		1	1		A.B			
17	—	TERMINAL COVER		1	1	(BG02J608G01)				
18	T7W A14 716	TERMINAL BLOCK	3P(L,N,⊕)	1	1		TB2			
19	T7W E00 716	TERMINAL BLOCK	3P(M1,M2,S)	1	1		TB5			
20	T7W 512 716	TERMINAL BLOCK	2P(1,2)	1	1		TB15			
21	R01 588 255	FAN MOTOR CAPACITOR	2.0 μ F 440V	1			C1			
	R01 576 255	FAN MOTOR CAPACITOR	3.0 μ F 440V		1		C1			
22	T7W E34 310	INDOOR CONTROLLER BOARD		1	1		I.B			
23	T7W 520 239	FUSE	250V 6.3A	1	1		FUSE			
24	—	CONTROLLER COVER		1	1	(BG02A648G02)				
25	—	CONTROLLER CASE		1	1	(BG25J080H02)				
26	R01 E02 313	POWER BOARD		1	1		P.B			
27	—	MOTOR BAND		1	1	(BG02H065H01)				
28	R01 12G 105	RUBBER MOUNT		2						
	R01 16G 105	RUBBER MOUNT			2					
29	R01 12G 220	FAN MOTOR	D094P40MS	1			MF			
	T7W 571 762	FAN MOTOR	D10A4P70MS		1		MF			
30	—	MOTOR LEG		1		(BG02A534H16)				
	—	MOTOR LEG			1	(RG02A534H17)				
31	—	MOTOR BAND		1	1	(BG02H178H01)				
32	T7W E17 401	LINEAR EXPANSION VALVE		1			LEV			
	T7W E18 401	LINEAR EXPANSION VALVE			1		LEV			
33	R01 13G 115	RIGHT LINE FLOW FAN		1						
	R01 17G 115	RIGHT LINE FLOW FAN			1					
34	—	CENTER SUPPORT		1	1	(BG00R259G08)				
35	R01 12G 103	SLEEVE BEARING		1	1					
36	R01 KV5 102	BEARING MOUNT		1	1					
37	—	BEARING BAND		1	1	(BG02L462H02)				
38	T7W B02 675	FAN GUARD		2						
	T7W B03 675	FAN GUARD			2					
39	—	REMOTE CONTROLLER	PAR-21MAA	1	1		R.B			
④0	R01 05A 304	ADDRESS CABLE		1	1					

ELECTRICAL PARTS
PKFY-P63VFM-E
PKFY-P100VFM-E

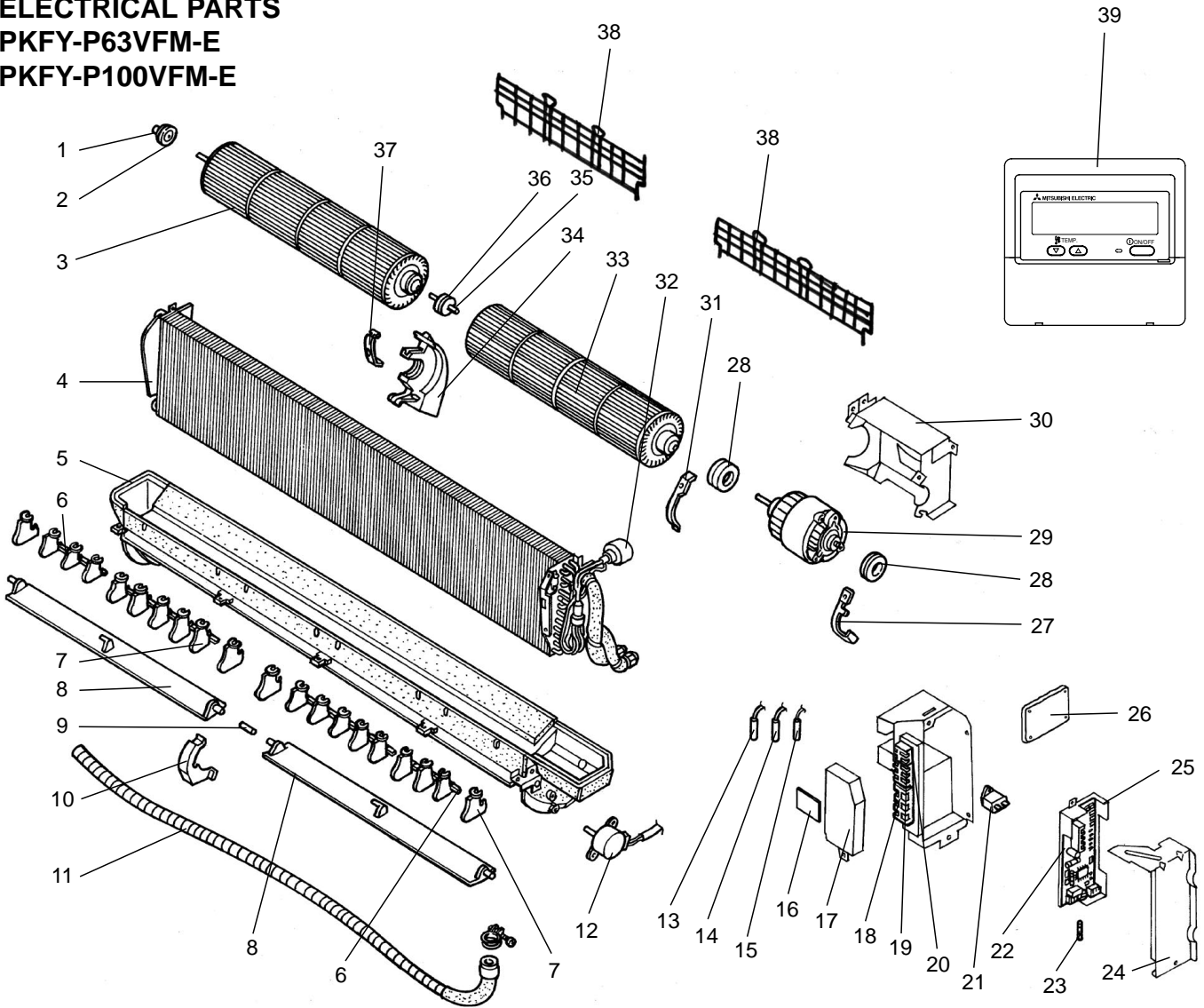

No.	RoHS	Part No.	Part Name	Specification	Q'ty / set		Remarks (Drawing No.)	Wiring Diagram Symbol	Recom- mended Q'ty	Price	
					63	100				Unit	Amount
					PKFY-P-VFM-E						
1	G	R01 Z61 102	BEARING MOUNT		1	1					
2	G	R01 E04 103	SLEEVE BEARING		1	1					
3	G	R01 E23 114	LEFT LINEFLOW FAN		1						
	G	R01 E24 114	LEFT LINEFLOW FAN			1					
4	G	T7W K28 480	HEAT EXCHANGER		1						
	G	T7W K29 480	HEAT EXCHANGER			1					
5	G	T7W E24 529	DRAIN PAN		1						
	G	T7W E25 529	DRAIN PAN			1					
6	G	—	ARM		3	4	(BG25H301H02)				
7	G	—	GUIDE VANE		16	22	(BG25J821H01)				
	G	—	GUIDE VANE (WITH HANDELE)		4	4	(BG25J821H02)				
8	G	R01 18G 002	AUTO VANE		2						
	G	R01 19G 002	AUTO VANE			2					
9	G	R01 13G 063	JOINT SHAFT		1	1					
10	G	R01 14G 621	CENTER COVER		1	1					
11	G	R01 E04 527	DRAIN HOSE		1	1					

Part number that is circled is not shown in the figure.

No.	RoHS	Part No.	Part Name	Specification	Q'ty / set		Remarks (Drawing No.)	Wiring Diagram Symbol	Recom- mended Q'ty	Price	
					PKFY-P•VFM-E					Unit	Amount
					63	100					
12	G	T7W E05 223	VANE MOTOR		1	1		MV			
13	G	R01 H15 202	GAS PIPE THERMISTOR		1	1		TH23			
14	G	R01 H06 202	ROOM TEMPERATURE THERMISTOR		1	1		TH21			
15	G	R01 H05 202	LIQUID PIPE THERMISTOR		1	1		TH22			
16	G	T7W E01 294	ADDRESS BOARD		1	1		A.B			
17	G	—	TERMINAL COVER		1	1	(BG02J608G01)				
18	G	T7W E32 716	TERMINAL BLOCK	3P(L,N,⊕)	1	1		TB2			
19	G	T7W E35 716	TERMINAL BLOCK	3P(M1,M2,S)	1	1		TB5			
20	G	T7W E33 716	TERMINAL BLOCK	2P(1,2)	1	1		TB15			
21	G	R01 E13 255	FAN MOTOR CAPACITOR	2.0μF 440V	1			C1			
	G	R01 E12 255	FAN MOTOR CAPACITOR	3.0μF 440V		1		C1			
22	G	T7W E53 310	INDOOR CONTROLLER BOARD		1	1		I.B			
23	G	R01 E06 239	FUSE	250V 6.3A	1	1		FUSE			
24	G	—	CONTROLLER COVER		1	1	(BG02A648G02)				
25	G	—	CONTROLLER CASE		1	1	(BG25J080H02)				
26	G	R01 E38 313	POWER BOARD		1	1		P.B			
27	G	—	MOTOR BAND		1	1	(BG02H065H01)				
28	G	R01 12G 105	RUBBER MOUNT		2						
	G	R01 16G 105	RUBBER MOUNT			2					
29	G	R01 13G 220	FAN MOTOR	D094P40MS	1			MF			
	G	T7W E24 762	FAN MOTOR	D10A4P70MS		1		MF			
30	G	—	MOTOR LEG		1		(BG02A534H16)				
	G	—	MOTOR LEG			1	(RG02A534H17)				
31	G	—	MOTOR BAND		1	1	(BG02H178H01)				
32	G	T7W E19 401	LINEAR EXPANSION VALVE		1			LEV			
	G	T7W E20 401	LINEAR EXPANSION VALVE			1		LEV			
33	G	R01 E04 115	RIGHT LINE FLOW FAN		1						
	G	R01 E05 115	RIGHT LINE FLOW FAN			1					
34	G	—	CENTER SUPPORT		1	1	(BG00R259G08)				
35	G	R01 E03 103	SLEEVE BEARING		1	1					
36	G	R01 KV5 102	BEARING MOUNT		1	1					
37	G	—	BEARING BAND		1	1	(BG02L462H02)				
38	G	T7W E15 675	FAN GUARD		2						
	G	T7W E16 675	FAN GUARD			2					
39	G	—	REMOTE CONTROLLER	PAR-21MAA	1	1		R.B			
④0	G	R01 A01 304	ADDRESS CABLE		1	1					

STRUCTURAL PARTS
PKFY-P63VFM-E
PKFY-P100VFM-E

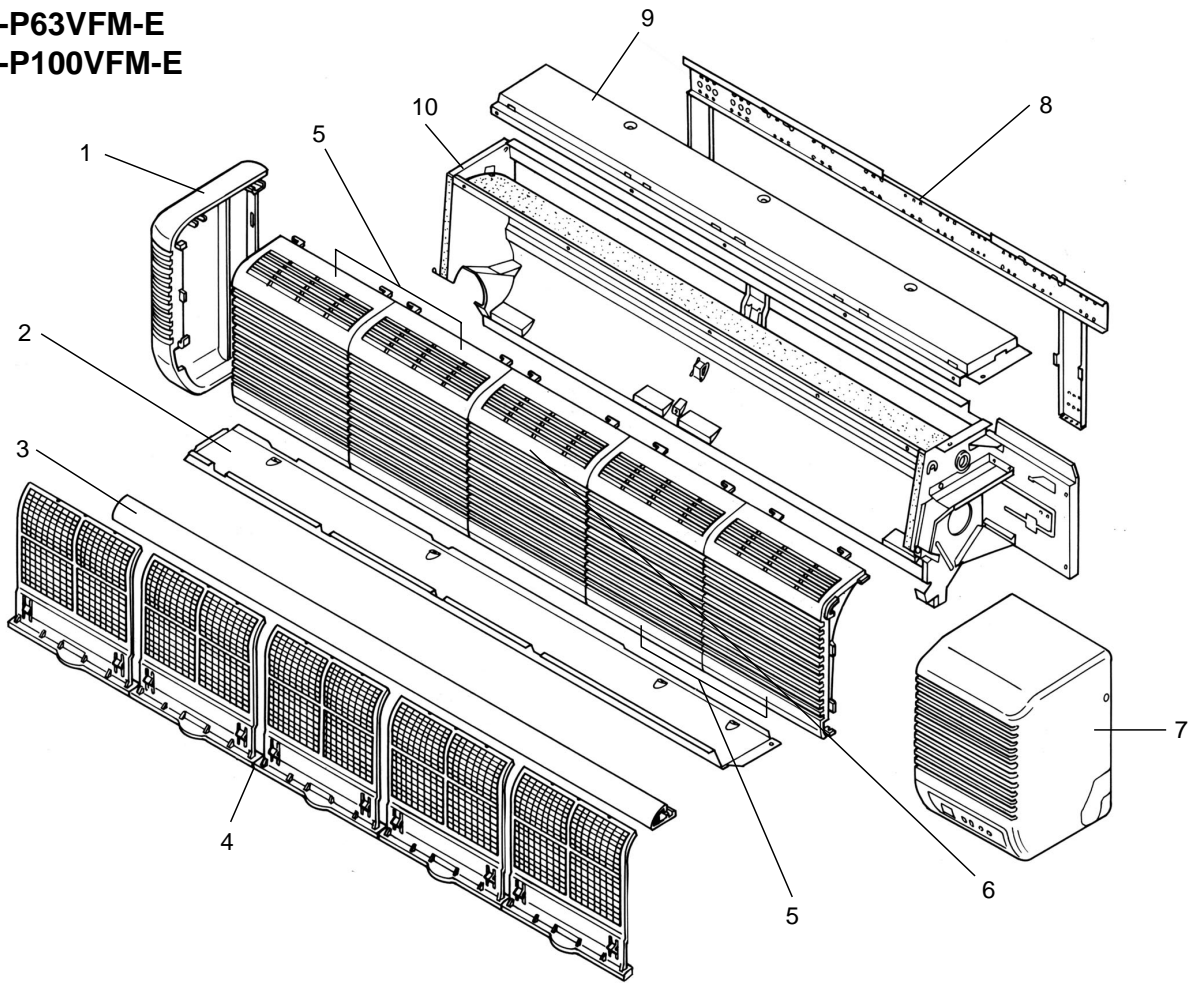

Part number that is circled is not shown in the figure.

No.	RoHS	Part No.	Part Name	Specification	Q'ty / set		Remarks (Drawing No.)	Wiring Diagram Symbol	Recom- mended Q'ty	Price	
					PKFY-P•VFM-E					Unit	Amount
					63	100					
1	G	R01 14G 662	LEFT SIDE PANEL		1	1					
2	G	R01 E02 812	UNDER PLATE		1						
	G	R01 E03 812	UNDER PLATE			1					
3	G	R01 E00 811	NOSE		1						
	G	R01 E01 811	NOSE			1					
4	G	R01 A17 500	AIR FILTER		4	5					
5	G	R01 17G 691	INTAKE GRILLE		2	2					
6	G	R01 18G 692	INTAKE GRILLE			1					
7	G	R01 14G 661	RIGHT SIDE PANEL		1	1					
8	G	R01 E03 808	BACK PLATE		1						
	G	R01 E04 808	BACK PLATE			1					
9	G	R01 E19 641	TOP PLATE		1						
	G	R01 E20 641	TOP PLATE			1					
10	G	—	BOX ASSEMBLY		1		(RG00A734GJ3)				
	G	—	BOX ASSEMBLY			1	(RG00A734GJ4)				
⑪	G	R01 E02 523	DRAIN SOCKET		1	1					

CITY MULTI

 **mitsubishi electric corporation**

HEAD OFFICE : TOKYO BLDG., 2-7-3, MARUNOUCHI, CHIYODA-KU, TOKYO100-8310, JAPAN
