



Air-Conditioners

2006

TECHNICAL & SERVICE MANUAL

Models **PEFY-P20VMS-E, PEFY-P40VMS-E**
PEFY-P25VMS-E, PEFY-P50VMS-E
PEFY-P32VMS-E, PEFY-P63VMS-E

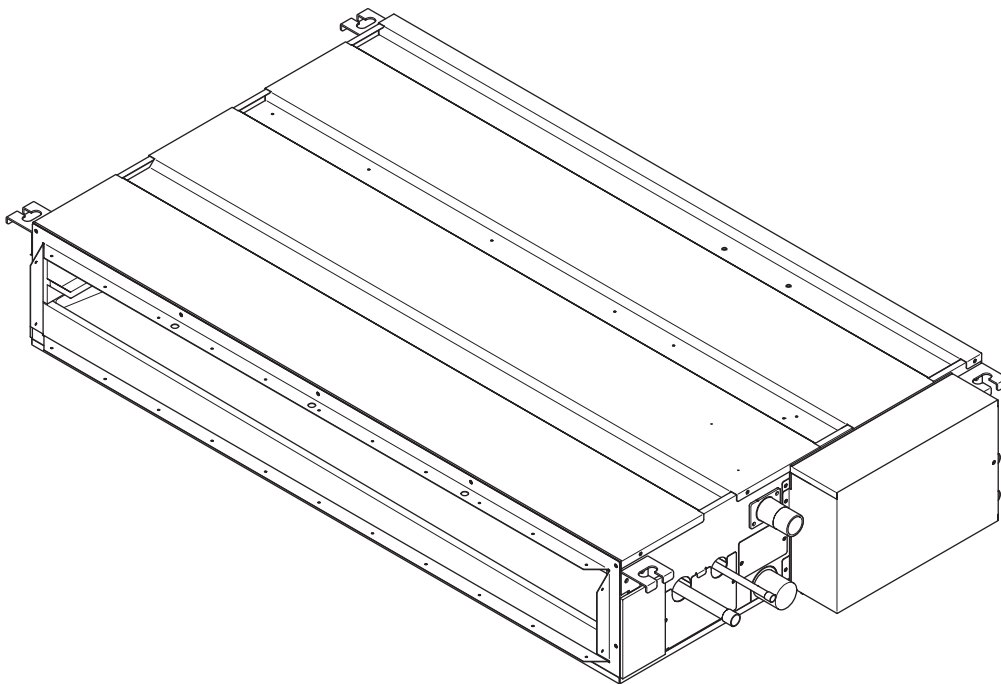

CITY MULTI

For use with R410A, R407C, & R22

Safety Precautions

Read before installation and performing electrical work

- Thoroughly read the following safety precautions prior to installation.
- Observe these safety precautions for your safety.
- This equipment may have adverse effects on the equipment on the same power supply system.
- Contact the local power authority before connecting to the system.

Symbol explanations



WARNING

This symbol indicates that failure to follow the instructions exactly as stated poses the risk of serious injury or death.



CAUTION

This symbol indicates that failure to follow the instructions exactly as stated poses the risk of serious injury or damage to the unit.



Indicates an action that must be avoided.



Indicates important instructions.



Indicates a parts that requires grounding.



Indicates that caution must be taken with rotating parts. (This symbol is on the main unit label.) <Color: Yellow>



Indicates that the parts that are marked with this symbol pose a risk of electric shock. (This symbol is on the main unit label.) <Color: Yellow>



WARNING

Carefully read the labels affixed to the main unit.



WARNING

Ask your dealer or a qualified technician to install the unit.

Improper installation by the user may result in water leakage, electric shock, or fire.

Properly install the unit on a surface that can withstand its weight.

Unit installed on an unstable surface may fall and cause injury.

Only use specified cables. Securely connect each cable so that the terminals do not carry the weight of the cable.

Improperly connected cables may produce heat and start a fire.

Take appropriate safety measures against wind gusts and earthquakes to prevent the unit from toppling over.

Improper installation may cause the unit to topple over and cause injury or damage to the unit.

Only use accessories (i.e., air cleaners, humidifiers, electric heaters) recommended by Mitsubishi Electric.

Do not make any modifications or alterations to the unit. Consult your dealer for repair.

Improper repair may result in water leakage, electric shock, or fire.

Do not touch the heat exchanger fins with bare hands.

The fins are sharp and pose a risk of cuts.

In the event of a refrigerant leak, thoroughly ventilate the room.

If gaseous refrigerant leaks out and comes in contact with an open flame, toxic gases will be generated.

Properly install the unit according to the instructions in the Installation Manual.

Improper installation may result in water leakage, electric shock, or fire.

Have all electrical work performed by an authorized electrician according to the local regulations and the instructions in this manual. Use a dedicated circuit.

Insufficient power supply capacity or improper installation of the unit may result in malfunctions of the unit, electric shock, or fire.

WARNING

Keep electrical parts away from water.

Wet electrical parts pose a risk of electric shock, smoke, or fire.

Securely attach the control box cover.

If the cover is not installed properly, dust or water may infiltrate and pose a risk of electric shock, smoke, or fire.

Only use the type of refrigerant that is indicated on the unit when installing or relocating the unit.

Infiltration of any other types of refrigerant or air into the unit may adversely affect the refrigerant cycle and may cause the pipes to burst or explode.

When installing the unit in a small space, take appropriate precautions to prevent leaked refrigerant from reaching the limiting concentration.

Leaked refrigerant gas will displace oxygen and may cause oxygen starvation. Consult your dealer before installing the unit.

Consult your dealer or a qualified technician when moving or reinstalling the unit.

Improper installation may result in water leakage, electric shock, or fire.

After completing the service work, check for a refrigerant leak.

If leaked refrigerant is exposed to a heat source, such as a fan heater, stove, or electric grill, toxic gases will be generated.

Do not try to defeat the safety features of the unit.

Forced operation of the pressure switch or the temperature switch by defeating the safety features for these devices, or the use of accessories other than the ones that are recommended by Mitsubishi Electric may result in smoke, fire, or explosion.

Consult your dealer for proper disposal method.

Do not use a leak detection additive.

Precautions for handling units for use with R410A

CAUTION

Do not use the existing refrigerant piping.

A large amount of chlorine that may be contained in the residual refrigerant and refrigerator oil in the existing piping may cause the refrigerator oil in the new unit to deteriorate.

Use refrigerant piping materials made of phosphorus deoxidized copper. Keep the inner and outer surfaces of the pipes clean and free of such contaminants as sulfur, oxides, dust, dirt, shaving particles, oil, and moisture.

Contaminants in the refrigerant piping may cause the refrigerator oil to deteriorate.

Store the piping materials indoors, and keep both ends of the pipes sealed until immediately before brazing. (Keep elbows and other joints wrapped in plastic.)

Infiltration of dust, dirt, or water into the refrigerant system may cause the refrigerator oil to deteriorate or cause the compressor to malfunction.

Use a small amount of ester oil, ether oil, or alkyl benzene to coat flares and flanges.

Infiltration of a large amount of mineral oil may cause the refrigerator oil to deteriorate.

Charge the system with refrigerant in the liquid phase.

If gaseous refrigerant is drawn out of the cylinder first, the composition of the remaining refrigerant in the cylinder will change and become unsuitable for use.

Only use R410A.

The use of other types of refrigerant that contain chloride may cause the refrigerator oil to deteriorate.

Use a vacuum pump with a check valve.

If a vacuum pump that is not equipped with a check valve is used, the vacuum pump oil may flow into the refrigerant cycle and cause the refrigerator oil to deteriorate.

Prepare tools for exclusive use with R 410A. Do not use the following tools if they have been used with the conventional refrigerant: gauge manifold, charging hose, gas leak detector, check valve, refrigerant charge base, vacuum gauge, and refrigerant recovery equipment.

If the refrigerant or the refrigerator oil that may be left on these tools are mixed in with R410A, it may cause the refrigerator oil in the new system to deteriorate.

Infiltration of water may cause the refrigerator oil to deteriorate. Leak detectors for conventional refrigerants will not detect an R410A leak because R410A is free of chlorine.

Do not use a charging cylinder.

If a charging cylinder is used, the composition of the refrigerant in the cylinder will change and become unsuitable for use.

Exercise special care when handling tools for use with R410A.

Infiltration of dust, dirt, or water into the refrigerant system may cause the refrigerator oil to deteriorate.

I Features

[1] Features..... 1

II Components and Functions

[1] Components and Functions..... 2

III Specifications

[1] Specifications..... 4
 1.Specifications 4
 2.Electrical component specifications..... 6

IV Outlines and Dimensions

[1] Outlines and Dimensions 7

V Wiring Diagram

[1] Wiring Diagram 8

VI Refrigerant System Diagram

[1] Refrigerant system diagram..... 10

VII Troubleshooting

[1] Troubleshooting 11
 1.Check methods..... 11
 2.DC fan motor (fan motor/indoor control board)..... 15
 3.Address switch setting 16
 4.Voltage test points on the control board 17
 5.Dipswitch setting (Factory setting)..... 18

VIII Disassembly Procedure

[1] Disassembly Procedure 20
 1.Control box 20
 2.Thermistor (Intake air) 21
 3.Drainpan 22
 4.Thermistor (Gas pipe) (Liquid pipe) 23
 5.Fan and fan motor 24
 6.Bearing 25
 7.Heat exchanger 26

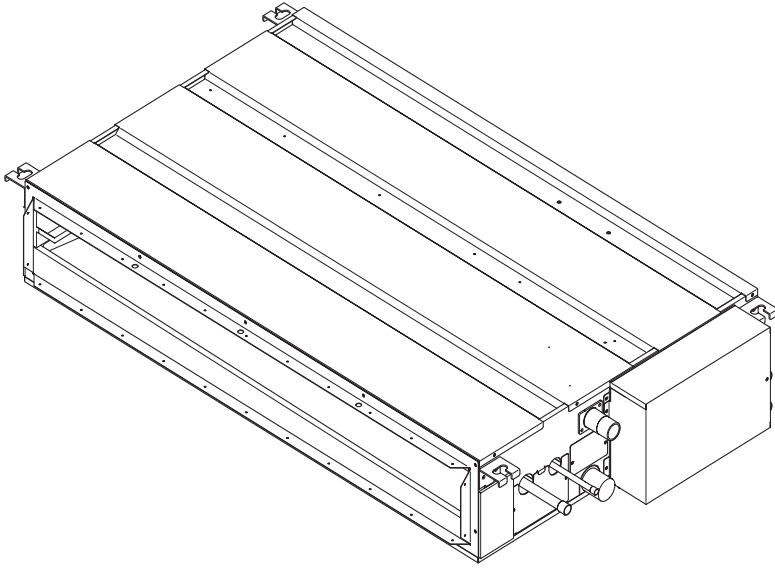
[1] Features

Model	Cooling capacity/Heating capacity
	kW
PEFY-P20VMS-E	2.2/2.5
PEFY-P25VMS-E	2.8/3.2
PEFY-P32VMS-E	3.6/4.0
PEFY-P40VMS-E	4.5/5.0
PEFY-P50VMS-E	5.6/6.3
PEFY-P63VMS-E	7.1/8.0

[1] Components and Functions

1. Indoor (Main) Unit

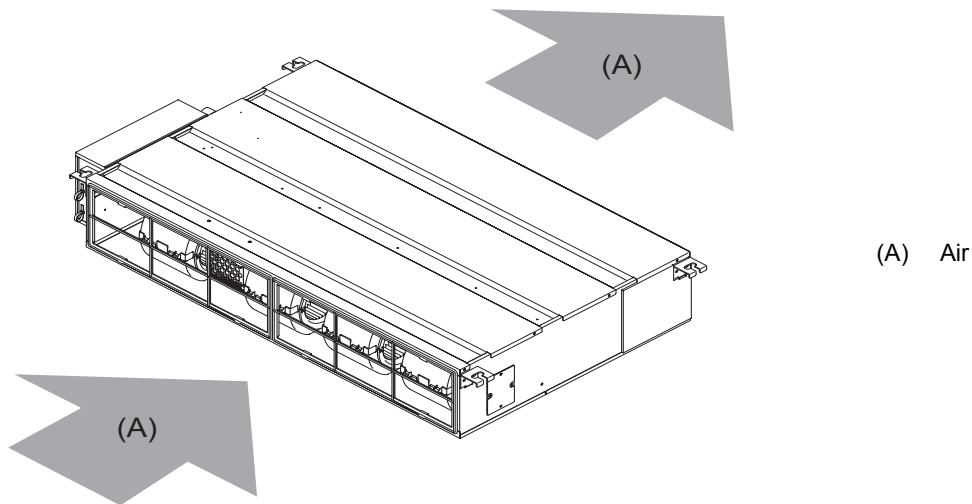

(A) Air

2. Remote Controller

[PAR-21MAA]

Once the operation mode is selected, the unit will remain in the selected mode until changed.

(1) Remote Controller Buttons

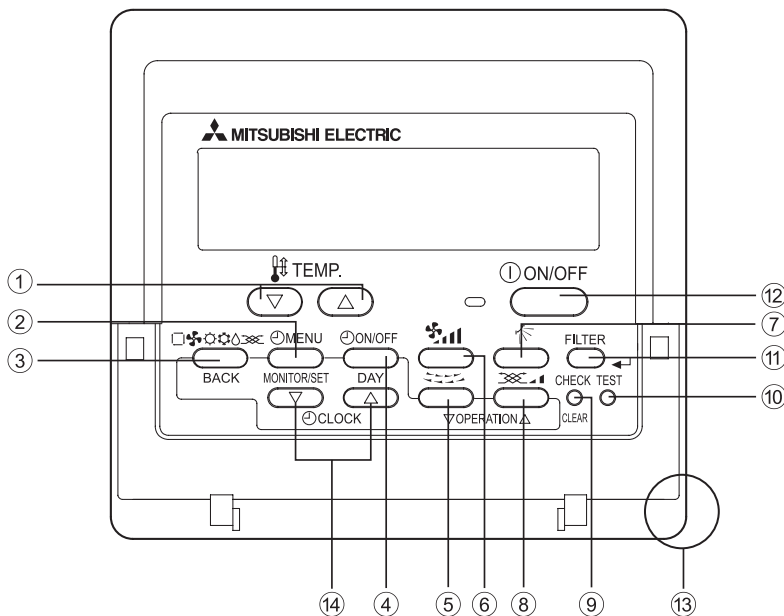



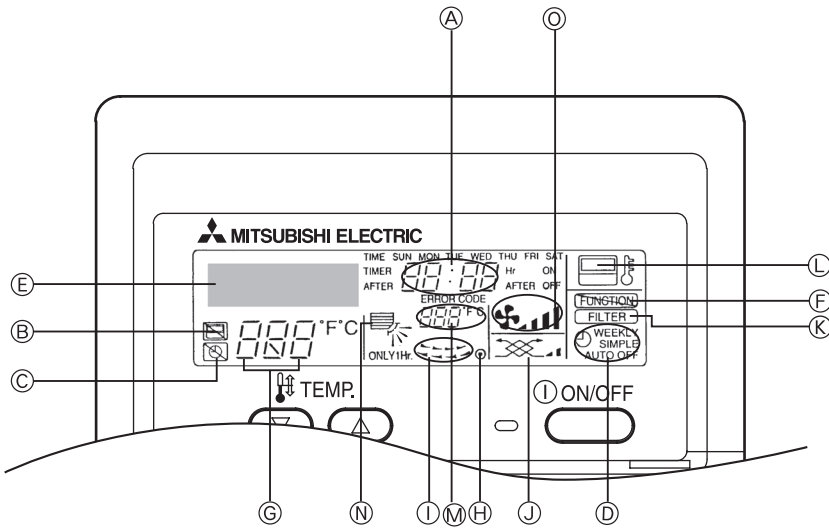

- | | |
|----------------------------|---|
| 1 [Set Temperature] Button | 7 [Vane Control] Button |
| 2 [Timer Menu] Button | 8 [Ventilation] Button |
| [Monitor/Set] Button | [Operation] Button |
| 3 [Mode] Button | 9 [Check/Clear] Button |
| [Back] Button | 10 [Test Run] Button |
| 4 [Timer On/Off] Button | 11 [Filter] Button |
| [Set Day] Button | [] Button |
| 5 [Louver] Button | 12 [ON/OFF] Button |
| [Operation] Button | 13 Position of built-in room thermistor |
| 6 [Fan Speed] Button | 14 [Set Time] Button |

- Keep the remote controller out of direct sunlight to ensure accurate measurement of room temperature.
- The thermistor at the lower right-hand section of the remote controller must be free from obstructions to ensure accurate measurement of room temperature.

(2) Remote Controller Display



- | | | | |
|---|---|---|------------------|
| A | Current time/Timer time | I | Louver swing |
| B | Centralized control indicator | J | Ventilation |
| C | Timer OFF indicator | K | Filter sign |
| D | Timer mode | L | Sensor position |
| E | Operation mode display:  COOL,  DRY,  AUTO,  FAN,  HEAT | M | Room temperature |
| F | Function Lock indicator | N | Vane setting |
| G | Preset temperature | O | Fan speed |
| H | Power indicator | | |

[1] Specifications**1. Specifications**

Model			PEFY-P20VMS-E	PEFY-P25VMS-E	PEFY-P32VMS-E
Power supply	Voltage	V	220-240		
	Frequency	Hz	50/60		
Cooling capacity		kW	2.2	2.8	3.6
Heating capacity		kW	2.5	3.2	4.0
Power consumption	Cooling	kW	0.08/0.08	0.08/0.08	0.09/0.09
	Heating	kW	0.06/0.06	0.06/0.06	0.07/0.07
Current consumption	Cooling	A	0.39/0.39	0.39/0.39	0.44/0.44
	Heating	A	0.28/0.28	0.28/0.28	0.33/0.33
External finish (Munsel No.)			Galvanized		
Dimensions	Height	mm	200		
	Width	mm	900		
	Depth	mm	700		
Net weight		kg	23	23	23
Heat exchanger			Cross fin (Aluminium fin and copper tube)		
Fan	Type		Sirocco fan x 3		
	Airflow rate (Low-Mid-High)	m ³ /min	6.0-7.0-8.0	6.0-7.0-8.0	7.5-8.5-10.0
	External static pressure	Pa	5/15/35/50	5/15/35/50	5/15/35/50
Motor	Type		DC brushless motor		
	Output	kW	0.096		
Air filter			PP Honeycomb fabric (washable)		
Refrigerant pipe dimensions	Gas (Brazed connection)	mm [in.]	ø12.7 [ø1/2]		
	Liquid (Brazed connection)	mm [in.]	ø6.35 [ø1/4]		
Drain pipe dimensions		mm [in.]	O.D. 32 [1-9/32]		
Operating noise (Low-Mid-High)	5Pa	dB (A)	21-23-26	21-23-26	23-26-29
	15Pa		22-25-27	22-25-27	25-28-30
	35Pa		25-27-30	25-27-30	27-29-33
	50Pa		26-29-32	26-29-32	28-31-35

Note: Maximum capacity of the unit under the following conditions

<Cooling> Indoor temperature: 27°CDB/19°CWB (81°FDB/66°F WB) Outdoor temperature: 35°CDB (95°FDB)

<Heating> Indoor temperature: 20°CDB (68°FDB) Outdoor temperature: 7°CDB/6°CWB (45°FDB/43°F WB)

[III Specifications]

Model			PEFY-P40VMS-E	PEFY-P50VMS-E	PEFY-P63VMS-E
Power supply	Voltage	V	220-240		
	Frequency	Hz	50/60		
Cooling capacity		kW	4.5	5.6	7.1
Heating capacity		kW	5.0	6.3	8.0
Power consumption	Cooling	kW	0.11/0.11	0.13/0.13	0.14/0.14
	Heating	kW	0.09/0.09	0.11/0.11	0.12/0.12
Current consumption	Cooling	A	0.53/0.53	0.63/0.63	0.68/0.68
	Heating	A	0.42/0.42	0.52/0.52	0.57/0.57
External finish (Munsel No.)			Galvanized		
Dimensions	Height	mm	200		
	Width	mm	900	1100	
	Depth	mm	700	700	
Net weight		kg	24	24	28
Heat exchanger			Cross fin (Aluminium fin and copper tube)		
Fan	Type		Sirocco fan x 3		Sirocco fan x 4
	Airflow rate (Low-Mid-High)	m ³ /min	8.0-9.5-11.0	9.5-11.0-13.0	12.0-14.0-16.5
	External static pressure	Pa	5/15/35/50	5/15/35/50	5/15/35/50
Motor	Type		DC brushless motor		
	Output	kW	0.096		
Air filter			PP Honeycomb fabric (washable)		
Refrigerant pipe dimensions	Gas (Brazed connection)	mm [in.]	ø12.7 [ø1/2]	R410A: ø12.7 [ø1/2] R22: ø15.88 [ø5/8]	ø15.88 [ø5/8]
	Liquid (Brazed connection)	mm [in.]	ø6.35 [ø1/4]	R410A: ø6.35 [ø1/4] R22: ø9.52 [ø3/8]	ø9.52 [ø3/8]
Drain pipe dimensions		mm [in.]	O.D. 32 [1-9/32]		
Operating noise (Low-Mid-High)	5Pa	dB (A)	26-28-30	29-31-34	29-32-35
	15Pa		28-30-33	30-32-35	30-33-36
	30Pa		30-32-35	31-34-37	31-35-39
	50Pa		31-33-36	32-34-38	32-36-40

Note: Maximum capacity of the unit under the following conditions

<Cooling> Indoor temperature: 27°CDB/19°CWB (81°FDB/66°F WB) Outdoor temperature: 35°CDB (95°FDB)

<Heating> Indoor temperature: 20°CDB (68°FDB) Outdoor temperature: 7°CDB/6°CWB (45°FDB/43°F WB)

2. Electrical component specifications

Component	Sym- bol	PEFY- P20VMS-E	PEFY- P25VMS-E	PEFY- P32VMS-E	PEFY- P40VMS-E	PEFY- P50VMS-E	PEFY- P63VMS-E
Room temperature ther- mistor	TH21	Resistance 0°C/15k Ω, 10°C/9.6kΩ, 20°C/6.3kΩ, 25°C/5.4kΩ, 30°C/4.3kΩ, 40°C/3.0kΩ					
Liquid pipe thermistor	TH22	Resistance 0°C/15k Ω, 10°C/9.6kΩ, 20°C/6.3kΩ, 25°C/5.4kΩ, 30°C/4.3kΩ, 40°C/3.0kΩ					
Gas pipe thermistor	TH23	Resistance 0°C/15k Ω, 10°C/9.6kΩ, 20°C/6.3kΩ, 25°C/5.4kΩ, 30°C/4.3kΩ, 40°C/3.0kΩ					
Fuse	FUSE	250V 6.3A					
Fan motor		4-pole, Output 96W SIC-70CW-D896-1					
Linear expansion valve	LEV	12VDC Stepping motor drive port diameter ø3.2 (0~2000 pulse)					
Power supply terminal block	TB2	(L, N, ⊕) 330V 30A					
Transmission terminal block	TB5 TB15	(1, 2), (M1, M2, S) 250V 20A					
Drain float switch	DS	Open/short detection Initial contact resistance 500 mΩ or less					

[1] Outlines and Dimensions

1. PEFY-P20,25,32,40,50,63VMS-E

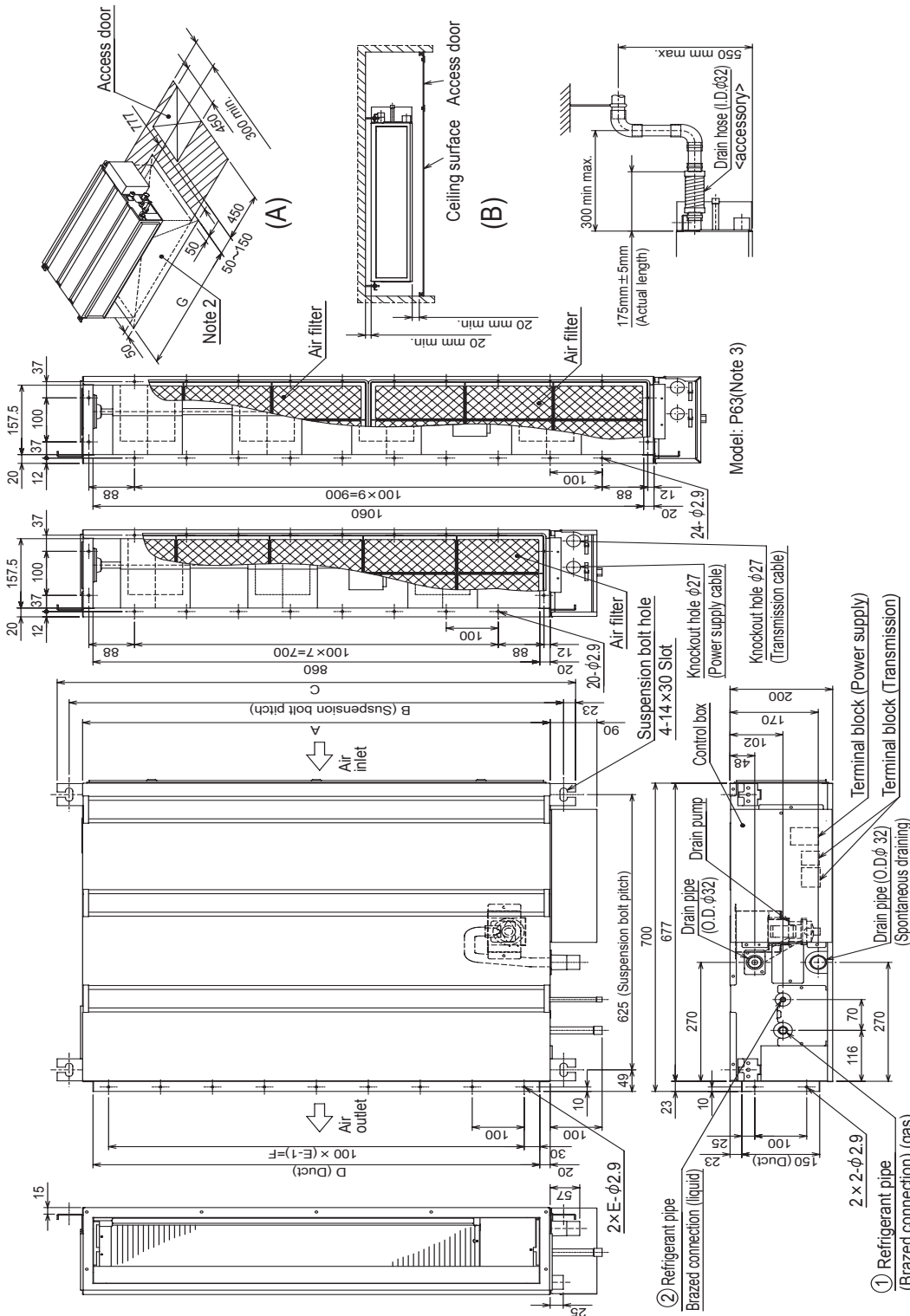

*1 : R410A outdoor unit
*2 : R407C,R22 outdoor unit

Model	A	B	C	D	E	F	G	① Gas pipe	② Liquid pipe
PEFY-P20, 25, 32, 40VMS-E	900	952	998	860	9	800	1000	φ12.7	φ 6.35
PEFY-P50VMS-E	1100	1152	1198	1060	11	1000	1200	*2 φ15.88	*2 φ 9.52
								φ15.88	φ 9.52

- (A) Space required for service and maintenance.
- (B) Provide an access door for maintenance at the bottom.

- Note
- 1 Use M10 suspension bolts. (not supplied)
 - 2 Provide an access door for maintenance at the bottom.
 - 3 The dimensions in the table are those of the PEFY-P20~50VMS-E models, which have 3 fans. The PEFY-P63VMS-E model has 4 fans.
 - 4 To connect an intake duct, uninstall the air filter on the unit, and install a locally procured air filter on the intake duct on the intake side.

[1] Wiring Diagram

1. PEFY-P20,25,32,40,50,63VMS-E

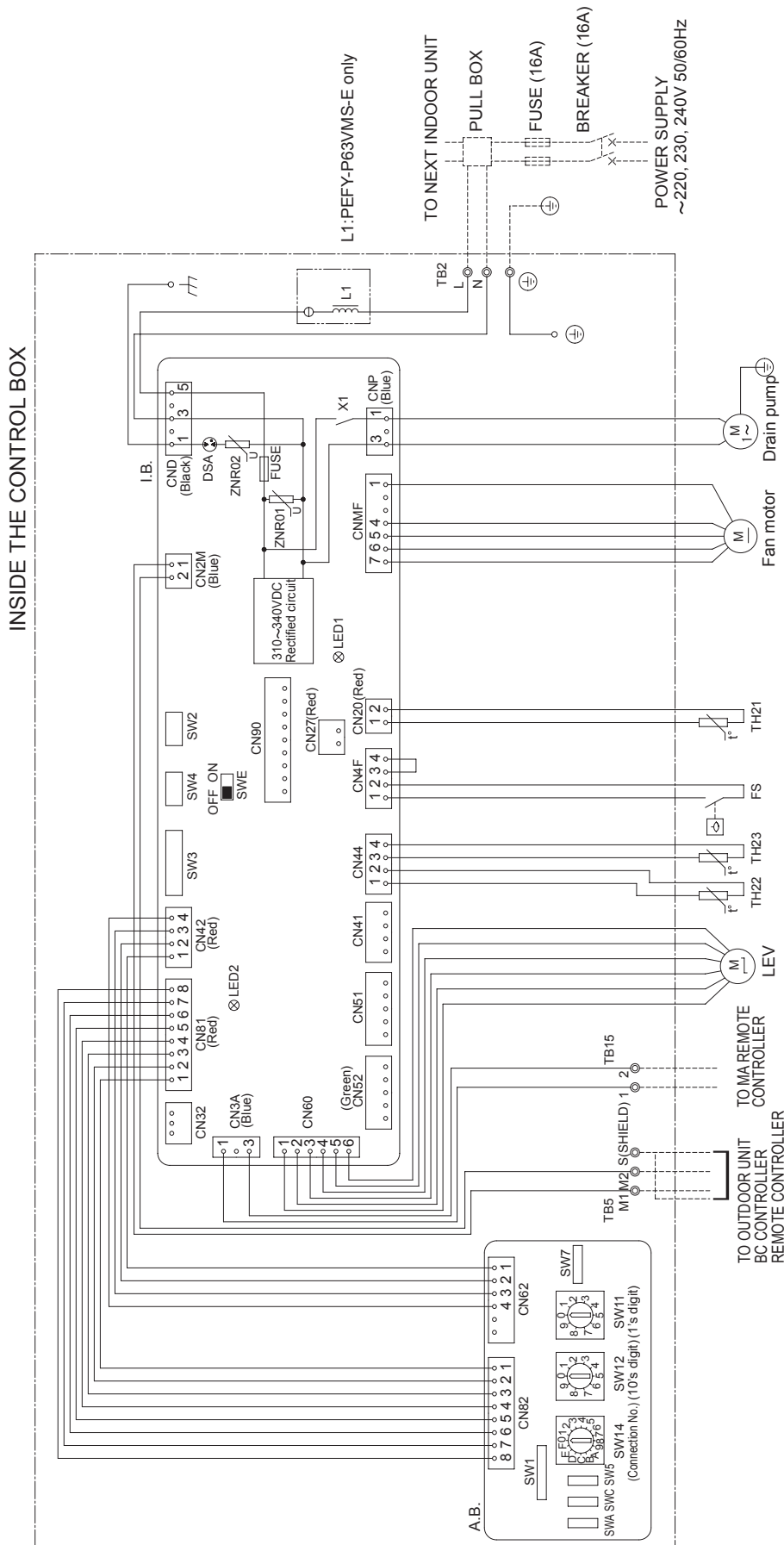

Table.1 SYMBOL EXPLANATION

SYM-BOL	NAME	SYM-BOL	NAME	SYM-BOL	NAME
I.B.	Indoor control board	CN32	Connector (Remote switch)	SW4 (I.B.)	Switch (function setting)
A.B.	Address board	CN41	Connector (HA terminal-A)	SWE (I.B.)	Connector (emergency operation)
TB2	Power supply terminal block	CN51	Connector (Centralized control)	SW1 (A.B.)	Switch (function setting)
TB5	Transmission terminal block	CN52	Connector (Remote display)	SW5 (A.B.)	Switch (function setting)
TB15	Transmission terminal block	CN90	Connector (Wireless)	SW7 (A.B.)	Switch (function setting)
FUSE	Fuse 250ACV 6.3A	FS	Float switch	SW11 (A.B.)	Switch (For setting the 1's digit in the address)
ZNR01, 02	Varistor	TH21	Thermistor (inlet air)	SW12 (A.B.)	Switch (For setting the 10's digit in the address)
DSA	Arrester	TH22	Thermistor (liquid pipe)	SW14 (A.B.)	Switch (connection No.setting)
X1	Aux. relay	TH23	Thermistor (gas pipe)	SWA (A.B.)	Switch (static pressure setting)
L1	AC reactor (Power factor improvement)	SW2 (I.B.)	Switch (capacity code setting)	SWC (A.B.)	Switch (static pressure setting)
CN27	Connector (Damper)	SW3 (I.B.)	Switch (function setting)		

Note 1 Wiring to TB2, TB5, and TB15 indicated by the double-dashed lines is on-site work.

2 ⊙ terminal bed, ⊖ connector.

[1] Refrigerant system diagram

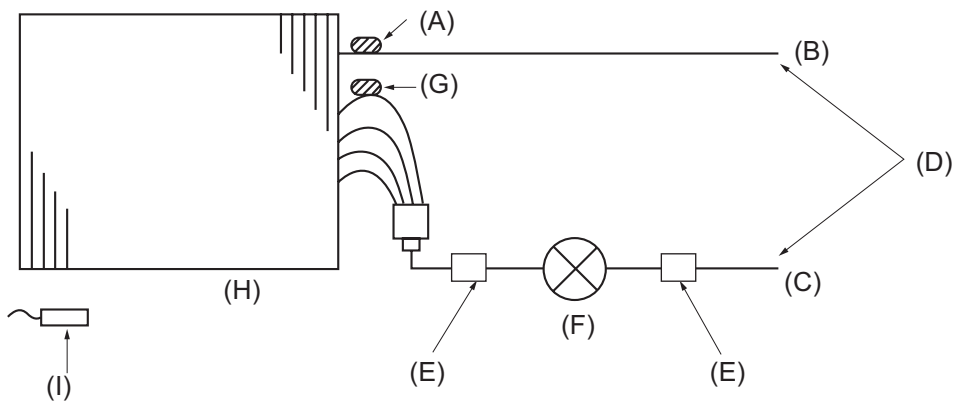

- (A) Gas pipe thermistor TH23
- (B) Gas pipe
- (C) Liquid pipe
- (D) Brazed connections
- (E) Strainer (#100 mesh)
- (F) Linear expansion valve
- (G) Liquid pipe thermistor TH22
- (H) Heat exchanger
- (I) Room temperature thermistor TH21

Capacity	PEFY-P20, 25, 32, 40VMS-E	PEFY-P50VMS-E	PEFY-P63VMS-E
Gas pipe	ø12.7 [1/2]	R410A: ø12.7 [1/2] R22: ø15.88 [5/8]	ø15.88 [5/8]
Liquid pipe	ø6.35 [1/4]	R410A: ø6.35 [1/4] R22: ø9.52 [3/8]	ø9.52 [3/8]

[1] Troubleshooting

1. Check methods

1. Component and check points

(1) Thermistor

- Room temperature thermistor (TH21)
- Liquid pipe thermistor (TH22)
- Gas pipe thermistor (TH23)

Disconnect the connector and measure the resistance between terminals with a tester.
(Ambient temperature 10°C - 30°C)

Normal	Abnormal
4.3kΩ - 9.6kΩ	Open or short

(Refer to the thermistor characteristic graph below.)

1) Thermistor characteristic graph

Low-temperature thermistor

- Room temperature thermistor (TH21)
- Liquid pipe thermistor (TH22)
- Gas pipe thermistor (TH23)
- Drain sensor (DS)

- Thermistor $R_0 = 15\text{ k}\Omega \pm 3\%$
- Multiplier of B = $3480\text{ k}\Omega \pm 2\%$

$$R_t = 15 \exp \left\{ 3480 \left(\frac{1}{273+t} - \frac{1}{273} \right) \right\}$$

- 0°C 15kΩ
- 10°C 9.6kΩ
- 20°C 6.3kΩ
- 25°C 5.2kΩ
- 30°C 4.3kΩ
- 40°C 3.0kΩ

(A) Temperature (°C)

(B) Resistance (kΩ)

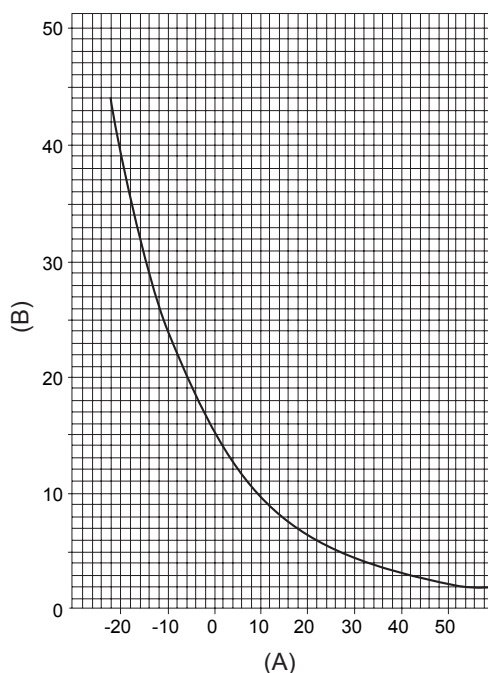

(2) Fan motor (CNMF)

Refer to the page on "DC fan motor (fan motor/indoor control board)."

(3) Linear expansion valve

Disconnect the connector, and measure the resistance between terminals with a tester.
Refer to the next page for details.

	Normal				Abnormal
	1-5 White-Red	2-6 Yellow-Brown	3-5 Orange-Red	4-6 Blue-Brown	
	200 kΩ ± 10%				Open or short

- (A) Brown (D) Orange
- (B) Red (E) Yellow
- (C) Blue (F) White

1) Summary of linear expansion valve (LEV) operation

- The LEV is operated by a stepping motor, which operates by receiving a pulse signal from the indoor control board.
- The LEV position changes in response to the pulse signal.

Indoor control board and LEV connection

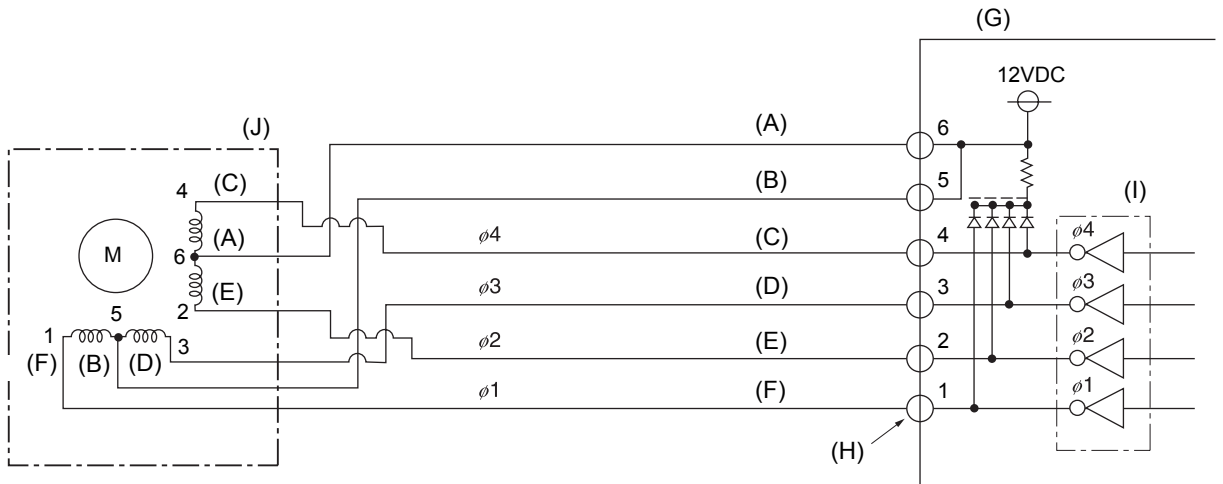

- | | |
|------------|----------------------------|
| (A) Brown | (F) White |
| (B) Red | (G) Control board |
| (C) Blue | (H) Connection (CN60) |
| (D) Orange | (I) Drive circuit |
| (E) Yellow | (J) Linear expansion valve |

Pulse signal output and valve operation

Phase number	Output pulse			
	1	2	3	4
ø1	ON	OFF	OFF	ON
ø2	ON	ON	OFF	OFF
ø3	OFF	ON	ON	OFF
ø4	OFF	OFF	ON	ON

The output pulse changes in the following order:

When the valve closes 1 -> 2 -> 3 -> 4 -> 1

When the valve opens 4 -> 3 -> 2 -> 1 -> 4

- When the valve position remains the same, all output signals will be OFF.
- If any output signal is missing or if the signal remains ON, the motor vibrates and makes clicking noise.

2) LEV operation

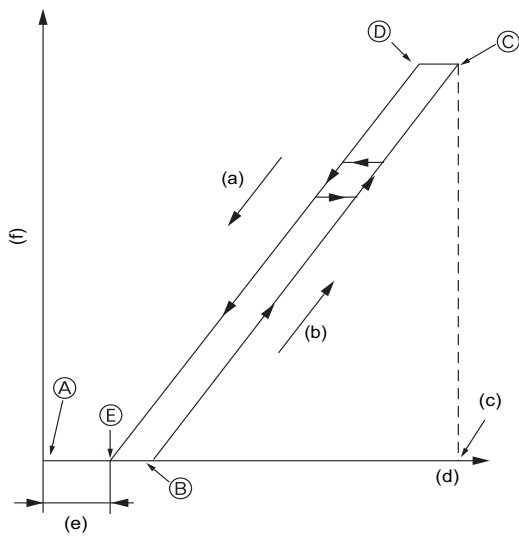

- (a) Close
- (b) Open
- (c) Fully open valve (2000 pulses)
- (d) No. of pulses
- (e) Extra tightening (80 - 100 pulse)
- (f) Valve opening degree

- When the power is turned on, a pulse signal of 2200 pulses is output (valve closure signal), to bring the valve to position A.
- When the valve is operating normally, it is free of vibration noise. If the valve locks or when it goes from point E to A in the figure, it makes louder noise than would be heard when there is an open phase.
- Check for abnormal sound/vibration by placing the metal tip of a screwdriver against the valve and the handle side against your ear.

3) Troubleshooting

Symptom	Checking Criteria	Remedy
Circuit failure on the microcomputer	<p>Disconnect the connectors on the control board, and connect LEDs to test the circuit as shown below.</p> <p>Pulse signals are output for 10 seconds when the main power is turned on. If there are LEDs that do not light up at all or remain lit after the pulses are turned off, there is a problem with the driving circuit.</p>	Replace the indoor control board if driving circuit failure is detected.
Locked LEV	The motor will idle and make small clicking noise if it is run while the LEV is locked. If this clicking noise is heard both when the valve is fully closed and while it is being opened, it indicates a problem.	Replace the LEV.
Disconnected or shorted LEV motor coils	Measure the resistance between the coils with a tester (red-white, red-orange, brown-yellow, brown-blue). The normal range of resistance is $150 \Omega \pm 10\%$	Replace the LEV.

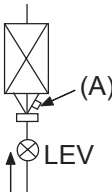
Symptom	Checking Criteria	Remedy
Valve closure failure (leaky valve)	<p>To check the LEV on the indoor unit, check the indoor unit liquid pipe temperature that appears on the operation monitor on the outdoor unit's multi control board while operating the indoor unit in question in the FAN mode and the other indoor units in the cooling mode.</p> <p>(A) Termistor (TH21)</p>  <p>Normally, the LEV is fully closed while the unit is in the FAN mode. If the valve is leaky, liquid pipe thermistor reading will be lower than normal. If it is significantly lower than the inlet temperature on the remote controller, valve closure failure is suspected. If the amount of leakage is insignificant, replacement of LEV is unnecessary unless it is causing a problem.</p>	Replace the LEV if the amount of leakage is great.
Misconnections of connectors or contact failure	<p>Perform a visual check for disconnected connectors.</p> <p>Perform a visual check of lead wire color.</p>	Disconnect the connectors on the control board and perform a continuity test.

(4) Drain-up mechanism

Measure the resistance between the terminals with a tester.
(coil temperature 20°C)

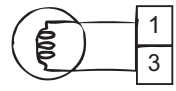
	Normal	Abnormal
	340 Ω	Open or short

(5) Drain float switch (CN4F)

Disconnect the connector, and measure the resistance between terminals with a tester.

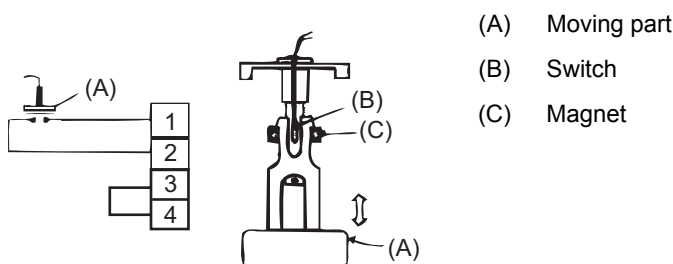

Position of the moving part	Normal	Abnormal
Up	Short	(any position but short)
Down	Open	(any position but open)

2. DC fan motor (fan motor/indoor control board)

1. CAUTION

- A high voltage is applied to the connector for connection to the fan motor (CNMF).
- Do not unplug the connector CNMF with the unit energized to avoid damage to the indoor control board and fan motor.

2. Troubleshooting

- Symptom: Indoor unit fan does not run.

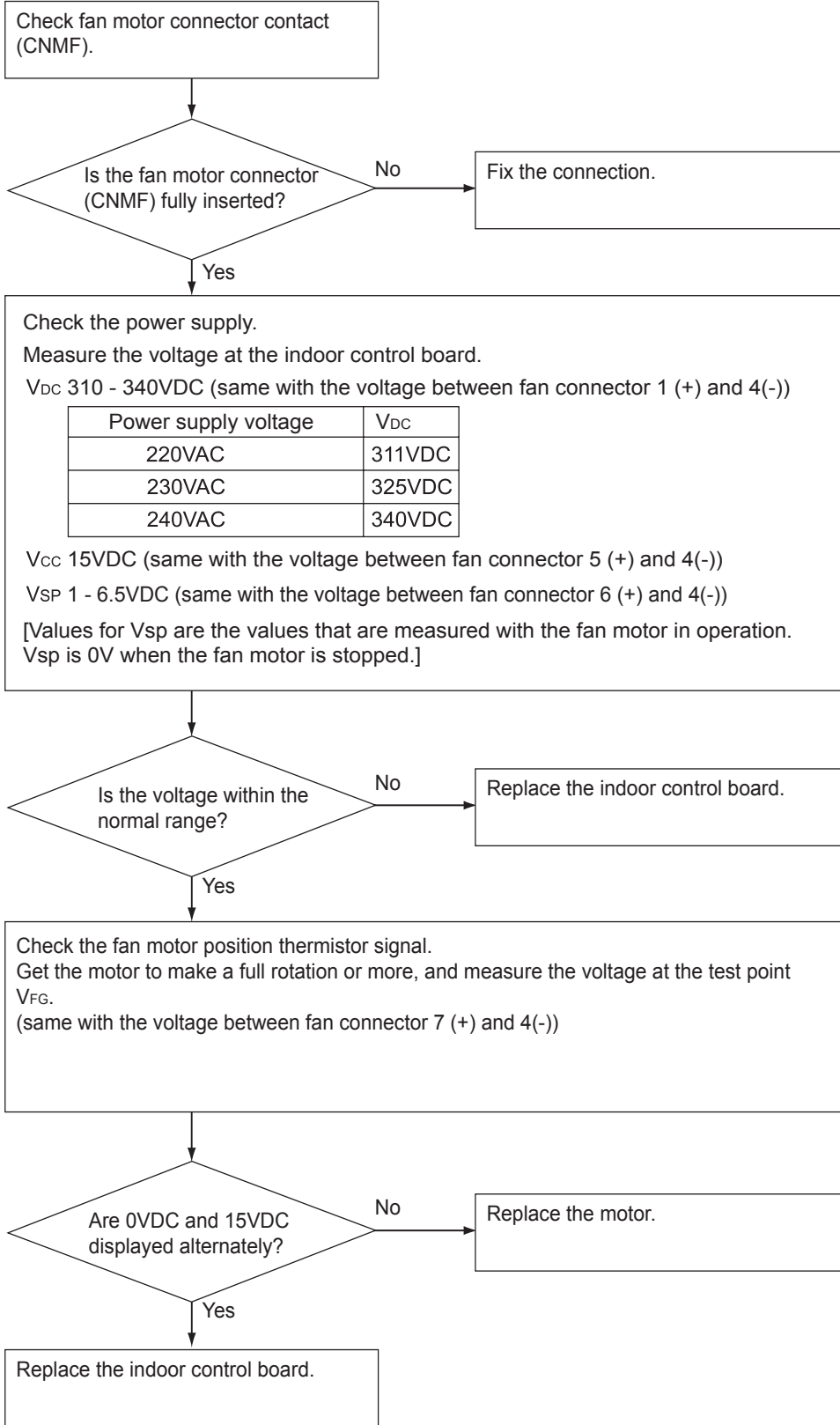

3. Address switch setting

Make sure that power to the unit is turned off.

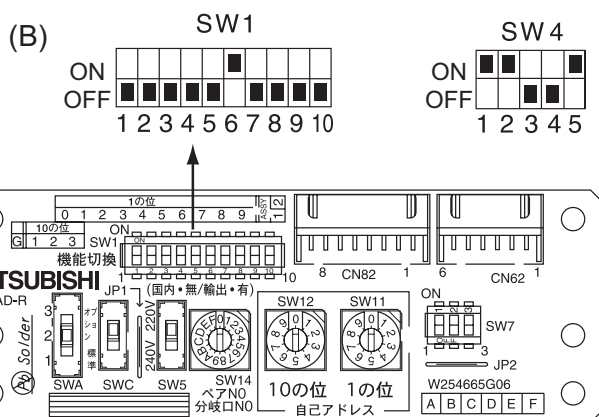
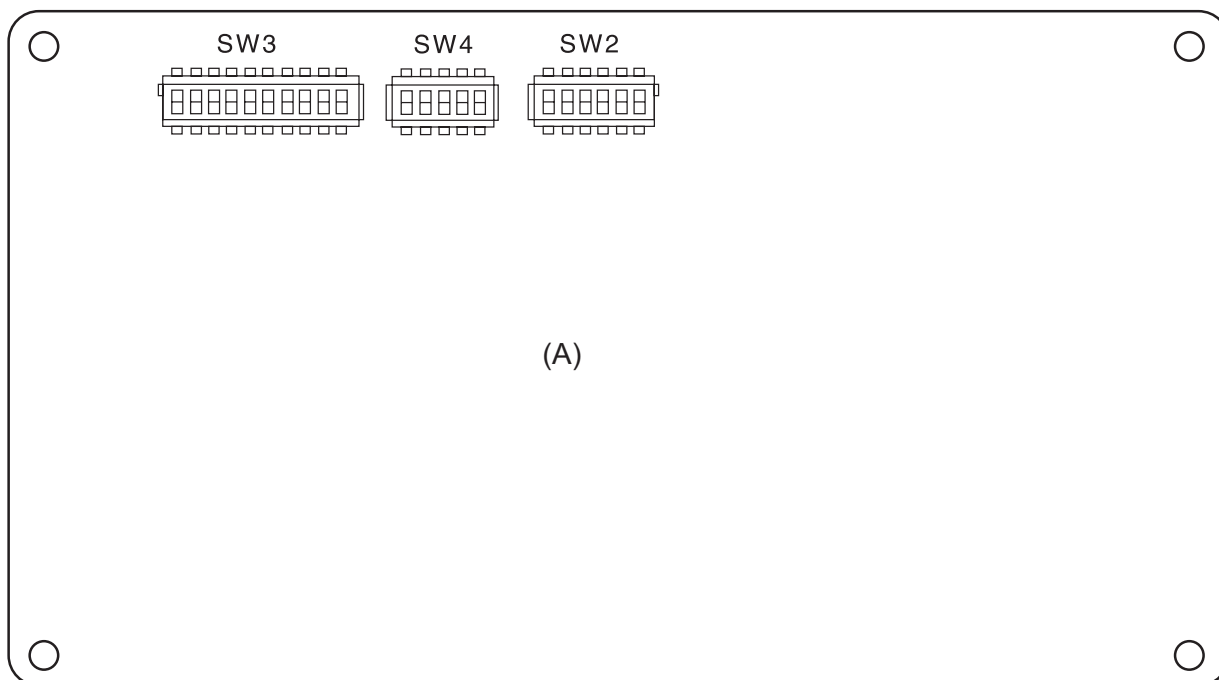

(A) Indoor unit control board

(B) Factory setting (all models)

- When using an ME remote controller, set the address with the rotary switches (SW11, SW12).
 •Address setting is not required when the unit remote controller is used.
On-site address setting is required for the indoor units to run.
- Address settings vary in different systems.
 Refer to the section on address setting in the outdoor unit installation manual.
- Address is set with a combination of SW12 (10's digit) and SW11 (1's digit).
 To set the address to "3," set SW12 to "0" and SW11 to "3."
 To set the address to "25," set SW 12 to "2" and SW 11 to "5."

4. Voltage test points on the control board

1. PEFY-P20, 25, 32, 40, 50, 63VMS-E

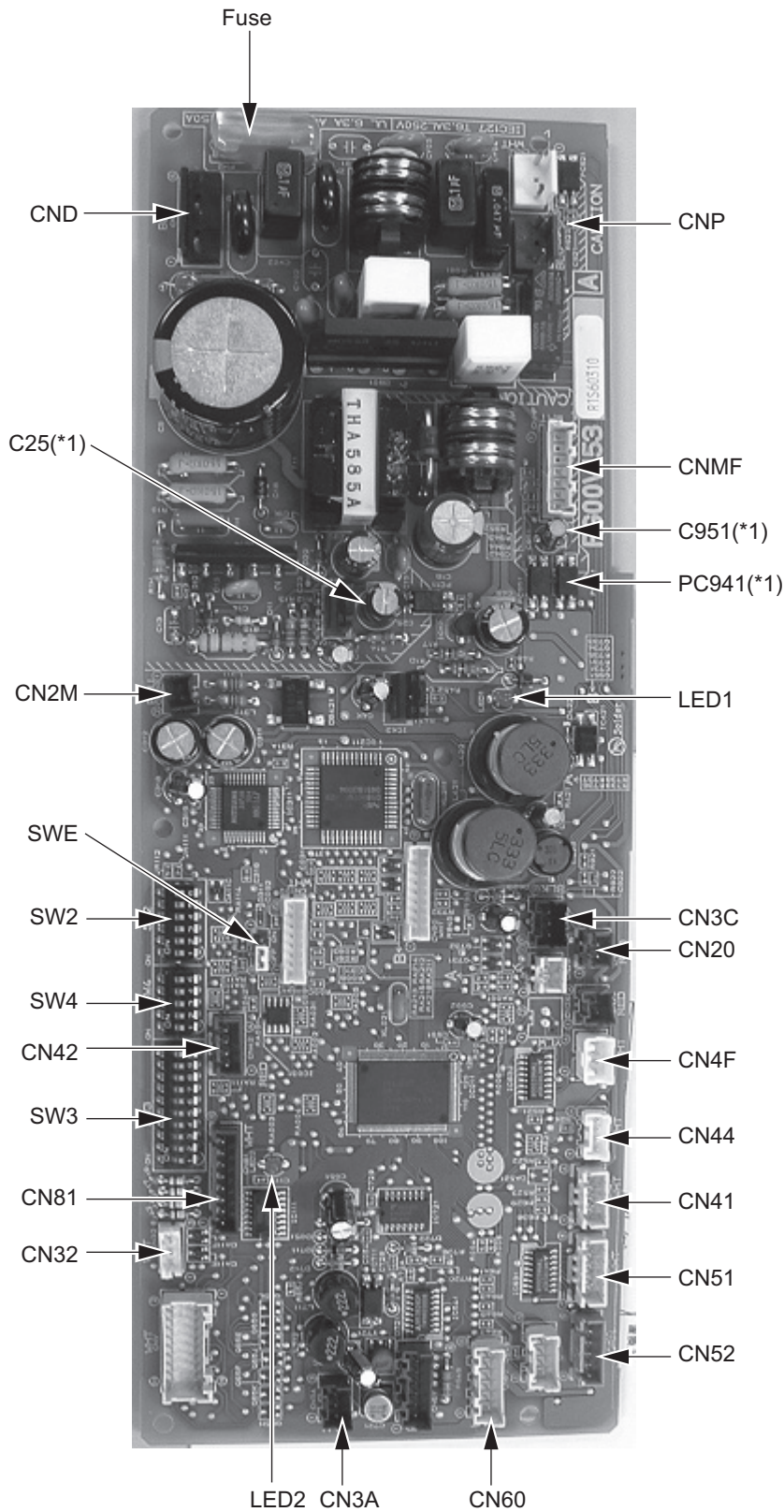

- CND Power supply voltage (220 - 240VAC)
 - CN2M For M-NET transmission cable connection (24 - 30VDC)
 - SWE Emergency operation
 - SW2 Capacity setting
 - SW4 Function setting
 - CN42 For address board connection
 - SW3 Function setting
 - CN81 For address board connection
 - CN32 Remote start/stop adapter
 - CN3A For MA remote controller cable connection (10 - 13 VDC (Between 1 and 3.))
 - CN52 Remote display
 - CN51 Centralized control
 - CN41 JAMA standard HA terminal A
 - CN44 Thermistor (liquid/gas temperature)
 - CN4F Float thermistor
 - CN20 Thermistor (Inlet temperature)
 - CN3C Indoor-outdoor transmission (0 - 24VDC)
 - CNMF Fan motor output
 1 - 4: 310 - 340 VDC
 5 - 4: 15 VDC
 6 - 4: 0 - 6.5 VDC
 7 - 4: Stop 0 or 15 VDC
 Run 7.5 VDC
 (0 - 15 pulse)
 - CNP Drain-up mechanism output (200VAC)
- (*1)
- V_{FG} Voltage on the (-) side of PC941 and C25 (Same with the voltage between 7 (+) and 4 (-) of CNMF)
 - V_{CC} Voltage between the C25 pins 15 VDC (Same with the voltage between 5 (+) and 4 (-) of CNMF)
 - V_{sp} Voltage between the C951 pins
 0VDC (with the fan stopped)
 1 - 6.5VDC (with the fan in operation)
 (Same with the voltage between 6 (+) and 4 (-) of CNMF)

5. Dipswitch setting (Factory setting)

1. Function setting

(1) SW1

Switch position	Function	Switch setting	
		ON	OFF
1	Active Thermistor (Intake air thermistor)	Built-in thermistor on the remote controller	Indoor unit
2	Filter clogging detection	Available	Unavailable
3	Filter life	2500 hr	100 hr
4	Outdoor air intake	Enabled	Disabled
5	Remote display	Thermo-ON signal	Fan output
6	Humidifier operation	During heating mode	During heating operation
7	Fan speed	Low	Very low
8	Fan speed at heating Thermo-OFF	Preset fan speed	Follows the setting of SW1-7
9	Auto restart after power failure	Enabled	Disabled
10	Power start/stop	Enabled	Disabled

1) Address board

Factory setting

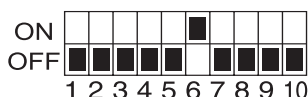

(2) SW3

Switch position	Function	Switch setting	
		ON	OFF
1	Unit type	Cooling only	Heat pump
2	-	-	-
3	-	-	-
4	-	-	-
5	-	-	-
6	-	-	-
7	-	-	-
8	Heating 4-deg up	Disabled	Enabled

1) Indoor control board

Dipswitch settings must be made while the unit is stopped.

Factory setting



2. Capacity code setting

(1) SW2

1) Indoor control board

Dipswitch settings must be made while the unit is stopped.

Factory setting

The switches are set to correspond to the unit capacity.

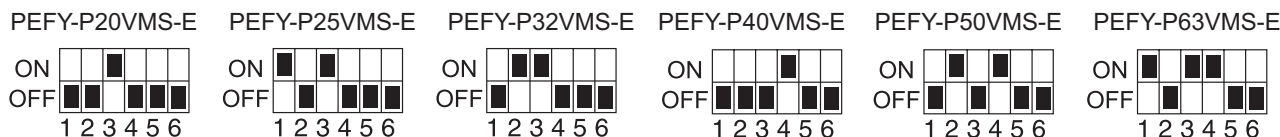

3. Model setting

(1) SW4

1) Indoor control board

Dipswitch settings must be made while the unit is stopped.

Factory setting

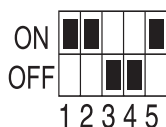

Note:

Changes made to the dipswitches SW1, SW2, and SW3 will become effective when the unit comes to a stop (remote controller off). There is no need to power cycle the unit.

4. External static pressure

(1) SWA, SWC

1) Address board

All models

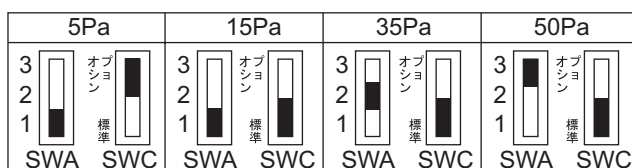

Factory setting

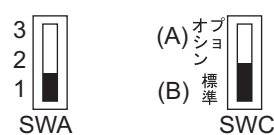

- (A) Option
- (B) Standard

Note:

Changes that are made to the dipswitches SWA and SWC immediately become effective regardless of the unit's operation status (RUN/STOP) or the remote controller status (ON/OFF).

5. 1's and 10's digits

(1) SW11, SW12 (Rotary switch)

The use of a network remote controller (PAR-F27MEA) requires address setting.

1) Address board

Address settings must be made while the unit is stopped.

Factory setting

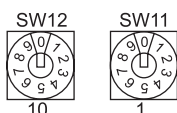

6. Connection No. setting

(1) SW14 (Rotary switch)

This switch is used when the unit connected to an R2 series of outdoor unit.

1) Address board

Factory setting



Note:

Changes to the dipswitches SW11, SW12, SW14, and SW15 must be made while the unit is stopped and the remote controller is OFF.

[1] Disassembly Procedure

1. Control box

Exercise caution when removing heavy parts.

1. Removing the control box cover
 - (1) Remove the two fixing screws on the cover (A) to remove it.

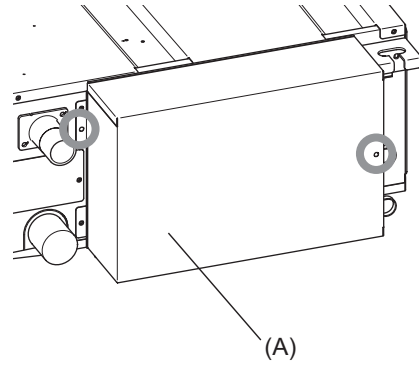

Fig.1

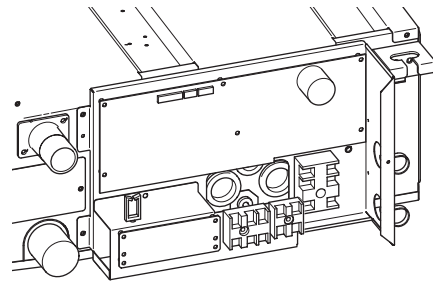

Fig.2

2. Thermistor (Intake air)

Exercise caution when removing heavy parts.

1. Remove the control box cover according to the procedure in section [1].
2. Remove the thermistor.
 - (1) Remove the two fixing screws on the metal base (B) to remove it.

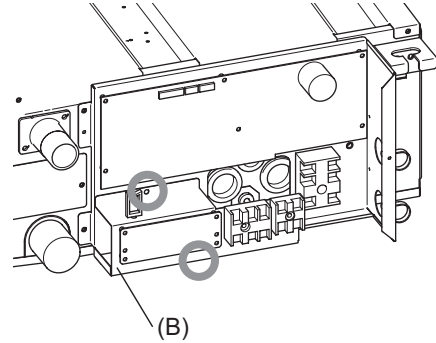

Fig.3

- (2) Pull out the thermistor holder (C) and thermistor (D) on the control box.

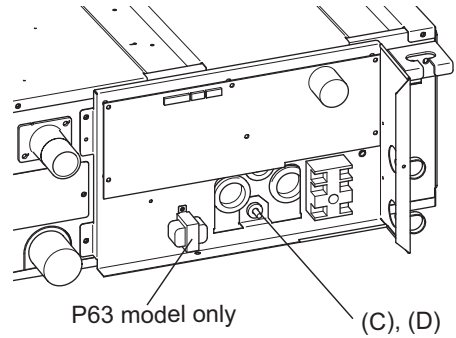

Fig.4

3. Drainpan

Exercise caution when removing heavy parts.

1. Removing the cover
 - (1) Remove the fixing screws on the cover (E) to remove it.

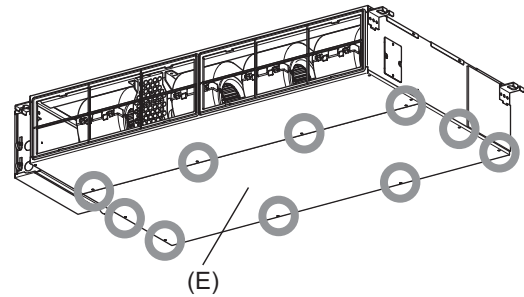

Fig.5

2. Removing the drainpan
 - (1) Pull out the drain pan in the direction of the arrow 1.

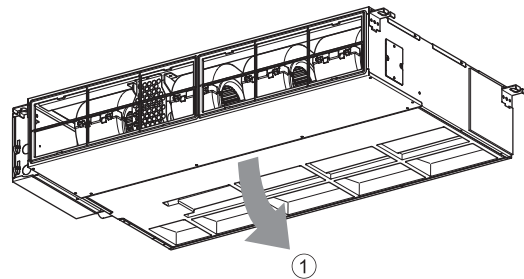

Fig.6

Note

- Drain the water out of the drain pan before removing it.
- To avoid dew condensation, use insulated screws in the places marked with circles in Figure 7.

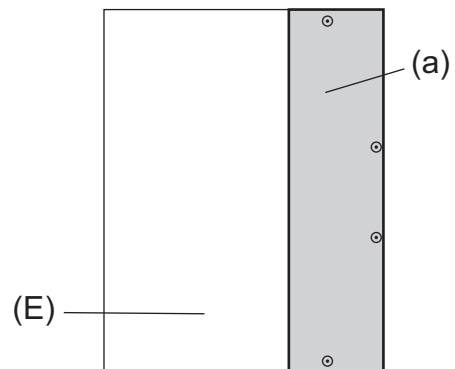

Fig.7

(a) Insulation material

4. Thermistor (Gas pipe) (Liquid pipe)

Exercise caution when removing heavy parts.

1. Remove the drain pan according to the procedure in section [1].
2. Removing the Heat exchanger cover
 - (1) Remove the four fixing screws on the heat exchanger cover (F) to remove it.

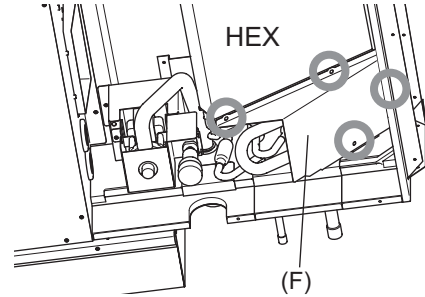

Fig.8

3. Removing the thermistor
 - (1) Remove the thermistor (G) from the thermistor holder (H) on the copper tube.

Thermistor size
Liquid pipe: $\varnothing 8\text{mm}$
Gas pipe: $\varnothing 6\text{mm}$

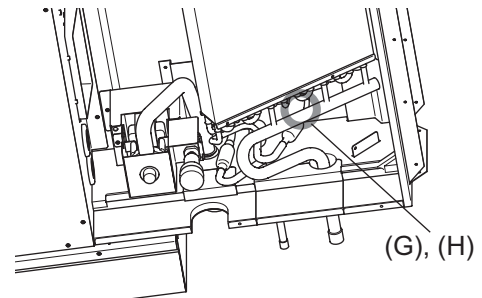

Fig.9

5. Fan and fan motor

Exercise caution when removing heavy parts.

1. Removing the filter and the bottom plate
 - (1) Push down the tab on the filter, and pull out the filter in the direction of the arrow 1.

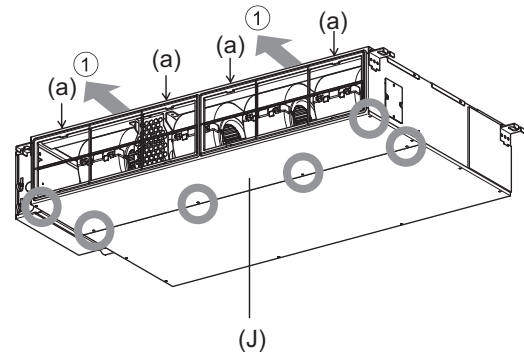

Fig.10

(a) Tab

2. Removing the punching metal
 - (1) Remove the two fixing screws on the punching metal (K) to remove it.
3. Removing the fan casing (bottom half)
 - (1) Squeeze the tabs on the fan casing to remove it in the direction of arrow 2.

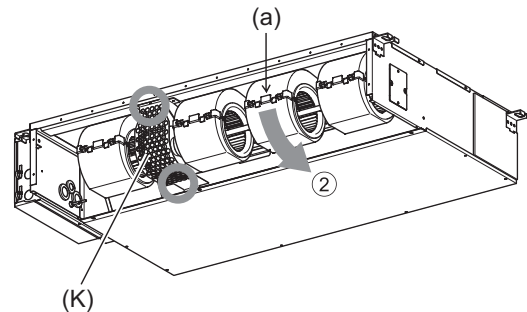

Fig.11

4. Removing the motor cable
 - (1) Remove the motor cable through the rubber bush.
5. Removing the fan motor and the Sirocco fan
 - (1) Remove the two motor fixing screws to remove the motor and the Sirocco fan in the direction of arrow 3.

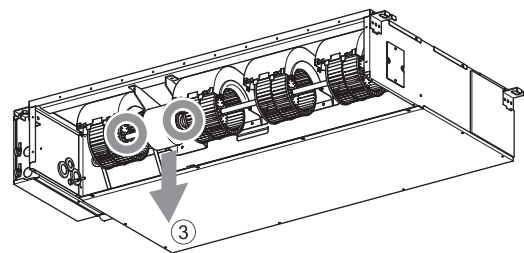

Fig.12

- (2) Remove the four fan case fixing screws to take the top half of the fan casing off.

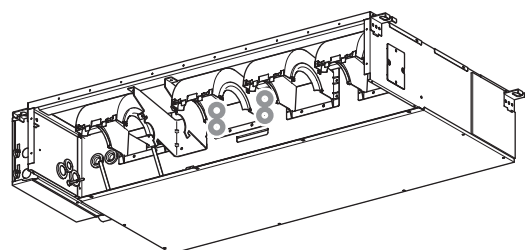

Fig.13

6. Bearing

Exercise caution when removing heavy parts.

1. Removing the bearing
 - (1) Remove the two fixing screws on the bearing cover (M) to remove it.

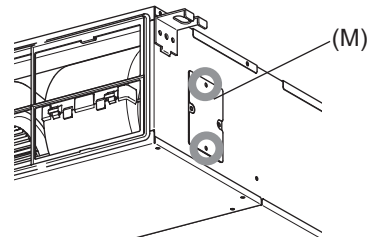

Fig.14

- (2) Remove the two bearing retainer screws to remove the bearing.

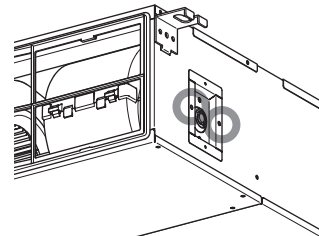

Fig.15

7. Heat exchanger

Exercise caution when removing heavy parts.

1. Remove the drain pan according to the procedure in section [1].
2. Remove the heat exchanger cover according to the procedure in section [4] 2.
3. Removing the cover
 - (1) Remove the two fixing screws on the cover (T) to remove it.

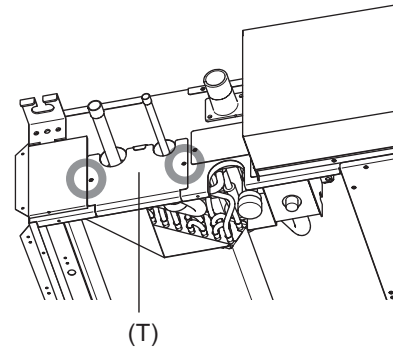

Fig.16

(T) Pipe support plate

4. Removing the Heat exchanger
 - (1) Remove the fixing screws on the heat exchanger (S) to remove it.

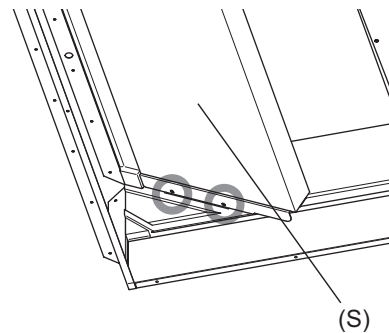

Fig.17

