

Air-Conditioners For Building Application INDOOR UNIT

PFFY-P·VKM-E (2)

For use with the R410A, R407C & R22 Uso del refrigerante R410A, R407C e R22
Bei Verwendung von R410A, R407C & R22 Για χρήση με τα R410A, R407C και R22
A utiliser avec le R410A, R407C et le R22 Para utilização com o R410A, R407C e o R22
Bij gebruik van R410A, R407C & R22 R410A, R407C ve R22 ile beraber kullanmak için
Para utilizar con el R410A, R407C y el R22 Для использования с моделями R410A, R407C и R22

INSTALLATION MANUAL

For safe and correct use, read this manual and the outdoor unit installation manual thoroughly before installing the air-conditioner unit.

FOR INSTALLER

INSTALLATIONSHANDBUCH

Aus Sicherheitsgründen und zur richtigen Anwendung vor Installation der Klimaanlage die vorliegende Bedienungsanleitung und das Installationshandbuch gründlich durchlesen.

FÜR INSTALLATEURE

MANUEL D'INSTALLATION

Avant d'installer le climatiseur, lire attentivement ce manuel, ainsi que le manuel d'installation de l'appareil extérieur pour une utilisation sûre et correcte.

POUR L'INSTALLATEUR

INSTALLATIEHANDLEIDING

Lees deze handleiding en de installatiehandleiding van het buitenapparaat zorgvuldig door voordat u met het installeren van de airconditioner begint.

VOOR DE INSTALLATEUR

MANUAL DE INSTALACIÓN

Para un uso seguro y correcto, lea detalladamente este manual de instalación antes de montar la unidad de aire acondicionado.

PARA EL INSTALADOR

MANUALE DI INSTALLAZIONE

Per un uso sicuro e corretto, prima di installare il condizionatore d'aria leggere attentamente il presente manuale ed il manuale d'installazione dell'unità esterna.

PER L'INSTALLATORE

ΕΓΧΕΙΡΙΔΙΟ ΟΔΗΓΙΩΝ ΕΓΚΑΤΑΣΤΑΣΗΣ

Για σωστή και ασφαλή χρήση, διαβάστε προσεκτικά αυτό το εγχειρίδιο, καθώς και το εγχειρίδιο εγκατάστασης της εξωτερικής μονάδας, πριν από την εγκατάσταση της μονάδας κλιματιστικού.

ΓΙΑ ΑΥΤΟΝ ΠΟΥ ΚΑΝΕΙ ΤΗΝ ΕΓΚΑΤΑΣΤΑΣΗ

MANUAL DE INSTALAÇÃO

Para uma utilização segura e correcta, leia atentamente este manual e o manual de instalação da unidade exterior antes de instalar o aparelho de ar condicionado.

PARA O INSTALADOR

MONTAJ ELKİTABI

Emniyetli ve doğru kullanım için, klima cihazını monte etmeden önce bu kılavuzu ve dış ünite montaj kılavuzunu tamamiyle okuyun.

MONTÖR İÇİN

РУКОВОДСТВО ПО УСТАНОВКЕ

Для обеспечения безопасной и надлежащей эксплуатации внимательно прочтите данное руководство и руководство по установке наружного прибора перед установкой кондиционера.

ДЛЯ УСТАНОВИТЕЛЯ**English (GB)****Deutsch (D)****Français (F)****Nederlands (NL)****Español (E)****Italiano (I)****Ελληνικά (GR)****Português (P)****Türkçe (TR)****Русский (RU)**

Contents

1. Safety precautions.....	2	6. Embedding the indoor unit in a wall.....	6
2. Installation location.....	2	7. Electrical work.....	7
3. Installing the indoor unit.....	3	8. Test run.....	8
4. Refrigerant pipe.....	4	9. Air outlet selection.....	9
5. Drainage piping work.....	5		

Note:
 The phrase “Wired remote controller” in this installation manual refers only to the PAR-21MAA.
 If you need any information for the other remote controller, please refer to either the installation manual or initial setting manual which are included in these boxes.

1. Safety precautions

▶ Before installing the unit, make sure you read all the “Safety precautions”.
 ▶ Please report to your supply authority or obtain their consent before connecting this equipment to the power supply system.

Warning:
 Describes precautions that must be observed to prevent danger of injury or death to the user.

Caution:
 Describes precautions that must be observed to prevent damage to the unit.

After installation work has been completed, explain the “Safety Precautions,” use, and maintenance of the unit to the customer according to the information in the Operation Manual and perform the test run to ensure normal operation. Both the Installation Manual and Operation Manual must be given to the user for keeping. These manuals must be passed on to subsequent users.

- Warning:**
- Ask the dealer or an authorized technician to install the air conditioner.
 - Install the unit at a place that can withstand its weight.
 - Use only specified cables for wiring. The wiring connections must be made securely with no tension applied on the terminal connections. Also, never splice the cables for wiring (unless otherwise indicated in this document).
 - Failure to observe these instructions may result in overheating or a fire.
 - Use only accessories authorized by Mitsubishi Electric and ask the dealer or an authorized technician to install them.
 - Do not touch the heat exchanger fins.
 - Install the air conditioner according to this Installation Manual.

- Caution:**
- Do not use the existing refrigerant piping, when use R410A or R407C refrigerant.
 - Use ester oil, either oil or alkylbenzene (small amount) as the refrigerator oil to coat flares and flange connections, when use R410A or R407C refrigerant.
 - Do not use the air conditioner where food, pets, plants, precision instruments, or artwork are kept.
 - Do not use the air conditioner in special environments.
 - Ground the unit.

2. Installation location

(mm)

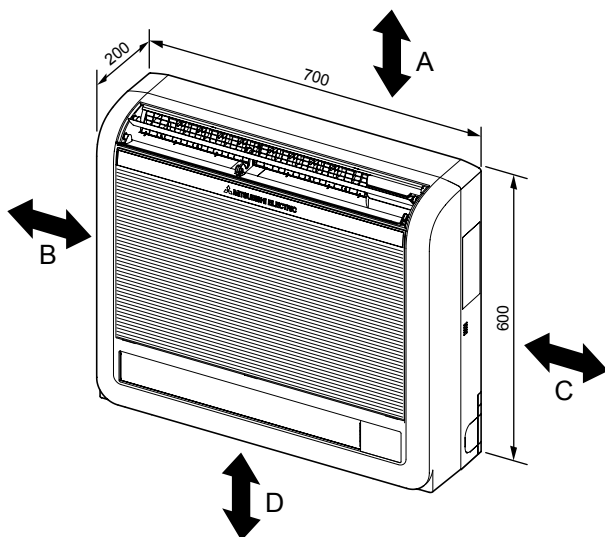

Fig. 2-1

- ⊘ : Indicates an action that must be avoided.
- ⚠ : Indicates that important instructions must be followed.
- ⚡ : Indicates a part which must be grounded.
- ⚠ : Indicates that caution should be taken with rotating parts.
- ⚡ : Indicates that the main switch must be turned off before servicing.
- ⚡ : Beware of electric shock.
- ⚠ : Beware of hot surface.
- ⚡ ELV : At servicing, please shut down the power supply for both the Indoor and Outdoor Unit.

Warning:
 Carefully read the labels affixed to the main unit.

- Have all electric work done by a licensed electrician according to local regulations.
- If the air conditioner is installed in a small room, measures must be taken to prevent the refrigerant concentration from exceeding the safety limit even if the refrigerant should leak.
- The cut face punched parts may cause injury by cut, etc. The installers are requested to wear protective equipment such as gloves, etc.
- When installing or relocating, or servicing the outdoor unit, use only the specified refrigerant (R410A) to charge the refrigerant lines. Do not mix it with any other refrigerant and do not allow air to remain in the lines. If air is mixed with the refrigerant, then it can be the cause of abnormal high pressure in the refrigerant line, and may result in an explosion and other hazards.
- The use of any refrigerant other than that specified for the system will cause mechanical failure or system malfunction or unit breakdown. In the worst case, this could lead to a serious impediment to securing product safety.

- Install an leak circuit breaker, as required.
- Use power line cables of sufficient current carrying capacity and rating.
- Use only a circuit breaker and fuse of the specified capacity.
- Do not touch the switches with wet fingers.
- Do not touch the refrigerant pipes during and immediately after operation.
- Do not operate the air conditioner with the panels and guards removed.
- Do not turn off the power immediately after stopping operation.

The indoor unit should be supplied with the following accessories.

PART NUMBER	ACCESSORY	QUANTITY
①	Drain hose	1
②	Pipe cover	1
③	Band	2
④	Indoor unit mounting bracket	1
⑤	Fixing screw for ④ 4 × 25 mm	5
⑥	Wood screw for the indoor unit fixation	4
⑦	Washer of ⑥	4
⑧	Felt tape (Used for left or left-rear piping)	1
⑨	MA Remote controller cable	1

2.1. Outline dimensions (Indoor unit) (Fig. 2-1)

The unit must be securely installed on a structure that can sustain its weight.

Models	A	B	C	D
P20/25/32/40	100 mm or more	100 mm or more	100 mm or more	150 mm or below from the floor

Warning:
 Mount the indoor unit on a wall structure strong enough to withstand the weight of the unit.

3. Installing the indoor unit

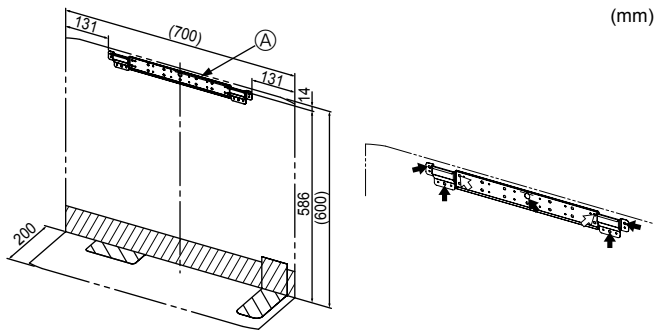

Fig. 3-1

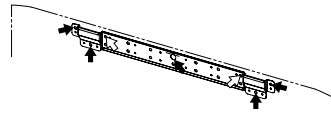

Fig. 3-2

3.1. Indoor unit mounting bracket installation

- Install the bracket firmly to the wall structure (stud, etc.). (Fig. 3-1)
- Use a level to install the mounting bracket horizontally.
- Install the indoor unit 150 mm or below from the floor.

① Indoor unit mounting bracket

Note:

To prevent the indoor unit mounting bracket from vibrating slightly, be sure to fasten the bracket at the holes indicated by . In addition, fasten the bracket at the holes indicated by if possible. (Fig. 3-2)

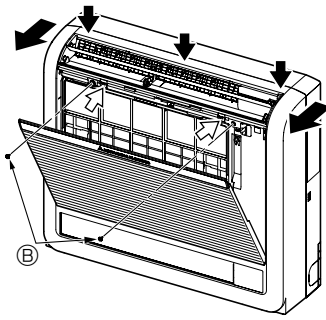

Fig. 3-3

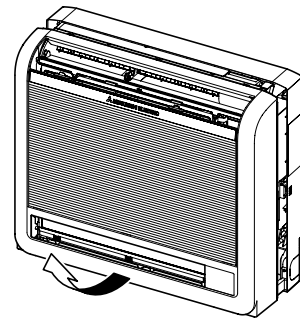

Fig. 3-4

3.2. Indoor unit preparation

- ① Press the 2 positions indicated by the arrows and open the front grille. (Fig. 3-3)
- ② Open the front grille and remove the 2 screws.
- ③ Open the horizontal vane for the upper air outlet, push the top of the front panel in 3 locations, and then pull the top of the grille away from the indoor unit.
 - ③ Screws
- ④ Lift up the front grille to remove it. (Fig. 3-4)

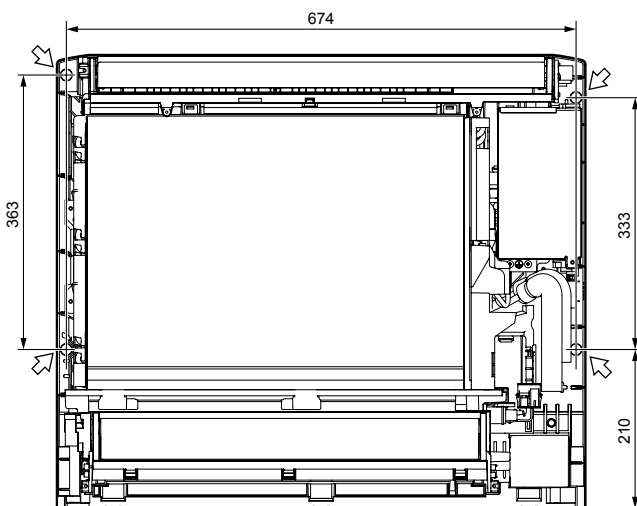

Fig. 3-5

3.3. Indoor unit installation (Fig. 3-5)

- Hook the top of the indoor unit on the indoor unit mounting bracket.
- Use the included wood screws and washer, and fasten the indoor unit at 2 locations () each at the top and the middle of the unit.

Note:

Install the indoor unit securely to the wall, making sure that there is no gap between the unit and the wall.

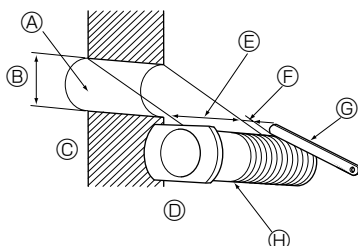

Fig. 3-6

3.4. Making holes in the wall and floor

3.4.1. Making holes (Fig. 3-6)

- ① Make $\varnothing 65$ mm or $\varnothing 75$ mm holes that are approximately 5–7 mm deep and angled slightly downward outward from the room.
- ② Insert the wall hole sleeves into the holes.

- ① Wall hole
- ② 65 mm or 75 mm dia.
- ③ Indoor side
- ④ Wall hole cross section
- ⑤ Wall thickness
- ⑥ One scale
- ⑦ Cut with 1 extra scale length.
- ⑧ Wall hole sleeve

⚠ Caution:

Be sure to use the wall hole sleeves. Otherwise, the indoor/outdoor unit connecting wires may contact a metal object in the wall or, in the case of hollow walls, small rodents may gnaw on the wires, resulting in a very dangerous situation.

3.4.2. Determining hole positions

The areas where the piping can be routed are indicated with oblique lines in the figure.

1) For rear or left-rear piping (Fig. 3-7)

(The following figure is a front view of the indoor unit installation location.)

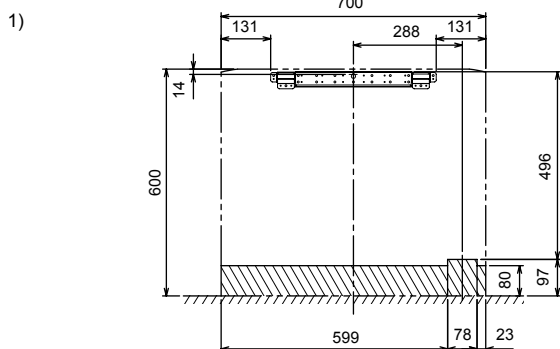

Fig. 3-7

3. Installing the indoor unit

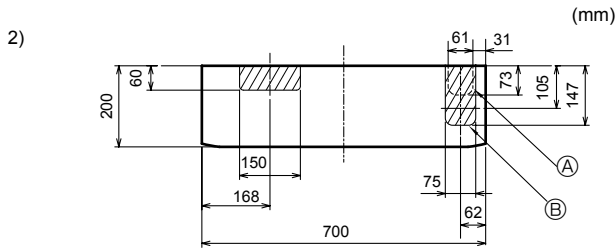

Fig. 3-8

2) For right downward or left downward piping (Fig. 3-8)

(The following figure is a view of the bottom of the indoor unit from above.)

- Ⓐ When the unit is installed on the wall.
- Ⓑ When the unit is installed on the floor.

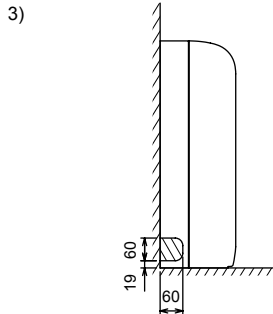

Fig. 3-9

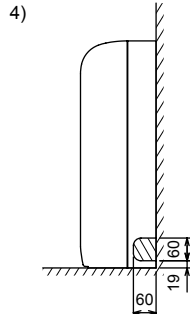

Fig. 3-10

3) For left piping (Fig. 3-9)

4) For right piping (Fig. 3-10)

3.4.3. Sealing the holes

Use putty or a caulking compound to seal the holes.

4. Refrigerant pipe

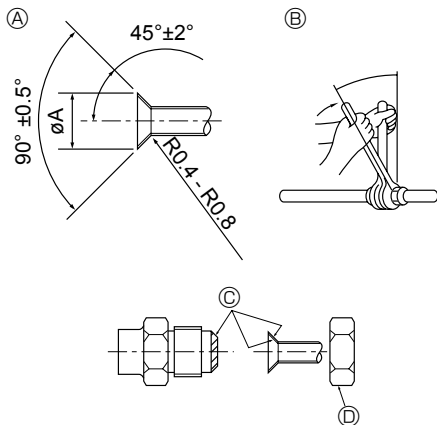

Fig. 4-1

4.1. Connecting pipes (Fig. 4-1)

- When commercially available copper pipes are used, wrap liquid and gas pipes with commercially available insulation materials (heat-resistant to 100°C or more, thickness of 12 mm or more).
- The indoor parts of the drain pipe should be wrapped with polyethylene foam insulation materials (specific gravity of 0.03, thickness of 9 mm or more).
- Apply thin layer of refrigerant oil to pipe and joint seating surface before tightening flare nut.
- Use two wrenches to tighten piping connections.
- Use refrigerant piping insulation provided to insulate indoor unit connections. Insulate carefully.

⚠ Warning:

When installing the unit, securely connect the refrigerant pipes before starting the compressor.

Ⓐ Flare cutting dimensions

Copper pipe O.D. (mm)	Flare dimensions øA dimensions (mm)
ø6.35	8.7 - 9.1
ø9.52	12.8 - 13.2
ø12.7	16.2 - 16.6
ø15.88	19.3 - 19.7
ø19.05	23.6 - 24.0

Ⓑ Refrigerant pipe sizes & Flare nut tightening torque

	R407C or R22				R410A				Flare nut O.D.	
	Liquid pipe		Gas pipe		Liquid pipe		Gas pipe		Liquid pipe (mm)	Gas pipe (mm)
	Pipe size (mm)	Tightening torque (N·m)	Pipe size (mm)	Tightening torque (N·m)	Pipe size (mm)	Tightening torque (N·m)	Pipe size (mm)	Tightening torque (N·m)		
P20/25/32/40	O.D. ø6.35 (1/4")	14 - 18	O.D. ø12.7 (1/2")	49 - 61	O.D. ø6.35 (1/4")	14 - 18	O.D. ø12.7 (1/2")	49 - 61	17	26

Ⓒ Apply refrigerating machine oil over the entire flare seat surface.

* Do not apply refrigerating machine oil to the screw portions. (This will make the flare nuts more apt to loosen.)

Ⓓ Be certain to use the flare nuts those are attached to the main unit. (Use of commercially-available products may result in cracking.)

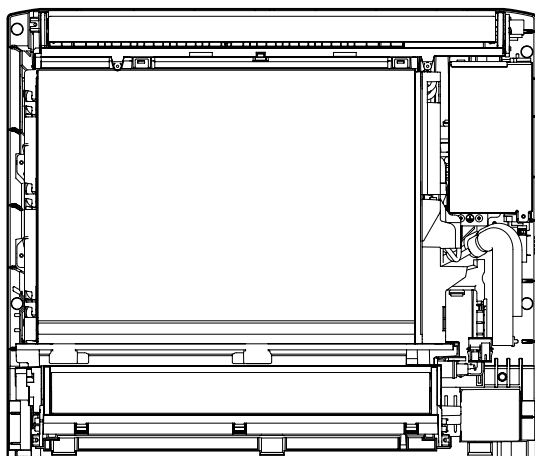

Fig. 4-2

4.2. Refrigerant piping

4.2.1. Connecting pipe installation

Install the connecting pipes so that the piping can move slightly to the front, back, left, and right. (Fig. 4-2)

4. Refrigerant pipe

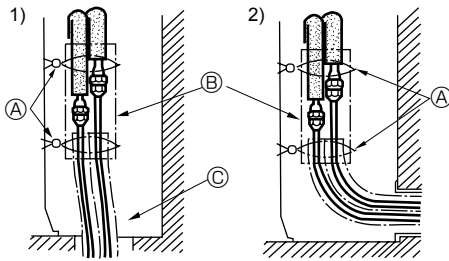

Fig. 4-3

Fig. 4-4

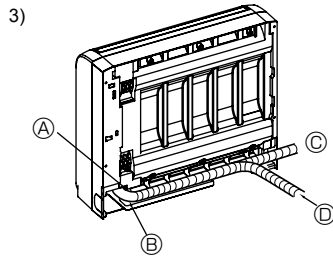

Fig. 4-5

Installing flush against a wall with molding

For left or right piping

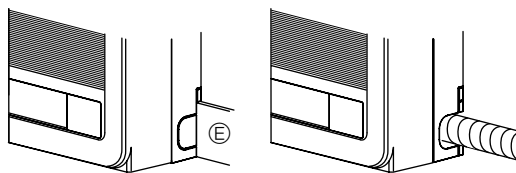

Fig. 4-6

1) For right downward piping (Fig. 4-3)

2) For piping other than right downward (Fig. 4-4)

- Ⓐ Bands
- Ⓑ Pipe covers
- Ⓒ Remove the cover.

- Be sure to insulate the connecting pipes and place them near the rear of the indoor unit so that they do not contact the front panel.
- Be careful not to crush the connecting pipes when bending them.

3) For left or left-rear piping (Fig. 4-5)

Bundle the connecting pipes and drain hose together, and then wrap them in felt tape.

- Ⓐ Make sure that the drain hose is not routed upward.

- Ⓑ Felt tape

* Wrap the felt tape tightly around the pipes and hose starting near where the pipes and hose are routed from the indoor unit. (The overlap width of the felt tape should not be more than 1/2 of the tape width.)

- Ⓒ Start wrapping the piping tape around the pipes and hose 10 mm inside the indoor unit.

- Ⓓ Fasten the end of the felt tape with a bandage stopper.

Cut and use the lower side panels on the left and right sides of the indoor unit as shown.

Smooth the cut edges of the side panels so that they will not damage the insulation coating. (Fig. 4-6)

- Ⓔ Cut the lower side panels to match the height of the modelling.

5. Drainage piping work

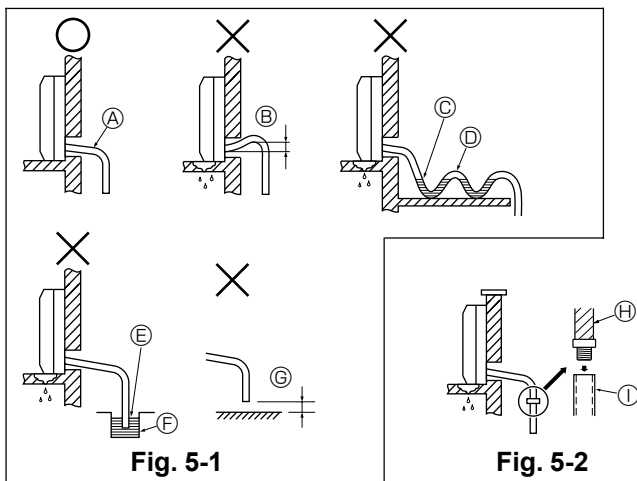

Fig. 5-1

Fig. 5-2

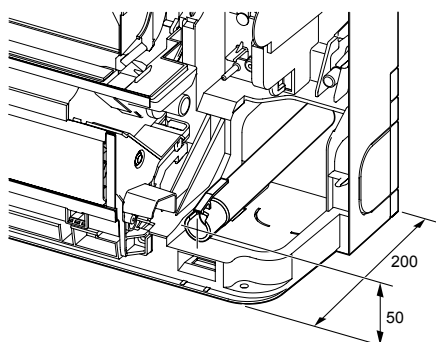

Fig. 5-3

5.1. Drainage piping work

- Be sure to route the drain piping slightly downward (1/100 or more) so that the drain water flows easily.
- Do not route the drain piping as shown in the examples mark with an "X" in the figure. (Fig. 5-1)
- If the drain hose is too short, refer to Fig. 5-2 to extend the length of the hose.
- If the indoor unit is installed in a high location such as a high-rise apartment, strong winds may cause the drain water to flow back through the drain hose and leak from the unit. If necessary, contact your nearest Mitsubishi Electric representative for the optional parts to prevent this problem.
- If the drain hose is routed indoors, be sure to wrap it in commercially-available insulation.
- Do not connect the drain piping directly to a septic tank, sewage tank, etc., where ammonia gases or hydrogen sulfide are produced.
- If there is slack in the drain hose or the end of the drain hose is raised up, the drain water may not flow smoothly and some drain water may collect in the hose. This can lead to a strange sound (bubbling) being produced during strong winds or when a ventilation fan, etc., is used in a residence that is well-sealed. If necessary, contact your nearest Mitsubishi Electric representative for the optional parts to prevent this problem.

- Ⓐ Sloping downward
- Ⓑ No upward slope
- Ⓒ Accumulated drain water
- Ⓓ Air
- Ⓔ End of drain hose is immersed in water.
- Ⓕ Drainage channel
- Ⓖ 50 mm or less from ground
- Ⓗ Drain hose
- Ⓘ Fixable PVC hose (inner diameter: 15 mm) or rigid PVC pipe (VP-15)

- When routing the drain piping, make sure that the drain hose is routed as shown. (Fig. 5-3)

5. Drainage piping work

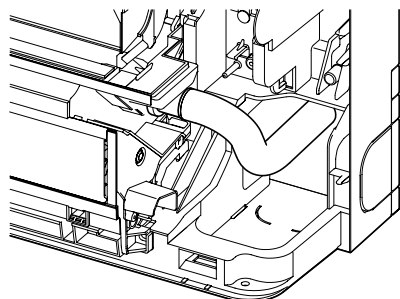

Fig. 5-4

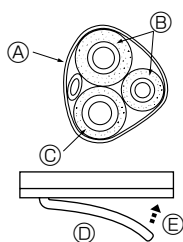

Fig. 5-5

- Insert the drain hose all the way to the base of the drain pan. (Fig. 5-4) Make sure that the drain hose is securely caught on the projection in the hole in the drain pan.

- Route the drain hose diagonally below the connecting pipes. (Fig. 5-5)
 - Ⓐ Piping tape
 - Ⓑ Refrigerant piping
 - Ⓒ Drain hose
- Make sure that the drain hose is not routed upward and that there are no waves in the hose.
- Do not pull the drain hose, and then wrap tape around it.
- Route the piping so that it does not project past the rear of the indoor unit. (Refer to the figure to the left.)
 - Ⓓ Piping bent outward
 - Ⓔ Push

6. Embedding the indoor unit in a wall

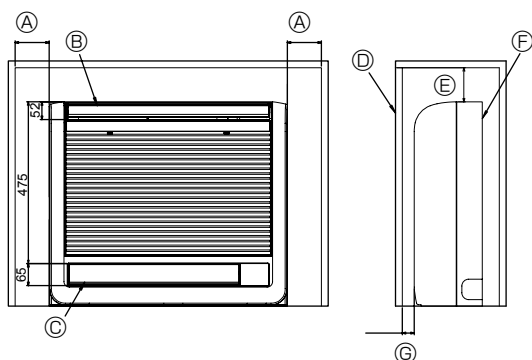

Fig. 6-1

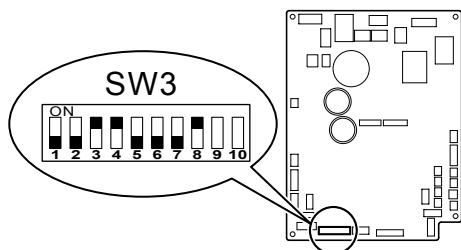

Fig. 6-2

6.1. Embedding the indoor unit in a wall (Fig. 6-1)

- On the indoor unit and right and left space (100 mm or more) are the service space.
- On a right side of the indoor unit, there is a hole for the room temperature sensor, and do not close it, please.
- When installing a grating, use a grating with narrow upper and lower horizontal bars so that the airflow from the upper and lower air outlets does not contact the bars. If the horizontal bars will block the lower air outlet, use a stand, etc., to adjust the height of the indoor unit. If the upper or lower air outlet is blocked, the air conditioner will not be able to cool or warm the room well.
- Use a grating with vertical bars, etc., that has at least 75% open area. If the grating has horizontal bars or if the open area is less than 75%, performance could be reduced.
- When the indoor unit is embedded in a wall (built-in), the time it takes for the room temperature to reach the set temperature will increase.
 - Ⓐ 100 mm or more
 - Ⓑ Upper air outlet
 - Ⓒ Lower air outlet
 - Ⓓ Grating
 - Ⓔ 100 mm or more
 - Ⓕ Indoor unit
 - Ⓖ 35 mm or more

6.2. Embedded indoor unit setting (must be performed) (Fig. 6-2)

- When embedding the indoor unit in a wall, restrict the movement of the horizontal vane for the upper air outlet so that it only operates horizontally.
- If this setting is not performed, heat will build up in the wall and the room will not be cooled or warmed properly.
- Remove the electrical part cover and pull out the control board.
- Set DIP switches 3-5 and 3-6 on the control board to ON.
- After setting the switches, reinstall the control board in its original position and install the electrical part cover.

⚠ Caution:

To avoid damage to the control board due to static electricity, be sure to discharge the static buildup before handling it.

7. Electrical work

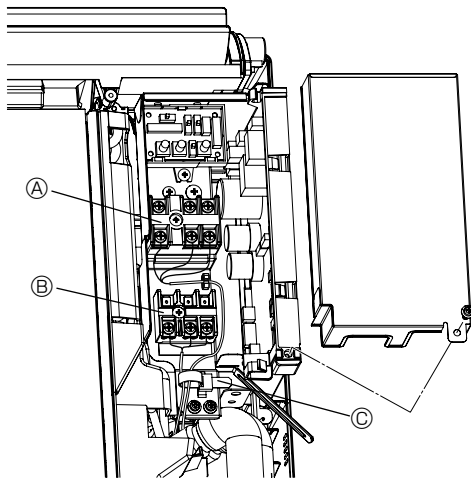

- Ⓐ Power supply terminal block (TB2)
- Ⓑ Transmission terminal block (TB5)
- Ⓒ Wiring clamp

Fig. 7-1

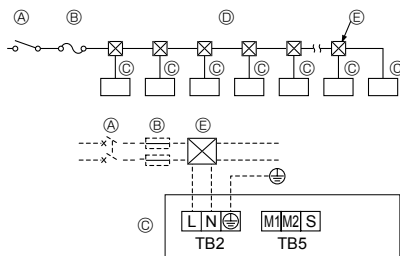

Fig. 7-2

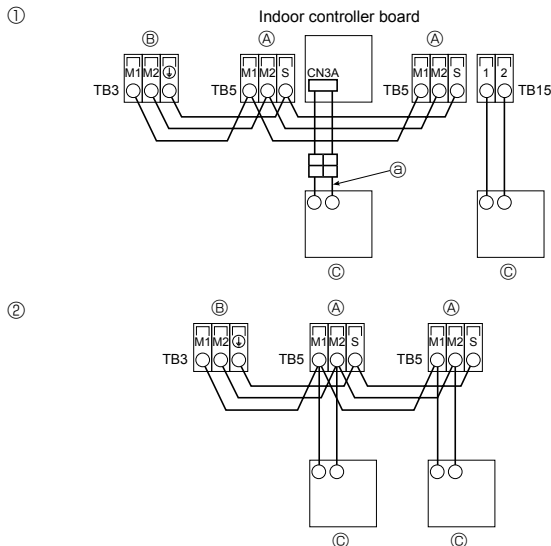

Fig. 7-3

7.1. Indoor unit (Fig. 7-1)

① Remove the electrical cover.

- Remove 1 screw holding the electrical cover, then move the cover.
- Remove 1 screw holding the cord clamp, then move the clamp.

② Connect the power line, control line from the outdoor unit, and remote control lines.

After connecting, secure the wires with the cord clamp.

► Fix power source wiring to control box using buffer bushing for tensile force. (PG connection or the like.)

- Since the electric box may need to be pulled out for servicing or other occasions, wires must have enough slack.
- Class 3 grounding work must be conducted (grounding wire diameter: 1.6 mm or more)

After wiring is completed, reinstall the parts in the reverse order of removal.

7.2. Power supply wiring

- Wiring size must comply with the applicable local and national codes.
- Install an earth line longer than other cables.
- Power supply codes of appliance shall not be lighter than design 60245 IEC 53 or 60227 IEC 53.
- A switch with at least 3 mm contact separation in each pole shall be provided by the air conditioner installation.

Power cable size : more than 1.5mm² (3-core)

⚠ Warning:

Never splice the power cable or the indoor-outdoor connection cable, otherwise it may result in a smoke, a fire or communication failure.

► Use earth leakage breaker (NV).

For breaker, means shall be provided to ensure disconnection of all active phase conductors of the supply.

⚠ Warning:

Wiring should be done so that the power lines are not subject to tension. Otherwise, heat may be generated or fire may occur.

[Fig. 7-2]

- Ⓐ Switch 16 A
- Ⓑ Overcurrent protection 16 A
- Ⓒ Indoor unit
- Ⓓ Total operating current be less than 16 A
- Ⓔ Pull box

7.3. Types of control cables

1. Wiring transmission cables

Types of transmission cable	Shielding wire CVVS or CPEVS
Cable diameter	More than 1.25 mm ²
Length	Less than 200m

2. M-NET Remote control cables

Types of remote control cable	Shielding wire MVVS
Cable diameter	0.5 to 1.25 mm ²
Length	Add any portion in excess of 10m to within the longest allowable transmission cable length 200m

3. MA Remote control cables

Types of remote control cable	2-core cable (unshielded)
Cable diameter	0.3 to 1.25 mm ²
Length	Less than 200m

7.4. Connecting remote controller, indoor and outdoor transmission cables (Fig. 7-3)

- Connect indoor unit TB5 and outdoor unit TB3. (Non-polarized 2-wire)
 - The "S" on indoor unit TB5 is a shielding wire connection. For specifications about the connecting cables, refer to the outdoor unit installation manual.
- Install a remote controller following the manual supplied with the remote controller.
- Connect the remote controller's transmission cable within 10 m using a 0.75 mm² core cable. If the distance is more than 10 m, use a 1.25 mm² junction cable.
 - ① MA Remote controller
 - Connect the connector for MA remote controller. (Non-polarized 2-wire)
 - DC 9 to 13 V between 1 and 2 (MA remote controller)
 - ⓐ MA remote controller cable (ACCESSORY ②)
 - ② M-NET Remote controller
 - Connect the "M1" and "M2" on indoor unit TB5 to a M-NET remote controller. (Non-polarized 2-wire)
 - DC 24 to 30 V between M1 and M2 (M-NET remote controller)
 - Ⓐ Terminal block for indoor transmission cable
 - Ⓑ Terminal block for outdoor transmission cable
 - Ⓒ Remote controller

7. Electrical work

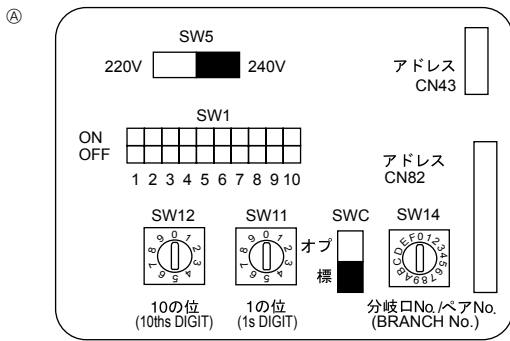

Fig. 7-4

7.5. Setting addresses (Fig. 7-4)

(Be sure to operate with the main power turned OFF.)

- There are 2 types of rotary switch setting available: setting addresses 1 to 9 and over 10, and setting branch numbers.

① How to set addresses

Example: If Address is "3", remain SW12 (for over 10) at "0", and match SW11 (for 1 to 9) with "3".

② How to set branch numbers SW14 (Series R2 only)

Match the indoor unit's refrigerant pipe with the BC controller's end connection number.

Remain other than series R2 at "0".

- The rotary switches are all set to "0" when shipped from the factory. These switches can be used to set unit addresses and branch numbers at will.
- The determination of indoor unit addresses varies with the system at site. Set them referring to the Data Book.

Note:

- Please set the switch SW5 according to the power supply voltage.
- Set SW5 to 240 V side when the power supply is 230 and 240 volts.
- When the power supply is 220 volts, set SW5 to 220 V side.

Ⓐ Address board

7.6. Sensing room temperature with the built-in sensor in a remote controller (Fig. 7-4)

If you want to sense room temperature with the built-in sensor in a remote controller, set SW1-1 on the control board to "ON". The setting of SW1-7 and SW1-8 as necessary also makes it possible to adjust the air flow at a time when the heating thermometer is OFF.

8. Test run

8.1. Before test run

- ▶ After completing installation and the wiring and piping of the indoor and outdoor units, check for refrigerant leakage, looseness in the power supply or control wiring, wrong polarity, and no disconnection of one phase in the supply.
- ▶ Use a 500-volt megohmmeter to check that the resistance between the power supply terminals and ground is at least 1.0 MΩ.

- ▶ Do not carry out this test on the control wiring (low voltage circuit) terminals.

⚠ Warning:

Do not use the air conditioner if the insulation resistance is less than 1.0 MΩ.

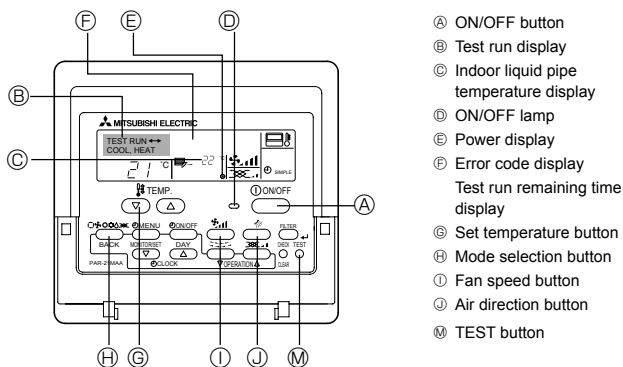

Fig. 8-1

8.2. Test run (Using wired remote controller) (Fig 8-1)

- ① Turn on the power at least 12 hours before the test run.
- ② Press the [TEST] button twice. ➡ "TEST RUN" liquid crystal display
- ③ Press the [Mode selection] button. ➡ Make sure that wind is blown out.
- ④ Press the [Mode selection] button and switch to the cooling (or heating) mode. ➡ Make sure that cold (or warm) wind is blown out.
- ⑤ Press the [Fan speed] button. ➡ Make sure that the wind speed is switched.
- ⑥ Check operation of the outdoor unit fan.
- ⑦ Release test run by pressing the [ON/OFF] button. ➡ Stop
- ⑧ Register a telephone number.

The telephone number of the repair shop, sales office, etc., to contact if an error occurs can be registered in the remote controller. The telephone number will be displayed when an error occurs. For registration procedures, refer to the operation manual for the indoor unit.

Note:

- If an error code is displayed on the remote controller or if the air conditioner does not operate properly, refer to the outdoor unit installation manual or other technical materials.
- The OFF timer is set for the test run to automatically stop after 2 hours.
- During the test run, the time remaining is shown in the time display.
- During the test run, the temperature of the indoor unit refrigerant pipes is shown in the room temperature display of the remote controller.
- When the VANE or LOUVER button is pressed, the message "NOT AVAILABLE" may appear on the remote controller display depending on the indoor unit model, but this is not a malfunction.
- For the PFFY-P-VKM series, the airflow direction displayed on the remote controller is different from the actual airflow direction. Refer to the following table.

8. Test run

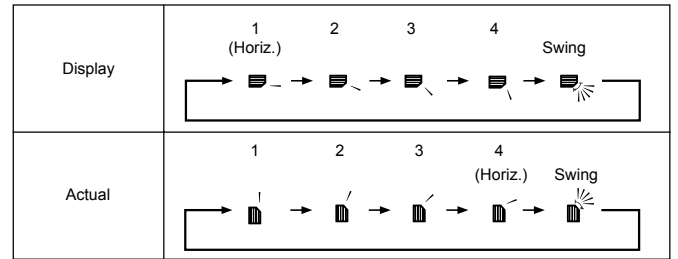

- The lower air outlet damper automatically opens and closes according to the piping temperature, intake air temperature, and operation time. The airflow direction cannot be set.

9. Air outlet selection

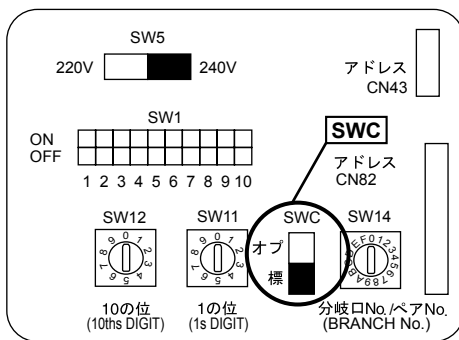

Fig. 9-1



With this function, air comes out simultaneously from the upper and lower air outlets so that the room can be cooled or heated effectively. This function is set using the switch SWC on the address board.

How to set to blow out air from the upper and lower air outlets:

- ▶ Set the SWC to lower side (“標”). (Initial setting)

Air blows out automatically from the upper and lower air outlets as shown in the table below.

How to set to blow out air from the upper air outlet only:

- ▶ Set the SWC to upper side (“オフ”).

Note:

Be sure to operate with the main power turned off.

Description of operation

Operation	COOL		DRY	HEAT		FAN
Air flow	 Upper and lower air flow	 Upper air flow	 Upper air flow only	 Upper and lower air flow	 Upper air flow	 Upper and lower air flow
Conditions	Room temperature and set temperature are different.	Room temperature is close to set temperature or thermo-off.	—	(Normal condition (in heating))	During defrosting operation, start of operation, thermo-off	—

- Be sure to keep the area around the damper of the lower air outlet free of any objects.

This product is designed and intended for use in the residential,
commercial and light-industrial environment.

The product at hand is
based on the following
EU regulations:

- Low Voltage Directive 2006/95/EC
- Electromagnetic Compatibility Directive 2004/108/EC
- Machinery Directive 2006/42/EC
- Energy-related Products Directive 2009/125/EC

Please be sure to put the contact address/telephone number on
this manual before handing it to the customer.

mitsubishi electric corporation

HEAD OFFICE: TOKYO BLDG., 2-7-3, MARUNOUCHI, CHIYODA-KU, TOKYO 100-8310, JAPAN

Authorized representative in EU: MITSUBISHI EUROPE, B.V. HARMAN HOUSE,

1 GEORGE STREET, UXBRIDGE,

MIDDLE SEX UB8 1QQ.U.K.