

SERVICE PARTS LIST FOR MITSUBISHI ELECTRIC PACKAGED AIR-CONDITIONERS

Series : PU(H)Y-P•YGM-A(-BS)

For use with the R410A

REVISED

July 2007

BWE0412C

INDEX

PU(H)Y-P200YGM-A(-BS)
PU(H)Y-P250YGM-A(-BS)
PU(H)Y-P300YGM-A(-BS)
PU(H)Y-P350YGM-A(-BS)
PUHY-P400YGM-A(-BS)
PUHY-P450YGM-A(-BS)
PUHY-P500YGM-A(-BS)
PUHY-P550YGM-A(-BS)
PUHY-P600YGM-A(-BS)
PUHY-P650YGM-A(-BS)



PU(H)Y-P200, P250YGM-A(-BS)
PU(H)Y-P300, P350YGM-A(-BS)

EXTERNAL PARTS & BLOWER PARTS (1)

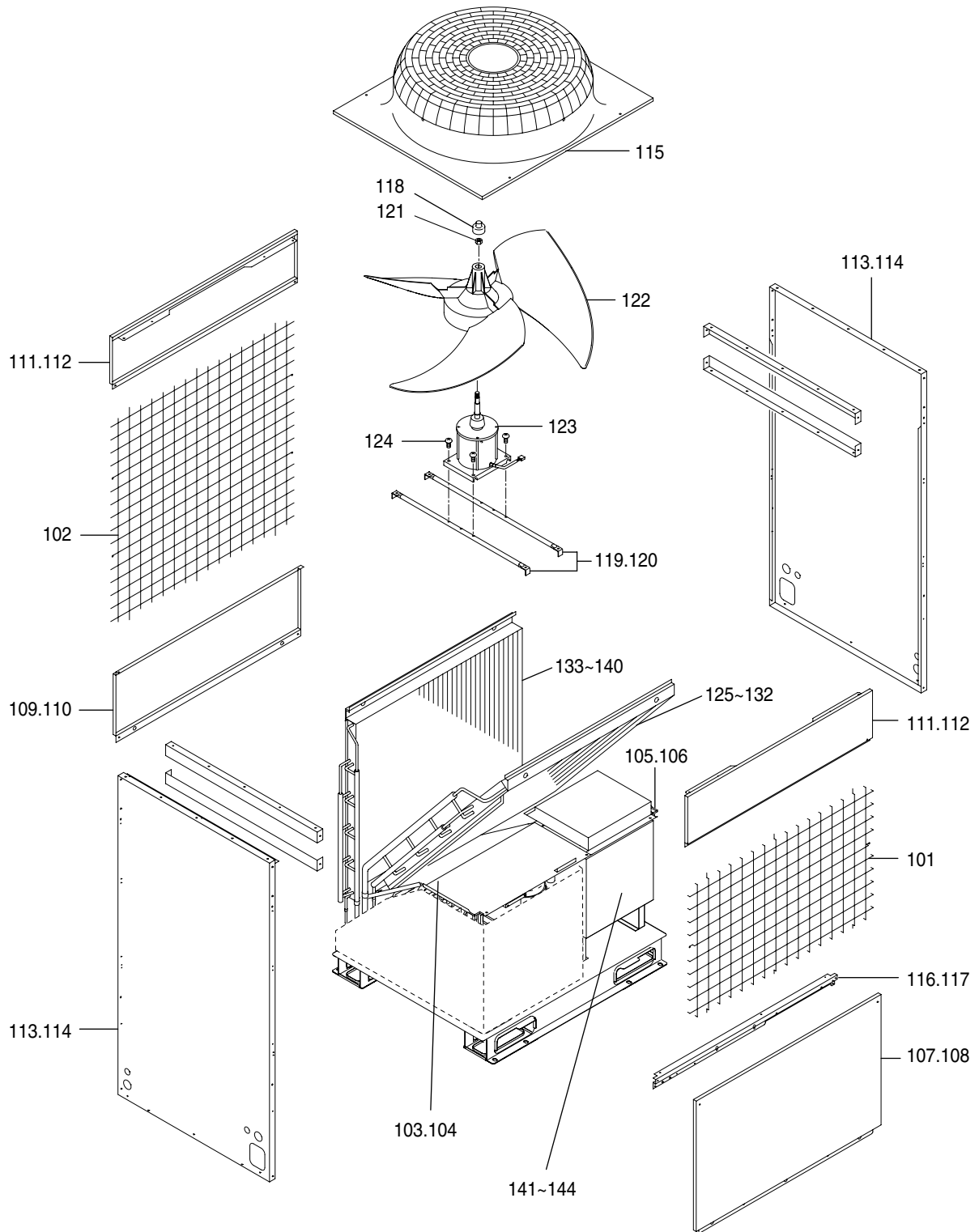

No.	Part No.	G : RoHS Apply Only W : RoHS Apply by Running Change		Spec.	PUY-P200YGM-A	PUY-P250YGM-A	PUY-P300YGM-A	PUY-P350YGM-A	Dwg. No.	Price	Revision History
			Part Name								
101	R63 E66 611	G	Guard F assy		1	1	1	1	W265788G01		
102	R63 A42 638	G	Guard B assy		1	1	1	1	W265789G01		
103	R63 R34 667	G	Partition board L assy		1	1	1	1	W656425G01		
104	R63 R35 667	G	Partition board L assy						W656425G02		
105	R63 R37 668	G	Partition board R assy		1	1	1	1	W656424G01		
106	R63 R38 668	G	Partition board R assy						W656424G02		
107	R63 R34 651	G	Panel F		1	1	1	1	W655252H01		
108	R63 R36 651	G	Panel F						W655252G02		
109	R63 Y32 652	G	Panel B		1	1	1	1	W655227H02		
110	R63 R36 677	G	Panel B						W655227G04		
111	R63 L78 653	G	Panel FU		2	2	2	2	W633746H06		
112	R63 R36 652	G	Panel FU						W633746G07		
113	R63 N78 661	G	Panel S		2	2	2	2	W272421H01		
114	R63 R36 661	G	Panel S						W272421G03		
115	R63 N78 118	G	Fan guard		1	1	1	1	W126832G02		
116	R63 A42 659	G	Panel support		1	1	1	1	W615888H18		
117	R63 A43 659	G	Panel support						W615888G09		
118	R61 A69 086	G	Cap		1	1	1	1	P221056X01		
119	R63 A42 140	G	Fan stand		2	2	2	2	W856127G05		
120	R63 A43 140	G	Fan stand						W856127G06		
121	R63 A42 122	G	Nut 16		1	1	1	1	P541016X01		
122	R63 N78 115	G	Propeller fan	750D	1	1	1	1	W126814G01		
123	R63 Y43 221	G	Motor YC380IA	342V 33Hz	1	1	1	1	P714969X01		
124	R63 E90 087	G	Screw 6×14		4	4	4	4	P521020X01		
125	R63 Y04 482	G	Heat exchanger F		1				W656448G23		
126	R63 R36 480	G	Heat exchanger F						W656448G17		
127	R63 Y09 482	G	Heat exchanger F			1			W656448G28		
128	R63 R54 480	G	Heat exchanger F						W656448G21		
129	R63 Y09 482	G	Heat exchanger F				1		W656448G28		
130	R63 R54 480	G	Heat exchanger F						W656448G21		
131	R63 Y09 482	G	Heat exchanger F					1	W656448G28		
132	R63 R54 480	G	Heat exchanger F						W656448G21		
133	R63 Y11 482	G	Heat exchanger B		1				W656450G23		
134	R63 R36 481	G	Heat exchanger B						W656450G17		
135	R63 Y16 482	G	Heat exchanger B			1			W656450G28		
136	R63 R54 481	G	Heat exchanger B						W656450G21		
137	R63 Y16 482	G	Heat exchanger B				1		W656450G28		C
138	R63 R54 481	G	Heat exchanger B						W656450G21		
139	R63 Y16 482	G	Heat exchanger B					1	W656450G28		
140	R63 R54 481	G	Heat exchanger B						W656450G21		
141	R63 Y62 305	G	Control box	PUY-P200	1				KE00C068G06		
142	R63 Y63 305	G	Control box	PUY-P250		1	1	1	KE00C068G07		
143	R63 Y57 305	G	Control box	P200YGM					KE00C068G01		
144	R63 Y58 305	G	Control box	P250YGM					KE00C068G02		

No.	Part No.	G : RoHS Apply Only W : RoHS Apply by Running Change		Spec.	PUY-P200YGM-A-BS	PUY-P250YGM-A-BS	PUY-P300YGM-A-BS	PUY-P350YGM-A-BS	Dwg. No.	Price	Revision History
			Part Name								
101	R63 E66 611	G	Guard F assy		1	1	1	1	W265788G01		
102	R63 A42 638	G	Guard B assy		1	1	1	1	W265789G01		
103	R63 R34 667	G	Partition board L assy						W656425G01		
104	R63 R35 667	G	Partition board L assy		1	1	1	1	W656425G02		
105	R63 R37 668	G	Partition board R assy						W656424G01		
106	R63 R38 668	G	Partition board R assy		1	1	1	1	W656424G02		
107	R63 R34 651	G	Panel F						W655252H01		
108	R63 R36 651	G	Panel F		1	1	1	1	W655252G02		
109	R63 Y32 652	G	Panel B						W655227H02		
110	R63 R36 677	G	Panel B		1	1	1	1	W655227G04		
111	R63 L78 653	G	Panel FU						W633746H06		
112	R63 R36 652	G	Panel FU		2	2	2	2	W633746G07		
113	R63 N78 661	G	Panel S						W272421H01		
114	R63 R36 661	G	Panel S		2	2	2	2	W272421G03		
115	R63 N78 118	G	Fan guard		1	1	1	1	W126832G02		
116	R63 A42 659	G	Panel support						W615888H18		
117	R63 A43 659	G	Panel support		1	1	1	1	W615888G09		
118	R61 A69 086	G	Cap		1	1	1	1	P221056X01		
119	R63 A42 140	G	Fan stand						W856127G05		
120	R63 A43 140	G	Fan stand		2	2	2	2	W856127G06		
121	R63 A42 122	G	Nut 16		1	1	1	1	P541016X01		
122	R63 N78 115	G	Propeller fan	750D	1	1	1	1	W126814G01		
123	R63 Y43 221	G	Motor YC380IA	342V 33Hz	1	1	1	1	P714969X01		
124	R63 E90 087	G	Screw 6×14		4	4	4	4	P521020X01		
125	R63 Y04 482	G	Heat exchanger F						W656448G23		
126	R63 R36 480	G	Heat exchanger F		1				W656448G17		
127	R63 Y09 482	G	Heat exchanger F						W656448G28		
128	R63 R54 480	G	Heat exchanger F			1			W656448G21		
129	R63 Y09 482	G	Heat exchanger F						W656448G28		
130	R63 R54 480	G	Heat exchanger F				1		W656448G21		
131	R63 Y09 482	G	Heat exchanger F						W656448G28		
132	R63 R54 480	G	Heat exchanger F					1	W656448G21		
133	R63 Y11 482	G	Heat exchanger B						W656450G23		
134	R63 R36 481	G	Heat exchanger B		1				W656450G17		
135	R63 Y16 482	G	Heat exchanger B						W656450G28		
136	R63 R54 481	G	Heat exchanger B			1			W656450G21		
137	R63 Y16 482	G	Heat exchanger B						W656450G28		C
138	R63 R54 481	G	Heat exchanger B				1		W656450G21		
139	R63 Y16 482	G	Heat exchanger B						W656450G28		
140	R63 R54 481	G	Heat exchanger B					1	W656450G21		
141	R63 Y62 305	G	Control box	PUY-P200	1				KE00C068G06		
142	R63 Y63 305	G	Control box	PUY-P250		1	1	1	KE00C068G07		
143	R63 Y57 305	G	Control box	P200YGM					KE00C068G01		
144	R63 Y58 305	G	Control box	P250YGM					KE00C068G02		

PU(H)Y-P200, P250YGM-A(-BS)
 PU(H)Y-P300, P350YGM-A(-BS)

EXTERNAL PARTS & BLOWER PARTS (1)

No.	Part No.	G : RoHS Apply Only W : RoHS Apply by Running Change		Spec.	PUHY-P200YGM-A	PUHY-P250YGM-A	PUHY-P300YGM-A	PUHY-P350YGM-A	Dwg. No.	Price	Revision History
			Part Name								
101	R63 E66 611	G	Guard F assy		1	1	1	1	W265788G01		
102	R63 A42 638	G	Guard B assy		1	1	1	1	W265789G01		
103	R63 R34 667	G	Partition board L assy		1	1	1	1	W656425G01		
104	R63 R35 667	G	Partition board L assy						W656425G02		
105	R63 R37 668	G	Partition board R assy		1	1	1	1	W656424G01		
106	R63 R38 668	G	Partition board R assy						W656424G02		
107	R63 R34 651	G	Panel F		1	1	1	1	W655252H01		
108	R63 R36 651	G	Panel F						W655252G02		
109	R63 Y32 652	G	Panel B		1	1	1	1	W655227H02		
110	R63 R36 677	G	Panel B						W655227G04		
111	R63 L78 653	G	Panel FU		2	2	2	2	W633746H06		
112	R63 R36 652	G	Panel FU						W633746G07		
113	R63 N78 661	G	Panel S		2	2	2	2	W272421H01		
114	R63 R36 661	G	Panel S						W272421G03		
115	R63 N78 118	G	Fan guard		1	1	1	1	W126832G02		
116	R63 A42 659	G	Panel support		1	1	1	1	W615888H18		
117	R63 A43 659	G	Panel support						W615888G09		
118	R61 A69 086	G	Cap		1	1	1	1	P221056X01		
119	R63 A42 140	G	Fan stand		2	2	2	2	W856127G05		
120	R63 A43 140	G	Fan stand						W856127G06		
121	R63 A42 122	G	Nut 16		1	1	1	1	P541016X01		
122	R63 N78 115	G	Propeller fan	750D	1	1	1	1	W126814G01		
123	R63 Y43 221	G	Motor YC380IA	342V 33Hz	1	1	1	1	P714969X01		
124	R63 E90 087	G	Screw 6×14		4	4	4	4	P521020X01		
125	R63 Y04 482	G	Heat exchanger F		1				W656448G23		
126	R63 R36 480	G	Heat exchanger F						W656448G17		
127	R63 Y09 482	G	Heat exchanger F			1			W656448G28		
128	R63 R54 480	G	Heat exchanger F						W656448G21		
129	R63 Y09 482	G	Heat exchanger F				1		W656448G28		
130	R63 R54 480	G	Heat exchanger F						W656448G21		
131	R63 Y09 482	G	Heat exchanger F					1	W656448G28		
132	R63 R54 480	G	Heat exchanger F						W656448G21		
133	R63 Y11 482	G	Heat exchanger B		1				W656450G23		
134	R63 R36 481	G	Heat exchanger B						W656450G17		
135	R63 Y16 482	G	Heat exchanger B			1			W656450G28		
136	R63 R54 481	G	Heat exchanger B						W656450G21		
137	R63 Y16 482	G	Heat exchanger B				1		W656450G28		C
138	R63 R54 481	G	Heat exchanger B						W656450G21		
139	R63 Y16 482	G	Heat exchanger B					1	W656450G28		
140	R63 R54 481	G	Heat exchanger B						W656450G21		
141	R63 Y62 305	G	Control box	PUY-P200					KE00C068G06		
142	R63 Y63 305	G	Control box	PUY-P250					KE00C068G07		
143	R63 Y57 305	G	Control box	P200YGM	1				KE00C068G01		
144	R63 Y58 305	G	Control box	P250YGM		1	1	1	KE00C068G02		

PU(H)Y-P200, P250YGM-A(-BS)
 PU(H)Y-P300, P350YGM-A(-BS)

EXTERNAL PARTS & BLOWER PARTS (1)

No.	Part No.	G : RoHS Apply Only W : RoHS Apply by Running Change		Spec.	PUHYP200YGM-A-BS	PUHYP250YGM-A-BS	PUHYP300YGM-A-BS	PUHYP350YGM-A-BS	Dwg. No.	Price	Revision History
			Part Name								
101	R63 E66 611	G	Guard F assy		1	1	1	1	W265788G01		
102	R63 A42 638	G	Guard B assy		1	1	1	1	W265789G01		
103	R63 R34 667	G	Partition board L assy						W656425G01		
104	R63 R35 667	G	Partition board L assy		1	1	1	1	W656425G02		
105	R63 R37 668	G	Partition board R assy						W656424G01		
106	R63 R38 668	G	Partition board R assy		1	1	1	1	W656424G02		
107	R63 R34 651	G	Panel F						W655252H01		
108	R63 R36 651	G	Panel F		1	1	1	1	W655252G02		
109	R63 Y32 652	G	Panel B						W655227H02		
110	R63 R36 677	G	Panel B		1	1	1	1	W655227G04		
111	R63 L78 653	G	Panel FU						W633746H06		
112	R63 R36 652	G	Panel FU		2	2	2	2	W633746G07		
113	R63 N78 661	G	Panel S						W272421H01		
114	R63 R36 661	G	Panel S		2	2	2	2	W272421G03		
115	R63 N78 118	G	Fan guard		1	1	1	1	W126832G02		
116	R63 A42 659	G	Panel support						W615888H18		
117	R63 A43 659	G	Panel support		1	1	1	1	W615888G09		
118	R61 A69 086	G	Cap		1	1	1	1	P221056X01		
119	R63 A42 140	G	Fan stand						W856127G05		
120	R63 A43 140	G	Fan stand		2	2	2	2	W856127G06		
121	R63 A42 122	G	Nut 16		1	1	1	1	P541016X01		
122	R63 N78 115	G	Propeller fan	750D	1	1	1	1	W126814G01		
123	R63 Y43 221	G	Motor YC380IA	342V 33Hz	1	1	1	1	P714969X01		
124	R63 E90 087	G	Screw 6×14		4	4	4	4	P521020X01		
125	R63 Y04 482	G	Heat exchanger F						W656448G23		
126	R63 R36 480	G	Heat exchanger F		1				W656448G17		
127	R63 Y09 482	G	Heat exchanger F						W656448G28		
128	R63 R54 480	G	Heat exchanger F			1			W656448G21		
129	R63 Y09 482	G	Heat exchanger F						W656448G28		
130	R63 R54 480	G	Heat exchanger F				1		W656448G21		
131	R63 Y09 482	G	Heat exchanger F						W656448G28		
132	R63 R54 480	G	Heat exchanger F					1	W656448G21		
133	R63 Y11 482	G	Heat exchanger B						W656450G23		
134	R63 R36 481	G	Heat exchanger B		1				W656450G17		
135	R63 Y16 482	G	Heat exchanger B						W656450G28		
136	R63 R54 481	G	Heat exchanger B			1			W656450G21		
137	R63 Y16 482	G	Heat exchanger B						W656450G28		C
138	R63 R54 481	G	Heat exchanger B				1		W656450G21		
139	R63 Y16 482	G	Heat exchanger B						W656450G28		
140	R63 R54 481	G	Heat exchanger B					1	W656450G21		
141	R63 Y62 305	G	Control box	PUY-P200					KE00C068G06		
142	R63 Y63 305	G	Control box	PUY-P250					KE00C068G07		
143	R63 Y57 305	G	Control box	P200YGM	1				KE00C068G01		
144	R63 Y58 305	G	Control box	P250YGM		1	1	1	KE00C068G02		

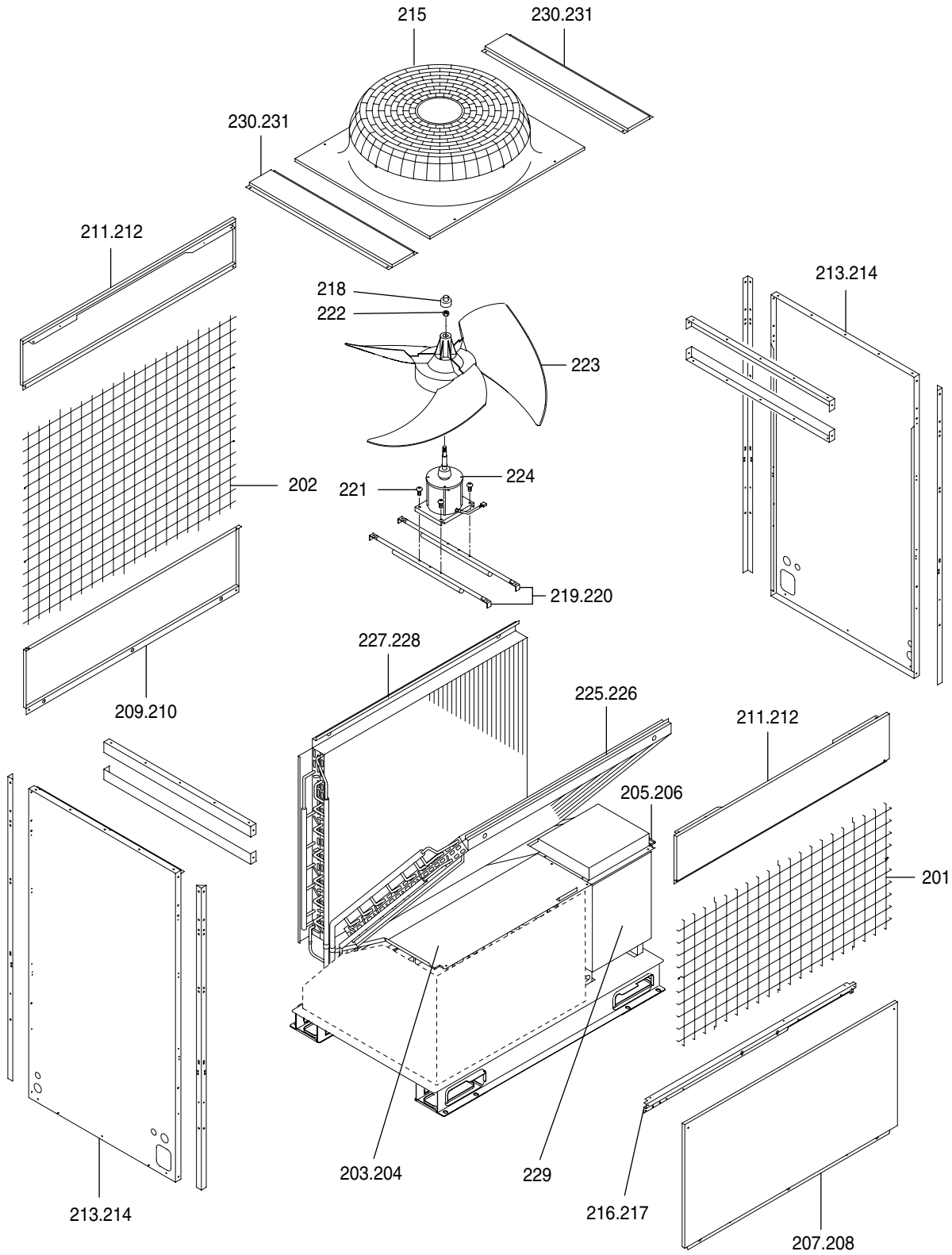

No.	Part No.	G : RoHS Apply Only W : RoHS Apply by Running Change		Spec.	PUHY-P400YGM-A	PUHY-P400YGM-A(-BS)		Dwg. No.	Price	Revision History
			Part Name							
201	R63 A52 637	G	Guard F assy		1	1		W265792G01		
202	R63 A52 638	G	Guard B assy		1	1		W265791G01		
203	R63 Y28 629	G	Partition board L assy		1			W657494G01		
204	R63 Y29 629	G	Partition board L assy			1		W657494G02		
205	R63 R37 668	G	Partition board R assy		1			W656424G01		
206	R63 R38 668	G	Partition board R assy			1		W656424G02		
207	R63 R55 651	G	Panel F		1			W655254H01		
208	R63 R57 651	G	Panel F			1		W655254G02		
209	R63 Y33 629	G	Panel B		1			W655225H02		
210	R63 R57 677	G	Panel B			1		W655225G04		
211	R63 M23 651	G	Panel FU		2			W633747H05		
212	R63 R57 652	G	Panel FU			2		W633747G05		
213	R63 N78 661	G	Panel S		2			W272421H01		
214	R63 R36 661	G	Panel S			2		W272421G03		
215	R63 N78 118	G	Fan guard		1	1		W126832G02		
216	R63 A52 659	G	Panel support		1			W615888H19		
217	R63 A53 659	G	Panel support			1		W615888G10		
218	R61 A69 086	G	Cap		1	1		P221056X01		
219	R63 432 140	G	Fan stand		2			W862595G01		
220	R63 433 140	G	Fan stand			2		W862595G02		
221	R63 E90 087	G	Screw 6x14		4	4		P521020X01		
222	R63 A42 122	G	Nut 16		1	1		P541016X01		
223	R63 N78 115	G	Propeller fan	750D	1	1		W126814G01		
224	R63 Y44 221	G	Motor EEOK-IOTV1 640W	342V 40.5Hz	1	1		P714970X01		
225	R63 Y17 482	G	Heat exchanger F		1			W276808G05		
226	R63 Y18 482	G	Heat exchanger F			1		W276808G02		
227	R63 Y19 482	G	Heat exchanger B		1			W276809G05		
228	R63 Y20 482	G	Heat exchanger B			1		W276809G02		
229	R63 Y59 305	G	Control box	P400YGM	1	1		KE00C068G03		
230	R63 P85 499	G	Cover assy		2			W653698G01		
231	R63 R57 667	G	Cover assy			2		W653698G03		

PUHY-P450, P500YGM-A(-BS)
PUHY-P550, P600YGM-A(-BS)
PUHY-P650YGM-A(-BS)

EXTERNAL PARTS & BLOWER PARTS (3)

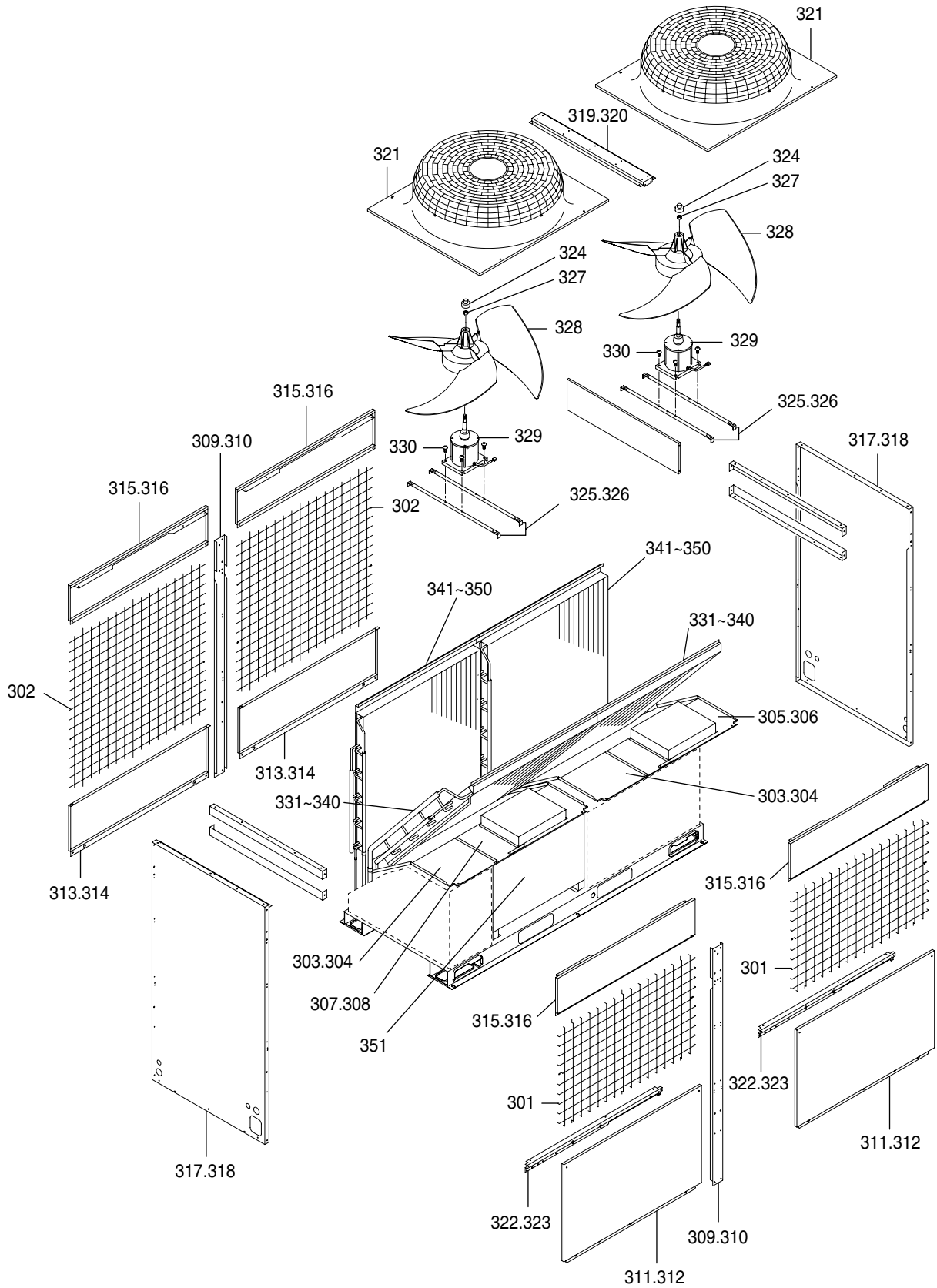

PUHY-P450, P500YGM-A(-BS)
 PUHY-P550, P600YGM-A(-BS)
 PUHY-P650YGM-A(-BS)

EXTERNAL PARTS & BLOWER PARTS (3)

No.	Part No.	G : RoHS Apply Only W : RoHS Apply by Running Change		Spec.	PUHY-P450YGM-A	PUHY-P500YGM-A	PUHY-P550YGM-A	PUHY-P600YGM-A	Dwg. No.	Price	Revision History
			Part Name								
301	R63 E66 611	G	Guard F assy		2	2	2	2	W265788G01		
302	R63 A42 638	G	Guard B assy		2	2	2	2	W265789G01		
303	R63 R34 667	G	Partition board L assy		2	2	2	2	W656425G01		
304	R63 R35 667	G	Partition board L assy						W656425G02		
305	R63 R43 668	G	Partition board R assy		1	1	1	1	W656424G03		
306	R63 R44 668	G	Partition board R assy						W656424G04		
307	R63 R43 667	G	Partition board R assy		1	1	1	1	W656424G05		
308	R63 R44 667	G	Partition board R assy						W656424G06		
309	R63 R43 626	G	Stay M		2	2	2	2	W656007G05		C
310	R63 R44 626	G	Stay M						W656007G02		
311	R63 R34 651	G	Panel F		2	2	2	2	W655252H01		
312	R63 R36 651	G	Panel F						W655252G02		
313	R63 Y32 652	G	Panel B		2	2	2	2	W655227H02		
314	R63 R36 677	G	Panel B						W655227G04		
315	R63 L78 653	G	Panel FU		4	4	4	4	W633746H06		
316	R63 R36 652	G	Panel FU						W633746G07		
317	R63 N78 661	G	Panel S		2	2	2	2	W272421H01		
318	R63 R36 661	G	Panel S						W272421G03		
319	R63 E66 125	G	Beam M		1	1	1	1	W623718G01		
320	R63 E67 125	G	Beam M						W623718G03		
321	R63 N78 118	G	Fan guard		2	2	2	2	W126832G02		
322	R63 A42 659	G	Panel support		2	2	2	2	W615888H18		
323	R63 A43 659	G	Panel support						W615888G09		
324	R61 A69 086	G	Cap		2	2	2	2	P221056X01		
325	R63 A42 140	G	Fan stand		4	4	4	4	W856127G05		
326	R63 A43 140	G	Fan stand						W856127G06		
327	R63 A42 122	G	Nut 16		2	2	2	2	P541016X01		
328	R63 N78 115	G	Propeller fan	750D	2	2	2	2	W126814G01		
329	R63 Y43 221	G	Motor YC380IA	342V 33Hz	2	2	2	2	P714969X01		
330	R63 E90 087	G	Screw 6x14		8	8	8	8	P521020X01		
331	R63 Y09 482	G	Heat exchanger F		2				W656448G28		
332	R63 R54 480	G	Heat exchanger F						W656448G21		
333	R63 Y09 482	G	Heat exchanger F			2			W656448G28		
334	R63 Y03 482	G	Heat exchanger F						W656448G22		
335	R63 Y09 482	G	Heat exchanger F				2		W656448G28		
336	R63 R54 480	G	Heat exchanger F						W656448G21		
337	R63 Y09 482	G	Heat exchanger F				2		W656448G28		
338	R63 R54 480	G	Heat exchanger F						W656448G21		
339	R63 Y09 482	G	Heat exchanger F						W656448G28		
340	R63 R54 480	G	Heat exchanger F						W656448G21		
341	R63 Y16 482	G	Heat exchanger B		2				W656450G28		
342	R63 R54 481	G	Heat exchanger B						W656450G21		
343	R63 Y16 482	G	Heat exchanger B			2			W656450G28		
344	R63 R54 481	G	Heat exchanger B						W656450G21		
345	R63 Y16 482	G	Heat exchanger B				2		W656450G28		

PUHY-P450, P500YGM-A(-BS)
 PUHY-P550, P600YGM-A(-BS)
 PUHY-P650YGM-A(-BS)

EXTERNAL PARTS & BLOWER PARTS (3)

No.	Part No.	G : RoHS Apply Only W : RoHS Apply by Running Change		Spec.	PUHY-P60YGM-A	PUHY-P450YGM-A-BS	PUHY-P500YGM-A-BS	PUHY-P550YGM-A-BS	Dwg. No.	Price	Revision History
			Part Name								
301	R63 E66 611	G	Guard F assy		2	2	2	2	W265788G01		
302	R63 A42 638	G	Guard B assy		2	2	2	2	W265789G01		
303	R63 R34 667	G	Partition board L assy		2				W656425G01		
304	R63 R35 667	G	Partition board L assy			2	2	2	W656425G02		
305	R63 R43 668	G	Partition board R assy		1				W656424G03		
306	R63 R44 668	G	Partition board R assy			1	1	1	W656424G04		
307	R63 R43 667	G	Partition board R assy		1				W656424G05		
308	R63 R44 667	G	Partition board R assy			1	1	1	W656424G06		
309	R63 R43 626	G	Stay M		2				W656007G05		C
310	R63 R44 626	G	Stay M			2	2	2	W656007G02		
311	R63 R34 651	G	Panel F		2				W655252H01		
312	R63 R36 651	G	Panel F			2	2	2	W655252G02		
313	R63 Y32 652	G	Panel B		2				W655227H02		
314	R63 R36 677	G	Panel B			2	2	2	W655227G04		
315	R63 L78 653	G	Panel FU		4				W633746H06		
316	R63 R36 652	G	Panel FU			4	4	4	W633746G07		
317	R63 N78 661	G	Panel S		2				W272421H01		
318	R63 R36 661	G	Panel S			2	2	2	W272421G03		
319	R63 E66 125	G	Beam M		1				W623718G01		
320	R63 E67 125	G	Beam M			1	1	1	W623718G03		
321	R63 N78 118	G	Fan guard		2	2	2	2	W126832G02		
322	R63 A42 659	G	Panel support		2				W615888H18		
323	R63 A43 659	G	Panel support			2	2	2	W615888G09		
324	R61 A69 086	G	Cap		2	2	2	2	P221056X01		
325	R63 A42 140	G	Fan stand		4				W856127G05		
326	R63 A43 140	G	Fan stand			4	4	4	W856127G06		
327	R63 A42 122	G	Nut 16		2	2	2	2	P541016X01		
328	R63 N78 115	G	Propeller fan	750D	2	2	2	2	W126814G01		
329	R63 Y43 221	G	Motor YC380IA	342V 33Hz	2	2	2	2	P714969X01		
330	R63 E90 087	G	Screw 6x14		8	8	8	8	P521020X01		
331	R63 Y09 482	G	Heat exchanger F						W656448G28		
332	R63 R54 480	G	Heat exchanger F			2			W656448G21		
333	R63 Y09 482	G	Heat exchanger F						W656448G28		
334	R63 Y03 482	G	Heat exchanger F				2		W656448G22		
335	R63 Y09 482	G	Heat exchanger F						W656448G28		
336	R63 R54 480	G	Heat exchanger F					2	W656448G21		
337	R63 Y09 482	G	Heat exchanger F						W656448G28		
338	R63 R54 480	G	Heat exchanger F						W656448G21		
339	R63 Y09 482	G	Heat exchanger F		2				W656448G28		
340	R63 R54 480	G	Heat exchanger F						W656448G21		
341	R63 Y16 482	G	Heat exchanger B						W656450G28		
342	R63 R54 481	G	Heat exchanger B			2			W656450G21		
343	R63 Y16 482	G	Heat exchanger B						W656450G28		
344	R63 R54 481	G	Heat exchanger B				2		W656450G21		
345	R63 Y16 482	G	Heat exchanger B						W656450G28		

PUHY-P450, P500YGM-A(-BS)
 PUHY-P550, P600YGM-A(-BS)
 PUHY-P650YGM-A(-BS)

EXTERNAL PARTS & BLOWER PARTS (3)

No.	Part No.	G : RoHS Apply Only W : RoHS Apply by Running Change		Spec.	PUHY-P60YGM-A	PUHY-P450YGM-A-BS	PUHY-P500YGM-A-BS	PUHY-P550YGM-A-BS	Dwg. No.	Price	Revision History
			Part Name								
346	R63 R54 481	G	Heat exchanger B					2	W656450G21		
347	R63 Y16 482	G	Heat exchanger B						W656450G28		C
348	R63 R54 481	G	Heat exchanger B						W656450G21		
349	R63 Y16 482	G	Heat exchanger B		2				W656450G28		
350	R63 R54 481	G	Heat exchanger B						W656450G21		
351	R63 Y68 305	G	Control box	P650YGM	1	1	1	1	KE00C068G12		

PUHY-P450, P500YGM-A(-BS)
 PUHY-P550, P600YGM-A(-BS)
 PUHY-P650YGM-A(-BS)

EXTERNAL PARTS & BLOWER PARTS (3)

No.	Part No.	G : RoHS Apply Only W : RoHS Apply by Running Change		Spec.	PUHY-P600YGM-A-BS	PUHY-P650YGM-A-BS		Dwg. No.	Price	Revision History
			Part Name							
301	R63 E66 611	G	Guard F assy		2	2		W265788G01		
302	R63 A42 638	G	Guard B assy		2	2		W265789G01		
303	R63 R34 667	G	Partition board L assy					W656425G01		
304	R63 R35 667	G	Partition board L assy		2	2		W656425G02		
305	R63 R43 668	G	Partition board R assy					W656424G03		
306	R63 R44 668	G	Partition board R assy		1	1		W656424G04		
307	R63 R43 667	G	Partition board R assy					W656424G05		
308	R63 R44 667	G	Partition board R assy		1	1		W656424G06		
309	R63 R43 626	G	Stay M					W656007G05		C
310	R63 R44 626	G	Stay M		2	2		W656007G02		
311	R63 R34 651	G	Panel F					W655252H01		
312	R63 R36 651	G	Panel F		2	2		W655252G02		
313	R63 Y32 652	G	Panel B					W655227H02		
314	R63 R36 677	G	Panel B		2	2		W655227G04		
315	R63 L78 653	G	Panel FU					W633746H06		
316	R63 R36 652	G	Panel FU		4	4		W633746G07		
317	R63 N78 661	G	Panel S					W272421H01		
318	R63 R36 661	G	Panel S		2	2		W272421G03		
319	R63 E66 125	G	Beam M					W623718G01		
320	R63 E67 125	G	Beam M		1	1		W623718G03		
321	R63 N78 118	G	Fan guard		2	2		W126832G02		
322	R63 A42 659	G	Panel support					W615888H18		
323	R63 A43 659	G	Panel support		2	2		W615888G09		
324	R61 A69 086	G	Cap		2	2		P221056X01		
325	R63 A42 140	G	Fan stand					W856127G05		
326	R63 A43 140	G	Fan stand		4	4		W856127G06		
327	R63 A42 122	G	Nut 16		2	2		P541016X01		
328	R63 N78 115	G	Propeller fan	750D	2	2		W126814G01		
329	R63 Y43 221	G	Motor YC380IA	342V 33Hz	2	2		P714969X01		
330	R63 E90 087	G	Screw 6x14		8	8		P521020X01		
331	R63 Y09 482	G	Heat exchanger F					W656448G28		
332	R63 R54 480	G	Heat exchanger F					W656448G21		
333	R63 Y09 482	G	Heat exchanger F					W656448G28		
334	R63 Y03 482	G	Heat exchanger F					W656448G22		
335	R63 Y09 482	G	Heat exchanger F					W656448G28		
336	R63 R54 480	G	Heat exchanger F					W656448G21		
337	R63 Y09 482	G	Heat exchanger F					W656448G28		
338	R63 R54 480	G	Heat exchanger F		2			W656448G21		
339	R63 Y09 482	G	Heat exchanger F					W656448G28		
340	R63 R54 480	G	Heat exchanger F			2		W656448G21		
341	R63 Y16 482	G	Heat exchanger B					W656450G28		
342	R63 R54 481	G	Heat exchanger B					W656450G21		
343	R63 Y16 482	G	Heat exchanger B					W656450G28		
344	R63 R54 481	G	Heat exchanger B					W656450G21		
345	R63 Y16 482	G	Heat exchanger B					W656450G28		

PUHY-P450, P500YGM-A(-BS)
 PUHY-P550, P600YGM-A(-BS)
 PUHY-P650YGM-A(-BS)

EXTERNAL PARTS & BLOWER PARTS (3)

No.	Part No.	G : RoHS Apply Only W : RoHS Apply by Running Change		Spec.	PUHY-P600YGM-A(-BS)	PUHY-P650YGM-A(-BS)		Dwg. No.	Price	Revision History
			Part Name							
346	R63 R54 481	G	Heat exchanger B					W656450G21		
347	R63 Y16 482	G	Heat exchanger B					W656450G28		C
348	R63 R54 481	G	Heat exchanger B		2			W656450G21		
349	R63 Y16 482	G	Heat exchanger B					W656450G28		
350	R63 R54 481	G	Heat exchanger B			2		W656450G21		
351	R63 Y68 305	G	Control box	P650YGM	1	1		KE00C068G12		

PU(H)Y-P200, P250YGM-A(-BS)
 PU(H)Y-P300, P350YGM-A(-BS)

FUNCTIONAL PARTS (1)

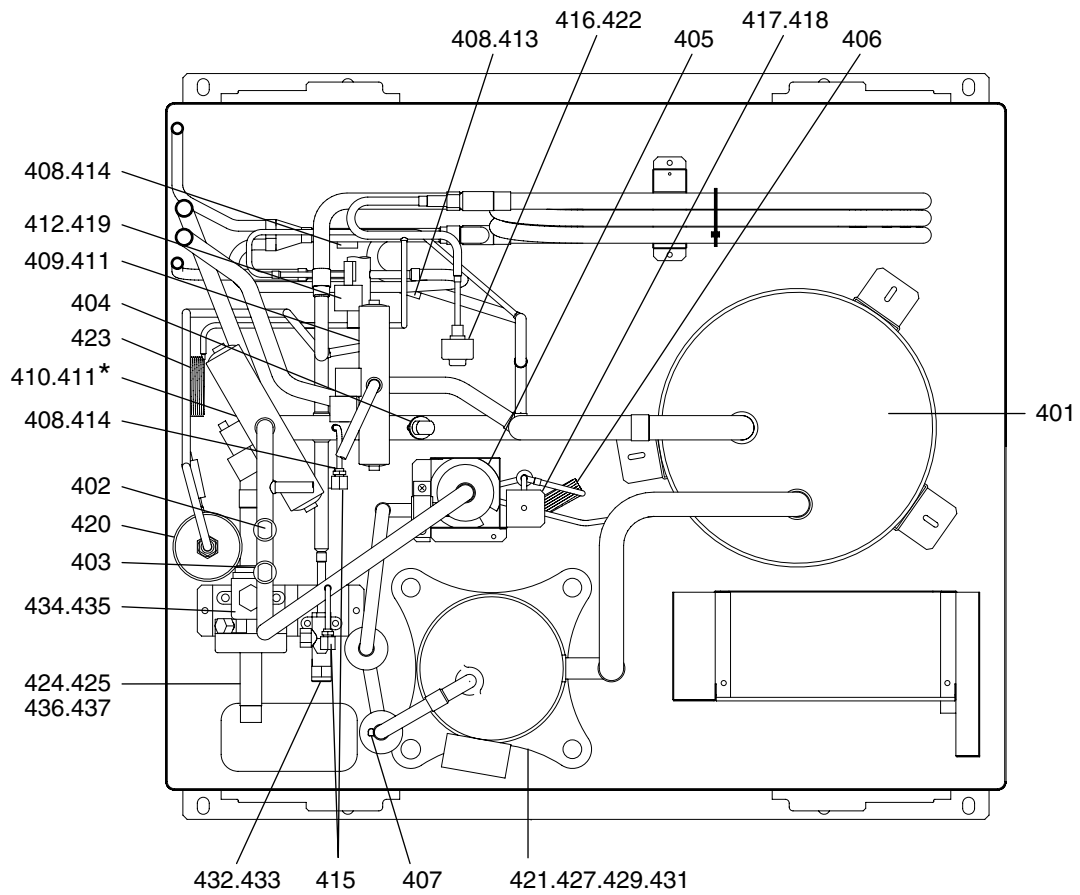

*411 : PUHY only.

PU(H)Y-P200

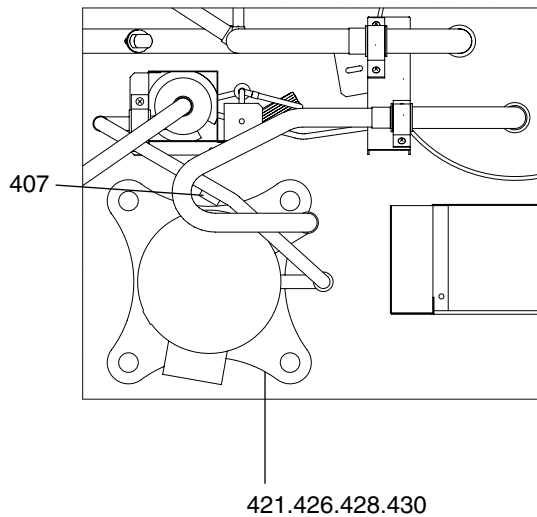

No.	Part No.	G : RoHS Apply Only W : RoHS Apply by Running Change		Spec.	PUY200YGM-A	PUY250YGM-A	PUY300YGM-A	PUY350YGM-A	Dwg. No.	Price	Revision History
			Part Name								
401	R63 Y53 484	G	Accumulator assy		1	1	1	1	W274166G09		
402	R63 Y11 208	G	Pressure switch	ACB1UB28W <63H>	1	1	1	1	P426320X01		
403	R63 R34 288	G	Pressure sensor R410A	<63HS>	1	1	1	1	P418015X01		
404	R63 R37 288	G	Pressure sensor R410A	<63LS>	1	1	1	1	P418014X01		
405	R63 R34 487	G	Oil separator assy		1	1	1	1	W656027G01		
406	R63 R34 425	G	Capillary tube assy		1	1	1	1	W905625G02		
407	R63 911 202	G	Thermistor	<TH11>	1	1	1	1	P425416X02		
408	R63 670 202	G	Thermistor NTH3A14	<TH5~8>	4	4	4	4	P425496X01		
409	R63 R55 154	G	Four way valve STF-04	R410A	1	1	1	1	P633118X01		
410	R63 Y05 154	G	Four way valve STF-07	R410A	1	1	1	1	P633119X01		
411	R63 Y16 243	G	Solenoid valve coil STF DV	<21S4a,21S4b>	1	1	1	1	P472024X01		
412	R63 002 242	G	Two way valve coil	<SV5b>	1	1	1	1	W875295G05		C
413	R61 A45 287	G	Sensor cover	EVA(12.7D)	1	1	1	1	P227171X01		
414	R61 A43 287	G	Sensor cover	EVA(16D)	2	2	2	2	P227172X01		
415	R63 R34 413	G	Check joint L R410A	VCSH2S-LM	2	2	2	2	P666001X01		
416	R63 R34 243	G	Solenoid valve coil	CAM 6P <LEV1>	1	1	1	1	P472008X02		C
417	R61 009 243	G	Solenoid valve coil	<SV1>	1	1	1	1	W875295G08		C
418	R61 024 232	G	Solenoid valve		1	1	1	1	KB00H253G03		C
419	R63 025 232	G	Two way valve		1	1	1	1	KB00H435G02		C
420	R63 M57 405	G	Drier	DML163/4	1	1	1	1	P641114X01		
421	R61 Y08 262	G	Belt heater	<CH11>	1	1	1	1	P493642X02		
422	R63 R34 401	G	Linear expansion valve	CAM35 R410A	1	1	1	1	P632416X01		
423	R63 L85 425	G	Capillary tube assy		1	1	1	1	W888053G01		
424	R63 9F2 441	G	Pipe assy	ID22.2		1	1		W663334G02		
425	R63 9F2 442	G	Pipe assy	ID28.6				1	W663334G04		
426	R66 A23 478	G	Compressor	(ANV47FFBMT)<MC>	1				W650609G04		
427	R66 A44 478	G	Scroll compressor	(HNB71FA-YBE)<MC>		1	1	1	EP10092G07		
428	R63 R34 580	G	Insulation cover	Body	1				W656008G02		
429	R63 R37 580	G	Insulation cover	Body		1	1	1	W654314G02		
430	R63 R40 580	G	Insulation cover	Head	1				W905175G02		
431	R63 R55 580	G	Insulation cover	Head		1	1	1	W903526G02		
432	R63 R37 410	G	Ball valve VSBH-3	R410A	1	1	1		P636305X01		
433	R63 R55 410	G	Ball valve VSBH-4	R410A				1	P636306X01		
434	R63 R34 410	G	Ball valve VSBH-6	R410A	1				P636308X01		
435	R63 R40 410	G	Ball valve VSMBH-8	R410A		1	1	1	P636309X02		
436	R61 F14 514	G	Packing			1	1	1	P321009X01		
437	R63 R34 494	G	Pipe assy		1				W905698G02		

No.	Part No.	G : RoHS Apply Only W : RoHS Apply by Running Change	Part Name	Spec.	PUY200YGM-A-BS	PUY250YGM-A-BS	PUY300YGM-A-BS	PUY350YGM-A-BS	Dwg. No.	Price	Revision History
401	R63 Y53 484	G	Accumulator assy		1	1	1	1	W274166G09		
402	R63 Y11 208	G	Pressure switch	ACB1UB28W <63H>	1	1	1	1	P426320X01		
403	R63 R34 288	G	Pressure sensor R410A	<63HS>	1	1	1	1	P418015X01		
404	R63 R37 288	G	Pressure sensor R410A	<63LS>	1	1	1	1	P418014X01		
405	R63 R34 487	G	Oil separator assy		1	1	1	1	W656027G01		
406	R63 R34 425	G	Capillary tube assy		1	1	1	1	W905625G02		
407	R63 911 202	G	Thermistor	<TH11>	1	1	1	1	P425416X02		
408	R63 670 202	G	Thermistor NTH3A14	<TH5~8>	4	4	4	4	P425496X01		
409	R63 R55 154	G	Four way valve STF-04	R410A	1	1	1	1	P633118X01		
410	R63 Y05 154	G	Four way valve STF-07	R410A	1	1	1	1	P633119X01		
411	R63 Y16 243	G	Solenoid valve coil STF DV	<21S4a,21S4b>	1	1	1	1	P472024X01		
412	R63 002 242	G	Two way valve coil	<SV5b>	1	1	1	1	W875295G05		C
413	R61 A45 287	G	Sensor cover	EVA(12.7D)	1	1	1	1	P227171X01		
414	R61 A43 287	G	Sensor cover	EVA(16D)	2	2	2	2	P227172X01		
415	R63 R34 413	G	Check joint L R410A	VCSH2S-LM	2	2	2	2	P666001X01		
416	R63 R34 243	G	Solenoid valve coil	CAM 6P <LEV1>	1	1	1	1	P472008X02		C
417	R61 009 243	G	Solenoid valve coil	<SV1>	1	1	1	1	W875295G08		C
418	R61 024 232	G	Solenoid valve		1	1	1	1	KB00H253G03		C
419	R63 025 232	G	Two way valve		1	1	1	1	KB00H435G02		C
420	R63 M57 405	G	Drier	DML163/4	1	1	1	1	P641114X01		
421	R61 Y08 262	G	Belt heater	<CH11>	1	1	1	1	P493642X02		
422	R63 R34 401	G	Linear expansion valve	CAM35 R410A	1	1	1	1	P632416X01		
423	R63 L85 425	G	Capillary tube assy		1	1	1	1	W888053G01		
424	R63 9F2 441	G	Pipe assy	ID22.2		1	1		W663334G02		
425	R63 9F2 442	G	Pipe assy	ID28.6				1	W663334G04		
426	R66 A23 478	G	Compressor	(ANV47FFBMT)<MC>	1				W650609G04		
427	R66 A44 478	G	Scroll compressor	(HNB71FA-YBE)<MC>		1	1	1	EP10092G07		
428	R63 R34 580	G	Insulation cover	Body	1				W656008G02		
429	R63 R37 580	G	Insulation cover	Body		1	1	1	W654314G02		
430	R63 R40 580	G	Insulation cover	Head	1				W905175G02		
431	R63 R55 580	G	Insulation cover	Head		1	1	1	W903526G02		
432	R63 R37 410	G	Ball valve VSBH-3	R410A	1	1	1		P636305X01		
433	R63 R55 410	G	Ball valve VSBH-4	R410A				1	P636306X01		
434	R63 R34 410	G	Ball valve VSBH-6	R410A	1				P636308X01		
435	R63 R40 410	G	Ball valve VSMBH-8	R410A		1	1	1	P636309X02		
436	R61 F14 514	G	Packing			1	1	1	P321009X01		
437	R63 R34 494	G	Pipe assy		1				W905698G02		

No.	Part No.	G : RoHS Apply Only W : RoHS Apply by Running Change		Spec.	PUHY-P200YGM-A	PUHY-P250YGM-A	PUHY-P300YGM-A	PUHY-P350YGM-A	Dwg. No.	Price	Revision History
			Part Name								
401	R63 Y53 484	G	Accumulator assy		1	1	1	1	W274166G09		
402	R63 Y11 208	G	Pressure switch	ACB1UB28W <63H>	1	1	1	1	P426320X01		
403	R63 R34 288	G	Pressure sensor R410A	<63HS>	1	1	1	1	P418015X01		
404	R63 R37 288	G	Pressure sensor R410A	<63LS>	1	1	1	1	P418014X01		
405	R63 R34 487	G	Oil separator assy		1	1	1	1	W656027G01		
406	R63 R34 425	G	Capillary tube assy		1	1	1	1	W905625G02		
407	R63 911 202	G	Thermistor	<TH11>	1	1	1	1	P425416X02		
408	R63 670 202	G	Thermistor NTH3A14	<TH5~8>	4	4	4	4	P425496X01		
409	R63 R55 154	G	Four way valve STF-04	R410A	1	1	1	1	P633118X01		
410	R63 Y05 154	G	Four way valve STF-07	R410A	1	1	1	1	P633119X01		
411	R63 Y16 243	G	Solenoid valve coil STF DV	<21S4a,21S4b>	2	2	2	2	P472024X01		
412	R63 002 242	G	Two way valve coil	<SV5b>	1	1	1	1	W875295G05		C
413	R61 A45 287	G	Sensor cover	EVA(12.7D)	1	1	1	1	P227171X01		
414	R61 A43 287	G	Sensor cover	EVA(16D)	2	2	2	2	P227172X01		
415	R63 R34 413	G	Check joint L R410A	VCSH2S-LM	2	2	2	2	P666001X01		
416	R63 R34 243	G	Solenoid valve coil	CAM 6P <LEV1>	1	1	1	1	P472008X02		C
417	R61 009 243	G	Solenoid valve coil	<SV1>	1	1	1	1	W875295G08		C
418	R61 024 232	G	Solenoid valve		1	1	1	1	KB00H253G03		C
419	R63 025 232	G	Two way valve		1	1	1	1	KB00H435G02		C
420	R63 M57 405	G	Drier	DML163/4	1	1	1	1	P641114X01		
421	R61 Y08 262	G	Belt heater	<CH11>	1	1	1	1	P493642X02		
422	R63 R34 401	G	Linear expansion valve	CAM35 R410A	1	1	1	1	P632416X01		
423	R63 L85 425	G	Capillary tube assy		1	1	1	1	W888053G01		
424	R63 9F2 441	G	Pipe assy	ID22.2		1	1		W663334G02		
425	R63 9F2 442	G	Pipe assy	ID28.6				1	W663334G04		
426	R66 A23 478	G	Compressor	(ANV47FFBMT)<MC>	1				W650609G04		
427	R66 A44 478	G	Scroll compressor	(HNB71FA-YBE)<MC>		1	1	1	EP10092G07		
428	R63 R34 580	G	Insulation cover	Body	1				W656008G02		
429	R63 R37 580	G	Insulation cover	Body		1	1	1	W654314G02		
430	R63 R40 580	G	Insulation cover	Head	1				W905175G02		
431	R63 R55 580	G	Insulation cover	Head		1	1	1	W903526G02		
432	R63 R37 410	G	Ball valve VSBH-3	R410A	1	1	1		P636305X01		
433	R63 R55 410	G	Ball valve VSBH-4	R410A				1	P636306X01		
434	R63 R34 410	G	Ball valve VSBH-6	R410A	1				P636308X01		
435	R63 R40 410	G	Ball valve VSMBH-8	R410A		1	1	1	P636309X02		
436	R61 F14 514	G	Packing			1	1	1	P321009X01		
437	R63 R34 494	G	Pipe assy		1				W905698G02		

No.	Part No.	G : RoHS Apply Only W : RoHS Apply by Running Change	Part Name	Spec.	PUHYP200YGM-A-BS	PUHYP250YGM-A-BS	PUHYP300YGM-A-BS	PUHYP350YGM-A-BS	Dwg. No.	Price	Revision History
401	R63 Y53 484	G	Accumulator assy		1	1	1	1	W274166G09		
402	R63 Y11 208	G	Pressure switch	ACB1UB28W <63H>	1	1	1	1	P426320X01		
403	R63 R34 288	G	Pressure sensor R410A	<63HS>	1	1	1	1	P418015X01		
404	R63 R37 288	G	Pressure sensor R410A	<63LS>	1	1	1	1	P418014X01		
405	R63 R34 487	G	Oil separator assy		1	1	1	1	W656027G01		
406	R63 R34 425	G	Capillary tube assy		1	1	1	1	W905625G02		
407	R63 911 202	G	Thermistor	<TH11>	1	1	1	1	P425416X02		
408	R63 670 202	G	Thermistor NTH3A14	<TH5~8>	4	4	4	4	P425496X01		
409	R63 R55 154	G	Four way valve STF-04	R410A	1	1	1	1	P633118X01		
410	R63 Y05 154	G	Four way valve STF-07	R410A	1	1	1	1	P633119X01		
411	R63 Y16 243	G	Solenoid valve coil STF DV	<21S4a,21S4b>	2	2	2	2	P472024X01		
412	R63 002 242	G	Two way valve coil	<SV5b>	1	1	1	1	W875295G05		C
413	R61 A45 287	G	Sensor cover	EVA(12.7D)	1	1	1	1	P227171X01		
414	R61 A43 287	G	Sensor cover	EVA(16D)	2	2	2	2	P227172X01		
415	R63 R34 413	G	Check joint L R410A	VCSH2S-LM	2	2	2	2	P666001X01		
416	R63 R34 243	G	Solenoid valve coil	CAM 6P <LEV1>	1	1	1	1	P472008X02		C
417	R61 009 243	G	Solenoid valve coil	<SV1>	1	1	1	1	W875295G08		C
418	R61 024 232	G	Solenoid valve		1	1	1	1	KB00H253G03		C
419	R63 025 232	G	Two way valve		1	1	1	1	KB00H435G02		C
420	R63 M57 405	G	Drier	DML163/4	1	1	1	1	P641114X01		
421	R61 Y08 262	G	Belt heater	<CH11>	1	1	1	1	P493642X02		
422	R63 R34 401	G	Linear expansion valve	CAM35 R410A	1	1	1	1	P632416X01		
423	R63 L85 425	G	Capillary tube assy		1	1	1	1	W888053G01		
424	R63 9F2 441	G	Pipe assy	ID22.2		1	1		W663334G02		
425	R63 9F2 442	G	Pipe assy	ID28.6				1	W663334G04		
426	R66 A23 478	G	Compressor	(ANV47FFBMT)<MC>	1				W650609G04		
427	R66 A44 478	G	Scroll compressor	(HNB71FA-YBE)<MC>		1	1	1	EP10092G07		
428	R63 R34 580	G	Insulation cover	Body	1				W656008G02		
429	R63 R37 580	G	Insulation cover	Body		1	1	1	W654314G02		
430	R63 R40 580	G	Insulation cover	Head	1				W905175G02		
431	R63 R55 580	G	Insulation cover	Head		1	1	1	W903526G02		
432	R63 R37 410	G	Ball valve VSBH-3	R410A	1	1	1		P636305X01		
433	R63 R55 410	G	Ball valve VSBH-4	R410A				1	P636306X01		
434	R63 R34 410	G	Ball valve VSBH-6	R410A	1				P636308X01		
435	R63 R40 410	G	Ball valve VSMBH-8	R410A		1	1	1	P636309X02		
436	R61 F14 514	G	Packing			1	1	1	P321009X01		
437	R63 R34 494	G	Pipe assy		1				W905698G02		

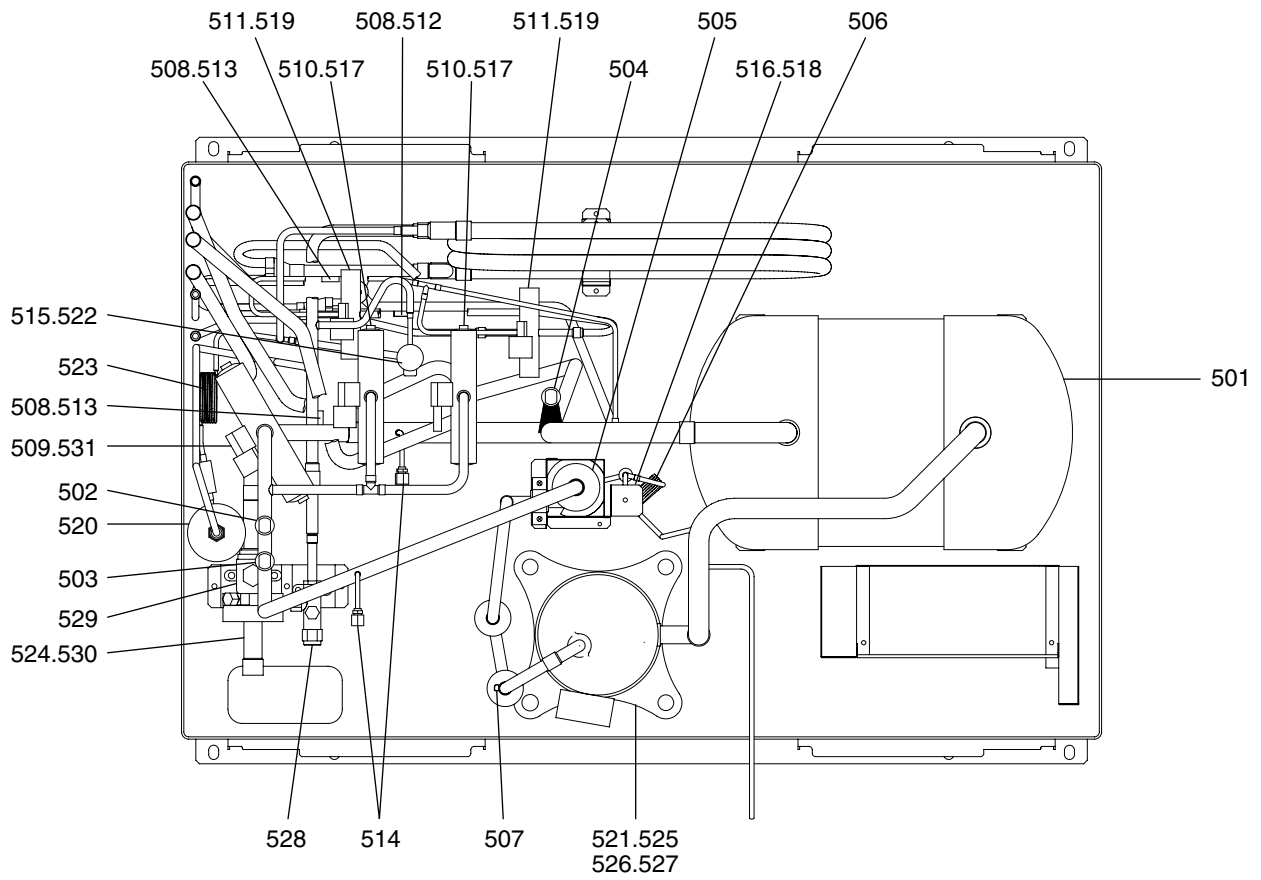

No.	Part No.	G : RoHS Apply Only W : RoHS Apply by Running Change	Part Name	Spec.	PUHYP400YGMA	PUHYP400YGMA-BS	Dwg. No.	Price	Revision History
501	R63 Y54 484	G	Accumulator assy		1	1	W274190G04		
502	R63 Y11 208	G	Pressure switch	ACB1UB28W <63H1>	1	1	P426320X01		
503	R63 R34 288	G	Pressure sensor R410A	<63HS>	1	1	P418015X01		
504	R63 R37 288	G	Pressure sensor R410A	<63LS>	1	1	P418014X01		
505	R63 R55 487	G	Oil separator assy		1	1	W656026G01		
506	R63 R55 425	G	Capillary tube assy		1	1	W905191G02		
507	R63 911 202	G	Thermistor	<TH11>	1	1	P425416X02		
508	R63 670 202	G	Thermistor NTH3A14	<TH5~8>	4	4	P425496X01		
509	R63 Y05 154	G	Four way valve STF-07	R410A	1	1	P633119X01		
510	R63 R55 154	G	Four way valve STF-04	R410A	2	2	P633118X01		
511	R63 002 242	G	Two way valve coil	<SV5b,SV5c>	2	2	W875295G05		C
512	R61 A45 287	G	Sensor cover	EVA(12.7D)	1	1	P227171X01		
513	R61 A43 287	G	Sensor cover	EVA(16D)	2	2	P227172X01		
514	R63 R34 413	G	Check joint L R410A	VCSH2S-LM	2	2	P666001X01		
515	R63 R34 243	G	Solenoid valve coil	CAM 6P <LEV1>	1	1	P472008X02		C
516	R61 009 243	G	Solenoid valve coil	<SV1>	1	1	W875295G08		C
517	R63 Y16 243	G	Solenoid valve coil VHV	<21S4b,21S4c>	2	2	P472024X01		
518	R61 024 232	G	Solenoid valve		1	1	KB00H253G03		C
519	R63 025 232	G	Two way valve		2	2	KB00H435G02		C
520	R63 M57 405	G	Drier	DML163/4	1	1	P641114X01		
521	R61 Y08 262	G	Belt heater	<CH11>	1	1	P493642X02		
522	R63 R34 401	G	Linear expansion valve	CAM35 R410A	1	1	P632416X01		
523	R63 L85 425	G	Capillary tube assy		1	1	W888053G01		
524	R63 9F2 442	G	Pipe assy	ID28.6	1	1	W663334G04		
525	R66 A44 478	G	Scroll compressor	(HNB71FA-YBE)<MC>	1	1	EP10092G07		
526	R63 R37 580	G	Insulation cover	Body	1	1	W654314G02		
527	R63 R55 580	G	Insulation cover	Head	1	1	W903526G02		
528	R63 R55 410	G	Ball valve VSBH-4	R410A	1	1	P636306X01		
529	R63 R40 410	G	Ball valve VSMBH-8	R410A	1	1	P636309X02		
530	R61 F14 514	G	Packing		1	1	P321009X01		
531	R63 Y07 242	G	Four way valve coil	<21S4a>	1	1	W875295G03		

PUHY-P450, P500YGM-A(-BS)
PUHY-P550, P600YGM-A(-BS)
PUHY-P650YGM-A(-BS)

FUNCTIONAL PARTS (3)

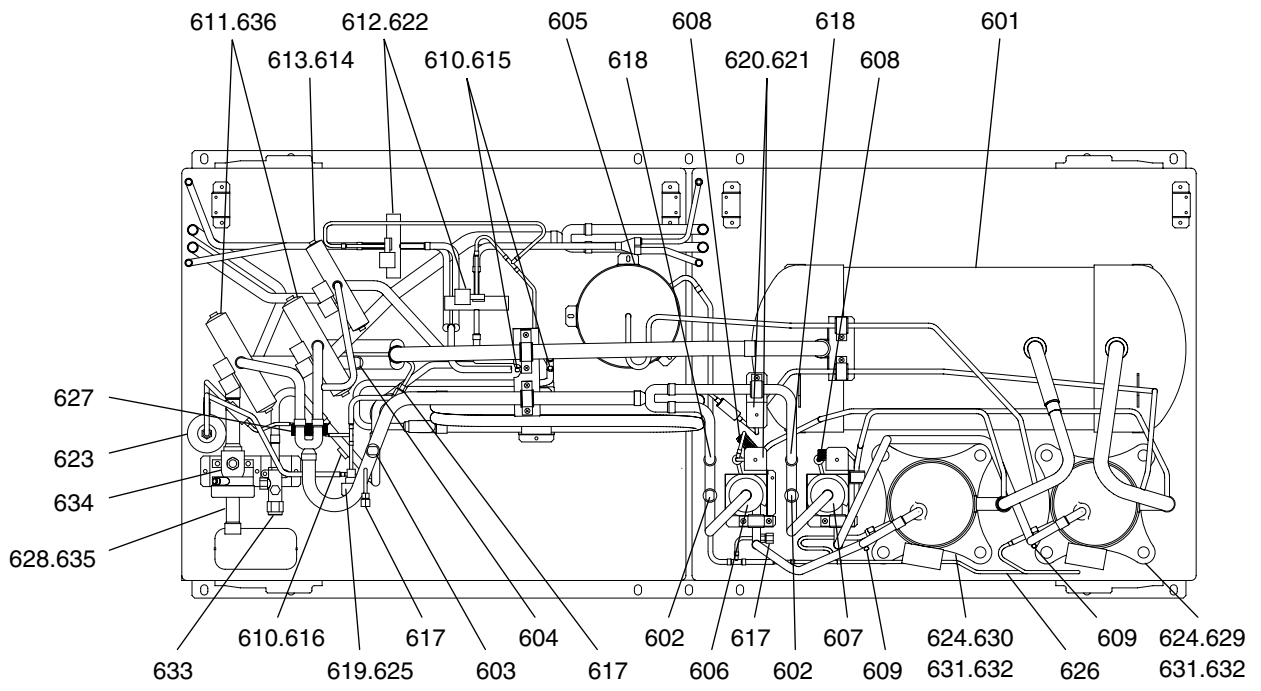

PUHY-P450, P500YGM-A(-BS)
 PUHY-P550, P600YGM-A(-BS)
 PUHY-P650YGM-A(-BS)

FUNCTIONAL PARTS (3)

No.	Part No.	G : RoHS Apply Only W : RoHS Apply by Running Change		Spec.	PUHY-P450YGM-A	PUHY-P500YGM-A	PUHY-P550YGM-A	PUHY-P600YGM-A	Dwg. No.	Price	Revision History
			Part Name								
601	R63 Y05 110	G	Accumulator assy		1	1	1	1	W274189G05		
602	R63 Y11 208	G	Pressure switch	ACB1UB28W <63H1,2>	2	2	2	2	P426320X01		
603	R63 R34 288	G	Pressure sensor R410A	<63HS>	1	1	1	1	P418015X01		
604	R63 R37 288	G	Pressure sensor R410A	<63LS>	1	1	1	1	P418014X01		
605	R63 Y03 530	G	Oil tank		1	1	1	1	W655257G07		
606	R63 R44 487	G	Oil separator assy1	<O/S1>	1	1	1	1	W656073G02		
607	R63 R43 487	G	Oil separator assy2	<O/S2>	1	1	1	1	W656074G01		
608	R63 R55 425	G	Capillary tube assy		2	2	2	2	W905191G02		
609	R63 911 202	G	Thermistor	<TH11,12>	2	2	2	2	P425416X02		
610	R63 670 202	G	Thermistor NTH3A14	<TH5~8>	4	4	4	4	P425496X01		
611	R63 Y05 154	G	Four way valve VT6100M	R410A	2	2	2	2	P633119X01		
612	R63 002 242	G	Two way valve coil	<SV5b,SV5c>	2	2	2	2	W875295G05		C
613	R63 R55 154	G	Four way valve STF-04	R410A	1	1	1	1	P633118X01		
614	R63 Y16 243	G	Solenoid valve coil STF DV	<21S4c>	1	1	1	1	P472024X01		
615	R61 A45 287	G	Sensor cover	EVA(12.7D)	2	2	2	2	P227171X01		
616	R61 A43 287	G	Sensor cover	EVA(16D)	1	1	1	1	P227172X01		
617	R63 R34 413	G	Check joint L R410A	VCSH2S-LM	3	3	3	3	P666001X01		
618	R63 R43 418	G	Check valve BCV-1005DY	R410A 4.15MPa CV3.5	2	2	2	2	P639165X01		
619	R63 R34 243	G	Solenoid valve coil	CAM 6P<LEV1>	1	1	1	1	P472008X02		C
620	R61 009 243	G	Solenoid valve coil	<SV1,3>	2	2	2	2	W875295G08		C
621	R61 024 232	G	Solenoid valve		2	2	2	2	KB00H253G03		C
622	R63 025 232	G	Two way valve		2	2	2	2	KB00H435G02		C
623	R63 N24 405	G	Drier	DML303/4	1	1	1	1	P641115X01		
624	R63 Y07 237	G	Belt heater	<CH11,12>	2	2	2	2	P493781X02		C
625	R63 R34 401	G	Linear expansion valve	CAM35 R410A	1	1	1	1	P632416X01		
626	R63 Y14 494	G	Pipe assy		1	1	1	1	W659300G03		
627	R63 L85 425	G	Capillary tube assy		1	1	1	1	W888053G01		
628	R63 9F2 442	G	Pipe assy	ID28.6	1	1	1	1	W663334G04		
629	R66 A25 478	G	Scroll compressor	(HN71YA-J)<MC2>	1	1	1	1	EP10093G02		
630	R66 A26 478	G	Scroll compressor	(HNB71FA-YJ)<MC1>	1	1	1	1	EP10092G04		
631	R63 R37 580	G	Insulation cover	Body	2	2	2	2	W654314G02		
632	R63 R55 580	G	Insulation cover	Head	2	2	2	2	W903526G02		
633	R63 R43 410	G	Ball valve VSBH-5	R410A	1	1	1	1	P636307X01		
634	R63 R40 410	G	Ball valve VSMBH-8	R410A	1	1	1	1	P636309X02		
635	R61 F14 514	G	Packing		1	1	1	1	P321009X01		
636	R63 Y07 242	G	Four way valve coil	<21S4a,21S4b>	2	2	2	2	W875295G03		

PUHY-P450, P500YGM-A(-BS)
 PUHY-P550, P600YGM-A(-BS)
 PUHY-P650YGM-A(-BS)

FUNCTIONAL PARTS (3)

No.	Part No.	G : RoHS Apply Only W : RoHS Apply by Running Change		Spec.	PUHY-P60YGM-A	PUHY-P450YGM-A-BS	PUHY-P500YGM-A-BS	PUHY-P550YGM-A-BS	Dwg. No.	Price	Revision History
			Part Name								
601	R63 Y05 110	G	Accumulator assy		1	1	1	1	W274189G05		
602	R63 Y11 208	G	Pressure switch	ACB1UB28W <63H1,2>	2	2	2	2	P426320X01		
603	R63 R34 288	G	Pressure sensor R410A	<63HS>	1	1	1	1	P418015X01		
604	R63 R37 288	G	Pressure sensor R410A	<63LS>	1	1	1	1	P418014X01		
605	R63 Y03 530	G	Oil tank		1	1	1	1	W655257G07		
606	R63 R44 487	G	Oil separator assy1	<O/S1>	1	1	1	1	W656073G02		
607	R63 R43 487	G	Oil separator assy2	<O/S2>	1	1	1	1	W656074G01		
608	R63 R55 425	G	Capillary tube assy		2	2	2	2	W905191G02		
609	R63 911 202	G	Thermistor	<TH11,12>	2	2	2	2	P425416X02		
610	R63 670 202	G	Thermistor NTH3A14	<TH5~8>	4	4	4	4	P425496X01		
611	R63 Y05 154	G	Four way valve VT6100M	R410A	2	2	2	2	P633119X01		
612	R63 002 242	G	Two way valve coil	<SV5b,SV5c>	2	2	2	2	W875295G05		C
613	R63 R55 154	G	Four way valve STF-04	R410A	1	1	1	1	P633118X01		
614	R63 Y16 243	G	Solenoid valve coil STF DV	<21S4c>	1	1	1	1	P472024X01		
615	R61 A45 287	G	Sensor cover	EVA(12.7D)	2	2	2	2	P227171X01		
616	R61 A43 287	G	Sensor cover	EVA(16D)	1	1	1	1	P227172X01		
617	R63 R34 413	G	Check joint L R410A	VCSH2S-LM	3	3	3	3	P666001X01		
618	R63 R43 418	G	Check valve BCV-1005DY	R410A 4.15MPa CV3.5	2	2	2	2	P639165X01		
619	R63 R34 243	G	Solenoid valve coil	CAM 6P<LEV1>	1	1	1	1	P472008X02		C
620	R61 009 243	G	Solenoid valve coil	<SV1,3>	2	2	2	2	W875295G08		C
621	R61 024 232	G	Solenoid valve		2	2	2	2	KB00H253G03		C
622	R63 025 232	G	Two way valve		2	2	2	2	KB00H435G02		C
623	R63 N24 405	G	Drier	DML303/4	1	1	1	1	P641115X01		
624	R63 Y07 237	G	Belt heater	<CH11,12>	2	2	2	2	P493781X02		C
625	R63 R34 401	G	Linear expansion valve	CAM35 R410A	1	1	1	1	P632416X01		
626	R63 Y14 494	G	Pipe assy		1	1	1	1	W659300G03		
627	R63 L85 425	G	Capillary tube assy		1	1	1	1	W888053G01		
628	R63 9F2 442	G	Pipe assy	ID28.6	1	1	1	1	W663334G04		
629	R66 A25 478	G	Scroll compressor	(HN71YA-J)<MC2>	1	1	1	1	EP10093G02		
630	R66 A26 478	G	Scroll compressor	(HNB71FA-YJ)<MC1>	1	1	1	1	EP10092G04		
631	R63 R37 580	G	Insulation cover	Body	2	2	2	2	W654314G02		
632	R63 R55 580	G	Insulation cover	Head	2	2	2	2	W903526G02		
633	R63 R43 410	G	Ball valve VSBH-5	R410A	1	1	1	1	P636307X01		
634	R63 R40 410	G	Ball valve VSMBH-8	R410A	1	1	1	1	P636309X02		
635	R61 F14 514	G	Packing		1	1	1	1	P321009X01		
636	R63 Y07 242	G	Four way valve coil	<21S4a,21S4b>	2	2	2	2	W875295G03		

No.	Part No.	G : RoHS Apply Only W : RoHS Apply by Running Change	Part Name	Spec.	PUHY-P600YGM-A-BS	PUHY-P650YGM-A-BS			Dwg. No.	Price	Revision History
601	R63 Y05 110	G	Accumulator assy		1	1			W274189G05		
602	R63 Y11 208	G	Pressure switch	ACB1UB28W <63H1,2>	2	2			P426320X01		
603	R63 R34 288	G	Pressure sensor R410A	<63HS>	1	1			P418015X01		
604	R63 R37 288	G	Pressure sensor R410A	<63LS>	1	1			P418014X01		
605	R63 Y03 530	G	Oil tank		1	1			W655257G07		
606	R63 R44 487	G	Oil separator assy1	<O/S1>	1	1			W656073G02		
607	R63 R43 487	G	Oil separator assy2	<O/S2>	1	1			W656074G01		
608	R63 R55 425	G	Capillary tube assy		2	2			W905191G02		
609	R63 911 202	G	Thermistor	<TH11,12>	2	2			P425416X02		
610	R63 670 202	G	Thermistor NTH3A14	<TH5~8>	4	4			P425496X01		
611	R63 Y05 154	G	Four way valve VT6100M	R410A	2	2			P633119X01		
612	R63 002 242	G	Two way valve coil	<SV5b,SV5c>	2	2			W875295G05		C
613	R63 R55 154	G	Four way valve STF-04	R410A	1	1			P633118X01		
614	R63 Y16 243	G	Solenoid valve coil STF DV	<21S4c>	1	1			P472024X01		
615	R61 A45 287	G	Sensor cover	EVA(12.7D)	2	2			P227171X01		
616	R61 A43 287	G	Sensor cover	EVA(16D)	1	1			P227172X01		
617	R63 R34 413	G	Check joint L R410A	VCSH2S-LM	3	3			P666001X01		
618	R63 R43 418	G	Check valve BCV-1005DY	R410A 4.15MPa CV3.5	2	2			P639165X01		
619	R63 R34 243	G	Solenoid valve coil	CAM 6P<LEV1>	1	1			P472008X02		C
620	R61 009 243	G	Solenoid valve coil	<SV1,3>	2	2			W875295G08		C
621	R61 024 232	G	Solenoid valve		2	2			KB00H253G03		C
622	R63 025 232	G	Two way valve		2	2			KB00H435G02		C
623	R63 N24 405	G	Drier	DML303/4	1	1			P641115X01		
624	R63 Y07 237	G	Belt heater	<CH11,12>	2	2			P493781X02		C
625	R63 R34 401	G	Linear expansion valve	CAM35 R410A	1	1			P632416X01		
626	R63 Y14 494	G	Pipe assy		1	1			W659300G03		
627	R63 L85 425	G	Capillary tube assy		1	1			W888053G01		
628	R63 9F2 442	G	Pipe assy	ID28.6	1	1			W663334G04		
629	R66 A25 478	G	Scroll compressor	(HN71YA-J)<MC2>	1	1			EP10093G02		
630	R66 A26 478	G	Scroll compressor	(HNB71FA-YJ)<MC1>	1	1			EP10092G04		
631	R63 R37 580	G	Insulation cover	Body	2	2			W654314G02		
632	R63 R55 580	G	Insulation cover	Head	2	2			W903526G02		
633	R63 R43 410	G	Ball valve VSBH-5	R410A	1	1			P636307X01		
634	R63 R40 410	G	Ball valve VSMBH-8	R410A	1	1			P636309X02		
635	R61 F14 514	G	Packing		1	1			P321009X01		
636	R63 Y07 242	G	Four way valve coil	<21S4a,21S4b>	2	2			W875295G03		

PU(H)Y-P200, P250YGM-A(-BS)
 PU(H)Y-P300, P350YGM-A(-BS)
 PUHY-P400YGM-A(-BS)

CONTROL BOX PARTS (1)

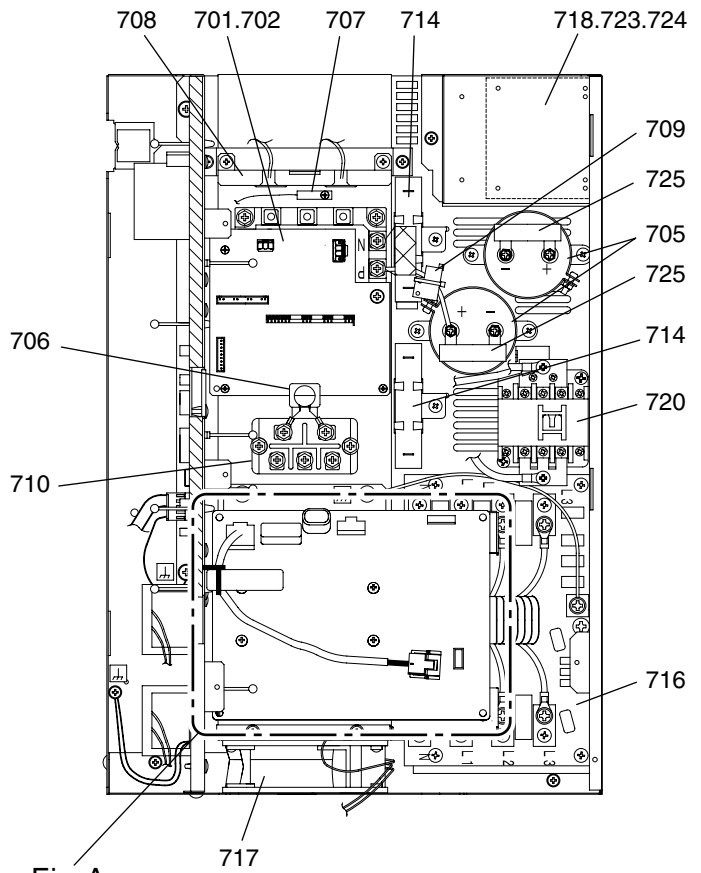
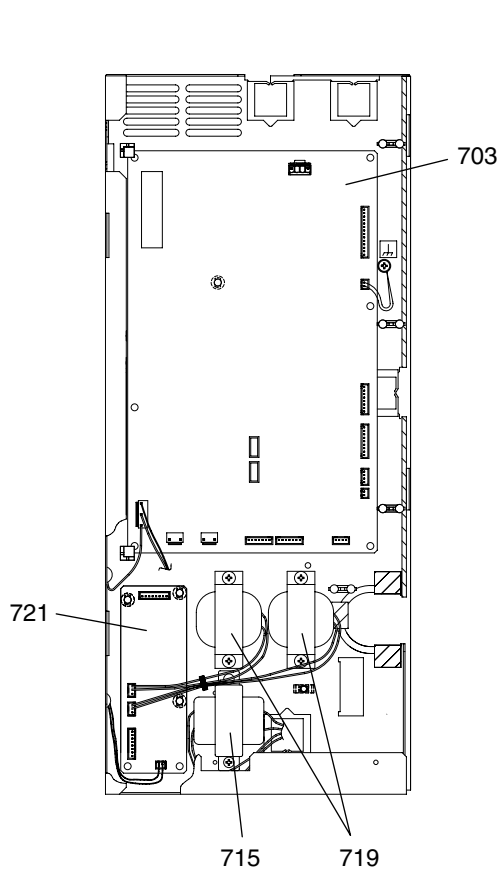
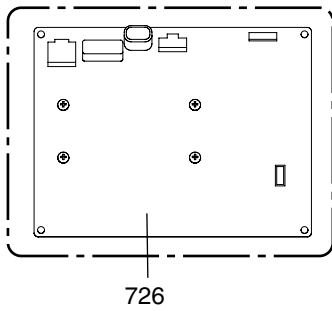

Fig.A

Fig.A

- Production number 5ZW**** and before



- Production number 51W**** and later (RoHS-compliant outdoor unit)

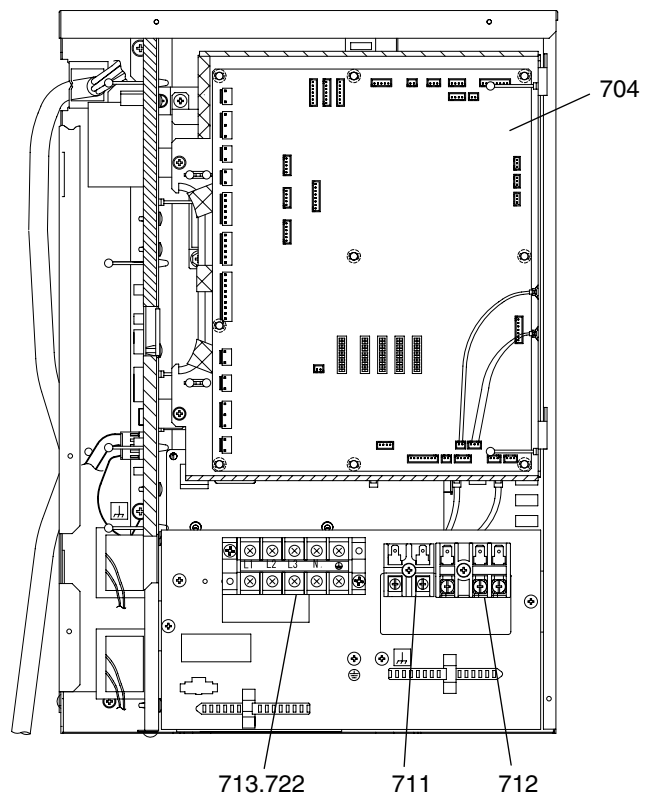
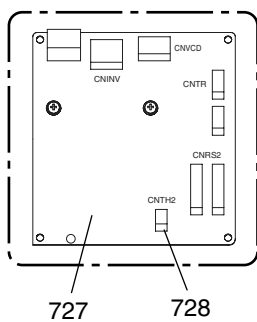

PU(H)Y-P200, P250YGM-A(-BS)
 PU(H)Y-P300, P350YGM-A(-BS)
 PUHY-P400YGM-A(-BS)

CONTROL BOX PARTS (1)

No.	Part No.	G : RoHS Apply Only W : RoHS Apply by Running Change		Spec.	PUY-P200YGM-A	PUY-P250YGM-A	PUY-P300YGM-A	PUY-P350YGM-A	Dwg. No.	Price	Revision History
		Part Name									
701	R63 Y04 249	G	IPM (Power module)	6MBP50RA120	1	1	1	1	W848413G10		
702	R63 Y43 280	G	G/A board		1	1	1	1	W652112G02		
703	R63 Y25 321	G	INV board		1	1	1	1	W647875G04		
704	R63 Y46 281	G	Main board		1	1	1	1	W647876G08		
705	R63 R34 252	G	Capacitor	400V 3300μF<C11,C12>	2	2	2	2	P412293X01		
706	R63 L85 252	G	Capacitor assy	<ZNR14>	1	1	1	1	W886345G01		
707	R63 F14 201	G	Thermistor	<THHS>	1	1	1	1	P414095X01		
708	R63 Y02 287	G	AC current sensor	CHJ038CP2B <AC-CT>	1	1	1	1	W652122G01		
709	R63 A42 289	G	DC current sensor	<DC-CT>		1	1	1	P419079X02		
710	R63 Y12 320	G	Diode	DF60LB160 <DS1>	1	1	1	1	W876941G06		
711	R61 008 246	G	Terminal block	<TB3>	1	1	1	1	BA73S950H02		C
712	R63 979 247	G	Terminal block	<TB7>	1	1	1	1	P436110X01		
713	R63 Y05 246	G	Terminal block	<TB1>	1	1	1	1	P436151X01		
714	R63 Y06 234	G	Resistor	40W, 47Ω <R11,R12>	2	2	2	2	P411141X01		
715	R63 Y25 260	G	Transformer	230V/20.1V<T01>	1	1	1	1	P715378X02		
716	R63 Y11 293	G	Noise filter	CF4032C-MX2 <ACNF1>	1	1	1	1	P417012X01		
717	R63 Y15 118	G	Fan	109S025UL<MF1>	1	1	1	1	W639916G01		
718	R63 Y02 259	G	Reactor	<DCL1>	1				P715427X01		C
719	R63 002 923	G	Choke coil	10mH 2A<L1,L2>	2	2	2	2	P715421X01		C
720	R63 Y28 225	G	Magnet contactor	PAK-21J,AC240V<52C1>	1	1	1	1	S427020H12		
721	R63 Y26 321	G	Filter board		1	1	1	1	W629574G06		
722	R63 Y06 246	G	Terminal block	<TB1>					P436213X01		
723	R61 008 259	G	Reactor	<DCL1>		1	1	1	P715428X01		C
724	R61 009 259	G	Reactor	<DCL1>					P715429X01		C
725	R63 Y04 234	G	Resistor	<R13,R14>	2	2	2	2	P411124X01		
★	726	R61 Y24 321	Fan INV board		1	1	1	1	W652171G02		
★	727	R63 Y74 281	G Fan INV board-A		1	1	1	1	W652171G05		
	728	R63 R49 200	G Thermistor	<THHS5>	1	1	1	1	W902268G01		

★ RoHS-compliant outdoor units (production number 51W***** and later) use Fan INV board No. 727.
 Fan INV boards No. 726 and No. 727 are not interchangeable.
 If RoHS-compliance status information of a given unit (production number) is not available, procure Fan INV boards No. 726 and No. 727.

PU(H)Y-P200, P250YGM-A(-BS)
 PU(H)Y-P300, P350YGM-A(-BS)
 PUHY-P400YGM-A(-BS)

CONTROL BOX PARTS (1)

No.	Part No.	G : RoHS Apply Only W : RoHS Apply by Running Change		Spec.	PUY200YGM-A-BS	PUY250YGM-A-BS	PUY300YGM-A-BS	PUY350YGM-A-BS	Dwg. No.	Price	Revision History
			Part Name								
701	R63 Y04 249	G	IPM (Power module)	6MBP50RA120	1	1	1	1	W848413G10		
702	R63 Y43 280	G	G/A board		1	1	1	1	W652112G02		
703	R63 Y25 321	G	INV board		1	1	1	1	W647875G04		
704	R63 Y46 281	G	Main board		1	1	1	1	W647876G08		
705	R63 R34 252	G	Capacitor	400V 3300μF<C11,C12>	2	2	2	2	P412293X01		
706	R63 L85 252	G	Capacitor assy	<ZNR14>	1	1	1	1	W886345G01		
707	R63 F14 201	G	Thermistor	<THHS>	1	1	1	1	P414095X01		
708	R63 Y02 287	G	AC current sensor	CHJ038CP2B <AC-CT>	1	1	1	1	W652122G01		
709	R63 A42 289	G	DC current sensor	<DC-CT>		1	1	1	P419079X02		
710	R63 Y12 320	G	Diode	DF60LB160 <DS1>	1	1	1	1	W876941G06		
711	R61 008 246	G	Terminal block	<TB3>	1	1	1	1	BA73S950H02		C
712	R63 979 247	G	Terminal block	<TB7>	1	1	1	1	P436110X01		
713	R63 Y05 246	G	Terminal block	<TB1>	1	1	1	1	P436151X01		
714	R63 Y06 234	G	Resistor	40W, 47Ω <R11,R12>	2	2	2	2	P411141X01		
715	R63 Y25 260	G	Transformer	230V/20.1V<T01>	1	1	1	1	P715378X02		
716	R63 Y11 293	G	Noise filter	CF4032C-MX2 <ACNF1>	1	1	1	1	P417012X01		
717	R63 Y15 118	G	Fan	109S025UL<MF1>	1	1	1	1	W639916G01		
718	R63 Y02 259	G	Reactor	<DCL1>	1				P715427X01		C
719	R63 002 923	G	Choke coil	10mH 2A<L1,L2>	2	2	2	2	P715421X01		C
720	R63 Y28 225	G	Magnet contactor	PAK-21J,AC240V<52C1>	1	1	1	1	S427020H12		
721	R63 Y26 321	G	Filter board		1	1	1	1	W629574G06		
722	R63 Y06 246	G	Terminal block	<TB1>					P436213X01		
723	R61 008 259	G	Reactor	<DCL1>		1	1	1	P715428X01		C
724	R61 009 259	G	Reactor	<DCL1>					P715429X01		C
725	R63 Y04 234	G	Resistor	<R13,R14>	2	2	2	2	P411124X01		
★	726	R61 Y24 321	Fan INV board		1	1	1	1	W652171G02		
★	727	R63 Y74 281	G Fan INV board-A		1	1	1	1	W652171G05		
	728	R63 R49 200	G Thermistor	<THHS5>	1	1	1	1	W902268G01		

★ RoHS-compliant outdoor units (production number 51W***** and later) use Fan INV board No. 727.
 Fan INV boards No. 726 and No. 727 are not interchangeable.
 If RoHS-compliance status information of a given unit (production number) is not available, procure Fan INV boards No. 726 and No. 727.

PU(H)Y-P200, P250YGM-A(-BS)
 PU(H)Y-P300, P350YGM-A(-BS)
 PUHY-P400YGM-A(-BS)

CONTROL BOX PARTS (1)

No.	Part No.	G : RoHS Apply Only W : RoHS Apply by Running Change	Part Name	Spec.	PUHY-P200YGM-A	PUHY-P250YGM-A	PUHY-P300YGM-A	PUHY-P350YGM-A	Dwg. No.	Price	Revision History
702	R63 Y43 280	G	G/A board		1	1	1	1	W652112G02		
703	R63 Y25 321	G	INV board		1	1	1	1	W647875G04		
704	R63 Y46 281	G	Main board		1	1	1	1	W647876G08		
705	R63 R34 252	G	Capacitor	400V 3300μF<C11,C12>	2	2	2	2	P412293X01		
706	R63 L85 252	G	Capacitor assy	<ZNR14>	1	1	1	1	W886345G01		
707	R63 F14 201	G	Thermistor	<THHS>	1	1	1	1	P414095X01		
708	R63 Y02 287	G	AC current sensor	CHJ038CP2B <AC-CT>	1	1	1	1	W652122G01		
709	R63 A42 289	G	DC current sensor	<DC-CT>		1	1	1	P419079X02		
710	R63 Y12 320	G	Diode	DF60LB160 <DS1>	1	1	1	1	W876941G06		
711	R61 008 246	G	Terminal block	<TB3>	1	1	1	1	BA73S950H02		C
712	R63 979 247	G	Terminal block	<TB7>	1	1	1	1	P436110X01		
713	R63 Y05 246	G	Terminal block	<TB1>	1	1	1	1	P436151X01		
714	R63 Y06 234	G	Resistor	40W, 47Ω <R11,R12>	2	2	2	2	P411141X01		
715	R63 Y25 260	G	Transformer	230V/20.1V<T01>	1	1	1	1	P715378X02		
716	R63 Y11 293	G	Noise filter	CF4032C-MX2 <ACNF1>	1	1	1	1	P417012X01		
717	R63 Y15 118	G	Fan	109S025UL<MF1>	1	1	1	1	W639916G01		
718	R63 Y02 259	G	Reactor	<DCL1>	1				P715427X01		C
719	R63 002 923	G	Choke coil	10mH 2A<L1,L2>	2	2	2	2	P715421X01		C
720	R63 Y28 225	G	Magnet contactor	PAK-21J,AC240V<52C1>	1	1	1	1	S427020H12		
721	R63 Y26 321	G	Filter board		1	1	1	1	W629574G06		
722	R63 Y06 246	G	Terminal block	<TB1>					P436213X01		
723	R61 008 259	G	Reactor	<DCL1>		1	1	1	P715428X01		C
724	R61 009 259	G	Reactor	<DCL1>					P715429X01		C
725	R63 Y04 234	G	Resistor	<R13,R14>	2	2	2	2	P411124X01		
★	R61 Y24 321		Fan INV board		1	1	1	1	W652171G02		
★	R63 Y74 281	G	Fan INV board-A		1	1	1	1	W652171G05		
	R63 R49 200	G	Thermistor	<THHS5>	1	1	1	1	W902268G01		
<p>★ RoHS-compliant outdoor units (production number 51W***** and later) use Fan INV board No. 727. Fan INV boards No. 726 and No. 727 are not interchangeable. If RoHS-compliance status information of a given unit (production number) is not available, procure Fan INV boards No. 726 and No. 727.</p>											

PU(H)Y-P200, P250YGM-A(-BS)
 PU(H)Y-P300, P350YGM-A(-BS)
 PUHY-P400YGM-A(-BS)

CONTROL BOX PARTS (1)

No.	Part No.	G : RoHS Apply Only W : RoHS Apply by Running Change		Spec.	PUHYP400YGM-A	PUHYP400YGM-A-BS	Dwg. No.	Price	Revision History
			Part Name						
701	R63 Y04 249	G	IPM (Power module)	6MBP50RA120	1	1	W848413G10		
702	R63 Y43 280	G	G/A board		1	1	W652112G02		
703	R63 Y25 321	G	INV board		1	1	W647875G04		
704	R63 Y46 281	G	Main board		1	1	W647876G08		
705	R63 R34 252	G	Capacitor	400V 3300μF<C11,C12>	2	2	P412293X01		
706	R63 L85 252	G	Capacitor assy	<ZNR14>	1	1	W886345G01		
707	R63 F14 201	G	Thermistor	<THHS>	1	1	P414095X01		
708	R63 Y02 287	G	AC current sensor	CHJ038CP2B <AC-CT>	1	1	W652122G01		
709	R63 A42 289	G	DC current sensor	<DC-CT>	1	1	P419079X02		
710	R63 Y12 320	G	Diode	DF60LB160 <DS1>	1	1	W876941G06		
711	R61 008 246	G	Terminal block	<TB3>	1	1	BA73S950H02		C
712	R63 979 247	G	Terminal block	<TB7>	1	1	P436110X01		
713	R63 Y05 246	G	Terminal block	<TB1>			P436151X01		
714	R63 Y06 234	G	Resistor	40W, 47Ω <R11,R12>	2	2	P411141X01		
715	R63 Y25 260	G	Transformer	230V/20.1V<T01>	1	1	P715378X02		
716	R63 Y11 293	G	Noise filter	CF4032C-MX2 <ACNF1>	1	1	P417012X01		
717	R63 Y15 118	G	Fan	109S025UL<MF1>	1	1	W639916G01		
718	R63 Y02 259	G	Reactor	<DCL1>			P715427X01		C
719	R63 002 923	G	Choke coil	10mH 2A<L1,L2>	2	2	P715421X01		C
720	R63 Y28 225	G	Magnet contactor	PAK-21J,AC240V<52C1>	1	1	S427020H12		
721	R63 Y26 321	G	Filter board		1	1	W629574G06		
722	R63 Y06 246	G	Terminal block	<TB1>	1	1	P436213X01		
723	R61 008 259	G	Reactor	<DCL1>			P715428X01		C
724	R61 009 259	G	Reactor	<DCL1>	1	1	P715429X01		C
725	R63 Y04 234	G	Resistor	<R13,R14>	2	2	P411124X01		
* 726	R61 Y24 321		Fan INV board		1	1	W652171G02		
* 727	R63 Y74 281	G	Fan INV board-A		1	1	W652171G05		
728	R63 R49 200	G	Thermistor	<THHS5>	1	1	W902268G01		

* RoHS-compliant outdoor units (production number 51W***** and later) use Fan INV board No. 727.
 Fan INV boards No. 726 and No. 727 are not interchangeable.
 If RoHS-compliance status information of a given unit (production number) is not available, procure Fan INV boards No. 726 and No. 727.

PUHY-P450, P500YGM-A(-BS)
 PUHY-P550, P600YGM-A(-BS)
 PUHY-P650YGM-A(-BS)

CONTROL BOX PARTS (2)

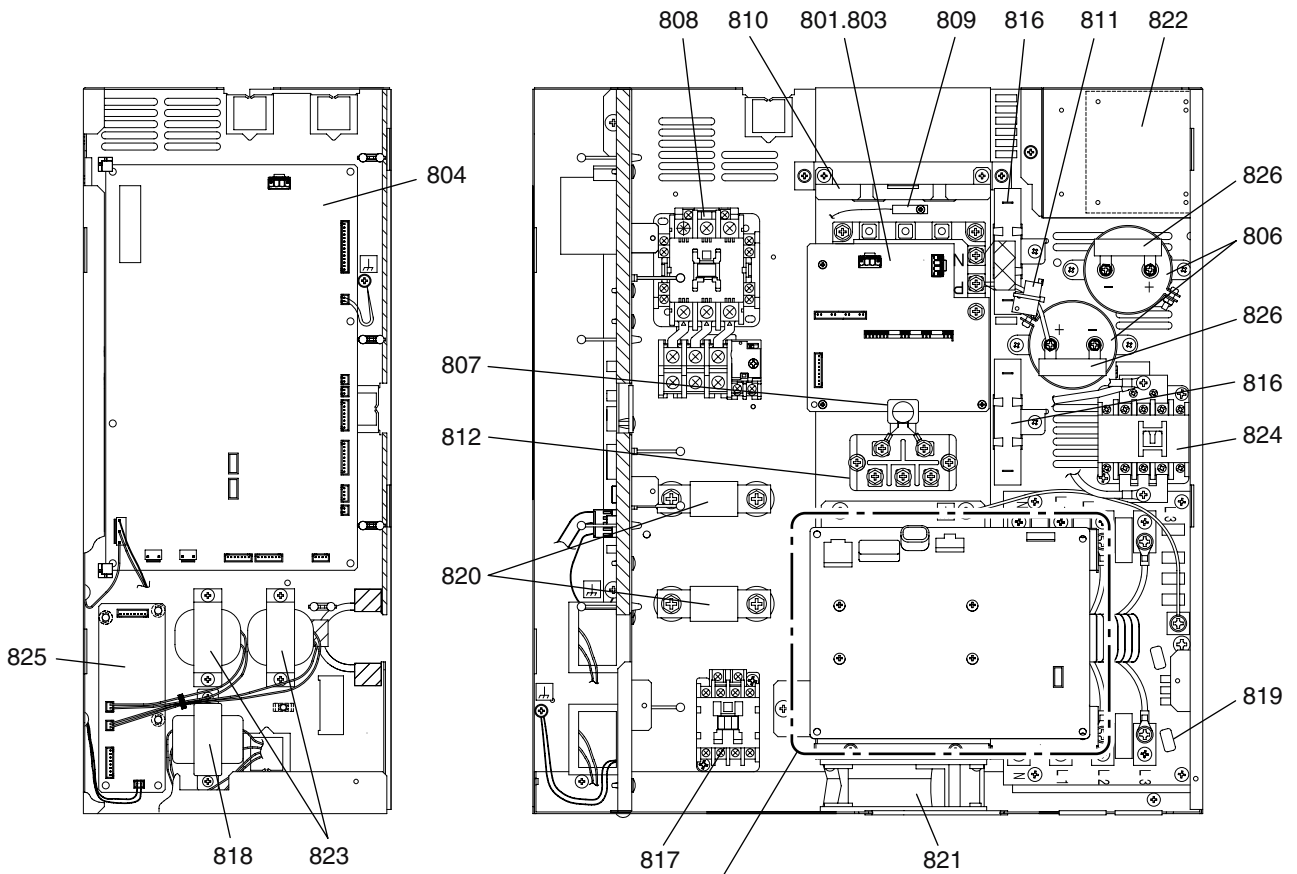
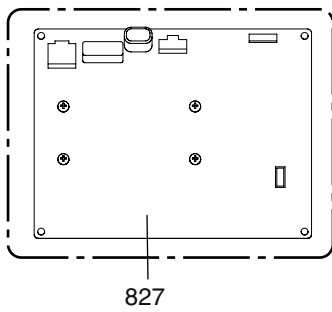

Fig.B

Fig.B

- Production number 52W**** and before



- Production number 51W**** and later (RoHS-compliant outdoor unit)

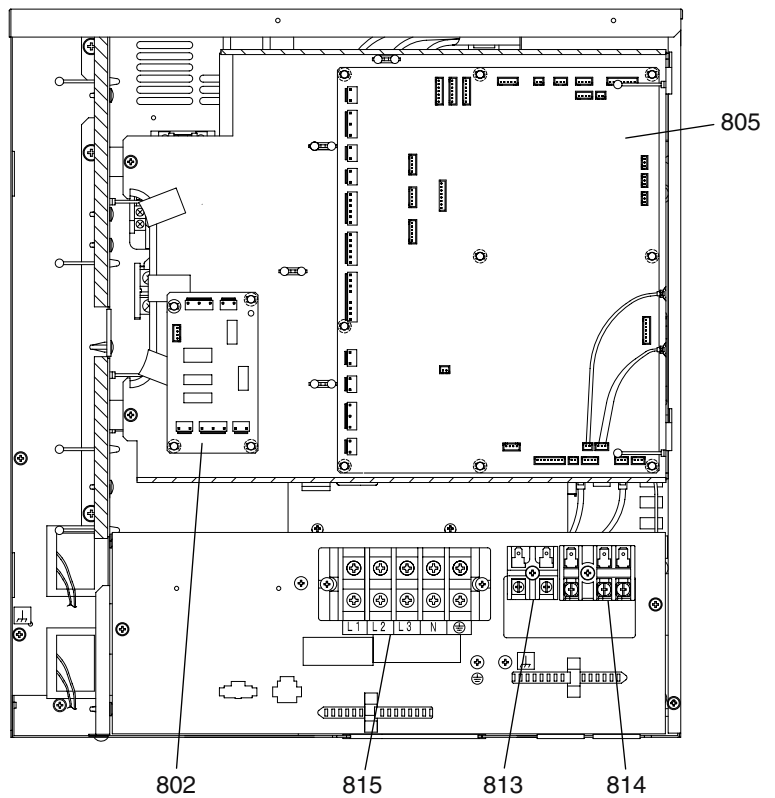
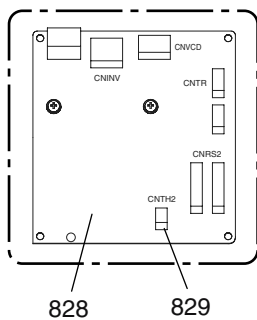

PUHY-P450, P500YGM-A(-BS)
 PUHY-P550, P600YGM-A(-BS)
 PUHY-P650YGM-A(-BS)

CONTROL BOX PARTS (2)

No.	Part No.	G : RoHS Apply Only W : RoHS Apply by Running Change		Spec.	PUHY-P450YGM-A	PUHY-P500YGM-A	PUHY-P550YGM-A	PUHY-P600YGM-A	Dwg. No.	Price	Revision History
			Part Name								
801	R63 Y04 249	G	IPM (Power module)	6MBP50RA120	1	1	1	1	W848413G10		
802	R63 Y60 280	G	Relay board		1	1	1	1	W629574G02		
803	R63 Y43 280	G	G/A board		1	1	1	1	W652112G02		
804	R63 Y25 321	G	INV board		1	1	1	1	W647875G04		
805	R63 Y47 281	G	Main board		1	1	1	1	W647876G15		
806	R63 R34 252	G	Capacitor	400V 3300μF<C11,C12>	2	2	2	2	P412293X01		
807	R63 L85 252	G	Capacitor assy	<ZNR14>	1	1	1	1	W886345G01		
808	R63 Y36 225	G	Magnetic starter	PAK-35JT-FC<51C2,52C2>	1	1	1	1	S427025H84		
809	R63 F14 201	G	Thermistor	<THHS>	1	1	1	1	P414095X01		
810	R63 Y02 287	G	AC current sensor	CHJ038CP2B <AC-CT>	1	1	1	1	W652122G01		
811	R63 A42 289	G	DC current sensor	<DC-CT>	1	1	1	1	P419079X02		
812	R63 Y12 320	G	Diode	DF60LB160<DS1>	1	1	1	1	W876941G06		
813	R61 008 246	G	Terminal block	<TB3>	1	1	1	1	BA73S950H02		C
814	R63 979 247	G	Terminal block	<TB7>	1	1	1	1	P436110X01		
815	R63 Y06 246	G	Terminal block	<TB1>	1	1	1	1	P436213X01		
816	R63 Y06 234	G	Resistor	40W, 47Ω<R11,R12>	2	2	2	2	P411141X01		
817	R63 Y29 225	G	Magnet contactor	PAK-11J<52F>	1	1	1	1	S427020H15		
818	R63 Y25 260	G	Transformer	230V/20.1V<T01>	1	1	1	1	P715378X02		
819	R63 Y11 293	G	Noise filter	CF4032C-MX2 <ACNF1>	1	1	1	1	P417012X01		
820	R63 Y09 241	G	Fuse	<F11,F12>	2	2	2	2	S423007H02		
821	R63 Y15 118	G	Fan	109S025UL<MF1>	1	1	1	1	W639916G01		
822	R61 009 259	G	Reactor	<DCL1>	1	1	1	1	P715429X01		C
823	R63 002 923	G	Choke coil	10mH 2A<L1,L2>	2	2	2	2	P715421X01		C
824	R63 Y28 225	G	Magnet contactor	PAK-21J,AC240V<52C1>	1	1	1	1	S427020H12		
825	R63 Y26 321	G	Filter board		1	1	1	1	W629574G06		
826	R63 Y04 234	G	Resistor	<R13,R14>	2	2	2	2	P411124X01		
★	827	R61 Y24 321	Fan INV board		1	1	1	1	W652171G02		
★	828	R63 Y74 281	G Fan INV board-A		1	1	1	1	W652171G05		
	829	R63 R49 200	G Thermistor	<THHS5>	1	1	1	1	W902268G01		
<p>★ RoHS-compliant outdoor units (production number 51W***** and later) use Fan INV board No. 828. Fan INV boards No. 827 and No. 828 are not interchangeable. If RoHS-compliance status information of a given unit (production number) is not available, procure Fan INV boards No. 827 and No. 828.</p>											

PUHY-P450, P500YGM-A(-BS)
 PUHY-P550, P600YGM-A(-BS)
 PUHY-P650YGM-A(-BS)

CONTROL BOX PARTS (2)

No.	Part No.	G : RoHS Apply Only W : RoHS Apply by Running Change	Part Name	Spec.	PUHY-P600YGM-A	PUHY-P450YGM-A-BS	PUHY-P500YGM-A-BS	PUHY-P650YGM-A-BS	Dwg. No.	Price	Revision History
801	R63 Y04 249	G	IPM (Power module)	6MBP50RA120	1	1	1	1	W848413G10		
802	R63 Y60 280	G	Relay board		1	1	1	1	W629574G02		
803	R63 Y43 280	G	G/A board		1	1	1	1	W652112G02		
804	R63 Y25 321	G	INV board		1	1	1	1	W647875G04		
805	R63 Y47 281	G	Main board		1	1	1	1	W647876G15		
806	R63 R34 252	G	Capacitor	400V 3300µF<C11,C12>	2	2	2	2	P412293X01		
807	R63 L85 252	G	Capacitor assy	<ZNR14>	1	1	1	1	W886345G01		
808	R63 Y36 225	G	Magnetic starter	PAK-35JT-FC<51C2,52C2>	1	1	1	1	S427025H84		
809	R63 F14 201	G	Thermistor	<THHS>	1	1	1	1	P414095X01		
810	R63 Y02 287	G	AC current sensor	CHJ038CP2B <AC-CT>	1	1	1	1	W652122G01		
811	R63 A42 289	G	DC current sensor	<DC-CT>	1	1	1	1	P419079X02		
812	R63 Y12 320	G	Diode	DF60LB160<DS1>	1	1	1	1	W876941G06		
813	R61 008 246	G	Terminal block	<TB3>	1	1	1	1	BA73S950H02		C
814	R63 979 247	G	Terminal block	<TB7>	1	1	1	1	P436110X01		
815	R63 Y06 246	G	Terminal block	<TB1>	1	1	1	1	P436213X01		
816	R63 Y06 234	G	Resistor	40W, 47Ω<R11,R12>	2	2	2	2	P411141X01		
817	R63 Y29 225	G	Magnet contactor	PAK-11J<52F>	1	1	1	1	S427020H15		
818	R63 Y25 260	G	Transformer	230V/20.1V<T01>	1	1	1	1	P715378X02		
819	R63 Y11 293	G	Noise filter	CF4032C-MX2 <ACNF1>	1	1	1	1	P417012X01		
820	R63 Y09 241	G	Fuse	<F11,F12>	2	2	2	2	S423007H02		
821	R63 Y15 118	G	Fan	109S025UL<MF1>	1	1	1	1	W639916G01		
822	R61 009 259	G	Reactor	<DCL1>	1	1	1	1	P715429X01		C
823	R63 002 923	G	Choke coil	10mH 2A<L1,L2>	2	2	2	2	P715421X01		C
824	R63 Y28 225	G	Magnet contactor	PAK-21J,AC240V<52C1>	1	1	1	1	S427020H12		
825	R63 Y26 321	G	Filter board		1	1	1	1	W629574G06		
826	R63 Y04 234	G	Resistor	<R13,R14>	2	2	2	2	P411124X01		
★	827	R61 Y24 321	Fan INV board		1	1	1	1	W652171G02		
★	828	R63 Y74 281	G Fan INV board-A		1	1	1	1	W652171G05		
	829	R63 R49 200	G Thermistor	<THHS5>	1	1	1	1	W902268G01		
<p>★ RoHS-compliant outdoor units (production number 51W***** and later) use Fan INV board No. 828. Fan INV boards No. 827 and No. 828 are not interchangeable. If RoHS-compliance status information of a given unit (production number) is not available, procure Fan INV boards No. 827 and No. 828.</p>											

No.	Part No.	G : RoHS Apply Only W : RoHS Apply by Running Change	Part Name	Spec.	PUHY-P600YGM-A-BS	PUHY-P650YGM-A-BS		Dwg. No.	Price	Revision History
801	R63 Y04 249	G	IPM (Power module)	6MBP50RA120	1	1		W848413G10		
802	R63 Y60 280	G	Relay board		1	1		W629574G02		
803	R63 Y43 280	G	G/A board		1	1		W652112G02		
804	R63 Y25 321	G	INV board		1	1		W647875G04		
805	R63 Y47 281	G	Main board		1	1		W647876G15		
806	R63 R34 252	G	Capacitor	400V 3300μF<C11,C12>	2	2		P412293X01		
807	R63 L85 252	G	Capacitor assy	<ZNR14>	1	1		W886345G01		
808	R63 Y36 225	G	Magnetic starter	PAK-35JT-FC<51C2,52C2>	1	1		S427025H84		
809	R63 F14 201	G	Thermistor	<THHS>	1	1		P414095X01		
810	R63 Y02 287	G	AC current sensor	CHJ038CP2B <AC-CT>	1	1		W652122G01		
811	R63 A42 289	G	DC current sensor	<DC-CT>	1	1		P419079X02		
812	R63 Y12 320	G	Diode	DF60LB160<DS1>	1	1		W876941G06		
813	R61 008 246	G	Terminal block	<TB3>	1	1		BA73S950H02		C
814	R63 979 247	G	Terminal block	<TB7>	1	1		P436110X01		
815	R63 Y06 246	G	Terminal block	<TB1>	1	1		P436213X01		
816	R63 Y06 234	G	Resistor	40W, 47Ω<R11,R12>	2	2		P411141X01		
817	R63 Y29 225	G	Magnet contactor	PAK-11J<52F>	1	1		S427020H15		
818	R63 Y25 260	G	Transformer	230V/20.1V<T01>	1	1		P715378X02		
819	R63 Y11 293	G	Noise filter	CF4032C-MX2 <ACNF1>	1	1		P417012X01		
820	R63 Y09 241	G	Fuse	<F11,F12>	2	2		S423007H02		
821	R63 Y15 118	G	Fan	109S025UL<MF1>	1	1		W639916G01		
822	R61 009 259	G	Reactor	<DCL1>	1	1		P715429X01		C
823	R63 002 923	G	Choke coil	10mH 2A<L1,L2>	2	2		P715421X01		C
824	R63 Y28 225	G	Magnet contactor	PAK-21J,AC240V<52C1>	1	1		S427020H12		
825	R63 Y26 321	G	Filter board		1	1		W629574G06		
826	R63 Y04 234	G	Resistor	<R13,R14>	2	2		P411124X01		
★	827	R61 Y24 321	Fan INV board		1	1		W652171G02		
★	828	R63 Y74 281	G Fan INV board-A		1	1		W652171G05		
	829	R63 R49 200	G Thermistor	<THHS5>	1	1		W902268G01		
<p>★ RoHS-compliant outdoor units (production number 51W**** and later) use Fan INV board No. 828. Fan INV boards No. 827 and No. 828 are not interchangeable. If RoHS-compliance status information of a given unit (production number) is not available, procure Fan INV boards No. 827 and No. 828.</p>										

