

February 2009

No. OCB442
REVISED EDITION-A

PARTS CATALOG

Series PKFY Wall Mounted R410A / R407C / R22

Indoor unit
[Model names]

[Service Ref.]

PKFY-P32VHM-E

**PKFY-P32VHM-E
PKFY-P32VHM-ER1**

PKFY-P40VHM-E

**PKFY-P40VHM-E
PKFY-P40VHM-ER1**

PKFY-P50VHM-E

**PKFY-P50VHM-E
PKFY-P50VHM-ER1**

Revision:

- PKFY-P32/40/50VHM-ER1 are added in REVISED EDITION-A.
- Some descriptions have been modified.

- Please void OCB442.

Note:

- RoHS compliant products have <G> mark on the spec name plate.

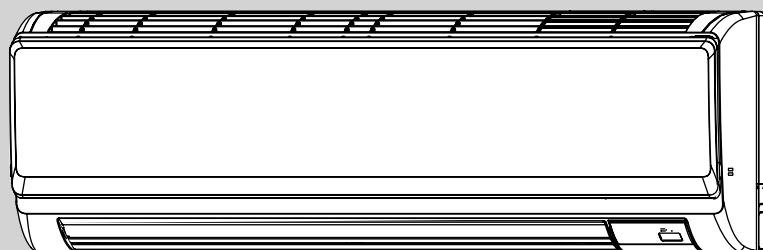

INDOOR UNIT

CONTENTS

1. RoHS PARTS LIST 2
2. OPTIONAL PARTS 6

SERVICE MANUAL (OCH442)

PANEL AND HEAT EXCHANGER PARTS

PKFY-P32VHM-E

PKFY-P32VHM-ER1

PKFY-P40VHM-E

PKFY-P40VHM-ER1

PKFY-P50VHM-E

PKFY-P50VHM-ER1

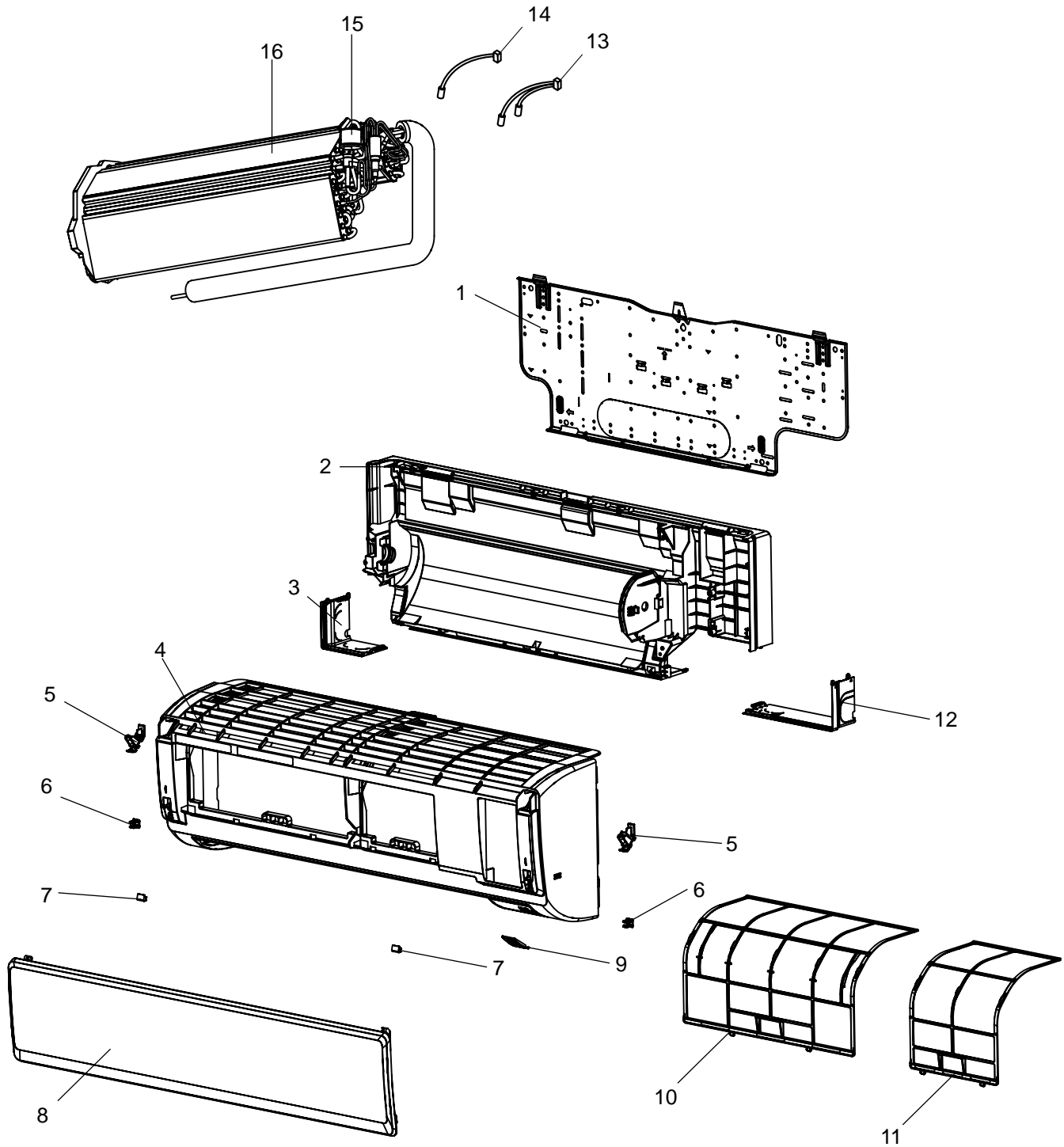

No.	RoHS	Part No.	Part Name	Specification	Q'ty/set				Remarks (Drawing No.)	Wiring Diagram Symbol	Recom- mended Q'ty
					PKFY-P-VHM-E		PKFY-P-VHM-ER1				
					32, 40	50	32, 40	50			
1	G	T7W E02 808	BACK PLATE		1	1					
	G	R01 E08 808	BACK PLATE				1	1			
2	G	T7W E02 635	BOX ASSY		1	1					
	G	R01 E02 635	BOX ASSY				1	1			
3	G	T7W E05 658	CORNER BOX (L)		1	1					
	G	R01 E30 658	CORNER BOX (L)				1	1			
4	G	T7W E12 651	FRONT PANEL		1	1					
	G	R01 E15 651	FRONT PANEL				1	1			
5	G	T7W E00 054	HOLDER (R.L)		1	1			2pcs/set		
	G	R01 E14 054	HOLDER (R.L)				1	1	2pcs/set		
6	G	T7W E01 054	CATCH		1	1			2pcs/set		
	G	R01 E15 054	CATCH				1	1	2pcs/set		
7	G	R01 E05 096	SCREW CAP		1	1	1	1	2pcs/set		
8	G	T7W E07 691	GRILLE		1	1					
	G	R01 E58 691	GRILLE				1	1			
9	G	T7W E07 658	RECEIVER COVER		1	1					
	G	R01 E31 658	RECEIVER COVER				1	1			
10	G	T7W E02 500	FILTER		1	1					
	G	R01 E27 500	FILTER				1	1			
11	G	T7W E03 500	FILTER		1	1					
	G	R01 E28 500	FILTER				1	1			
12	G	T7W E04 658	CORNER BOX (R)		1	1					
	G	R01 E29 658	CORNER BOX (R)				1	1			
13	G	T7W E59 202	THERMISTOR		1	1				TH22/23	
	G	R01 N17 202	THERMISTOR				1	1		TH22/23	
14	G	R01 H07 202	THERMISTOR		1	1	1	1		TH24	
15	G	R01 H07 401	EXPANSION VALVE		1	1				LEV	
	G	R01 H28 401	EXPANSION VALVE				1	1		LEV	
16	G	T7W H97 480	HEAT EXCHANGER		1						
	G	T7W H98 480	HEAT EXCHANGER			1					
	G	T7W K35 480	HEAT EXCHANGER				1				
	G	T7W K36 480	HEAT EXCHANGER					1			

FAN AND ELECTRICAL PARTS

PKFY-P32VHM-E

PKFY-P32VHM-ER1

PKFY-P40VHM-E

PKFY-P40VHM-ER1

PKFY-P50VHM-E

PKFY-P50VHM-ER1

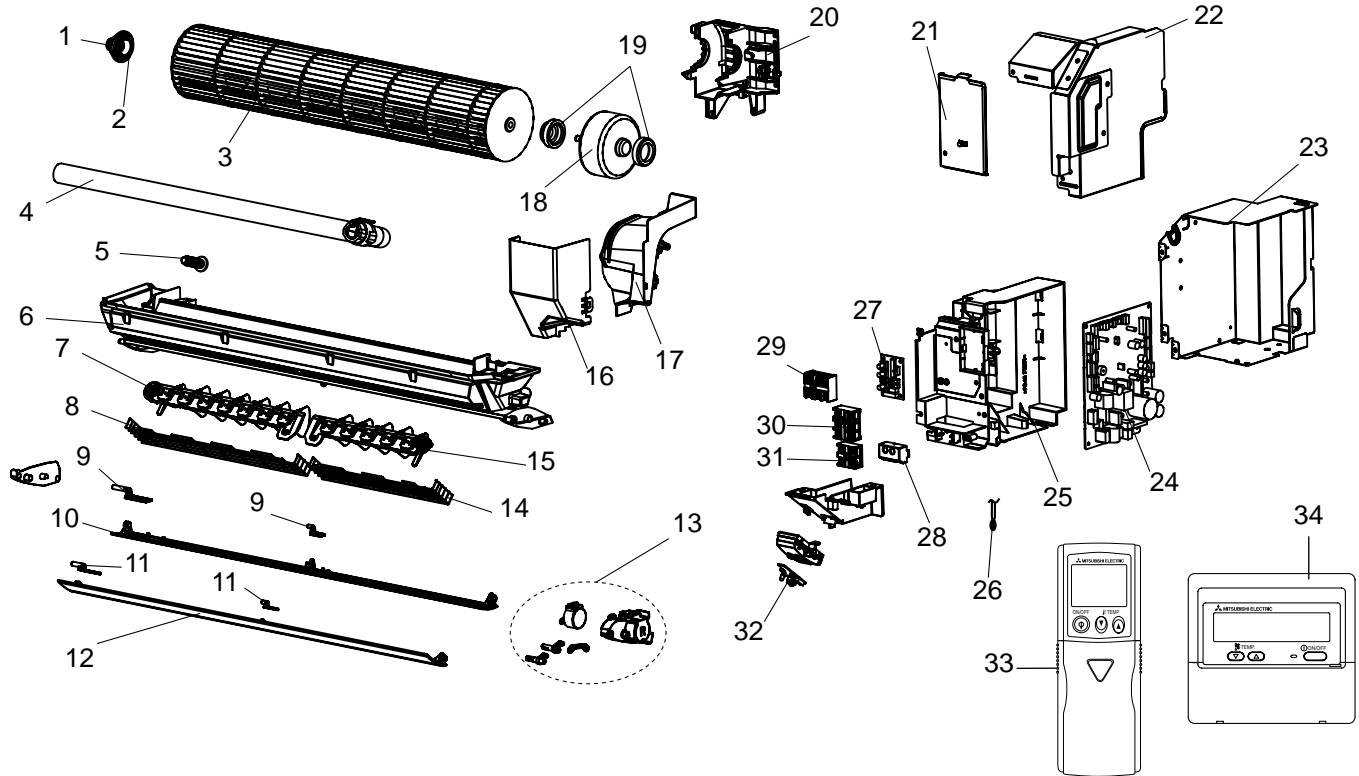

Part numbers that are circled are not shown in the illustration.

No.	RoHS	Part No.	Part Name	Specifi- cation	Q'ty/set		Remarks (Drawing No.)	Wiring Diagram Symbol	Recom- mended Q'ty
					PKFY-P-VHM-E	PKFY-P-VHM-ER1			
					32, 40, 50	32, 40, 50			
1	G	R01 E01 102	BEARING MOUNT		1	1			
2	G	R01 E04 103	SLEEVE BEARING		1	1			
3	G	T7W E05 114	LINEFLOW FAN		1				
	G	R01 E42 114	LINEFLOW FAN			1			
4	G	R01 E06 527	DRAIN HOSE		1				
	G	R01 E09 527	DRAIN HOSE			1			
5	G	R01 E03 524	DRAIN CAP		1	1			
6	G	T7W E02 530	NOZZLE ASSY		1		with No.7,15		
	G	R01 E01 530	NOZZLE ASSY			1	with No.7,15		
7	G	T7W E06 038	GUIDE VANE ASSY-L		1				
	G	R01 E07 038	GUIDE VANE ASSY-L			1			
8	G	T7W E19 675	FAN GUARD-L		1	1			
9	G	T7W E01 063	VANE SHAFT-UC		1		2pcs/set		
	G	R01 E06 063	VANE SHAFT-UC			1	2pcs/set		
10	G	T7W E12 002	AUTO VANE-U		1				
	G	R01 E32 002	AUTO VANE-U			1			
11	G	T7W E00 063	VANE SHAFT-TC		1		2pcs/set		
	G	R01 E05 063	VANE SHAFT-TC			1	2pcs/set		

Continued to the next page.

From the previous page.

No.	RoHS	Part No.	Part Name	Specifi- cation	Q'ty/set		Remarks (Drawing No.)	Wiring Diagram Symbol	Recom- mended Q'ty
					PKFY-P-VHM-E	PKFY-P-VHM-ER1			
					32, 40, 50	32, 40, 50			
12	G	T7W E11 002	AUTO VANE-T		1				
	G	R01 E31 002	AUTO VANE-T			1			
13	G	T7W E09 223	VANE MOTOR		1				
	G	R01 E27 223	VANE MOTOR			1			
14	G	T7W E18 675	FAN GUARD-R		1	1			
15	G	T7W E05 038	GUIDE VANE ASSY-R		1				
	G	R01 E06 038	GUIDE VANE ASSY-R			1			
16	G	T7W E02 031	WATER COVER		1				
	G	R01 E00 031	WATER COVER			1			
17	G	T7W E00 126	MOTOR BAND		1				
	G	R01 E03 126	MOTOR BAND			1			
18	G	T7W E37 762	FAN MOTOR		1		with No.19	MF	
	G	R01 E51 220	FAN MOTOR			1	with No.19	MF	
19	G	T7W E02 105	RUBBER MOUNT		1				
	G	R01 E08 105	RUBBER MOUNT			1			
20	G	T7W E13 130	MOTOR BED		1				
	G	R01 E44 130	MOTOR BED			1			
21	G	—	TOP COVER		1	1	(BK02B838G03)		
22	G	—	SIDE COVER		1	1	(BK02A479G28)		
23	G	—	CONTROL BOX		1	1	(BK00B899G04)		
24	G	T7W E76 310	CONTROLLER BOARD		1			I.B, S.B	
	G	R01 V04 310	CONTROLLER BOARD			1		I.B, S.B	
25	G	—	PB BOX		1	1	(BK25A475G05)		
26	G	R01 N20 202	THERMISTOR		1	1	with tube & band	TH21	
27	G	T7W E01 294	ADDRESS BOARD		1	1		A.B	
28	G	T7W E03 031	SWITCH BOARD COVER		1				
	G	R01 E01 031	SWITCH BOARD COVER			1			
29	G	T7W E49 716	TERMINAL BLOCK	3P(L,N,⊕)	1	1		TB2	
30	G	T7W E50 716	TERMINAL BLOCK	3P(M1,M2,S)	1	1		TB5	
31	G	T7W E33 716	TERMINAL BLOCK	2P(1,2)	1	1		TB15	
32	G	R01 E10 317	RECEIVER ASSY		1	1		W.B	
33	G	—	WIRELESS REMOTE CONTROLLER	PAR-FL32MA	1	1			
34	G	—	REMOTE CONTROLLER	PAR-21MAA	1	1			
35	G	T7W E08 304	CABLE ASSY (ADDRESS)		1				
	G	R01 E13 304	CABLE ASSY (ADDRESS)			1			
36	G	T7W E06 239	FUSE	3.15A 250V	1			FUSE	
	G	R01 E15 239	FUSE	3.15A 250V		1		FUSE	
37	G	R01 E12 304	CABLE (VANE MOTOR)		1	1			

2**OPTIONAL PARTS****2-1. WIRELESS REMOTE CONTROLLER**

Part No.	PAR-FL32MA
----------	------------

2-2. WIRED REMOTE CONTROLLER (MA REMOTE CONTROLLER)

Part No.	PAR-21MAA
----------	-----------

2-3. WIRED REMOTE CONTROLLER (ME REMOTE CONTROLLER)

Part No.	PAR-F27MEA
----------	------------

2-4. DRAIN PUMP KIT

Part No.	PAC-SH75DM-E
----------	--------------

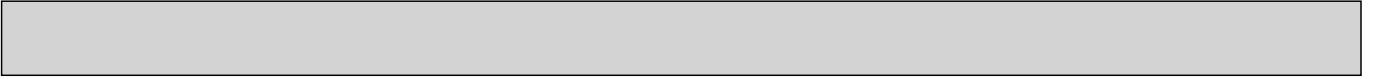

CITY MULTI™

 **MITSUBISHI ELECTRIC CORPORATION**

HEAD OFFICE : TOKYO BLDG., 2-7-3, MARUNOUCHI, CHIYODA-KU TOKYO 100-8310, JAPAN
