

PARTS CATALOG

Series PLFY Ceiling Cassettes

R410A / R407C / R22

Indoor unit

[Model names]

PLFY-P20VCM-E2

[Service Ref.]

PLFY-P20VCM-E2.TH

PLFY-P25VCM-E2

PLFY-P25VCM-E2.TH

PLFY-P32VCM-E2

PLFY-P32VCM-E2.TH

PLFY-P40VCM-E2

PLFY-P40VCM-E2.TH

Note :

- RoHS compliant products have <G> mark on spec name plate.

CONTENTS

1. RoHS PARTS LIST.....2

SERVICE MANUAL (OCH463)

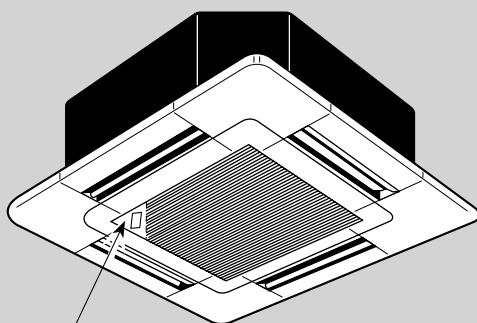

Model name indication

INDOOR UNIT

PANEL PARTS
SLP-2ALW
SLP-2AAW

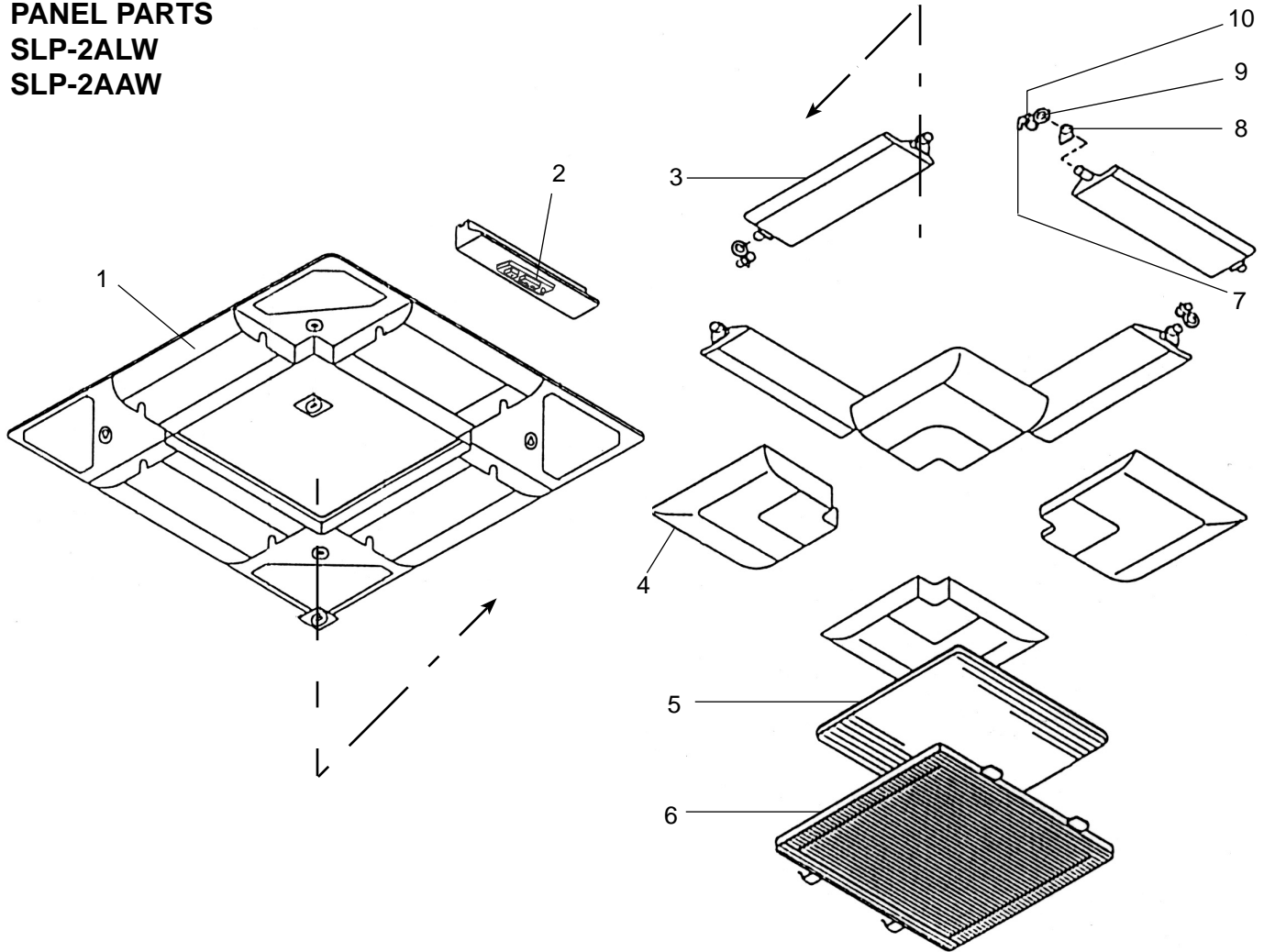

No.	RoHS	Part No.	Part Name	Specification	Q'ty/set		Remarks (Drawing No.)	Wiring Diagram Symbol	Recom- mended Q'ty
					SLP-2				
					ALW	AAW			
1	G	E17 423 003	AIR OUTLET GRILLE		1				
	G	E17 424 003	AIR OUTLET GRILLE			1			
2	G	E17 103 317	WIRELESS REMOTE CONTROL BOARD		1		W.B		
3	G	E17 423 037	AUTO VANE		4	4			
4	G	E17 423 975	CORNER PANEL		4	4			
5	G	E17 103 100	AIR FILTER		1	1			
6	G	E17 423 010	INTAKE GRILLE		1	1			
7	G	E17 103 303	VANE MOTOR		4	4		MV	
8	G	E17 103 044	VANE BUSH		8	8			
9	G	E17 103 031	GEAR (V)		4	4			
10	G	E17 103 032	GEAR (M)		4	4			

ELECTRICAL PARTS

PLFY-P20VCM-E2.TH

PLFY-P32VCM-E2.TH

PLFY-P25VCM-E2.TH

PLFY-P40VCM-E2.TH

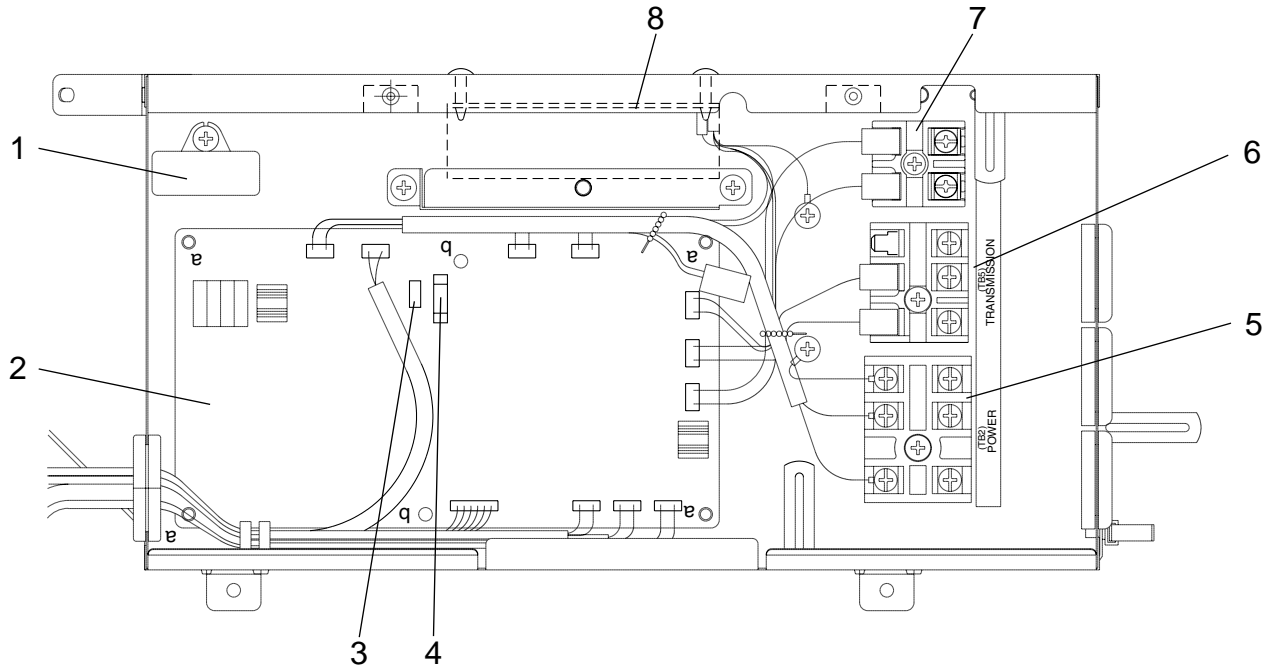

No.	RoHS	Parts No.	Parts name	Specification	Q'ty/set				Remarks (Drawing No.)	Wiring Diagram Symbol	Recom- mended Q'ty
					PLFY-						
					P20	P25	P32	P40			
1	G	E17 154 350	CAPACITOR	1.0 μ F / 440VAC	1					C1	
	G	E12 095 350	CAPACITOR	1.5 μ F / 440VAC		1	1	1		C1	
2	G	E17 580 447	INDOOR CONTROLLER BOARD		1	1	1	1		I.B	
3	G	E12 661 385	VARISTOR		1	1	1	1		ZNR	
4	G	E17 250 382	FUSE	250V 6.3A	1	1	1	1		FUSE	
5	G	E17 155 375	TERMINAL BLOCK	3P(L, N, \ominus)	1	1	1	1		TB2	
6	G	E17 154 375	TERMINAL BLOCK	3P(M1, M2, S)	1	1	1	1		TB5	
7	G	E17 156 375	TERMINAL BLOCK	2P(1, 2)	1	1	1	1		TB15	
8	G	E17 154 440	INDOOR POWER BOARD		1	1	1	1		P.B	

FUNCTIONAL PARTS
PLFY-P20VCM-E2.TH
PLFY-P25VCM-E2.TH
PLFY-P32VCM-E2.TH
PLFY-P40VCM-E2.TH

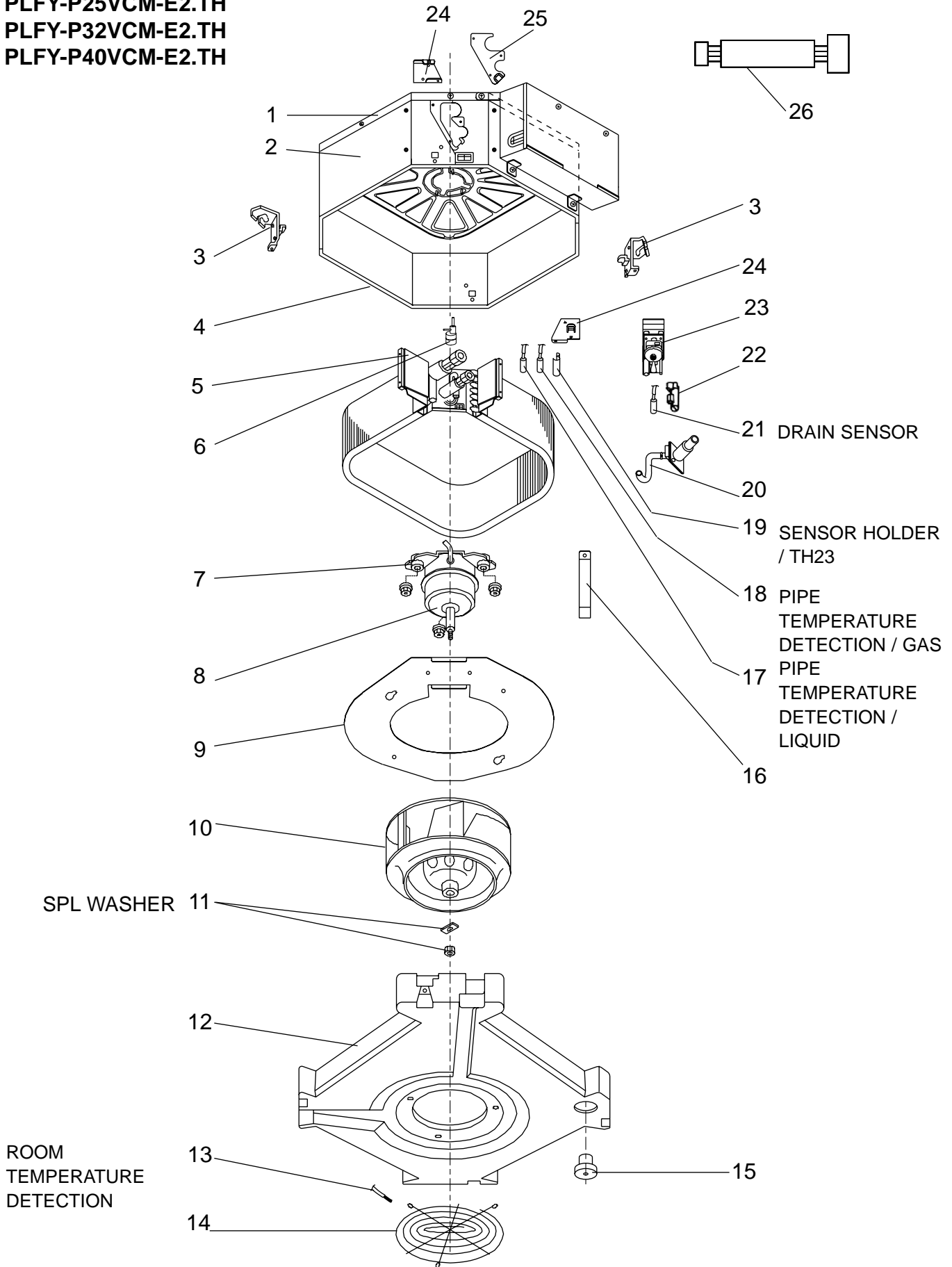



No.	RoHS	Parts No.			Parts name	Specification	Q'ty/set				Remarks (Drawing No.)	Wiring Diagram Symbol	Recom- mended Q'ty
							PLFY-						
							P20	P25	P32	P40			
							VCM-E2.TH						
1	G	E17	104	290	BASE		1	1	1	1			
2	G	E17	104	124	DRUM-1		1	1	1	1			
3	G	E17	104	808	LEG-1		2	2	2	2			
4	G	E17	105	124	DRUM-2		1	1	1	1			
5	G	E17	154	620	INDOOR HEAT EXCHANGER		1	1					
	G	E17	155	620	INDOOR HEAT EXCHANGER				1	1			
6	G	E17	154	640	LINEAR EXPANSION VALVE		1	1	1	1		LEV	
7	G	E17	104	105	MOTOR MOUNT		3	3	3	3	3PCS/SET		
8	G	E17	168	300	INDOOR FAN MOTOR	PK6V11-LF	1					MF	
	G	E17	162	300	INDOOR FAN MOTOR	PK6V15-LD		1				MF	
	G	E17	164	300	INDOOR FAN MOTOR	PK6V20-LL			1			MF	
	G	E17	166	300	INDOOR FAN MOTOR	PK6V20-LM				1		MF	
9	G	E17	104	816	FLAT PLATE		1	1	1	1			
10	G	E17	104	502	TURBO FAN		1	1	1	1			
11	G	E17	104	097	SPL WASHER		1	1	1	1			
12	G	E17	104	700	DRAIN PAN		1	1	1	1			
13	G	E17	154	308	ROOM TEMPERATURE DETECTION		1	1	1	1		TH21	
14	G	E17	104	520	FAN GUARD		1	1	1	1			
15	G	E17	104	524	DRAIN PLUG		1	1	1	1			
16	G	E17	104	648	COIL SUPPORT		1	1	1	1			
17	G	E17	154	307	PIPE TEMPERATURE DETECTION/LIQUID		1	1	1	1		TH22	
18	G	E17	154	309	PIPE TEMPERATURE DETECTION/GAS		1	1	1	1		TH23	
19	G	E17	154	241	SENSOR HOLDER/TH23	(TH23)	1	1	1	1			
20	G	E17	104	702	DRAIN HOSE		1	1	1	1			
21	G	E17	104	266	DRAIN SENSOR		1	1	1	1		DS	
22	G	E17	104	241	SENSOR HOLDER	(DS)	1	1	1	1			
23	G	E17	104	355	DRAIN PUMP		1	1	1	1		DP	
24	G	E17	104	809	LEG-2		2	2	2	2			
25	G	E17	154	006	COVER (DRUM)		1	1	1	1			
26	G	E17	580	087	WIRELESS ADAPTER CABLE		1	1	1	1			



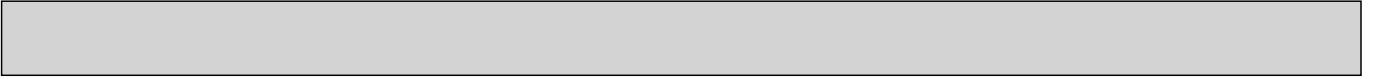

CITY MULTI™

