

Air-Conditioners For Building Application INDOOR UNIT

PCFY-P·VKM-E

For use with the R410A, R407C & R22 Uso del refrigerante R410A, R407C e R22
Bei Verwendung von R410A, R407C & R22 Για χρήση με τα R410A, R407C και R22
A utiliser avec le R410A, R407C et le R22 Para utilização com o R410A, R407C e o R22
Bij gebruik van R410A, R407C & R22 R410A, R407C ve R22 ile beraber kullanmak için
Para utilizar con el R410A, R407C y el R22 Для использования с моделями R410A, R407C и R22

INSTALLATION MANUAL

For safe and correct use, read this manual and the outdoor unit installation manual thoroughly before installing the air-conditioner unit.

FOR INSTALLER**English (GB)**

INSTALLATIONSHANDBUCH

Aus Sicherheitsgründen und zur richtigen Anwendung vor Installation der Klimaanlage die vorliegende Bedienungsanleitung und das Installationshandbuch gründlich durchlesen.

FÜR INSTALLATEURE**Deutsch (D)**

MANUEL D'INSTALLATION

Avant d'installer le climatiseur, lire attentivement ce manuel, ainsi que le manuel d'installation de l'appareil extérieur pour une utilisation sûre et correcte.

POUR L'INSTALLATEUR**Français (F)**

INSTALLATIEHANDLEIDING

Lees deze handleiding en de installatiehandleiding van het buitenapparaat zorgvuldig door voordat u met het installeren van de airconditioner begint.

VOOR DE INSTALLATEUR**Nederlands (NL)**

MANUAL DE INSTALACIÓN

Para un uso seguro y correcto, lea detalladamente este manual de instalación antes de montar la unidad de aire acondicionado.

PARA EL INSTALADOR**Español (E)**

MANUALE DI INSTALLAZIONE

Per un uso sicuro e corretto, prima di installare il condizionatore d'aria leggere attentamente il presente manuale ed il manuale d'installazione dell'unità esterna.

PER L'INSTALLATORE**Italiano (I)**

ΕΓΧΕΙΡΙΔΙΟ ΟΔΗΓΙΩΝ ΕΓΚΑΤΑΣΤΑΣΗΣ

Για σωστή και ασφαλή χρήση, διαβάστε προσεκτικά αυτό το εγχειρίδιο, καθώς και το εγχειρίδιο εγκατάστασης της εξωτερικής μονάδας, πριν από την εγκατάσταση της μονάδας κλιματιστικού.

ΓΙΑ ΑΥΤΟΝ ΠΟΥ ΚΑΝΕΙ ΤΗΝ ΕΓΚΑΤΑΣΤΑΣΗ**Ελληνικά (GR)**

MANUAL DE INSTALAÇÃO

Para uma utilização segura e correcta, leia atentamente este manual e o manual de instalação da unidade exterior antes de instalar o aparelho de ar condicionado.

PARA O INSTALADOR**Português (P)**

MONTAJ ELKİTABI

Emniyetli ve doğru kullanım için, klima cihazını monte etmeden önce bu kılavuzu ve dış ünite montaj kılavuzunu tamamiyle okuyun.

MONTÖR İÇİN**Türkçe (TR)**

РУКОВОДСТВО ПО УСТАНОВКЕ

Для обеспечения безопасной и надлежащей эксплуатации внимательно прочтите данное руководство и руководство по установке наружного прибора перед установкой кондиционера.

ДЛЯ УСТАНОВИТЕЛЯ**Русский (RU)**

Contents

1. Safety precautions.....	2	5. Drainage piping work.....	5
2. Installation location.....	2	6. Electrical work.....	5
3. Installing the indoor unit.....	2	7. Test run (Fig. 7-1).....	7
4. Installing the refrigerant piping.....	4		

Note:
The phrase “Wired remote controller” in this installation manual refers only to the PAR-21MAA.
If you need any information for the other remote controller, please refer to either the installation manual or initial setting manual which are included in these boxes.

1. Safety precautions

- ▶ Before installing the unit, make sure you read all the “Safety precautions”.
- ▶ Please report to your supply authority or obtain their consent before connecting this equipment to the power supply system.

⚠ Warning:
Describes precautions that must be observed to prevent danger of injury or death to the user.

⚠ Caution:
Describes precautions that must be observed to prevent damage to the unit.

After installation work has been completed, explain the “Safety Precautions,” use, and maintenance of the unit to the customer according to the information in the Operation Manual and perform the test run to ensure normal operation. Both the Installation Manual and Operation Manual must be given to the user for keeping. These manuals must be passed on to subsequent users.

- ⚠ Warning:**
- Ask the dealer or an authorized technician to install the air conditioner.
 - Install the unit at a place that can withstand its weight.
 - Use only specified cables for wiring. The wiring connections must be made securely with no tension applied on the terminal connections. Also, never splice the cables for wiring (unless otherwise indicated in this document). Failure to observe these instructions may result in overheating or a fire.
 - Use only accessories authorized by Mitsubishi Electric and ask the dealer or an authorized technician to install them.
 - Do not touch the heat exchanger fins.
 - Install the air conditioner according to this Installation Manual.
 - Have all electric work done by a licensed electrician according to local regulations.

- ⚠ Caution:**
- Do not use the existing refrigerant piping, when use R410A or R407C refrigerant.
 - Use ester oil, either oil or alkylbenzene (small amount) as the refrigerant oil to coat flares and flange connections, when use R410A or R407C refrigerant.
 - Do not use the air conditioner where food, pets, plants, precision instruments, or artwork are kept.
 - Do not use the air conditioner in special environments.
 - Ground the unit.

- ⊘ : Indicates an action that must be avoided.
- ⚠ : Indicates that important instructions must be followed.
- ⚡ : Indicates a part which must be grounded.
- ⚠ : Indicates that caution should be taken with rotating parts.
- ⚠ : Indicates that the main switch must be turned off before servicing.
- ⚠ : Beware of electric shock.
- ⚠ : Beware of hot surface.
- ⚠ ELV : At servicing, please shut down the power supply for both the Indoor and Outdoor Unit.

⚠ Warning:
Carefully read the labels affixed to the main unit.

- If the air conditioner is installed in a small room, measures must be taken to prevent the refrigerant concentration from exceeding the safety limit even if the refrigerant should leak.
- The cut face punched parts may cause injury by cut, etc. The installers are requested to wear protective equipment such as gloves, etc.
- When installing or relocating, or servicing the outdoor unit, use only the specified refrigerant (R410A) to charge the refrigerant lines. Do not mix it with any other refrigerant and do not allow air to remain in the lines. If air is mixed with the refrigerant, then it can be the cause of abnormal high pressure in the refrigerant line, and may result in an explosion and other hazards. The use of any refrigerant other than that specified for the system will cause mechanical failure or system malfunction or unit breakdown. In the worst case, this could lead to a serious impediment to securing product safety.

- Install a leak circuit breaker, as required.
- Use power line cables of sufficient current carrying capacity and rating.
- Use only a circuit breaker and fuse of the specified capacity.
- Do not touch the switches with wet fingers.
- Do not touch the refrigerant pipes during and immediately after operation.
- Do not operate the air conditioner with the panels and guards removed.
- Do not turn off the power immediately after stopping operation.

2. Installation location

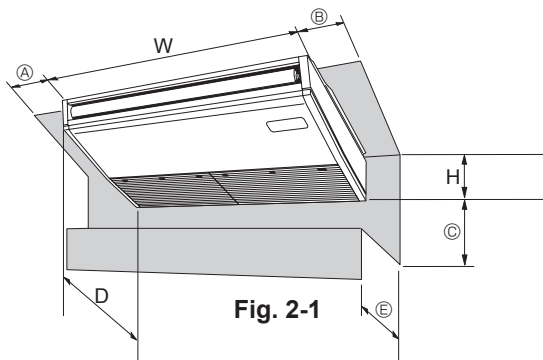

Fig. 2-1

2.1. Outline dimensions (Indoor unit) (Fig. 2-1)

Select a proper position allowing the following clearances for installation and maintenance. (mm)

Models	W	D	H	A	B	C	E
P40	960	680	230	Min. 270	Min. 300	Min. 500	Max. 250
P63	1280	680	230	Min. 270	Min. 300	Min. 500	Max. 250
P100	1600	680	230	Min. 270	Min. 300	Min. 500	Max. 250
P125	1600	680	230	Min. 270	Min. 300	Min. 500	Max. 250

⚠ Warning:
Mount the indoor unit on a ceiling strong enough to withstand the weight of the unit.

2.2. Outline dimensions (Outdoor unit)

Refer to the outdoor unit installation manual.

3. Installing the indoor unit

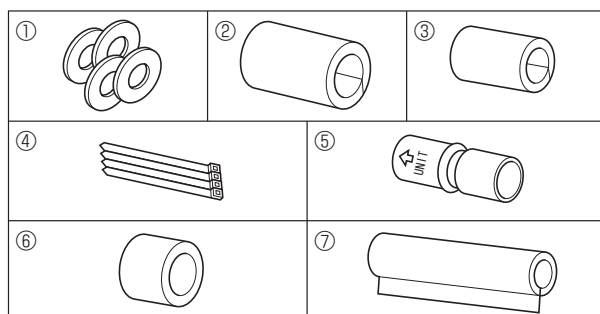

Fig. 3-1

3.1. Check the indoor unit accessories (Fig. 3-1)

The indoor unit should be supplied with the following accessories (contained in the inside of the intake grille).

	Accessory name	Q'ty
①	Washer	4 pcs
②	Pipe cover	1 pc Large size (For gas tubing)
③	Pipe cover	1 pc Small size (For liquid tubing)
④	Band	4 pcs
⑤	Joint socket	1 pc Marked with “UNIT”
⑥	Socket cover	1 pc
⑦	Drain tubing cover	1 pc

3. Installing the indoor unit

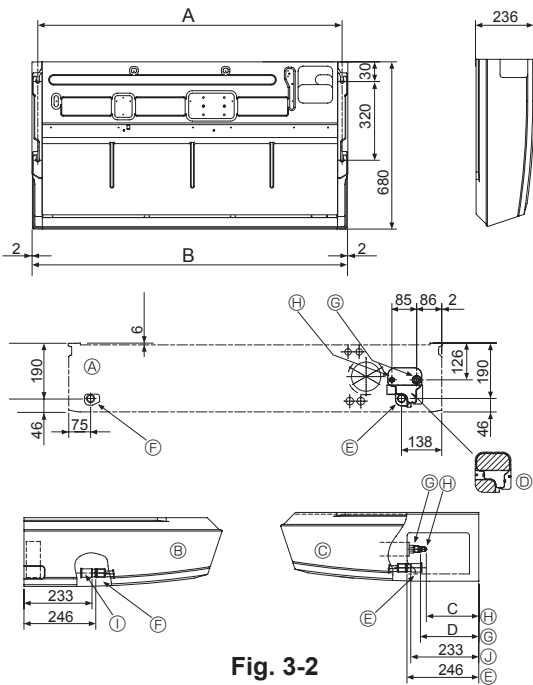

Fig. 3-2

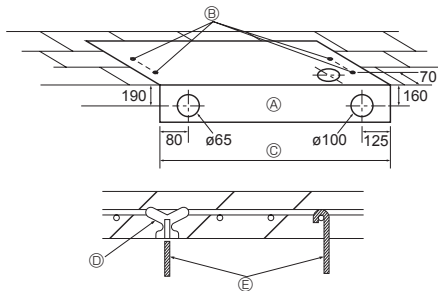

Fig. 3-3

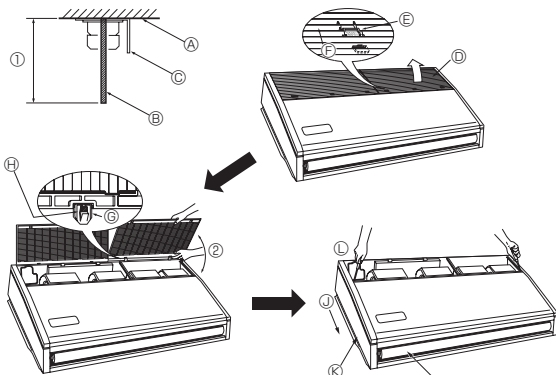

Fig. 3-4

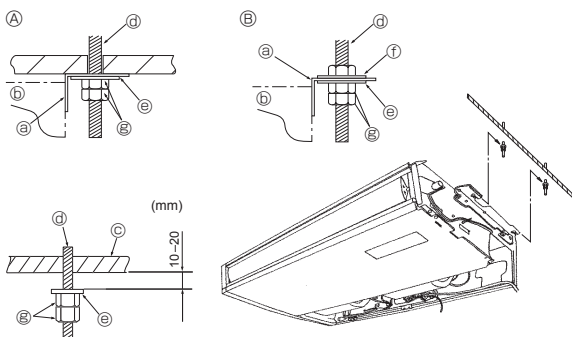

Fig. 3-5

3.2. Preparation for installation (Fig. 3-2)

3.2.1. Suspension bolt installing spacing (mm)

Models	A	B
P40	917	960
P63	1237	1280
P100,125	1557	1600

3.2.2. Refrigerant and drain tubing location (mm)

Models	C	D
P40	184	203
P63	180	200
P100,125	180	200

- Ⓐ Front side outlet
- Ⓑ Left side outlet
- Ⓒ Right side outlet
- Ⓓ Independent piece (Removable)
- Ⓔ Right drain tubing
- Ⓕ Left drain tubing
- Ⓖ Gas tubing
- Ⓗ Liquid tubing
- Ⓘ Rubber plug
- ⓵ with Joint socket

3.2.3. Selection of suspension bolts and tubing positions (Fig. 3-3)

Using the pattern paper provided for installation, select proper positions for suspension bolts and tubing and prepare relative holes.

- Ⓐ Pattern paper
- Ⓑ Suspension bolt hole
- Ⓒ Indoor unit width

Secure the suspension bolts or use angle stock braces or square timbers for bolt installation.

- Ⓓ Use inserts of 100 kg to 150 kg each.
- Ⓔ Use suspension bolts of W3/8 or M10 in size.

3.2.4. Indoor unit preparation (Fig. 3-4)

1. Install the suspending bolts. (Procure the W3/8 or M10 bolts locally.)

Predetermine the length from the ceiling (Ⓐ within 100 mm).

- Ⓐ Ceiling surface
- Ⓑ Suspending bolt
- Ⓒ Suspending bracket

2. Remove the intake grille.

Slide the intake grille holding knobs (at 2 or 3 locations) backward to open the intake grille.

3. Remove the side panel.

Remove the side panel holding screws (one in each side, right and left) then slide the side panel forward for removal.

- Ⓓ Intake grille
- Ⓔ Slide the side panel forward.
- Ⓕ Intake grille holding knob
- Ⓖ Side panel
- Ⓗ Slide
- Ⓖ Remove the side panel holding screws.
- Ⓒ Hinge
- Ⓗ Remove the protective vinyl of vane.
- Ⓗ Pushing the hinge, pull out the intake grille.
- Ⓗ Forcing open the intake grille or opening it to an angle of more than 120° may damage the hinges.

3.3. Installing the indoor unit (Fig. 3-5)

Use a proper suspending method depending on the presence or absence of ceiling materials as follows.

- Ⓐ In the presence of ceiling materials
- Ⓑ In the absence of ceiling materials
- Ⓒ Suspending bracket
- Ⓓ Unit
- Ⓒ Ceiling
- Ⓓ Suspending bolt
- Ⓔ Washer
- Ⓗ Washer (Local procurement)
- Ⓖ Double nuts

1) Directly suspending the unit

Installing procedures

1. Install the washer (Ⓗ) (supplied with the unit) and the nuts (to be locally procured).
2. Set (hook) the unit through the suspending bolts.
3. Tighten the nuts.

Check the unit installing condition.

- Check that the unit is horizontal between the right and left sides.
- Check that the front and the rear of suspending brackets are horizontal. (To keep drainage, the unit is inclined to the suspending brackets. The unit slopes continuously downward from the front to the rear is the right installation position.)

3. Installing the indoor unit

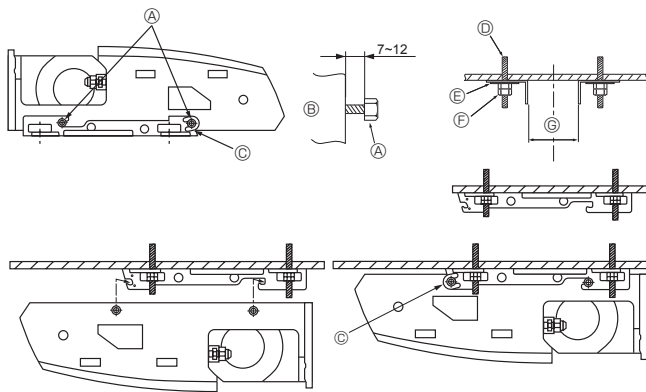

Fig. 3-6

2) Installing the suspending bracket first onto the ceiling (Fig. 3-6)

Installing procedures

1. Remove the suspending brackets and U-shaped washers from the unit.
2. Adjust the suspending bracket holding bolts on the unit.
3. Attach the suspending brackets to the suspending bolts.
4. Check that the suspending brackets are horizontal (front and rear/right and left).
5. Set (hook) the unit to the suspending brackets.
6. Tighten fixed bolts of the suspending brackets.

* Be sure to install the U-shaped washers.

- Ⓐ Suspending bracket holding bolt
- Ⓑ Unit
- Ⓒ U-shaped washer
- Ⓓ Suspending bolt
- Ⓔ Washer ①
- Ⓕ Double nuts

	(mm)	
Ⓔ	P40	882 - 887
	P63	1202 - 1207
	P100, P125	1522 - 1527

4. Installing the refrigerant piping

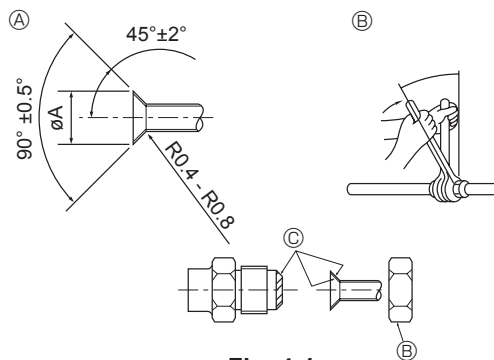

Fig. 4-1

4.1. Connecting pipes (Fig. 4-1)

- When commercially available copper pipes are used, wrap liquid and gas pipes with commercially available insulation materials (heat-resistant to 100 °C or more, thickness of 12 mm or more).
- The indoor parts of the drain pipe should be wrapped with polyethylene foam insulation materials (specific gravity of 0.03, thickness of 9 mm or more).
- Apply thin layer of refrigerant oil to pipe and joint seating surface before tightening flare nut.
- Use two wrenches to tighten piping connections.
- Use refrigerant piping insulation provided to insulate indoor unit connections. Insulate carefully.

⚠ **Warning:**

When installing the unit, securely connect the refrigerant pipes before starting the compressor.

Ⓐ Flare cutting dimensions

Copper pipe O.D. (mm)	Flare dimensions øA dimensions (mm)
ø6.35	8.7 - 9.1
ø9.52	12.8 - 13.2
ø12.7	16.2 - 16.6
ø15.88	19.3 - 19.7
ø19.05	22.9 - 23.3

Ⓒ Refrigerant pipe sizes & Flare nut tightening torque

	R407C or R22				R410A				Flare nut O.D.	
	Liquid pipe		Gas pipe		Liquid pipe		Gas pipe		Liquid pipe (mm)	Gas pipe (mm)
	Pipe size (mm)	Tightening torque (N.m)	Pipe size (mm)	Tightening torque (N.m)	Pipe size (mm)	Tightening torque (N.m)	Pipe size (mm)	Tightening torque (N.m)		
P40	ODø6.35 (1/4")	14 - 18	ODø12.7 (1/2")	49 - 61	ODø6.35 (1/4")	14 - 18	ODø12.7 (1/2")	49 - 61	17	26
P63	ODø9.52 (3/8")	34 - 42	ODø15.88 (5/8")	68 - 82	ODø9.52 (3/8")	34 - 42	ODø15.88 (5/8")	68 - 82	22	29
P100/125	ODø9.52 (3/8")	34 - 42	ODø19.05 (3/4")	68 - 82*	ODø9.52 (3/8")	34 - 42	ODø15.88 (5/8")	68 - 82	22	29

* Flare nut ø19.05 (purchased locally): Gas pipe of P100, P125 (R407C or R22).

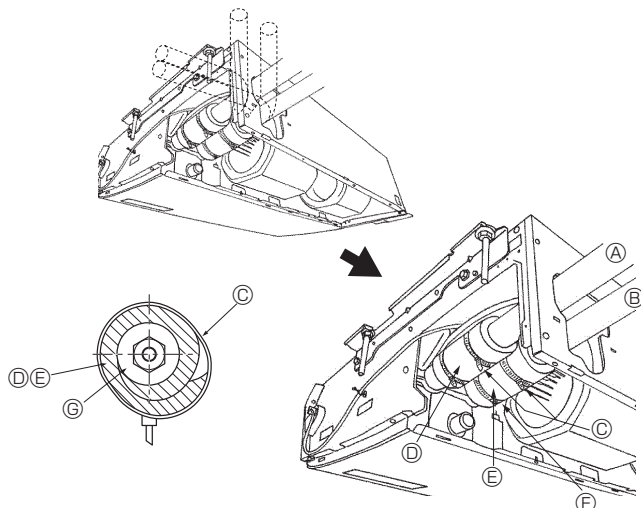

Fig. 4-2

Ⓒ Apply refrigerating machine oil over the entire flare seat surface.

4.2. Indoor unit (Fig. 4-2)

Installing procedures

1. Slide the supplied pipe cover ② over the gas tubing until it is pressed against the sheet metal inside the unit.
2. Slide the provided pipe cover ③ over the liquid tubing until it is pressed against the sheet metal inside the unit.
3. Tighten the pipe covers ② and ③ at the both ends (20 mm) with the supplied bands ④.

- Ⓐ Gas tubing
- Ⓑ Liquid tubing
- Ⓒ Band ④
- Ⓓ Pipe cover ②
- Ⓔ Pipe cover ③
- Ⓕ Press the pipe cover against the sheet metal.
- Ⓖ Refrigerant tubing heat insulating material

5. Drainage piping work

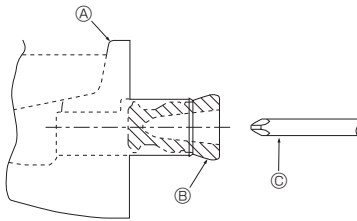

Fig. 5-1

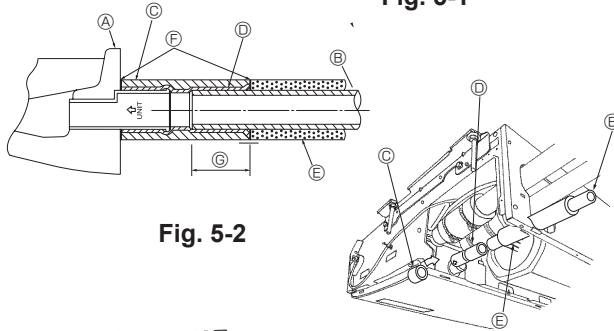

Fig. 5-2

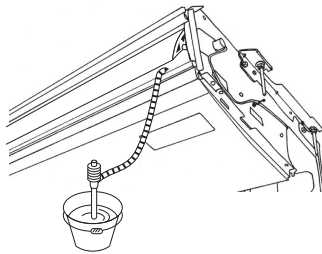

Fig. 5-3

- For left side tubing, be sure to insert the rubber plug into the right drain port. (Fig. 5-1)
- Use VP-20 (O.D. ø26 (1") PVC TUBE) for drain piping and provide 1/100 or more downward slope.
- After completion of work, check that correct drain is available from the outflow port of the drain tubing.

- Ⓐ Drain pan
- Ⓑ Plug
- Ⓒ Insert the driver etc.in the plug deeply.

Installing procedures (Fig. 5-2)

1. Attach the joint socket ⑤ supplied with the unit to the drain port on the unit with a vinyl chloride adhesive.
2. Fasten the socket cover ⑥ supplied with the unit to the joint socket ⑤.
3. Attach the field drain tubing (VP-20) to the joint socket ⑤ with a vinyl chloride adhesive.
4. Wrap the drain tubing cover ⑦ supplied with the unit. (Seam taping)

- Ⓐ Drain pan
- Ⓑ Drain tubing
- Ⓒ Socket cover ⑥
- Ⓓ Joint socket ⑤
- Ⓔ Drain tubing cover ⑦
- Ⓕ Stopper
- Ⓖ Insertion length 37mm

5. Check for correct drainage. (Fig. 5-3)

* Fill the drain pan with water of about 1 L from the air outlet.

GB

6. Electrical work

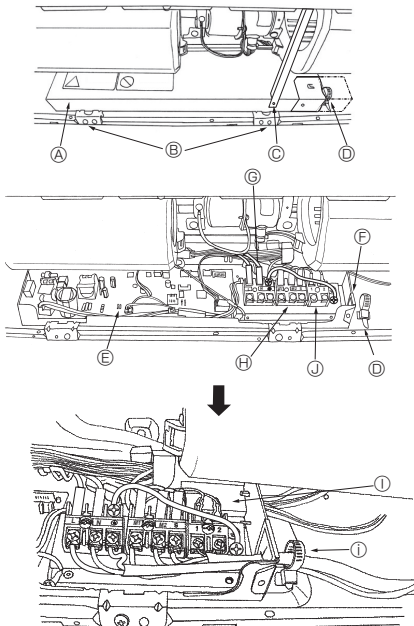

Fig. 6-1

6.1. Electric wiring (Fig. 6-1)

Wiring procedures

1. Remove the tapping screw ③ then remove the beam.
2. Remove the (2) tapping screws ④ then remove the electric part cover ①.
3. Connect the electric wires securely to the corresponding terminals.
4. Replace the removed parts.
5. Tie the electric wires with the local wiring clamp located in the right side of the junction box.

A means for the disconnection of the supply with an isolation switch, or similar device, in all active conductors shall be incorporated in the fixed wiring.

* Label each breaker according to purpose (heater, unit etc.)

- Ⓐ Cover
- Ⓑ Set screws (2 pcs)
- Ⓒ Set screws (Beam)
- Ⓓ Wiring clamp
- Ⓔ Control board
- Ⓕ Wire service entrance
- Ⓖ Terminal block for power supply
- Ⓖ Terminal block for transmission cable
- Ⓖ Address board
- Ⓖ Terminal block for MA Remote controller
- Ⓖ Secure with the wiring clamp.

6.2. Power supply wiring

- Wiring size must comply with the applicable local and national codes.
 - Install an earth line longer than other cables.
 - Power supply codes of appliance shall not be lighter than design 60245 IEC 53 or 60227 IEC 53.
 - A switch with at least 3 mm contact separation in each pole shall be provided by the air conditioner installation.
- Power cable size : more than 1.5mm² (3-core)

⚠ Warning:

Never splice the power cable or the indoor-outdoor connection cable, otherwise it may result in a smoke, a fire or communication failure.

► Use earth leakage breaker (NV).

For breaker, means shall be provided to ensure disconnection of all active phase conductors of the supply.

6. Electrical work

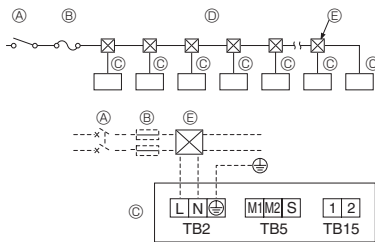

Fig. 6-2

[Fig.6-2]

- Ⓐ Switch 16 A
- Ⓑ Overcurrent protection 16 A
- Ⓒ Indoor unit
- Ⓓ Total operating current be less than 16 A
- Ⓔ Pull box

6.3. Types of control cables

1. Wiring transmission cables

Types of transmission cable	Shielding wire CVVS or CPEVS
Cable diameter	More than 1.25 mm ²
Length	Less than 200m

2. M-NET Remote control cables

Types of remote control cable	Shielding wire MVVS
Cable diameter	0.5 to 1.25 mm ²
Length	Add any portion in excess of 10m to within the longest allowable transmission cable length 200m

3. MA Remote control cables

Types of remote control cable	2-core cable (unshielded)
Cable diameter	0.3 to 1.25 mm ²
Length	Less than 200m

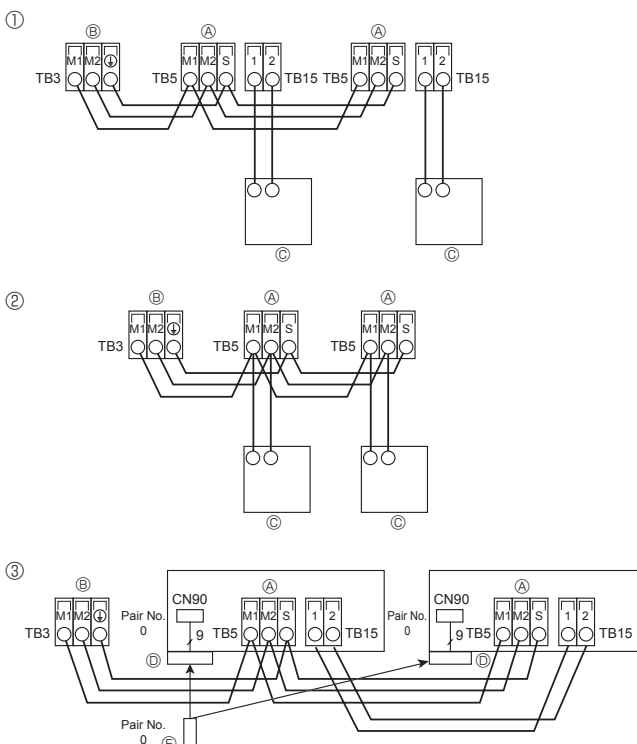

Fig. 6-3

6.4. Connecting remote controller, indoor and outdoor transmission cables (Fig. 6-3)

- Connect indoor unit TB5 and outdoor unit TB3. (Non-polarized 2-wire)
The "S" on indoor unit TB5 is a shielding wire connection. For specifications about the connecting cables, refer to the outdoor unit installation manual.
- Install a remote controller following the manual supplied with the remote controller.
- Connect the remote controller's transmission cable within 10 m using a 0.75 mm² core cable. If the distance is more than 10 m, use a 1.25 mm² junction cable.
- ① MA Remote controller
 - Connect the "1" and "2" on indoor unit TB15 to a MA remote controller. (Non-polarized 2-wire)
 - DC 9 to 13 V between 1 and 2 (MA remote controller)
- ② M-NET Remote controller
 - Connect the "M1" and "M2" on indoor unit TB5 to a M-NET remote controller. (Non-polarized 2-wire)
 - DC 24 to 30 V between M1 and M2 (M-NET remote controller)
- ③ Wireless remote controller(When installing wireless signal receiver)
 - Connect the wire of wireless signal receiver (9-pole cable) to CN90 of indoor controller board.
 - When more than two units are run under group control using wireless remote controller, connect TB15 each with the same number.
 - To change Pair No. setting, refer to installation manual attached to wireless remote controller. (In initial setting of indoor unit and wireless remote controller, Pair No. is 0.)

- Ⓐ Terminal block for indoor transmission cable
- Ⓑ Terminal block for outdoor transmission cable(M1(A), M2(B), ⊕(S))
- Ⓒ Remote controller
- Ⓓ wireless signal receiver
- Ⓔ wireless remote controller

6.5. Setting addresses (Fig. 6-4)

(Be sure to operate with the main power turned OFF.)

- There are 2 types of rotary switch setting available: setting addresses 1 to 9 and over 10, and setting branch numbers.

① How to set addresses

Example: If Address is "3", remain SW12 (for over 10) at "0", and match SW11(for 1 to 9) with "3".

② How to set branch numbers SW14 (Series R2 only)

Match the indoor unit's refrigerant pipe with the BC controller's end connection number.
Remain other than series R2 at "0".

- The rotary switches are all set to "0" when shipped from the factory. These switches can be used to set unit addresses and branch numbers at will.
- The determination of indoor unit addresses varies with the system at site. Set them referring to the Data Book.

- Ⓐ Address board

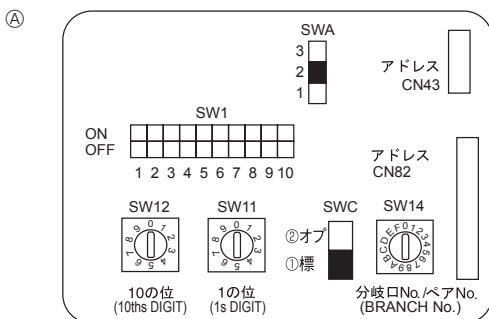

Fig. 6-4

6. Electrical work

6.6. Switch setting for different ceiling heights (Fig.6-4)

With this unit, the air flow rate and fan speed can be adjusted by setting the SWA (slide switch). Select a suitable setting from the table below according to the installation location.

* Make sure the SWA switch is set, otherwise problems such as not getting cool/warm may occur.

SWA	3 (high ceiling)	2 (standard)	1 (silent)
P40, P63	3.5 m	2.7 m	2.5 m
P100, P125	4.2 m	3.0 m	2.6 m

SWA: Initial setting: 2 (Standard)

6.7. Sensing room temperature with the built-in sensor in a remote controller (Fig.6-4)

If you want to sense room temperature with the built-in sensor in a remote controller, set SW1-1 on the control board to "ON". The setting of SW1-7 and SW1-8 as necessary also makes it possible to adjust the air flow at a time when the heating thermometer is OFF.

7. Test run (Fig. 7-1)

7.1. Before test run

- ▶ After completing installation and the wiring and piping of the indoor and outdoor units, check for refrigerant leakage, looseness in the power supply or control wiring, wrong polarity, and no disconnection of 1 phase in the supply.
- ▶ Use a 500-volt megohmmeter to check that the resistance between the power supply terminals and ground is at least 1.0 MΩ.

- ▶ Do not carry out this test on the control wiring (low voltage circuit) terminals.

⚠ Warning:

Do not use the air conditioner if the insulation resistance is less than 1.0 MΩ.

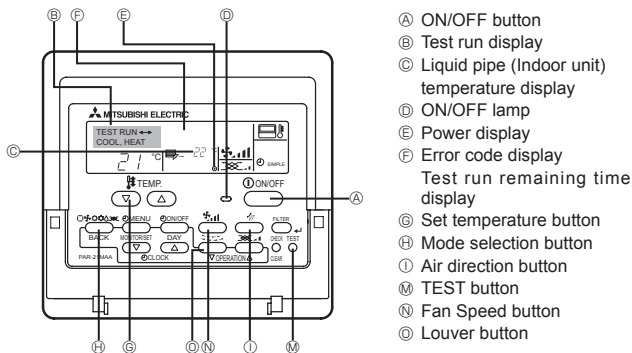

Fig. 7-1

7.2. Test run

Using wired remote controller (Fig. 7-1)

- ① Turn on the power at least 12 hours before the test run.
- ② Press the [TEST] button twice. ➡ "TEST RUN" liquid crystal display
- ③ Press the [Mode selection] button and switch to the cooling (or heating) mode. ➡ Make sure that cold (or warm) wind is blown out.
- ④ Press the [Fan speed] button. ➡ Make sure that the wind speed is switched.
- ⑤ Press the [Air direction button] or [Louver button]. ➡ Check operation of the vane or louver.
- ⑥ Check operation of the outdoor unit fan.
- ⑦ Release test run by pressing the [ON/OFF] button. ➡ Stop
- ⑧ Register a telephone number.

The telephone number of the repair shop, sales office, etc., to contact if an error occurs can be registered in the remote controller. The telephone number will be displayed when an error occurs. For registration procedures, refer to the operation manual for the indoor unit.

Note:

- If an error code is displayed on the remote controller or if the air conditioner does not operate properly, refer to the outdoor unit installation manual or other technical materials.
- The OFF timer is set for the test run to automatically stop after 2 hours.
- During the test run, the time remaining is shown in the time display.
- During the test run, the temperature of the indoor unit refrigerant pipes is shown in the room temperature display of the remote controller.
- When the VANE or LOUVER button is pressed, the message "NOT AVAILABLE" may appear on the remote controller display depending on the indoor unit model, but this is not a malfunction.

This product is designed and intended for use in the residential,
commercial and light-industrial environment.

The product at hand is
based on the following
EU regulations:

- Low Voltage Directive 2006/95/EC
 - Electromagnetic Compatibility Directive
2004/108/EC
 - Machinery Directive 2006/42/EC
 - Energy-related Products Directive
2009/125/EC*
- *Only P40/P63/P100

Please be sure to put the contact address/telephone number on
this manual before handing it to the customer.

MITSUBISHI ELECTRIC CORPORATION

HEAD OFFICE: TOKYO BLDG., 2-7-3, MARUNOUCHI, CHIYODA-KU, TOKYO 100-8310, JAPAN

Authorized representative in EU: MITSUBISHI EUROPE, B.V. HARMAN HOUSE,

1 GEORGE STREET, UXBRIDGE,
MIDDLE SEX UB8 1QQ.U.K.