

TYPE	CEILING RECESSED LOSSNAY	VOLUME	
MODEL	LGH-50RX ₄ -E	SIGN	

Heat exchange system	Air-to-air total heat exchange(sensible heat + latent heat)exchange					
Heat exchange element material	Partition-spacing plate-special treated paper					
Cladding	Galvanized steel sheet					
Heat insulating material	Self-extinguishing urethane foam					
Motor	Totally enclosed capacitor permanent split-phase induction motor.4 poles,2 units					
Blower	220mm dia. Centrifugal fan					
Filter material	Non-woven fabrics filter(Gravitational method 82%)					
Operation enviroment (Supply air)	-10℃ to 40℃,RH 80% or less					
Operation and room air temperature	OA temperature shall be -15℃ to +40℃, less than 80%RH, with general air conditioning room environment. Subject to outdoor air conditioning unit. Pre-Heat OA in the case of using Lossnay in the cold region less than -15℃.					
Functions	Lossnay ventilation/Bypass ventilation High(Extra high)-Low switching					
Weight	33kg					
Power source	Single phase 220-240V					
Frequency	50Hz					
Ventilation mode	Lossnay ventilation			Bypass ventilation		
Fan speed	Extra high	High	Low	Extra high	High	Low
Current (A)	0.94-0.95	0.89-0.90	0.57-0.60	0.95-0.96	0.90-0.93	0.58-0.60
Power consumption (W)	204-225	193-214	123-142	206-228	196-221	125-142
Air volume	(m ³ /h)	500	500	350	500	500
	(L/s)	139	139	97	139	139
External static pressure	(mmH ₂ O)	15.3	6.1	3.1	15.3	6.1
	(Pa)	150	60	30	150	60
Temperature exchange efficiency (%)		77	77	82	-	-
Enthalpy exchange efficiency (%)	Heating	67.5	67.5	73.5	-	-
	Cooling	64.5	64.5	71.5	-	-
Noise (dB)	Measured at 1.5m under the center of panel	33-34	29.5-31.5	23.5-24.5	34-35.5	31-33
	Air outlets	41-42	37.5-39.5	29.5-30.5	42-43.5	39-41
Starting current	Under 1.9A less					
Insulation resistance	10MΩ or more (500V megger)					
Dielectric strength	AC 1500V 1 minute					

■ Characteristic curve

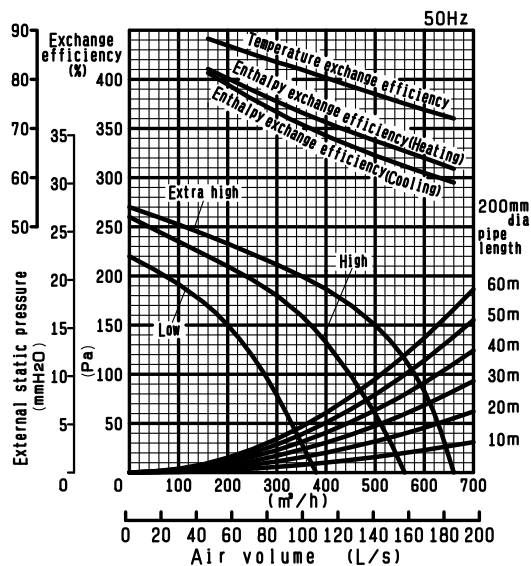

※ Attention

1. Cold operation mode(※1) is to start repeating in the case that OA temperature is less than -10℃.
- ※1. Intaking air in the operation for 60min. followed by stop operation for 10min.
2. The current, power consumption and efficiency are based on the above air flow rate.
3. The noise at the air outlets is the values at a 45° angle, 1.5 meters in front of the unit.
4. Fan speed can be switched between High and Low. Multi Ventilation Mode should set on Lossnay unit.
5. Lossnay ventilation mode is to start automatically in the case that OA temprature is less than -8℃, even if Bypass ventilation is set by remote controller. Remote controller continue to show "Bypass ventilation" in this case.

※2. Specifications may be subject to change without notice.

SPECIFICATIONS	DATE	TYPE	CEILING RECESSED LOSSNAY	
	15-Nov.-04	MODEL	LGH-50RX ₄ -E (50Hz)	
MITSUBISHI ELECTRIC CORPORATION		NUMBER	ND104357A	1/5

■ Outline drawings

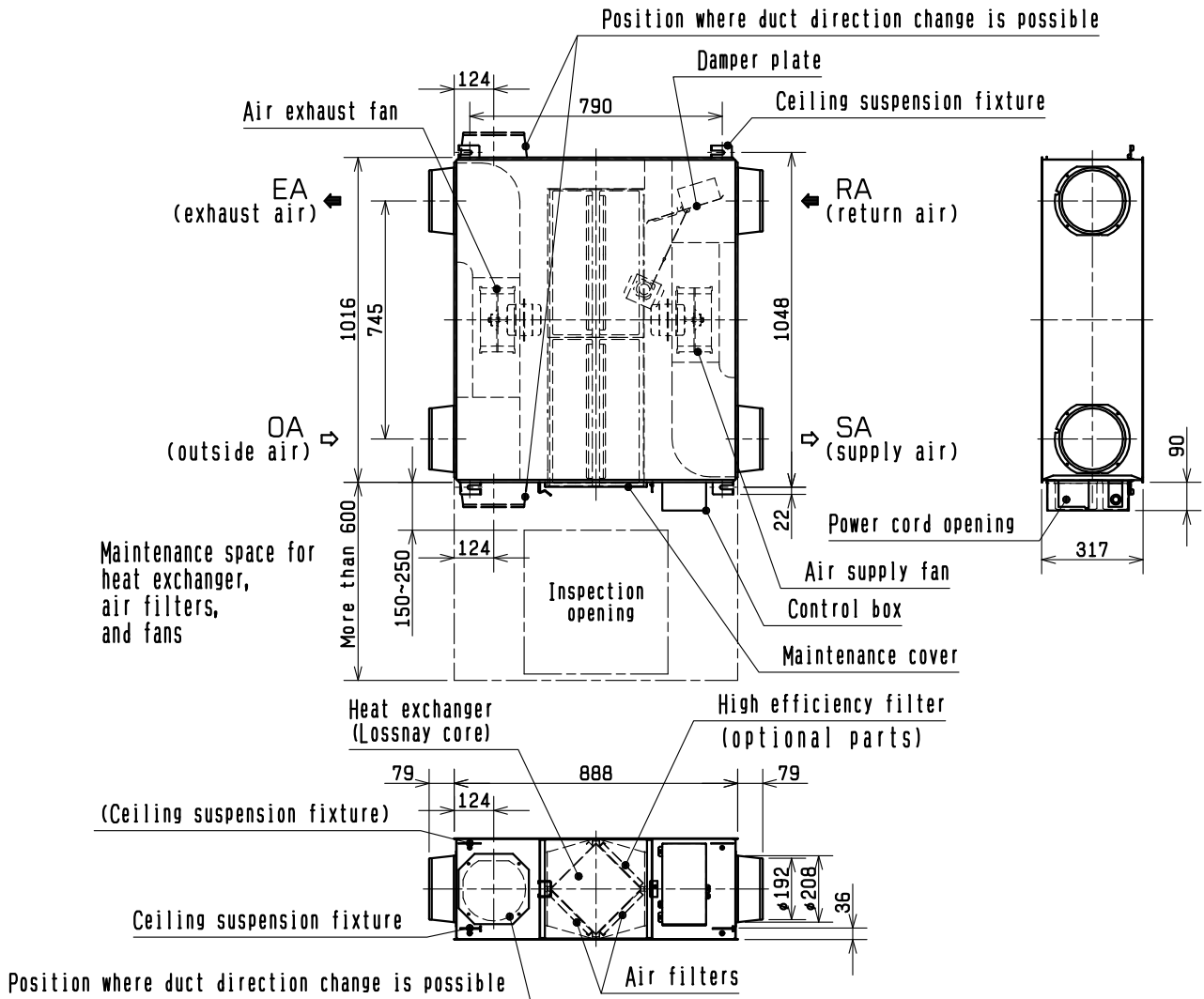

	UNIT	SCALE
	mm	N. T. S

■ Attention

1. If condensation is expected to form, heat up the fresh outside air using a duct heater, etc.
2. An inspection opening (450×450 or 600×600mm) must be installed on the filter and Lossnay core removing side.
3. Provide heat insulation to prevent dew condensation along the two outside ducts.
(outside air duct and exhaust air duct)
4. Do a measure for there not to be intrusion of rainwater.
*Outside air duct and exhaust air duct put equal or more than 1/30 descent inclinations to the side of wall.
*Where rain falls directly on the machinery, use the weather cover to prevent entry of rainwater.
5. Be sure to connect the grounding wire.

*Specifications may be subject to change without notice.

OUTLINE DRAWINGS	DATE	TYPE MODEL	CEILING RECESSED LOSSNAY	
	15-Nov.-04			LGH-50RX4-E
MITSUBISHI ELECTRIC CORPORATION		NUMBER	ND104357A	2/5

Outline drawings

Symbol explanation

- NOTE 1. TM1, TM2, TM3, TM4, TB5 shown in dotted lines are field work.
 2. Breaker should be provided by the customer.
 3. Be sure to connect the grounding wire.

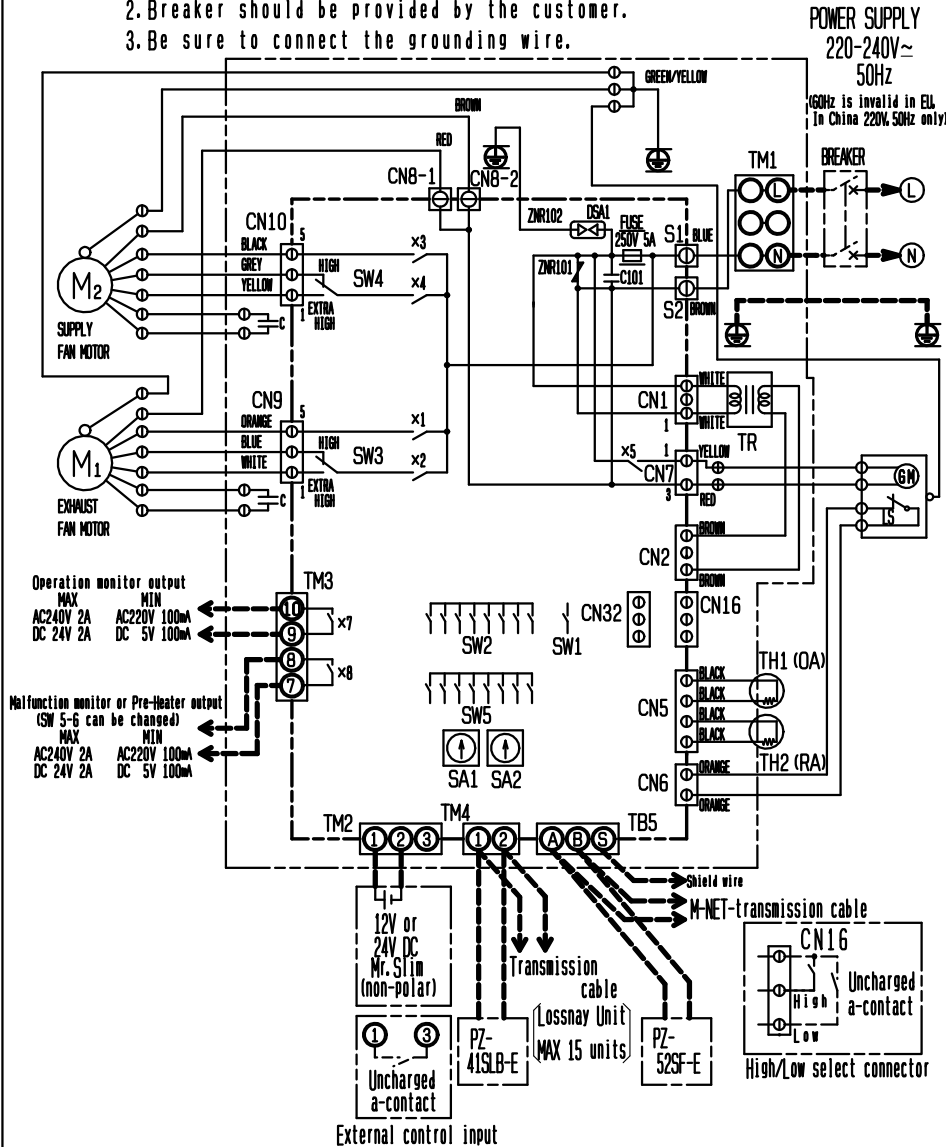

- M1 :Motor for exhaust fan
- M2 :Motor for supply fan
- C :Capacitor
- GM :Motor for Bypass movement
- LS :Microswitch
- TH1:Thermistor for outside air
- TH2:Thermistor for return air
- SW1:Switch(Main/sub change)
- SW2,5:Switch(Function selection)
- SW3:High/E,high select switch (Exhaust fan)
- SW4:High/E,high select switch (Supply fan)
- TM1:Terminal block(Power supply)
- TM2:Terminal block (Transmission cable and external control input)
- TM3:Terminal block(Monitor output)
- ※1TB5:Terminal block (M-NET Transmission cable)
- S1, S2:Connector (Power supply)
- TR:Control circuit transformer
- X7 :Relay contact (For operation monitor output)
- X8 :Relay contact (For malfunction monitor output)
- CN1:Connector(Transformer primary)
- CN2:Connector(Transformer secondary)
- CN5:Connector(Thermistor)
- CN6:Connector(Microswitch)
- CN7:Connector(Motor for Bypass operation)
- CN8-1:Tab connector (Fan motor)
- CN8-2:Tab connector (Fan motor)
- CN9:Connector (Fan motor)
- CN10:Connector (Fan motor)
- CN16:Connector (High/Low switch)
- CN32:Connector (Remote control selection)
- ※1SA1:Address setting rotary switch (10 digit)
- ※1SA2:Address setting rotary switch (1 digit)

※ Attention

1. This must be used with Mitsubishi Electric Air-Conditioner Network System. (MELANS)
2. External control input (TM2) is impossible to use on the Lossnay addressed to "Sub" (SW1) unit.
3. PZ-41SLB-E and PZ-52SF-E cannot be used simultaneously.

MARK

- ⊙:Indicates terminal block.
- :Cconnector.
- ⊞:Board insertion connector or fastening connector of control board.

※Specifications may be subject to change without notice.

WIRING DIAGRAM	DATE	TYPE MODEL	CEILING RECESSED LOSSNAY	
	15-Nov.-04			LGH-50RX4-E
MITSUBISHI ELECTRIC CORPORATION		NUMBER	ND104357A	3/5

Lossnay model selection advices

1. Operating environment
For effective operating environment, refer to corresponding model's specification sheet of indoor and outdoor condition.
2. Do not use under high temperature and humidity condition
Condensation will occur and water will gather inside the Lossnay cores under high temperature and humidity condition, such as warm swimming pool, bathroom, greenhouse or foggy place.
3. Condition of outdoor, indoor and return air
Avoid using Lossnay under air condition with acid, alkalis, organic solvent, oil mist, paint, or harmful gas as pesticide, corrosive gas, etc.
4. Insulation failure caused by brine and hot spring steam
Rust, fire or malfunction may occur.
Installing Brine Damage Resistant Filters inside outdoor air duct if the Lossnay operates in the briny air.
5. Sucking of mist or outdoor air during off-mode operation
Outdoor air or mist may flow through the duct into your room when Lossnay is in off-mode at windy and foggy area.
To prevent sucking of outdoor air or fog, electric damper is advised to be installed.
6. Entry of insects
Insect Resistant Part (optional parts) is recommended to install if the air inlet is at where insects often gather.
7. Usage of M-NET.
When solely using Lossnay units, power supply unit is required to connect to centralized control.
Number of power supply units or the transmission boosters should correspond with the connected Lossnay units.

Caution for installation

1. Do not alter the unit on site as it may cause malfunction.
2. Leaving sufficient space for maintenance purpose.
3. The location of the air inlet
Take care in locating air inlet to prevent sucking of dirty air or disgusting smell from exhaust gas of factory, air from rubbish disposal, etc.
4. Heat insulation foam for duct
Take care as below to prevent the contaminate ceiling by duct condensation.
 - ① Must put insulation foam for both of OA and EA ducts.
 - ② It is possible to occur condensation on SA and RA ducts by some air condition above ceiling. In this case, make sure to put insulation foam indoor side ducts.
 - ③ Outdoor air may come into unit during not operating unit by the pressure difference between indoor and outdoor or the outdoor wind. In this case, should be used electric dumper.
 - ④ It is possible to occur the condensation and freezing in the cold region inside the unit by outdoor air condition or humidity condition above ceiling, even if in the operating environment under this condition, make sure to install supplemental insulation foam.
 - ⑤ In the case that air condition around Lossnay unit is high temperature in summer, it is recommended that there are heat insulation foam on indoor side duct to prevent heat recovery decreased by warming indoor duct.
In winter, it is possible to cool indoor side duct without heat insulation foam on indoor side duct.

*Specifications may be subject to change without notice.

SAFTY NOTES	DATE	TYPE MODEL	CEILING RECESSED LOSSNAY	
	15-Nov.-04		LGH-50RX4-E	(50Hz)
 MITSUBISHI ELECTRIC CORPORATION		NUMBER	ND104357A	4/5

5. Prevent entry of rainwater into Lossnay unit

Using deep-type hood or "Weather cover" instead of using grill or round-shape hood at OA inlet & EA outlet.
It can prevent rainwater pouring directly into Lossnay unit.
Ducts to outdoor (OA and EA) should tilt downward by not lower than 1/30.

6. Caution for the unit with deodorizer

It is possible that deodorized function is not sufficient in the case that ceiling position is high over 3m, or length between odor development and unit position is long.
Make deodorizing before spreading odor, making air flow odor development to unit with air conditioner or subsidial fan.

7. Electrical Work

A ground fault circuit breaker must be installed at the origins of mains power supply.
Use metal switch box, to support control switch or remote control switch.
Must connect ground wiring.

8. Pre-Heat unit

- Make sure to install Pre-Heat unit where Outdoor air temperature is below -10 degree C, or condensation is expected to form. If condensation occurs, water may fall in drops to the room or ceiling.
- Pre-Heat unit must be installed from Lossnay unit as far as possible, because of fire prevention.
- Pre-Heat unit capacity should be less than 1.0kW.
- Install the relay which have rating less than Pre-Heat unit input rating, between Pre-Heate and Lossnay Pre-Heater output terminal.
- Refer to installation manual for further wiring information.
- Make inquire with competent authorities in your region about availability of using Pre-Heat unit and follow an instruction by them before installing the unit.

Caution to use Lossnay unit

Standard tipe Lossnay unit should be controlled by PCB, and should not run "bypass ventilation" when heat mode is in operation in winter.
Otherwise, condensation will occur on unit casing and contaminate ceiling plate.
"Bypass mode setting" will automatically change to Lossnay mode when it is under PCB control while outdoor air is below 8 degree C.
But, please mind that remort controller will not show such changes.

Maintenance

Refer to each model's operation instructions for the suggested maintenance period and methods.
General indication of lifetime of the main parts is as below.
Time below is unrelated to guaranteed period for service. And parts exchange period varies with usage condition.

Lossnay cores	: around 10 years with maintenance as stated periods.
Air Filters	: around 5 years with maintenance as stated periods
High efficiency filters	: 3000 hours
Motor	: 30000 hours

*Specifications may be subject to change without notice.

SAFTY NOTES	DATE	TYPE MODEL	CEILING RECESSED LOSSNAY	
	15-Nov.-04		LGH-50RX ₄ -E (50Hz)	
 MITSUBISHI ELECTRIC CORPORATION		NUMBER	ND104357A	5/5