

## Contents

1. Safety Precautions .....	1
2. Functions .....	2
3. Part names .....	3
4. Functions usually used .....	4
4-1. Operation condition monitor .....	4
(1) Monitoring by group .....	4
(2) Monitoring by group (Shrink display mode) .....	5
(3) Whole building monitor .....	6
4-2. Controlling operations .....	7
(1) Single group operations .....	8
(2) Plural group operation .....	12
(3) Entire floor and whole building operations .....	18
4-3. Schedule operations .....	23
4-3-1. Setting up weekly schedules .....	24
(1) Setting up one-day schedule patterns (day-schedules) .....	24
(2) Setting up weekly schedules .....	30
4-3-2. Setting up exception-day schedules .....	32
(1) Moving across to the exception-day schedule set-up screen .....	32
(2) Date setting .....	33
(3) Day-schedule selection .....	34
4-3-3. Setting up the OFF timer .....	35
(1) Moving across to the OFF timer set-up screen .....	35
(2) Time setting .....	36
5. Malfunction monitor .....	37
(1) Moving across to the malfunction monitoring screen .....	37
(2) Display and operation methods .....	38
6. Operations when filter signs are triggered .....	39
(1) Moving across to The Filter Sign Monitoring Screen .....	39
(2) Display and operation methods .....	40
7. Modifying all kinds of setting and monitoring the previous records .....	41
7-1. Setting the current date and time .....	41
(1) Moving across to the date/time alignment screen .....	41
(2) Setting the current date .....	42
(3) Setting the current date .....	42
7-2. Touch panel adjustments .....	43
(1) Moving across to the touch panel adjustment screen .....	43
(2) Touch panel adjustments .....	43
7-3. Setting the operation prohibited item for remote controllers .....	44
(1) Moving across to the prohibited screen .....	44
(2) Selecting the items to be prohibited .....	45
7-4. Layout modifications .....	46
(1) Moving across to the layout setting screen .....	46
(2) Names of The Layout Setting Screen fields .....	47
(3) Moving group buttons .....	48
(4) Amending the size of group buttons .....	48
(5) Amending group button names .....	48
(6) Adding marks .....	49
(7) Deleting marks .....	49
(8) Moving marks .....	49
(9) Amending the size of marks .....	49
(10) Adding lines .....	50
(11) Deleting lines .....	50
(12) Moving lines .....	50
(13) Amending the length of lines .....	50
7-5. Malfunction log display .....	51
(1) Moving across to the malfunction log screen .....	51
(2) Display and operation methods .....	52
8. Troubleshooting .....	53
8-1. When the screen becomes soiled .....	53
8-2. During power cuts .....	54
9. Specifications .....	55
10. List of error codes .....	56



Read this manual carefully before attempting to operate the equipment.

Retain this manual for future reference

Please see the Instruction Book (Initial Settings and Amending Settings) concerning methods for making settings before starting operation.

# 1. Safety Precautions

- Read this section on safety precautions thoroughly before attempting to operate the equipment to ensure correct usage.
- The hazards inherent with misuse of this equipment have been categorized by the level of danger prevalent as follows.

 <b>WARNING:</b>	Misuse of the equipment may result in death or serious injury.
 <b>CAUTION:</b>	Misuse of the equipment may result in injury or damage to property.

- Ensure that this manual is retained safely in an easily accessible location together with the installation manual after reading. Also, ensure that all subsequent personnel involved with the operation of the equipment have read this manual and the installation manual prior to use.

## **WARNING**

<b>Not to be installed by the customer</b> Request your dealer or any other specialist to perform all installation work. Installation by the customer may result in defective connections, leading to electric shocks or fire.	<b>Not to be moved by the customer</b> Removal by the customer may result in defective connections, leading to electric shocks or fire. Request your dealer or any other specialist to perform all removal work.
<b>Confirm that installation has been performed correctly.</b> Confirm that the equipment has been firmly fixed in place to avoid it falling or toppling over.	<b>Not to be disposed of by the customer.</b> Contact your dealer when the equipment is to be disposed of.
<b>Confirm that a rated power supply is available.</b> Failure to observe this may result in fire or damage to the equipment.	<b>Never remodel or repair the equipment.</b> Remodeling and repairs by the customer may result in defective connections, leading to electric shocks or fire. Request your dealer or any other specialist to perform all repair work.
<b>Halt operations during abnormalities.</b> Failure to halt operations during abnormalities may result in damage to the equipment, electric shocks or fire. In the event of an abnormality (smell of burning, etc.) halt operations, cut off the power supply and contact your dealer.	<b>Halt operations during error displays and defective operations</b> Failure to halt operations may result in fire or damage to the equipment. Contact your dealer in this event.

This product complies with the EN50081-1 and EN50082-1 Generic standards, and EN50090-2 of the Home and Building Electronic Systems standards has not been considered. In other words, the immunity level only applies to the levels stipulated by the Generic standards. It is necessary to confirm that class A equipment, ISM equipment and other equipment fitted with strong electromagnetic output sources do not exist in the immediate vicinity of the product during installation. If there is no choice other than operating the product in an environment containing strong electromagnetic field, contact the manufacturer in order to set up applicable protection devices.

## **CAUTION**

<b>Do not place hazardous materials near the equipment</b> Do not install the equipment in locations where there is the risk of flammable gas leaks. Failure to observe this may result in the outbreak of fire or explosions.	<b>Do not use with specialized equipment</b> The use of the equipment in locations containing high levels of oil (including mechanical grease), vapor or sulfurized gas may result in a remarkable deterioration of functions or damaged parts. Defective connections may also result in electric shocks and fire.
<b>Do not clean the equipment with water</b> <b>Do not touch the screen with wet hands</b> Failure to observe this may result in electric shocks or damage to the equipment.	<b>Do not touch the screen with pointed objects</b> Failure to observe this may result in electric shocks or damage to the equipment.
<b>Do not apply too much pressure to the screen</b> Failure to observe this may result in electric shocks or damage to the equipment.	<b>Do not use outside of the permissible temperature ranges</b> Ensure that the permissible temperature range is closely observed. Use of this equipment in an environment outside of the permissible temperature range may result in severe damage to the equipment. Check the permissible temperature range in the specifications outlined in the instruction manual. The permissible temperature range is between 0 degrees and 40 degrees Celsius in the event that a temperature range is not stipulated.
<b>Do not use the equipment for non-stipulated purposes</b> This equipment is the Mitsubishi Building Air Conditioner Control System. Never use it to control other air conditioning systems or for any other application. Failure to observe this may result in malfunctions.	<b>Do not dismantle the equipment</b> In addition to being hazardous, removing internal substrates may result in fire or damage to the equipment.
<b>Do not allow fumigation agents or other flammable sprays to come into contact with the equipment</b> Do not place flammable sprays near to the equipment, or directly spray flammable agents onto the equipment. Failure to observe this may result in the outbreak of fire or explosions.	
<b>Do not wipe the equipment with benzene, thinner or chemically treated cloths</b> Failure to observe this may result in discoloring or damage to the equipment. When soiling is severe, moisten a cloth with a medium-strength cleaning agent diluted with water, allow the cloth to dry and then wipe the equipment. After this, ensure that the same area is wiped thoroughly with a dry cloth.	

## 2. Functions

		Function	Details	
Number of control units		Indoor units, LOSSNAY	Up to 100 units can be connected with the standard configuration. This can be increased to 200 units by expanding the GWU-50A to two units.	
		Number of indoor units per group	1 to 16 (The same applies for independent LOSSNAY (OA processing unit). However, indoor units and LOSSNAY cannot be used in the same group.)	
		Number of remote-controllers per group	0 to 2	
		System controllers per group	0 to 4. (However, ensure that the total number of remote controllers and system controllers in each group is four or less.)	
Normal functions	Operations	ON/OFF	The system can be operated and stopped for the whole building, an entire floor or by group. (Bulk operations can also be performed for only indoor units or LOSSNAYs)	
		Temperature setting	Room temperature can be set for the whole building, and entire floor or by group. Permissible temperature range. During cooling (dry) 19 °C to 30 °C. During heating 17 °C to 28 °C. During automatic operations 19 °C to 28 °C.	
		Operation modes	Mode switching is possible between Cool, Dry, fan, Heat and Auto for the whole building, an entire floor or by group. (Switching between Bypass, Heat recovery and Auto ventilation is possible with LOSSNAY groups.)	
		Air direction setting	Possible to switch between four vertical stages or swing by group.	
		Fan speed	Possible to switch between four levels by group. (Two levels depending on the type)	
		Prohibit local remote controller	It is possible to prohibit and permit the specific functions of remote controllers for the whole building, an entire floor or by group (The prohibiting setting is performed on a different screen. The only operations that can be prohibited are ON/OFF, Operation mode, Temperature, Filter sign reset.)	
		Filter sign reset	The filter sign display can be reset for the whole building, an entire floor or by group.	
		External signal input interface	It is possible to set the emergency stop, ON/OFF and prohibit/permit all together from an external source.	
	Monitoring	ON/OFF (bulk)	It is possible to display the ON/OFF status for an entire floor (all on, all off, some on/some off)	
		Operating status (by floor)	It is possible to display the ON/OFF status, the schedule valid/invalid status and the malfunction/filter sign status graphically by group for each floor.	
		Operating status (by group)	It is possible to display the ON/OFF status, the temperature settings, the operation mode, the air direction, the fan speed, the remote control prohibited/permits status and the filter sign status by group.	
		Error (bulk)	It is possible to display the unit for which an error has been triggered from amongst all units.	
		Filter sign (bulk)	It is possible to display the unit for which a filter sign has been triggered from amongst all units.	
	Schedule	OFF timer	Switches the units off at the time preset for that day for the whole building, an entire floor or by group.	
		Weekly schedule	It is possible to set the weekly operating schedule for the whole building, an entire floor or by group. It is possible to set the schedule pattern (daily schedule) allocated every Sunday as follows: #Twelve different schedule patterns for the entire system. #Six different settings per day for ON/OFF, temperature setting, operating mode and remote control prohibit/permit with each schedule pattern.	
		Exception-day schedule	It is possible to set fifty days of exceptional schedule operations (national holidays, etc.) for one year in units of the whole building, an entire floor and groups. The schedule pattern (day schedule) for assigning each date is the same schedule pattern as assigned to the weekly schedule.	
	Maintenance functions	Settings	Current time setting	It is possible to set the current date and time.
			Display layout setting	It is possible to set the display layout and group name for the group button on each floor.
			Touch panel adjustment	Adjusts the touch panel.
			Prohibit items setting	It is possible to prohibit operations from remote controllers for the whole building, an entire floor or by group (the items that can be prohibited are ON/OFF, Operation mode, Temperature setting and Filter sign reset.)
		Monitoring	Monitoring past malfunctions	Displays a maximum of 200 past malfunctions (200 from the most recent)
System settings	Connection information setting	Registers indoor units, LOSSNAYs, remote controllers and slave system controllers.		
Others	Data backup	Current time back up	The current date and time is backed up in the internal condenser for a period of approximately one week after the mains power has been cut off. (The power supply to the main system must be switched on continuously for 24 hours or more to recharge the internal condenser)	
		Schedule	Saves the contents of the pre-set schedule even when the mains power is switched off.	
		Display layout	Saves the contents of the pre-set display layout even when the mains power is switched off.	
		Operations prohibited	Saves the contents of the operations prohibited item even when the mains power is switched off.	
		Malfunction log	Saves the contents of the Malfunction log even when the mains power is switched off.	
		Connection information	Saves the contents of the pre-set connection information even when the mains power is switched off.	
	External input/output	External input	It is possible to set the emergency stop/normal operations mode, the ON/OFF and the remote control prohibit/permit with a no-voltage contact signal input.	
		External output	The "ON" signal is output when one or more of the units being controlled are operating. The "Malfunction" signal is output when a malfunction occurs in one or more of the units being controlled.	

### 3. Part names

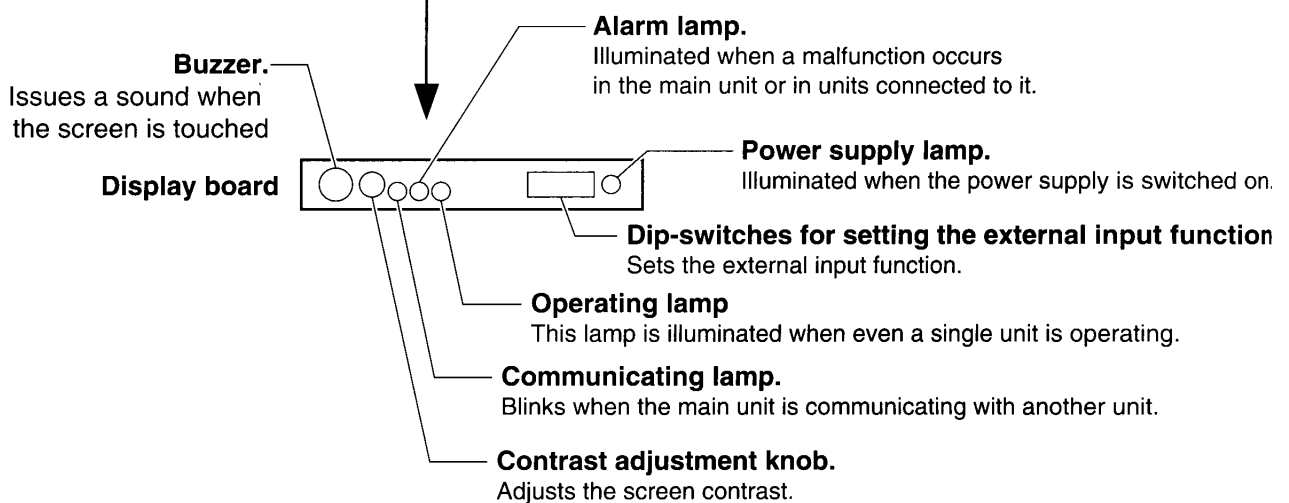
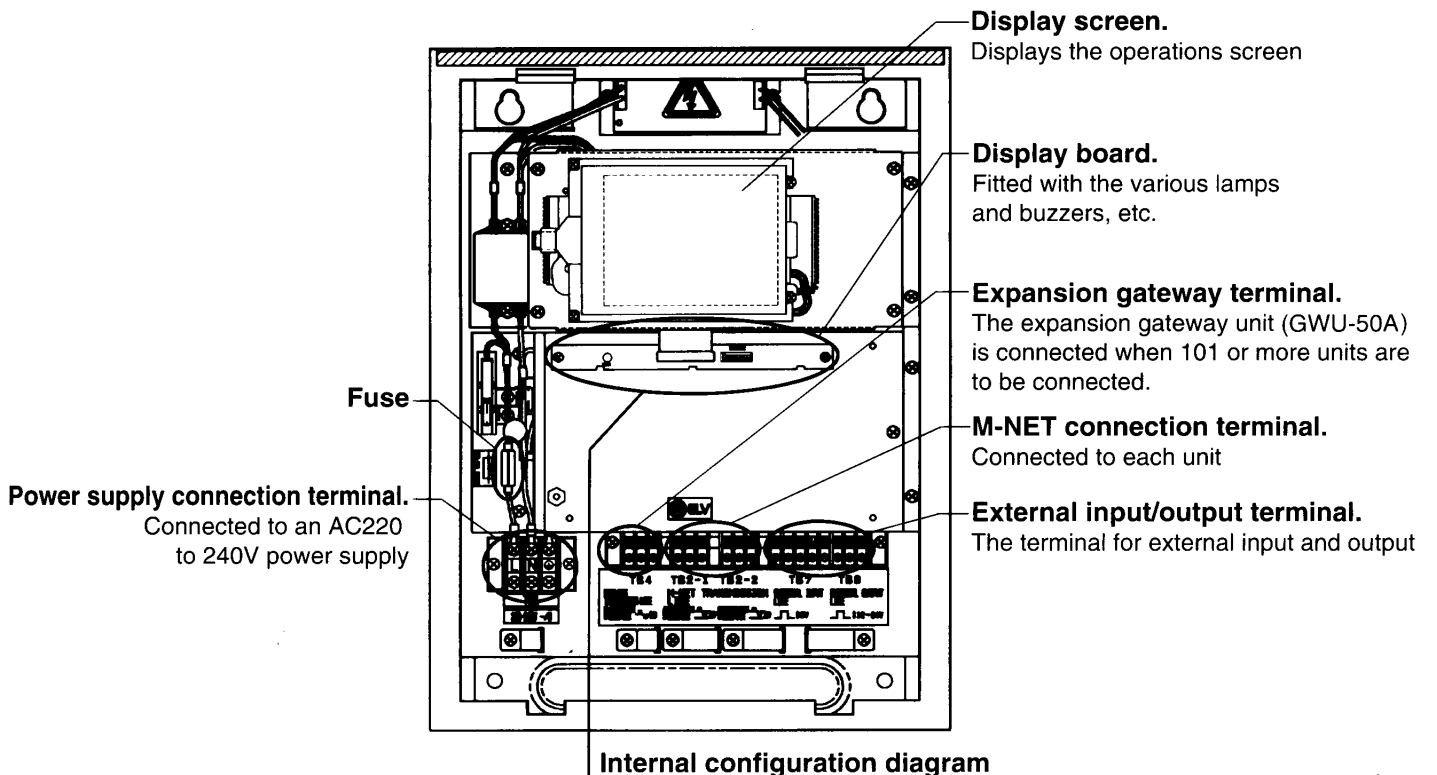
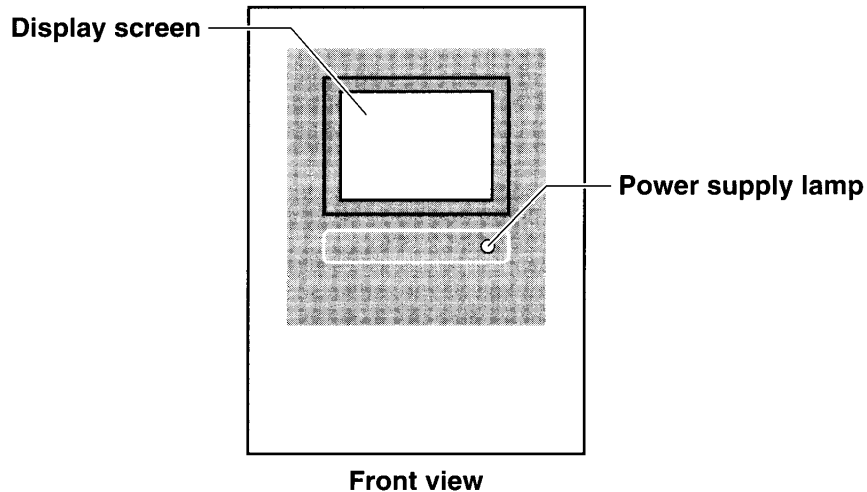

**NOTE:** ● The settings for the display board have already been made by a specialist. The customer must not amend these settings.



# 4. Functions usually used

## 4-1. Operation condition monitor

### (1) Monitoring by group

- The condition of air conditioner (indoor unit) or Lossnay (OA processing unit) can be monitored by group to provide any display during ON/OFF/Malfunction Status/Filter sign occurrence.
- A schedule mark will be attached to the group button when weekly schedule, exception-day schedule or OFF Timer has been set up.

The Operation Condition Monitoring Screen.

**Group button display area.**  
Displays the groups installed on the floor.

**Scroll buttons.**  
Scrolls the screen up, down, left and right.

**Enlarge/Shrink button.**  
Switches between the normal display, a shrunken display and a display of the whole building.

**Filter button.**  
Displayed when a filter sign has been triggered for one or more units.

**+α button.**  
Moves to all kinds of setting and record screens. (-->P.41--)

**Error button.**  
Displayed when a malfunction occurs for one or more units.

**UP button.**  
Displays the next upper floor.

**Displayed floor.**  
The floor number is being displayed.

**Down button.**  
Displays the next lower floor.

**Group button**

**Picture of the operation status.**  
Displays a picture of the operation status for the set-up type

**Group name.**  
Displays the group name.

**NOTE:** ● The pictures for the operation status are displayed as follows.

Air-conditioner	ON	ON (schedule available)	ON (OFF timer available)
	OFF	OFF (schedule available)	OFF (OFF timer available)
LOSSNAY	ON	ON (schedule available)	ON (OFF timer available)
	OFF	OFF (schedule available)	OFF (OFF timer available)



● An X mark or F mark lights up on the group button if a malfunction or filter sign occurs.

Malfunction triggered    Filter sign triggered

**NOTE:** ● The backlight will be extinguished and the screen will return to the operation condition monitoring screen when no operation is made on normal operation screens for a period of ten minutes. (During a malfunction, the backlight does not go off.) Touch the screen once to re-illuminate the backlight in this case.

● If the external input function is used, and ON/OFF operation or manual operation Prohibited/Permitted is input from an external system, the ON/OFF operation or Prohibited/Permitted setting applies to all units. (Please refer to p. 5 of the Instruction Book, "Initial Settings and Amending Settings".)

## (2) Monitoring by group (Shrink display mode)

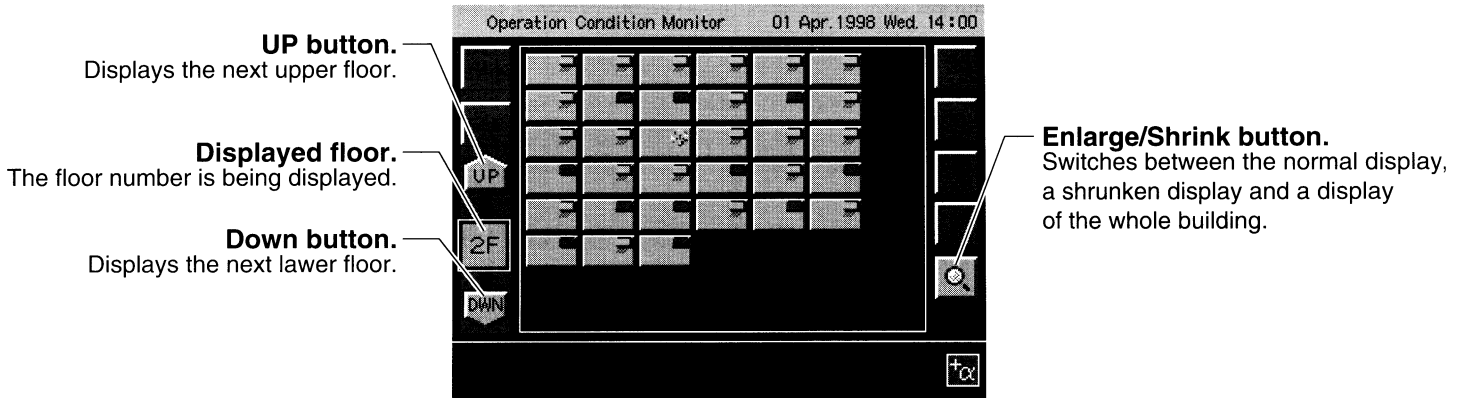

- Touch the  button on the operation condition monitoring screen to reduce the size of the screen displayed.
- Touch the  button twice to return to the operation condition monitoring screen. (The display will switch sequentially through [Normal display] → [Shrink display] → [Whole building display] whenever the  button is touched.)

The Operation Condition Monitoring Screen. (Shrink display mode)



**NOTE:** ● With the exception of the UP button, Down button and Enlarge/Shrink button, no other buttons can be pressed on this screen. Touch the Enlarge/Shrink button twice to return to the operation condition monitoring screen if other operations are required.

### (3) Whole building monitor

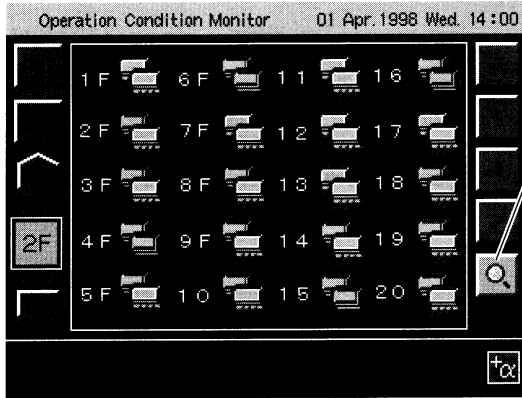

- Touch the  button on the operation condition monitoring screen (Shrink display mode) to switch across to a display of the whole building.
- This screen displays the operating condition of the units on all floors, and the [All ON/All OFF/Some ON some OFF] display.
- Touch the  button once to return to the operation condition monitoring screen. (The display will switch sequentially through [Normal display] → [Shrink display] → [Whole Building display] whenever the  button is touched.)

The Operation Condition Monitoring Screen. (Whole Bldg mode)



**Enlarge/Shrink button.**

Switches between the normal display, a shrunken display and a display of the whole building.

- NOTE:**
- With the exception of the Enlarge/Shrink button, no other buttons can be pressed on this screen. Touch the Enlarge/Shrink button once to return to the condition status monitoring screen if other operations are required.
  - The pictures for each operation status are as follows.
    -  1. All units on this floor are in operation
    -  2. All units on this floor are halted
    -  3. Some units are operating and some are halted on this floor

## 4-2. Controlling operations

- Controls operations by group, by floor and for the whole building.
- It is possible to monitor the present operation status by selecting a single group.
- Refer to the following pages for details on actual operations.

- (1) Single group operations
  - (1-1) Air-conditioner groups → p.9
  - (1-2) LOSSNAY groups → p.11
- (2) Multiple group operation
  - (2-1) Air-conditioner groups → p.13
  - (2-2) LOSSNAY groups → p.15
  - (2-3) Air-conditioner and LOSSNAY groups → p.17
- (3) Entire floor and whole building operations
  - (2-1) Air-conditioner groups → p.19
  - (2-2) LOSSNAY groups → p.21
  - (2-3) Air-conditioner and LOSSNAY groups → p.22

- The names of all fields on the operation condition monitoring screen and the operations control screen are as follows.

**The Operation Condition Monitoring Screen.**

**ALL button.**  
Controls the whole building.

**FLR button.**  
Controls an entire floor.

**Group button display area.**  
Displays the groups installed on the floor.

**Scroll buttons.**  
Scrolls the screen up, down, left and right.

**Group button.**  
Touch this button to select single groups.

**Operation button.**  
Displayed when a group has been selected.  
Touch this button to move across to the operation control screen.

**The Operation Control Screen.**

**Set-up target.**  
Displays the target for set-up.

**Operations control area.**  
Sets the various parameters for operations.

**Cancel button.**  
Cancels the settings and returns to the operation condition monitoring screen.

**OK button.**  
Registers the settings and returns to the operation condition monitoring screen.

# (1) Single group operations

- The current operation status will be displayed when entering the operations control screen. Controls the operation status for each group of air-conditioners or LOSSNAY units.
- Refer to the following pages for details on operating The Operations Control Screen.
  - (1-2) Air-conditioning groups → p.9
  - (1-3) LOSSNAY groups → p.11
- Move across to the operations control screen by observing the following procedure.

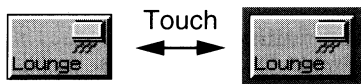

Not selected

Selected

The Operation Condition Monitoring Screen.

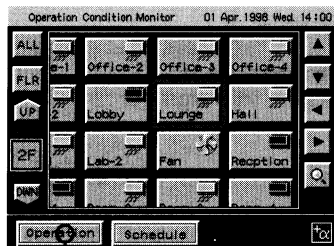

The Operation Control Screen.

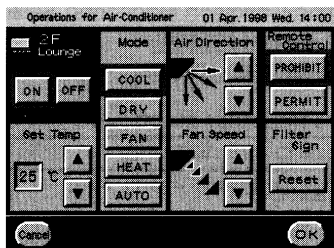

- ① Touch the group button for which operations are required on the operations condition monitoring screen. The button will be framed to indicate it has been selected when touched.

To cancel the selection:

Touch the group button for the items selected to cancel the selection.







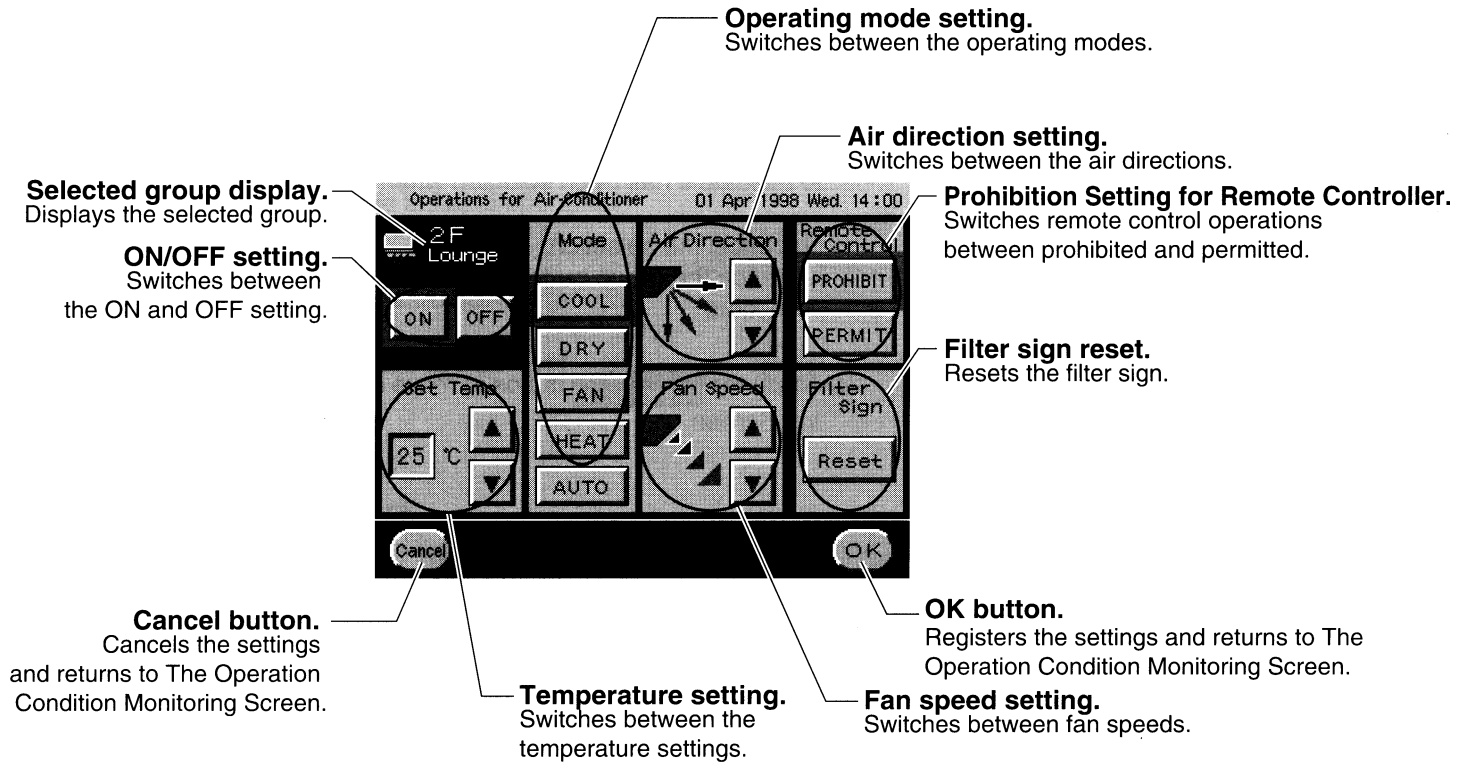

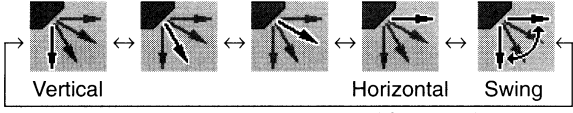
- ② Touch the **Operation** button to move across to The Operation Control Screen.

## (1-1) Single group operations (Air-conditioning groups)

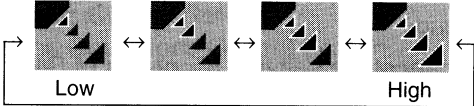
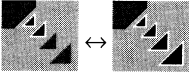



- Touch the **OK** button after the operation settings have been made to switch across to the operations status for the selected group.
- If you desire to cancel the settings (Contents of Settings), touch the **Cancel** button.



Function	Operations
ON/OFF setting	Touch either the <b>ON</b> or <b>OFF</b> buttons to switch the groups ON and OFF.
Temperature setting	Touch the <b>▲</b> and <b>▼</b> buttons to set the temperature setting. COOL/DRY operations : 19 to 30 °C HEAT operations : 17 to 28 °C AUTO operations : 19 to 28 °C (Not set during FAN operations)
Operating mode setting	Touch any of the buttons between <b>COOL</b> and <b>AUTO</b> to switch between operating modes for the selected group. Selection of the <b>AUTO</b> button is not possible for models not equipped with the automatic mode.
Air direction setting	Touch the <b>▲</b> and <b>▼</b> buttons to set the air direction for the selected group.  (The air direction area will not be displayed for models not equipped with an air direction switching function. The swing will not be displayed for models not equipped with a swing function.)

Function	Operations
Fan speed setting	<p>Touch the  and  buttons to set the fan speed for the selected group.</p> <p>Four-level fan speed types: </p> <p>Two-level fan speed types: </p> <p>The fan speed setting area will not be displayed for models not equipped with a fan speed switching function.</p>
Prohibition Setting For Remote Controller	<p>Touch the  or  buttons to prohibit or permit specific function of the remote controller for the selected group. The items that can be prohibited when  has been selected (ON/OFF, Operating mode, Temperature and Filter sign reset) are set on The Screen For Selecting The Required Units (→ p.44).</p>
Filter sign reset	<p>Touch the  button to reset the filter sign for the selected group. (This field will be displayed darkly when a filter sign has not been triggered, and it will not be possible to select the  button.)</p>

**NOTE:** ● The items that cannot be operated will be displayed in a darker color, and it will not be possible to operate the operation buttons.

- ① If touch the  button on the ON/OFF settings, the [Temperature Settings], [Operation Mode Settings], [Air Direction Settings], [Fan speed Settings] and [Filter sign reset] cannot be set.
- ② If touch the  button on the operation mode settings, the [Temperature Settings] cannot be set.
- ③  button cannot be selected with indoor unit models without the automatic mode.
- ④ If no Prohibited item (→ p. 44) is set, the  button cannot be selected.

- The air direction switching area will not be displayed for indoor unit models not equipped with an air direction switching function.
- The fan speed switching area will not be displayed for indoor unit models not equipped with a fan speed switching function.
- [Swing] settings are not possible with indoor unit models not equipped with a swing function.
- If the A-control indoor unit is stopping and the only interlocked OA processing unit is operating, the  button is selected on this screen.

## (1-2) Single group operations (LOSSNAY groups)

- Touch the **OK** button after the operation settings have been made to switch across to the operations status for the selected group.
- If you desire to cancel the settings (Contents of Settings), touch the **Cancel** button.

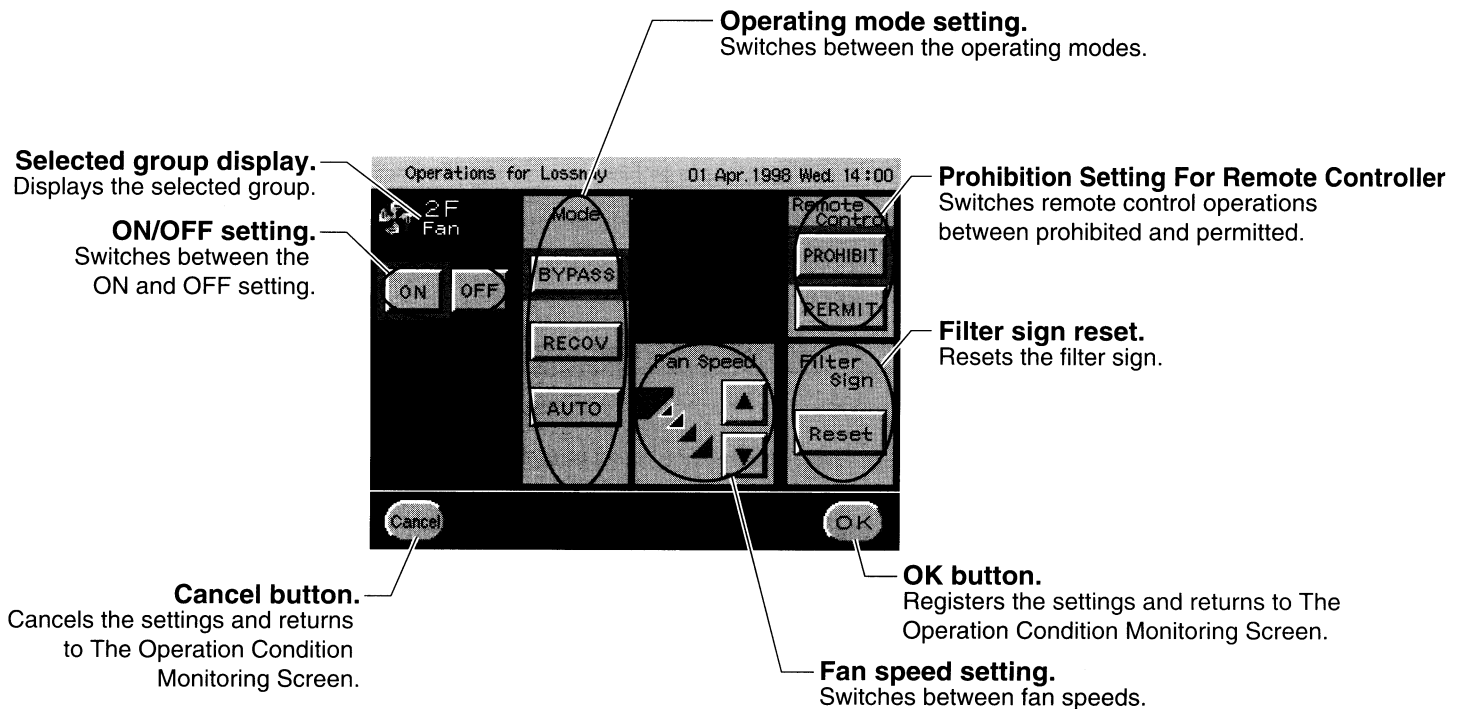

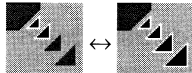
Function	Operations
ON/OFF setting	Touch either the <b>ON</b> or <b>OFF</b> buttons to switch the groups ON and OFF.
Operating mode setting	Touch any of the <b>BYPASS</b> , <b>RECOV</b> and <b>AUTO</b> buttons to switch between operating modes for the selected group.
Fan speed setting	Touch the <b>▲</b> and <b>▼</b> buttons to set the fan speed for the selected group.  Two-level fan speed types:   The fan speed setting area will not be displayed for models not equipped with a fan speed switching function.
Prohibition Setting For Remote Controller	Touch the <b>PROHIBIT</b> or <b>PERMIT</b> buttons to prohibit or permit specific function of the remote controller for the selected group. The items that can be prohibited when <b>PROHIBIT</b> has been selected (ON/OFF, Operating mode, Temperature and Filter sign reset) are set on the prohibited item selected screen (→ p.44).
Filter sign reset	Touch the <b>Reset</b> button to reset the filter sign for the selected group. (This field will be displayed darkly when a filter sign has not been triggered, and it will not be possible to select the <b>Reset</b> button.)

- NOTE:**
- Fields that cannot be operated will be displayed faintly and it will not be possible to select the corresponding button.
    - ① If touch the **OFF** button on the ON/OFF setting, it will not be possible to set the [Operating mode setting], [Fan speed setting] and [Filter sign reset].
    - ② **AUTO** button cannot be selected with LOSSNAY without the automatic mode.
    - ③ If no Prohibited item (→ p. 44) is set, the **PROHIBIT** button cannot be selected.
  - The fan speed switching area will be displayed for indoor unit models not equipped with a fan speed switching function.



## (2) Plural group operation

- Jointly controls the operation status for plural groups of air-conditioners or LOSSNAY units. All settings fields will be displayed as No Setting when entering The Operations Control Screen.
- Refer to the following pages for details on operating The Operations Control Screen.
  - (2-1) Air-conditioning groups → p.13
  - (2-2) LOSSNAY groups → p.15
  - (2-3) Air-conditioning and LOSSNAY groups → p.17
- Move across to The Operations Control Screen by observing the following procedure.

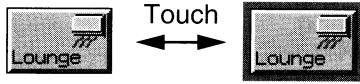

Not selected

Selected

The Operation Condition Monitoring Screen.

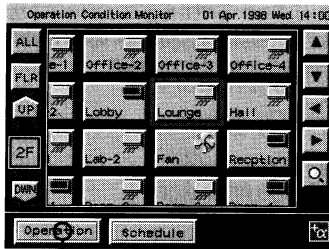

The Operation Control Screen.

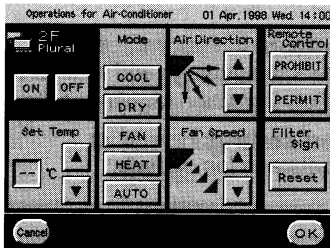



- ① Touch the plural group button for which operations are required on The Operations Condition Monitoring Screen. The button will be framed to indicate it has been selected when touched.

To cancel the selection:

Touch the group button for the items selected to cancel the selection.

- ② Touch the **Operation** button to move across to The Operation Control Screen.









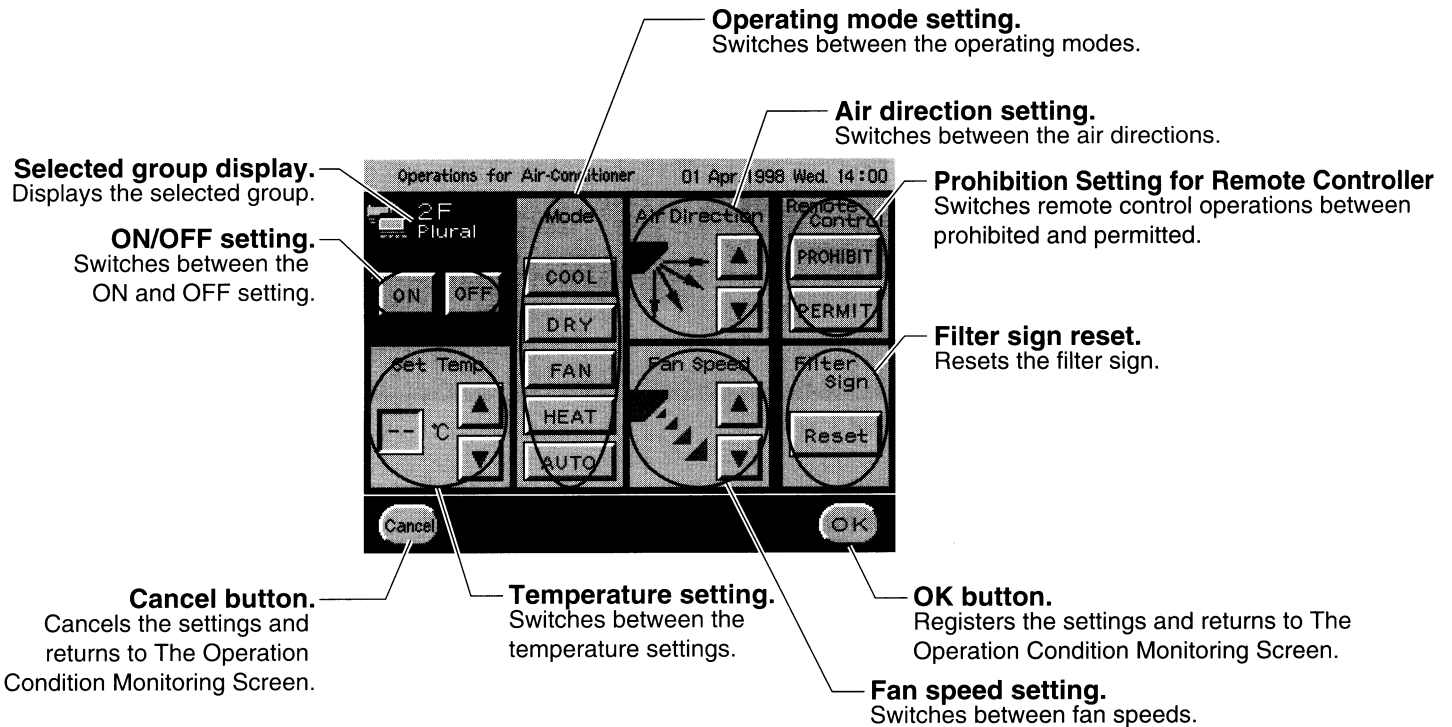

## (2-1) Plural group operations (air-conditioning groups)







- Touch the  button after the operation settings have been made to switch across to the operations status for the selected group.
- If you desire to cancel the settings (Contents of Settings), touch the  button.
- If the operation status of items have not been selected, the previously set conditions remain as they are.

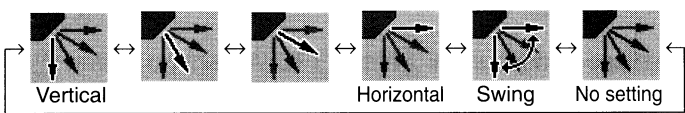

Example: When neither  nor  have been selected:

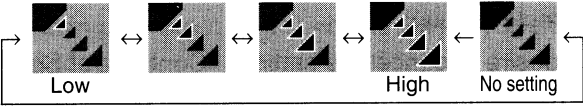
- Operating air-conditioners will continue to operate.
- Halted air-conditioners will remain halted.



Function	Operations
ON/OFF setting	Touch either the  or  buttons to switch the groups ON and OFF. The selection can be canceled by touching the selected button once more, and the setting will be rendered void.
Temperature setting	Touch the  and  buttons to set the temperature. Regardless of the mode, the temperature setting range is 19~28°C. (Not set during FAN operation) The setting can be rendered void by touching the  button when at the upper limit and the  button when at the lower limit. [--] will be displayed when the setting will be rendered void.
Operating mode setting	Touch any of the buttons between  and  to switch between operating modes for the selected group. The selection can be canceled by touching the selected button once more, and the setting will be rendered void.
Air direction setting	Touch the  and  buttons to set the air direction for the selected group.  (The operations will not be reflected for models not equipped with an air direction switching function. The swing operations will not be reflected for models not equipped with a swing function.)

Function	Operations
Fan speed setting	<p>Touch the  and  buttons to set the fan speed for the selected group.</p> <p>Four-level fan speed types: </p>
Prohibition Setting For Remote Controller	<p>Touch the  or  buttons to prohibit or permit specific function of the remote controllers for the selected groups. The selection can be canceled by touching the selected button once more, and the setting will be rendered void. The items that can be prohibited when  has been selected (ON/OFF, Operating mode, Temperature, and Filter sign reset) are set on The Prohibited Item Selected Screen (→ p.44).</p>
Filter sign reset	<p>The filter sign for all selected groups will be reset when  is touched.</p>

- NOTE:**
- Fields that cannot be operated will be displayed darkly and it will not be possible to select the corresponding button.
  - ① If touch the  button on the ON/OFF setting, it will not be possible to set the [Temperature setting], [Operating mode setting], [Air direction setting], [Fan speed setting] and [Filter sign reset].
  - ② If touch the  button on the operating mode setting, it will not be possible to set the [Temperature setting].
  - If models that are not equipped with the automatic mode function are included in the selected group, it will not be possible for automatic setting to be performed on the indoor unit models without the automatic mode even when automatic has been specified.
  - If models that are not equipped with the air direction switching function are included in the selected group, it will not be possible to switch the air direction for the models without the switching function.
  - If models that are not equipped with the swing function are included in the selected group, it will not be possible for the swing settings to be performed on the indoor unit models without the swing function even when swing has been specified.
  - If models that are not equipped with the fan speed switching function are included in the selected group, it will not be possible to switch the fan speed for the indoor unit models without the switching function.

## (2-2) Plural group operations (LOSSNAY groups)

- Touch the **OK** button after the operation settings have been made to switch across to the operations status for the selected groups.
- If you desire to cancel the settings (Contents of Settings), touch the **Cancel** button.
- If the operation status of items have not been selected, the previously set conditions remain as they are.

Example: When neither **ON** nor **OFF** have been selected:

- Operating LOSSNAY units will continue to operate.
- Halted LOSSNAY units will remain halted.

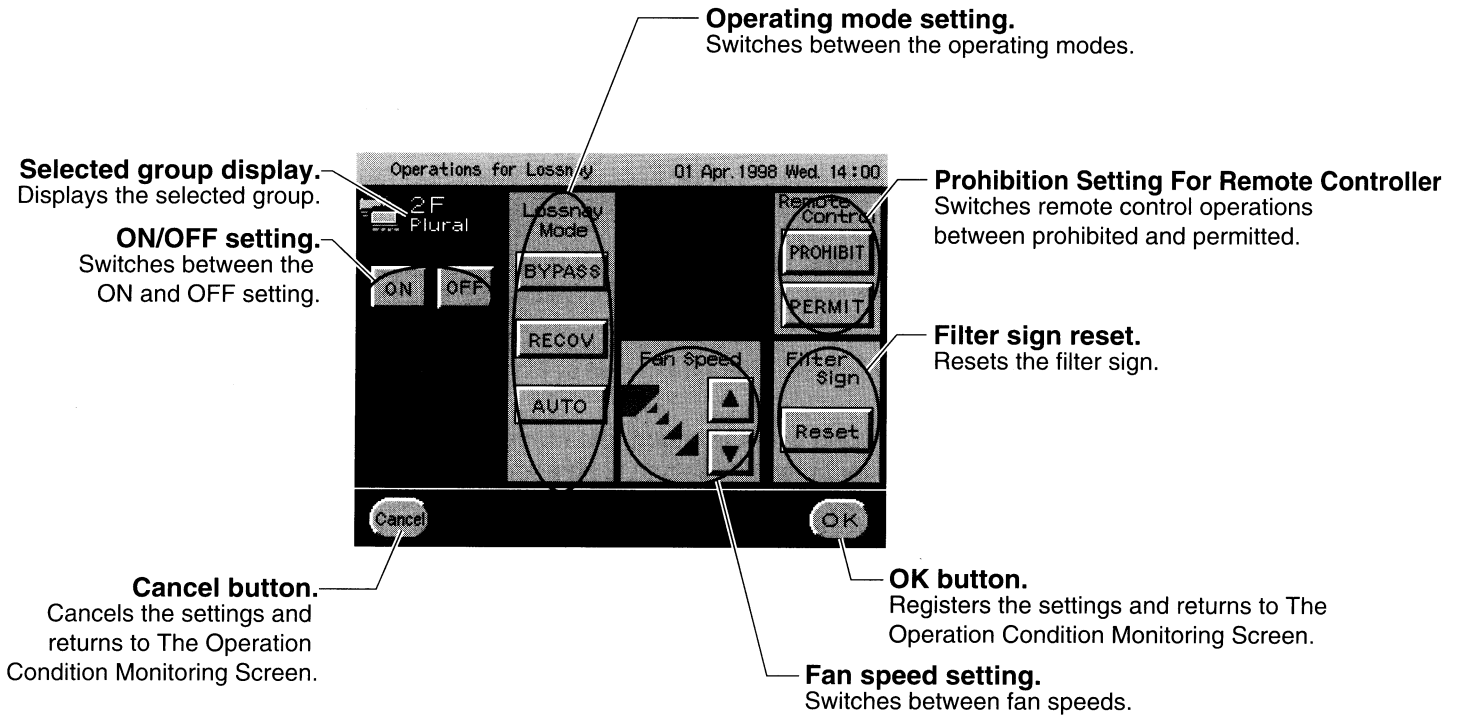

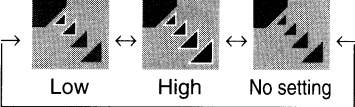
Function	Operations
ON/OFF setting	Touch either the <b>ON</b> or <b>OFF</b> buttons to switch the groups ON and OFF. The selection can be canceled by touching the selected button once more, and the setting will be rendered void.
Operating mode setting	Touch any of the <b>BYPASS</b> , <b>RECOV</b> and <b>AUTO</b> buttons to switch between operating modes for the selected group. The selection can be canceled by touching the selected button once more, and the setting will be rendered void.
Fan speed setting	Touch the <b>▲</b> and <b>▼</b> buttons to set the fan speed for the selected group.  Two-level fan speed types: 
Prohibition Setting For Remote Controller	Touch the <b>PROHIBIT</b> or <b>PERMIT</b> buttons to prohibit or permit specific function of the remote controllers for the selected groups. The selection can be canceled by touching the selected button once more, and the setting will be rendered void. The items that can be prohibited when <b>PROHIBIT</b> has been selected (ON/OFF, Operating mode, Temperature, and Filter sign reset) are set on The Prohibited Item Selected Screen (→ p.44).
Filter sign reset	The filter sign for all selected groups will be reset when <b>Reset</b> is touched.

- NOTE:**
- Fields that cannot be operated will be displayed faintly and it will not be possible to select the corresponding button.
  - ① If touch the  button on the ON/OFF setting, it will not be possible to set the [Operating mode setting], [Fan speed setting] and [Filter sign reset].
  - If models that are not equipped with the fan speed switching function are included in the selected group, it will not be possible to switch the fan speed for the indoor unit models without the switching function.

## (2-3) Plural group operations (air-conditioning and LOSSNAY groups)

- Touch the **OK** button after the operation settings have been made to switch across to the operations status for the selected groups.
- If you desire to cancel the settings (Contents of Settings), touch the **Cancel** button.
- If the operation status of items have not been selected, the previously set conditions remain as they are.

Example: When neither **ON** nor **OFF** have been selected:

- Operating air-conditioners and LOSSNAY units will continue to operate.
- Halted air-conditioners and LOSSNAY units will remain halted.

**Selected group display.**  
Displays the selected group.

**ON/OFF setting.**  
Switches between the ON and OFF setting.

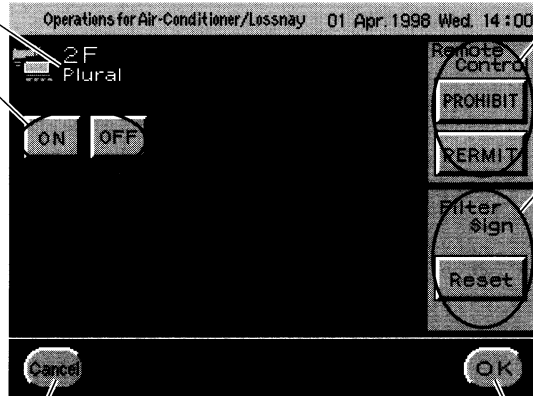

**Prohibition Setting For Remote Controller**  
Switches remote control operations between prohibited and permitted.

**Filter sign reset.**  
Resets the filter sign.

**Cancel button.**  
Cancels the settings and returns to The Operation Condition Monitoring Screen.

**OK button.**  
Registers the settings and returns to The Operation Condition Monitoring Screen.

Function	Operations
ON/OFF setting	Touch either the <b>ON</b> or <b>OFF</b> buttons to switch the groups ON and OFF. The selection can be canceled by touching the selected button once more, and the setting will be rendered void.
Prohibition Setting For Remote Controller	Touch the <b>PROHIBIT</b> or <b>PERMIT</b> buttons to prohibit or permit specific function of the remote controllers for the selected groups. The selection can be canceled by touching the selected button once more, and the setting will be rendered void. The items that can be prohibited when <b>PROHIBIT</b> has been selected (ON/OFF, Operating mode, Temperature, and Filter sign reset) are set on The Prohibited Item Selected Screen (→ p.44).
Filter sign reset	The filter sign for all selected groups will be reset when <b>Reset</b> is touched.

**NOTE:** ● Items which cannot be operated appear dark in the display and their operating buttons do not respond to touch.

① Touch **OFF** at the ON/OFF operation setting.  
The [Filter sign reset] item cannot be operated.

### (3) Entire floor and whole building operations

- Jointly controls the operation status for groups of air-conditioners or LOSSNAY units. All settings fields will be displayed as No Setting when entering The Operations Control Screen.
- Refer to the following pages for details on operating The Operations Control Screen.
  - (3-1) Air-conditioning groups → p.19
  - (3-2) LOSSNAY groups → p.21
  - (3-3) Air-conditioning and LOSSNAY groups → p.22
- Move across to The Operations Control Screen by observing the following procedure.

The Operation Condition Monitoring Screen.

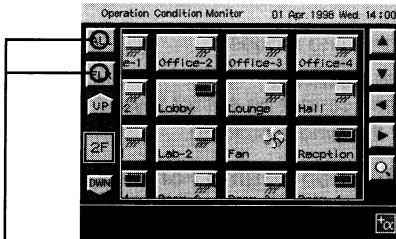

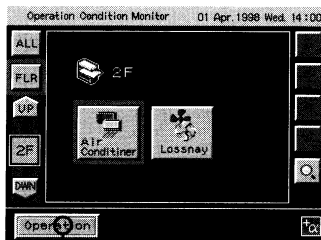

The Type Selection Screen.

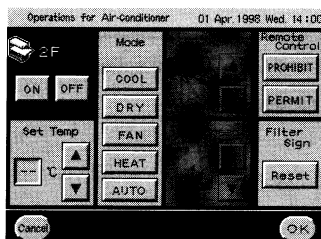

The Operation Control Screen.



- ① Touch the **ALL** button when batch operations for the whole bldg. are required. Touch the **FLR** button when batch operations for an entire floor are required.
- ② Touch the  button on The Type Selection screen to perform the batch settings for all air-conditioners. Touch the  button on The Type Selection Screen to perform the batch settings for all LOSSNAY units. Touch both buttons if settings are required for both air-conditioners and LOSSNAY units.
- ③ Select the required floor with the **UP** and **DWN** buttons when batch operations are required for a particular floor.
- ④ Touch the **Operation** button when the type has been selected to move across to The Operation Control Screen.

**NOTE:** ● The buttons for the models connected will be displayed on the type selection screen.

- ① For air-conditioner only systems:

Only the  button will be displayed.

- ② For systems that include both air-conditioners and LOSSNAY:

The  button and  button will be displayed.

### (3-1) Entire floor and whole building operations (Air-conditioning groups)

- Touch the **OK** button after the operation settings have been made to switch across to the operations status for the selected groups.
- If you desire to cancel the settings (Contents of Settings), touch the **Cancel** button.
- If the operation status of items have not been selected, the previously set conditions remain as they are.

Example: When neither **ON** nor **OFF** have been selected:

- Operating air-conditioners will continue to operate.
- Halted air-conditioners will remain halted.



The screenshot shows a control interface for air conditioning. At the top, it displays 'Operations for Air-Conditioner' and the date/time '01 Apr. 1998 Wed. 14:00'. The screen is divided into several sections:

- Selected group display:** Shows '2F' (2nd floor).
- ON/OFF setting:** Buttons for 'ON' and 'OFF'.
- Temperature setting:** 'Set Temp' section with 'C' (Celsius) and 'F' (Fahrenheit) indicators, and up/down arrow buttons.
- Operating mode setting:** A 'Mode' section with buttons for 'COOL', 'DRY', 'FAN', 'HEAT', and 'AUTO'.
- Prohibition Setting For Remote Controller:** 'Remote Contr' section with 'PROHIBIT' and 'PERMIT' buttons.
- Filter sign reset:** 'Filter Sign' section with a 'Reset' button.
- Cancel button:** A 'Cancel' button at the bottom left.
- OK button:** An 'OK' button at the bottom right.

Callouts provide detailed descriptions for each of these sections, such as 'Operating mode setting. Switches between the operating modes.' and 'Filter sign reset. Resets the filter sign.'

Function	Operations
ON/OFF setting	Touch either the <b>ON</b> or <b>OFF</b> buttons to switch the groups ON and OFF. The selection can be canceled by touching the selected button once more, and the setting will be rendered void.
Temperature setting	Touch the <b>▲</b> and <b>▼</b> buttons to set the temperature. Regardless of the mode, the temperature setting range is 19~28°C. (Not set during FAN operation) The setting can be rendered void by touching the <b>▲</b> button when at the upper limit and the <b>▼</b> button when at the lower limit. [--] will be displayed when the setting will be rendered void.
Operating mode setting	Touch any of the buttons between <b>COOL</b> and <b>AUTO</b> to switch between operating modes for the selected group. The selection can be canceled by touching the selected button once more, and the setting will be rendered void.
Prohibition Setting For Remote Controller	Touch the <b>PROHIBIT</b> or <b>PERMIT</b> buttons to prohibit or permit specific function of the remote controllers for the selected groups. The selection can be canceled by touching the selected button once more, and the setting will be rendered void. The items that can be prohibited when <b>PROHIBIT</b> has been selected (ON/OFF, Operating mode, Temperature, and Filter sign reset) are set on The Prohibited Item Selected Screen (→ p.44).
Filter sign reset	The filter sign for all selected groups will be reset when <b>Reset</b> is touched.



- NOTE:** ● Fields that cannot be operated will be displayed faintly and it will not be possible to select the corresponding button.
- ① Air direction settings and fan speed settings for an entire floor or the whole building are not possible.
  - ② If touch the  button on the ON/OFF setting, it will not be possible to set the [Temperature setting], [Operating mode setting] and [Filter sign reset].
  - ③ If touch the  button on the operating mode setting, it will not be possible to set the [Temperature setting].

## (3-2) Entire floor and whole building operations (LOSSNAY groups)

- Touch the **OK** button after the operation settings have been made to switch across to the operations status for the selected groups.
- If you desire to cancel the settings (Contents of Settings), touch the **Cancel** button.
- If the operation status of items have not been selected, the previously set conditions remain as they are.

Example: When neither **ON** nor **OFF** have been selected:

- Operating LOSSNAY units will continue to operate.
- Halted LOSSNAY units will remain halted.

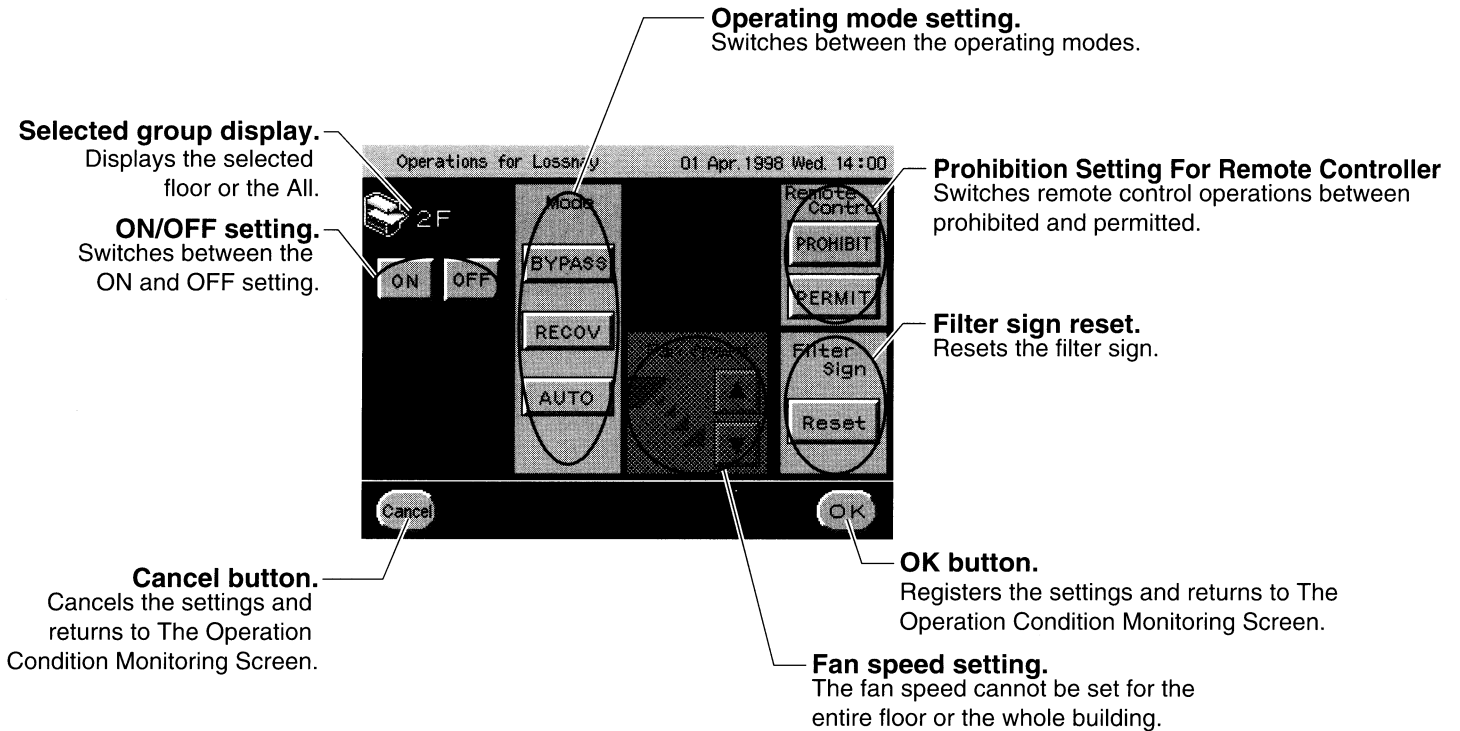

Function	Operations
ON/OFF setting	Touch either the <b>ON</b> or <b>OFF</b> buttons to switch the groups ON and OFF. The selection can be canceled by touching the selected button once more, and the setting will be rendered void.
Operating mode setting	Touch any of the <b>BYPASS</b> , <b>RECOV</b> and <b>AUTO</b> buttons to switch between operating modes for the selected group. The selection can be canceled by touching the selected button once more, and the setting will be rendered void.
Prohibition Setting For Remote Controller	Touch the <b>PROHIBIT</b> or <b>PERMIT</b> buttons to prohibit or permit specific function of the remote controllers for the selected groups. The selection can be canceled by touching the selected button once more, and the setting will be rendered void. The items that can be prohibited when <b>PROHIBIT</b> has been selected (ON/OFF, Operating mode, Temperature, and Filter sign reset) are set on The Prohibited Item Selected Screen (→ p.44).
Filter sign reset	The filter sign for all selected groups will be reset when <b>Reset</b> is touched.

**NOTE:**

- Fields that cannot be operated will be displayed darkly and it will not be possible to select the corresponding button.
  - ① Fan speed settings for an entire floor or the whole bldg. are not possible.
  - ② If touch the **OFF** button on the ON/OFF setting, it will not be possible to set the [Operating mode setting] and [Filter sign reset].

### (3-3) Entire floor and whole building operations (Air-conditioning and LOSSNAY groups)

- Touch the **OK** button after the operation settings have been made to switch across to the operations status for the selected group.
- If you desire to cancel the settings (Contents of Settings), touch the **Cancel** button.
- If the operation status of items have not been selected, the previously set conditions remain as they are.

Example: When neither **ON** nor **OFF** have been selected:

- Operating air-conditioners and LOSSNAY units will continue to operate.
- Halted air-conditioners and LOSSNAY units will remain halted.

#### Selected group display.

Displays the selected floor or the whole bldg.

#### ON/OFF setting.

Switches between the ON and OFF setting.

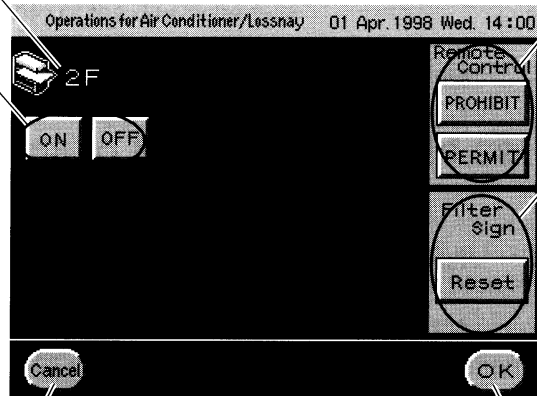

#### Prohibition Setting For Remote Controller

Switches remote control operations between prohibited and permitted.

#### Filter sign reset.

Resets the filter sign.

#### Cancel button.

Cancels the settings and returns to The Operation Condition Monitoring Screen.

#### OK button.

Registers the settings and returns to The Operation Condition Monitoring Screen.

Function	Operations
ON/OFF setting	Touch either the <b>ON</b> or <b>OFF</b> buttons to switch the groups ON and OFF. The selection can be canceled by touching the selected button once more, and the setting will be rendered void.
Prohibition Setting For Remote Controller	Touch the <b>PROHIBIT</b> or <b>PERMIT</b> buttons to prohibit or permit specific function of the remote controllers for the selected groups. The selection can be canceled by touching the selected button once more, and the setting will be rendered void. The items that can be prohibited when <b>PROHIBIT</b> has been selected (ON/OFF, Operating mode, Temperature, and Filter sign reset) are set on The Prohibited Item Selected Screen (→ p.44).
Filter sign reset	The filter sign for all selected groups will be reset when <b>Reset</b> is touched.

**NOTE:** ● Items which cannot be operated appear dark in the display and their operating buttons do not respond to touch.

- ① Touch **OFF** at the ON/OFF operation setting.  
The [Filter sign reset] item cannot be operated.

## 4-3. Schedule operations

- It is possible to set a schedule for each group with this system as explained below.
  - ① Weekly schedule (→ p.24)
    - It is possible to set schedule patterns for a period of one week.
    - ON/OFF, operating mode and other operations are executed automatically on the days and at times specified in the schedule (a maximum of six different operations can be specified for each day.)
  - ② Exception-day schedule (→ p.32)
    - It is possible to set up to fifty different exception-day schedule patterns for a year.
    - ON/OFF, operating mode and other operations are executed automatically on the days and at times specified in the schedule (a maximum of six different operations can be specified for each day.)
- When both weekly schedules and exception-day schedules have been set for the same day, the exception-day schedule will take priority.

## 4-3-1. Setting up weekly schedules

- ON/OFF, operating mode and other operations are executed automatically on the days and at times specified in the schedule (a maximum of six different operations can be specified for each day.)
- It is possible to allocate twelve different types of day-schedule (one-day schedule patterns), and set a weekly schedule pattern for each group.
- The weekly schedule is set up in accordance with the following procedures.
  - (1) Setting up one-day schedule patterns → p.24
  - (2) Setting up weekly schedules → p.30

### (1) Setting up one-day schedule patterns (day-schedules)

- Day-schedules are set up in accordance with the following procedures.
  - (1-1) Moving across to The Day-schedule Set-up Screen → p.24
  - (1-2) Setting up the name of the day-schedule → p.25
  - (1-3) Setting up the operation time of the day-schedule → p.26
  - (1-4) Setting up the operational contents of the day-schedule → p.27

#### (1-1) Moving across to the day-schedule set-up screen

The Operation Condition Monitoring Screen.

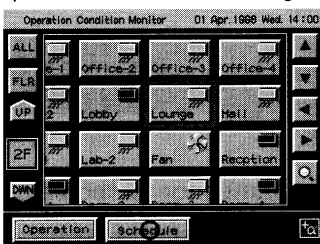

- ① Touch the group that requires schedule operation on The Operation Condition Monitoring Screen.

Touch **ALL** if the whole building is required or **FLR** if an entire floor is required, and then select the type (air-conditioner or LOSSNAY.)

- ② Touch the **Schedule** button to move across to The Schedule Set-up Screen.

The Schedule Setting Screen.

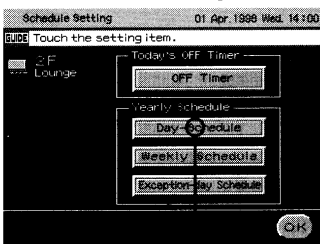

- ③ Touch the **Day-Schedule** button to move across to The Day-schedule Set-up Screen.

The Day-schedule Setting Screen.

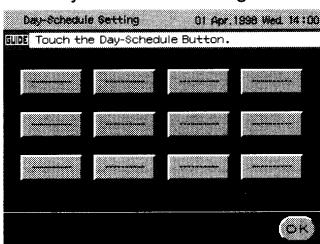

**NOTE:**

- A total of twelve daily schedules can be set up overall.
- The backlight will be automatically extinguished and the screen will return to the operation condition monitoring screen (→ p.4) when no operation is made on the schedule setting screen for a period exceeding ten minutes. (During a malfunction, the backlight does not go off.)

## (1-2) Setting up the name of the day-schedule

- Select [Weekday 1 to 9], [Holiday 1 to 9] or [Exception-day 1 to 9] as the name of the day-schedule pattern.

The Day-schedule Setting Screen.

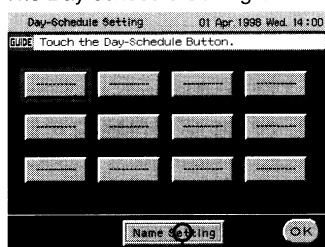

The Name Setting Screen.

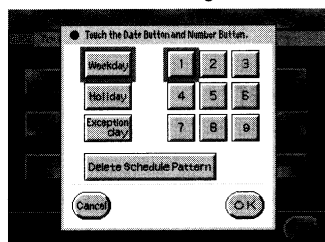

The Day-schedule Setting Screen.

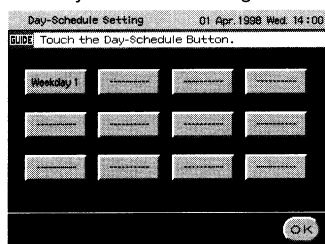

- ① Touch the button for the day-schedule that requires set-up or modification.
- ② Touch the button to move across to The Name Setting Screen.
- ③ Touch either , or .
- ④ Touch any number between and to set the number. It is not possible to touch numbers already set up.
- ⑤ Touch the button after selecting the name of the day-schedule to move across to The Day-schedule Screen. (When returning to The Day-schedule Screen, the name set up in items ③ and ④ will be displayed in the button selected in item ①.)  
If the name selected is to be deleted, touch the button and then touch the button.
- ⑥ Repeat items ① to ⑤ until the names for all required schedule patterns have been set up.

**NOTE:** ● Touch the button after selecting on the name setting screen to delete the contents of the schedule (p.26 to 29) set against that name. The day and exception-day schedule entered against the name with the weekly schedule (p.30) and exception-day schedule (p.32) will also be deleted.

## (1-3) Setting up the operation time of the day-schedule

- Set the time that the schedule is to be operated.
- Schedules can be operated a maximum of six timers per day.

The Day-schedule Setting Screen.

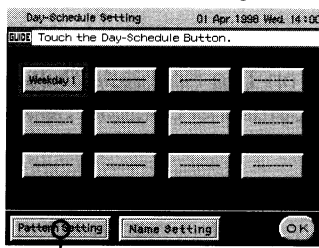

- ① Touch the day-schedule button ( **Weekday 1** , for example) for which the schedule contents are to be set.
- ② Touch the **Pattern Setting** button to move across to The Schedule Pattern Setting Screen.

The Schedule Pattern Setting Screen.

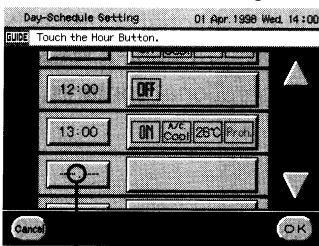

- ③ Touch the time button ( **12:00** ) that is to be set up or amended to move across to The Time Setting Screen.

The Time Setting Screen.

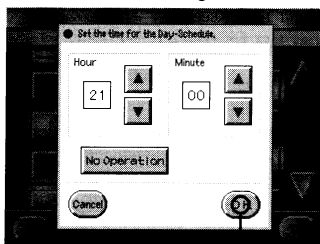

- ④ Use the **▲** and **▼** buttons to set the time of schedule execution.
- ⑤ Touch the **OK** button once the time has been set to return to The Schedule Pattern Setting Screen.  
If the schedule pattern is to be deleted, touch the **No Operation** button and then touch the **OK** button.

The Schedule Pattern Setting Screen.

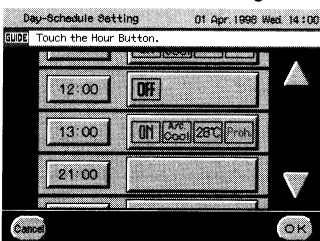

**NOTE:** ● Touch the **OK** button after selecting **No Operation** on The Time Setting Screen to delete the previously set time and the contents of the schedule (p.27).

# (1-4) Setting up the operational contents of the day-schedule

- Set up the operational contents of the schedule.
- Schedules can be set up to be operated a maximum of six timers per day.

The Schedule Pattern Setting Screen.

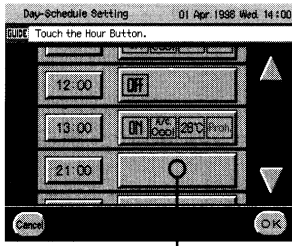

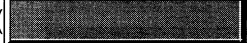
- ① Touch the pattern button (  ) for which the contents are to be set or modified on The Schedule Pattern Setting Screen to move across to The Operational Contents Setting Screen.

The Operational Contents Setting Screen.

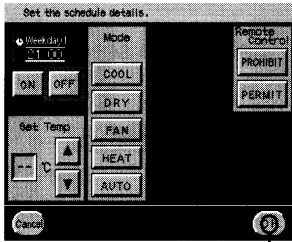

- ② Touch the  button when the operational contents have been set up to return to The Schedule Pattern Setting Screen. Refer to p28 for details on setting up the operational contents.

The Schedule Pattern Setting Screen.

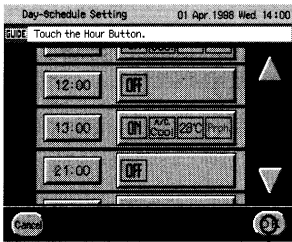

- ③ Touch the  button after all schedule operation times and operational contents have been set up to return to The Day-schedule Setting Screen.

The Day-schedule Setting Screen.

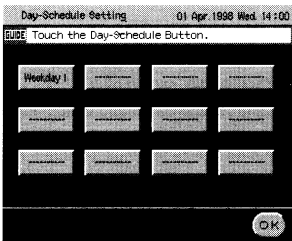

- ④ Set the times and operational contents for all required schedules.



## ● Setting up the operational contents

- Touch the **OK** button after the operational content settings have been made to register the operational contents for the schedule.
- If the operation status of items have not been selected, the previously set conditions remain as they are.

Example: When neither **ON** nor **OFF** have been selected:

- Operating air-conditioners and LOSSNAY units will continue to operate.
- Halted air-conditioners and LOSSNAY units will remain halted.

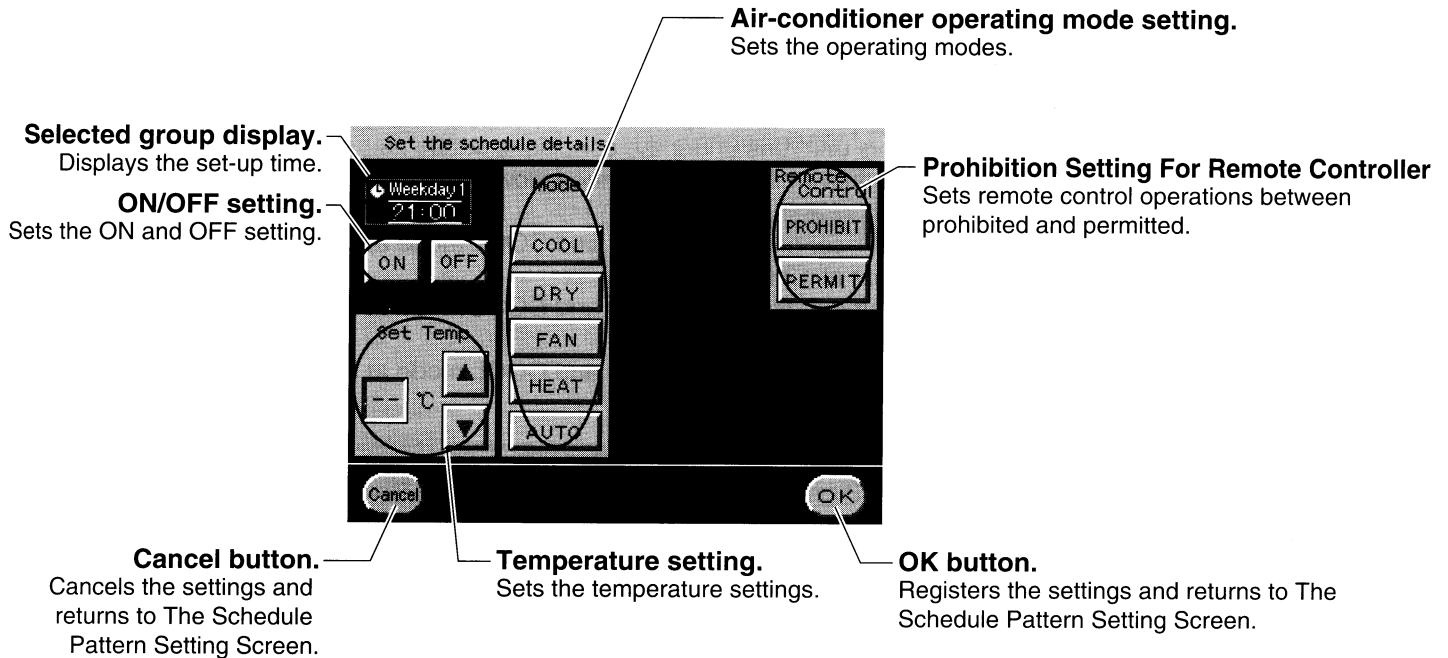

Function	Operations
ON/OFF setting	Touch either the <b>ON</b> or <b>OFF</b> buttons to switch the groups ON and OFF. The selection can be canceled by touching the selected button once more, and the setting will be rendered void.
Temperature setting	<p>Touch the <b>▲</b> and <b>▼</b> buttons to set the temperature.</p> <p>COOL/DRY operations : 19 to 30 °C            HEAT operations : 17 to 28 °C            AUTO operations : 19 to 28 °C            When operating mode not set : 19 to 28 °C            (Not set during FAN operation)</p> <p>The setting can be rendered void by touching the <b>▲</b> button when at the upper limit and the <b>▼</b> button when at the lower limit.            [--] will be displayed when the setting will be rendered void.</p>
Air-conditioner operating mode setting	Touch any of the buttons between <b>COOL</b> and <b>AUTO</b> to set the operation mode for the air-conditioning group on the schedule. The selection can be canceled by touching the selected button once more, and the setting will be rendered void.
Prohibition Setting For Remote Controller	Touch the <b>PROHIBIT</b> or <b>PERMIT</b> buttons to prohibit or permit specific function of the remote controllers for the selected groups. The selection can be canceled by touching the selected button once more, and the setting will be rendered void. The items that can be prohibited when <b>PROHIBIT</b> has been selected (ON/OFF, Operating mode, Temperature, and Filter sign reset) are set on The Prohibited Item Selected Screen (→ p.44).

- NOTE:**
- By setting the day-schedule (one day's operation pattern) and assigning it to each group with the weekly schedule (→ p.30) or exception-day schedule (→ p.32), it is possible to execute the operational pattern automatically up to a maximum of six times.
  - It is possible to set only the items (temperature setting, operating mode, etc.) apart from the ON/OFF item with the schedule. When operations apart from ON/OFF are executed by the schedule, the schedule operations will be reflected on the units that are up and running, and will be operated on the units that are not up and running the next time they are activated with the remote controller.  
Example: When only operating COOL mode is executing with the schedule.
    - For the units that are running, the units will be COOL mode.
    - For the units that are not running, the units will be COOL mode at the next time that operations are started.
  - If the running conditions have been changed using the remote control since the time when the schedule was executed, this unit runs under the conditions set by the remote control.
  - Create the necessary schedule while referring to the following example.

Example #1:

- ① Activate the air-conditioner at 30 °C and COOL mode at 09:00.
- ② Halt operations at 12:00
- ③ Activate the air-conditioner at 28 °C and COOL mode at 13:00.
- ④ Halt operations at 17:00
- ⑤ Activate the air-conditioner at 30 °C and COOL mode at 17:30.
- ⑥ Halt operations at 21:00

09:00	ON	Cool	30°C
12:00	OFF		
13:00	ON	Cool	28°C
17:00	OFF		
17:30	ON	Cool	30°C
21:00	OFF		

Example #2:

- ① Activate the air-conditioner at 28 °C and COOL mode at 09:00 and prohibit specific function of the remote controllers at the same time
- ② Halt operations at 17:00 and permit specific function of the remote controllers

09:00	ON	A/C Cool	28°C	Prohi.
17:00	OFF			Permit

Example #3:

- ① Activate the air-conditioner at 20 °C and HEAT mode when the remote control is turned ON  
(If 00:00 is set as the time stipulation, the schedule pattern will be activated when the remote controllers are operated any time after 00:00.)

00:00		A/C Heat	20°C
-------	--	-------------	------

## (2) Setting up weekly schedules

- Weekly schedules are set up in accordance with the following procedures.
  - (2-1) Moving across to the weekly schedule set-up screen → p.30
  - (2-2) Setting up weekly schedules → p.31

### (2-1) Moving across to the weekly schedule set-up screen

The Operation Condition Monitoring Screen.

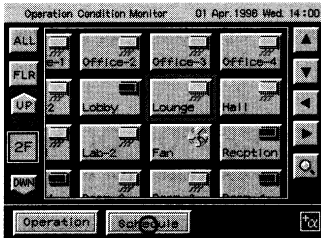

- ① Select the group that requires schedule operation on the operation condition monitoring screen. Touch **ALL** if the whole building is required or **FLR** if an entire floor is required, and then select the type (air-conditioner or LOSSNAY.)

- ② Touch the **Schedule** button to move across to The Schedule Setting Screen.

The Schedule Setting Screen.

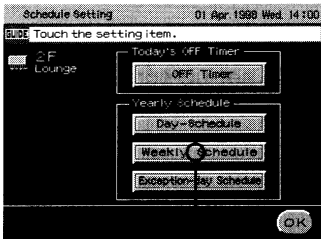

- ③ Touch the **Weekly Schedule** button to move across to The Weekly Schedule Setting Screen.

The Weekly Schedule Setting Screen.

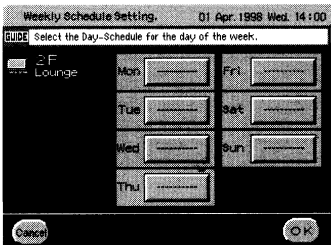

- NOTE:**
- A weekly schedule can be set up for each group.
  - When both weekly schedules and exception-day schedules have been set for the same day, the exception-day schedule will take priority.
  - The weekly schedule will be executed immediately after being set up.
  - The backlight will be automatically extinguished and the screen will return to the operation condition monitoring screen (→ p.4) when no operation is made on any of the weekly schedule setting screens for a period exceeding ten minutes. (During a malfunction, the backlight does not go off.)

## (2-2) Setting up weekly schedules

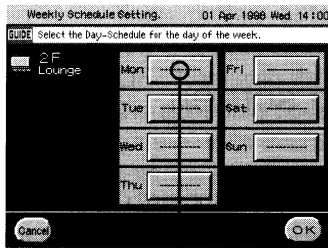

The Weekly Schedule Setting Screen.

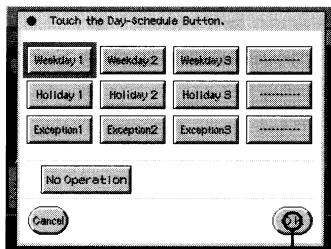

- ① Touch the  button for the day-schedule that requires set-up to move across to The Day-schedule Selection Screen.

The Day-schedule Selection Screen.

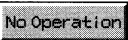

- ② Select the day-schedule that is to be executed for the selected day from the available list.
- ③ Touch the  button after selecting the day-schedule to move across to The Weekly Schedule Screen. If the day-schedule assigned to a particular day is to be deleted, touch the  button and then touch the  button.

The Weekly Schedule Setting Screen.

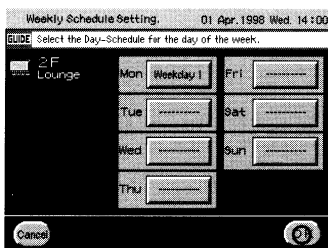

- ④ Touch the  button when day-schedules have been assigned to all days to return to the schedule set-up screen.

The Schedule Setting Screen.

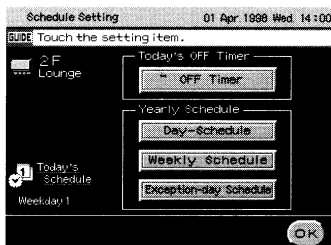

## 4-3-2. Setting up exception-day schedules

- ON/OFF, operating mode and other operations are executed automatically on the days and at times specified in the exception-day schedule (a maximum of 6 different operations can be specified for each day.)
- It is possible to allocate 12 different types of day-schedule (one-day schedule patterns) for each date, and set a yearly schedule pattern for each group (a maximum of 50 days for each group.)
- It is necessary to set up the day-schedules (one-day schedule patterns) prior to setting up the exception-day schedule (refer to page 24.)
- The exception-day schedule is set up in accordance with the following procedures.
  - (1) Moving across to the exception-day schedule set-up screen → p.32
  - (2) Setting up exception-day schedule patterns → p.33
  - (3) Selecting day-schedules for allocating to exception-days → p.34

### (1) Moving across to the exception-day schedule set-up screen

The Operation Condition Monitoring Screen.

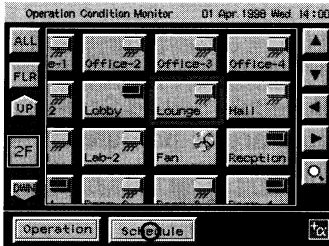

- ① Touch the group that requires setting up on The Operation Condition Monitoring Screen. Touch each group button if the set-up is to be performed by group. Touch **ALL** if the whole building is required or **FLR** if an entire floor is required, and then select the type (air-conditioner or LOSSNAY.)

- ② Touch the **Schedule** button to move across to The Schedule Setting Screen.

The Schedule Setting Screen.

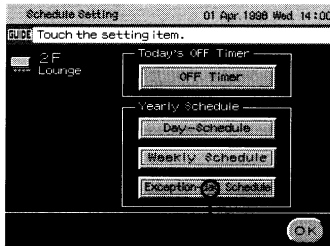

- ③ Touch the **Exception-day Schedule** button to move across to The Exception-day Schedule Setting Screen.

The Exception-day Schedule Setting Screen.

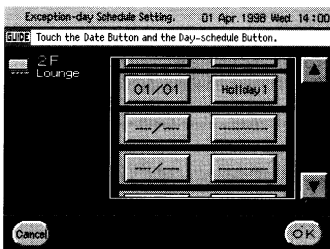

- NOTE:**
- Exception-day schedules can be set up for a maximum of 50 days for each group.
  - When both weekly schedules and exception-day schedules have been set for the same day, the exception-day schedule will take priority.
  - The exception-day schedule will be executed immediately after being set up.
  - The backlight will be automatically extinguished and the screen will return to the operation condition monitoring screen (→ p.4) when no operation is made on any of the exception-day schedule setting screens for a period exceeding ten minutes. (During a malfunction, the backlight does not go off.)

## (2) Date setting

The Exception-day Schedule Setting Screen.

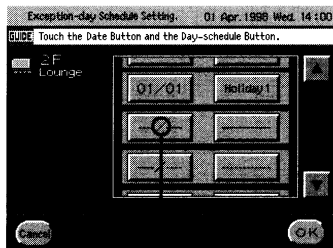

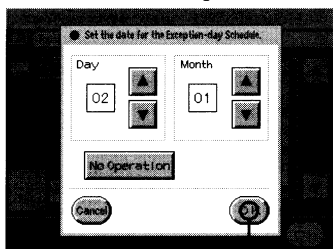

The Date Setting Screen.



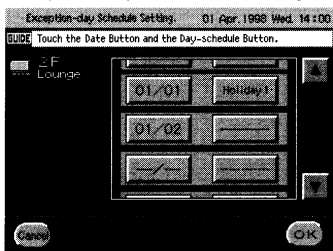



The Exception-day Schedule Setting Screen.



① Touch the date button (  ) for the date to be set up to move across to The Date Setting Screen.

② Touch the  and  buttons to set the date on which the schedule is to be executed.

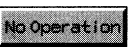
③ Touch the  button after the date has been entered to move across to The Exception-day Schedule Setting Screen. If the contents of the schedule are to be deleted, touch the  button and then touch the  button.

**NOTE:** ● After selecting  in the date setting screen and touching , the date and schedule contents (p.34) are erased.

### (3) Day-schedule selection

The Exception-day Schedule Setting Screen.

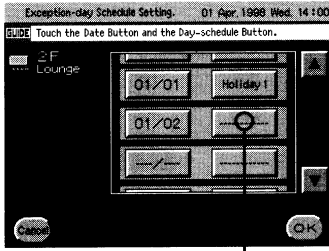

- ① Touch the day-schedule button ( ) for the date to be set up to move across to The Day-schedule Selection Screen.

The Day-schedule Selections Screen.

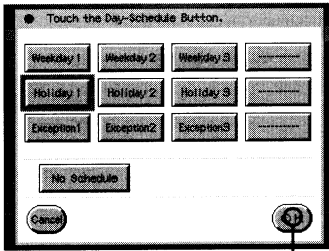

- ② Select the day-schedule that is to be executed for the selected exception day from the available list.
- ③ Touch the **OK** button after selecting the day-schedule to move across to The Exception-day Schedule Setting Screen. If the day-schedule assigned to the special day is to be deleted, touch the **No Schedule** button and then touch the **OK** button.

The Exception-day Schedule Setting Screen.

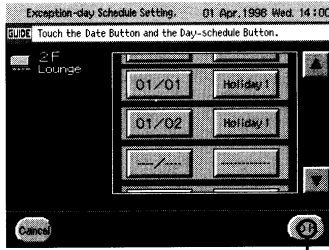

- ④ Touch the **OK** button when day-schedules have been assigned to all exception-days to return to The Schedule Setting Screen.

The Schedule Setting Screen.

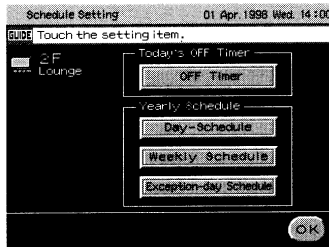

**NOTE:**

- When schedule operations are not required for certain days, such as national holidays, even when they are included in the weekly schedule, select **No Schedule** on the day schedule selection screen after setting the date on the exception-day setting screen.
- Select **No operation** on the date setting screen (p.33) to delete an assigned day schedule.

### 4-3-3. Setting up the OFF timer

- Units will automatically be switched off at a specified date and time when the OFF timer is set.
- The OFF timer is set up by observing the following procedure.
  - (1) Moving across to the OFF timer set-up screen → p.35
  - (2) Setting the OFF timer → p.36

#### (1) Moving across to the OFF timer set-up screen

The Operation Condition Monitoring Screen.

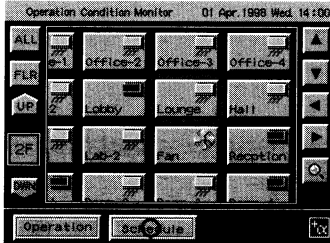

- ① Touch the group that requires setting up on The Operation Condition Monitoring Screen.  
Touch each group button if the set-up is to be performed by group.  
Touch **ALL** if the whole building is required or **FLR** if an entire floor is required, and then select the type (air-conditioner or LOSSNAY.)
- ② Touch the **Schedule** button to move across to The Schedule Setting Screen.

The Schedule Setting Screen.

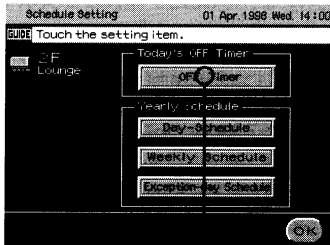

- ③ Touch the **OFF Timer** button to move across to The OFF Timer Setting Screen.

The OFF Timer Setting Screen.

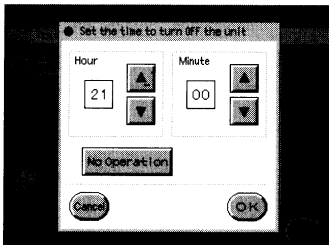



- NOTE:**
- The off timer can be set for each group.
  - Operations will be performed in accordance with the weekly schedule and exception-day schedule set up for the relevant day even for units that have the off timer set up. (Note that although the unit for which an off timer has been set will stop temporarily when the relevant time arrives, operations will then be performed in accordance with the schedule if a schedule has been set up.)
  - In addition to setting an off timer for halted units that operate temporarily and are then halted again two hours later, also operate the unit from the operation screen for the operation contents (→ p.7). (Operations may be performed either with the off timer setting or with unit operations.)
  - The backlight will be automatically extinguished and the screen will return to the operation condition monitoring screen (→ p.4) when no operation is made on any of the off timer setting screens for a period exceeding ten minutes. (During a malfunction, the backlight does not go off.)



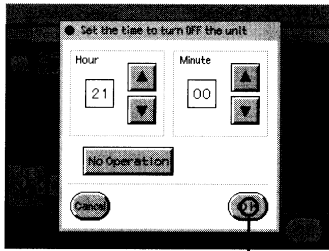

## (2) Time setting

The OFF Timer Setting Screen.

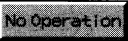

① Touch the  and  buttons to set the time that the unit is to be switched off.

② Touch the  button after the time has been entered to return to The Schedule Setting Screen.

If the contents of the OFF Timer are to be deleted, touch the  button and then touch the  button.

The Schedule Setting Screen.

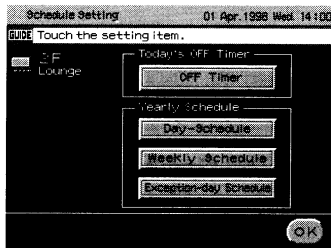

## 5. Malfunction monitor

- Displays the Group name for the unit that the malfunction has occurred, the unit address and the relevant error code.

### (1) Moving across to the malfunction monitoring screen

The Operation Condition Monitoring Screen.

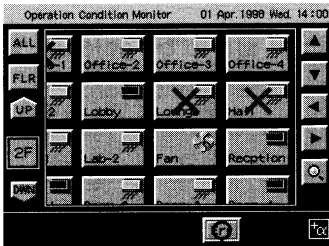

- ① Touch the **Err** button on The Operation Condition Monitoring Screen to move across to The Malfunction Monitor Screen.

The Malfunction Monitor Screen.

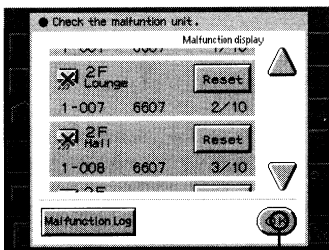

- ② Touch the **OK** button to return to The Operation Condition Monitoring Screen.

The Operation Condition Monitoring Screen.

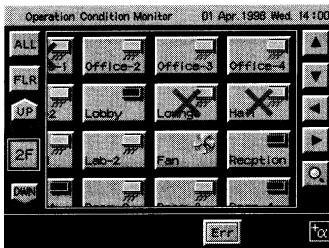

**NOTE:**

- The **Err** button will be displayed when an abnormality has occurred in even one of all the units.
- An [X] mark lights up above the button for the group in which the malfunction has occurred.
- During a malfunction, even if there is no operation for 10 minutes or longer, the backlight does not go off.

## (2) Display and operation methods

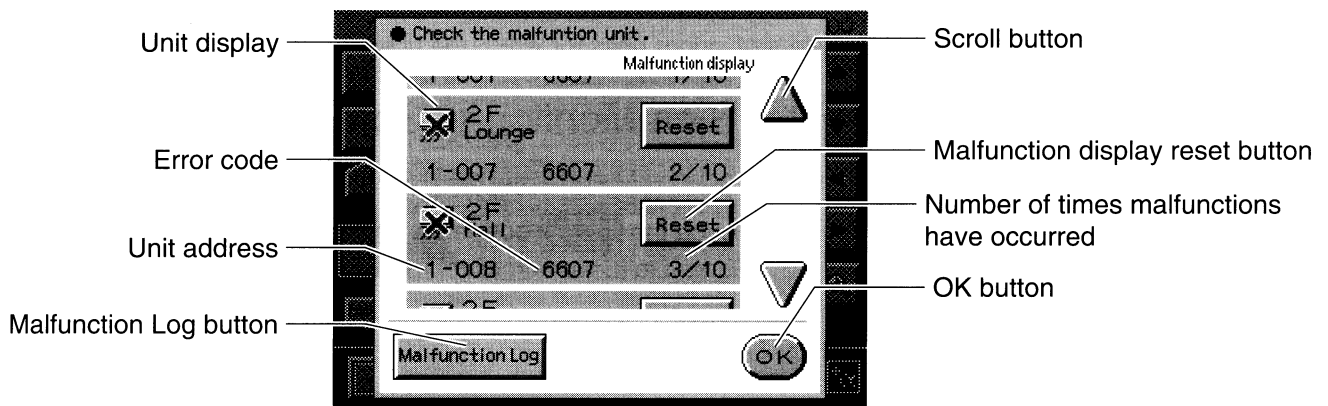

Function	Details
Unit display	Displays the Group name of the unit for which malfunction has occurred.
Scroll button	Scrolls the screen up and down.
Unit address	Displays the system number and the address of the unit in which the malfunction has occurred. ([System number] - [Unit address]) Example: The display will be as follows when malfunction occurs in a unit in system #1 with an address of 20: 1-020
Error code	The four-character number providing details on the malfunction.
Number of times malfunctions have occurred	Displays the total number of units in which malfunctions have occurred and the number of the current malfunction.
Malfunction display reset button	Switches off the unit and resets the malfunction display.
Malfunction Log button	Displays a history of abnormalities that have occurred up until that moment (maximum 200).
OK button	Returns to The Operation Condition Monitoring Screen.

**NOTE:**

- The error reset is a function to switch off the unit in which an malfunction occurred, and will not correct the error. Contact your dealer if errors are repeatedly triggered.
- It will take several seconds for the error reset signal to reach the unit occurred malfunction when the reset button has been touched this screen. Owing to this, there may be cases where the unit in question remains displayed as an error even after the error has been reset and the screen has been returned to the operation condition monitoring screen by touching the  button. The error display will automatically be deleted a few seconds after a normal reset procedure has been performed.

## 6. Operations when filter signs are triggered

- The time for cleaning the filters of each group will be notified to the operator with the filter sign.
- Reset the filter sign after cleaning the filters of indoor units for which the filter sign is being displayed.

### (1) Moving across to The Filter Sign Monitoring Screen

The Operation Condition Monitoring Screen.

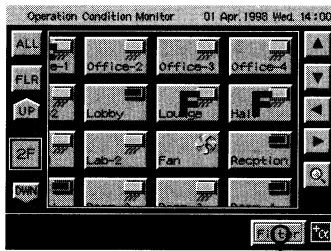

- ① Touch the **Filter** button on The Operation Condition Monitoring Screen to move across to The Filter Sign Monitoring Screen.

The Filter Sign Monitoring Screen.

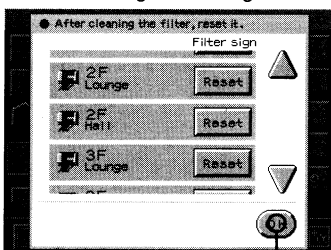

- ② Touch the **OK** button to return to The Operation Condition Monitoring Screen.

The Operation Condition Monitoring Screen.

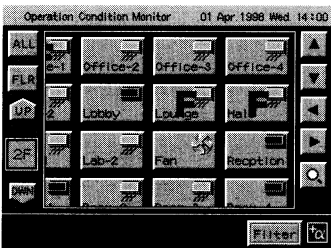

- NOTE:**
- The **Filter** button will be displayed even if the filter sign is triggered for only one unit from all units available.
  - An [F] mark lights up above the button of the group for which a filter sign has been triggered.

## (2) Display and operation methods

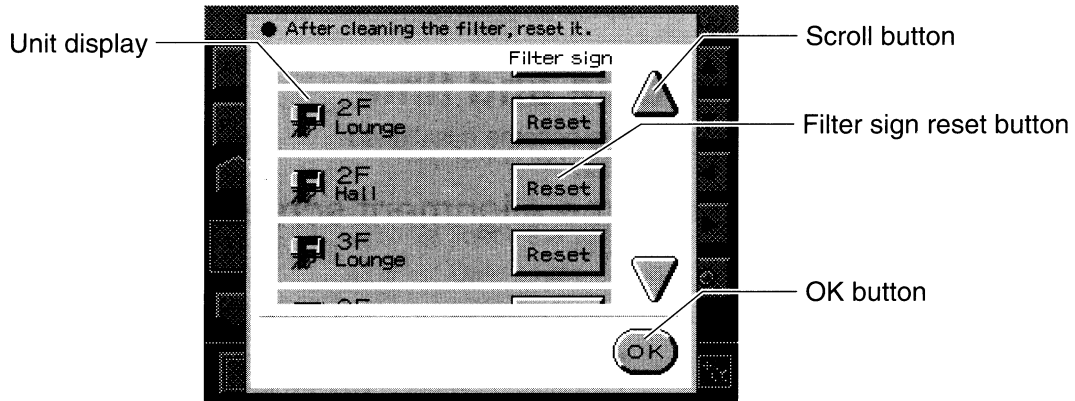

Function	Details
Unit display	Displays the Group name of the unit for which a filter sign has been triggered.
Scroll button	Scrolls the screen up and down.
Filter sign reset button	Resets the filter sign.
OK button	Returns to The Operation Condition Monitoring Screen.

**NOTE:** ● A filter sign is triggered in accordance with the amount of time the relevant unit has been in operation. Owing to this, the subsequent filter sign will not be triggered if it is reset even if the filter is soiled. **Ensure that the filter is cleaned when the filter sign is reset.**

# 7. Modifying all kinds of setting and monitoring the previous records

## 7-1. Setting the current date and time

- Set the correct date with this screen when it has become misaligned.

### (1) Moving across to the date/time alignment screen

The Operation Condition Monitoring Screen.

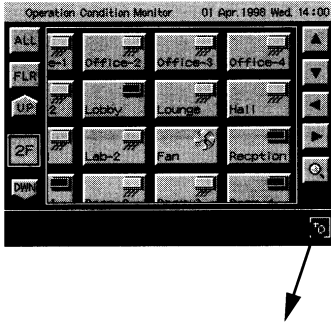

- ① Touch the  button at the bottom right-hand corner of The Operation Condition Monitoring Screen to move across to The All Kinds Of Setting / Previous Record Screen.

The All Kinds Of Setting / Previous Record Screen.

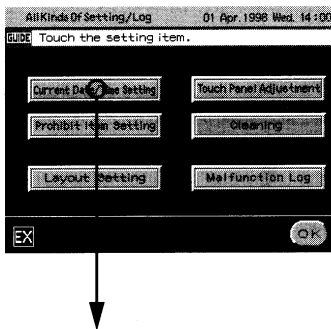

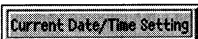
- ② Touch the  button to move across to The Date Alignment Screen.

The Date Alignment Screen.

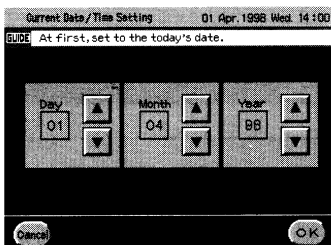





**NOTE:** ● The backlight will be automatically extinguished and the screen will return to the operation condition monitoring screen (→ p.4) when no operation is made on any of The All Kinds Of Setting / Previous Record Screens for a period exceeding ten minutes. (During a malfunction, the backlight does not go off.)

## (2) Setting the current date

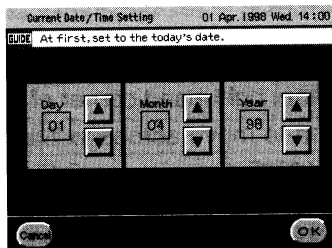
- This screen is displayed when the  button on The All Kinds Of Setting / Previous Record Screen is touched.

The Current Date / Time Setting (Date) Screen







- ① Touch the  and  icons to set the current date.
- ② Touch the  button to register the date and move to The Current Date / Time Setting (Time) Screen.  
If you desire to cancel the current date setting, touch the  button.

## (3) Setting the current date

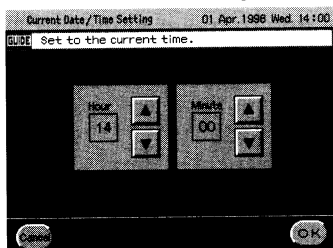
- This screen is displayed when the  button on The Current Date / Time Setting (Date) Screen is touched.

The Current Date / Time Setting (Time) Screen



- ① Touch the  and  icons to set the current time.
- ② Touch the  button to register the time and return to The All Kinds Of Setting / Previous Record Screen.  
If you desire to cancel the current time setting, touch the  button.

- NOTE:**
- The counting of time begins from the point when  is touched in the Current Date/Time Setting (Time) Screen.
  - The current time is saved for a period of approximately one week after the mains power has been cut off. (The power supply to the main system must be switched on continuously for 24 hours or more to save the data for a period of one week.)

## 7-2. Touch panel adjustments

- The position of the touch panel and the positions of the actual operation buttons are adjusted with the use of this screen.

### (1) Moving across to the touch panel adjustment screen.

The Operation Condition Monitoring Screen.

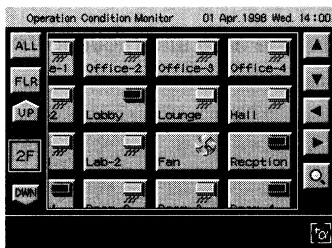

- ① Touch the **OK** button at the bottom right-hand corner of the operation condition monitoring screen to move across to The All Kinds Of Setting / Previous Record Screen.

The All Kinds Of Setting / Previous Record Screen.

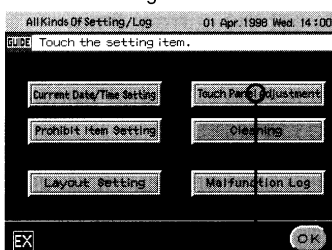

- ② Touch the **Touch Panel Adjustment** button to move across to The Touch Panel Adjustment Screen.

The Touch Panel Adjustment Screen.

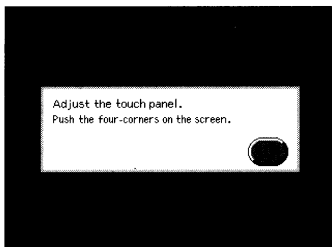

### (2) Touch panel adjustments

- The position of the touch panel can be adjusted by touching each of the screen's four corners.

The Touch Panel Adjustment Screen.

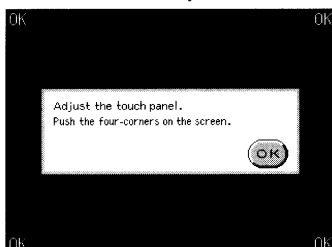

- ① Touch the four corners of the screen (the area marked [OK] on the left-hand diagram.) **OK** will be displayed wherever the screen is touched.
- ② Touch the **OK** button to return to the all kinds of setting/previous record screen.



## 7-3. Setting the operation prohibited item for remote controllers

- It is possible to prohibit ON/OFF, Temperature setting, Operating mode and Filter sign reset operations for remote controllers with The Operation Control Screen (p.7) for each group.
- All functions are set at [PROHIBIT] when shipped from the factory.  
The operations when each item is selected and remote control operations prohibited on The Operation Control Screen are as follows.

Selected item	Operations
ON/OFF Operation	Not able to switch unit ON or OFF with the remote controller.
Temperature Setting	Not able to switch the temperature settings with the remote controller. (Air-conditioners only).
Operation Mode	Not able to switch the operation modes with the remote controller. (Air-conditioners only)
Filter	Not able to reset the filter sign with the remote controller.

### (1) Moving across to the prohibited screen

The Operation Condition Monitoring Screen.

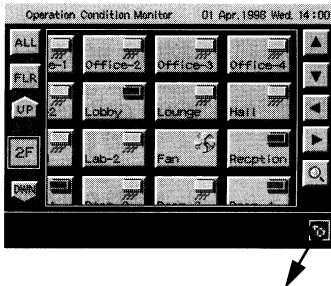

- ① Touch the **Prohibit Item Setting** button at the bottom right-hand corner of the operation condition monitoring screen to move across to The All Kinds Of Setting / Previous Record Screen.

The All Kinds Of Setting / Previous Record Screen.

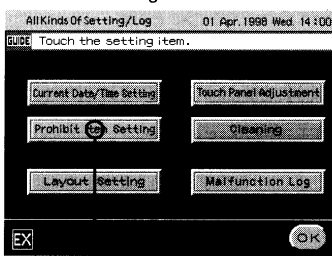

- ② Touch the **Prohibit Item Setting** button to move across to The Screen For Selecting The Required Units.

The Screen For Selecting The Required Units.

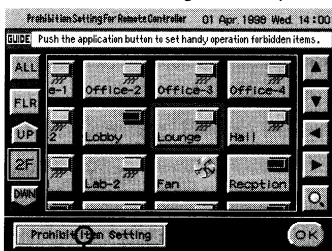

- ③ Select the group for which remote control operations are to be prohibited on The Screen For Selecting The Required Units. Touch the relevant group buttons if the setting is to be made by group. Select the unit type (air-conditioner or LOSSNAY) after touching the **ALL** button when batch operations for the whole building are required or **FLR** button when batch operations for an entire floor are required.

The Screen For Selecting The Items.

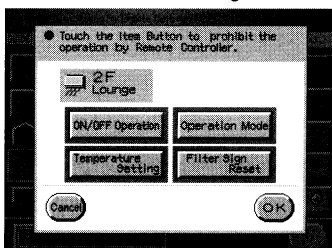

- ④ Touch the **Prohibit Item Setting** button to move across to The Screen For Selecting The Items that are to be prohibited.

## (2) Selecting the items to be prohibited

- Touch the item Button to prohibit the operation by remote controller.

The Screen For Selecting The Items.

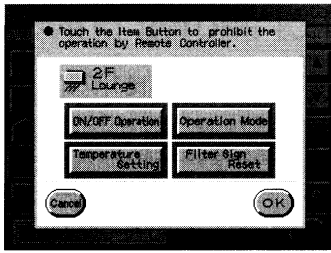

- ① Select all items for which operations with remote controllers are to be prohibited. The button will be framed to indicate it has been selected when touched.

To cancel the selection:

Touch the group button for the items selected to cancel the selection.

- ② Touch the  button to move across to The Screen For Selecting The Required Units.

**NOTE:** ● Remote control operations will not be prohibited simply by selecting the required items on this screen. Remote control operations are prohibited only after the  button has been selected on The Operations Setting Screen (refer to p.7) and the items set on this screen.

## 7-4. Layout modifications

- This screen is used to amend the position, size and names of the group buttons, marks and lines.
- It is possible to create an operation screen similar to the one shown below by setting up a layout.

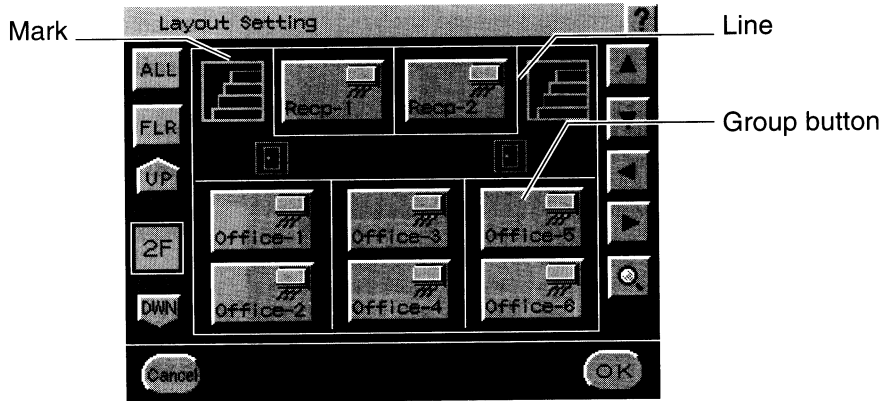



- Refer to the following pages for details on how to set up and layout with the layout setting screen.
  - Moving group buttons → p.48
  - Amending the size of group buttons → p.48
  - Amending the name of group buttons → p.48
  - Adding marks → p.49
  - Deleting marks → p.49
  - Moving marks → p.49
  - Amending the size of marks → p.49
  - Adding lines → p.50
  - Deleting lines → p.50
  - Moving lines → p.50
  - Amending the length of lines → p.50

**NOTE:** ● If you have added a new group button to the floor, the layout of the floor is initialized, so please set this screen once more.

### (1) Moving across to the layout setting screen

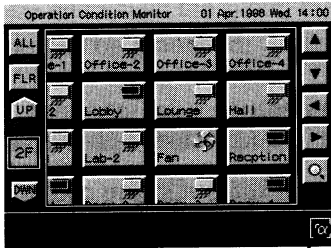
The Operation Condition Monitoring Screen.



- ① Touch the  button at the bottom right-hand corner of The Operation Condition Monitoring Screen to move across to The All Kinds Of Setting / Previous Record Screen.

The All Kinds Of Setting / Previous Record Screen.

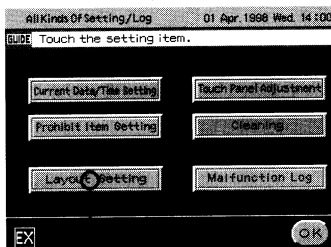

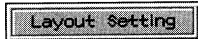
- ② Touch the  button to move across to The Layout Setting Screen.

The Layout Setting Screen.

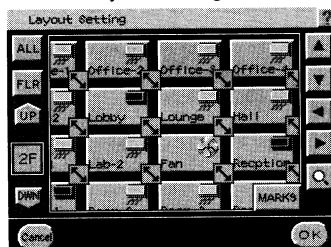

## (2) Names of The Layout Setting Screen fields

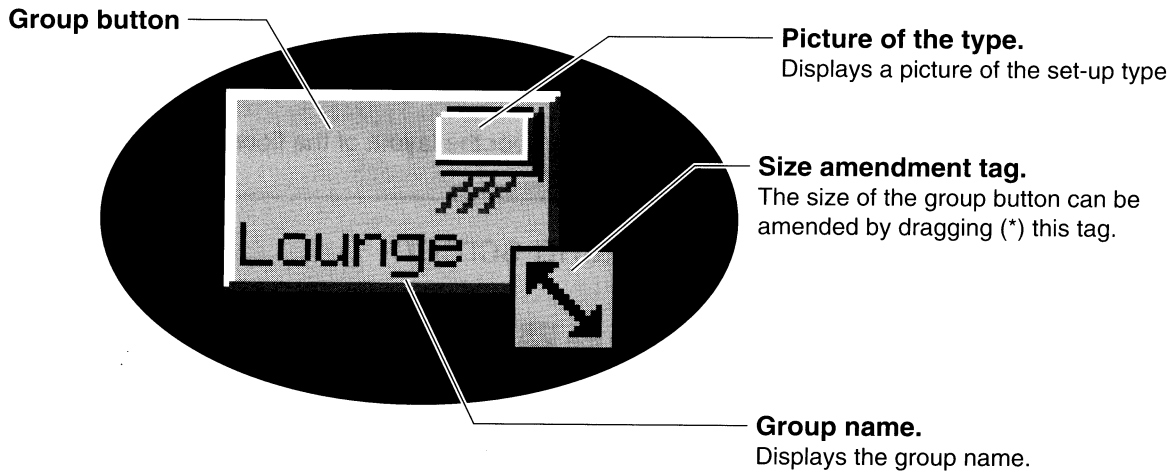
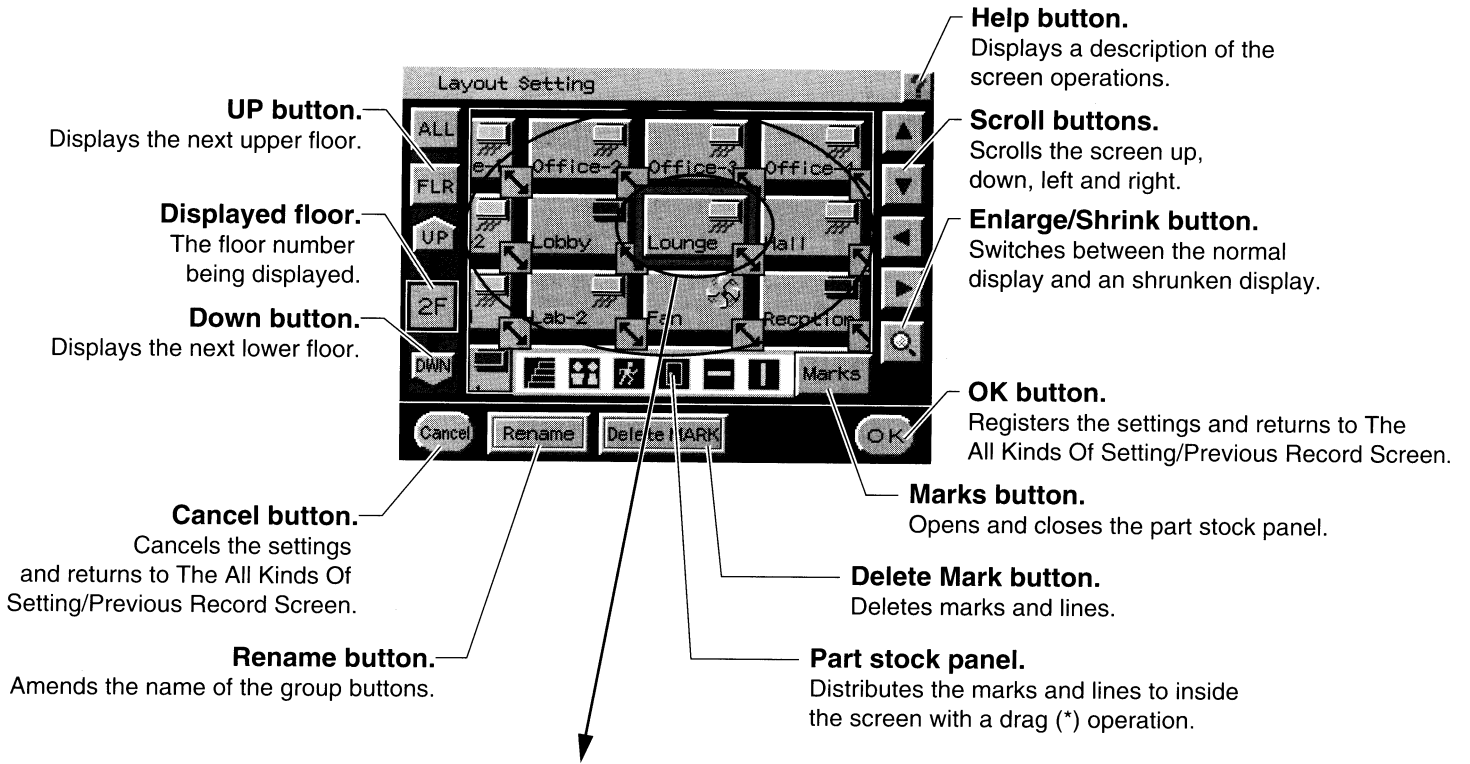

\*Drag: Moves the item within the screen by pressing on it and moving your finger without losing contact with the screen.

### (3) Moving group buttons

- Drag the group button that needs to be moved to the required location, and then release it. The group button will be positioned in the location where it was released.

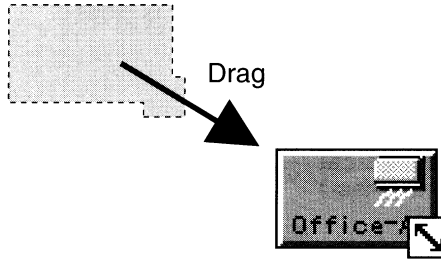

### (4) Amending the size of group buttons

- Drag the size amendment tag on the group button for which the size is to be amended until it is the required size, and then release it.

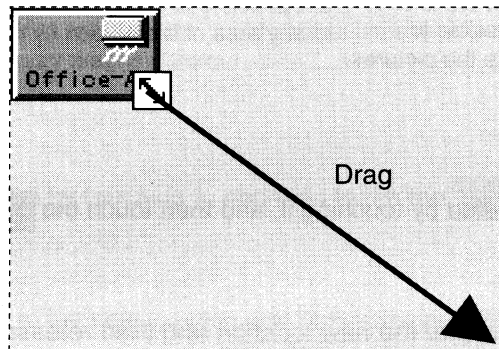

**NOTE:**

- The size of the group button cannot be made smaller than the standard size.
- The size of the type picture on the group button will be expanded in direct relation with the size of the group button, but the size of the group name characters will not change.

### (5) Amending group button names

- Touch and select the group button that needs to be amended and touch **Rename** to display a screen where the name can be amended.

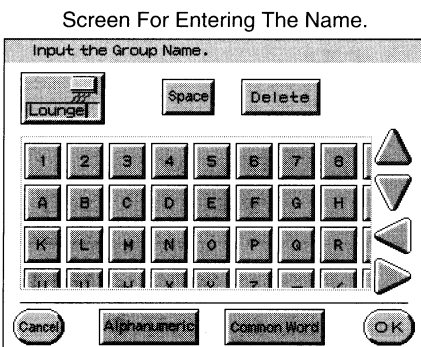

- ① Touch the **Delete** button to delete the current name.
- ② Enter the group name by touching the various character buttons.
- ③ Touch the **OK** button after the group name has been entered.

**NOTE:**

- Use an easy-to understand name for the group name.

**NOTE:**

- A maximum of eight characters may be used for the group name.

## (6) Adding marks

- Drag an additional mark (picture) from the part stock panel to the required location and then release it. The mark will then be planted in the place where it was released.
- Touch the MARKS button to open the part stock panel if it is closed.

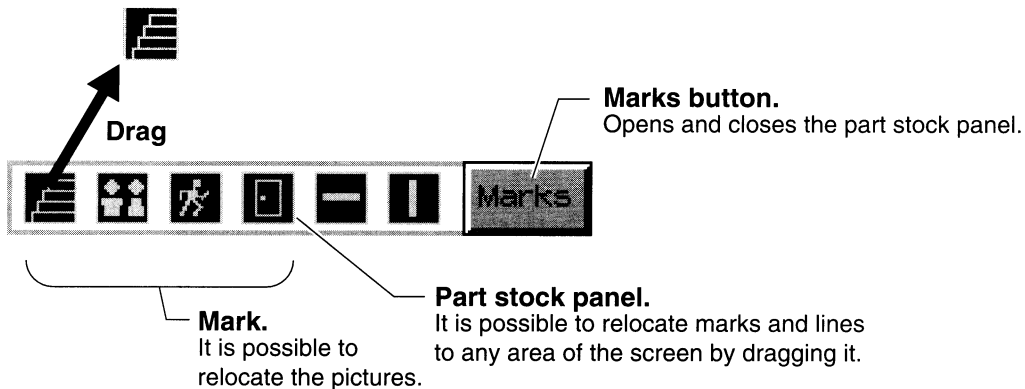

## (7) Deleting marks

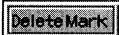
- Select the mark that is to be deleted by touching it, and then touch the  button.

## (8) Moving marks

- Drag the mark that is to be moved to the new location and then release it. The mark will be relocated in the location where it is released.

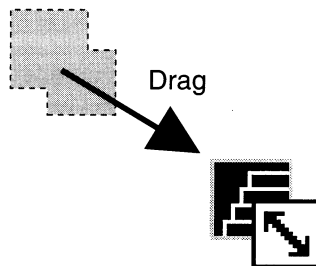

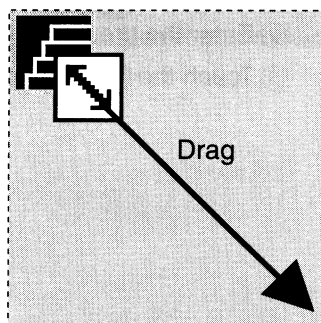

## (9) Amending the size of marks

- Drag the size amendment tag on the mark that needs to be enlarged until it reaches the required size, and then release it.



**NOTE:** ● The mark cannot be reduced to a size smaller than the standard size.

## (10) Adding lines

- Drag an additional horizontal line  or vertical line  from the part stock panel to the required location and then release it. The line will then be planted in the place where it was released.
- Touch the MARKS button to open the part stock panel.

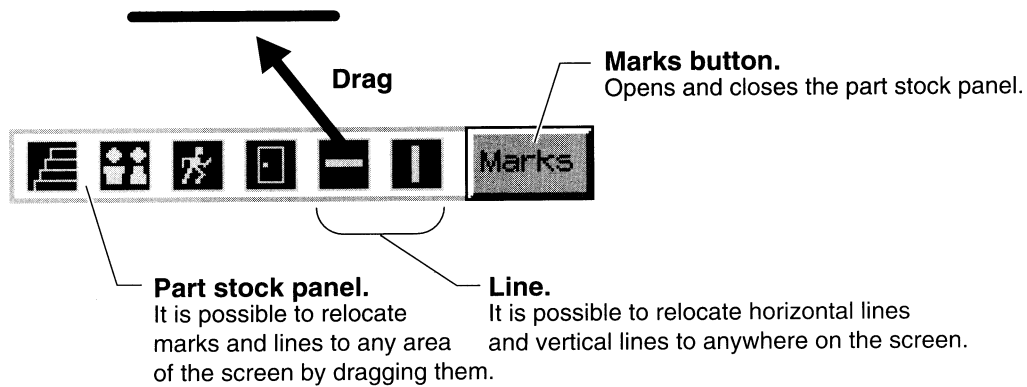

## (11) Deleting lines

- Select the line that is to be deleted by touching it, and then touch the  button.

## (12) Moving lines

- Drag the line that is to be moved to the new location and then release it. The line will be relocated in the location where it is released.

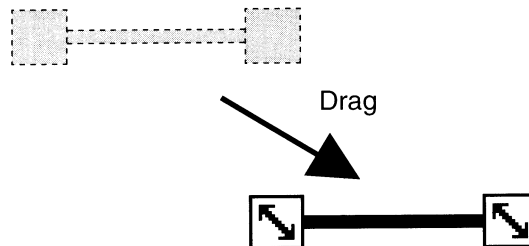

## (13) Amending the length of lines

- Drag the size amendment tag on the line that needs to be lengthened until it reaches the required length, and then release it.

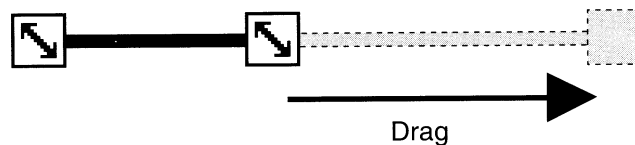

**NOTE:**

- The line cannot be reduced to a length smaller than the standard length.
- The length of the lines can only be lengthened horizontally for the horizontal lines, and vertically for the vertical lines.

## 7-5. Malfunction log display

- Displays a maximum of 200 past malfunctions (the oldest history data will be deleted in sequence when the number of malfunctions exceeds 200)

### (1) Moving across to the malfunction log screen

The Operation Condition Monitoring Screen.

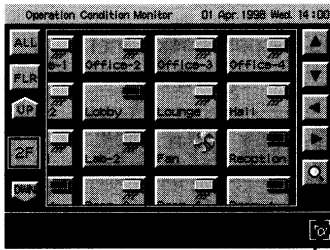

- ① Touch the  button at the bottom right-hand corner of The Operation Condition Monitoring Screen to move across to The All Kinds Of Setting / Previous Record Screen.

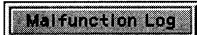
- ② Touch the  button to move across to The Malfunction Log Screen.

The All Kinds Of Setting / Previous Record Screen.

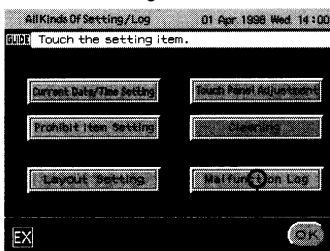

The Malfunction Log Screen.

Occurred Date/Time	Recovery Date/Time	Occurred Address	Error Code
18:20:00	18:20:00	1-001	5607
06-11-20 18:20:39	06-11-20 18:20:50	1-001	5607



## (2) Display and operation methods

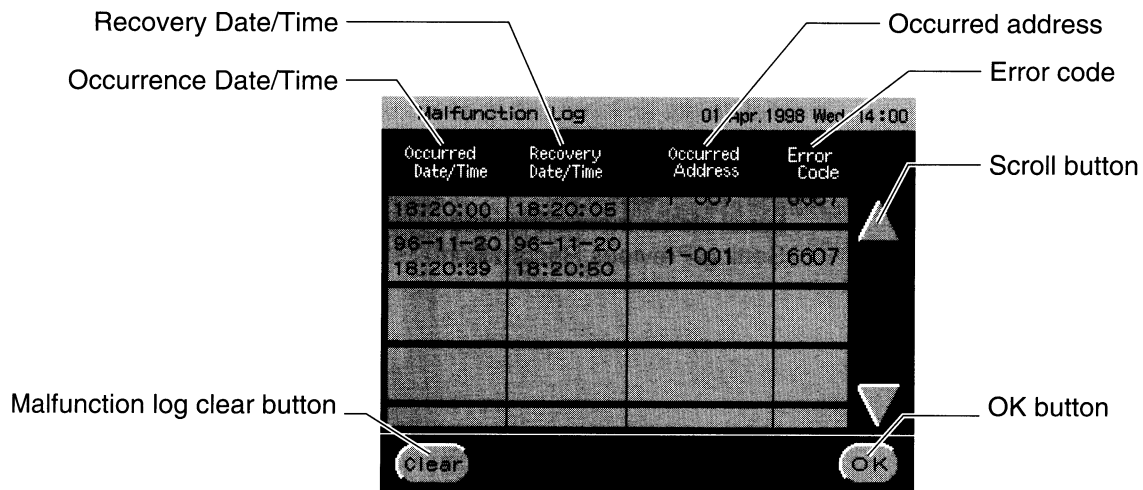

Item	Details
Scroll button	Scrolls the screen up and down.
Occurred Date/Time	Displays the date and time that the malfunction occurred.
Recovery Date/Time	Displays the date and time that the malfunction was reset.
Occurred address	Displays the system number and the address of the unit in which the abnormality has occurred. ([System number] - [Unit address]) Example: The display will be as follows when an abnormality occurs in a unit in system #1 with an address of 20: 1-020
Error Code	4-digit number displays the malfunction description.
Malfunction log clear button	Deletes all malfunction log entries.
OK button	Returns to the operation condition monitoring screen.

# 8. Troubleshooting

## 8-1. When the screen becomes soiled

- Clean the screen in accordance with the following directions when it becomes soiled.

The Operation Condition Monitoring Screen.

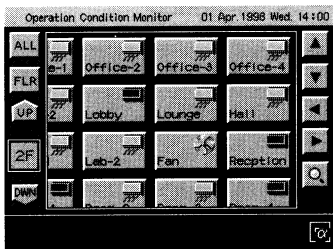

- ① Touch the  button on the bottom right-hand side of the operational status monitoring screen to move across to the All Kinds Of Setting/Previous Record Screens.



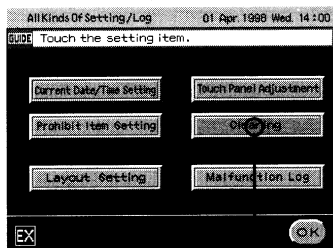

The All Kinds Of Setting / Previous Record Screen.

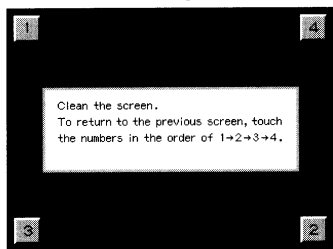

- ② Touch the “Cleaning” button and move to the  Screen.

The Cleaning Screen.



- ③ Once the screen has been wiped, touch the , ,  and  buttons in sequence to return to The All Kind Of Setting / Previous Record Screen.

The All Kinds Of Setting / Previous Record Screen.

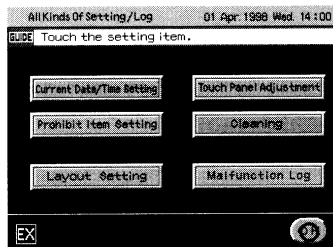

The Operation Condition Monitoring Screen.

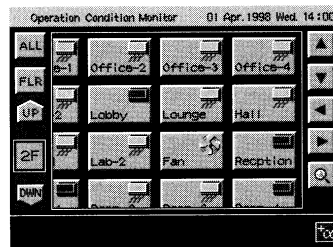

**NOTE:**

- If the screen surface becomes soiled, wipe it lightly with a soft cloth which has been wet slightly with ethanol.
- Do not wipe the screen surface with water.

## 8-2. During power cuts

- Schedule data, layout data and the other settings are stored and will not be erased for a certain period of time even during power cuts.
- The system will automatically start up in the same condition as it was before the power cut occurred when the power is restored. The operations of this function are as follows.

The Start Up Screen.

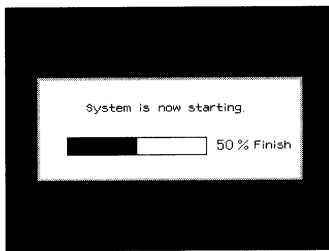

- ① The system is started up automatically when the power is restored.

The Operation Condition Monitoring Screen.

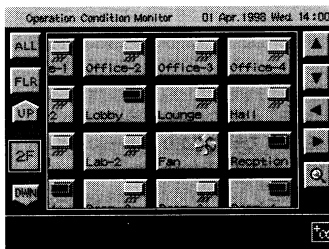

- ② The Operation Condition Monitoring Screen will be displayed when the start-up process is complete. Normal operations can be performed once The Operation Condition Monitoring Screen has been displayed.

**NOTE:**

- \* Schedule, layout and other data settings will be written into the internal flash memory at a pre-determined time to prevent the data from being lost during power cuts. However, as the current time will only be backed up for approximately one week, it is necessary to reset the current time (p.41) during start-up if the power supply is to be switched off for more than one week.
- All remote controllers will be permit for manual operations in the event of a power cut. If Prohibit/Permit settings are required, perform this procedure once more on the operation content operation screen (p.7). Once the Prohibit/Permit items have been set in the schedule (p.28), they will be automatically set when the scheduled time arrives after recovery following a power cut.

## 9. Specifications

Item	Specification	
Rated voltage	Input voltage	AC220V to AC240V, 0.3A (maximum)
	Fuse	2.0A Fast Break Type. (IEC 127-2 S.S.2)
Transmission line interface	M-NET transmission line : DC30V+AMI signal. Main bus transmission line : AMI signal	
Environment conditions	Temperature	Operating temperature : 0 to +40 °C Storage temperature : 0 to +60 °C
	Humidity	30 to 90% RH (with no condensation)
External dimensions (H × W × D)mm	480 × 360 × 100	
Weight	9kg	
Clock Accuracy	±50 seconds/month	

# 10. List of error codes

Error code	Meaning	Error code	Meaning
0110.	Equipment abnormality error	4200.	General inverter abnormality
0120.	Equipment abnormality error	420*.	General inverter abnormality. Inverter number
0900.	Test run	4210.	General inverter overcurrent shutdown abnormality
1000.	General coolant system abnormality	421*.	Inverter overcurrent shutdown. Inverter number
10*0.	Coolant system abnormality * Entire system	4220.	General insufficient inverter bus bar voltage abnormality
11**.	Coolant system temperature abnormality. Regional common operand **	422*.	Insufficient inverter bus bar voltage. Inverter number
12**.	Coolant system temperature abnormality delay. Regional common operand **	4230.	General inverter radiator thermo abnormality
13**.	Coolant system pressure abnormality. Regional common operand **	423*.	Inverter radiator thermo abnormality. Inverter number
14**.	Coolant system pressure abnormality delay. Regional common operand **	4240.	General inverter overcurrent protect abnormality
1500.	Coolant system prohibited. Coolant overcharge	424*.	Inverter overcurrent protect abnormality. Inverter number
1501.	Coolant system prohibited. Insufficient coolant	4250.	General inverter IPM abnormality
1502.	Coolant system prohibited. Liquid backed up	425*.	Inverter IPM abnormality. Inverter number
1503.	Coolant system prohibited. Frozen	4300.	General inverter abnormality delay
1504.	Coolant system prohibited. Overflow protect	430*.	General inverter abnormality delay. Inverter number
1505.	Coolant system prohibited. Compressor vacuum protect	4310.	General inverter overcurrent shutdown abnormality delay
2000.	General water system abnormality	431*.	Inverter overcurrent shutdown abnormality delay. Inverter number
20*0.	Water system abnormality * Entire system	4320.	General insufficient inverter bus bar voltage delay
21**.	Water system temperature abnormality. Regional common operand **	432*.	Insufficient inverter bus bar voltage delay. Inverter number
22**.	Water system abnormality delay. Regional common operand **	4330.	General inverter radiator thermo abnormality delay
23**.	Water system pressure abnormality. Regional common operand **	433*.	Inverter radiator thermo abnormality delay. Inverter number
24**.	Water system pressure abnormality delay. Regional common operand **	4340.	General inverter overcurrent protect abnormality delay
2500.	Water system prohibited. Leakage	434*.	Inverter overcurrent protect abnormality delay. Inverter number
2501.	Water system prohibited. Water cutoff	4350.	General inverter IPM abnormality delay
2502.	Water system prohibited. Drain pump abnormality	435*.	Inverter IPM abnormality delay. Inverter number
2503.	Water system prohibited. Drain sensor abnormality	5000.	General sensor fault
2504.	Water system prohibited. Water level abnormality	50*0.	Sensor fault * Entire system
2505.	Water system prohibited. Cold water electric valve abnormality	51**.	Temperature sensor fault. Sensor number **
2506.	Water system prohibited. Hot water electric valve abnormality	52**.	Pressure sensor fault. Sensor number **
2600.	Water system restricted. Leakage	53**.	Current sensor fault. Sensor number **
2601.	Water system restricted. Water cutoff	54**.	Humidity sensor fault. Sensor number **
2602.	Water system restricted. Drain pump abnormality	55**.	Gas sensor fault. Sensor number **
2603.	Water system restricted. Drain sensor abnormality	56**.	Fan speed sensor fault. Sensor number **
2604.	Water system restricted. Water level abnormality	57**.	Limited switch sensor fault. Sensor number **
3600.	Air system restricted. Filter blockage	58**.	Sensor fault. Sensor number **
3601.	Air system restricted. Filter maintenance	59**.	Other sensor fault. Sensor number **
3602.	Air system restricted. Damper position detection abnormality	6000.	General system abnormality
37**.	Air system temperature abnormality delay. Regional common operand **	6101.	System prohibited. With response frame
4000.	General electrical system abnormality	6102.	No answerback
40*0.	Electrical system abnormality * Entire system	6500.	General communication abnormality
4100.	Electrical system prohibited. Overcurrent shutdown	6600.	Communication abnormality. Duplicate address definition error
4101.	Electrical system prohibited. Overcurrent protect	6601.	Communication abnormality. Polarity not set error
4102.	Electrical system prohibited. Open phase	6602.	Communication abnormality. Transmission processor. Hardware error
4103.	Electrical system prohibited. Inverted phase	6603.	Communication abnormality. Transmission route BUSY error
4104.	Electrical system prohibited. Electrical leak	6604.	Communication abnormality. No ACK (06H) error
4105.	Electrical system prohibited. Short circuit	6605.	Communication abnormality. No response frame
4106.	Electrical system prohibited. Auto-power OFF	6606.	Communication abnormality. Communication abnormality with the transmission processor
4107.	Electrical system prohibited. Overload	6607.	Communication abnormality. ACK not returned error
4108.	Electrical system prohibited. OCR51C	6608.	Communication abnormality. Response frame not returned error
4109.	Electrical system prohibited. OCR51F	6609.	Communication abnormality.
4110.	Electrical system prohibited. High-voltage section	6610.	Communication abnormality.
4111.	Electrical system prohibited. Bus bar current	6700.	Communication abnormality. General K transmission abnormality
4112.	Electrical system prohibited. Coil overheat 49 degrees Celsius	6701.	Communication abnormality. K transmission error
4113.	Electrical system prohibited. Heater overheat	6702.	Communication abnormality. Duplicate K address definition error
4114.	Electrical system prohibited. Fan controller abnormality	6750.	Communication abnormality. K abnormality code PO
4115.	Electrical system prohibited. Power synchronization abnormality	6751.	K abnormality. Intake sensor abnormality
4116.	Electrical system prohibited. Motor abnormality	6752.	K abnormality. Pipe sensor error. Compressor temperature detection sensor abnormality

Error code	Meaning	Error code	Meaning
6753.	K abnormality. Send/receive error	6810.	Communication abnormality. General UR communication abnormality
6754.	K abnormality. Drain sensor abnormality. Floating switch activated	6811.	Communication abnormality. Unrecoverable UR communication synchronization abnormality
6755.	K abnormality. Drain pump abnormality	6812.	Communication abnormality. UR communication hardware error
6756.	K abnormality. Freeze/overheat protect	6813.	Communication abnormality. UR communication status bit detection error
6757.	K abnormality. System error	6820.	Other communication abnormality.
6758.	K abnormality. Outdoor unit abnormality. Indoor/outdoor communication error	6821.	Other communication abnormality. Transmission route BUSY
6761.	K abnormality. Intake sensor abnormality	6822.	Other communication abnormality. No communication ACK
6762.	K abnormality. Pipe sensor abnormality. Compressor temperature detection sensor abnormality	6823.	Other communication abnormality. No response command
6763.	K abnormality. Send/receive error	6824.	Other communication abnormality. Received data error
6764.	K abnormality. Drain sensor abnormality	7000.	General system abnormality
6765.	K abnormality. Drain pump abnormality	7100.	System abnormality. Total capacity error
6766.	K abnormality. Freeze/overheat protect	7101.	System abnormality. Capacity code error
6767.	K abnormality. Outdoor unit abnormality. Indoor/outdoor communication error	7102.	System abnormality. Too many connected units
6771.	K abnormality. High-pressure abnormality. Low pressure abnormality	7103.	System abnormality. Incorrect pipe length setting
6772.	K abnormality. Inner thermo activated. Discharge temperature abnormality. Other	7104.	System abnormality. Incorrect floor setting
6773.	K abnormality. Radiation board thermo abnormality	7105.	System abnormality. Address setting above 255
6751.	K abnormality. Intake sensor abnormality	7106.	System abnormality. Attribute setting error
6752.	K abnormality. Pipe sensor abnormality. Compressor temperature detection sensor abnormality	7107.	System abnormality. Distribution outlet setting error
6774.	K abnormality. Outdoor thermistor abnormality	7108.	System abnormality. Coolant system setting error
6775.	K abnormality. Pressure sensor abnormality. Indoor/outdoor communication abnormality	7109.	System abnormality. Connection setting error
6776.	K abnormality. Overcurrent shutdown	7110.	System abnormality. Connection information not set error
6777.	K abnormality. System error	7111.	System abnormality. Input/output device not connected
6778.	K abnormality. Normal	7112.	System abnormality. Input/output type setting abnormality
6779.	K abnormality. Coolant overcharge	7113.	System abnormality. Device not set
6800.	Communication abnormality. Other general communication abnormality	7200.	System abnormality. General value not set
6801.	Communication abnormality. V control communication abnormality.	7201.	System abnormality. Value not set

This product is designed and intended for use in the residential,  
commercial and light-industrial environment.

The product at hand is based on the following EU regulations:

- Low Voltage Directive 73/23/EEC
- Electromagnetic Compatibility Directive 89/336/EEC