

Mitsubishi Electric Building Air Conditioning Control System

System remote controller PAC-SF41SCA

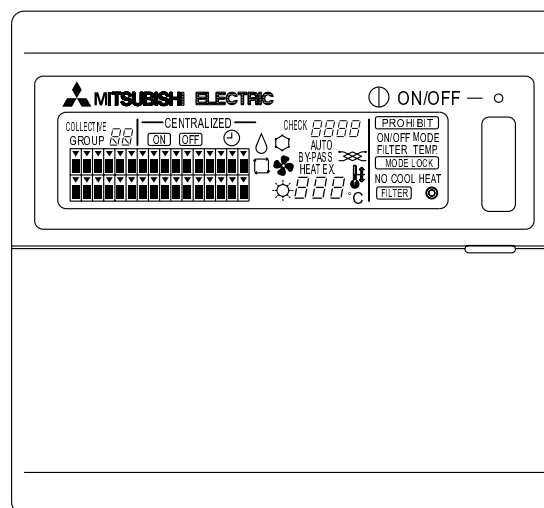

GB

D

F

E

I

NL

INSTRUCTION BOOK

Carefully read this book before use. It is recommended to safe keep this book for future reference.

ANWEISUNGSHANDBUCH

Vor Benutzung der Anlage dieses Buch sorgfältig durchlesen. Es wird empfohlen, dieses Buch zum Nachschlagen an einem sicheren Ort aufzubewahren.

MANUEL D'UTILISATION

Lire attentivement le présent manuel avant toute utilisation et le conserver dans un endroit sûr pour pouvoir le consulter ultérieurement.

LIBRO DE INSTRUCCIONES

Lea cuidadosamente este libro antes de usar el temporizador. Le recomendamos que guarde el libro en lugar seguro en previsión de consultas futuras.

LIBRETTO ISTRUZIONI

Leggere attentamente questo libretto prima dell'uso. Si raccomanda di tenerlo in un luogo sicuro per ogni futura necessità.

INSTRUCTIEHANDLEIDING

Lees deze handleiding aandachtig door voordat u het apparaat in gebruik neemt. Het wordt aangeraden om deze handleiding zorgvuldig te bewaren om later, indien nodig, te raadplegen.

CONTENTS

Page

1. Safety precautions	2
Symbols and terms	2
Specific precautions	3
2. Functions	4
3. The names of indicators and their functions	6
4. Operation	8
4-1. Collective operation screen	8
4-2. Group operation screen	9
4-3. Setting	10
5. Emergency stop mode	13
6. When a malfunction occurs	13
7. Initial settings	14
7-1. Setting from the master system controller	14
7-1-1. Setting the number of the minimum management group	15
7-1-2. Group settings	16
7-1-3. Setting up interlocked units	19
7-1-4. Collective deletion of registration details	22
7-2. When managed with the master system controller	22
7-3. Emergency stop mode setting	23
8. Specifications	23
Specifications for this equipment	23



1. Safety precautions

Please take a moment to review these safety precaution. They are provided for your protection and to prevent damage to the controller.

This safety information applies to all operators and service personnel.

After you have read this manual, always observe the procedures described in the explanations and store it with the installation manual in a location that is easy to find. If the controller is going to be operated by another person, make sure that this manual is given to him or her.

Symbols and terms

 WARNING	Statements identify condition or practices that could result in personal injury or loss of life.
 CAUTION	Statements identify condition or practices that could result in damage to the controller or other property.

Specific precautions

WARNING

- Ask your dealer or technical representative to install.
 - If incorrect installation is done by a customer, it may cause an electric shock, fire, etc.
- Securely install in a place which can withstand the weight of the controller.
 - If it is not enough, the controller may drop and cause an injury.
- Make sure that the controller is connected to a rated power supply.
 - If the controller is not connected to a rated power supply, it may cause a fire or damage to the controller.
- Never remove the cover during operation.
 - Touching the charging parts of the controller may cause severe burns or other personal injury.
- Stop the operation if any malfunction occurs.
 - If malfunction occurs (burning smell, etc.) stop the operation and turn off the power supply. Contact the your dealer or technical representative immediate. If the controller continues to operate after a malfunction occurs, this may cause damage, electric shock or fire.
- Do not move and re-install the controller by yourself.
 - If installation is incorrect, it may cause an electric shock, fire, etc. Ask your dealer or technical representative.
- To dispose of this product, consult your dealer.
- Do not remodel or repair by yourself.
 - If the controller is remodeled or repair is not correct, it may cause an electric shock, fire, etc. Consult your dealer if repair are necessary.
- Stop the operation immediately and notify the your dealer if an error code is displayed or malfunction occurs.
 - Fire or damage may cause it the controller is operated in this condition.

CAUTION

- Do not install the controller in a place where inflammable gas could leak.
 - If gas leaks and collects around the controller, it may cause a fire or explosion.
- Do not wash the controller with water.
 - It may cause an electric shock or malfunction.
- Do not touch the switch with wet hands.
 - It may cause an electric shock.
- Do not use the controller for special applications.
 - This product is designed for use with the MITSUBISHI ELECTRIC BUILDING AIR CONDITIONING CONTROL SYSTEM. Do not use the system for other air condition management operation or applications. It may cause malfunctions.
- Do not apply insecticide or flammable sprays to the controller.
 - Do not place flammable spray near the controller and make sure it does not blow directly on the controller as this may cause in fire.
- Do not use the controller in special environments.
 - The performance may be reduce or parts may be damaged if the controller is used in locations subject to large quantities of oil (including machine oil), steam, sulfide gas.
- Do not touch the switches with sharp objects.
 - It may cause an electric shock or malfunction.
- Operate the controller within the specified temperature range.
 - Observe the specified temperature range when operating the controller. If the controller is used outside the specified temperature range, it may cause serious damage. Be sure to check the operation temperature range in the operation manual.
- Do not pull or twist the transmission line.
 - It may cause a fire or malfunction.
- Do not dismantle the unit.
 - It is dangerous to touch the internal circuit board. It may cause a fire or malfunction.
- Do not clean the unit using benzene, thinner or other chemicals.
 - It may cause discoloration or other damage. If the unit should become particularly dirty, apply a mild cleaner that has been diluted with water to a soft cloth and wipe the unit clean. Be sure to wipe away any residual moisture with a dry cloth.

2. Functions

This unit can control a maximum of 50 air conditioner units. The operation listed below are also possible.

<List of system remote controller functions>

		Item	Specification
User operating function	Operations	ON/OFF	ON/OFF operations for the collective or each group.
		Operation mode	Set the operating mode for the collective or each group. Indoor unit: Cooling/Dry/Fan/Auto/Heating Ventilation unit: AUTO/BY-PASS/HEAT EX.
		Temperature setting	Sets the temperature for the collective or each group. Range of temperature settings $\left(\begin{array}{l} \text{Cool/Dry operations : } 19\text{ }^{\circ}\text{C to } 30\text{ }^{\circ}\text{C} \\ \text{Heat operations : } 17\text{ }^{\circ}\text{C to } 28\text{ }^{\circ}\text{C} \\ \text{Auto operations : } 19\text{ }^{\circ}\text{C to } 28\text{ }^{\circ}\text{C} \end{array} \right)$
		Timer operation	Switches between activating and suspending scheduled operations that use a program timer (sold separately) for the collective or each group.
		Local remote controller prohibition	Allows the following collective or group operations to be prohibited: local remote controller ON/OFF, operation mode, set temperature, filter reset. (Only when PAC-SF41SCA is set as the master system controller.)
		Operation mode switching limitation (season switching)	Allows limitation of switching the collective operation modes for the main unit and local remote controller: COOL (winter), HEAT (summer), COOL HEAT (between seasons).
		Filter reset	Resets the filter sign after the filter has been cleaned for the collective or each group.
	Monitoring	Collective operation	The overall status lamps display condition of the collective status.
		Each group operation	Liquid crystal display
		Operation mode	
		Temperature settings	
		Timer operation	
		Filter sign	
		Prohibition	
		Main unit prohibition	
Operation mode switching limitation			
Malfunction	Displays the unit address of the malfunction unit and the error code on the liquid crystal display		
Initial setting functions	Operations	Group settings	Performs the group settings for the unit (indoor unit, remote controller, slave system controller)
		Interlocked settings	Performs the interlocked settings for ventilation unit.
		Set the number of the minimum management group	Set the number of the minimum management group managed by this unit.
	System	Master system controller/slave system controller (*1)	Master and slave settings for the system controller.
		System remote controller's address	Address setting for the system remote controller.
System control	Number of control unit	Indoor unit	Maximum 50 (maximum 32 groups)
		Number of indoor units in one group	0 to 16 (Indoor units and ventilation units cannot be registered in the same group.)
		Number of remote controllers in one group	0 to 2
		Number of system controllers in one group	0 to 4 (including the number of remote controller in one group) 0 to 3 for which have one remote controller.
		Number of indoor units interlocked with one ventilation unit	0 to 16 (some type of ventilation unit can be only operate when interlocked to a maximum of 9 units)

Item		Specification
Other	Emergency stop	Enables external input to this unit of emergency stop, which turns off overall air conditioning and Lossnay and allows prohibition of remote controller operation, including main unit.

*1 Master system controllers and slave system controller

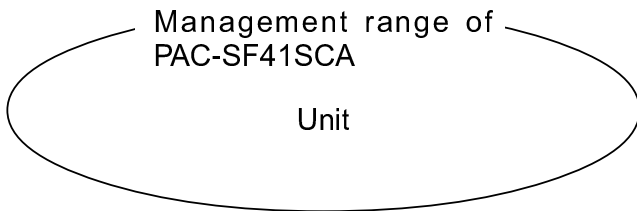

When using a system consisting only of PAC-SF41SCA. PAC-SF41SCA is set as the master system controller. In this case, the group settings are performed with PAC-SF41SCA.

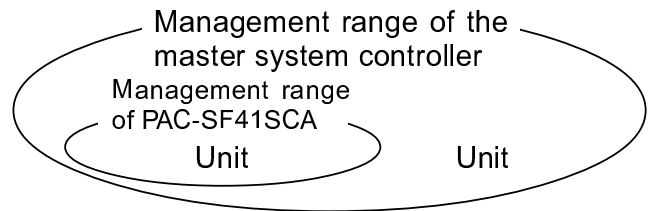

When using a system where PAC-SF41SCA is controlled by a different system controller. PAC-SF41SCA is set as the slave system controller. In this case, the group settings are not performed with PAC-SF41SCA.

GB

NOTE: It is not possible to set the master and slave settings with more than one group remote controller and control the same groups. Also, the groups listed below cannot be set.

- Unit group which are not under the management of the master controller and are managed by the slave system controller.

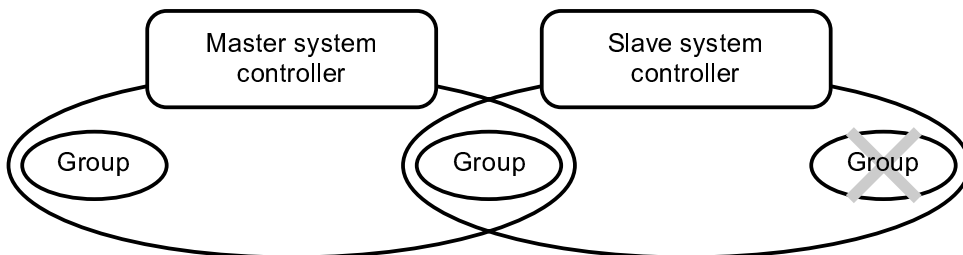

- A common group is managed by more than two master controllers.

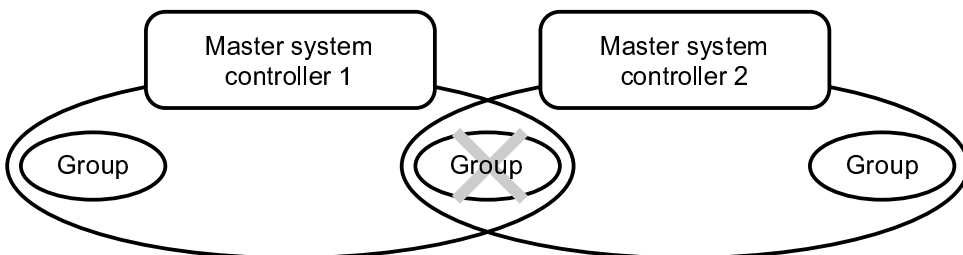

- A slave system controller which exceeds the management range of the master system controller of two or more.

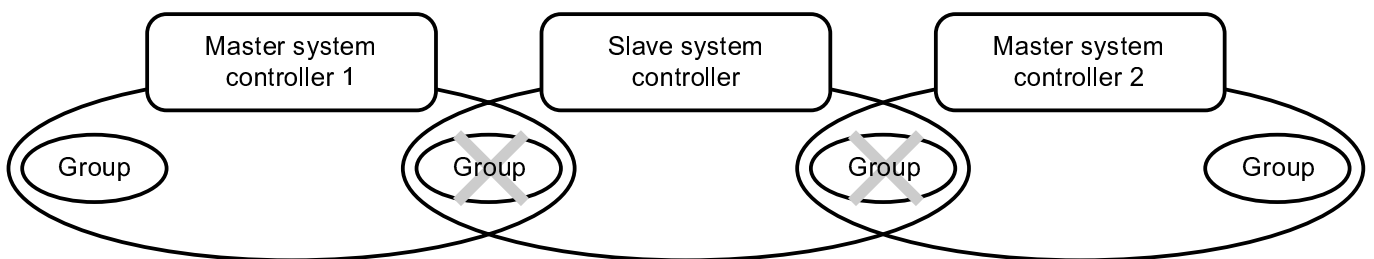

3. The names of indicators and their functions

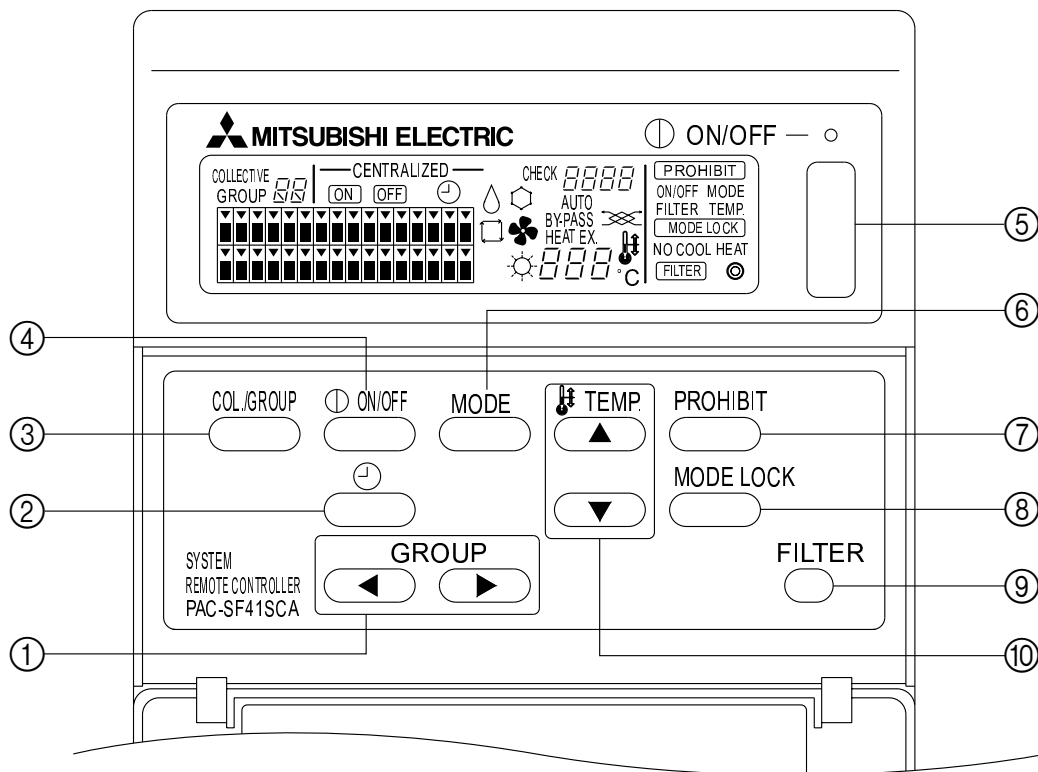

- ① GROUP SELECT SWITCH:
Used to call out the group.
- ② EXT ERNAL TIMER SWITCH:
Allows you to select the TIMER MODE when the PRO-
GRAM TIMER (option) has been installed.
- ③ COLLECTIVE/GROUP SWITCH:
Used to call out collective operation screen and group
operation screen.
- ④ ON/OFF SWITCH:
Used to switch between ON/OFF for the selected group.
- ⑤ COLLECTIVE ON/OFF SWITCH:
Allows you switch between ON/OFF for all groups.
- ⑥ OPERATION MODE SWITCH:
Used to select the operation mode.
- ⑦ PROHIBIT SWITCH:
Used to set the prohibition for local remote controller.
- ⑧ OPERATION MODE LOCK SWITCH:
Used to limit switching of this unit and local remote con-
troller operation modes for each season.
- ⑨ FILTER SIGN RESET SWITCH:
Used to reset the filter sign.
- ⑩ TEMPERATURE SETTING SWITCH:
Used for changing the temperature setting.

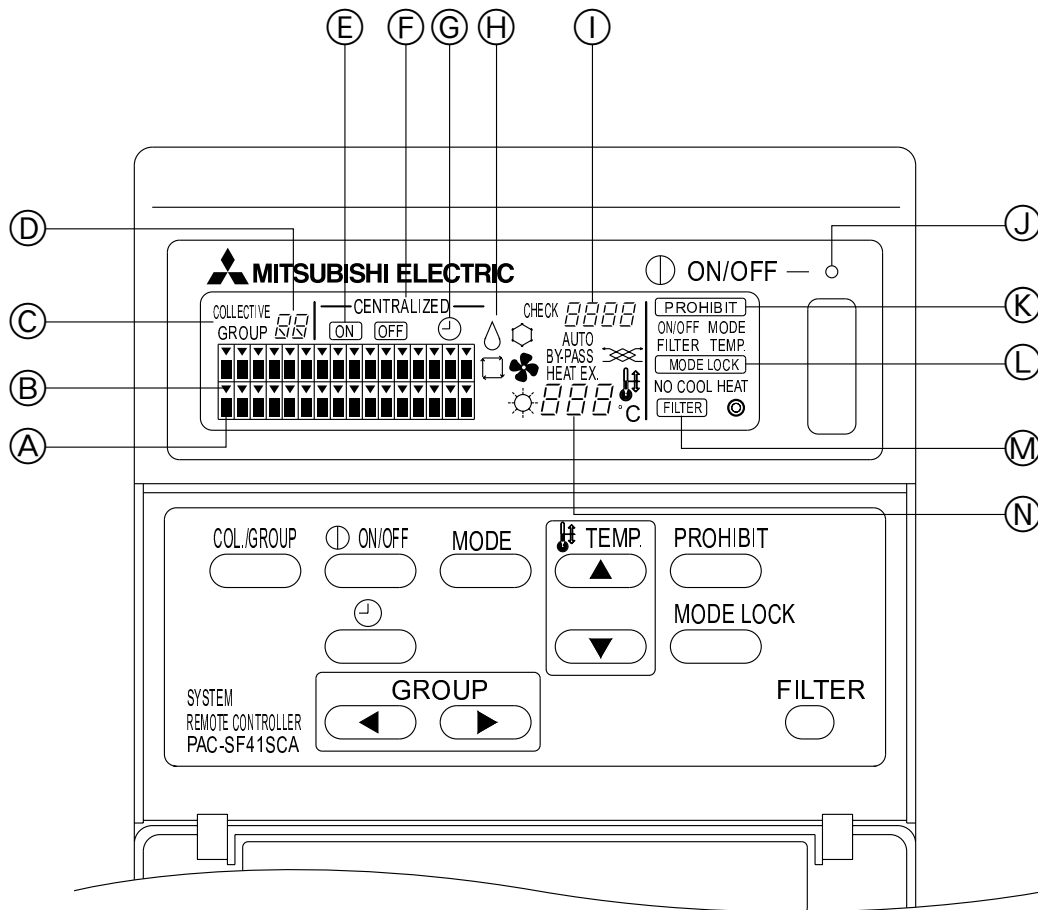

Ⓐ GROUP OPERATION STATUS DISPLAY:

ON : Run
 OFF : Stop
 BLINK: Malfunction

Ⓑ GROUP SELECTION DISPLAY:

Display the position of the selected group. All registered groups are displayed on collective operation screen.

Ⓒ COLLECTIVE/GROUP DISPLAY:

COLLECTIVE is displayed when operating for all registered groups.
 GROUP is displayed when operating for individual group.

Ⓓ GROUP NUMBER DISPLAY:

Display the selected group number.

Ⓔ ON/OFF DISPLAY FOR INDIVIDUAL GROUP:

Display the ON/OFF status of selected group.

Ⓕ CENTRALIZED DISPLAY:

Indicate under prohibited the operation by the master system controller.

Ⓖ TIMER OPERATION DISPLAY:

Display when the PROGRAM TIMER (sold separately) is installed and the TIMER MODE is set.

Ⓗ OPERATION MODE DISPLAY:

Display the current operation mode.

Ⓘ ERROR CODE DISPLAY:

Display the error code when malfunction is occurred.

Ⓙ OVERALL STATUS LAMP:

The lamp indicates the unit operation condition.
 ON : One or more group run.
 OFF : All groups stopped.
 BLINK: Malfunction occurred.

Ⓚ OPERATION PROHIBITION DISPLAY:

Display when prohibition for local remote controller is set.

Ⓛ OPERATION MODE SWITCHING LIMITATION DISPLAY:

Shows when switching between specified operation modes is limited.

Ⓜ FILTER SIGN DISPLAY:

Blink when the filter requires cleaning.

Ⓝ TEMPERATURE SETTING DISPLAY:

Display the current temperature setting.

4. Operation

4-1. Collective operation screen

Collective operation screen

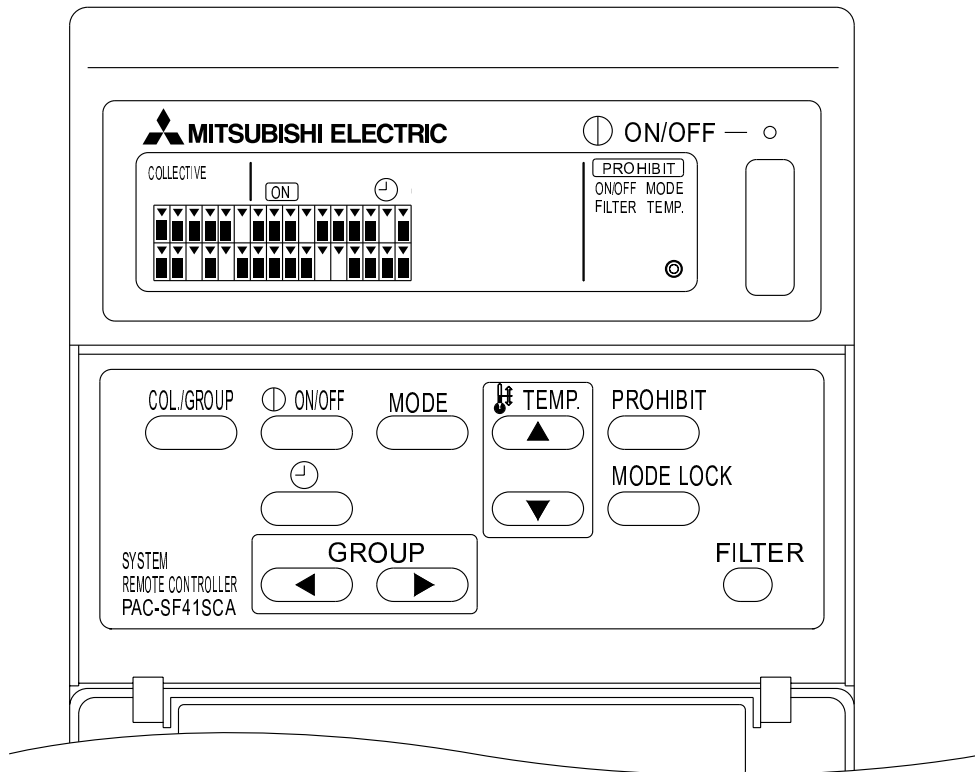

When [COLLECTIVE] is displayed, all groups managed with the system remote controller may be operated collectively as follows.

- ON/OFF for indoor and ventilation units.
- Operating mode for indoor and ventilation units.
- Temperature setting for indoor units.
- Timer operation switching.
- Filter sign reset.
- Disable the local remote controller (only with master settings).
- Setting function for switching limitation of this unit and local remote controller operation modes for each season.

Pressing the  switch with operation settings for each group displays the group operation screen.

(The operation mode and the set temperature displays disappear after switching from the group operation screen to the collective operation screen. If the operation mode switch or temperature setting switch is used, the details are displayed. Ten minutes after setting is complete, the operation mode and set temperature display go off. If the operation mode switching limitation is turned on while the operation mode message is displayed on this screen, the message disappears.)

4-2. Group operation screen

The group operation screen

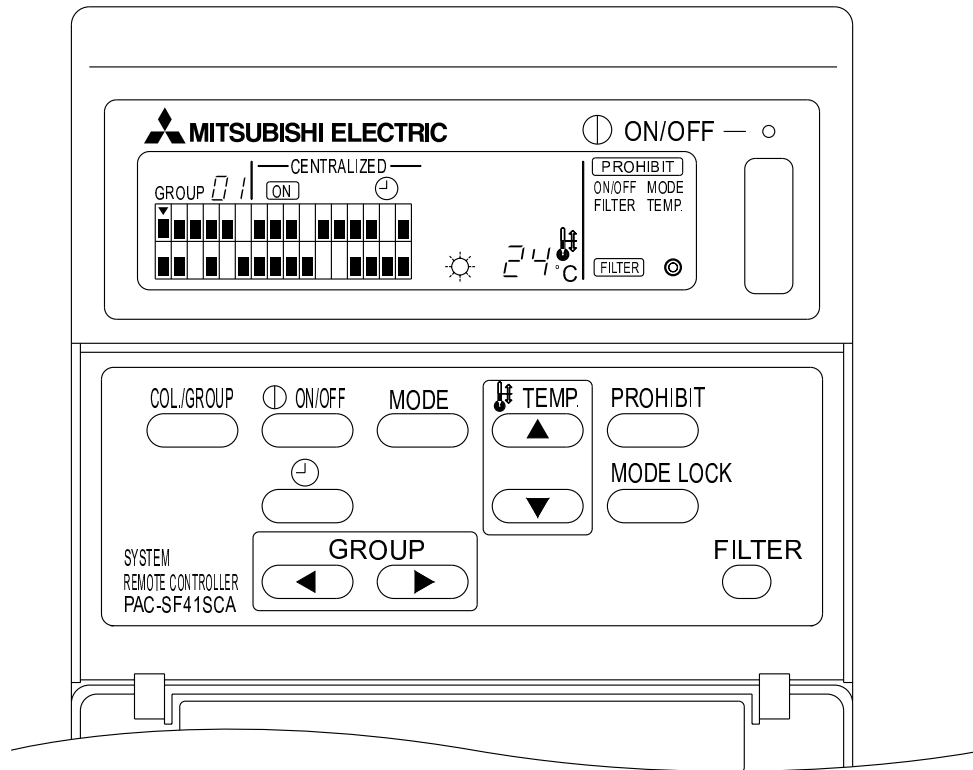

The following operations are possible for the selected group when [GROUP] is displayed.

- ON/OFF for indoor and ventilation units.
- Operating mode for indoor and ventilation units.
- Temperature setting for indoor units.
- Timer operation switching.
- Filter sign reset.
- Disable the local remote controller (only with master settings).

* Collective ON/OFF is possible for all groups when the COLLECTIVE ON/OFF switch is used in the group operation screen.

The group to be used is selected with the GROUP (◀, ▶) switch.

Pressing the  switch selects the collective operation screen when all groups are to be used collectively.

(The system returns to the collective operation screen automatically if nothing is entered on the group operation screen for a period of ten minutes.)

	Temperature range
Cool/Dry	19 to 30 °C
Heat	17 to 28 °C
Auto	19 to 28 °C

The temperature cannot be adjusted in the Fan mode.

The temperature cannot be adjusted for a ventilation unit group.

(4) Prohibiting the local Remote Controller

This setting is only possible with a master system controller.

[Collective Operation Screen]

Prohibit settings of all registered local remote controllers.

[Group Operation Screen]

Prohibit settings of local remote controllers in selected groups.

<Making Settings>

- ① PROHIBIT, ON/OFF, <MODE>, <TEMP.>, and FILTER blink in sequence each time the PROHIBIT switch is pressed.
- Items already prohibited on the group operation screen are lit (all blink on the collective operation screen).
 - The item in < > is not displayed while a ventilation unit group is selected.

- ② The following switches are used to prohibit or permit items for the local remote controller.

ON/OFF switch: Prohibit or permit ON/OFF.

MODE switch: Prohibit or permit mode select.

FILTER switch: Prohibit or permit filter reset.

TEMP. switch (▲, ▼): Prohibit or permit temperature setting.

* Enable/Disable Display

ON : Prohibit

OFF : Permit

BLINK: Not yet set

The switches toggles between Lit and Extinguished each time it is pressed.

- ③ Press the PROHIBIT switch to check whether each setting is permitted or prohibited.
- PROHIBIT is lit for a prohibited item.
 - All items blink during operation on the collective operation screen. None are permitted, and the prohibited status of each group continues.

NOTE: PROHIBIT cannot be selected for MODE and TEMP. with ventilation unit groups.

(5) Operation mode switching limitation (season switching)

[Collective Operation Screen]

Limits switching between specified operating modes for the this unit and the local remote controllers for all groups.

For example, the selection can be limited to suit the season: COOL (winter), HEAT (summer), COOL HEAT (between seasons).

[Group Operation screen]

Cannot be set by this screen.

To set, use the Collective Operation Screen.

Each time the [MODE LOCK] switch is pressed, the displays for the mode to be prohibited light up in the following order.

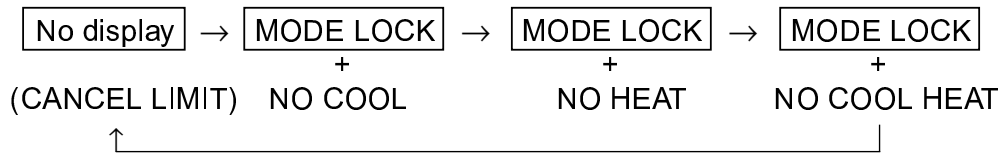

When NO COOL is selected: Cool, Dry and Auto modes cannot be selected using the Operation mode switch

When NO HEAT is selected: Heat and Auto modes cannot be selected using the Operation mode switch

When NO COOL and NO HEAT are selected: Cool, Dry, Heat and Auto modes cannot be selected using the Operation mode switch (only Fan can be selected).

When CANCEL LIMIT (does not light up) is selected: Limitation is canceled

NOTICE: When operation mode switching of this unit is limited using another controller, the above settings cannot be made on this unit. These functions are not available on some indoor units. In these cases, operation mode switching cannot be limited using the local remote controller.

(6) External Timer

[Collective Operation Screen]

The external timer toggles between valid and invalid each time the  switch is pressed.



[Group Operations Screen]

The external timer toggles between valid and invalid for the selected group each time the  switch is pressed.

* If the external timer is valid the  is lit and operation is switched ON/OFF in accordance with the program timer (sold separately).

* If the external timer is not connected the timer blinks and the timer cannot be set.

(7) Filter Sign Reset

 and the relevant group select display () blinks when the filter is due for cleaning.

Reset the filter sign after replacing the filter by following the below operation.

[Collective Operation Screen]

Press the  switch twice to extinguish the  (blinking) and reset the filter signs for all groups.

[Group Operations Screen]

Press the  switch twice to extinguish the  (blinking) and reset the filter signs for the selected groups.

5. Emergency stop mode

- All registered indoor units and ventilation units are stopped when emergency stop input is received at the external input pin. All units, including the system remote controller, are prohibited until this emergency stop input is cleared.
- Except for the ON/OFF status, the system returns to the status prior to the emergency stop input being received when the emergency stop input is cleared.

Screen During Emergency Stop Input

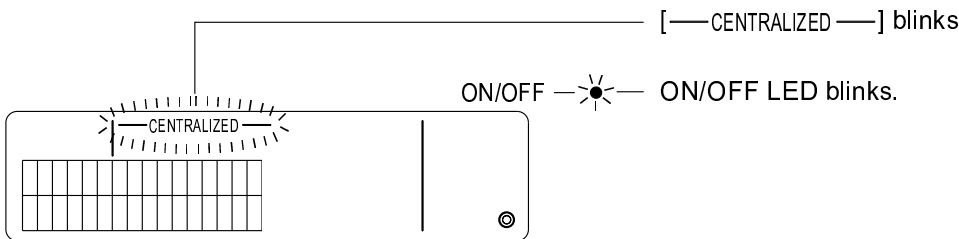

NOTE: The emergency stop input and the external timer cannot be used together. Select which of these two functions is to be valid when making the initial settings (the external timer is the default when shipped). When setting, refer to 7-3 Emergency Stop Mode Setting.

6. When a malfunction occurs

The details of a malfunction are displayed on the screen below.

Note the address of the malfunction and the error code, and contact your dealer or service center.

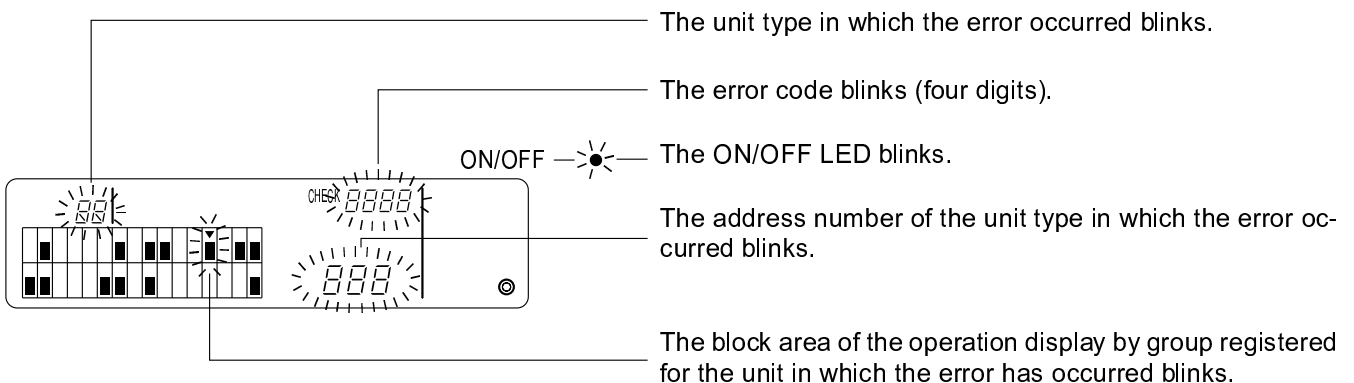

- NOTE:**
- When an error occurs in a group not selected the ON/OFF LED, and the group operation status display (■) for the group in which the error occurred, blink on the group operation screen. In this case, select the group in which the error has occurred using the group select switch, and check the error details.
 - When errors occur in multiple groups the details of the error are displayed on the collective operation screen for the lowest group number. To check the error details for other groups, press the COL.GROUP switch, and select the desired group with the GROUP switch (◀, ▶).

Clearing Errors

To clear all errors at once: Press the COLLECTIVE ON/OFF switch.

To clear errors for each group: Select the desired group and press the ON/OFF switch.

7. Initial settings

7-1. Setting from the master system controller



Initial settings are as follows.

- Own address display
- Number of the minimum management group
- Group settings
- Setting up interlocked units
- Collective deletion of registration details

In order to perform these operations, first of all move to the Initial Setting Mode.



(1) Moving to the Initial Setting Mode

- When group information is not registered in the system remote controller

[H0] is displayed, and the ON/OFF LED blinks, when power is supplied. In this condition, press the  and TEMP.  switches simultaneously.

- When group information is registered in the system remote controller

[H1] is displayed, and the ON/OFF LED blinks, when power is supplied, and the group operation/monitor screen appears.

In this condition, press the  and TEMP.  switches simultaneously.

CAUTION: When one or more groups within the registered group are in operation, or if any unit is malfunctioning, the operation described above cannot be used to move to select the initial setting mode. Enter the initial settings after using the COLLECTIVE ON/OFF switch to stop all registered units.

When the initial setting mode is selected the own address of the system remote controller blinks for two seconds, and the initial setting screen then appears.

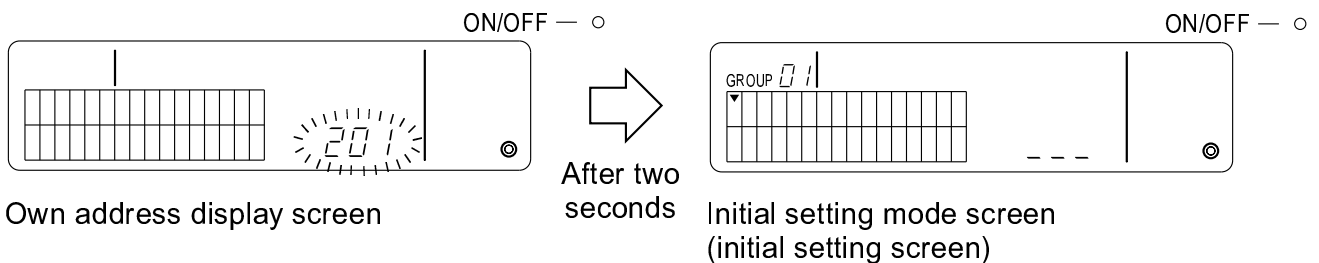

(2) Clearing the Initial Setting Mode

After registration is complete, press the  and TEMP.  switches simultaneously. Re-start the system after the initial setting mode has been cleared.

CAUTION: Cutting power supply while [H1] is blinking during system start-up communication will result in information such as group settings not being saved correctly.

7-1-1. Setting the number of the minimum management group

Sets the number of the minimum management group using the system remote controller.
(The minimum management group = 1 is set when shipped.)

Groups managed with the system remote controller.

Groups between the minimum management group number and the minimum management group + 31.

Examples: Groups 1 - 32 are managed when the minimum management group = 1.

Groups 12 - 43 are managed when the minimum management group = 12.

The minimum management group number set with this function appears as a group number in the block at the top-left of the display.

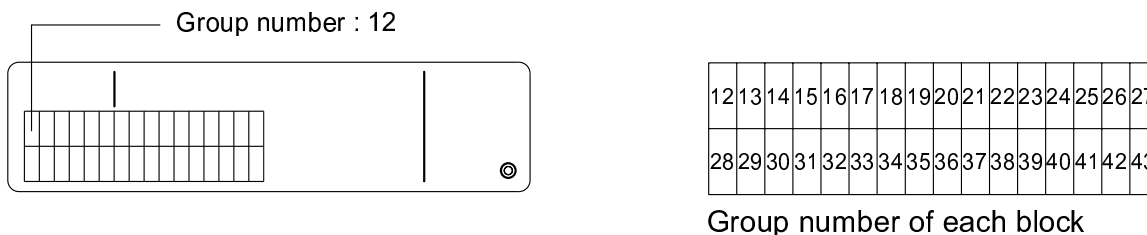

Example: When the minimum management group = 12



Changing the Minimum Management Group Number

(1) Press the  switch twice in the initial setting mode.

The block at the top-left is selected and the current minimum management group number is displayed.

(2) The minimum management group number is incremented each time the  switch is pressed, and decremented each time the TEMP.  switch is pressed.

NOTE:

- The minimum management group number may be set between 1 and 50.
- When the minimum management group number is set to 20 or higher the group number for the block for the corresponding group will exceed 50. In this case indoor units cannot be registered in the block for which the group number is 51 or higher.

(3) After selecting the minimum management group number in (2) above, press the  switch twice to register the new minimum management group number.

NOTE: The minimum management group number setting is necessary when the system remote controller is set up as either a master or slave. (This is not necessary if the minimum management group number remains at the default value of 1 set before shipment.)



7-1-2. Group settings

Indoor units, ventilation units, slave system controllers, and local remote controllers are registered in each group.

(Register ventilation units as interlocked units in accordance with 7-1-3. Setting up interlocked units.)

- (1) Group selection
- (2) Unit selection
 - Registering a unit in a group
 - Deleting a unit from a group
 - Searching for a unit registered in a group

(1) Group selection

- ① The group selection display [▼] moves one position to the right each time the GROUP  switch is pressed. The group number is then incremented by one, and displayed for two seconds. (The opposite operation occurs when the  switch is pressed.)
- ② The registered minimum address number and the unit type are displayed when a further unit is registered in the selected group.

Example: Group 1 and 2 are not registered, and the indoor unit at address 005 is registered in group 3 (minimum management group number = 1).

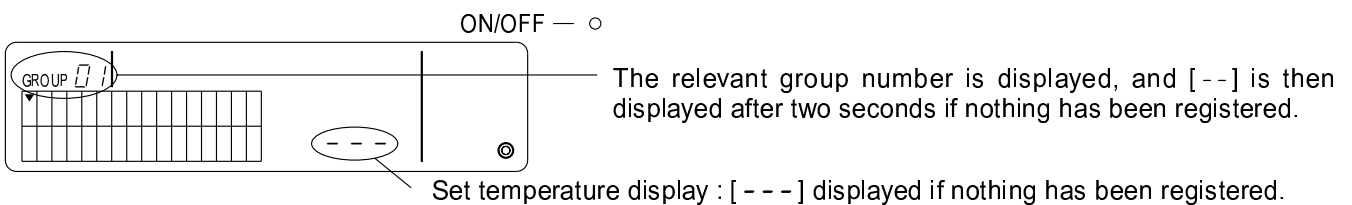

Initial setting mode

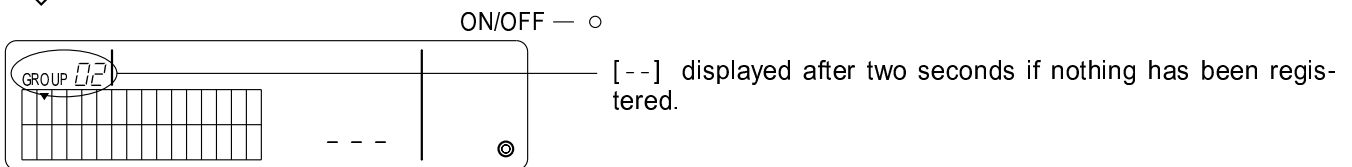

Select group 2

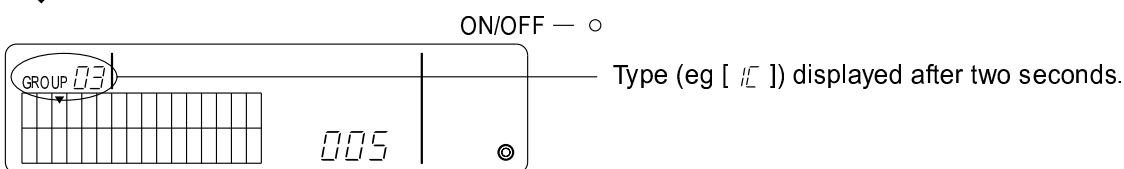

Select group 3

Indoor unit 005 now registered.

(2) Unit selection

- Registering a unit in a group

① The address is incremented each time the TEMP. (▲) switch is pressed, and decremented each time the (▼) switch is pressed. (The skip function operates if the switch is pressed for more than three seconds.)

NOTE: The setting ranges for addresses for the various types of registered units are as shown below.

Indoor units and ventilation units : 001 - 050
Local remote controllers : 101 - 200
Slave system controllers : 000, 201 - 250

* When a unit registered in another group is selected the group select display (▼) for the already registered group blinks.

② Press the (①) switch to register the selected unit in the group.

- The unit type is displayed when registration is completed normally.

Indoor units : IC Ventilation unit : LC
Local remote controller : RC System controller : SC

- [88] blinks if registration fails.

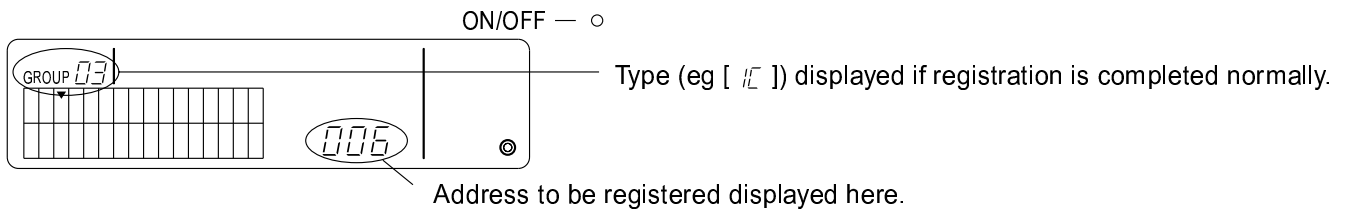

Registration complete screen



The indoor unit with address 006 is registered in group 3.

③ Repeat (2) above to register a different unit in the same group. To register in a different group, select the group and then repeat (1) and (2) above.

NOTE:

- Indoor units and ventilation units cannot be registered in the same group. If registration is attempted, [88] is displayed and registration does not proceed.
- When indoor units, ventilation units, and local remote controllers have already been registered in a different group, they cannot be registered in another group. (Slave system controllers may be registered in multiple groups.)

• Deleting a Unit from a Group

- ① Press the TEMP.  or  switch to select the unit to be deleted.
- ② Press the  switch twice to delete the selected unit from the group.

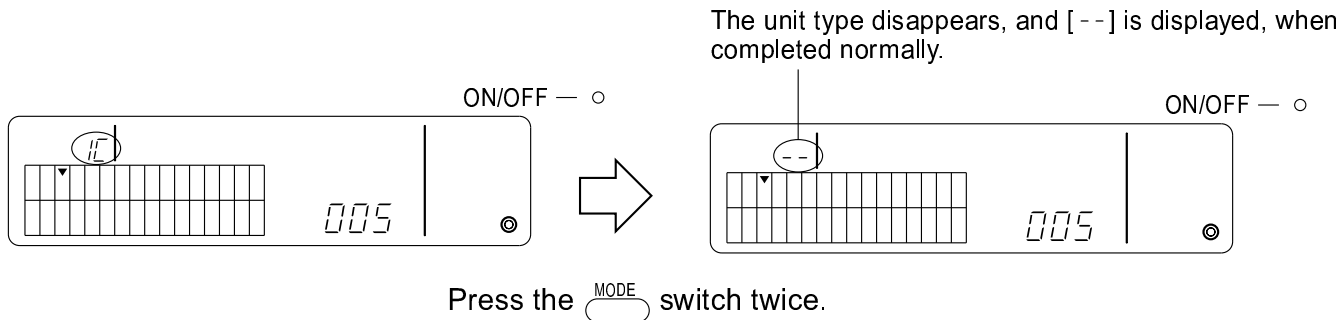

• Searching for a Unit Registered in a Group

- ① Select the group in which to search for the registered unit.
- ② The displayed registered unit address is decremented by one each time the  switch is pressed.

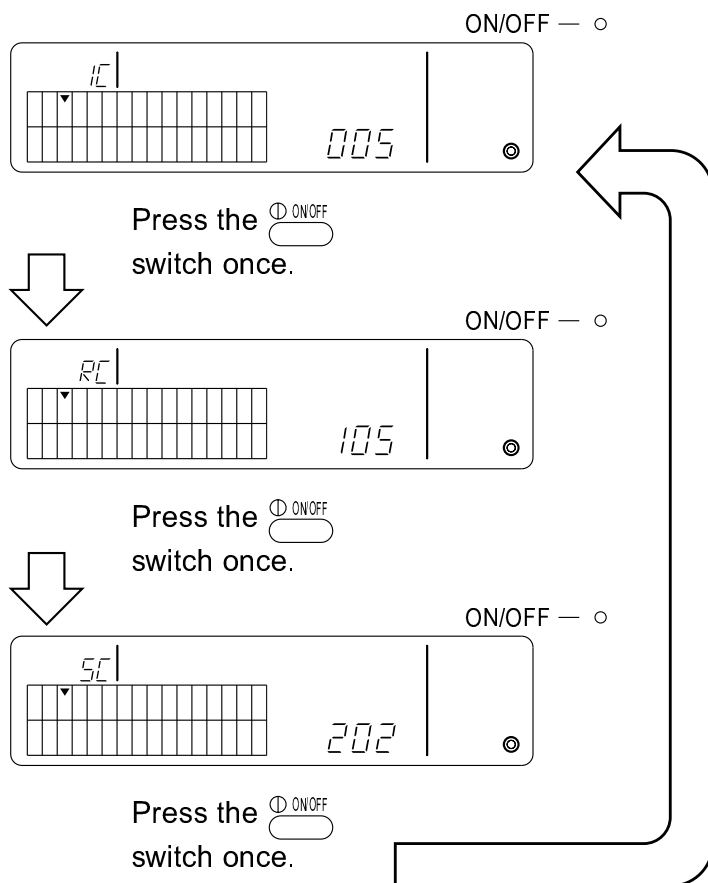

* When searching for the system controller (SC), the group select display (▼) also blinks if the controller is also registered in another group.

* [---] is displayed if nothing has been registered in the selected group.

7-1-3. Setting up interlocked units

Sets up interlocked operation of ventilation units in each group. Set up interlocked operation after setting up the group.

Interlocked units cannot be set up unless indoor units are registered in the desired group.

- (1) Call up the interlocked unit setting screen
- (2) Select the group
- (3) Select the master indoor unit
- (4) Select the interlocked unit address
 - Registering the interlocked unit
 - Clearing the interlocked unit
 - Confirming the interlocked unit

NOTE:

- When registering the interlocked unit, always link a interlocked unit to the indoor unit with the lowest address in the master group. If this is not done it will not be possible to operate the interlocked unit with the local remote controller.
- When a unit is to be interlocked to multiple indoor units, set up interlocked unit operation for all indoor units.

- (1) Call up the interlocked unit setting screen

Press the  switch to change from the initial setting screen to the interlocked unit setting screen.

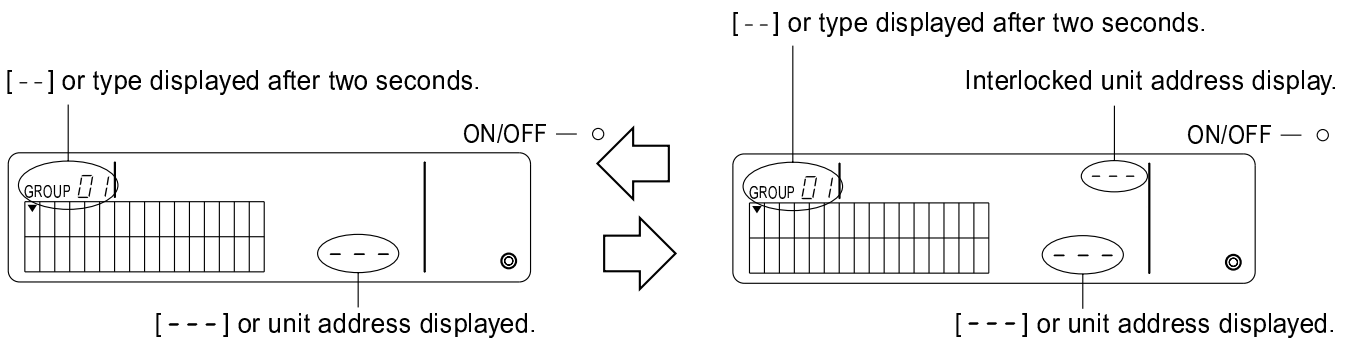



Initial setting screen
(initial setting mode screen)

Interlocked unit setting screen

The display toggles between the initial setting screen and the interlocked unit setting screen each time the  switch is pressed.

- (2) Select the group

Press the GROUP  or  switch to select the interlocked unit to be registered.

When the selected group contains and already registered unit, the registered indoor unit with the lowest address, and its unit type, are displayed.

Example: The indoor unit at address 003 is registered in group 2.

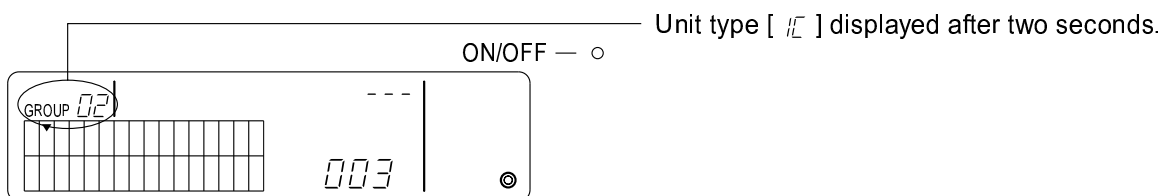

Interlocked unit setting screen (group 2)

(3) Select the master indoor unit

Press the COLLECTIVE ON/OFF switch to call up the address of the indoor unit to be set up as a interlocked unit.

(4) Select the interlocked unit address

The interlocked unit address is incremented each time the TEMP. ▲ switch is pressed, and decremented each time the ▼ switch is pressed.

NOTE: Addresses may be selected over a range of 001 - 050.

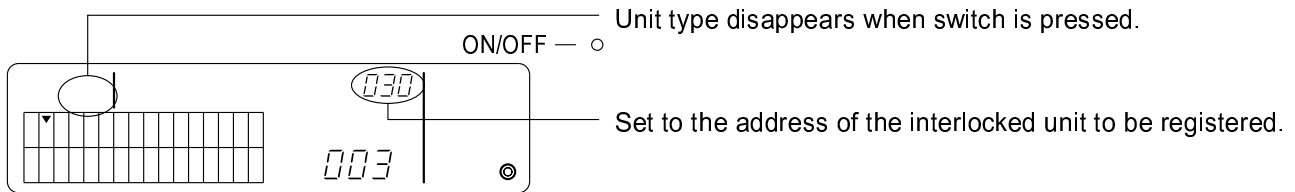

• Registering the interlocked unit

① Press the external timer switch to register the interlocked unit as interlocked to the displayed indoor unit.

The following is displayed if registration has proceeded normally. If not, [88] blinks in place of the unit type.

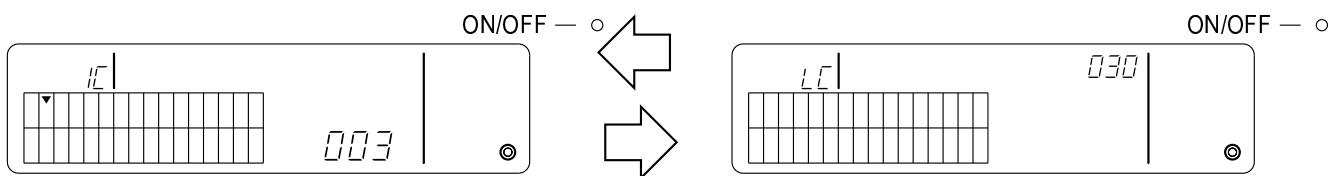

The address for the set indoor unit and the address of the interlocked unit, and the unit types, are displayed alternately.

② Setting up interlocked units



- To register a different indoor unit in the same group in the same interlocked unit, first select the indoor unit as described in (3), and then register it as a interlocked unit.
- To register an indoor unit in a different group in the same interlocked unit, first select the indoor unit in the different group as described in (2) and (3), and then register it as a interlocked unit.
- To register an indoor unit in a different group in a different interlocked unit, follow the steps from (2) and register it as a interlocked unit.

- Clearing the interlocked unit

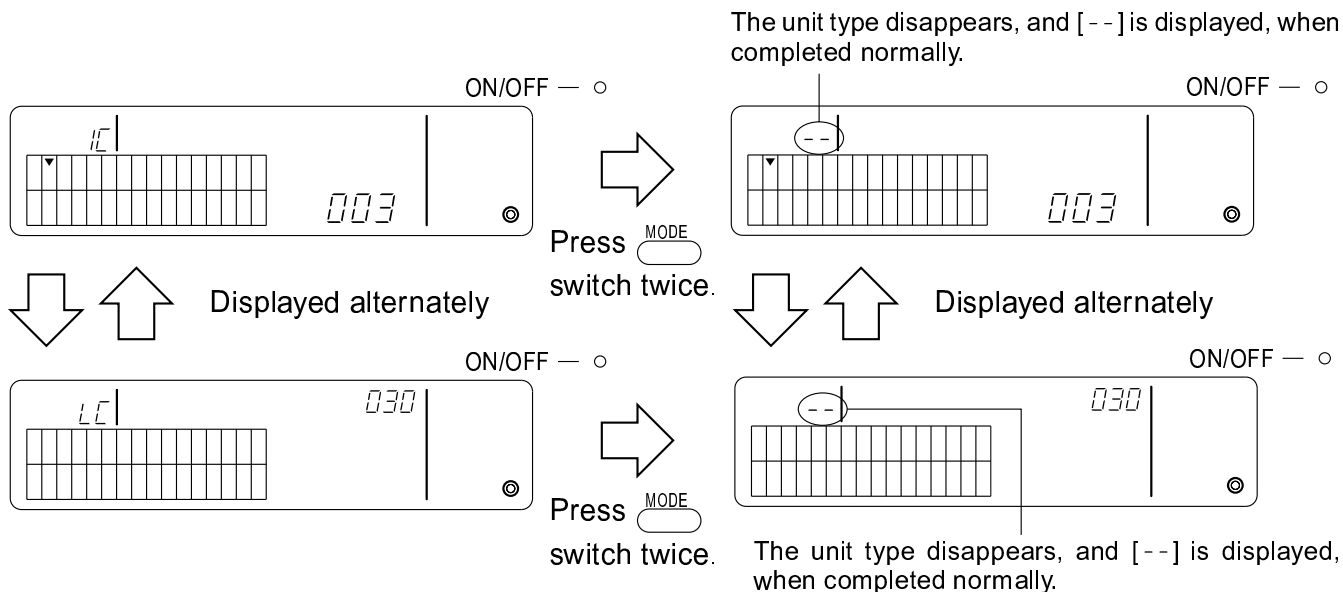
In the interlocked unit setting screen or the interlocked unit search screen, press the  switch twice to clear the interlocked setting.



- Confirming the interlocked unit

- ① Press the TEMP.  or  switch to select the address of the interlocked unit to be confirmed.
- ② Press the  switch to confirm the interlocked setting.

- With the interlocked setting
Repeat the following display.

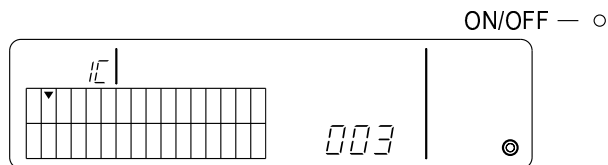

Displays the address and unit type of the indoor unit with the interlocked setting.

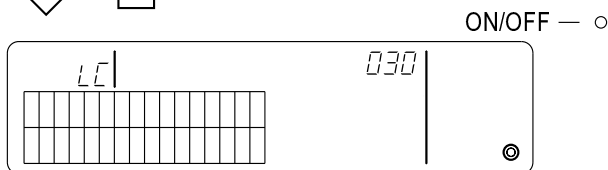
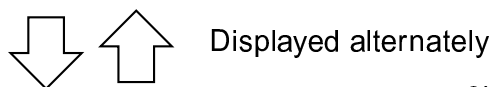

Displays the address and unit type of the interlocked unit.

In this condition, press the  switch to confirm the same interlocked unit and other indoor units with the interlocked setting.

- The following is displayed when not interlocked.

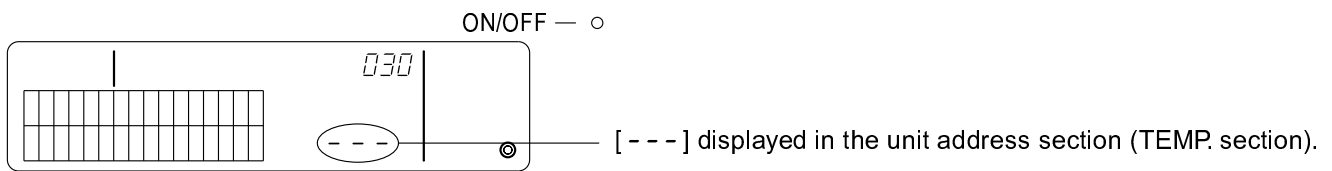

7-1-4. Collective deletion of registration details

Collective deletion of setting information for all groups and interlocked setting information.

- (1) Call up the initial setting screen or interlocked setting screen.
- (2) Press the **MODE** switch for more than three seconds to delete all the settings.

- NOTE:**
- Collective deletion is possible only when the system remote controller is set as a master system controller.
 - The minimum management group number is one following collective deletion.

Press the **MODE** switch for more than three seconds to delete all the settings.

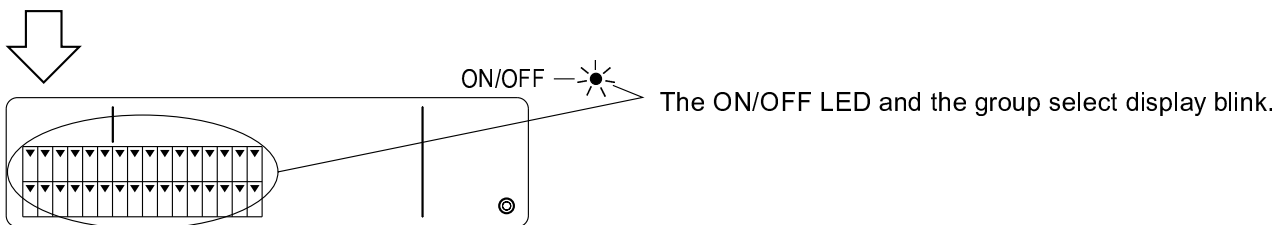

Communications processing associated with collective deletion.

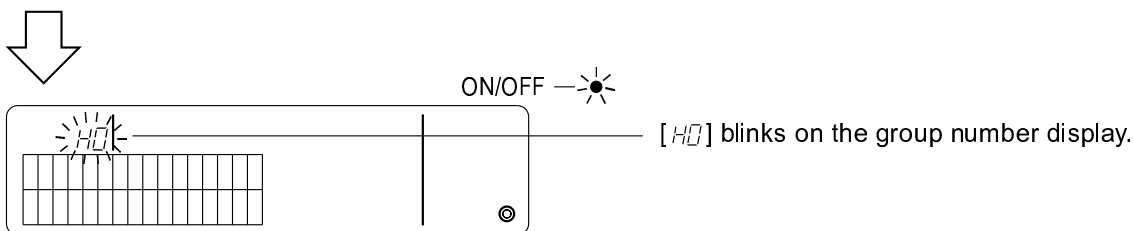

Initial status

7-2. When managed with the master system controller

The group and interlocked setting are not required with the system remote controller when the system remote controller is managed with another master system controller (i.e., when the system remote controller is a slave system controller).

Set the group and interlocked settings with the master system controller.

- NOTE:** The minimum management group number is always required, even when the system remote controller is set in the slave system controller.

7-3. Emergency stop mode setting

The following settings are required when emergency stop input is received at the external input pin of the system remote controller.

[Setting]

- Following system start-up communication, press the **COL./GROUP** and **ON/OFF** switches simultaneously for more than two seconds in the group operation screen or collective operation screen to display the following and enter the emergency stop mode.

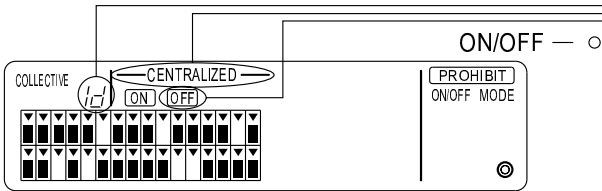

In addition to [—CENTRALIZED—] and [OFF], [L] blinks for two seconds in the group number display. Emergency stop input is then possible.

- When the **COL./GROUP** and **ON/OFF** switches are again pressed simultaneously for more than two seconds, the following is displayed, the emergency stop input mode is cleared, and the external timer mode is selected.

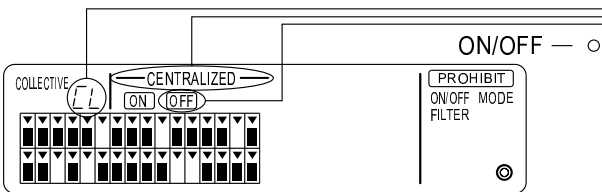

In addition to [—CENTRALIZED—] and [OFF], [L] blinks for two seconds in the group number display. The emergency stop input mode is then cleared and the external program timer may be connected.

NOTE: See the installation manual for the system remote controller for details of connecting the emergency stop input cable.

8. Specifications

Specifications for this equipment

Item	Details
Power supply	DC30 V (power supplied from the outdoor unit or a power unit for transmission lines (model: PAC-SC34KUA))
Electricity consumption	1 W
Environmental conditions for usage	Temperature 0 to 40 °C, humidity 30 to 90 % RH (with no condensation)
Weight	0.2 kg
External dimensions (H × W × D)	120 × 130 × 18 (mm)

