

APPLICABLE MODELS: PLHP..KAH, PCHP..GAH, PKHP..(F)(G)ALH  
 PLAP..KA, PCAP..GA, PKAP..(F)(G)AL

NOTE: THE VFC's ARE ONLY SUITABLE  
 FOR SWITCHING A LOW VOLTAGE  
 MAXIMUM SIGNAL:  
 40V DC or 24V AC 50 mA

EXTERNAL  
 PULSE ON/OFF (1 SEC)

"RUN" VOLT FREE CONTACTS  
 (CLOSED WHEN RUNNING)

"FAULT" VOLT FREE CONTACTS  
 (CLOSED WHEN IN FAULT)

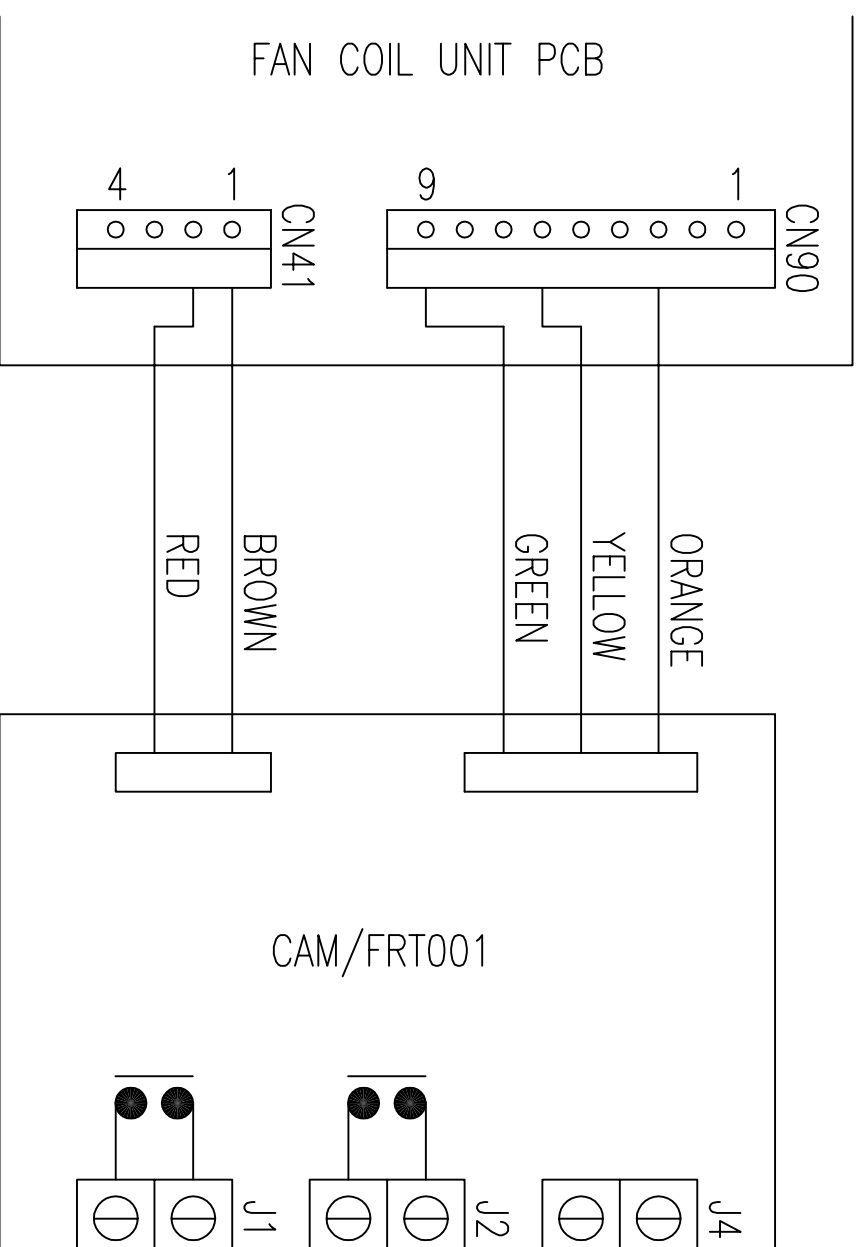

NOTE: (1) IF ON/OFF IS NOT REQUIRED, DO NOT CONNECT PLUG INTO CN41  
 (2) THE 'PKHP/PKAP' UNITS MUST HAVE THE OPTIONAL WIRED CONTROLLER  
 KIT INSTALLED (PART NO. PARS27AWTE)

TITLE		DRAWN BY
MITSUBISHI "P" SERIES, "A" CONTROL (R407C): CAM/FRT001 WIRING SCHEMATIC		
DRG NO. Procon FRT001 Schematic		DATE
		13/7/00