



M-NET Interface



Model **MAC-399IF-E**

[FOR INSTALLER]

**INSTALLATION MANUAL**

[FÜR INSTALLATEUR]

**INSTALLATIONSHANDBUCH**

[POUR L'INSTALLATEUR]

**MANUEL D'INSTALLATION**

[VOOR DE INSTALLATEUR]

**INSTALLATIEHANDLEIDING**

[PARA EL INSTALADOR]

**MANUAL DE INSTALACIÓN**

[PER L'INSTALLATORE]

**MANUALE DI INSTALLAZIONE**

[ΓΙΑ ΑΥΤΟΝ ΠΟΥ ΚΑΝΕΙ ΤΗΝ ΕΓΚΑΤΑΣΤΑΣΗ]

**ΕΓΧΕΙΡΙΔΙΟ ΟΔΗΓΙΩΝ ΕΓΚΑΤΑΣΤΑΣΗΣ**

[PARA O INSTALADOR]

**MANUAL DE INSTALAÇÃO**

[TIL INSTALLATØREN]

**INSTALLATIONSMANUAL**

[FÖR INSTALLATÖREN]

**INSTALLATIONSMANUAL**

[MONTÖR İÇİN]

**MONTAJ ELKİTABI**

[ДЛЯ УСТАНОВИТЕЛЯ]

**РУКОВОДСТВО ПО УСТАНОВКЕ**

[安装人员适用]

**安装说明书**

[安裝人員適用]

**安裝說明書**

English

Deutsch

Français

Nederlands

Español

Italiano

Ελληνικά

Português

Dansk

Svenska

Türkçe

Русский

简体中文

繁體中文

## About the M-NET Interface

The M-NET Interface is not compatible with all RACs.

Before installation, confirm that your RAC is compatible with this device.

## Contents

1. Safety Instructions .....	2
2. Before Installation .....	3
3. Mounting the M-NET Interface Unit .....	4
4. Setting the Switches .....	5
5. Connecting the M-NET Interface to an RAC .....	6
6. Connecting the M-NET Interface, the Power Supply, and the ME Remote Controller .....	7
7. Notes Regarding Use .....	8
8. Table of RAC Functions Activated from the ME Remote Controller/System Controller .....	9
9. Specifications .....	9

## 1. Safety Instructions

- Read all Safety Instructions before using this device.
- This manual contains important safety information. Be sure to comply with all instructions.
- After installing the Interface, provide this Installation Manual to the user.  
Instruct users to store their room air conditioner Instruction Manual and Warranty in a safe location.

### **Warning**

(Improper handling may have serious consequences, including injury or death.)

■ **Users should not install the Interface themselves.**

Improper installation may result in fire, electric shock, or damage/water leaks if the Interface unit falls. Consult the retailer or specialty store where you purchased the unit for referral to an installer.

■ **The Interface should be securely installed in accordance with the enclosed Installation Instructions.**

Improper installation may result in fire, electric shock, or damage/water leaks if the Interface unit falls.

■ **The unit should be mounted in a location that can support its weight.**

If installed in an area that cannot support the unit, the Interface unit could fall and cause damage.

■ **Securely attach the electrical component cover to the Interface unit.**

If the electrical component cover of the Interface unit is not securely attached, dust or water penetration could occur, resulting in a fire or electric shock.

■ **Mitsubishi components or other designated components should be used for installation.**

Improper installation may result in fire, electric shock, or damage/water leaks if the Interface unit falls.

■ **When performing electrical work, adhere to the Technical Standards Regarding Electrical Equipment and the Interior Wiring Standards, follow the instructions provided in the Instruction Manual, and be sure to use a dedicated circuit.**

Inadequate circuit capacity or improper installation could result in a fire or electric shock.

## 2. Before Installation

### 2.1. How to Use the M-NET Interface

#### ⚠ Caution

When using a system controller for a packaged air conditioner (PAC), you cannot register a packaged air conditioner (PAC) and a room air conditioner (RAC) in the same group. Be sure to register any RACs separately.

#### ■ Functions

Centralized and individual management of RACs (including housing air conditioners) using M-NET(\*).

\* A type of packaged air conditioner control

#### ■ Related Products Sold Separately

- ME Remote Controller PAR-F27MEA
- Centralized Controller G-50A
- System Remote Controller PAC-SF44SRA
- ON/OFF Remote Controller PAC-YT40ANRA
- Schedule Timer (M-NET) PAC-YT34STA
- Power supply unit PAC-SC50KUA

#### ■ Sample System Configuration

Sample configuration of a system using a centralized controller

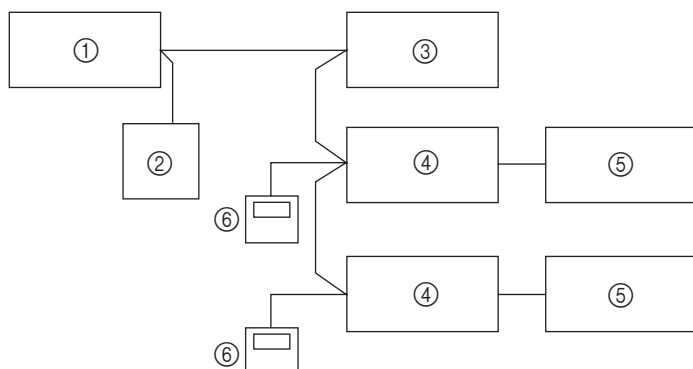

- ① Centralized controller
- ② Power supply unit
- ③ Packaged air conditioner system
- ④ M-NET Interface
- ⑤ RAC
- ⑥ ME Remote Controller

\* The number of units that can be connected to the centralized controller (G-50A) is max. 50, including packaged air conditioners and RACs. The wiring from the M-NET Interface to the centralized controller can have a maximum length of 500 m. The wiring from the M-NET Interface to the ME Remote Controller can have a maximum length of 10 m. For details, see the MELANS Catalog and the instruction manuals for the Centralized Controller and ME Remote Controller.

### 2.2. Accessory (check parts against the illustration provided)

Before installing the device, make sure you have all the necessary parts.

#### ■ Accessory

①	Interface unit	1
②	Mounting brackets	1
③	Screws (short) for mounting ② 3.5×12	4
④	Cushioning material	1
⑤	Cord clamp for mounting (small)	2
⑥	Mounting cord clamp (large)	2
⑦	Screws for mounting ⑤ and ⑥ 3.5×12	2
⑧	Screw for mounting ⑤ and ⑥ 4×10 * Use this when mounting cord clamp to and around RAC.	1
⑨	Screw for mounting ⑤ and ⑥ 4×16 * Use this when mounting cord clamp together with the parts of RAC.	1
⑩	Fasteners (for joining the lead wires)	5
⑪	Cord clamp for wiring	5
⑫	Screws (black) for mounting ⑪ 3.5×16	5
⑬	Interface case mounting screws (black) 3.5×12	2

#### ■ Items to Prepare at the Installation Site

A	Connection wiring (centralized controller) Shield wiring CVVS/CPEVS
B	Connection wiring (for connecting the ME Remote Controller) Remote control wires (2-core sheath wire 0.3 mm <sup>2</sup> )
C	Related parts sold separately * Prepare the necessary number of parts sold separately as needed for your system.

\* CPEVS; PE insulated PVC jacketed shielded communication cable

\* CVVS; PVC insulated PVC jacketed shielded control cable  
PE: Polyethylene PVC: Polyvinyl chloride

# 3. Mounting the M-NET Interface Unit

The M-NET Interface unit should be placed in a location where the connecting cable from the interface can reach an indoor unit. The device will not function properly if the connecting cable is extended so the connecting cable should not be extended. Mount the interface unit securely to a pillar or wall using 2 or more screws.

## ■ When Using Wall Mounting Brackets ②

**1** Attach the wall mounting brackets ② to the interface unit ① using 2 mounting screws ③.

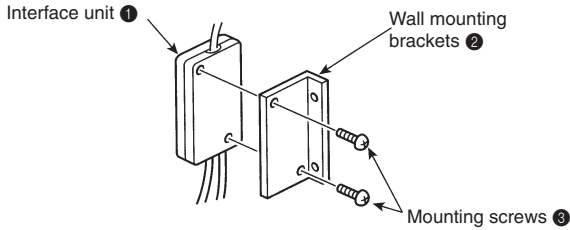

**2** Mount the unit to a pillar or wall using 2 mounting screws ③.

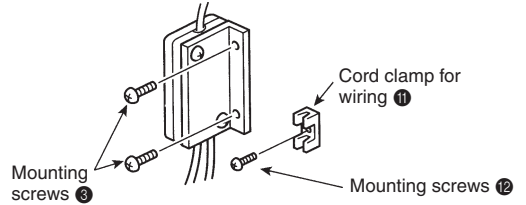

## ■ When Mounting Directly to a Wall

Mount the interface unit ① case to the wall using the mounting screws ③.

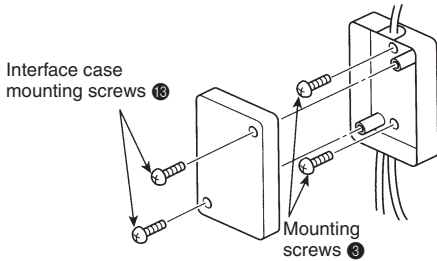

\* When mounting the interface unit ① using a cushioning material ④, be sure to mount it in a location where it will not fall.

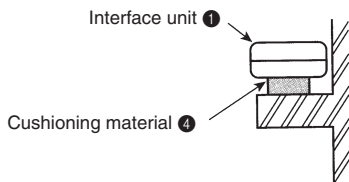

When mounting the interface unit ① inside a ceiling or wall, install an access door to facilitate maintenance.

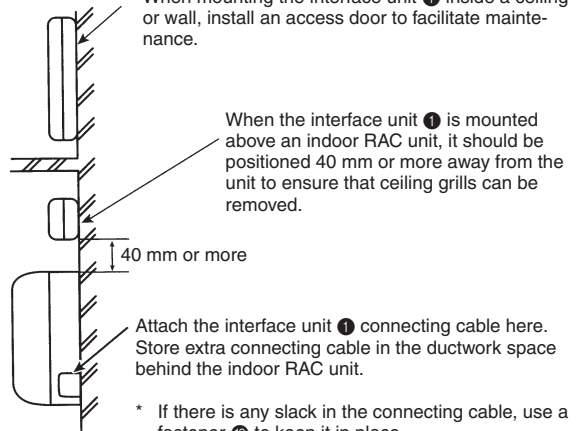

# 4. Setting the Switches

If the system is not configured correctly, the unit will not function properly. You may be unable to control the functions of the RAC from the System Controller/ME Remote Controller or functions not available on your RAC could appear on the System Controller/ME Remote Controller display. You should therefore ensure that the system is properly configured before connecting the power supply.

### ■ SW500 No. 1, No. 2 - Not in use

These should be set to OFF (if set to ON, the device will not communicate properly with the System Controller).

### ■ SW500 No. 3 - Power On/Off Settings

This setting indicates whether the RAC should be turned off or on when power is supplied to the RAC or M-NET Interface.

#### Turn on with power No

[Unit remains off when the power is supplied.]

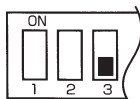

#### Turn on with power Yes

[Unit turns on when the power is supplied.]

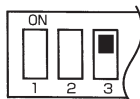

### ■ SW500 No. 4 - Availability of RAC purifier or fan mode

If there is no "Purifier" button on the wireless remote control, and if the word "Fan" does not appear when the "Mode" button is pressed, the purifier and fan modes are not available (set to OFF).

#### Does not have a purifier or fan mode

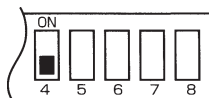

#### Has a purifier or fan mode

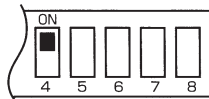

### ■ SW500 No. 5–No. 8 - RAC Function Check

SW500	Function description	How to check a function	OFF	ON
No. 5	Availability of automatic operation mode (a mode that allows the air conditioner to determine whether to select cooling or heating).	If "Auto" is not displayed when you push the "Mode" button on the wireless remote control, the auto operation mode is not available (OFF).	Does not have an auto operation mode	Does have an auto operation mode
No. 6	Availability of a fan oscillation setting	If "Oscillate" is displayed when you push the "Fan Direction" button on the wireless remote control, the fan oscillation setting is available (OFF). (If there is no "Fan Direction" button, the setting is OFF.)	Has a fan oscillation setting	Does not have a fan oscillation setting
No. 7	Availability of a fan direction setting	If there is a Fan Direction button on the wireless remote control, the fan direction setting is available (OFF).	Has a fan direction setting	Does not have a fan direction setting
No. 8	Availability of a heating mode	If "Heat" appears when you push the "Mode" button on the wireless remote control, the unit is a model that offers both cooling and heating (OFF).	Dual cooling and heating model	Cooling unit only

### ■ SW510, SW501 - Address settings

Specifies the address settings for centralized management (address settings can be set from 01–50).

#### Self-Address

10s position

1s position



SW510



SW501

SW510 sets the 10s position of the address and SW501 sets the 1s position of the address. For example, to set a unit to the address 25, set SW510 to "2" and SW501 to "5".

■ Position of SW500, SW501, SW510

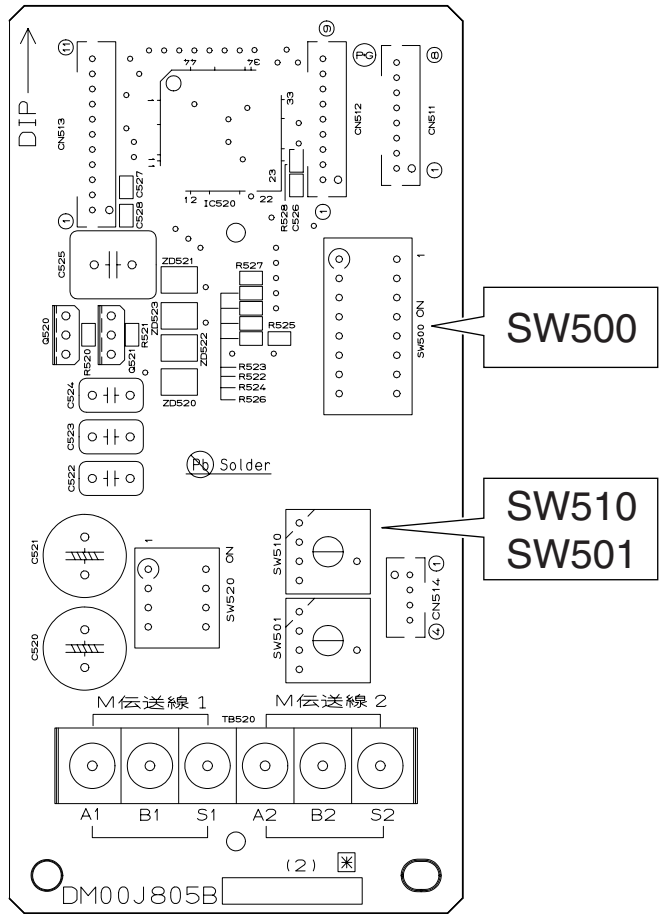
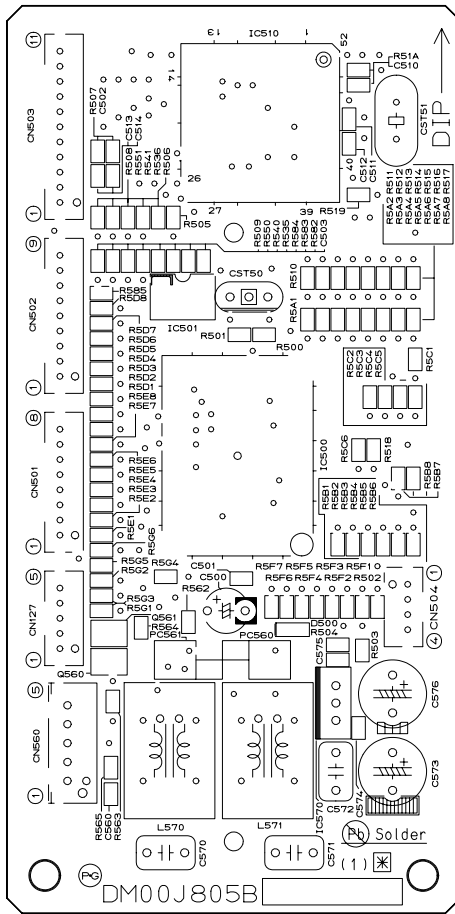

## 5. Connecting the M-NET Interface to an RAC

Connect the M-NET Interface board to the RAC indoor control board.

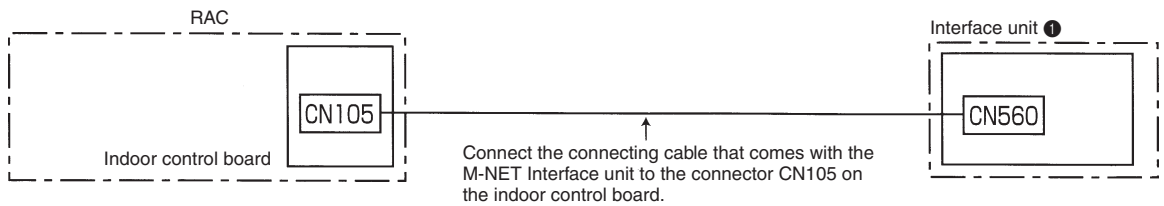

## 6. Connecting the M-NET Interface, the Power Supply, and the ME Remote Controller

- When connecting the unit to a system controller or ME Remote Controller, connect the transmission line of the M-NET to the control signal terminal.  
Connect the 2-core connection wirings **A** to A1/B1 or A2/B2 (they can be connected to either).
- Cross the shield portion of each connecting wire using the S terminal only when cross wiring the connection wires.
- When connecting the connection wirings **A** and the ME Remote Controller connection wirings **B** to the terminal board, there is no need to worry about polarity.

When the connection wirings **A** are not cross-wired

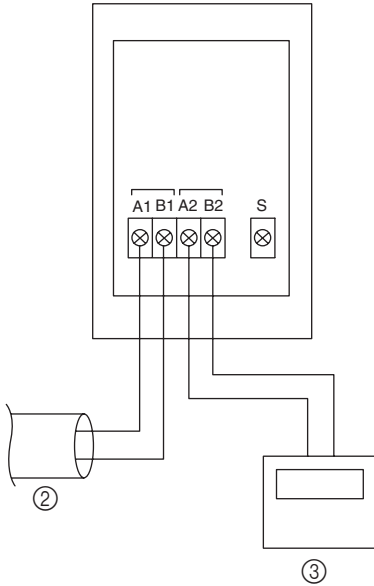

When the connection wirings **A** are cross-wired

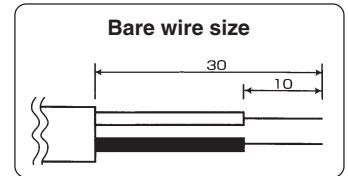
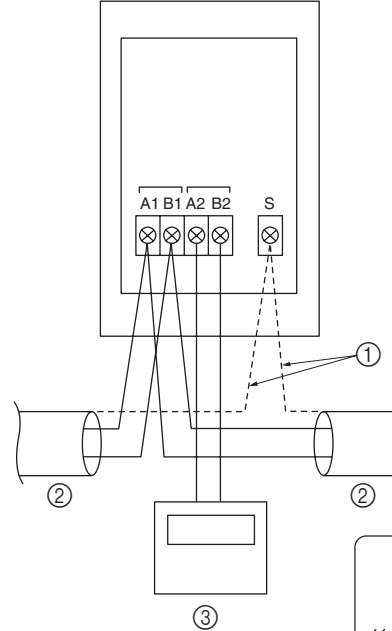

- After completing the wiring, securely affix a cord clamp to each electrical wire.

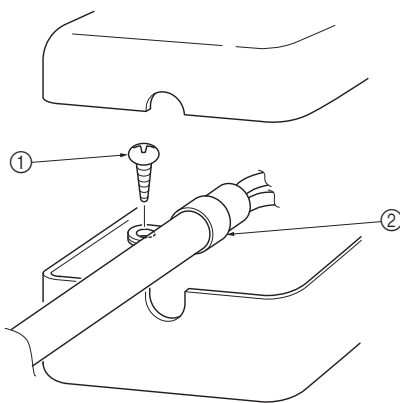

- Screws
- Cord clamp (large)
- Cut with nippers at the notches.

Make sure the cut surface is free of any burr so that the connection wire does not get damaged.

When the connection wirings **A** are cross-wired

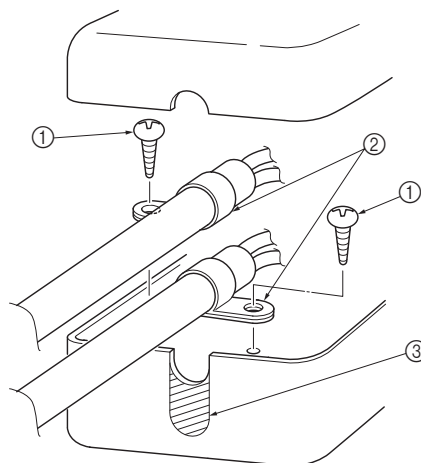

### ⚠ Caution

- Electrical work should be performed in accordance with the Technical Standards Regarding Electrical Equipment and the Interior Wiring Standards.
- Connection wiring and remote control wiring should be located as far away from other electrical wiring as possible. Placing them too closely together could cause a malfunction.

## 7. Notes Regarding Use

Please read this information carefully before attempting a test run.

The following control information should be thoroughly explained and provided to the users of this device. (Please provide these instructions to the user once the installation is complete.)

- \* This M-NET Interface operates RACs using the controls of a packaged air conditioner, but there are several limitations imposed as a result of the functional differences between RACs and packaged air conditioners.
  1. When operating the system using a system controller or ME Remote Controller, these operations will not appear on the display of the wireless remote controller.
  2. The dehumidifying modes (such as mold guards) of individual RACs cannot be operated using the ME Remote Controller/System Controller.

When an independent dehumidifying mode is set using the remote control that came with the RAC, "Dry" will appear on the display because there is no corresponding mode on the ME Remote Controller/System Controller.
  3. Functions that are available on the ME Remote Controller/System Controller but that are not available on the RAC can be operated by switching to a predetermined separate operation mode. (See the "Table of RAC Functions Activated from the ME Remote Controller/System Controller.")
  4. Functions that are available on the remote control of the RAC but are not available on the ME Remote Controller/System Controller will produce a predetermined display. In this case, the actual operation and the display may differ. (If the fan speed is automatically set using the remote control that came with the RAC, the setting "High" will appear on the ME Remote Controller/System Controller. Likewise, if the fan direction is set to automatic, the setting "Downward Air Flow 80%" will appear on the ME Remote Controller/System Controller.)
  5. Because the temperature range of the RAC is broader than the ME Remote Controller/System Controller, when the RAC is set to lower than 17°C or higher than 30°C, the temperature display on the ME Remote Controller/System Controller will show the minimum or maximum temperature that can be set. (For example, even if the room air conditioner is set to cool a room to 16°C, the display on the ME Remote Controller/System Controller may read "17°C.")

The RAC operates according to the room temperature detected by the RAC unit.
  6. Timer operations should be set using only the remote control that came with the RAC or the ME Remote Controller/System Controller. If both are used to set the timer to the same time, the timer will not function properly.
  7. When the timer is set using the remote control that came with the RAC, the timer information will not be displayed on the ME Remote Controller/System Controller.
  8. If the timer is set using the ME Remote Controller/System Controller, the timer set using that device will not be cancelled even if the unit is turned off using the remote control that came with the RAC.
  9. When manual operations using the system controller are prohibited, the remote control that came with the RAC will not function, but the beeping sound that is emitted when it is operating normally will still sound.
  10. To clear an error message from the display of the ME Remote Controller/System Controller, briefly turn off the unit using the ME Remote Controller/System Controller or the remote control that came with the RAC. (The error display on the air conditioner unit may be cleared automatically, but it will not clear from the ME Remote Controller/System Controller until the unit is turned off.)



## 8. Table of RAC Functions Activated from the ME Remote Controller/System Controller

This table shows the RAC functions that can be activated by the ME Remote Controller/System Controller.

	ME Remote Controller/System Controller operations/display	RAC response
Power	On/Off	On/Off
Mode	Fan	Fan
	Auto Cool	Cool
	Auto Heat	Heat
	Cool	Cool
	Heat	Heat
	Dry	Dry
Temperature settings	17–30°C	17–30°C
Fan speed settings	Low	Low
	Medium 1	Low
	Medium 2	Medium
	High	High
Air directional settings	Position 1 (Horiz.)	Position 1 (Horiz.)
	Position 2	Position 3
	Position 3	Position 4
	Position 4	Position 5
	Swing	Swing

\* Some items may not be displayed, depending on the switch settings.

\* When operating the unit using the remote control that came with the RAC, the operation shown on the remote is the one that will be activated on the actual RAC unit. In this case, the information shown on the display of the ME Remote Controller/System Controller may not accurately reflect the unit's actual operations (see the "Notes Regarding Use").

## 9. Specifications

Air conditioner side	Input voltage	12 V $\overline{\text{---}}$
	Power consumption	0.6 W
	Input current	0.05 A
M-NET side	Input voltage	17–24 V $\overline{\text{---}}$

This product is designed and intended for use in the residential,  
commercial and light-industrial environment.

The product at hand is based on the following EU regulations:

- Low Voltage Directive 73/23/EEC
- Electromagnetic Compatibility Directive 89/336/EEC

 **MITSUBISHI ELECTRIC CORPORATION**  
HEAD OFFICE: MITSUBISHI DENKI BLDG., 2-2-3, MARUNOUCHI, CHIYODA-KU, TOKYO 100-8310, JAPAN

---