

MITSUBISHI ELECTRIC

Building Air Conditioning Control System

System Remote Controller PAC-SF44SRA
Schedule Timer PAC-YT34STA
ON/OFF Remote Controller PAC-YT40ANRA

Installation Manual

This manual describes only the installation of the System Controller, capable of managing and controlling air conditioners, and LOSSNAY. Refer to the installation manuals enclosed with the air conditioner for details on wiring and installing the air conditioner unit. To ensure safety, always read (1) Safety Precautions below before starting installation.

1 Safety Precautions

The following two symbols are used to denote dangers that may be caused by incorrect use and their degree:

- WARNING** This symbol denotes what could lead to serious injury or death if you misuse above remote controllers.
 - CAUTION** This symbol denotes what could lead to a personal injury or damage to your property if you misuse above remote controllers.
- After reading this installation manual, keep it in a place where the final user can see it anytime he or she wants to it. When someone moves, repairs or uses above remote controllers, make sure that this manual is forwarded to the final user.

WARNING

- Ask your dealer or technical representative to install the unit.** Any deficiency caused by your own installation may result in an electric shock or fire.
- Install in a place which is strong enough to withstand the weight of above remote controllers.** Any lack of strength may cause above remote controllers to fall down, resulting in personal injury.
- Firmly connect the wiring using the specified cables. Carefully check that the cables do not exert any force on the terminals.** Improper wiring connections may produce heat and possibly a fire.
- Never modify or repair above remote controllers.** Any deficiency caused by your modification or repair may result in an electric shock or fire. Consult with your dealer about repairs.
- Ensure that installation work is done correctly following this installation manual.** Any deficiency caused by installation may result in an electric shock or fire.
- All electrical work must be performed by a licensed technician, according to local regulations and the instructions given in this manual.** Any lack of electric circuit or any deficiency caused by installation may result in an electric shock or fire.
- Do not move and re-install above remote controllers yourself.** Any deficiency caused by installation may result in an electric shock or fire. Ask your distributor or special vendor for moving and installation.

CAUTION

- Do not install in any place exposed to flammable gas leakage.** Flammable gases accumulated around the body of above remote controllers may cause an explosion.
- Do not use in any special environment.** Using in any place exposed to oil (including machine oil), steam and sulfuric gas may deteriorate the performance significantly or give damage to the component parts.
- When installing the remote controller in a hospital or communication facility, take ample countermeasures against noise.** Inverters, emergency power supply generators, high-frequency medical equipment, and wireless communication equipment can cause the remote controller to malfunction or to fail. Radiation from the remote controller may affect communication equipment and prevent medical operations on the human body or interfere with image transmission and cause noise.
- Wire so that it does not receive any tension.** Tension may cause wire breakage, heating or fire.
- Completely seal the wire lead-in port with putty.** Any dew, moisture, insects entering the unit may cause an electric shock or a malfunction.
- Do not wash with water.** Doing so may cause an electric shock or a malfunction.
- Do not install in any place at a temperature of more than 40°C or less than 0°C or exposed to direct sunlight.** Doing so may cause deformation or a malfunction.
- Do not install in any steamy place such a bathroom or kitchen.** Avoid any place where moisture is condensed into dew. Doing so may cause an electric shock or a malfunction.
- Do not install in any place where acidic or alkaline solution or special spray are often used.** Doing so may cause an electric shock or malfunction.
- Use standard wires in compliance with the current capacity.** A failure to this may result in an electric leakage, heating or fire.
- Do not touch any PCB (Printed Circuit Board) with your hands or with tools. Do not allow dust to collect on the PCB.** Doing so may cause fire or an electric shock.
- Do not remove the insulation sheet on the PCB.** Doing so may cause an electric shock.
- Do not touch any control button with your wet hands.** Doing so may cause an electric shock or a malfunction.
- Do not press any control button using a sharp object.** Doing so may cause an electric shock or a malfunction.
- Never apply 100VAC or 200VAC. The maximum voltage that can be applied on this unit is 30VDC.** Applying an excessive voltage may cause damage, igniting or fires.

(2) When connecting to indoor and outdoor transmission line

Up to three system controllers can be connected to the M-NET transmission line's indoor and outdoor transmission line. A power supply unit is not required in this case, but the short-circuit connector of one of the connected outdoor units must be connected to CN40.

NOTE: When the system remote controller is connected to the indoor and outdoor transmission line, the number of indoor units that can be connected in that refrigerant system will be reduced by two.

CAUTION

When connecting the system controller to the indoor and outdoor transmission line, operations from the system controller will be disabled if the outdoor unit's power is turned OFF, etc.

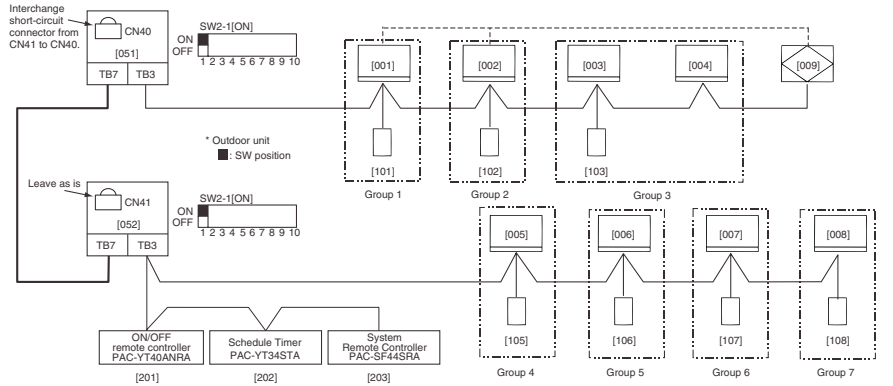

(3) Setting the various M-NET addresses

The need for address settings and the address setting range will differ according to the system configuration. (The address cannot be set in duplicate).

System controller	Address setting range	Setting method	Default address setting
ON/OFF remote controller	201 to 250	Set to the minimum group No. to be controlled + "200"	201
System remote controller	201 to 250	Random within address range shown on left	201
Schedule timer	201 to 250	Random within address range shown on left	202

(4) Setting the system controller address

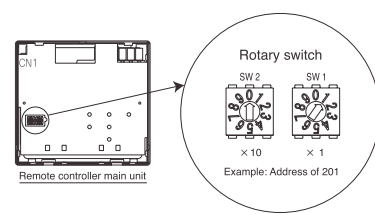

CAUTION When setting the address, prepare a precision screwdriver [(−), 2.0mm (w)], and keep the applied load to less than 19.6N. Setting with other methods could damage the rotary switch.

NOTE: The address No. that can be set on the remote controller is within the range of 201-250. The 100 digit is fixed at "2". If an address other than those listed above is set, an address setting error occurs and "AdE" is displayed.

(5) When using with master system controller

When connecting multiple system controllers, the system controller with many functions is designated as the "master", and the system controllers with few functions are designated as the "slaves". The "master/slave" functions of the system controller used together are as follows.

The functions have a priority in order of G50A (MJ-103MTRA) > PAC-SF44SRA > PAC-YT34STA > PAC-YT40ANRA > PAC-SC30GRA > LMMP02-E.

	System remote controller (44SRA)/Schedule timer (34STA)	ON/OFF remote controller (40ANRA)
Master side	SW3-1: OFF	SW4-1: OFF
Slave side	SW3-1: ON	SW4-1: ON

* The switch is set to "Master" as the factory setting.

2 Confirming the Supplied Parts

Confirm that the box includes the following parts, in addition to this installation manual:

- (1) Remote controller (Body, lower case) 1
- (2) Cable for external input (5 wire) 1
- (3) Cable for external output (4 wire) 1
- (4) Cross recessed pan head screw (M4 x 30) 2
- (5) Wood screw (4.1 x 16, used for directly hooking to the wall) 2
- (6) Room name label or room name record sheet 1
- (7) Operation Manual 1

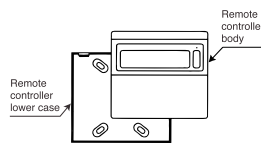

NOTE: The remote control cord is not supplied with the product. Prepare electrical wiring that conforms to the specifications given below.

Electrical wiring specification (CVVS)

- Use 1.25mm² cable for any extension that exceeds 10m. Remote controller wiring entry points can support electrical wiring of maximum 1.25mm².
- 10m or shorter : 0.75mm² two-wire cable
- Longer than 10m : 1.25mm² two-wire cable
- However 0.75mm² electrical wiring is recommended for use.

3 System Configurations

(Refer to the "System Design and Work Manual" for the outdoor unit for details.)

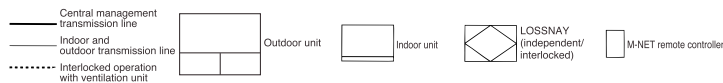

(1) When connecting to a central management transmission line

A power supply unit (PAC-SC34KUA) is required.

Power supply unit	Number of connected system controllers	
	ON/OFF remote controller	System remote controller schedule timer group remote controller
PAC-SC34KUA	1 to 5 units	1 to 10 units

* The power consumption of the system controller, schedule timer and group remote controller is half of the ON/OFF remote controller. Thus, interpret the power consumption per unit as half of the ON/OFF remote controller.

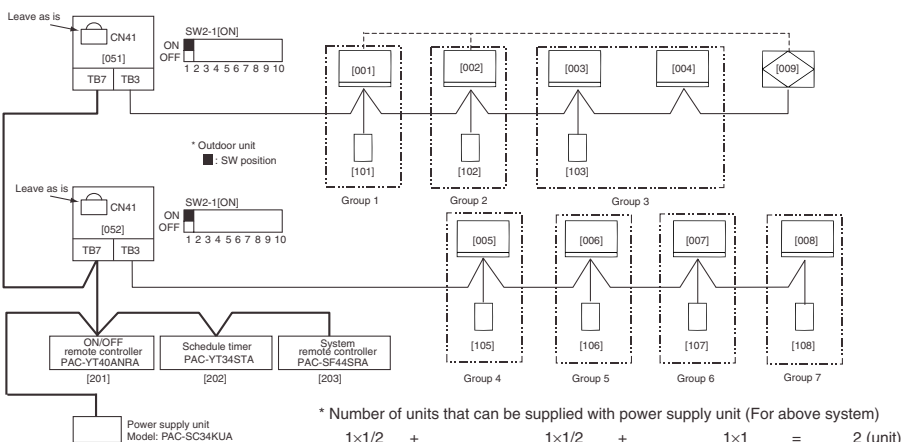

* Number of units that can be supplied with power supply unit (For above system)

1x1/2 + 1x1/2 + 1x1 = 2 (unit)

One system remote controller One schedule timer One ON/OFF remote controller

4 Using the External Input and Output

When using the external input and output functions, use the external input and output cables provided with the remote controller. (5 wire cable for input and 4 wire cable for output are provided.)

1. External signal input function

Emergency stop/Normal, ON/OFF and Prohibit/Permit local remote controller operation control can be applied to all units being controlled by inputting the no-voltage contact signal from an external source.

No.	External input signal functions	System remote controller SW3		Schedule timer SW3		ON/OFF remote controller SW4		Input state
		2	3	2	3	2	3	
1	Do not use external input	OFF	OFF	OFF	OFF	OFF	OFF	—
2	Change between Emergency stop/Normal. All units will stop with the external input, and all operations of this unit, other system controllers and local remote controller will be prohibited.	OFF	ON	OFF	ON	OFF	ON	Level input
3	Set ON/OFF. All units will turn ON/OFF according to the input state. ON/OFF operations using this unit and the local remote controller will be prohibited when using this function.	ON	OFF	ON	OFF	ON	OFF	Level input
4	Set ON/OFF and Prohibit/Permit. All units are started or stopped, or all local remote controller operations are prohibited according to the input state. When prohibit is input, the local remote controller's ON/OFF, operation mode, set temperature and filter reset operations will be prohibited. Operation with this system will be enabled.	ON	ON	ON	ON	ON	ON	Pulse input (0.5sec or more)

NOTE: For System remote controller and Schedule timer
 * If the SW3-4 "operation prohibit setting changeover" is set to "OFF (disable)", use is possible only for emergency stop.
 * If the SW3-5 "operation prohibit range setting changeover" is set to "ON (including system controller)", operations of the local remote controller and other system controllers will be prohibited by the prohibit input. If set to "OFF (only local remote controller)", operation of only the local remote controller will be prohibited. (When the level "emergency stop" or "ON/OFF" is input, operation of the other system controllers will also be prohibited regardless of the switch setting.)
 For ON/OFF remote controller
 * All units are stopped when emergency stop is input, and ON/OFF operations of this unit, other system controllers and local remote controller will be prohibited.
 * Only ON/OFF of the local remote controller will be prohibited with the prohibit input.

(2) Level signal and pulse signal

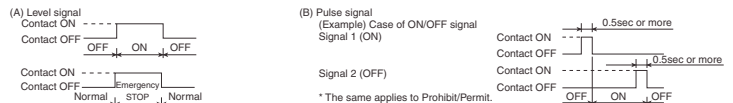

(3) External input specification

CN2	Lead wires (5 wires)	Level signal for Emergency stop/Normal	Level signal for ON/OFF	Pulse signal for ON/OFF, Prohibit/Permit
No. 1	Green	Emergency stop/Normal input	ON/OFF input	On input
No. 2	Yellow	Not used	Not used	Off input
No. 3	Orange	Not used	Not used	Prohibit local remote controller operation input
No. 4	Red	Not used	Not used	Permit local remote controller operation input
No. 5	Brown	Common OV		

(4) Example of a recommended circuit

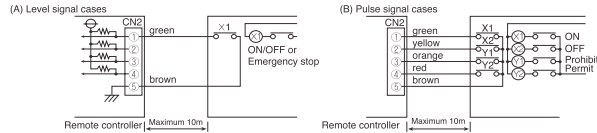

- The relays and extension cables, etc. must be prepared separately at the site.
- Use a no-voltage contact and minute load relay (minimum application load 5VDC-1mA).
- The length of the connection cable extension should not exceed 10m. (Use a cable of 0.3mm² or thicker.)
- Cut of the cable not being used close the connector and properly insulate the cut off ends with tape or the like.

NOTE: For level signal

Contact operation	External input		Operation state	
	Emergency stop/Normal	Normal -Emergency stop	ON/OFF	OFF - ON
OFF - ON	Emergency stop -Normal	OFF - ON	ON - OFF	
ON - OFF	Emergency stop -Normal	ON - OFF		

For pulse signal

- Operation will continue even if a ON signal is input during operation. (This also applies to OFF, prohibit and enable).
- If the local remote controller is prohibited, ON/OFF, operation mode, temperature and filter reset operations using the local remote controller will be prohibited. (Only ON/OFF are prohibited for the ON/OFF remote controller.)
- Set the pulse duration (contact ON time) to 0.5sec or more.

2. External signal output function

(1) External output

In the case when one or more air conditioner units are "ON", and an error is occurring on one or more air conditioner units, a signal indicating that an error is occurring is output.

(2) External output specification

CN3	Lead wires (4 wires, with black tube)	Detail of each terminal
No. 1	Yellow	ON/OFF
No. 2	Orange	
No. 3	Red	Error/Normal
No. 4	Brown	

* "On" is output even when there is "Error".

(3) Example of a recommended circuit

In the case of a relay being operated

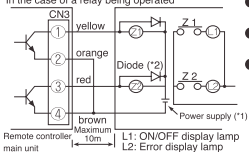

- When units are "ON" and an error is occurring, each element is ON.
- The extension length of the connection cable can be up to 10 m.
- The relay, lamps, diodes and extension cables are not supplied with the product.

For relay Z1, Z2 use the specifications given below.
 Operation coil
 Rated voltage: 12VDC, 24VDC
 Power consumption: 0.9 W or less
 (*1) Provide a power supply suitable to the relay used. (12VDC or 24VDC)
 (*2) Always insert diodes at both terminals of the relay coil.

5 Setting the functions

(1) Setting local remote controller operation prohibit function from this controller (excluding ON/OFF remote controller)

When connecting several system controllers, and setting the "local remote controller operation prohibit" function from this controller, set this controller's SW3-4 "operation prohibit setting changeover" to "ON (permit)".

(2) Changing set temperature display to "Fahrenheit display" (excluding ON/OFF remote controller)

To prohibit the operation of a system controller other than this system when local remote controller operation prohibit is set from this system, set SW3-5 "operation prohibit range setting changeover" to "ON (including system controller)".

[System remote controller (SF44SRA)
/Schedule timer (YT34STA)]

[ON/OFF remote controller (YT40ANRA)]

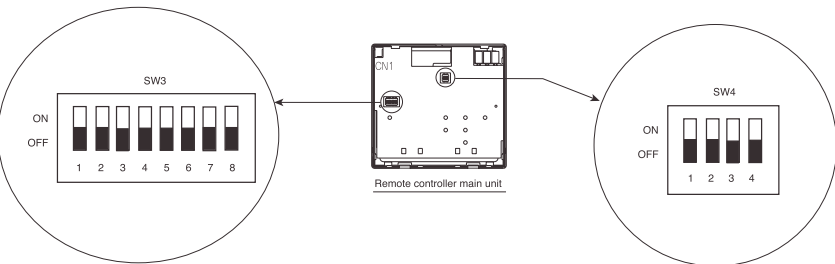

NOTE : There are other function setting items depending on the device.
 For details on setting the functions and the operation methods, refer to (3) List of switch settings and each respective instruction manual before turning the power ON.

6 How To Install

(1) Choose a location in which to install the system remote controller (electric box) in accordance with the following requirements:

- The space as shown in the diagram at right is required whether the controller is installed on the wall or in the electric box.
- Procure the following parts locally.
 - Electric box for two units
 - Thin-copper wiring pipe
 - Locknut and bushing

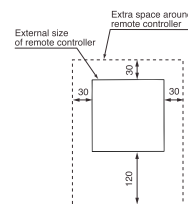

(2) Seal the remote controller cord lead-in with putty in order to prevent the possible entry of dew, water droplets, other insects.

When using the electric box

- When fitting to the electric box, seal the joint between the electric box and the wiring conduit with putty.

When fitting directly on the wall

- When cutting a hole in the wall for the remote controller cord (when the remote controller cord exits from the rear of the remote controller), seal this hole in the same way.
- When fitting directly to the wall as in 3, seal the cut-out in the upper case with putty.

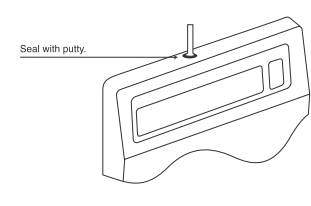
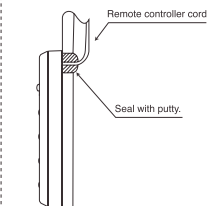
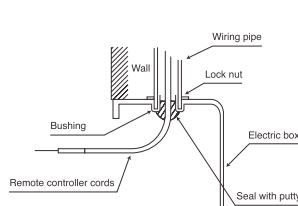

(3) Install the lower case on the electric box or directly on the wall.

When using the electric box

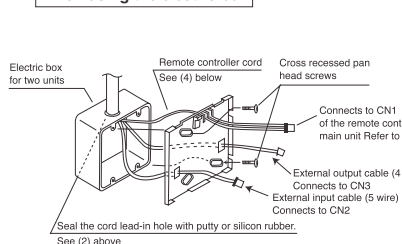

When installing directly on the wall

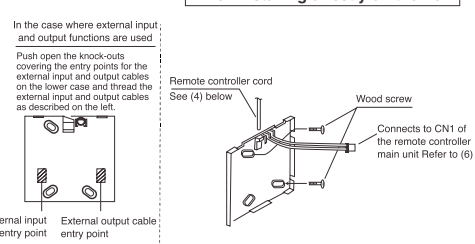

CAUTION Over-tightening the screws may result in deformation or cracking of the lower case.

NOTE : - Choose a flat plane for installation.
 - Fasten the electric box at more than two places when installing directly on the wall.

5

7

(3) List of switch settings

System remote controller (SF44SRA)

Name	Switch NO.	Function	Setting method	Default setting
System controller master/slave setting changeover	SW3-1	OFF Master SC setting	To set system controller as master	OFF
		ON Slave SC setting	To set system controller as slave	
External input function changeover	SW3-2, 3	No. 1 OFF OFF Do not use external inputs	Input state	OFF
		2 OFF ON Change between emergency stop/normal	Level input	
		3 ON OFF Set ON/OFF	Level input	
		4 ON ON Set ON/OFF, prohibit/enable	Pulse input (0.5sec or more)	
Operation prohibit setting changeover	SW3-4	OFF Set the local remote controller operation prohibit functions	To not use this system's operation prohibit function	OFF
		ON Operation prohibit enable	To use this system's operation prohibit function	
Operation prohibit range setting changeover * Valid only when SW3-4 is ON	SW3-5	OFF Only local remote controller	To prohibit operation of only the local remote controller	OFF
		ON Including system controller	To prohibit operation of the local remote controller and other system controllers	
Not used	SW3-7			OFF
Not used	SW3-8			OFF

Schedule timer (YT34STA)

Name	Switch NO.	Function	Setting method	Default setting
System controller master/slave setting changeover	SW3-1	OFF Master SC setting	To set system controller as master	OFF
		ON Slave SC setting	To set system controller as slave	
External input function changeover	SW3-2, 3	No. 1 OFF OFF Do not use external inputs	Input state	OFF
		2 OFF ON Change between Emergency stop/Normal	Level input	
		3 ON OFF Set ON/OFF	Level input	
		4 ON ON Set ON/OFF, prohibit/permit	Pulse input (0.5sec or more)	
Operation prohibit setting changeover	SW3-4	OFF Set the local remote controller operation prohibit functions	To not use this system's operation prohibit function	OFF
		ON Operation prohibit enable	To use this system's operation prohibit function	
Operation prohibit range setting changeover * Valid only when SW3-4 is ON	SW3-5	OFF Only local remote controller	To prohibit operation of only the local remote controller	OFF
		ON Including system controller	To prohibit operation of the local remote controller and other system controllers	
Set temperature display changeover	SW3-6	OFF Celsius display	To display set temperature as Celsius (°C)	OFF
		ON Fahrenheit display	To display set temperature as Fahrenheit (°F)	
Not used	SW3-7			OFF
Not used	SW3-8			OFF

ON/OFF remote controller (YT40ANRA)

Name	Switch NO.	Function	Setting method	Default setting
System controller master/slave setting changeover	SW4-1	OFF Master SC setting	To set system controller as master	OFF
		ON Slave SC setting	To set system controller as slave	
External input function changeover	SW4-2, 3	No. 1 OFF OFF Do not use external inputs	Input state	OFF
		2 OFF ON Change between Emergency stop/Normal	Level input	
		3 ON OFF Set ON/OFF	Level input	
		4 ON ON Set ON/OFF, prohibit/permit	Pulse input (0.5sec or more)	

(4) Connect the remote controller cord to the terminal block on the lower case.

Install wiring correctly in accordance with the diagram below.

No polarity

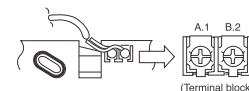

Remote controller cord procured locally.

CAUTION Do not use crimp terminals to connect to remote controller terminal blocks. It connects to the circuit board and will cause trouble.

(5) Wiring hole for fitting directly on the wall (For exposed wiring)

Remote Controller cord

- Cut off the shaded area from the upper cover using a knife, nippers, etc.
- Take out the remote control cord connected to the terminal block via this portion.

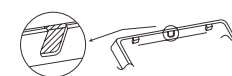

External input/output cables (Only in the case when using external input and output functions directly connected to the wall)

- Using a suitable knife or cutting implement, cut and remove the thin walled part on the left and right side of the remote controller main unit.
- CN2 side: For external input cable CN3 side: For external output cable
- Insert the external input/output cables through these points.

(6) Connect the lower case connector to connector CN1 on the upper case.

When using the external input and output function, also connect the external input cable connector (5 wire) to CN2 and connect the external output cable connector (4 wire) to CN3.

CAUTION After connecting, do not suspend the case as shown on the right. Doing so could result in cord breakage or malfunctions, etc.
 Always pass the cord through the hook (cord fixing). If not passed through, force will be directly applied on the terminal block and could break the cord.
 Do not remove the PCB protection sheet or PCB. Doing so could lead to faults.

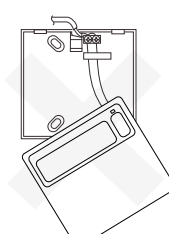
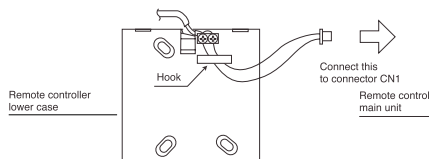

(7) Mount the remote controller main unit.

The first, hook the two upper claws and then fit it as shown in the diagram at right.

When the external input and output functions are used and the lower case cable entry points are being used, mount the remote controller main unit while pushing the external input/output cables to the electric box side.
 (Push towards the electric box sides from the lower case until the cable sheath part is reached.)

CAUTION Press the cover until it snaps shut. If not, it may fall off.

NOTE : A protective sheet has been affixed to the control panel.
 Remove it before starting.

To remove the remote controller body, insert a minus screwdriver into one of the open slots and move it in the direction of the arrow as shown in the diagram at right.

CAUTION Do not turn the screwdriver in the slot.
 Doing so may damage the slot.

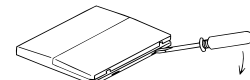

7 Initial Settings

Initial settings is necessary before test run. Consult the Instruction Book for details of initial settings.

8 Test Run

Please perform a test run of each air conditioning unit with the local remote controller.

6

8