

MITSUBISHI ELECTRIC CORPORATION

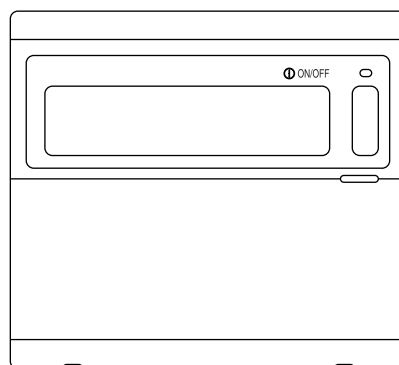

Mitsubishi Electric Building Air Conditioning Control System

System remote controller **Type** PAC-YT34STA



INSTRUCTION BOOK

Carefully read this book before use. It is recommended to safe keep this book for future reference.

ANWEISUNGSHANDBUCH

Vor Benutzung der Anlage dieses Buch sorgfältig durchlesen. Es wird empfohlen, dieses Buch zum Nachschlagen an einem sicheren Ort aufzubewahren.

MANUEL D'UTILISATION

Lire attentivement le présent manuel avant toute utilisation et le conserver dans un endroit sûr pour pouvoir le consulter ultérieurement.

LIBRO DE INSTRUCCIONES

Lea cuidadosamente este libro antes de usar el temporizador. Le recomendamos que guarde el libro en lugar seguro en previsión de consultas Futuras.

LIBRETTO ISTRUZIONI

Leggere attentamente questo libretto prima dell'uso. Si raccomanda di tenerlo in un luogo sicuro per ogni futura necessità.

INSTRUCTIEHANDLEIDING

Lees deze handleiding aandachtig door voordat u het apparaat in gebruik neemt. Het wordt aangeraden om deze handleiding zorgvuldig te bewaren om later, indien nodig, te raadplegen.



CONTENTS

Page

1.	Safety Precautions	2
2.	Names and functions of each part	4
2-1.	Appearance	4
2-2.	Display sections	5
2-3.	Operation section	6
2-4.	Screen configuration	7
3.	Outline of schedule setting and operation	8
3-1.	Outline of setting	8
3-2.	Schedule operation	9
4.	Operation methods	10
4-1.	Normal screen (COLLECTIVE/GROUP STATUS DISPLAY SCREEN)	10
4-1-1.	Group selection operation	10
4-1-2.	ON/OFF operations	11
4-1-3.	Stopping the schedule operation collectively for all groups	11
4-1-4.	Display	11
4-2.	PROGRAM MONITOR screen	11
4-3.	TIME/DAY SETTING screen	12
4-4.	PROGRAM SETTING screen	12
4-4-1.	Setting the program	13
4-4-2.	Setting the operation details	13
4-4-3.	Deleting an operation setting	14
4-4-4.	Copying the details of a pattern setting	14
4-5.	WEEKLY PROGRAM SETTING screen	14
4-5-1.	Setting the operation pattern	15
5.	Troubleshooting	16
5-1.	When "COLLECTIVE ON/OFF LAMP" and "ERROR CODE" are flickering	16
5-2.	When only the "Error Code" is flickering	16
6.	External input and output functions	17
6-1.	External input	17
6-1-1.	Emergency stop input mode	17
6-1-2.	ON/OFF level signal input mode	17
6-1-3.	ON/OFF, operation prohibit/permit pulse input mode	18
6-2.	External output	18
7.	Initial settings	19
7-1.	When this controller is master system	19
7-1-1.	Setting the group	21
7-1-2.	Setting the interlocked units	24
7-1-3.	Collective deletion	28
8.	Setting the functions	28
8-1.	Using with master system controller	28
8-2.	Using the external input/output function	29
8-3.	Disabling the local remote control's operations from this controller	29
8-4.	When local remote controller and system controller are prohibited	29
8-5.	Changing set temperature display to "Fahrenheit display"	29
9.	System limits	30
10.	Specifications	31
10-1.	Product functions	31
10-2.	Main specifications	32

1. Safety Precautions

■ Always read these "Safety Precautions" before starting, and perform the installation work correctly.

■ The dangers and degree that could occur if handling is mistaken are ranked with the following symbols.

⚠WARNING	When fatalities or serious injuries could result if handling is mistaken.
⚠CAUTION	When personal injury, or damage to house or assets could result if handling is mistaken.

■ After reading this manual store it in a safe place together with the installation manual for future reference.

When changing users, always give this manual and the installation manual to the new user.

⚠WARNING

- Unit must not be installed by user.
Always contact your dealer or a specialist to install the unit. Improper installation by the user could result in electric shocks or fires, etc.
- Check the installation state.
Always check that the unit is installed on a solid place where it will not fall off.
- Check the rated power supply.
An incorrect power supply could result in fires or unit trouble.
- Stop immediately when error occurs.
Continuing operation in an erroneous state could result in trouble, electric shocks or fires, etc. If any abnormality is sensed (burning smell, etc.), always stop the operation, turn the power switch OFF, and contact your dealer.
- Unit must not be moved and re-installed by user.
Improper installation by the user could result in electric shocks or fires, etc.
Always contact your dealer or a specialist when the unit must be moved.
- Unit must not be disposed by user.
Contact your dealer when the unit must be disposed of.
- Never modify or repair the unit.
Improper modifications or repairs could result in electric shocks or fires, etc. Always consult your dealer for repairs.
- Stop operation if operation is inhibited with an error display or if a fault occurs.
Continuing operation could result in fires or faults.
Contact your dealer.

⚠CAUTION

- Do not place hazardous objects near unit.
Do not install this unit where flammable gases could leak. If flammable gases leak and accumulate around the unit, fires or explosions could result.
- Do not wash this unit with water.
Washing the unit with water could result in electric shocks or faults.
- Do not operate switches with wet hands.
Touching the controller with wet hands could result in electric shocks or faults.
- Do not use for special applications.
This product is intended for use with the Mitsubishi Electric building air conditioning control system. Do not use for the control of other air conditioners or for other applications.
Failure to observe this could result in malfunctioning.
- Do not spray insecticide or flammable sprays onto unit.
Do not place flammable sprays, etc., near the unit or spray these directly onto the unit.
Doing so could result in fires or explosions.
- Do not use in special environments.
Using this product in environments containing a high level of oil (including machine oil), vapours or sulphuric gases, etc., could result in a drop in performance or damage of parts.
- Do not press switches with pointed objects.
Pressing with pointed objects could result in electric shocks or faults.
- Observe the working temperature range.
Always observe the working temperature range. Serious faults could result if the unit is used outside the working temperature range.
Refer to the specifications in the instruction manual for the working temperature range.
If not indicated in the instruction manual, the range is 0°C to 40°C (32°C to 104°F).
- Do not pull or twist the transmission cables
Doing so could result in fires or faults.
- Do not disassemble this unit.
Touching the internal PCBs, etc., is hazardous, and could result in fires or faults.
- Do not wipe this unit with benzene, thinner or chemical rags.
Using these matters could result in discoloration or faults. If the unit is heavily dirtied, wipe off with a cloth wetted in diluted neutral detergent, and then wipe again with a dry cloth.

GB

2. Names and functions of each part

2-1. Appearance

- This controller has two operation modes. One is the [COLLECTIVE STATUS DISPLAY Screen] for making operations and settings for all air conditioners, and the [GROUP STATUS DISPLAY Screen] for making operations and settings for air conditioners in each group. Refer to section 4. Operation methods (page 10) for details.

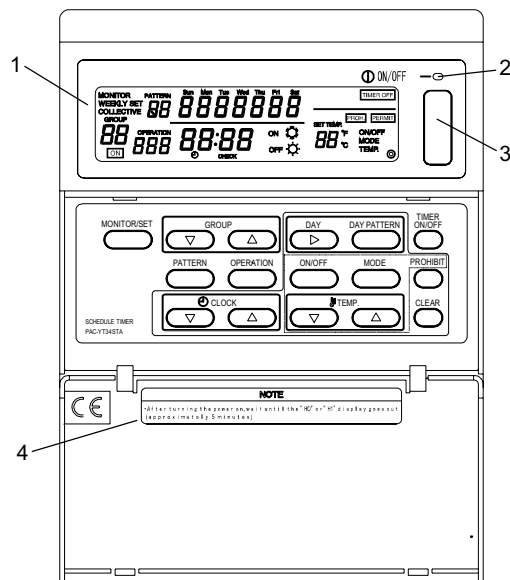

1. COLLECTIVE/GROUP DISPLAY

Indicates which mode is selected:

COLLECTIVE: [COLLECTIVE STATUS DISPLAY Screen]

GROUP: [GROUP STATUS DISPLAY Screen]

2. COLLECTIVE ON/OFF LAMP

ON: One or more group is running

(Also ON when a sequential unit is running)

OFF: All groups are stopped

Flicker: Registered air conditioner is malfunctioning

3. COLLECTIVE ON/OFF SWITCH

COLLECTIVE STATUS DISPLAY SCREEN/GROUP STATUS DISPLAY SCREEN

* If pressed when all groups are stopped, all groups will start running.

* If pressed when one or more groups are running, all groups will stop.

* If pressed when a registered air conditioner is malfunctioning, all groups will stop.

4. CAUTION

Remote control operations are not possible if "H0" or "H1" is displayed while the power is ON. (Approx. five minutes.)

2-2. Display sections

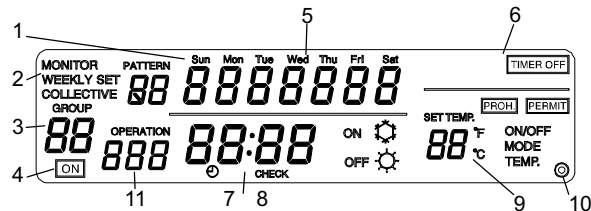

1. SCHEDULE PATTERN No.
The selected group's weekly schedule pattern No. is displayed.
The selected schedule pattern No. is displayed.
2. MONITOR/PROGRAM/WEEKLY PROGRAM DISPLAY
Monitor display: [PROGRAM MONITOR screen]
Program display: [PROGRAM SETTING screen]
Weekly program display: [WEEKLY PROGRAM SETTING screen]
3. GROUP NUMBER DISPLAY
The group number selected on the [Group Setting/WEEKLY PROGRAM SETTING Screen] is displayed.
4. OPERATION STATUS DISPLAY
The displayed group's operation status is displayed.
5. CURRENT DAY DISPLAY
The current day is displayed.
6. CONTROL STATUS DISPLAY
The currently controlled state is displayed.
7. CURRENT TIME DISPLAY
The current time is displayed.
8. ERROR CODE DISPLAY
If an error is occurring, the need for inspection is indicated and the error code (4-digit) is displayed.
9. OPERATION DETAILS DISPLAY
The details of schedule operation are displayed.
Operation details: ON/OFF, operation mode (cooling/heating), set temperature, operation prohibit (ON/OFF, operation changeover, room temperature adjustment)/enable
10. ☉ Display
This appears when the power is ON.
11. SCHEDULE OPERATION NO.
The selected schedule's operation No. is displayed.

2-3. Operation section

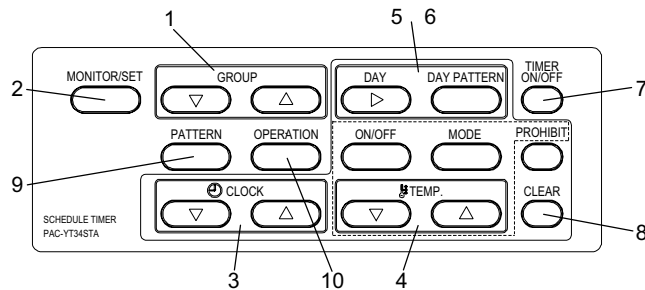

1. GROUP SELECT SWITCH

Press this to call the required group screen when making various settings.

2. MONITOR/SET SWITCH

Use this switch to change between the [NORMAL SCREEN], [PROGRAM MONITOR SCREEN], [PROGRAM SETTING SCREEN] and [WEEKLY PROGRAM SETTING SCREEN].

3. CLOCK SWITCH

Use this switch to set the current time and program time.

4. TEMP. SWITCH

Use this switch to set the schedule operation.

* ON/OFF: Select ON, OFF or no setting.

* Use this to start or stop the group independently or collectively.

* Operation changeover: Select cooling, heating or no setting.

* Set Temperature: Select set temperature or no setting.

* Prohibit: Select operation prohibit, enable or no setting.

5. DAY SWITCH

Use this switch to change the day for the [TIME/DAY SETTING] and [WEEKLY PROGRAM SETTING].

6. DAY PATTERN SWITCH

Use this switch to display the day pattern for [WEEKLY PROGRAM SETTING].

7. TIMER ON/OFF SWITCH

Use this switch to stop the schedule function for all groups currently being controlled.

8. CLEAR SWITCH

Use this switch to clear the program settings.

9. PATTERN SWITCH

Use this switch to set the schedule pattern No.

10. OPERATION SWITCH

Use this switch to set the schedule operation No.

2-4. Screen configuration

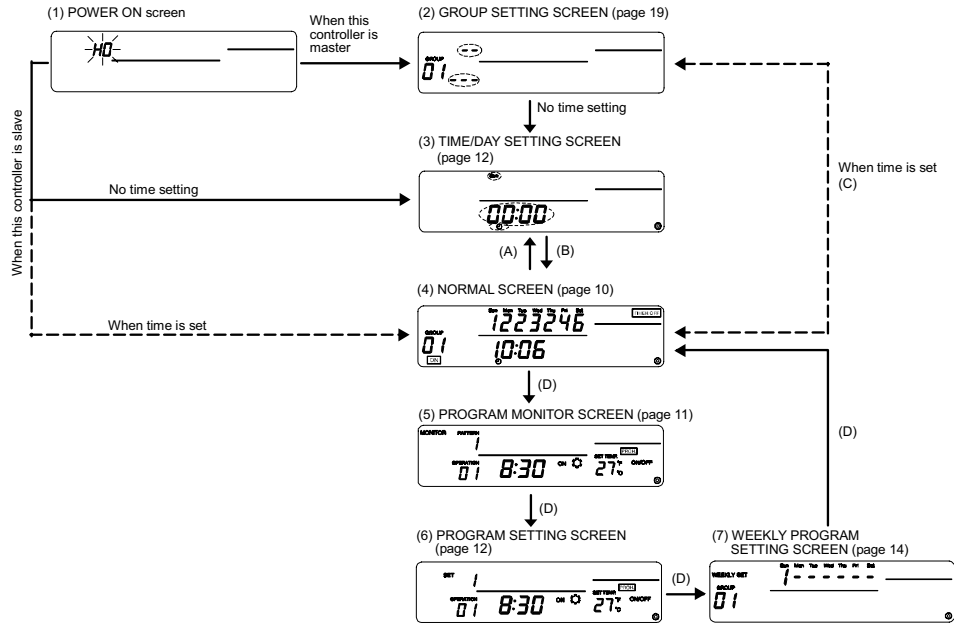

GB

■ Explanation of screens

1. POWER ON SCREEN

"H0" flickers if there is no group information. "H1" flickers if there is group information.

2. GROUP SETTING SCREEN

When this controller is the master, the group is set and changed.

3. TIME/DAY SETTING SCREEN

The current time and day are set.

4. NORMAL SCREEN

After setting the schedule, schedule operation is carried out with this screen.

In addition to schedule operation, the units can be started and stopped collectively or in groups.

5. PROGRAM MONITOR SCREEN

The set program contents are monitored.

6. PROGRAM SETTING SCREEN

The details of the schedule operation are set and changed.

7. WEEKLY PROGRAM SETTING SCREEN

The pattern set on the PROGRAM SETTING SCREEN is set and changed in day-units for each group.

■ Explanation of transition operations

A: Press time Δ and ∇ switches

B: Press ON/OFF.

C: Press TEMP. ∇ and CLEAR switches

D: Press MONITOR/SET switch

3. Outline of schedule setting and operation

3-1. Outline of setting

The schedule is set with this controller using the following procedures.

1. Setting of current time and day

2. Setting of program

Set the schedule pattern. (Up to nine types of operations patterns with 16 operations in each pattern can be set.)

[Setting example]

Pattern	Operation	Set time	Set details			
			ON/OFF	Mode	Set temp.	Operation prohibit
1	1	8:15	ON	Cool	29°C	Room temp. adjustment
	2	10:00	OFF	-	-	ON/OFF
	3	10:15	ON	-	27°C	Enable
	4	12:00	OFF	-	-	ON/OFF
	5	13:00	ON	-	25°C	Room temp. adjustment
	6	17:00	OFF	-	-	Enable
	16	21:00	OFF	-	-	ON/OFF
2	1	9:00	ON	-	27°C	Room temp. adjustment
	:	:	:	:	:	:
	16	22:00	OFF	-	-	ON/OFF
:	:	:	:	:	:	:
9	1	8:30	ON	Heat	22°C	Room temp. adjustment
	:	:	:	:	:	:
	16	21:30	OFF	-	-	ON/OFF

Set the time to start schedule operation, and the details of the operation.

With operation 1, cooling with the air conditioner is started at 08:15, operation is continued at 29°C, and adjustment of the room temperature with the local remote controller is prohibited.

3. Setting of weekly program

Set the schedule pattern set in step 2 in day-units for each group.

[Setting example]

Day Group	Sun.	Mon.	Tue.	Wed.	Thu.	Fri.	Sat.
1	Pattern 1	Pattern 2	Pattern 2	Pattern 2	Pattern 2	Pattern 2	Pattern 1
2	No setting	Pattern 3	Pattern 3	Pattern 4	Pattern 4	Pattern 5	Pattern 6
:							
50	Pattern 9	Pattern 7	Pattern 7	Pattern 8	Pattern 8	No setting	Pattern 9

Pattern 1 is used for the schedule operation on Sunday in group 1. Schedule operation is not carried out on Sunday in group 2.

3-2. Schedule operation

This controller carries out schedule operation at each set time.

[Operation example] The schedule operation for pattern 1 given as an example in step 2. Setting of program on the previous page is explained in this section.

- 8:15 - Start cooling operation at 29°C. Prohibit adjustment of the room temperature using the local remote controller.
- 10:00 - Stop the air conditioner. Cancel the local remote controller room temperature adjustment operation prohibit setting, and then prohibit ON/OFF operations.
- 10:15 - Resume operation at 27°C. Prohibit operation of the local remote controller.
- 12:00 - Stop the air conditioner. Prohibit ON/OFF operations using the local remote controller.
- 13:00 - Start cooling operation at 25°C. Prohibit adjustment of the room temperature using the local remote controller.
- 17:00 - Stop the air conditioner. Cancel the local remote controller room temperature adjustment operation prohibit setting.
- •
•
- 21:00 - Stop the air conditioner. Prohibit ON/OFF operations using the local remote controller. (The details set for the final operation will be held until schedule operation starts on the next day.)

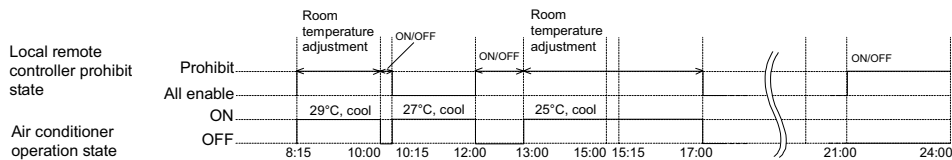

NOTE

1. Even if a schedule operation is being executed from this controller, the air conditioner can be operated using the local remote controller.
2. Operations when "operation prohibit" is set
If "operation prohibit" is set from another system controller, the schedule operation of the set prohibit item will not be executed.
The prohibit items set from the other system controllers are ON/OFF (ON/OFF), operation mode changeover (MODE) and room temperature adjustment (TEMP.).
3. Operation when "operation mode changeover limit (season changing)" is set
If "operation mode changeover limit (season changing)" is set from another system controller, "cooling/heating" operations following the schedule will not be executed.
When "cooling limit" is set, cooling operation following the schedule will not be executed.
When "heating limit" is set, heating operation following the schedule will not be executed.
4. Operation during power failure for this controller
The operations set in the schedule will not be executed during a power failure. When the power is recovered, operation will resume with the schedule active after the restoration time. Note that if the schedule operation contains "operation prohibit", the current state set in the schedule will be restored.

4. Operation methods

4-1. Normal screen

(COLLECTIVE/GROUP STATUS DISPLAY SCREEN)

- Display Schedule pattern for each group (Only on the Group Status Display screen).
 - * Current time/day
 - * Air conditioner ON/OFF state
 - * Limits and prohibit states set from other system controllers
 - * Control state
- Operation The air conditioner can be turned ON or OFF collectively or in group units. The schedule function can be stopped for all groups collectively.

[COLLECTIVE DISPLAY SCREEN]

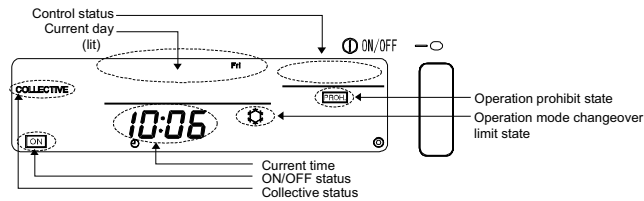

[GROUP STATUS DISPLAY SCREEN]

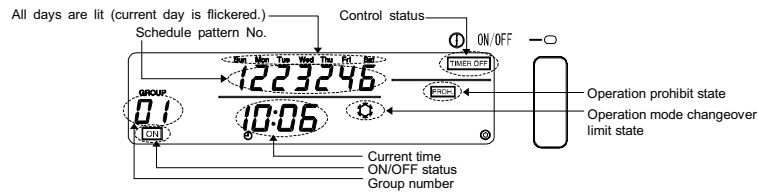

4-1-1. Group selection operation

- (1) Press the GROUP Δ and ∇ switches to select the group to be operated. The group No. displayed at the group No. display section will change as shown below each time the GROUP Δ switch is pressed.

“ Collective ” → “ 1 ” → “ 2 ” → “ 3 ” → → “ 50 ”

The group No. will change in reverse each time the GROUP ∇ switch is pressed. When the GROUP Δ and ∇ switches are pressed simultaneously, the "Collective Status Display screen" will open regardless of the selected group No. When "Collective" is selected, the "Collective Display screen" will open. When "Group No." is selected, the screen for the selected group will open. When the Group Status Display screen is opened, the weekly schedule pattern for the selected group will display. The current day will flicker. If no operations are made on the Group Status Display screen for ten minutes, the display will switch to the Collective Status Display screen.

4-1-2. ON/OFF operations

- (1) Select the group of collection state to be operated with the step "Group selection operation" above.
- (2) Press the (ON/OFF) switch.
 [ON] will appear at the ON/OFF status display when the controller is running. Nothing will appear when the controller is stopped.

4-1-3. Stopping the schedule operation collectively for all groups

- (1) Hold down the (TIMER ON/OFF) switch for three seconds.
 [TIMER OFF] will appear at the control status display section when the schedule operation is stopped, and the schedule operation will stop.
 [TIMER OFF] will not appear during schedule operation.
 When an emergency stop is input, [TIMER OFF] will flicker.
 The (TIMER ON/OFF) switch operation is invalid while [TIMER OFF] is flickering.

4-1-4. Display

- (1) (PROHIBIT) will appear when "operation prohibit" is set from another system controller. If ON/OFF operation prohibit is set, the operation cannot be started or stopped from this controller.
- (2) If "operation mode changeover limit (cooling limit) is set from another system controller, (cooling limit) will flicker.
 (heating limit) will flicker when "operation mode changeover limit (heating limit)" is set.

4-2. PROGRAM MONITOR screen

- The set program details are monitored.

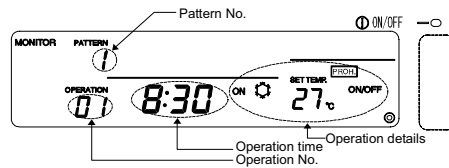

Monitoring the set program details

- (1) Open the PROGRAM MONITOR screen.
 Press the (MONITOR/SET) switch on the Normal screen. ("MONITOR" will appear at the upper left when the screen is opened.)
- (2) Set the pattern No.
 The pattern No. displayed at the pattern No. display section will change as shown below each time the (PATTERN) switch is pressed. (Patterns that are not set will not appear.)

 " 1 " → " 2 " → " 3 " → " 9 "
 ↑
- (3) Set the operation No.
 The operation No. will change in the order of set times each time the (OPERATION) switch is pressed. (Operation numbers that are not set will not appear.)
- (4) The details of the program having the set pattern and operation numbers will appear.

NOTE On this screen, each operation is sorted and displayed in order of the set time.

4-3. TIME/DAY SETTING screen

- The current time and day are set and changed on this screen.
- A time notification can be issued. (A time notification is issued to collectively set the current time of system controllers and remote controllers having a clock function.)

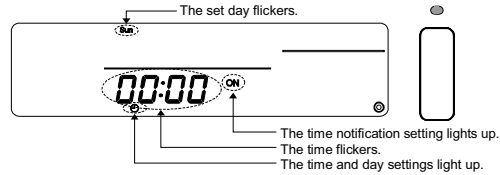

- (1) Open the TIME/DAY SETTING screen.
Press the CLOCK ∇ and Δ switches simultaneously on the Normal screen.
- (2) Set the time.
 1. The clock will advance by one minute when the CLOCK Δ switch is pressed once. When the switch is held down, the time will advance in one-minute increments, ten-minute increments and one-hour increments.
 2. The clock will return by one minute when the CLOCK ∇ switch is pressed once. When the switch is held down, the time will return in one-minute increments, ten-minute increments and one-hour increments.
- (3) Set the day.
The day displayed in the day display section will flicker in the order of Sunday, Monday, Tuesday ... Saturday, Sunday each time the DAY \triangleright switch is pressed.
- (4) Set the time notification.
The display at the time notification setting and display section will change as shown below each time the MODE switch is pressed.

“ No display ” \rightarrow “ ON ”

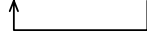

* Set this to "ON" when a time notification is to be issued.

- (5) The set clock, day and time notification can be cleared to the previous values by pressing the CLEAR switch.
- (6) The set time, day and time notification settings will be input when the ON/OFF switch is pressed. (The seconds unit will be set to 0 seconds.)
If the time notification is enabled, the time input with this operation will be notified.

- NOTE**
1. To cancel the setting, carry out step (1) to return to the Normal screen. The changes made to the time setting will be cancelled.
 2. The Program Setting screen and Weekly Program Setting screen cannot be opened if the time and day are not set.

4-4. PROGRAM SETTING screen

- The details of the schedule operation are set and changed.

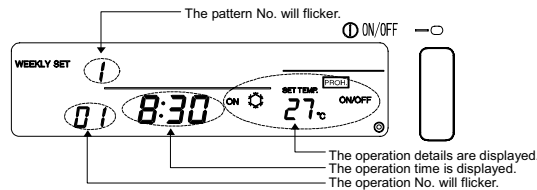

4-4-1. Setting the program

- (1) Open the PROGRAM SETTING screen.
Press the **MONITOR/SET** switch on the PROGRAM MONITOR screen. ("PROGRAM" will flicker at the upper left when this screen is opened.)
If no operations are made on this screen for ten minutes, the display will switch to the Normal screen.

“ 1 ” → “ 2 ” → “ 3 ” → “ 9 ”
- (2) Set the pattern No. displayed at the pattern No. display will change as shown on the right each time the **PATTERN** switch is pressed.

“ 01 ” → “ 02 ” → “ 03 ” → “ 16 ”
- (3) Set the operation No.
The operation No. displayed at the operation No. display will change as shown on the right each time the **OPERATION** switch is pressed.
- (4) Set the operation time.
 1. The clock will advance by five minutes when the **CLOCK** **▲** switch is pressed once. When the switch is held down, the time will advance in five-minute increments or sixty-minute increments.
 2. The clock will return by five minutes when the **CLOCK** **▼** switch is pressed once. When the switch is held down, the time will return in five-minute increments or sixty-minute increments.

4-4-2. Setting the operation details

- Set the details to be operated at the time set in the previous section.
 - Display only the details to be set.
- (1) Set ON/OFF.
The state will change as shown on the right each time the **ON/OFF** switch is pressed.
Set to "No display" if this setting is not required.

“ No display ” → “ ON ” → “ OFF ”
 - (2) Set the operation mode.
The mode will change as shown on the right each time the **MODE** switch is pressed.
Set to "No display" if this setting is not required.

“ No display ” → “ ” → “ ”
 - (3) Set the temperature.
 1. The temperature will change as shown below each time the **TEMP.** **▲** switch is pressed. The temperature will change continuously in 1□ increments when the switch is held down.
“ -- ” → “ 19 ” → “ 20 ” → . . . → “ 28 ”
 2. The temperature will change as shown below each time the **TEMP.** **▼** switch is pressed. The temperature will change continuously in 1□ increments when the switch is held down.
“ -- ” → “ 28 ” → “ 27 ” → . . . → “ 19 ”
 - (4) Set operation prohibit.
The DIP switches must be set to prohibit operations following the schedule with this controller. Refer to section 8. Setting the functions.
 1. Set whether to prohibit or enable operations with the local remote controller.
The state will change as shown below each time the **PROHIBIT** switch is pressed.
“ No display ” → “ **PROH.** ” (flickers) → “ **PROH.** ” (ON) → “ **PERMIT** ”

(To not set	: Leave the display at "No display".
	To set prohibit:	Set to PROH. (flicker) and set the prohibited item.
	To enable	: Set to PERMIT (lit) All items will be permitted when set to PERMIT .

(This operation is invalid if the SW3 "operation prohibit" is set to "Invalid". (Always a no display state.)
When **PROH.** is displayed, the prohibited "ON/OFF", "MODE" and "TEMP." items will display.)

2. Set the item to be prohibited. (The item can be set by simultaneously pressing the switch for the item to be set while "PROHIBIT" flickers.)
 - To prohibit ON/OFF : Press the **ON/OFF** switch. The ON/OFF display will change.
 - To prohibit operation mode changeover : Press the **MODE** switch. The OPERATION CHANGEOVER display will change.
 - To prohibit room temperature adjustment: Press the **TEMP** switch. The ROOM TEMPERATURE ADJUSTMENT display will change.
3. Input the details of the prohibit setting.
 - After step 2, light up the items to be prohibited, and then press the **PROHIBIT** switch.
 - The **PROHIBIT** switch will change from flicker to ON, and the set details will be input.
- (5) Input the operation details.
 - Press the **OPERATION** switch.
 - The operation details will be input and the operation No. will be incremented by one.

4-4-3. Deleting an operation setting

- (1) Select the operation No. to be deleted.
 - Refer to section 4-4-1 (2) and (3) for the selection methods.
- (2) Delete the settings.
 - Press the **CLEAR** switch twice in succession.
 - The displayed operation setting details will be deleted. (The default state will be set.)

4-4-4. Copying the details of a pattern setting

- All of the operation details of a set pattern can be copied into another pattern. (Example: The details set for pattern 1 can be copied to pattern 2. In this case, the contents of pattern 2 will be overwritten.)
- (1) Select the pattern number to be copied, and display in the display section.
 - (2) Hold down the **DAY PATTERN** switch for two or more seconds. The details set for the copy origin pattern will be saved.
 - (The operation time and details display sections will flicker.)
 - (3) Select the copy destination pattern No., and display in the display section.
 - (4) Hold down the **DAY** switch for two or more seconds. The setting details saved in step (2) will be copied to the copy destination.
 - (The operation time and details display sections will light.)

To cancel copying of the pattern, hold down the **DAY PATTERN** switch for two or more seconds after step (1) or (3).
 (The operation time and details display sections will turn ON. If the operation is cancelled after step (3), the pattern No. will return to the copy origin No.)

4-5. WEEKLY PROGRAM SETTING screen

- Set the schedule pattern, set in section 4-3, for each day in each group.
- All of the set schedules are deleted.

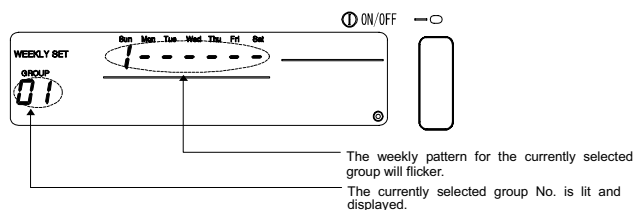

4-5-1. Setting the operation pattern

- (1) Open the WEEKLY PROGRAM SETTING screen.
Press the **MONITOR/SET** switch on the PROGRAM SETTING screen.
("WEEKLY SET" will flicker on the left of the screen when the screen changes.)
If no operations are made on this screen for ten minutes, the display will switch to the Normal screen.

(2) Selecting the group No.

- 1. The group No. displayed at the group No. display will change in the following order each time the GROUP **▲** switch is pressed. (The display will change in a one-second cycle when the switch is held down. Group numbers that are not set will not appear.)

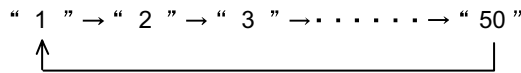

- 2. The display will change in reverse when the GROUP **▼** switch is pressed.

NOTE With this controller, the pattern can be set regardless of the unit models in the group.
Example: A heating operation pattern can be set for a group consisting only of cooling dedicated models.
When setting a weekly program, check the unit models in the group and the pattern setting details.

(3) Selecting the set day

The pattern No. displayed at the weekly pattern setting No. display will change in the following order each time the DAY **▶** switch is pressed.
(The selected day pattern will flicker.)

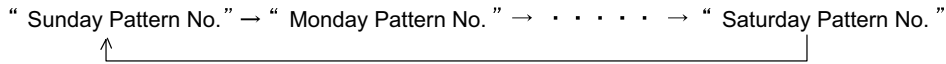

(4) Selecting the day No.

Each flickering pattern No. will change in the following order each time the **DAY PATTERN** switch is pressed.
"--" indicates that no pattern is set.
(Pattern numbers that are not set will not appear.)

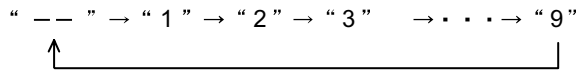

(5) Deleting a weekly pattern

The details of the selected group's weekly program will be deleted (no pattern will be set) when the **CLEAR** switch is pressed twice in succession.

(6) Deleting all set schedule details

All details set for the program and weekly program can be deleted by holding down the **MODE** switch for three or more seconds.

5. Troubleshooting

5-1. When "COLLECTIVE ON/OFF LAMP" and "ERROR CODE" are flickering

- The air conditioner is stopped because a problem has occurred and operation cannot be continued.
- Check the address of the unit where the error is occurring and the error code, and call your nearest MITSUBISHI ELECTRIC supplier or dealer.

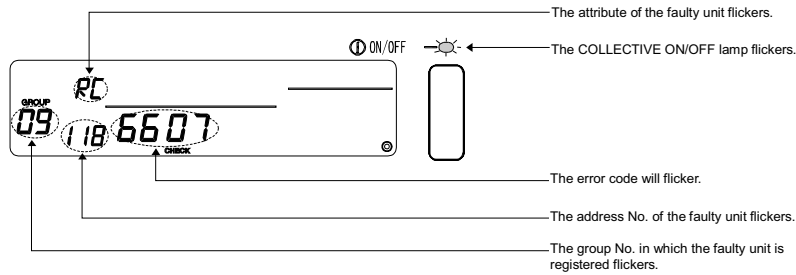

1. If an error occurs while the [COLLECTIVE DISPLAY SCREEN] is displayed, the details of the error for the group with the first faulty will appear.
2. If an error occurs while the [GROUP STATUS DISPLAY SCREEN] is displayed, only the details of the error for the currently selected group will appear.

- Confirming the details on an error for a different group

Using the **GROUP** switch, select the group with the error and check the displayed error details.

NOTE If an error occurs in a group other than that displayed on the [GROUP STATUS DISPLAY SCREEN], the COLLECTIVE ON/OFF lamp will flicker.

5-2. When only the "Error Code" is flickering

- The air conditioner will continue running, but there may be a problem.
- Check the error code and call your nearest MITSUBISHI ELECTRIC supplier or dealer.

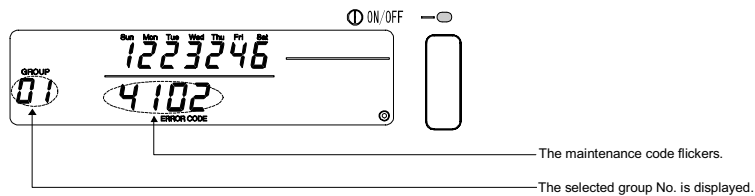

1. If an error occurs while the [COLLECTIVE DISPLAY SCREEN] is displayed, the details of the error for the group with the first problem will appear.
2. If an error occurs while the [GROUP STATUS DISPLAY SCREEN] is displayed, only the details of the error for the currently selected group will appear.

6. External input and output functions

When using the external input and output cables provided with the remote controller. (5-wire cable for input and 4-wire cable for output are provided.)

6-1. External input

6-1-1. Emergency stop input mode

- If an emergency stop signal is input in the external input interface, all air conditioners and LOSSNAY units being controlled will stop. This controller, slave system controller and local remote controller operations will be prohibited until the emergency stop input is cancelled.

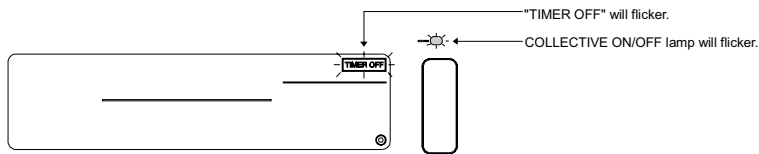

GB

- NOTE**
- The timer is invalid while this mode is input, and the schedule function will stop.
 - When this mode is cancelled, the timer will be validated, and schedule operation will resume. The schedule following the current time will be started.

6-1-2. ON/OFF level signal input mode

- If the ON/OFF level signal is input in the external input interface, all air conditioners and LOSSNAY units being controlled will be turned ON or OFF. This controller, slave system controller and local remote controller operations will be prohibited until this mode is cancelled.

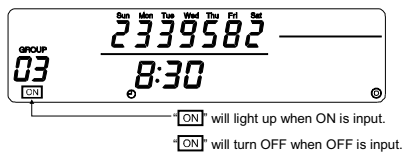

- NOTE** When this mode is set, ON/OFF operations following the schedule from this controller will not be executed. (Other schedule settings will be executed.)

6-1-3. ON/OFF, operation prohibit/permit pulse input mode

- If the ON/OFF signal is input in the external input interface, all air conditioners and LOSSNAY units being controlled will be turned ON or OFF.
- If the prohibit/permit signal is input in the external input interface, the slave system controller and local remote controller operations will be prohibited or permitted.

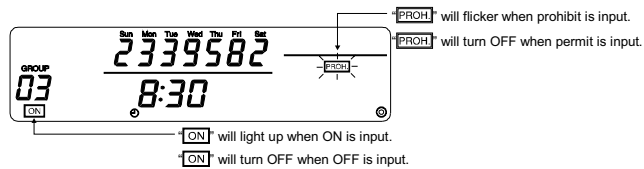

- NOTE**
1. The timer is valid even when this mode is input, and the schedule operation will be executed.
 2. The prohibit/permit setting range follows the DIP SW3-5 setting state. Refer to section 8. "Setting the functions" for details on the DIP switches.

6-2. External output

- The "ON" signal is output when more than one air conditioner is ON, and the "Error Occurrence" signal is output when an error is occurring in more than one air conditioner.

7. Initial settings

- When connecting multiple system controllers, designate the system controller with many functions as the "master", and set the system controllers with few functions as the "slaves". (Refer to section 8. Setting the functions, "8-1 Using with master system controller" for details on the "master/slave" settings.)
- If this system is controlled by the master system controller, carry out the initial settings with the master system controller. In this case, this system will use the slave settings, and does not require initial settings.

7-1. When this controller is master system

The initial settings include the following items:

- Group setting
- Interlocked unit setting

Open the Initial Setting Mode Screen to make these settings.

(1) The following display will appear when the power to this controller is turned ON.



© "H0" on the group No. display section and the COLLECTIVE ON/OFF lamp will flicker.

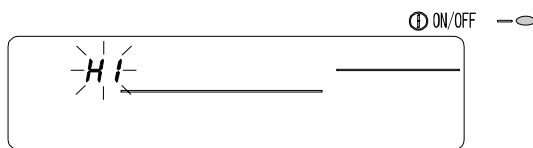

(2) When group setting information is already set

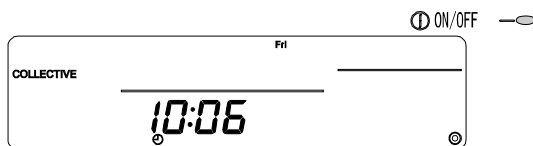
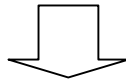

© During system startup communication, "H1" will flicker at the group No. display section.



© When system startup communication is completed, the NORMAL screen will open.

(3) When there is no group setting information or when the group setting information is changed Press the TEMP.  and  switches simultaneously while "H0" shown in step (1) is flickering or when all groups are stopped with the NORMAL screen or GROUP DISPLAY screen shown in step (2).

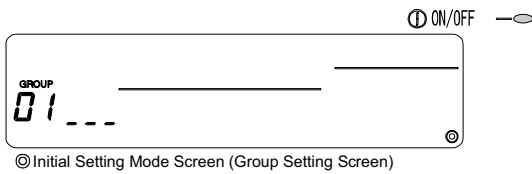
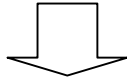
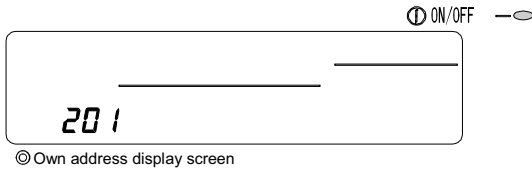

NOTE When opening each screen from step (2), if there is an error in any group, the switch operation will be invalid.

This controller's own address will flicker for two seconds.



Carry out steps 7-1-1 to 7-1-2 from the state shown above.

(4) Cancel the initial setting mode.

- After setting the group and the interlocked unit, hold down the TEMP.  and  switches simultaneously.
 - Save the group setting information and interlocked unit setting information, etc., with this step, and then carry out system startup communication. The Group Setting/Monitor Screen will open when completed. (Refer to step (2).)
 - If no operations are made on this screen for ten minutes, the display will automatically switch to the Normal screen.
- Note that if the group setting information has not been saved, the screen will not change automatically.

NOTE Do not turn the power OFF during system startup communication (while "H1" is flickering). (The group setting information, etc., will not be saved in the memory if the power is turned OFF.)



7-1-1. Setting the group

- Register the indoor unit, LOSSNAY, slave system controller and local remote controller for each group. (Register the LOSSNAY to be interlocked with the indoor unit using the interlocked unit setting.)

1. Select the group.
- ↓
2. Select the unit.
- ↓
3. Registering the group into the unit
4. Searching for registered units
5. Deleting a unit from a group

Go to step 7-1(4) or 7-1-2.

1. Select the group.

- (1) The group No. displayed in the group No. display will change each time the GROUP  switch is pressed. The numbers will display in reverse when the  switch is pressed.
- (2) After the group is selected, if a unit is registered in the group the minimum address No. unit will appear. The attributes for that group will appear after two seconds.

Displayed details { Operation No. display section ... Address No.
Pattern No. display section ... Address No. attributes

Example) When groups 1 and 2 are not registered, and the address 005 indoor unit is registered in group 3

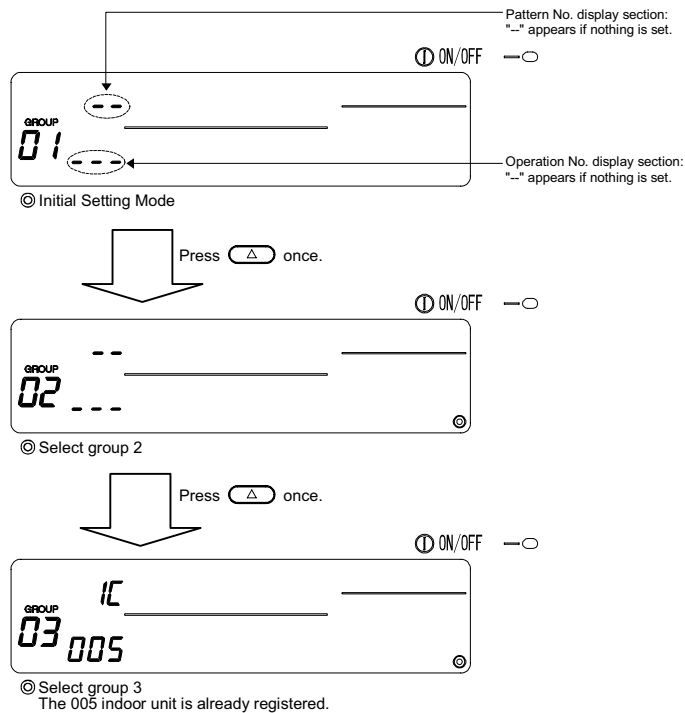



2. Selecting the unit

(1) Select the unit to be registered in the group selected in step 1.

- The address No. displayed in the operation No. display section will change in the following order each time the TIME  switch is pressed. (The numbers will change in 10-unit increments when the switch is held down.)

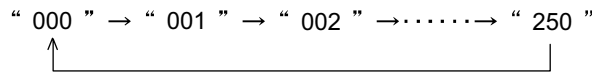
“ 000 ” → “ 001 ” → “ 002 ” → → “ 250 ”



- The numbers will appear in reverse order when the TIME  switch is pressed.

Address No. setting range	Indoor unit, LOSSNAY	:	001 to 050
	Local remote controller	:	101 to 200
	Slave system controller	:	000, 201 to 250

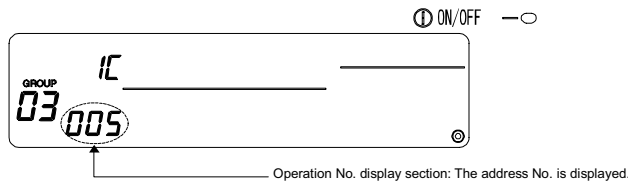

(2) When registered unit is selected

- The following will display when the selected unit is already registered in a group controlled with this controller.

Example) When unit 011 (registered in group 23) is called with group 3

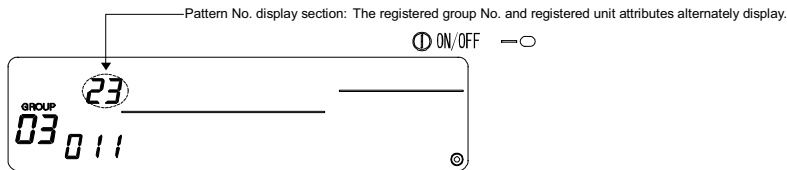

3. Registering the unit into a group

(1) Register the unit selected in step 2 into a group.

- With the group No. and unit address selected in steps 1 and 2 displayed, press the  switch.
- The registration process will be completed with this step.
- The address No. and attributes will appear when correctly registered.

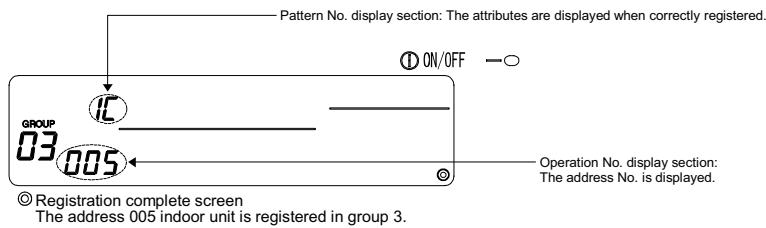

(2) Registering a separate unit

- Carry out steps 2 and 3 to register a different unit in the same group.
- Carry out steps 2 and 3 to register a unit in another group.

NOTE A LOSSNAY unit cannot be registered in a group containing indoor units. When registration is attempted, these will not be correctly registered and "88" will flicker on the screen. If the indoor unit, LOSSNAY, and local remote control are already registered in another group, they cannot be registered in a different group. However, the slave system controller can also be registered in a different group.

4. Searching for registered units

The address numbers of all units registered in a group can be checked.

- (1) Using step 1, select the group to be searched.
- (2) The address numbers of the registered units will appear in order of smallest number each time the (PROHIBIT) switch is pressed.

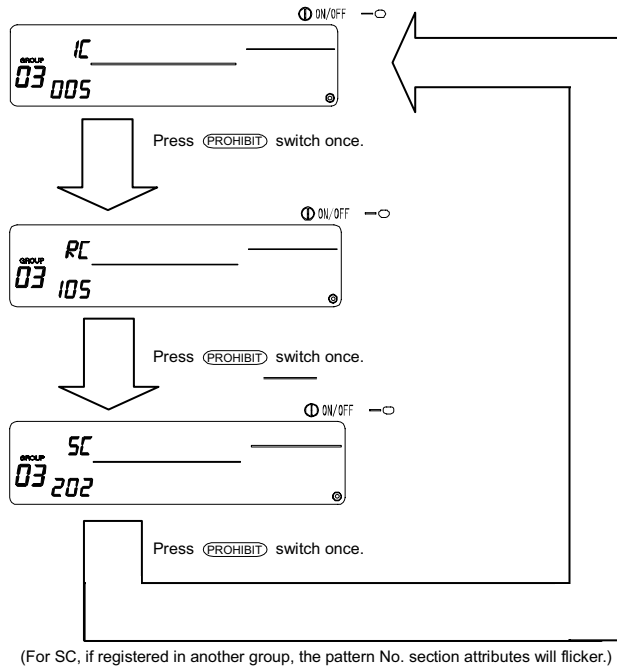

- (3) If a single unit is not registered, "---" will display.

5. Deleting a unit from a group

- (1) Using steps 1 and 2, call out the address No. of the unit to be deleted.

- When the (CLEAR) switch is pressed twice in this state, the unit registered in the group will be deleted.

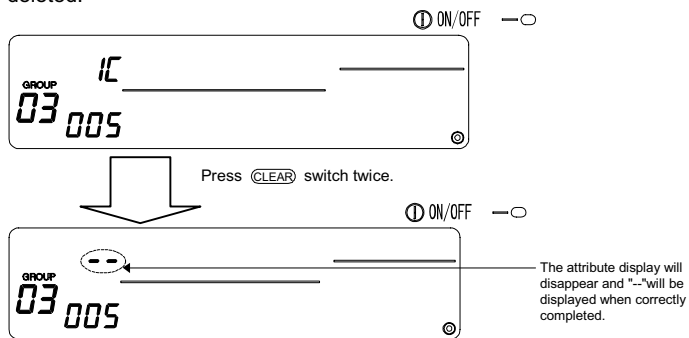

7-1-2. Setting the interlocked units

- Set that units interlocked with each group can be run in linked.
- Set the interlocked unit after setting each group.

The interlocked units cannot be set until the units are registered in the group in which interlocked units are to be set.

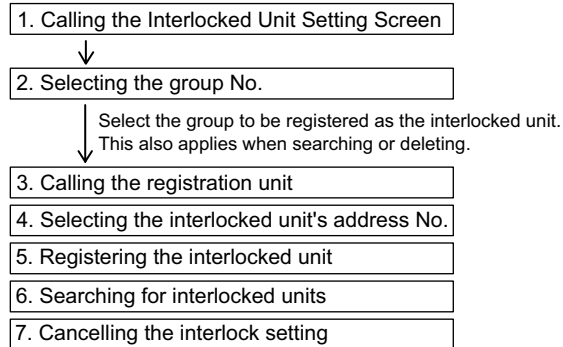

Go to step 7-1(4) or 7-1-1.

- NOTE**
- When registering the interlocked unit, if an indoor unit and interlocked unit in a certain group are to be linked, always register the indoor unit with the smallest address No. in the group for interlocking. If the unit is not registered for interlocking, the interlocked unit cannot be operated with the local remote controller.
 - If there are several indoor units to be linked with the interlocked unit, register all indoor units for interlocking.

1. Calling the Interlocked Unit Setting Screen

- (1) Open the Interlocked Unit Setting Screen from the Group Setting Screen.
Press the **MONITOR/SET** switch.

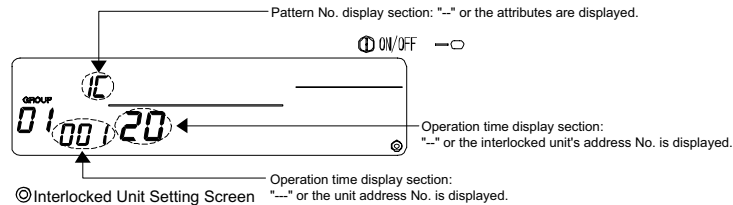
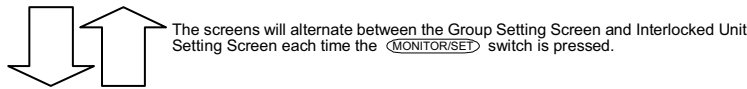
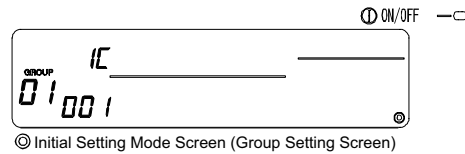

2. Selecting the group No.

(1) Call the Group No.

- Call the group No. in which the interlocked unit is to be registered.
Use the same operations as section 7-1-1. (1) Select the group.
- Select the group with the GROUP (▽) and (△) switches.

(2) When the group is selected, the corresponding group No. will appear at the group No. display section.

(3) After the group is selected, if there are registered units, the registered unit with the smallest address No. will appear.

Displayed details { Set temperature display section ... Address No.
Group No. display section ... Address No. attributes

Example) When group 1 is not registered, and the address 003 indoor unit is registered in group 2.

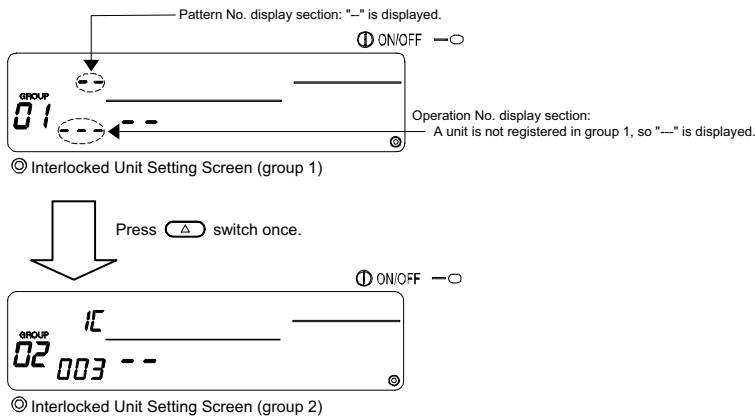

3. Calling the registration unit

Call the address No. of the indoor unit to be interlocked with a registered interlocked unit by pressing the ON/OFF switch.

4. Selecting the interlocked unit's address No.

Set the address No. of the interlocked unit to be registered with the indoor unit selected in step 3.

- After selecting the indoor unit with step 3, press the TIME (△) switch.
- The address No. of the interlocked unit will change in the following order each time the switch is pressed. (The numbers will change in 10-unit increments when the switch is held down.)

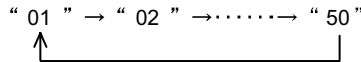

- The address numbers will appear in reverse order when the (▽) switch is pressed.

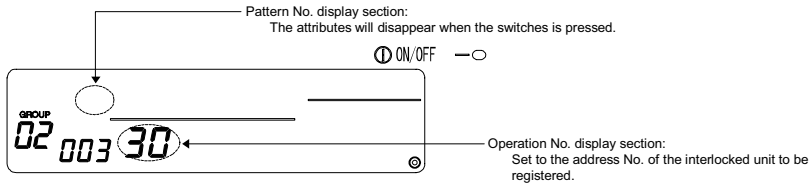

5. Registering the interlocked unit

(1) When the **(ON/OFF)** switch is pressed in the state shown in step 4, the interlocked unit will be registered as interlocked to the displayed indoor unit.

- The following type of display will appear when the unit is correctly registered.

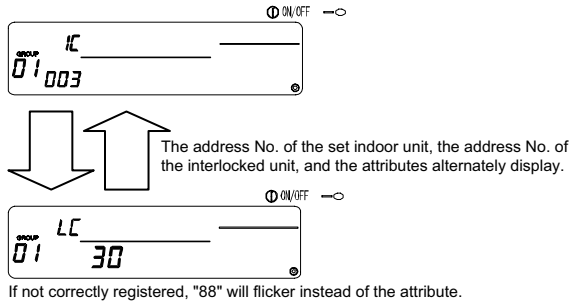

(2) Set the next interlocked unit

- Carry out steps 3, 4 and 5 to register a different indoor unit in the same group to the interlocked unit.
- Carry out steps 2, 3, 4 and 5 to register an indoor unit in a different group to the interlocked unit.
- Carry out steps 2, 3, 4 and 5 to register a different indoor unit to a different interlocked unit.

6. Searching for interlocked units

Search to find which indoor unit the interlocked unit is linked to.

(1) Carry out step 4 to display the address No. of the interlocked unit for which the setting is to be confirmed.

- Select the interlocked unit with the **(PROHIBIT)** switch

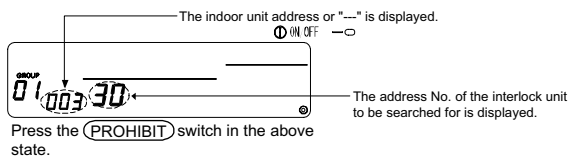

(2) When interlocked unit is set

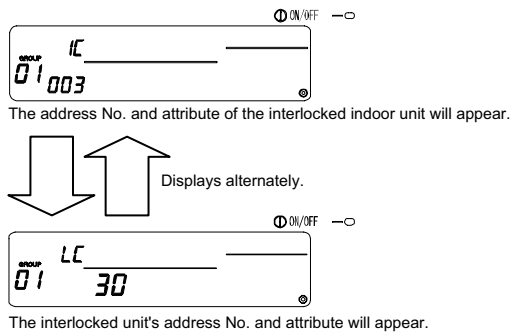

- If the **(PROHIBIT)** switch is pressed again in this state, the other units linked to the interlocked unit can be confirmed.

Example)

Indoor unit..... 001 (group 1)
 002 (group 2)

The following details are searched for.

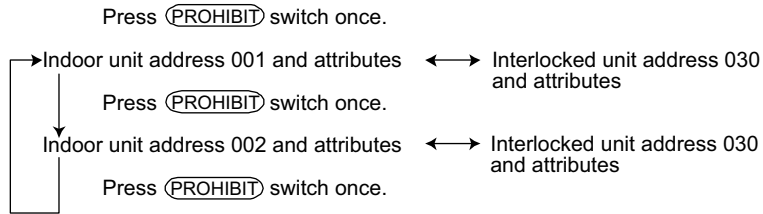

(3) When no unit is linked to the interlocked unit

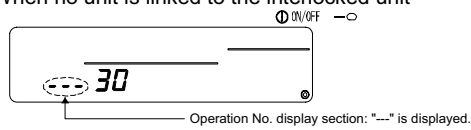

7. Canceling the interlock setting

Cancel the interlock setting of the indoor unit and interlocked unit.

(1) Call out the screen displayed after the interlocked unit is set, or the screen on which the interlocked unit was searched.

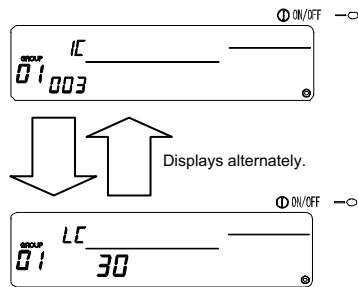

(2) The interlock setting will be cancelled when the (CLEAR) switch is pressed twice in this state.

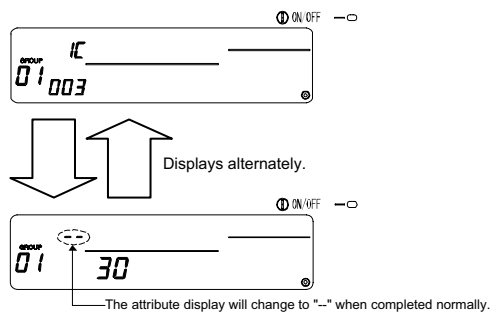

7-1-3. Collective deletion

- All group setting information and interlocked unit setting information can be deleted. This function is valid only when this controller is the master.

- (1) Display the Group Setting Screen or Interlocked Unit Setting Screen.
- (2) All set information will be deleted when the (MODE) switch is held down for three or more seconds in this state.

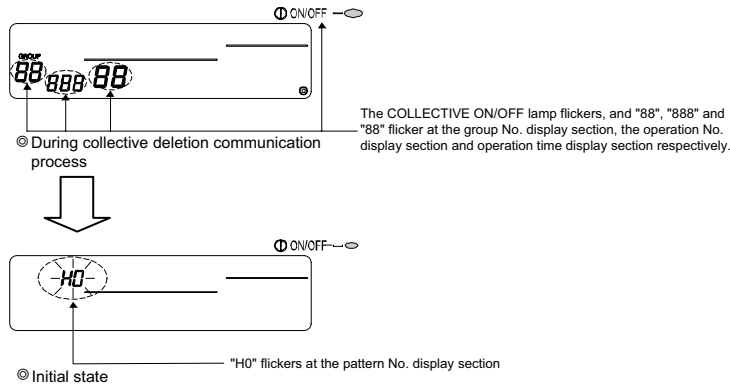

8. Setting the functions

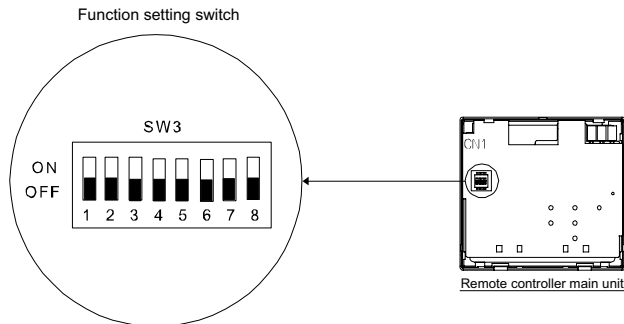

8-1. Using with master system controller

- When connecting multiple system controllers, the system controller with many functions is designated as the "master", and the system controller with few functions is designated as the "slave". The "master/slave" functions of the system controller used together are as follows.

The functions have a priority in order of G-50A (MJ-103MTR-A) > PAC-SF44 SRA > PAC-YT34STA > PAC-YT40ANRA > PAC-SC30GRA > LMAP02-E.

Setting details	Switch setting
Master side	SW3-1: OFF
Slave side	SW3-1: ON

8-2. Using the external input/output function

Prepare an external input/output adaptor to use the external input/output function.

This function cannot be used when the "local remote controller operation prohibit" is set to prohibit. Note that the external emergency stop input can be used.

(1) External input functions

Emergency stop/Normal, ON/OFF and local remote control prohibit/enable control can be applied to all units being controlled by inputting the no-voltage contact signal from an external source.

Set the switches as shown below.

Setting details	Switch setting	
	SW3-2	SW3-3
Do not use external input	OFF	OFF
Carry out Emergency stop/Normal with level signal	OFF	ON
Carry out ON/OFF with level signal	ON	OFF
Carry out ON/OFF and prohibit/permit with pulse signal	ON	ON

(2) External output function

The "ON" signal is output when more than one air conditioner is running, and the "Error Occurrence" signal is output when an error is occurring in more than one air conditioner.

* Please refer to the Installation Manual for details.

8-3. Disabling the local remote controller's operations from this controller

Resetting of the filter sign with the manual remote control can be disabled.

Setting details	Switch setting
Disable	SW3-4: OFF
Enable	SW3-4: ON

8-4. When local remote controller and system controller are prohibited

Setting details	Switch setting
Only local remote controller	SW3-5: OFF
Local remote controller and system controller	SW3-5: ON

* This setting is valid only when SW3-4 is ON.

8-5. Changing set temperature display to "Fahrenheit display"

Setting details	Switch setting
Celsius display: °C	SW3-6: OFF
Fahrenheit display: °F	SW3-6: ON

NOTE When the DIP switch 3 setting has been changed between ON and OFF, always turn the power OFF once.

The function will not change just by changing the switch setting.

The function will change after turning the power OFF and ON.

9. System limits

Master system controller and slave system controller

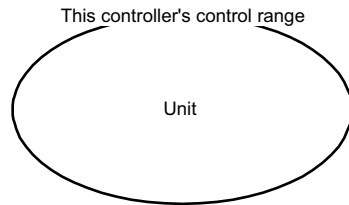

When the system contains only this controller. This controller is set as the master system controller. In this case, the group is set with this controller.

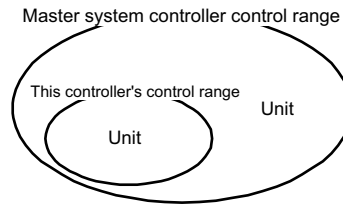

When this controller is controlled by another system controller. This controller is set as the slave system controller. In this case, the group is not set with this controller.

NOTE The following types of group settings are not possible.

- Control by the slave system controller of a unit not within the control of the master system controller.

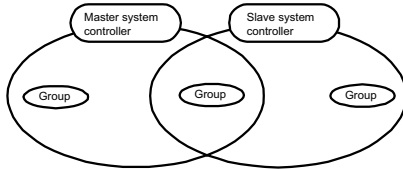

- Control of a common group with two or more master system controllers.

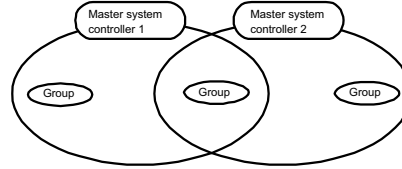

- Setting of a slave system controller exceeding the control range of two or more master system controllers.

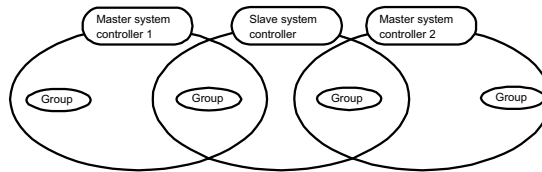

10. Specifications

10-1. Product functions

- This controller can control up to 50 air conditioners and LOSSNAY with a daily schedule either collectively or in groups.
- This controller has only a schedule setting function and must be used with another system controller. When used independently, only the air conditioner's ON/OFF status and error status will be monitored (operation status display). In addition to schedule setting, the units can be turned ON/OFF and stopped and the timer can be reset either collectively or in groups with switch operations.

The details of the functions are listed below.

<List of system remote controller functions>

Function		Details		
Normal functions	Operation	ON/OFF	ON/OFF operations can be carried out collectively or for each group.	
		Timer reset (*4)	The timer setting details can be disabled collectively.	
	Timer	Setting details	ON/OFF COOL/HEAT Room temperature adjustment (TEMP.) Operation prohibit (ON/OFF, operation mode, setting temperature)	
		Number of settings	Number of setting patterns: 9 (Operation for a week can be set by selecting one of nine patterns for each day.) Number of operations: Up to 16 operations can be set in one pattern.	
		Time setting unit	The item can be set in five-minute units.	
	Monitor	Time	The current time and day can be displayed.	
		Error	The address of the faulty unit and the error code are displayed on the LCD.	
		ON/OFF status (*5)	The ON/OFF status of the unit is displayed on the LCD when GROUP is selected.	
	Default setting function	Operation	Group setting	Set the unit (indoor unit, LOSSNAY, remote controller, slave system controller) group.
			Interlocked unit setting	Set the LOSSNAY and indoor unit interlock.
System (*3)		Master system controller/Slave system controller (*1)	Set the master and slave system controllers.	
		Operation prohibit setting Enable/disable	Set whether to prohibit operation with the local remote control using this controller or with another controller.	
		Celsius/Fahrenheit display	Set the set temperature display to a Celsius or Fahrenheit display.	
		Prohibit range	To prohibit an operation, set whether to prohibit only the remote controller or to also prohibit the other controllers.	
		System remote control own address	Set the schedule timer's address (Refer to the Installation Manual.)	
External input		Emergency stop level input, ON/OFF level input, ON/OFF and operation prohibit/enable pulse input		
External output		ON/OFF status output, error/normal state output		
System limits	Number of registered units	Indoor unit, LOSSNAY	Maximum 50 units	
		Number of indoor units and LOSSNAY in one group	1 to 16 units (The indoor unit and LOSSNAY cannot be registered in the same group.)	
		Number of local remote controls in one group	0 to 2 units	
		Number of system controllers that can be controlled by one group (*2)	0 to 4 units (Note that this includes the number of local remote controllers used in one group) 0 to 3 units in a group having one local remote controller	
		Number of indoor units interlocked with one LOSSNAY	0 to 16 units	

(*1) Refer to page 30.

(*2) This controller (schedule timer) is one of the system controllers.

(*3) Refer to page 28.

(*4) Check the operation status (operation mode, set temperature, etc.) of other air conditioners with the system controller being used.

(*5) These displayed details are the schedule setting details. These are not the air conditioner operation status monitor details.

10-2. Main specifications

Item	Details
Power source	30VDC (supplied from outdoor unit or power supply unit for transmission line (type: PAC-SC34KUA)).
Power consumption	1W
Working environment conditions	Temperature 0 to 40°C, humidity 30 to 90%RH (with no dew condensation)
Weight	0.2kg
Outline dimensions (H×W×D)	120 x 130 x 18

Setting data record sheet

Pattern 1

Operation No.	Set time	Set details
1		
2		
3		
4		
5		
6		
7		
8		
9		
10		
11		
12		
13		
14		
15		
16		

Pattern 2

Operation No.	Set time	Set details
1		
2		
3		
4		
5		
6		
7		
8		
9		
10		
11		
12		
13		
14		
15		
16		

GB

Pattern 3

Operation No.	Set time	Set details
1		
2		
3		
4		
5		
6		
7		
8		
9		
10		
11		
12		
13		
14		
15		
16		

Pattern 4

Operation No.	Set time	Set details
1		
2		
3		
4		
5		
6		
7		
8		
9		
10		
11		
12		
13		
14		
15		
16		

Setting data record sheet

Pattern 5

Operation No.	Set time	Set details
1		
2		
3		
4		
5		
6		
7		
8		
9		
10		
11		
12		
13		
14		
15		
16		

Pattern 6

Operation No.	Set time	Set details
1		
2		
3		
4		
5		
6		
7		
8		
9		
10		
11		
12		
13		
14		
15		
16		

Pattern 7

Operation No.	Set time	Set details
1		
2		
3		
4		
5		
6		
7		
8		
9		
10		
11		
12		
13		
14		
15		
16		

Pattern 8

Operation No.	Set time	Set details
1		
2		
3		
4		
5		
6		
7		
8		
9		
10		
11		
12		
13		
14		
15		
16		

Setting data record sheet

Pattern 9

Operation No.	Set time	Set details
1		
2		
3		
4		
5		
6		
7		
8		
9		
10		
11		
12		
13		
14		
15		
16		



INHALT



Seite

1.	Vorsichtsmaßnahmen	36
2.	Bezeichnungen und Funktionen der einzelnen Bauteile	38
2-1.	Erscheinung	38
2-2.	Anzeigebereiche	39
2-3.	Bedienungsbereich	40
2-4.	Bildschirm-Konfiguration	41
3.	Beschreibung der Schemaeinstellung und Schemafunktion	42
3-1.	Beschreibung der Einstellung	42
3-2.	Schemafunktion	43
4.	Betriebsverfahren	44
4-1.	Normalbildschirm (KOLLEKTIV/GRUPPENSTATUS-ANZEIGEBILDSCHIRM)	44
4-1-1.	Gruppenwahl-Betrieb	44
4-1-2.	Ein/Aus-Betriebe (ON/OFF)	45
4-1-3.	Gemeinsames Beenden der Schemafunktionen für alle Gruppen	45
4-1-4.	Anzeige	45
4-2.	PROGRAMM-ÜBERWACHUNGS-Bildschirm (PROGRAM MONITOR)	45
4-3.	UHRZEIT/WOCHENTAG-EINSTELL-Bildschirm (TIME/DAY SETTING)	46
4-4.	PROGRAMM-EINSTELL-Bildschirm (PROGRAM SETTING)	46
4-4-1.	Einstellung des Programms	47
4-4-2.	Einstellung der Funktionsdetails	47
4-4-3.	Löschen einer Funktionseinstellung	48
4-4-4.	Kopieren der Details einer Mustereinstellung	48
4-5.	EINSTELL-Bildschirm für WÖCHENTLICHES PROGRAMM (WEEKLY PROGRAM SETTING)	48
4-5-1.	Einstellung des Funktionsmusters	49
5.	Fehlersuche	50
5-1.	Wenn "COLLECTIVE ON/OFF LAMP" und "FEHLERCODE" blinken	50
5-2.	Wenn nur der "Fehlercode" blinkt	50
6.	Externe Eingangs- und Ausgangsfunktionen	51
6-1.	Externer Eingang	51
6-1-1.	Notstopp-Eingangsmodus	51
6-1-2.	Ein/Aus-Pegelsignal-Eingangsmodus (ON/OFF)	51
6-1-3.	Ein/Aus (ON/OFF), Impuls-Eingangsmodus für zulässigen/unzulässigen Betrieb	52
6-2.	Externer Ausgang	52
7.	Anfangseinstellungen	53
7-1.	Wenn es sich bei dieser Fernbedienung um das Hauptsystem handelt	53
7-1-1.	Einstellung der Gruppe	55
7-1-2.	Einstellung der gekoppelten Geräte	58
7-1-3.	Kollektivlöschung	62
8.	Einstellung der Funktionen	62
8-1.	Einstellen mit der Haupt-Systemfernbedienung	62
8-2.	Verwendung der externen Eingangs-/Ausgangsfunktion	63
8-3.	Entaktivieren der lokalen Fernbedienungsfunktionen von dieser Fernbedienung aus	63
8-4.	Wenn der Betrieb mit der lokalen Fernbedienung und der Systemfernbedienung unzulässig ist	63
8-5.	Änderung der Temperaturanzeige auf "Fahrenheit-Anzeige"	63
9.	Systembeschränkungen	64
10.	Technische Daten	65
10-1.	Produkt-Funktionen	65
10-2.	Hauptdaten	66

1. Vorsichtsmaßnahmen

■ Bevor Sie starten, sollten Sie sich immer diese "Vorsichtsmaßnahmen" durchlesen und die Installation entsprechend richtig durchführen.

■ Die beiden nachfolgend aufgeführten Symbole dienen zur Bezeichnung der Gefahren, die bei einer falschen Handhabung des Gerätes verursacht werden können. Desweiteren zeigen die Symbole den jeweiligen Gefahrengrad an.

 WARUNG	Dieses Symbol bezeichnet, welche Gegebenheiten bei einem Missbrauch zu schweren oder tödlichen Verletzungen führen können.
 VORSICHT	Dieses Symbol bezeichnet, welche Gegebenheiten bei einem Missbrauch zu Sachbeschädigungen oder Personenschäden führen können.

■ Bewahren Sie dieses Handbuch nach dem Durchlesen zusammen mit dem Installationshandbuch an einem sicheren Ort auf, um später im Bedarfsfall jederzeit nachschlagen zu können.
Bei einem Benutzerwechsel muss sowohl dieses Handbuch als auch das Installationshandbuch dem neuen Benutzer ausgehändigt werden.