

Thermometers and thermostats with 1 probe and 1 relay: AKO-140XX, AKO-141XX.



GENERAL DESCRIPTION:

Electronic thermometers and thermostats for panel, suitable for displaying, controlling and adjusting cold (with manual and automatic programmable defrosting) or heat generators.

VERSIONS:

MODEL	FUNCTION	FASTENING	RELAY	POWER SUPPLY 50/60Hz
AKO-14012	Thermometer	For panel	-	12/24 V \approx \pm 10% 76/55 mA,
AKO-14023	Thermometer	For panel	-	230 V \sim \pm 10% 6,7 mA,
AKO-14031	Cal. thermometer	For panel	-	230 V \sim \pm 10% 6,7 mA,
AKO-14112	Thermostat	For panel	8A, $\cos \varphi = 1$	12/24 V \approx \pm 10% 110/71 mA,
AKO-14123	Thermostat	For panel	8A, $\cos \varphi = 1$	230 V \sim \pm 10% 8,2 mA,

The AKO-14031 model has a probe calibration feature.

TECHNICAL DATA:

Temperature range: -50°C to 99°C
 NTC probe input: Ref. AKO-149XX
 Controller accuracy: \pm 1°C
 Probe tolerance at 25°C: \pm 0,4°C
 Working ambient temperature: 5°C to 50°C
 Storage ambient temperature: -30°C to 70°C

Control device classification:
 -with independent mounting
 -with characteristic of automatic operation action, Type 1.B
 -to be used in clean situation
 -logical medium (software) class A

INSTALLATION:

Controller:

The thermometer or thermostat must be installed in a place protected from vibrations, water and corrosive gases, and where the ambient temperature does not surpass the values specified in the technical data.
 For the equipment for panel to be suitable having IP65 protection the gasket should be installed properly between the apparatus and the perimeter of the panel cut-out where it is to be fitted.

Probe:

To give a correct reading, the probe has to be installed in a place without heat influences other than the temperature that is to be measured or controlled.

Connection:

See diagram in the unit rating plate.
 The probe and its lead should **NEVER** be installed in a conduct next to power, control or power supply wiring systems.
 The power supply circuit should be connected with a switch for disconnection of minimum 2A, 230V, located near the unit. The connection cables should be H05VV-F 2x0,5mm² or H05V-K 1x0,5mm² type, to posterior part of the unit.
 Section of connecting wires for relays contacts must be between 1mm² and 2,5 mm².

Fastening:

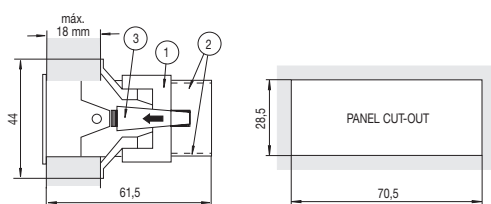

To fix the unit, place the fasteners 1 via the sliders 2 as shown in the figure. Move the fasteners in the direction of the arrow. Press tab 3 to move the fasteners in the opposite direction of the arrow.

FRONT PANEL FUNCTIONS:

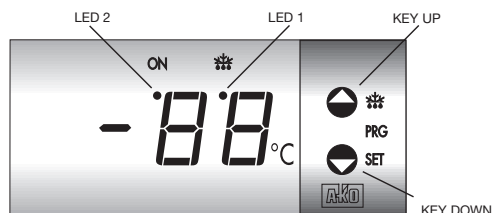

Functions for thermostats:

- Press for 5 seconds to activate manual defrost of the programmed duration. In programming, it increases the displayed value.
- Press for 5 seconds to displays the Set Point temperature. In programming it reduces the displayed value.

Indicator LEDs:

LED 1: Defrost activated indicator.
 LED 2: Relay ON indicator.
 LED 2 flashing: Programming phase.

TEMPERATURE ADJUSTMENT:

The factory SET POINT value for temperature is 0°C.

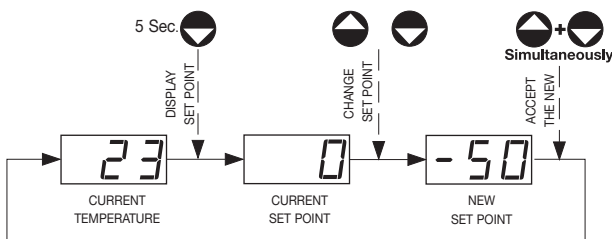

-Press the \uparrow key for 5 seconds. The current SET POINT value will be displayed and LED "2" will flash.

-Press the \uparrow or \downarrow keys to adjust the SET POINT to the required value.

-Press the \uparrow + \downarrow keys simultaneously to set the new value. The display will revert to temperature indication status and the LED "2" stop flashing.

NOTE: If no key is pressed for 25 seconds in either of the previous steps the controller will automatically revert to the temperature indication status without modifying the SET POINT value.

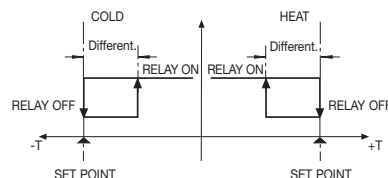

Adjusting the calibration in the AKO-14031 Thermometer

Press both keys simultaneously for 10 seconds to display the calibration value (0°C by default). Each press of the keys \uparrow or \downarrow change 1°C the displaying temperature between -20°C and +20°C. To accept the value press both keys again simultaneously. If no key is pressed for 25 seconds in either of the previous steps the thermometer will revert to temperature indication status without modifying the calibration value.

PROGRAMMING:

The parameters may only be programmed or modified by staff that are fully acquainted with how the machine operates and the characteristics of the unit where it is to be applied.

Programming parameters:

Level 1:

- Press the \uparrow + \downarrow keys simultaneously for 10 seconds. LED "2" will flash and the first parameter "C0" will appear on the display.
- Press the \downarrow key to access the next parameter and the \uparrow key to go back to the previous one.
- In the last parameter, EP, pressing the \uparrow + \downarrow keys simultaneously the controller will revert to temperature indication status and the LED "2" stop flashing.

Level 2:

-To display the current value of any parameter, go to the required parameter and press the \uparrow + \downarrow keys simultaneously. Once it is on screen, press the \uparrow or \downarrow keys to modify it. Press the \uparrow + \downarrow keys simultaneously to set the new value. The programming will revert to level 1 (parameters).

NOTE: If no key is pressed for 25 seconds in either of the previous steps the controller will automatically revert to the temperature indication status without modifying the parameter value.

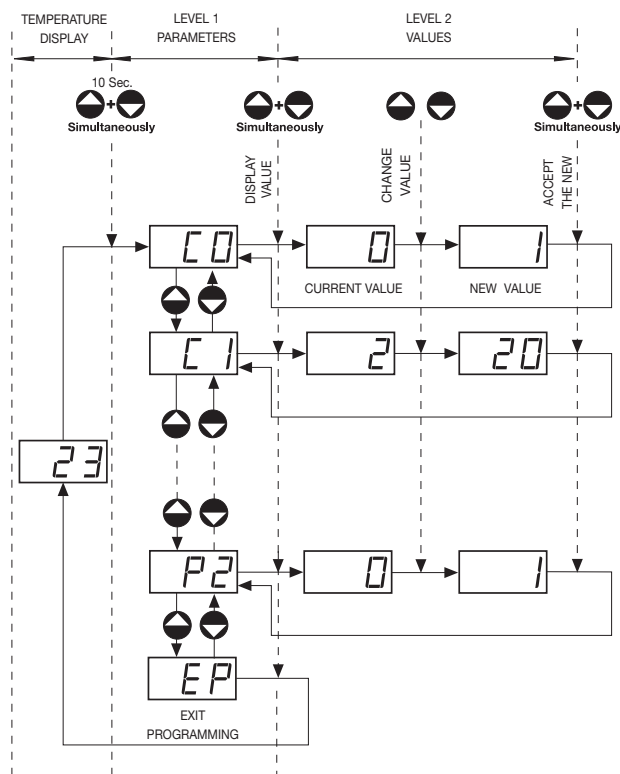

DESCRIPTION OF THE PARAMETERS:

See TEMPERATURE ADJUSTMENT (Set Point) for programming it.

The values of the DEF column are factory-set.

PARAMETER	DESCRIPTION	RANGE		VALUE DEF.
		MIN.	MAX.	
C0	Probe calibration (Offset) Temperature Increase / Decrease added to the temperature detected by the thermostat to adjust the probe to the real value.	-20°C	+20°C	0°C
C1	Differential (Hysteresis) Temperature increase above or below the temperature indicated by the SET POINT for operation relay.	1°C	20°C	2°C
C2	Maximum SET POINT limiter The SET POINT cannot be set above this value, with the AH temperature alarm activated if the temperature is above C2.	xx°C	99°C	99°C
C3	Minimum SET POINT limiter The SET POINT cannot be set below this value, with the AL temperature alarm activated if the temperature is below C3.	-50°C	xx°C	-50°C
C4	Type of delay for compressor protection 0=(off/on): Delays relay connection as of last deactivation. 1=(on): Delays relay connection once the temperature has it activated.	0	1	0
C5	Protection delay time Number value of the option selected in parameter C4	0 min.	99 min.	0 min.

C6	Relay status in case of probe failure Selection 0 Sequence ON/OFF equal to the mean of times of the last 24 hours. It carries out defrosts, observing the programmed time. Selection 1 Operating sequence (OFF/ON) as programmed in C7 and C8.	0	1	0
C7	Time relay is ON in case of probe failure Period for which the controller relay stays ON, (e.g. compressor on). With C7=0 and C8#0 programmed, the relay will always be OFF.	0 min.	99 min.	10 min.
C8	Time relay is OFF in case of probe failure Period for which the controller relay stays OFF (e.g. compressor off). With C8=0 and C7#0 programmed, the relay will always be ON.	0 min.	99 min.	5 min.
d0	Defrost frequency (in cold operation) Time elapsed between 2 defrost starts-ups.	0 h	99 h	1 h
d1	Defrost duration (in cold operation) During this time the defrost indicator LED will come on and the relay output will be off (OFF: compressor)	0 min.	99 min.	0 min
d2	Type of message during defrost 0=The controller will display the real temperature 1=The controller will display the defrost start temperature 2=The controller will display the dF message	0	2	2
d3	Maximum added message time after defrost Once this delay is over the controller will revert to temperature indication status.	0 min	99 min	5 min
P0	Type of operation (cold/heat) Selects thermostat operation for cold or heat applications Selection 0=Cold Differential above the SET POINT Selection 1=Heat Differential below the SET POINT	0	1	0
P1	Delay all functions Delays all functions when the apparatus is powered up.	0 min.	99 min	0 min
P2	Block programmed parameters 1=yes, option that blocks the possibility of modifying the programmed parameters. 0=no, option to unblock the previous one.	0=no.	1=yes	0=no
P3	Revert to initial parameters 1=yes, configures all the parameters of the unit with the values of the DEF column of these instructions and exit from programming.	-	1	-
EP	Exit programming			

NOTE: When time parameters are modified, the new values will be applied once the cycle in progress has concluded. If you wish it to be done immediately, switch the controller off and on again. The times programmed will work properly 1 minute at most after the controller is switched back on.

OPERATING MESSAGES:

DISPLAY	DESCRIPTION
dF	Defrost activated.
AL	Temperature below the minimum limiter of the Set-Point (C3)
AH	Temperature above the maximum limiter of the Set-Point (C2) or else between 99°C < temp. < 110°C
E1	Probe short-circuited, circuit opened, >110°C or <-50°C
EE	Memory error

MAINTENANCE:

Clean the surface of the controller with a soft cloth and soap and water. Do not use abrasive detergents, petrol, alcohol or solvents.

WARNINGS:

The use of the unit different to the manufacturer's instructions voids the safety qualification.

Use only NTC type AKO-supplied probes for the device to work properly.

Between -40°C and +20°C, when probe is extended with minimum 0,5 mm² up to 1000 m cable, deviation will be of 0,25°C.