



# Centralized On-Off Remote Controller MAC-821SC-E



[FOR INSTALLER]

## INSTALLATION MANUAL

[FÜR INSTALLATEUR]

## INSTALLATIONSHANDBUCH

[POUR L'INSTALLATEUR]

## MANUEL D'INSTALLATION

[VOOR DE INSTALLATEUR]

## INSTALLATIEHANDLEIDING

[PARA EL INSTALADOR]

## MANUAL DE INSTALACIÓN

[PER L'INSTALLATORE]

## MANUALE DI INSTALLAZIONE

[ΓΙΑ ΑΥΤΟΝ ΠΟΥ ΚΑΝΕΙ ΤΗΝ ΕΓΚΑΤΑΣΤΑΣΗ]

## ΕΓΧΕΙΡΙΔΙΟ ΟΔΗΓΙΩΝ ΕΓΚΑΤΑΣΤΑΣΗΣ

[PARA O INSTALADOR]

## MANUAL DE INSTALAÇÃO

[TIL INSTALLATØREN]

## INSTALLATIONSMANUAL

[FÖR INSTALLATÖREN]

## INSTALLATIONSMANUAL

[MONTÖR İÇİN]

## MONTAJ ELKİTABI

[ДЛЯ УСТАНОВИТЕЛЯ]

## РУКОВОДСТВО ПО УСТАНОВКЕ

[安装人员适用]

## 安装说明书

[安裝人員適用]

## 安裝說明書

English

Deutsch

Français

Nederlands

Español

Italiano

Ελληνικά

Português

Dansk

Svenska

Türkçe

Русский

简体中文

繁體中文

## Caution

To use this centralized controller, you must have a MA & Contact Terminal Interface (MAC-397IF-E, sold separately) for each air conditioner unit.

## Contents

1. Safety Instructions .....	2
2. Accessory .....	3
3. Mounting the Centralized Controller/Direct Wiring .....	6
4. Mounting the Centralized Controller .....	8
5. Test Run .....	9
6. Room Name Display .....	9
7. Specifications .....	9

## 1. Safety Instructions

- Read all Safety Instructions before using this device.
- This manual contains important safety information. Be sure to comply with all instructions.
- After installing the controller, provide this Installation Manual to the user.  
Instruct users to store their room air conditioner Instruction Manual and Warranty in a safe location.

### Warning

(Improper handling may have serious consequences, including injury or death.)

■ **Users should not install the centralized controller themselves.**

Improper installation may result in fire, electric shock, or damage/water leaks if the centralized controller falls. Consult the retailer or specialty store where you purchased the unit for referral to an installer.

■ **The centralized controller should be securely installed in accordance with the enclosed Installation Instructions.**

Improper installation may result in fire, electric shock, or damage/water leaks if the centralized controller falls.

■ **The unit should be mounted in a location that can support its weight.**

If installed in an area that cannot support the unit, the centralized controller could fall and cause damage.

■ **Securely attach the electrical component cover to the centralized controller.**

If the electrical component cover of the centralized controller is not securely attached, dust or water penetration could occur, resulting in a fire or electric shock.

■ **Mitsubishi components or other designated components should be used for installation.**

Improper installation may result in fire, electric shock, or damage/water leaks if the centralized controller falls.

■ **When performing electrical work, adhere to the Technical Standards Regarding Electrical Equipment and the Interior Wiring Standards, follow the instructions provided in the Instruction Manual, and be sure to use a dedicated circuit.**

Inadequate circuit capacity or improper installation could result in a fire or electric shock.

## 2. Accessory

Before installing the unit, make sure that you have all the necessary parts.

①	Centralized controller Ⓐ Cover Remove the cover with a flathead screwdriver. Ⓑ Screw	1
②	Base plate	1
③	Switch box	1
④	Room name stickers	1
⑤	Rubber seal (large)	2
⑥	Rubber seal (small)	1
⑦	Sealing material (adhesive)	4
⑧	Mounting screw M4 × 30	2

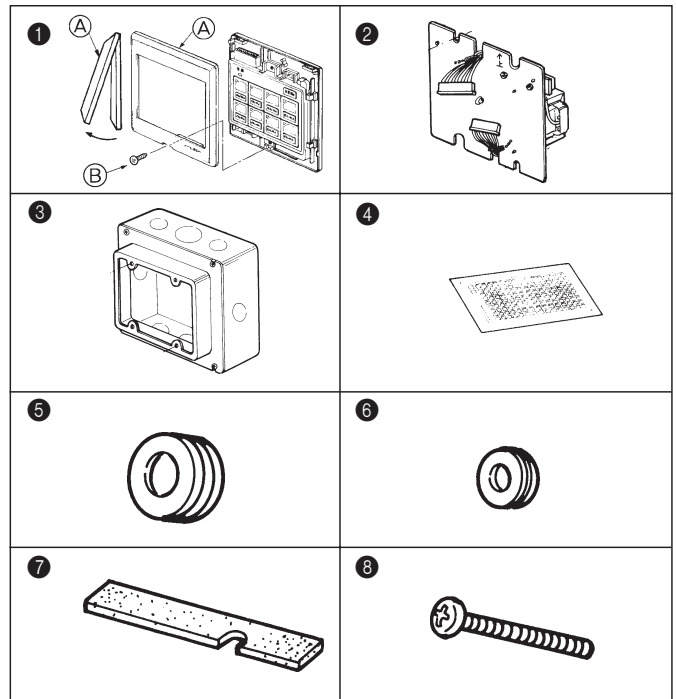

### ■ Items to Prepare at the Installation Site

Ⓐ	MA & Contact terminal interface (MAC-397IF-E)	One per air conditioner
Ⓑ	Power supply wire (2-core + ground) 1.5 mm <sup>2</sup> , in conformity with Design 245 IEC 57.	1
Ⓒ	Connection wire Wire specification CVV (3-core) 0.5 mm <sup>2</sup> or equivalent * CVV is a control cable which is sheathed in polyvinyl chloride with polyvinyl insulated wires inside.	One per air conditioner
Ⓓ	Ring tongue terminal for M4	1
Ⓔ	PG connection	1

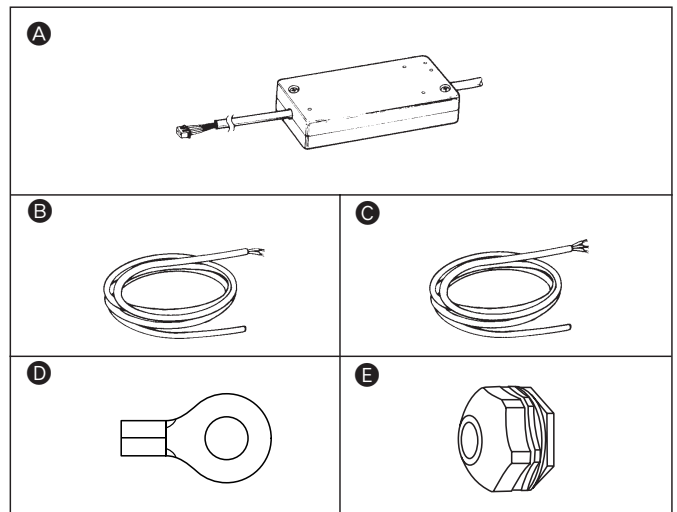

### ■ Mounting Wall

This centralized controller can be mounted on a wall with a thickness of 6–30 mm.

Since the maximum wall thickness for the centralized controller's mounting screw M4 × 30 ⑧ is 17 mm, use screws of the appropriate length for the wall thickness if the wall is between 17 mm and 30 mm thick.

(The best length for an M4 mounting screw is the wall thickness plus 13 mm.)

## 2-1. Connection Requirements

The MA & Contact terminal interface (MAC-397IF-E) is necessary to connect MAC-821SC-E with RAC.

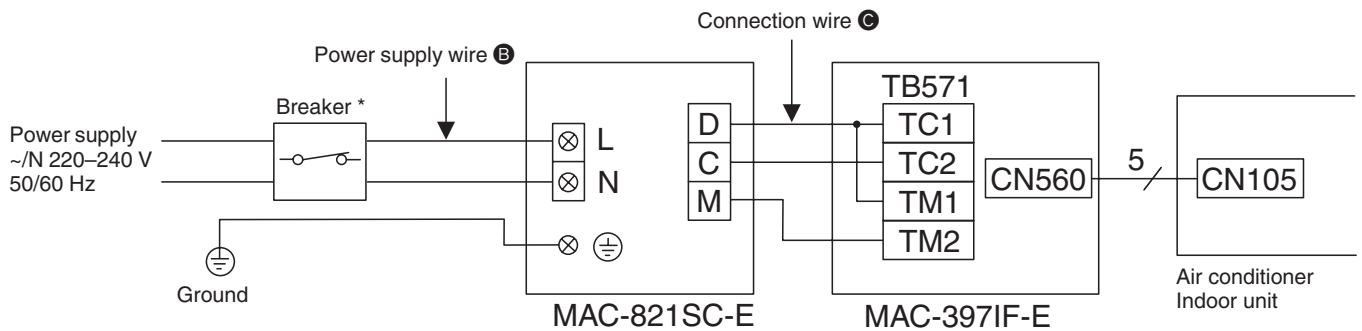

Breaker capacity	Connect to the supply terminals and leave a contact separation of at least 3 mm at each pole to disconnect the source power pole. (When the power switch is shut off, it must disconnect all poles.)
10 A	

## 2-2. Selecting an Installation Site

- The centralized controller ❶ is an exposed, wall-mounted model.  
Install the unit in a dry location.
- For information on selecting a mounting wall, see the “Mounting Wall” in section 2.

### ■ Switch Box

The centralized controller power and connection wiring is generally direct wired.

The switch box ❸ supplied (with switch box covers for 2 units) should therefore be used for installing the centralized controller.

## 2-3. Electrical Work

- Use 1.5 mm<sup>2</sup> power supply wire (2-core + ground).
- For the connection wire ❷, use a control cable CVV (0.5 mm<sup>2</sup> 3-core) or equivalent product.  
CVV is a control cable which is sheathed in polyvinyl chloride with polyvinyl insulated wires inside.
- Complete the power supply wire and connection wire work before mounting the centralized controller.
- The electrical work should be performed in accordance with the Technical Standards Regarding Electrical Equipment and the Interior Wiring Standards.

## 2-4. Assigning Air Conditioner Device Numbers

- The numbers (1–8) displayed on the control panel of the centralized controller ❶ correspond to the numbers of each connected air conditioner (device number).
- Assign air conditioner device numbers that correspond to the numbers shown on the control panel based on the structure of the building or the layout of the rooms in which the air conditioners are installed.

## 2-5. Sample of Configuration

This figure shows a sample 4-unit configuration.

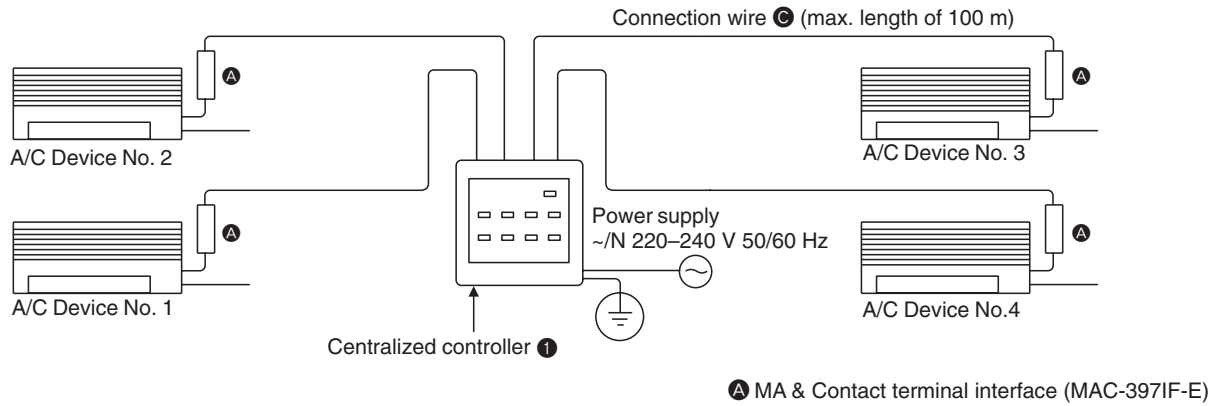

## 2-6. Mounting Diagram

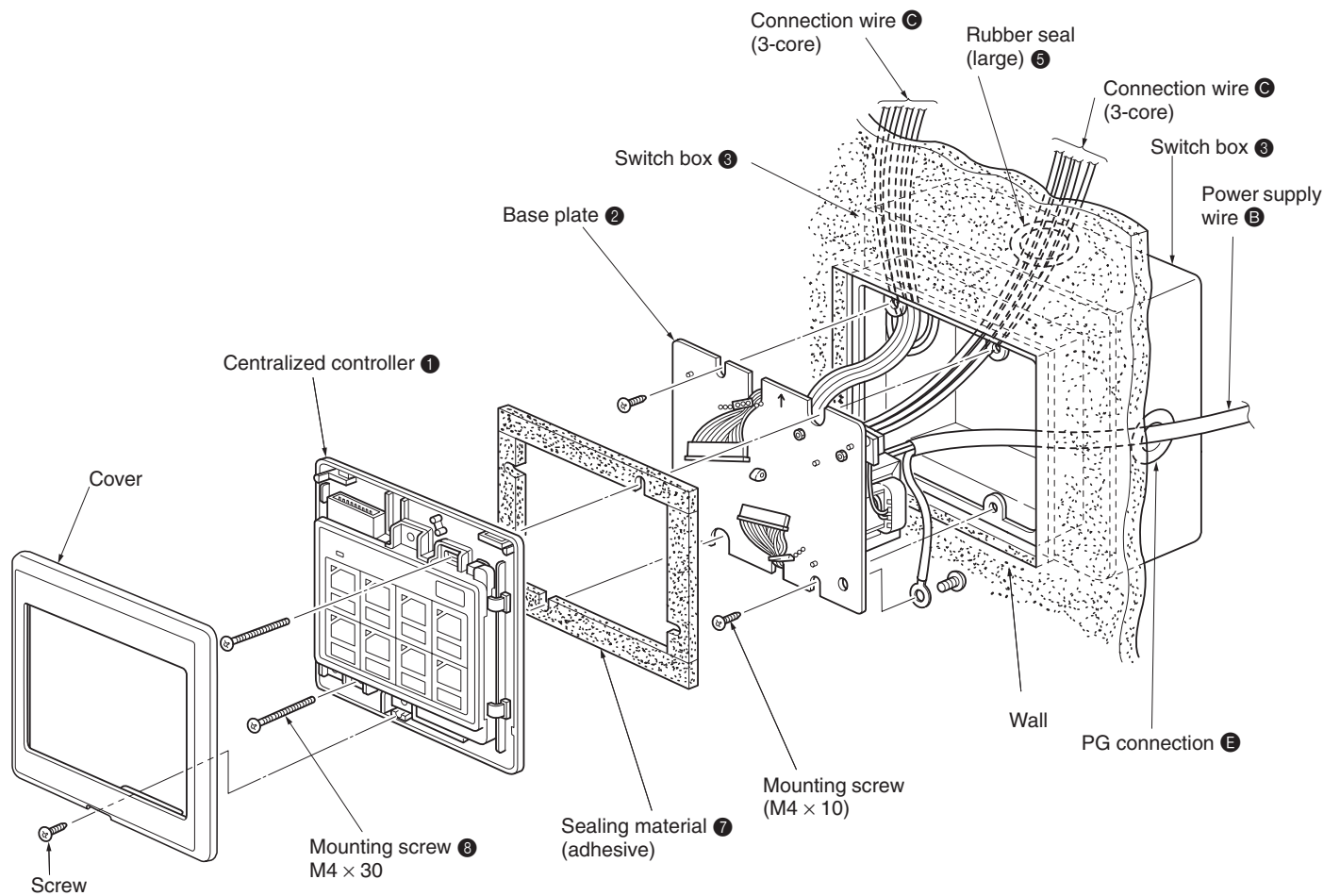

# 3. Mounting the Centralized Controller/Direct Wiring

## 3-1. Mounting Preparations

**1** Remove 2 screws, and remove the base plate ② from the switch box ③. Set the 2 screws aside, as they will be used in the section on “4-1. Mounting the Base Plate” under “Mounting the Centralized Controller”.

**2** Insert the switch box ③ into the wall. Size the hole in the wall to ensure that there is no gap between the switch box ③ and the wall surface. Use the switch box ③ wall installation dimensions and opening dimensions shown in the figure below.

**3** Feed the power supply wire ①, connection wire ②, and ground wire from inside of the wall, and pull them through the switch box ③ into the room about 150 mm. In addition, when not using a conduit for a connection wire ②, be sure to install a rubber seal (large) ⑤ or rubber seal (small) ⑥ into the hole in the switch box ③ before feeding the connection wire ② through the hole. Use the PG connection ③ prepared at the installation site to secure the power supply wire ① in the hole in the switch box ③.

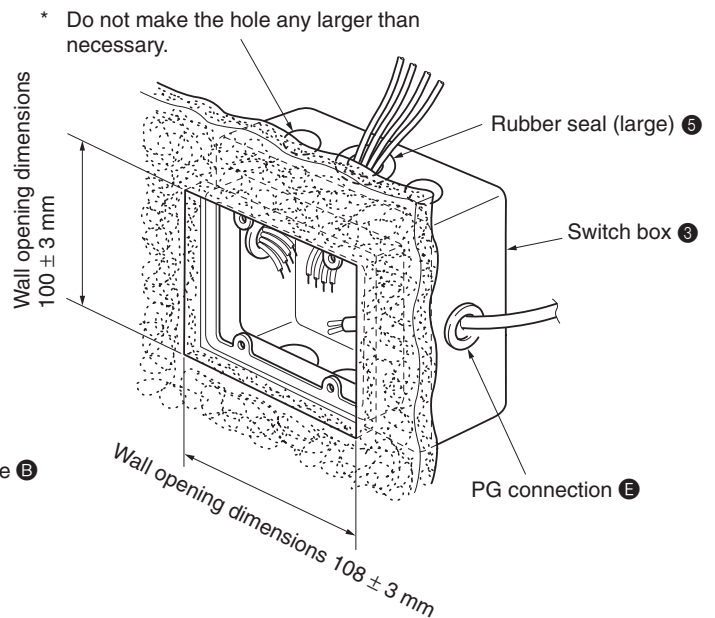
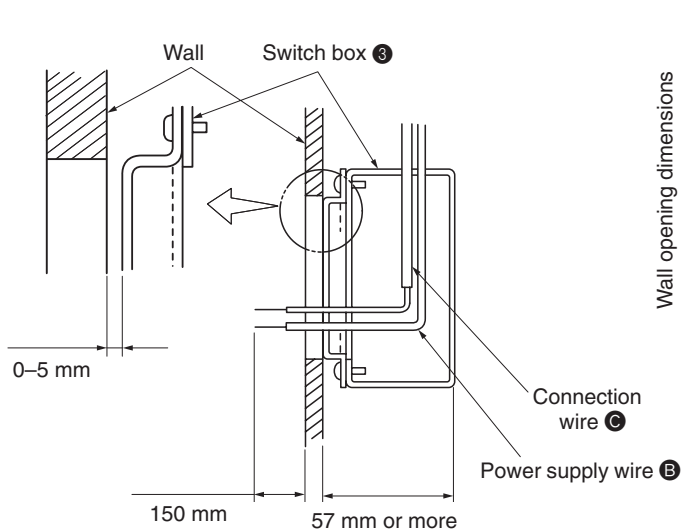
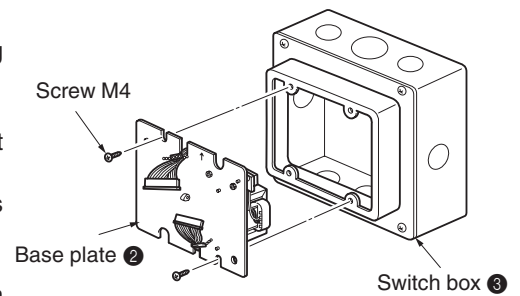

**4** After the screws have been removed from the cover of the centralized controller ①, remove the cover using a flathead screwdriver.

## 3-2. Connecting the Connection Wire

- 1 Connect the power supply wire (2-core + ground) **B** to the power terminal. After they are connected, check that the wires cannot be easily pulled off.

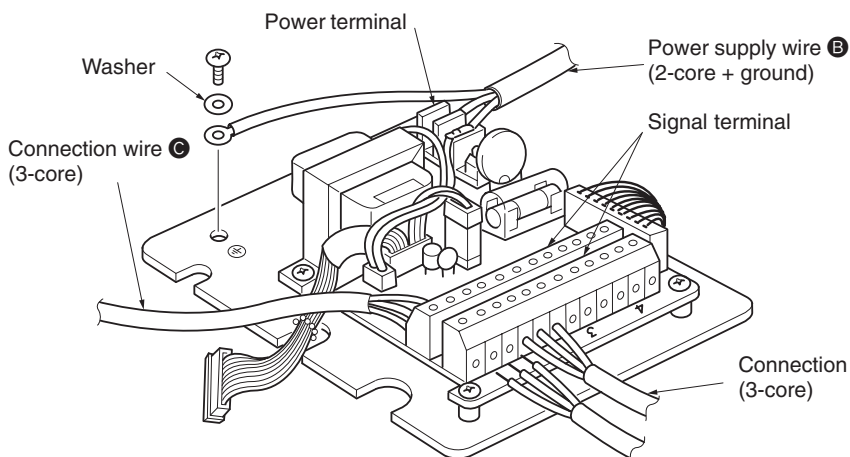

### Work on Power Supply wire End

- Be sure to use 1.5 mm<sup>2</sup> power supply wire **B** (2-core + ground).
- The work on power supply wire end should be performed as shown in the figure below.

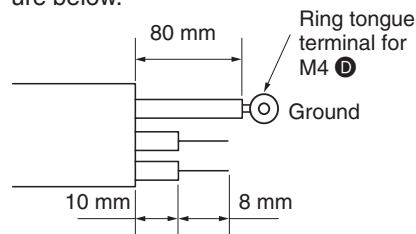

- 2 Mount the ground wire using the ground wire mounting screws.

- 3 Connect the connection wire (3-core) **C** to the MA & Contact terminal interface (MAC-397IF-E) **A**, (sold separately) corresponding to the air conditioner device number of each unit on the signal terminal.

- One signal terminal can be used for connecting 4 rooms.

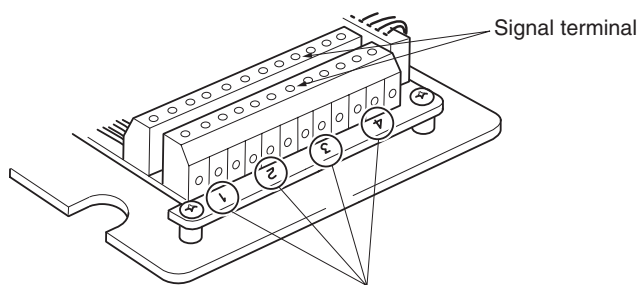

\* Connect the devices corresponding to their display number on the control panel.

### Work on Connection Wire End

Note: Centralized controller side

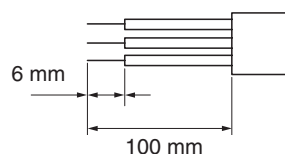

- Connect the centralized controller to the adapters as shown below.

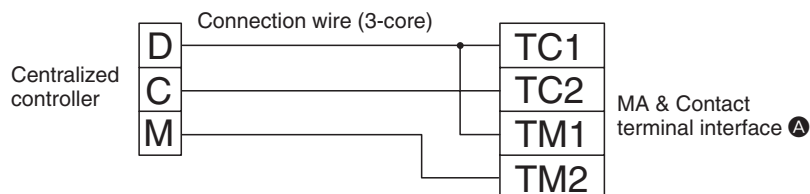

## 4. Mounting the Centralized Controller

### 4-1. Mounting the Base Plate

Insert the base plate ② into the switch box ③, and remount it using the screws removed in the “3-1 Mounting Preparations”. Be sure to mount the base plate ② so the up arrow is facing upward.

Also, be careful not to damage the wires by getting them caught between plate and the switch box ③.

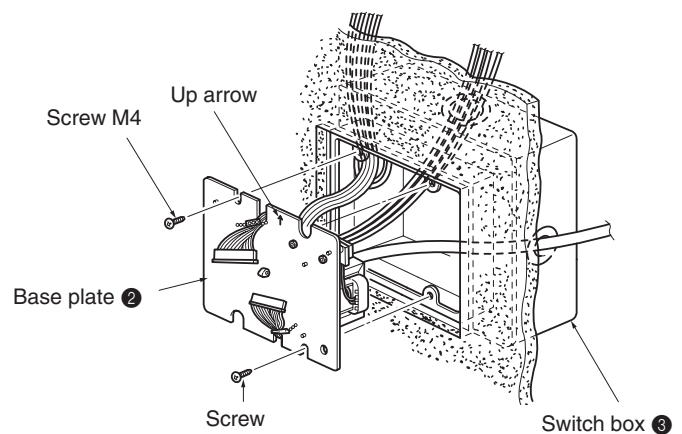

### 4-2. Mounting the Centralized controller

**1** Before mounting the unit, apply the supplied sealing materials ⑦ to the base plate ②, and fill in the space between the switch box ③ and the hole in the wall (a gap here could result in dew condensation).

Cut the sealing material ⑦ to a length such that it can be wrapped around the hole in the wall based on the fixed position.

**2** Connect the connection cord from the base plate ② through the slot in the centralized controller.

**3** Mount the centralized controller to the base plate ② using the supplied mounting screw ⑧. Be careful not to damage the connection wires by getting them caught in the walling materials.

**4** Using the supplied screw, attach the cover to the centralized controller.

**5** To attach the cover to the centralized controller, fit the tabs along the top of the cover into the holes in the centralized controller and then push the lower portion of the cover into place.

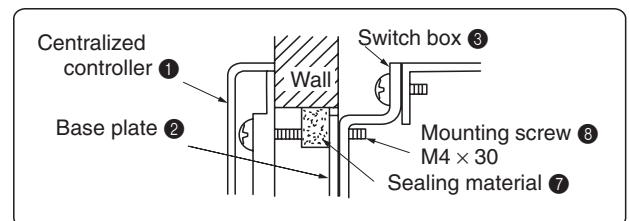

#### ⚠ Caution

Be sure not to tighten the mounting screw ⑧ too tight.

Doing so may disfigure the centralized controller and prevent the cover from closing securely.

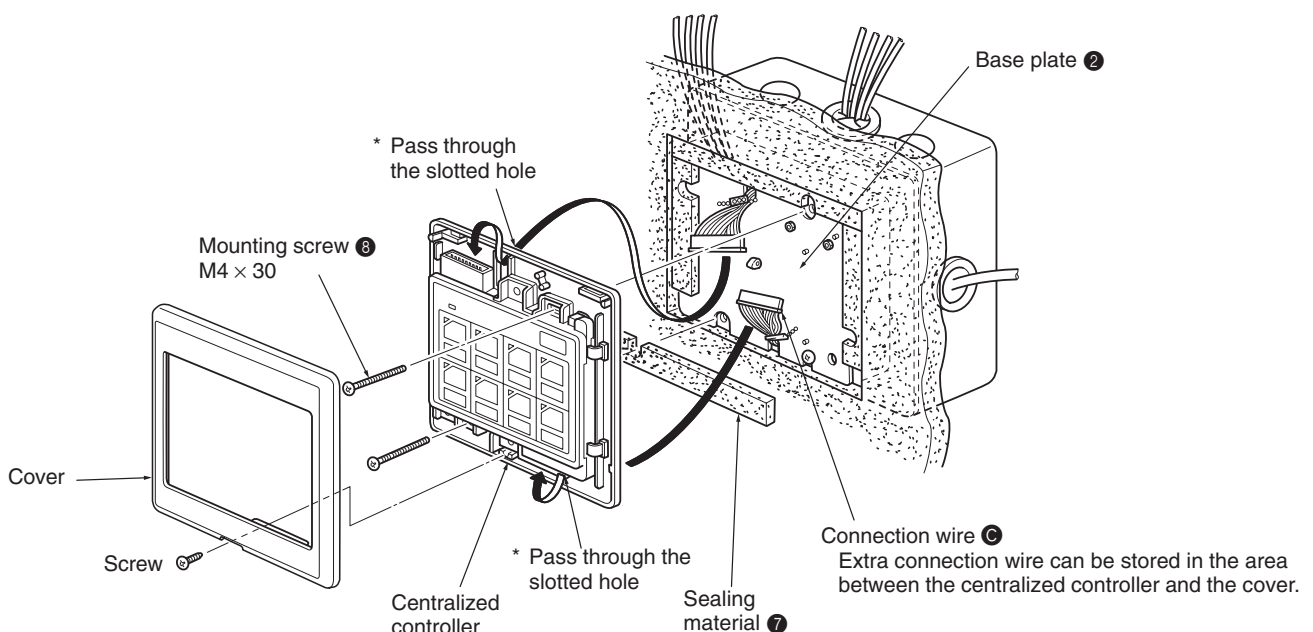



## 5. Test Run

A test run should be performed after the centralized controller and the MA & Contact terminal interface (MAC-397IF-E) have all been installed.

- 1 Turn the power switch on each air conditioner to ON.
- 2 Press the ON/OFF button on the wireless remote controller for each air conditioner to make sure the air conditioner turns on, and then press the button again to turn each unit off.
- 3 Supply power (AC 220–240 V) to the centralized controller.
- 4 Press the ON/OFF button on the upper part of the control panel of the centralized controller, and confirm that the (green) operation indicator lamp for that device number comes on. Also confirm that the corresponding air conditioner has turned on (the operation indicator lamp will not come on if the air conditioner is not connected).
- 5 Press the ON/OFF button again, and confirm that the operation indicator lamp goes out and that the air conditioner unit turns off.
- 6 Repeat steps 4 and 5 again for each device number.
- 7 Press the All OFF button, and confirm that all the (green) operation indicator lamps go out and that all the air conditioners turn off.

## 6. Room Name Display

Select the appropriate stickers from the room name stickers ④ supplied, and affix them to the display section of the panel.

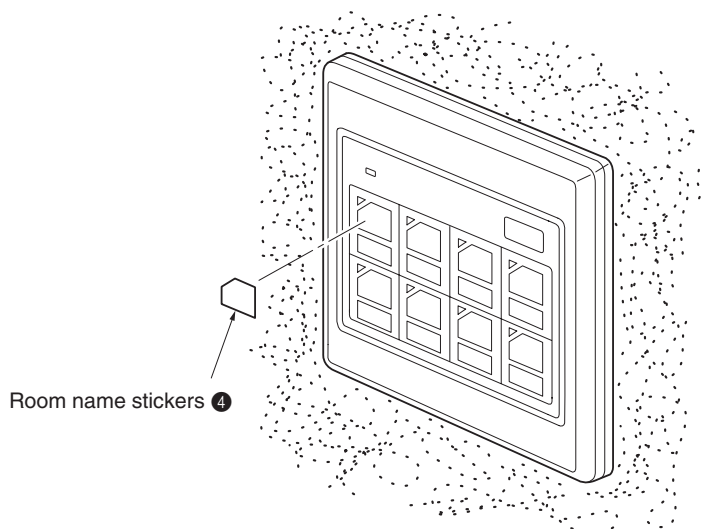

## 7. Specifications

Model	MAC-821SC-E
No. of controlled air conditioners	8 units
Power	~N, 220–240 V, 50/60 Hz
Power consumption	4 W
Current	0.02 A
Ambient temperature	0–40°C
Dimensions (H × W × D)	120 × 120 × 15
Weight	910 g

This product is designed and intended for use in the residential, commercial and light-industrial environment.

The product at hand is based on the following EU regulations:

- Low Voltage Directive 73/23/EEC
- Electromagnetic Compatibility Directive 89/336/EEC

 **MITSUBISHI ELECTRIC CORPORATION**  
HEAD OFFICE: MITSUBISHI DENKI BLDG., 2-2-3, MARUNOUCHI, CHIYODA-KU, TOKYO 100-8310, JAPAN

---