

Cylinder unit

Гидромодуль с накопительным баком ГВС

EHST20 series

EHPT20 series

ERST20 series

INSTALLATION MANUAL

For safe and correct use, read this manual and the outdoor unit installation manual thoroughly before installing the cylinder unit. English is the original language. The other languages versions are translation of the original.

FOR INSTALLER

INSTALLATIONSHANDBUCH

Aus Sicherheitsgründen und zur richtigen Verwendung vor der Installation des Hydraulikmoduls inkl. Speicher die vorliegende Bedienungsanleitung und die Installationsanleitung der Außeneinheit gründlich durchlesen. Die Originalsprache ist Englisch. Die anderen Sprachversionen sind vom Original übersetzt.

FÜR INSTALLATEURE

MANUEL D'INSTALLATION

Pour une utilisation correcte et sûre, lisez soigneusement ce manuel et le manuel d'installation de l'unité extérieure avant d'installer l'ECODAN hydrobox duo. L'anglais est la langue originale. Les versions fournies dans d'autres langues sont des traductions de l'original.

POUR L'INSTALLATEUR

INSTALLATIEHANDLEIDING

Lees voor een veilig en juist gebruik deze handleiding en de installatiehandleiding van de buiten-unit aandachtig door voordat u met de installatie van de cilinder begint. Engels is de oorspronkelijke taal. De andere taalversies zijn vertalingen van het origineel.

VOOR DE INSTALLATEUR

MANUAL DE INSTALACIÓN

Para un uso correcto y seguro, lea detalladamente este manual y el manual de instalación de la unidad exterior antes de instalar el hydrobox duo. El idioma original del documento es el inglés. Las versiones en los demás idiomas son traducciones del original.

PARA EL INSTALADOR

MANUALE DI INSTALLAZIONE

Per un utilizzo sicuro e corretto, prima di installare l'hydrotank leggere attentamente questo manuale e quello di installazione dell'unità esterna. Il testo originale è redatto in lingua inglese. Le altre versioni linguistiche rappresentano traduzioni dell'originale.

PER L'INSTALLATORE

MANUAL DE INSTALAÇÃO

Para uma utilização segura e correcta, leia este manual e o manual de instalação da unidade exterior antes de instalar o cilindro. O idioma original é o inglês. As versões em outros idiomas são traduções do idioma original.

PARA O INSTALADOR

INSTALLATIONSMANUAL

Af hensyn til sikker og korrekt brug skal denne vejledning og vejledningen til udendørsenheden installation læses omhyggeligt, inden tank modulet (unit) installeres. Engelsk er det oprindelige sprog. De andre sprogversioner er oversættelser af originalen.

TIL INSTALLATØREN

INSTALLATIONSMANUAL

För säker och korrekt användning, läs denna manual och utomhusenhetens installationsmanual innan du installerar cylindertanken. Engelska är originalspråket. De övriga språkversionerna är översättningar av originalet.

FÖR INSTALLATÖREN

INSTALLERINGSHÅNDBOK

For å sikre en trygg og riktig bruk skal du lese denne håndboken og installeringshåndboken for utendørsenheten grundig før du monterer sylinderenheten. Engelsk er originalspråket. De andre språkversjonene er oversettelser av originalen.

FOR MONTØREN

ASENNUSOPAS

Lue turvallista ja asianmukaista käyttöä varten tämä opas ja ulkoyksikkö asennusopas huolellisesti ennen varaajayksikön asentamista. Alkuperäiskieli on englanti. Muut kieliversiot ovat alkuperäisen käännöksiä.

ASENTAJALLE

РУКОВОДСТВО ПО УСТАНОВКЕ

Для безопасного и правильного использования внимательно прочитайте данное руководство и руководство по установке наружного блока перед установкой гидромодуля. Оригинальная версия на английском языке, другие - перевод с оригинала.

ДЛЯ МОНТАЖНИКОВ

PŘÍRUČKA PRO INSTALACI

Z bezpečnostních důvodů a pro správné použití zásobníkového modulu si před jeho instalací důkladně prostudujte Návod k obsluze a také Příručku pro instalaci venkovní jednotky. Jazyk originálu je angličtina. Jiné jazykové verze jsou překlady z originálu.

PRO TECHNIKY PROVÁDĚJÍCÍ INSTALACI

INSTRUKCJA MONTAŻU

Należy dokładnie zapoznać się z niniejszą instrukcją obsługi i instrukcją montażu jednostki zewnętrznej, aby następnie bezpiecznie i z dobrym skutkiem użytkować moduł wewnętrzny z wbudowanym zasobnikiem CWU. Oryginal dokumentu jest dostępny w języku angielskim. Inne wersje językowe są tłumaczeniami oryginału.

DLA INSTALATORA

РЪКОВОДСТВО ЗА МОНТАЖ

С оглед на безопасността и за правилна употреба на Hydrobox включително Cylinder unit прочетете внимателно – преди монтажа – настоящото ръководство за потребителя и ръководството за монтаж на външното тяло. Оригиналният език е английски. Другите езикови варианти са превод от оригинала.

ЗА ИНСТАЛАТОРИ**English (EN)****Deutsch (DE)****Français (FR)****Nederlands (NL)****Español (ES)****Italiano (IT)****Português (PT)****Dansk (DA)****Svenska (SV)****Norsk (NO)****Suomi (FI)****Русский (RU)****Český (CZ)****Polski (PL)****Български (BG)**

Contents

1. Safety Notices.....	2
2. Introduction.....	2
3. Technical Information	3
4. Installation.....	11
4.1 Location.....	11
4.2 Water Quality and System Preparation	12
4.3 Water Pipe Work.....	13
4.4 Safety Device Discharge Arrangements (G3)	17
4.5 Electrical Connection	18
5. System Set Up	22
5.1 DIP Switch Functions	22
5.2 Connecting inputs/outputs	23
5.3 Wiring for 2-zone temperature control	24
5.4 2-zone valve ON/OFF control	25
5.5 Indoor unit only operation (during installation work)	25
5.6 Smart grid ready	25
5.7 Main remote controller Options.....	26
5.8 Using SD memory card	28
5.9 Main remote controller	29
6. Commissioning.....	36
7. Service and Maintenance.....	37
8. Supplementary information.....	42

EN

■ Heat pumps certification

The mark “NF heat pumps” is an independent certification program proving that heat pumps’ performances and production quality of the factory are conformed with the certification reference NF-414. The combinations of indoor units and outdoor units, and their applications allowed to use the NF PAC mark can be consulted on the website www.marque-nf.com

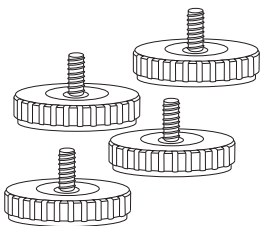
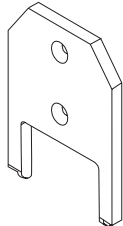
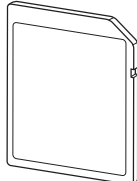
Accessories (Included)		
Adjustable feet	Immersion heater boss tool EH*T20*-MHC* model only	SD memory card
		
4	1	1

Abbreviations and glossary

No.	Abbreviations/Word	Description
1	Compensation curve mode	Space heating incorporating outdoor ambient temperature compensation
2	COP	Coefficient of Performance the efficiency of the heat pump
3	Cylinder unit	Indoor unvented DHW tank and component plumbing parts
4	DHW mode	Domestic hot water heating mode for showers, sinks, etc
5	Flow temperature	Temperature at which water is delivered to the primary circuit
6	Freeze stat. function	Heating control routine to prevent water pipes freezing
7	FTC	Flow temperature controller, the circuit board in charge of controlling the system
8	Heating mode	Space heating through radiators or Underfloor heating
9	Legionella	Bacteria potentially found in plumbing, showers and water tanks that may cause Legionnaires disease
10	LP mode	Legionella prevention mode – a function on systems with water tanks to prevent the growth of legionella bacterium
11	Packaged model	Plate heat exchanger (Refrigerant - Water) in the outdoor heat pump unit
12	PRV	Pressure relief valve
13	Return temperature	Temperature at which water is delivered from the primary circuit
14	Split model	Plate heat exchanger (Refrigerant - Water) in the indoor unit
15	TRV	Thermostatic radiator valve – a valve on the entrance or exit of the radiator panel to control the heat output
16	Cooling mode	Space cooling through fan-coils or underfloor cooling

1 Safety Notices

Please read the following safety precautions carefully.

⚠ WARNING:
Precautions that must be observed to prevent injuries or death.

⚠ CAUTION:
Precautions that must be observed to prevent damage to unit.

**This installation manual along with the user manual should be left with the product after installation for future reference.
Mitsubishi Electric is not responsible for the failure of locally-supplied parts.**

- Be sure to perform periodical maintenance.
- Be sure to follow your local regulations.
- Be sure to follow the instructions provided in this manual.

⚠ WARNING

Mechanical

- The cylinder unit and outdoor unit must not be installed, disassembled, relocated, altered or repaired by the user. Ask an authorised installer or technician. If the unit is installed improperly or modified after installation by the user water leakage, electric shock or fire may result.
- The outdoor unit should be securely fixed to a hard level surface capable of bearing its weight.
- The cylinder unit should be positioned on a hard level surface capable of supporting its filled weight to prevent excessive sound or vibration.
- Do not position furniture or electrical appliances below the outdoor unit or cylinder unit.
- The discharge pipework from the emergency devices of the cylinder unit should be installed according to local law.
- Only use accessories and replacement parts authorised by Mitsubishi Electric ask a qualified technician to fit the parts.

Electrical

- All electrical work should be performed by a qualified technician according to local regulations and the instructions given in this manual.
- The units must be powered by a dedicated power supply and the correct voltage and circuit breakers must be used.
- Wiring should be in accordance with national wiring regulations. Connections must be made securely and without tension on the terminals.
- Earth unit correctly.

General

- Keep children and pets away from both the cylinder unit and outdoor unit.
- Do not use the hot water produced by the heat pump directly for drinking or cooking. This could cause illness to the user.
- Do not stand on the units.
- Do not touch switches with wet hands.
- Annual maintenance checks on both the cylinder unit and the outdoor unit should be conducted by a qualified person.
- Do not place containers with liquids on top of the cylinder unit. If they leak or spill onto the cylinder unit damage to the unit and/or fire could occur.
- Do not place any heavy items on top of the cylinder unit.
- When installing, relocating, or servicing the cylinder unit, use only the specified refrigerant (R410A) to charge the refrigerant lines. Do not mix it with any other refrigerant and do not allow air to remain in the lines. If air is mixed with the refrigerant, then it can be the cause of abnormal high pressure in the refrigerant line, and may result in an explosion and other hazards.
- The use of any refrigerant other than that specified for the system will cause mechanical failure or system malfunction or unit breakdown. In the worst case, this could lead to a serious impediment to securing product safety.
- In heating mode, to avoid the heat emitters being damaged by excessively hot water, set the target flow temperature to a minimum of 2°C below the maximum allowable temperature of all the heat emitters. For Zone2, set the target flow temperature to a minimum of 5°C below the maximum allowable flow temperature of all the heat emitters in Zone2 circuit.
- Do not install the unit where combustible gases may leak, be produced, flow, or accumulate. If combustible gas accumulates around the unit, fire or explosion may result.

⚠ CAUTION

- Use clean water that meets local quality standards on the primary circuit.
- The outdoor unit should be installed in an area with sufficient airflow according to the diagrams in the outdoor unit installation manual.
- The cylinder unit should be located inside to minimise heat loss.
- Water pipe-runs on the primary circuit between outdoor and indoor unit should be kept to a minimum to reduce heat loss.
- Ensure condensate from outdoor unit is piped away from the base to avoid puddles of water.
- Remove as much air as possible from the primary and DHW circuits.
- Refrigerant leakage may cause suffocation. Provide ventilation in accordance with EN378-1.
- Be sure to wrap insulation around the piping. Direct contact with the bare piping may result in burns or frostbite.
- Never put batteries in your mouth for any reason to avoid accidental ingestion.
- Battery ingestion may cause choking and/or poisoning.
- Install the unit on a rigid structure to prevent excessive sound or vibration during operation.
- Do not transport the cylinder unit with water inside the DHW tank. This could cause damage to the unit.
- If power to the cylinder unit is to be turned off (or system switched off) for a long time, the water should be drained.
- If unused for a long period, before operation is resumed, DHW tank should be flushed through with potable water.
- Preventative measures should be taken against water hammer, such as installing a Water Hammer Arrestor on the primary water circuit, as directed by the manufacturer.

As for the handling of refrigerant, refer to the outdoor unit installation manual.

2 Introduction

The purpose of this installation manual is to instruct competent persons how to safely and efficiently install and commission the cylinder unit system. The target readers of this manual are competent plumbers and/or refrigeration engineers

who have attended and passed the requisite Mitsubishi Electric product training and have appropriate qualifications for installation of an unvented hot water cylinder unit specific to their country.

Product specification

Model name	EHST20C-VM2C	EHST20C-VM6C	EHST20C-VM9C	EHST20C-VM2EC	EHST20C-VM6EC	EHST20C-VM9EC	EHST20C-MEC	EHST20D-VM2C	EHST20D-MHC	EHST20D-VM2EC	EHST20D-VM9C	
Nominal domestic hot water volume	200L											
Overall unit dimensions	1600 × 595 × 680 mm (Height × Width × Depth)											
Weight (empty)	110 kg	111 kg	112 kg	104 kg	105 kg	106 kg	103 kg	103 kg	103 kg	96 kg	103 kg	105 kg
Water volume of heating circuit in the unit *1	320 kg	321 kg	322 kg	314 kg	315 kg	316 kg	313 kg	312 kg	312 kg	305 kg	312 kg	314 kg
Plate heat exchanger (MWA2)	6.6 kg	6.6 kg	6.6 kg	6.6 kg	6.6 kg	6.6 kg	6.6 kg	5.7 kg	5.7 kg	5.7 kg	5.7 kg	5.7 kg
Plate heat exchanger (MWA1)	✓	✓	✓	✓	✓	✓	✓	✓	✓	✓	✓	✓
Unvented expansion vessel(Primary heating)	—	—	—	—	—	—	—	—	—	—	—	—
Nominal volume	12 L											
Charge pressure	1 bar											
Control thermistor circuit (Primary)	1 - 80°C											
Heating thermistor	0.3 MPa (3bar)											
Pressure relief valve	Min. flow 5.0 L/min											
Flow sensor	—											
Manual reset thermostat	90°C											
Thermal Cut-out (for dry run prevention)	121°C											
Control thermistor	40 - 70°C											
Temperature and pressure relief valve/Pressure relief valve	1.0 MPa (10 bar)											
Primary circuit circulating Pump	Grundfos UPM2 15-70 130											
Sanitary circuit circulating Pump	Grundfos UPSO 15-60 130 CIL2											
Water	28mm compression primary circuit/ 22mm compression DHW circuit											
Refrigerant (R410A)	Liquid											
Gas	9.52 mm											
Heating	15.88 mm											
Flow temperature	25 - 60°C											
Cooling	—											
Room temperature	10 - 30°C											
Cooling	—											
Ambient *2	0 - 35°C (≤ 80 %RH)											
Outdoor temperature	See outdoor unit spec table.											
Heating	70°C											
Cooling	—											
Maximum allowable hot water temperature	—											
Time to raise DHW tank temp. 15 - 65 °C *5	22.75 min											
Time to reheat 70% of DHW tank to 65 °C *5	17.17 min											
Control board	~N, 230 V, 50 Hz											
Power supply (Phase, voltage, frequency)	10A											
Breaker (*when powered from independent source)	—											
Power supply (Phase, voltage, frequency)	~N, 230 V, 50 Hz	~N, 230 V, 50 Hz	3~, 230 V, 50 Hz	~N, 230 V, 50 Hz	~N, 230 V, 50 Hz	3~, 400 V, 50 Hz	~N, 230 V, 50 Hz	~N, 230 V, 50 Hz	~N, 230 V, 50 Hz	—	~N, 230 V, 50 Hz	3~, 400 V, 50 Hz
Capacity	2kW	2kW+4kW	3kW+6kW	2kW	2kW+4kW	3kW+6kW	2kW	2kW	2kW	—	2kW	3kW+6kW
Current	9 A	26 A	13A	9 A	26 A	13A	9 A	9 A	9 A	—	9 A	13A
Breaker	16 A	32 A	32A	16 A	32 A	32A	16 A	16 A	16 A	—	16 A	16 A
Power supply (Phase, voltage, frequency)	~N, 230 V, 50 Hz											
Capacity	—											
Current	—											
Breaker	—											
Sound pressure level	28dB(A)											
Sound power level	40dB(A)											

<Table 3.1>

Optional extras

- Wireless Remote Controller PAB-WT50R-E
 - Wireless Receiver PAB-WR51R-E
 - Immersion heater (1Pb 3kW) PAC-IH03V2-E
 - EHPT Accessories for UK PAC-WK01UK-E
 - Drain pan stand PAC-DP01-E
 - Joint pipe (ø15.88 → ø12.7) PAC-SH0RJE
 - Joint pipe (ø9.52 → ø6.35) PAC-SH30RJE
 - Remote Sensor PAC-SE41TS-E
 - Thermistor PAC-TH011-E
 - High temperature thermistor PAC-TH011HT-E
 - ecodan Wi-Fi Interface PAC-WF010-E
 - 2-zone kit PAC-TZ01-E
- *1 Volume of sanitary water circuit, primary DHW circuit (from 3-way valve to confluent point with heating circuit), piping to expansion vessel, and expansion vessel are not included in this value.
 *2 The environment must be frost-free.
 *3 Cooling mode is not available in low outdoor temperature.
 *4 For the model without both booster heater and immersion heater, the maximum allowable hot water temperature is [Maximum outlet water of outdoor unit - 3 °C]
 For the maximum outlet water of outdoor unit, refer to outdoor unit data book.
 *5 Tested under BS7206 conditions.
 *6 Do not fit immersion heaters without thermal cut-out.

3 Technical Information

Product specification

Model name	ERST20C-MEC	ERST20C-VM2C	ERST20D-MEC	ERST20D-VM2C	EHP20X-VM2C	EHP20X-VM6C	EHP20X-VM9C	EHP20X-TM9C	EHP20X-MHCW	EHP20C-MHCW	EHP20D-MHCW	
Nominal domestic hot water volume					1600 x 595 x 680 mm (Height x Width x Depth)							
Overall unit dimensions					200L							
Weight (empty)	103 kg	110 kg	96 kg	103 kg	98 kg	99 kg	100 kg	100 kg	98 kg	110 kg	103 kg	
Weight (full)	313 kg	320 kg	305 kg	312 kg	307 kg	308 kg	309 kg	309 kg	307 kg	320 kg	312 kg	
Water volume of heating circuit in the unit *1	6.6 kg	6.6 kg	5.7 kg	5.7 kg	5.9 kg	5.9 kg	5.9 kg	5.9 kg	5.9 kg	6.6 kg	5.7 kg	
Plate heat exchanger (MWA2)	✓	✓	✓	✓	✓	✓	✓	✓	✓	✓	✓	
Plate heat exchanger (MWA1)	—	—	—	—	—	—	—	—	—	—	—	
Unvented expansion vesse(Primary heating)	—	12 L	—	—	—	—	—	12 L	—	—	✓	
Charge pressure	—	1 bar	—	—	—	—	—	1 bar	—	—	—	
Water circuit (Primary)	Heating	Heating	Heating	Heating	1 - 80°C	1 - 80°C	1 - 80°C	1 - 80°C	1 - 80°C	1 - 80°C	1 - 80°C	
Pressure relief valve	—	—	—	—	0.3 MPa (3bar)	0.3 MPa (3bar)	0.3 MPa (3bar)	0.3 MPa (3bar)	0.3 MPa (3bar)	0.3 MPa (3bar)	0.3 MPa (3bar)	
Flow sensor	—	—	—	—	Min. flow 5.0 L/min	Min. flow 5.0 L/min	Min. flow 5.0 L/min	Min. flow 5.0 L/min	Min. flow 5.0 L/min	Min. flow 5.0 L/min	Min. flow 5.0 L/min	
Manual reset thermostat	—	90°C	—	—	90°C	90°C	90°C	90°C	—	—	—	
Thermal Cut-out (for dry run prevention)	—	121°C	—	—	121°C	121°C	121°C	121°C	—	—	—	
Control thermostat	—	—	—	—	40 - 70°C	40 - 70°C	40 - 70°C	40 - 70°C	—	—	—	
Temperature and pressure relief valve/ Pressure relief valve	—	—	—	—	1.0 MPa (10 bar)	1.0 MPa (10 bar)	1.0 MPa (10 bar)	1.0 MPa (10 bar)	—	90°C / 0.7 MPa (7 bar)	—	
Primary circuit circulating Pump	Grundfos UPM2K 15-75 130											
Sanitary circuit circulating Pump	Grundfos UPFO 15-60 130 CIL2											
Connections	Liquid	6.35 mm	6.35 mm	12.7 mm	28mm compression primary circuit/ 22mm compression DHW circuit							
Refrigerant (R410A)	Gas	—	—	—	—							
Flow temperature	Heating	5 - 25°C	—	—	25 - 60°C							
Cooling	—	—	—	—	10 - 30°C							
Room temperature	Heating	—	—	—	—							
Cooling	—	—	—	—	—							
Ambient *2	—	—	—	—	0 - 35°C (≤ 80 %RH)							
Outdoor temperature	Heating	—	—	—	See outdoor unit spec table.							
Cooling	—	—	—	—	—							
Maximum allowable hot water temperature	—	70°C	—	—	70°C							
Time to raise DHW tank temp. 15 - 65 °C *5	*4	—	*4	—	22.75 min							
Time to reheat 70% of DHW tank to 65 °C *5	—	—	—	—	17.17 min							
Control board	Power supply (Phase, voltage, frequency)	~N, 230 V, 50 Hz	—	—	~N, 230 V, 50 Hz	~N, 230 V, 50 Hz	~N, 230 V, 50 Hz	3~ 400 V, 50 Hz	3~ 230 V, 50 Hz	—	—	
Breaker (*when powered from independent source)	—	—	—	—	—	—	—	—	—	—	—	
Power supply (Phase, voltage, frequency)	Capacity	2kW	—	—	2kW	2kW	2kW	2kW+4kW	3kW+6kW	—	—	
Current	—	9 A	—	—	9 A	9 A	9 A	13 A	23 A	—	—	
Breaker	—	16 A	—	—	16 A	16 A	16 A	16 A	32 A	—	—	
Power supply (Phase, voltage, frequency)	Capacity	—	—	—	—	—	—	—	—	~N, 230 V, 50 Hz	—	
Current	—	—	—	—	—	—	—	—	—	3kW	—	
Breaker	—	—	—	—	—	—	—	—	—	13A	—	
—	—	—	—	—	—	—	—	—	—	16A	—	
Sound pressure level	28dB(A)											
Sound power level	40dB(A)											

< Table 3.1 >

Optional extras

- Wireless Remote Controller PAR-WT50R-E
- Wireless Receiver PAR-WR51R-E
- Immersion heater (1P 3kW) PAC-IH03V2-E
- EHPT Accessories for UK PAC-WK01UK-E
- Drain pan stand PAC-DP01-E
- Joint pipe (ø15.88 → ø12.7) PAC-SH60R-J-E
- Joint pipe (ø9.52 → ø6.35) PAC-SH30R-J-E
- Remote Sensor PAC-SE41TS-E
- Thermostat PAC-TH011-E
- High temperature thermostat PAC-TH011HT-E
- ecodan Wi-Fi interface PAC-WF010-E
- 2-zone kit PAC-TZ01-E
- *1 Volume of sanitary water circuit, primary DHW circuit (from 3-way valve to confluent point with heating circuit), piping to expansion vessel, and expansion vessel are not included in this value.
- *2 The environment must be frost-free.
- *3 Cooling mode is not available in low outdoor temperature.
- *4 For the model without both booster heater and immersion heater, the maximum allowable hot water temperature is [Maximum outlet water of outdoor unit - 3 °C] For the maximum outlet water of outdoor unit, refer to outdoor unit data book.
- *5 Tested under BS7206 conditions.
- *6 Do not fit immersion heaters without thermal cut-out.

3 Technical Information

Component Parts

<E*ST20*-MC>**
(Split model system)

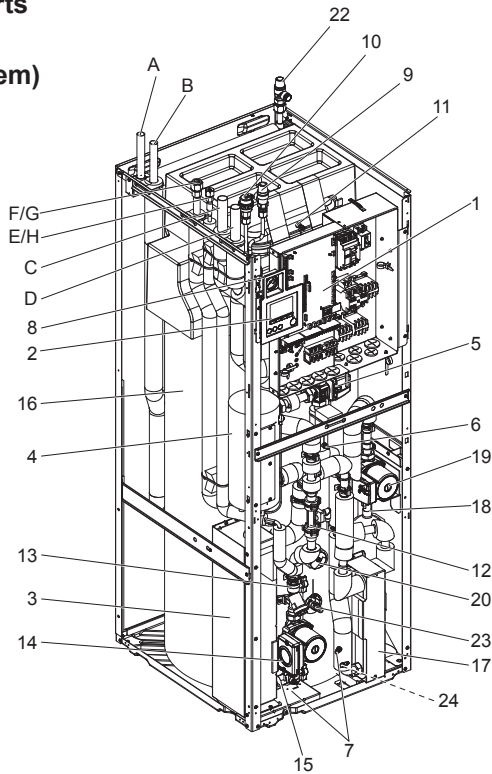

<EH*T20*-MHCW>
(UK split/package model system)

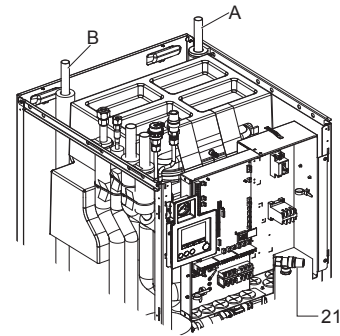

<EHPT20X-MC*>**
(Packaged model system)

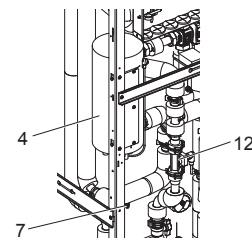

<Figure 3.1>

No.	Part name	E*ST20*-M2/6/9C	E*ST20*-M2/6/9EC	E*ST20*-MEC	EHST20D-MHC	EHPT20X-M2/6/9C	EHPT20X-MHCW	EHST20*-MHCW
A	DHW outlet pipe	✓	✓	✓	✓	✓	✓	✓
B	Cold water inlet pipe	✓	✓	✓	✓	✓	✓	✓
C	Water pipe (Space heating/cooling return connection)	✓	✓	✓	✓	✓	✓	✓
D	Water pipe (Space heating/cooling flow connection)	✓	✓	✓	✓	✓	✓	✓
E	Water pipe (Flow from heat pump connection)	—	—	—	—	✓	✓	—
F	Water pipe (Return to heat pump connection)	—	—	—	—	✓	✓	—
G	Refrigerant pipe (Gas)	✓	✓	✓	✓	—	—	✓
H	Refrigerant pipe (Liquid)	✓	✓	✓	✓	—	—	✓
1	Control and electrical box	✓	✓	✓	✓	✓	✓	✓
2	Main remote controller	✓	✓	✓	✓	✓	✓	✓
3	Plate heat exchanger (Refrigerant - Water)	✓	✓	✓	✓	—	—	✓
4	Booster heater 1,2	✓	✓	—	—	✓	—	—
5	3-way valve	✓	✓	✓	✓	✓	✓	✓
6	Manual air vent	✓	✓	✓	✓	✓	✓	✓
7	Drain cock (Primary circuit)	✓	✓	✓	✓	✓	✓	✓
8	Manometer	✓	✓	✓	✓	✓	✓	✓
9	Pressure relief valve (3bar)	✓	✓	✓	✓	✓	✓	✓
10	Automatic air vent	✓	✓	✓	✓	✓	✓	✓
11	Expansion vessel	✓	—	—	✓	✓	✓	✓
12	Flow sensor	✓	✓	✓	✓	✓	✓	✓
13	Strainer valve	✓	✓	✓	✓	✓	✓	✓
14	Water circulation pump 1 (Primary circuit)	✓	✓	✓	✓	✓	✓	✓
15	Pump valve	✓	✓	✓	✓	✓	✓	✓
16	DHW tank	✓	✓	✓	✓	✓	✓	✓
17	Plate heat exchanger (Water - Water)	✓	✓	✓	✓	✓	✓	✓
18	Scale trap	✓	✓	✓	✓	✓	✓	✓
19	Water circulation pump (Sanitary circuit)	✓	✓	✓	✓	✓	✓	✓
20	Immersion heater	—	—	—	✓	—	✓	✓
21	Temperature and pressure relief valve	—	—	—	—	—	✓	✓
22	Pressure relief valve (10bar) (DHW Tank)	✓	✓	✓	✓	✓	—	—
23	Drain cock (DHW tank)	✓	✓	✓	✓	✓	✓	✓
24	Drain cock (Sanitary circuit)	✓	✓	✓	✓	✓	✓	✓
25	Flow water temp. thermistor (THW1)	✓	✓	✓	✓	✓	✓	✓
26	Return water temp. thermistor (THW2)	✓	✓	✓	✓	✓	✓	✓
27	DHW tank water temp. thermistor (THW5)	✓	✓	✓	✓	✓	✓	✓
28	Refrigerant liquid temp. thermistor (TH2)	✓	✓	✓	✓	—	—	✓
29	Outdoor unit	—	—	—	—	—	—	—
30	Drain pipe (Local supply)	—	—	—	—	—	—	—
31	Back flow prevention device (Local supply)	—	—	—	—	—	—	—
32	Isolating valve (Local supply)	—	—	—	—	—	—	—
33	Magnetic filter (Local supply) (Recommended)	—	—	—	—	—	—	—
34	Strainer (Local supply)	—	—	—	—	—	—	—
35	Inlet control group *1	—	—	—	—	—	—	—
36	Filling loop (Ball valves, check valves and flexible hose) *1	—	—	—	—	—	—	—
37	Potable expansion vessel *1	—	—	—	—	—	—	—

*1 Supplied with UK model ONLY. Please refer to PAC-WK01UK-E Installation Manual for more information on accessories.

<Note> For installation of E*ST20*-M*EC model, make sure to install a primary-side expansion vessel in the field. (See figure 4.3.4)

<Table 3.2>

3 Technical Information

<Unit: mm>

Technical Drawings

<E**T20*-M**C>

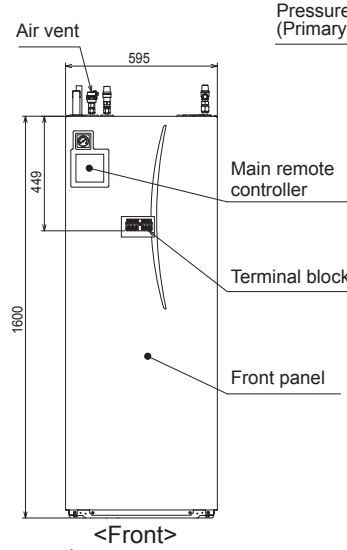
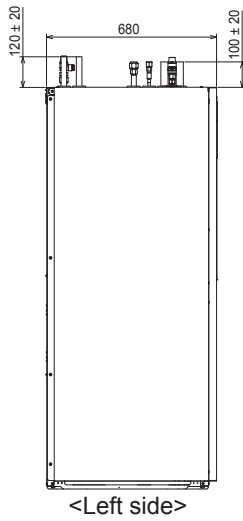

Pressure relief valve (Primary circuit)

Pressure relief valve (Sanitary circuit)

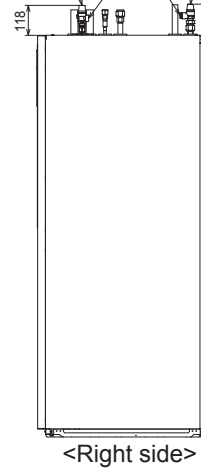

<ERST20*-M**C>

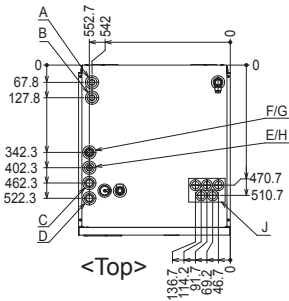
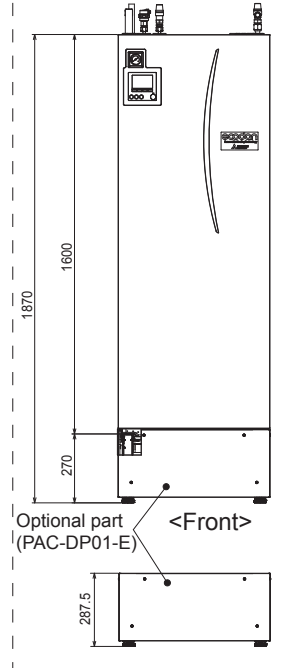

<EH*T20*-MHCW>

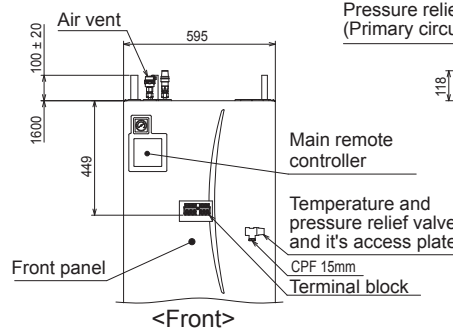
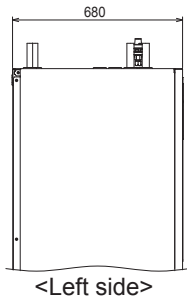

Pressure relief valve (Primary circuit)

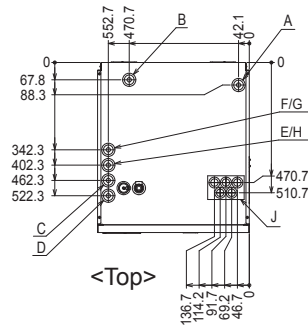
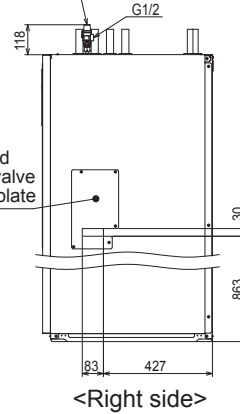

Letter	Pipe description	Connection size/type
A	DHW outlet connection	22 mm/Compression
B	Cold water inlet connection	22 mm/Compression
C	Space heating/cooling return connection	28 mm/Compression
D	Space heating/cooling flow connection	28 mm/Compression
E	Flow from heat pump connection (No plate heat exchanger)	28 mm/Compression
F	Return to heat pump connection (No plate heat exchanger)	28 mm/Compression
G	Refrigerant (GAS) (With plate heat exchanger)	12.7 mm/Flare (E*ST20D-*) 15.88 mm/Flare (E*ST20C-*)
H	Refrigerant (LIQUID) (With plate heat exchanger)	6.35 mm/Flare (E*ST20D-*) 9.52 mm/Flare (E*ST20C-*)
J	Electrical cable inlets 	For inlets ①, ② and ③, run low-voltage wires including external input wires and thermostat wires. For inlets ④ and ⑤, run high-voltage wires including power cable, indoor-outdoor cable, and external output wires. *For a wireless receiver (option) cable and ecodan Wi-Fi interface (option) cable, use inlet ①.

<Table 3.3>

EN

3 Technical Information

Unit Compatibility

Cylinder unit		EHPT20X-VM2C	EHPT20X-VM6C	EHPT20X-VM9C	EHPT20X-TM9C	EHPT20X-MHCW	EHST20D-VM2C	EHST20D-MEC	EHST20D-MHC	EHST20D-VM2EC	EHST20D-VM9C	ERST20D-MEC	ERST20D-VM2C	EHST20D-MHCW
Outdoor unit														
Split model	PUHZ-W50, 85, 112 PUHZ-HW112, 140	✓	✓	✓	✓	✓	—	—	—	—	—	—	—	—
Split model	SUHZ-SW45	—	—	—	—	—	✓	✓	✓	✓	✓	✓	✓	✓
Split model	PUHZ-SW40, 50, 75 (See below.)	—	—	—	—	—	✓	✓	✓	✓	✓	✓	✓	✓

Cylinder unit		EHST20C-VM2C	EHST20C-VM6C	EHST20C-VM9C	EHST20C-TM9C	EHST20C-VM2EC	EHST20C-VM6EC	EHST20C-VM9EC	EHST20C-MEC	ERST20C-MEC	ERST20C-VM2C	EHST20C-MHCW
Outdoor unit												
Split model	PUHZ-FRP71	✓	✓	✓	✓	✓	✓	✓	✓	—	—	✓
Split model	PUHZ-SW75, 100, 120 PUHZ-SHW80, 112, 140	✓	✓	✓	✓	✓	✓	✓	✓	✓	✓	✓
Split model	PUMY-P112, 125, 140*KM*2	✓	✓	✓	✓	✓	✓	✓	—	—	—	✓

<Table 3.4>

- When connecting E*ST20D-* to PUHZ-SW75, the following refrigerant joint pipes are necessary.
PAC-SH50RJ-E (ø15.88 → ø12.7 for gas refrigerant pipe)
PAC-SH30RJ-E (ø9.52 → ø6.35 for liquid refrigerant pipe)

Water circuit diagram

- Refer to <Table 3.2> for the part names.
- *1 Refer to the following section [Local system].

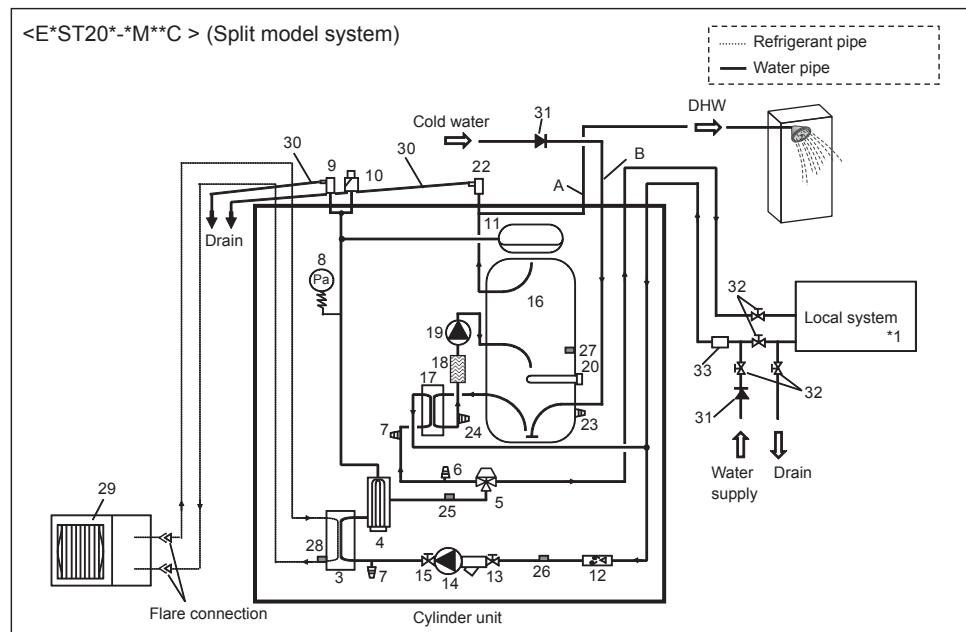

<Figure 3.2>

Note

- To enable draining of the cylinder unit an isolating valve should be positioned on both the inlet and outlet pipework.
- Be sure to install a strainer on the inlet pipework to the cylinder unit.
- Suitable drain pipework should be attached to all relief valves in accordance with your country's regulations.
- A backflow prevention device must be installed on the cold water supply pipework (IEC 61770)
- When using components made from different metals or connecting pipes made of different metals insulate the joints to prevent any corrosive reaction taking place which may damage the pipework.

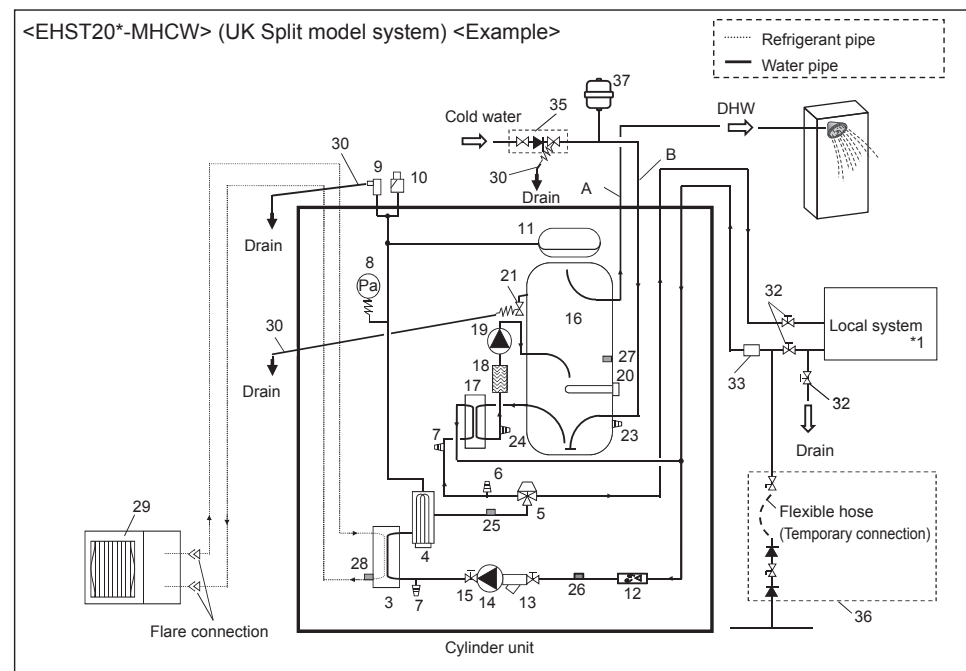

<Figure 3.3>

Note

- To enable draining of the cylinder unit an isolating valve should be positioned on both the inlet and outlet pipework. No valve should be fitted between the expansion valve (item 35) and the cylinder unit (safety matter).
- Be sure to install a strainer on the inlet pipework to the cylinder unit.
- Suitable drain pipework should be attached to all relief valves in accordance with your country's regulations.
- When using components made from different metals or connecting pipes made of different metals insulate the joints to prevent any corrosive reaction taking place which may damage any pipework.
- Filling loop's flexible hose must be removed following the filling procedure. Item provided with unit as loose accessory.
- Install the inlet control group (item 33) above the level of the T&P relief valve (item 19). This will ensure DHW tank will not require drain-down to service/maintain the inlet control group.

3 Technical Information

• Refer to <Table 3.2> for the part names.

*1 Refer to the following section [Local system].

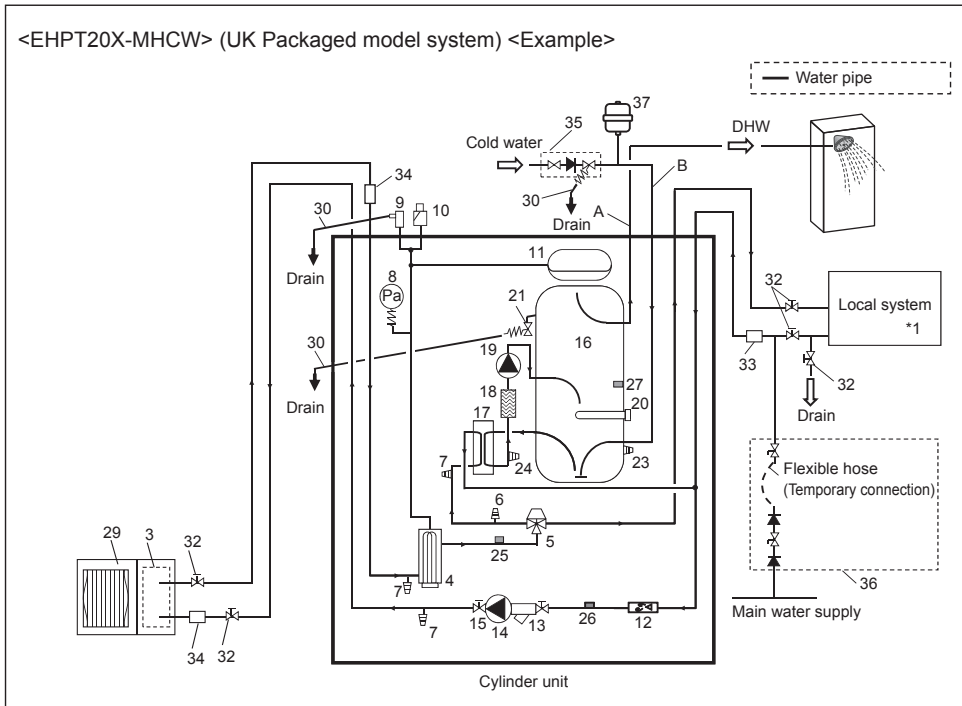

Note

- To enable draining of the cylinder unit an isolating valve should be positioned on both the inlet and outlet pipework. No valve should be fitted between the expansion valve (item 35) and the cylinder unit (safety matter).
- Be sure to install a strainer on the inlet pipework to the cylinder unit.
- Suitable drain pipework should be attached to all relief valves in accordance with your country's regulations.
- When using components made from different metals or connecting pipes made of different metals insulate the joints to prevent any corrosive reaction taking place which may damage any pipework.
- Filling loop's flexible hose must be removed following the filling procedure. Item provided with unit as loose accessory.
- Install the inlet control group (item 33) above the level of the T&P relief valve (item 19). This will ensure DHW tank will not require drain-down to service/maintain the inlet control group.

<Figure 3.4>

Model name	EHPT20X-MHCW	EHST20C-MHCW	EHST20D-MHCW
Maximum supply pressure to the pressure reducing valve	16 bar	16 bar	16 bar
Operating pressure (Potable side)	3.5 bar	3.5 bar	3.5 bar
Expansion vessel charge setting pressure (Potable side)	3.5 bar	3.5 bar	3.5 bar
Expansion valve setting pressure (Potable side)	6.0 bar	6.0 bar	6.0 bar
Immersion heater specification (Potable side) *	3000 W, 230 V	3000 W, 230 V	3000 W, 230 V
DHW tank capacity	200 L	200 L	200 L
Mass of the unit when full	307 kg	320 kg	312 kg
Maximum primary working pressure	2.5 bar	2.5 bar	2.5 bar

* EN60335/Type 3000W single phase 230V 50Hz, length 460 mm.
Use only Mitsubishi Electric service parts as a direct replacement.

<Table 3.5>

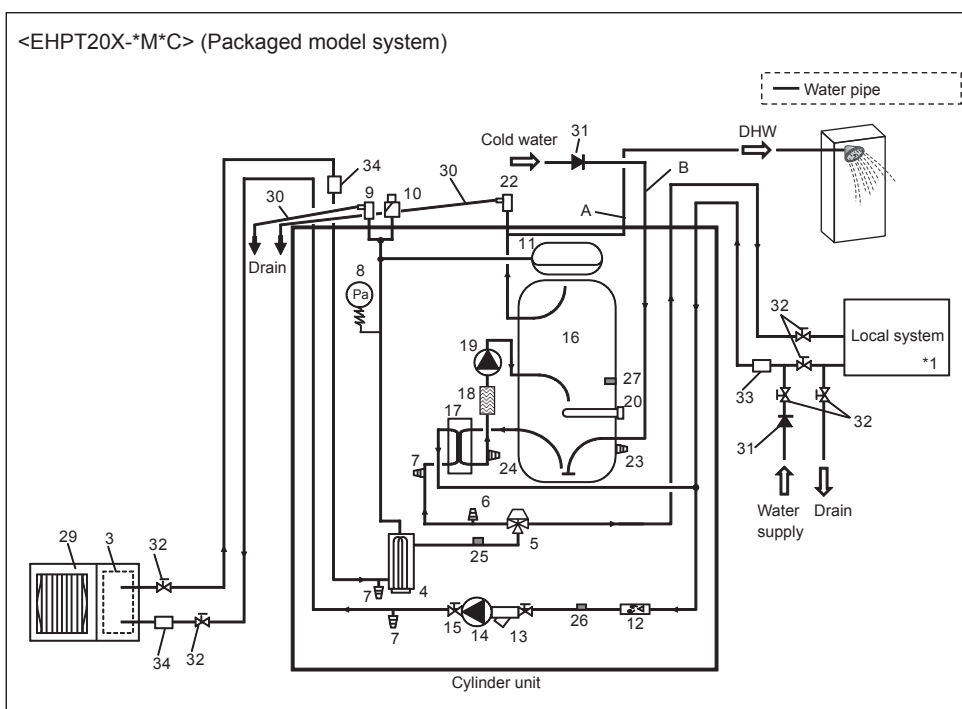

Note

- To enable draining of the cylinder unit an isolating valve should be positioned on both the inlet and outlet pipework.
- Be sure to install a strainer on the inlet pipework to the cylinder unit.
- Suitable drain pipework should be attached to all relief valves in accordance with your country's regulations.
- A backflow prevention device must be installed on the cold water supply pipework (IEC 61770)
- When using components made from different metals or connecting pipes made of different metals insulate the joints to prevent any corrosive reaction taking place which may damage the pipework.)

<Figure 3.5>

3 Technical Information

Local system

1-zone temperature control

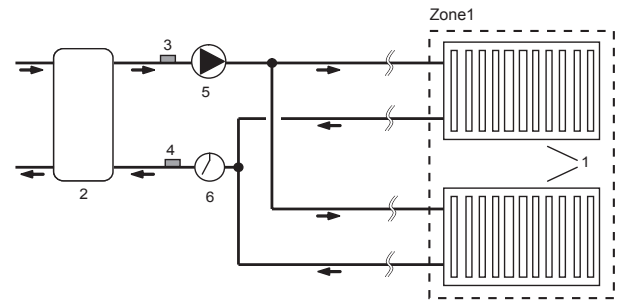
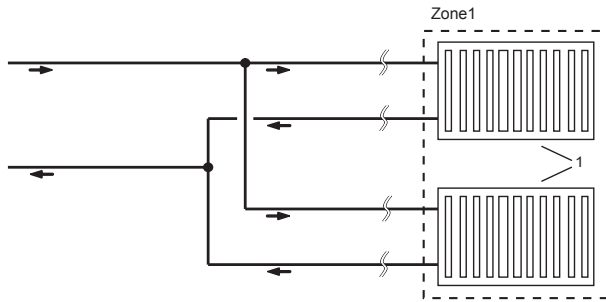

2-zone temperature control

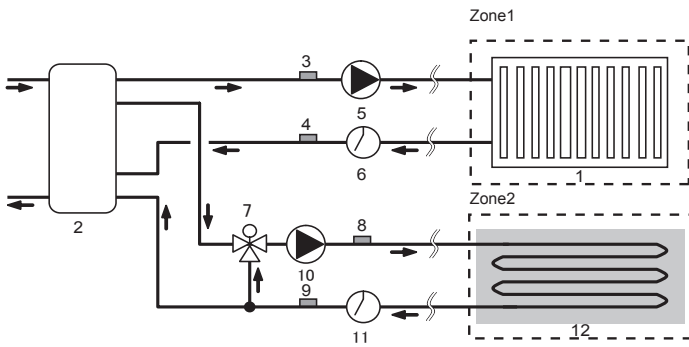

1-zone temperature control with boiler

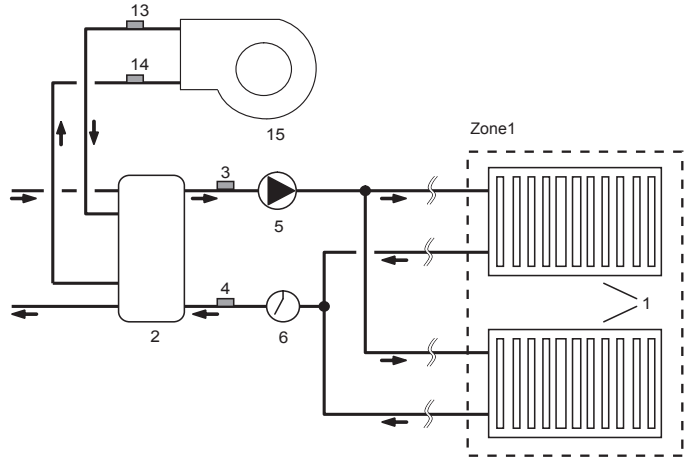

2-zone temperature control with boiler

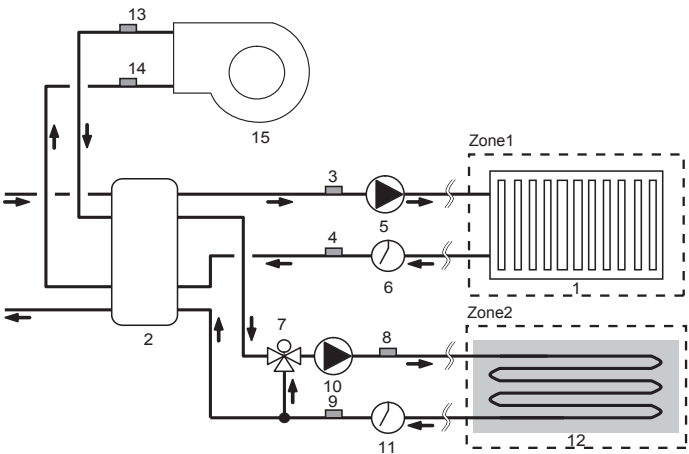

1-zone temperature control (2-zone valve ON/OFF control)

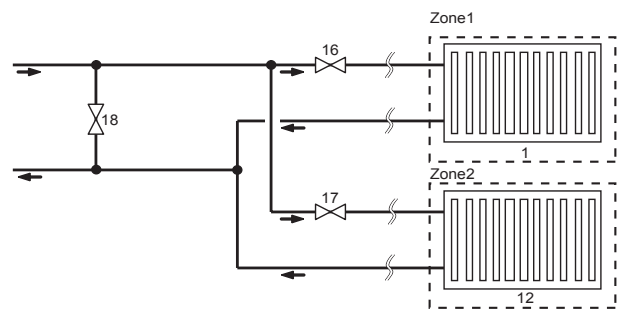

- 1. Zone1 heat emitters (e.g. radiator, fan coil unit) (local supply)
- 2. Mixing tank (local supply)
- 3. Zone1 flow water temp. thermistor (THW6)
- 4. Zone1 return water temp. thermistor (THW7) } Optional part : PAC-TH011-E
- 5. Zone1 water circulation pump (local supply)
- 6. Zone1 flow switch (local supply) *
- 7. Motorized mixing valve (local supply)
- 8. Zone2 flow water temp. thermistor (THW8)
- 9. Zone2 return water temp. thermistor (THW9) } Optional part : PAC-TH011-E

- 10. Zone2 water circulation pump (local supply)
- 11. Zone2 flow switch (local supply) *
- 12. Zone2 heat emitters (e.g. underfloor heating) (local supply)
- 13. Boiler flow water temp. thermistor (THWB1)
- 14. Boiler return water temp. thermistor (THWB2) } Optional part : PAC-TH011HT-E
- 15. Boiler (local supply)
- 16. Zone1 2-way valve (local supply)
- 17. Zone2 2-way valve (local supply)
- 18. Bypass valve (local supply)

* Flow switch specifications: 12 V DC / 1 mA / Both normally-open and normally-closed types can be used. (Set DIP switch 3 to select the logics. Refer to "5.1 DIP switch function".)

3 Technical Information

■ Energy monitor

End user can monitor accumulated*1 'Consumed electrical energy' and 'Delivered heat energy' in each operation mode*2 on the main remote controller.

*1 Monthly and Year to date

*2 - DHW operation

- Space heating
- Space cooling

Refer to "5.9 Main remote controller" for how to check the energy, and "5.1 DIP switch functions" for the details on DIP-SW setting.

Either one of the following two method is used for monitoring.

Note: Method 1 should be used as a guide. If a certain accuracy is required, the 2nd method should be used.

1. Calculation internally

Electricity consumption is calculated internally based on the energy consumption of outdoor unit, electric heater, water pump(s) and other auxiliaries. (*3)

Delivered heat is calculated internally by multiplying delta T (Flow and Return temp.) and flow rate measured by the factory fitted sensors.

Set the electric heater capacity and water pump(s) input according to indoor unit model and specs of additional pump(s) supplied locally. (Refer to the menu tree in "5.9 Main remote controller")

	Booster heater1	Booster heater2	Immersion heater*1	Pump1*2	Pump2	Pump3
Default	2kW	4kW	0kW	*** (factory fitted pump)	0kW	0kW
EHST20C-VM2C	2kW	0kW	0kW	***	When additional pumps supplied locally are connected as Pump2/3, change setting according to specs of the pumps.	
EHST20C-VM6C	2kW	4kW	0kW	***		
EHST20C-YM9C	3kW	6kW	0kW	***		
EHST20C-TM9C	3kW	6kW	0kW	***		
EHST20C-VM2EC	2kW	0kW	0kW	***		
EHST20C-VM6EC	2kW	4kW	0kW	***		
EHST20C-YM9EC	3kW	6kW	0kW	***		
EHST20C-MEC	0kW	0kW	0kW	***		
EHST20D-VM2C	2kW	0kW	0kW	***		
EHST20D-MEC	0kW	0kW	0kW	***		
EHST20D-MHC	0kW	0kW	3kW	***		
EHST20D-VM2EC	2kW	0kW	0kW	***		
EHST20D-YM9C	3kW	6kW	0kW	***		
ERST20C-MEC	0kW	0kW	0kW	***		
ERST20C-VM2C	2kW	0kW	0kW	***		
ERST20D-MEC	0kW	0kW	0kW	***		
ERST20D-VM2C	2kW	0kW	0kW	***		
EHPT20X-VM2C	2kW	0kW	0kW	***		
EHPT20X-VM6C	2kW	4kW	0kW	***		
EHPT20X-YM9C	3kW	6kW	0kW	***		
EHPT20X-TM9C	3kW	6kW	0kW	***		
EHPT20X-MHCW	0kW	0kW	3kW	***		
EHST20C-MHCW	0kW	0kW	3kW	***		
EHST20D-MHCW	0kW	0kW	3kW	***		

<Table 3.6>

*1 Change setting to 3kW when connecting optional immersion heater "PAC-IH03V2-E".

*2 "****" displayed in the energy monitor setting mode means the factory fitted pump is connected as Pump 1 so that the input is automatically calculated.

*3 When the cylinder unit is connected with a PUHZ-FRP or PUMY models, electricity consumption is not calculated internally. To display the electricity consumption, conduct the 2nd method.

When anti-freeze solution (propylene glycol) is used for primary water circuit, set the delivered energy adjustment if necessary.

For further detail of above, refer to "5.9 Main remote controller".

2. Actual measurement by external meter (locally supplied)

FTC has external input terminals for 2 'Electric energy meters' and a 'Heat meter'.

If two 'Electric energy meters' are connected, the 2 recorded values will be combined at the FTC and shown on the main remote controller.

(e.g. Meter 1 for H/P power line, Meter 2 for heater power line)

Refer to the [Signal inputs] section in "5.2 Connecting inputs/outputs" for more information on connectable electric energy meter and heat meter.

4 Installation

<Preparation before the installation and service>

- Prepare the proper tools.
- Prepare the proper protection.
- Allow parts to cool before attempting any maintenance.
- Provide adequate ventilation.
- After stopping the operation of the system, turn off the power-supply breaker and remove the power plug.
- Discharge the capacitor before commencing work involving the electric parts.

<Precautions during service>

- Do not perform work involving electric parts with wet hands.
- Do not pour water or liquid into the electric parts.
- Do not touch the refrigerant.
- Do not touch the hot or cold surfaces in the refrigerant cycle.
- When the repair or the inspection of the circuit needs to be carried out without turning off the power, exercise great caution not to touch any live parts.

EN

4.1 Location

■ Transportation and Handling

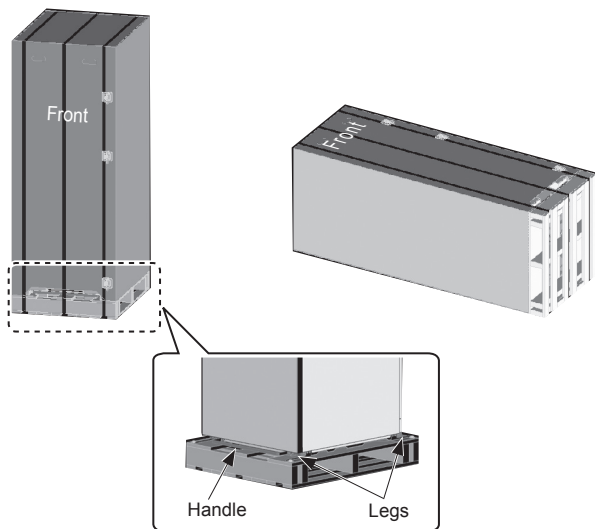

<Figure 4.1.1>

Cylinder unit is delivered on a wooden pallet base with cardboard protection.

Care should be taken when transporting the cylinder unit that the casing is not damaged by impact. Do not remove the protective packaging until cylinder unit has reached its final location. This will help protect the structure and control panel.

- The cylinder unit can be transported either vertically or horizontally. If transported horizontally the panel marked 'Front' must be facing **UPWARDS** <Figure 4.1.1>.
- The cylinder unit should **ALWAYS** be moved by a minimum of 2 people.
- When carrying the cylinder unit use the handles provided.
- Before using the handles, make sure they are securely attached.
- **Please remove front handle, fixing legs, wooden base and any other packaging once the unit is in installation location.**
- **Keep the handles for future transportation.**

■ Suitable Location

Before installation the cylinder unit should be stored in a frost-free weather-proof location. Units must **NOT** be stacked.

- The cylinder unit should be installed indoors in a frost free weather proof location.
- The cylinder unit should be positioned on a level surface capable of supporting it's filled weight. (Adjustable feet (accessory parts) can be used to ensure unit is level)
- When using the adjustable feet, ensure that the floor is strong enough.
- Care should be taken that minimum distances around and in front of the unit for service access are observed <Figure 4.1.2>.
- Secure the cylinder unit to prevent it being knocked over.
- Install the cylinder unit where it is not exposed to water/excessive moisture.

■ Service access diagrams

Service access	
Parameter	Dimension (mm)
a	300*
b	150
c (distance behind unit not visible in Figure 4.1.2)	10
d	500

<Table 4.1.1>

Sufficient space **MUST** be left for the provision of discharge pipework as detailed in National and Local Building Regulations.

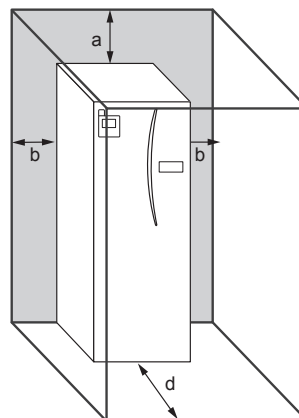

<Figure 4.1.2>

Service access

* An additional 300 mm of space (total 600 mm) is required, when installing the optional 2-zone kit (PAC-TZ01-E) on top of the cylinder unit.

The cylinder unit must be located indoors and in a frost-free environment, for example in a utility room, to minimise heat loss from stored water.

■ Room Thermostat

If fitting a new room thermostat for this system;

- Position it out of direct sunlight and draughts
- Position it away from internal heat sources
- Position it in a room without a TRV on the radiator/heat emitter.
- Position it on an internal wall

Note: Do not position the thermostat excessively close to the external wall. The thermostat may detect the temperature of the wall, which could affect appropriate control of the room temperature.

- Position it approx. 1.5 m from floor level

■ Repositioning

If you need to move the cylinder unit to a new position **FULLY DRAIN** the cylinder unit before moving to avoid damage to the unit.

4 Installation

4.2 Water Quality and System Preparation

■ General

- The water in both primary and sanitary circuit should be clean and with pH value of 6.5-8.0
- The followings are the maximum values;
 - Calcium: 100mg/L, Ca hardness: 250mg/L
 - Chlorine: 100mg/L, Copper: 0.3mg/L
 - Iron/Manganese: 0.5mg/L
- Other constituents should be to European Directive 98/83 EC standards.
- In known hard water areas, to prevent/minimise scaling, it is beneficial to restrict the routine stored water temperature (DHW max. temp.) to 55°C.

■ Anti-Freeze

Anti-freeze solutions MUST use propylene glycol with a toxicity rating of Class 1 as listed in Clinical Toxicology of Commercial Products, 5th Edition.

Note:

- Ethylene glycol is toxic and must **NOT** be used in the primary water circuit in case of any cross-contamination of the potable circuit.
- For 2-zone valve ON/OFF control, propylene glycol **MUST** be used.

■ New Installation (primary water circuit)

- Before connecting outdoor unit, thoroughly cleanse pipework of building debris, solder etc using a suitable chemical cleansing agent.
- Flush the system to remove chemical cleanser.
- For all packaged model systems add a combined inhibitor and anti-freeze solution to prevent damage to the pipework and system components.
- For split model systems the responsible installer should decide if anti-freeze solution is necessary for each site's conditions. Corrosion inhibitor however should always be used.

■ Existing Installation (primary water circuit)

- Before connecting outdoor unit the existing heating circuit **MUST** be chemically cleansed to remove existing debris from the heating circuit.
- Flush the system to remove chemical cleanser.
- For all packaged model systems, and the split model or PUMY system without booster heater, add a combined inhibitor and anti-freeze solution to prevent damage to the pipework and system components.
- For split model systems the responsible installer should decide if anti-freeze solution is necessary for each site's conditions. Corrosion inhibitor however should always be used.

When using chemical cleansers and inhibitors always follow manufacturer's instructions and ensure the product is appropriate for the materials used in the water circuit

■ How to access Internal Components and Control and Electrical Box

<A> Opening the front panel

- Remove the two lower screws.
- Slide front panel upwards to slightly and open carefully.
- Disconnect the relay connector connecting main remote controller cable and the control board cable.

 Accessing the back of the control and electrical box

The control and electrical box has 3 holding screws and is hinged on the right hand side.

- Remove the holding screws on the control and electrical box.
- The control and electrical box can then be swung forward on the right hand hinges.

Note:

After servicing, re-secure all cables using straps provided. Reconnect main remote controller cable to its relay connector. Replace front panel and re-secure screws at base.

■ Minimum amount of water required in the space heating/cooling circuit

	Outdoor heat pump unit	Minimum water quantity [L]
Packaged model	PUHZ-W50	29
	PUHZ-W85	37
	PUHZ-W112	48
	PUHZ-HW112	48
	PUHZ-HW140	60
Split model	SUHZ-SW45	17
	PUHZ-SW40	17
	PUHZ-SW50	22
	PUHZ-FRP71	32
	PUHZ-SW75	32
	PUHZ-SW100	43
	PUHZ-SW120	54
	PUHZ-SHW80	34
	PUHZ-SHW112	48
	PUHZ-SHW140	60
	PUMY-P112	80
	PUMY-P125	80
	PUMY-P140	80

<Table 4.2.1>

Note:

For 2-zone temperature control system, the value in the table above excludes the amount of stored water in zone2.

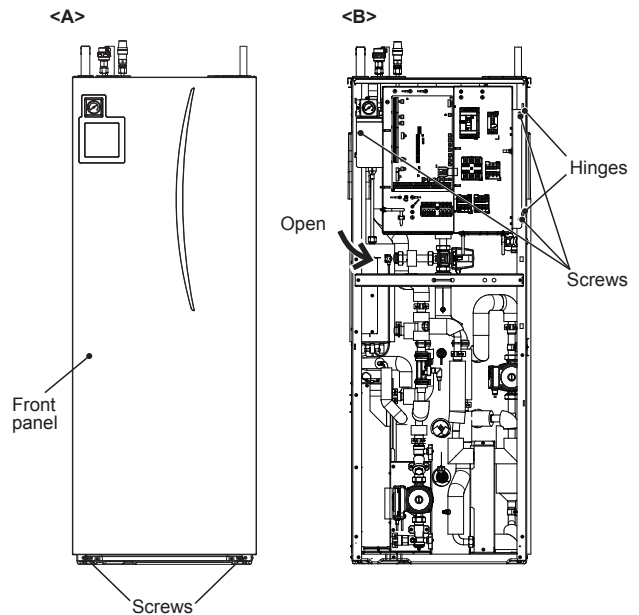

<Figure 4.2.1>

4 Installation

4.3 Water Pipe Work

■ Hot Water Pipework

The cylinder unit is **UNVENTED**. When installing unvented hot water systems building regulations part G3 (England and Wales), P3 (Scotland) and P5 (Northern Ireland) should be adhered to. If outside of the UK please adhere to your own country's regulations for unvented hot water systems.

Connect the flow for the DHW to pipe A (Figure 3.1).

The function of the following safety components of the cylinder unit should be checked on installation for any abnormalities;

- Pressure relief valve (Primary circuit and Tank)
- Expansion vessel pre-charge (gas charge pressure)

The instruction on the following pages regarding safe discharge of hot water from Safety devices should be followed carefully.

- The pipework will become very hot, so should be insulated to prevent burns.
- When connecting pipework, ensure that no foreign objects such as debris or the like do not enter the pipe.

■ Cold Water Pipework

Cold water to the suitable standard (see section 4.2) should be introduced to the system by connecting pipe B (Figure 3.1) using appropriate fittings.

■ Drain Pipework (ONLY ERST20* series)

To drain correctly, it is necessary to use optional part 'Drain pan stand (PAC-DP01-E)' The drain pan and drain pipe should be installed to drain condensed water during cooling mode.

- To prevent dirty water from draining directly onto the floor next to cylinder unit, please connect appropriate discharge pipework from the cylinder drain pan.
- Securely install the drain pipe to prevent leakage from the connection.
- Securely insulate the drain pipe to prevent water dripping from the locally supplied drain pipe.
- Install the drain pipe at a down slope of 1/100 or more.
- Do not place the drain pipe in drain channel where sulfuric gas exists.
- After installation, check that the drain pipe drains water properly from the outlet of the pipe to suitable discharge location.

■ Negative pressure prevention

To prevent negative pressure effecting DHW tank, installer should install appropriate pipework or use appropriate devices.

■ Hydraulic filter work (ONLY EHPT series)

Install a hydraulic filter or strainer (local supply) at the water intake ("Pipe E" in Fig.3.1)

■ Pipework Connections

Connections to the cylinder unit should be made using the 22 mm or 28 mm compression as appropriate.

Do not over-tighten compression fittings as this will lead to deformation of the olive ring and potential leaks.

Note: To weld the pipes in the field, cool the pipes on the cylinder unit using wet towel etc.

■ Insulation of Pipework

- All exposed water pipework should be insulated to prevent unnecessary heat loss and condensation. To prevent condensate entering the cylinder unit, the pipework and connections at the top of the cylinder unit should be carefully insulated.
- Cold and hot water pipework should not be run close together where possible, to avoid unwanted heat transfer.
- Pipework between outdoor heat pump unit and cylinder unit should be insulated with suitable pipe insulation material with a thermal conductivity of ≤ 0.04 W/m.K.

<Installation>

Note: It may be more convenient to fit the drain hose prior to positioning the cylinder unit upon the stand.

1. Insert the drain socket deeply into the drain hose. (Figure 4.3.1)
2. Fix the drain hose with the tie band.
3. Apply polyvinyl chloride type adhesive over the shaded surfaces inside of the drain pipe and on the exterior of the drain socket as shown.
4. Insert the drain socket deeply into the drain pipe. (Figure 4.3.1)

Note: Securely support the locally supplied drain pipe to avoid the drain pipe falling from the drain socket.

<Checking drainage>

- Remove the front panel and gradually pour 1 liter of water into the drain pan. (Figure 4.3.2)
- Check that the drain pipe drains water properly from the outlet of the pipe.
- Check for any leakage from the connections.

Note: 1. Always check drainage at installation regardless of season.

2. Pour water slowly into the drain pan so that water dose not overflow from the drain pan.

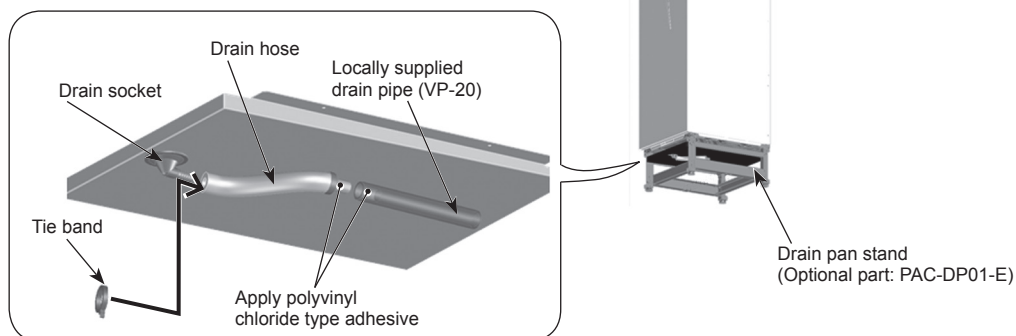

<Figure 4.3.1>

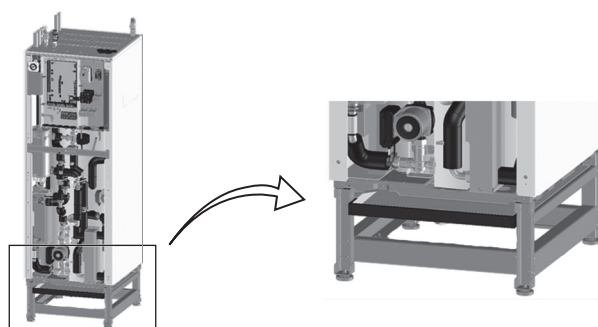

<Figure 4.3.2>

4 Installation

■ Filling the System (Primary Circuit)

1. Check and charge expansion vessel.
2. Check all connections including factory fitted ones are tight.
3. Insulate pipework between cylinder unit and outdoor unit.
4. Thoroughly clean and flush, system of all debris. (see section 4.2 for instruction.)
5. Fill cylinder unit with potable water. Fill primary heating circuit with water and suitable anti-freeze and inhibitor as necessary. **Always use a filling loop with double check valve when filling the primary circuit to avoid back flow contamination of water supply.**

- Anti-freeze should always be used for packaged model systems (see section 4.2 for instruction). It is the responsibility of the installer to decide if anti-freeze solution should be used in split model systems depending on each site's conditions. Corrosion inhibitor should be used in both split model and packaged model systems. Figure 4.3.3 shows freezing temperature against anti-freeze concentration. This figure is an example for FERNOX ALPHI-11. For other anti-freeze, please refer to relevant manual.
- When connecting metal pipes of different materials insulate the joints to prevent a corrosive reaction taking place which will damage the pipework.

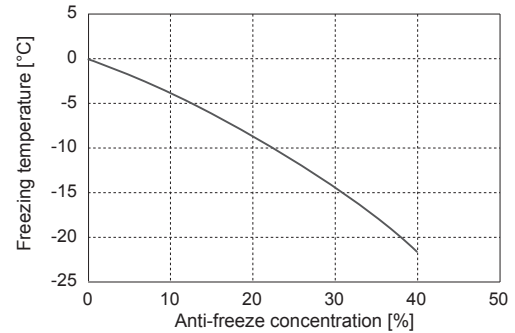

<Figure 4.3.3>

6. Check for leakages. If leakage is found, retighten the nut onto the connections.
7. Pressurise system to 1 bar.
8. Release all trapped air using air vents during and following heating period.
9. Top up with water as necessary. (If pressure is below 1 bar)

■ Sizing Expansion Vessels

Expansion vessel volume must fit the local system water volume.

To size an expansion vessel for the heating circuit the following formula and graph can be used.

When the necessary expansion vessel volume exceeds the volume of a built-in expansion vessel, install an additional expansion vessel so that the sum of the volumes of the expansion vessels exceeds the necessary expansion vessel volume.

* For installation of an E*ST20*-M*EC model, provide and install an expansion vessel in the field as the model does not come fitted with an expansion vessel.

$$V = \frac{\varepsilon \times G}{1 - \frac{P_1 + 0.098}{P_2 + 0.098}}$$

Where;

- V : Necessary expansion vessel volume [L]
- ε : Water expansion coefficient
- G : Total volume of water in the system [L]
- P₁ : Expansion vessel setting pressure [MPa]
- P₂ : Max. pressure during operation [MPa]

Graph to the right is for the following values

- ε : at 70 °C = 0.0229
- P₁ : 0.1 MPa
- P₂ : 0.3 MPa
- *A 30% safety margin has been added.

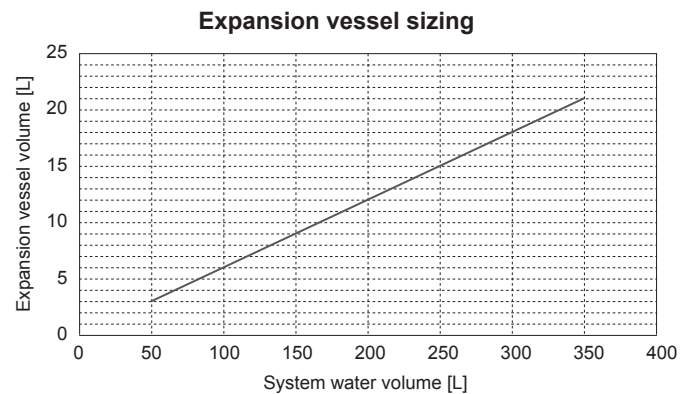

<Figure 4.3.4>

4 Installation

Water Circulation Pump Characteristics

1. Primary circuit

Pump speed can be selected by main remote controller setting (see <Figure 4.3.5 to 4.3.7>).

Adjust the pump speed setting so that the flow rate in the primary circuit is appropriate for the outdoor unit installed (see Table 4.3.1). It may be necessary to add an additional pump to the system depending on the length and lift of the primary circuit.

For outdoor unit model not listed in the <Table 4.3.1>, refer to Water flow rate range in the specification table of outdoor unit Data Book. In such case, make sure that the flow rate is greater than 7.1 L/min and less than 27.7 L/min.

<Second pump >

If a second pump is required for the installation please read the following carefully. If a second pump is used in the system it can be positioned in 2 ways.

The position of the pump influences which terminal of the FTC the signal cable should be wired to. If the additional pump(s) have current greater than 1A please use appropriate relay. Pump signal cable can either be wired to TBO.1 1-2 or CNP1 but not both.

Option 1 (Space heating/cooling only)

If the second pump is being used for the heating circuit only then the signal cable should be wired to TBO.1 terminals 3 and 4 (OUT2). In this position the pump can be run at a different speed to the cylinder unit's in-built pump.

Option 2 (Primary circuit DHW and space heating/cooling)

If the second pump is being used in the primary circuit between the cylinder unit and the outdoor unit (Package system ONLY) then the signal cable should be wired to TBO.1 terminals 1 and 2 (OUT1). In this position the pump speed **MUST** match the speed of the cylinder unit's in-built pump.

Note: Refer to 5.2 Connecting inputs/outputs.

Outdoor heat pump unit	Water flow rate range [L/min]	
Packaged model	PUHZ-W50	7.1-14.3
	PUHZ-W85	10.0-25.8
	PUHZ-W112	14.4-27.7
	PUHZ-HW112	14.4-27.7
	PUHZ-HW140	17.9-27.7
Split model	SUHZ-SW45	7.1-12.9
	PUHZ-SW40	7.1-11.8
	PUHZ-SW50	7.1-17.2
	PUHZ-FRP71	11.5-22.9
	PUHZ-SW75	10.2-22.9
	PUHZ-SW100	14.4-27.7
	PUHZ-SW120	20.1-27.7
	PUHZ-SHW80	10.2-22.9
	PUHZ-SHW112	14.4-27.7
	PUHZ-SHW140	17.9-27.7
	PUMY-P112	17.9-27.7
PUMY-P125	17.9-27.7	
PUMY-P140	17.9-27.7	

<Table 4.3.1>

* If the water flow rate is less than 7.1 L/min, the flow rate error will be activated. If the water flow rate exceeds 27.7 L/min, the flow speed will be greater than 1.5 m/s, which could erode the pipes.

2. Sanitary circuit

Default setting: Speed 2

DHW circulation pump **MUST** be set to speed 2.

Water circulation pump characteristics

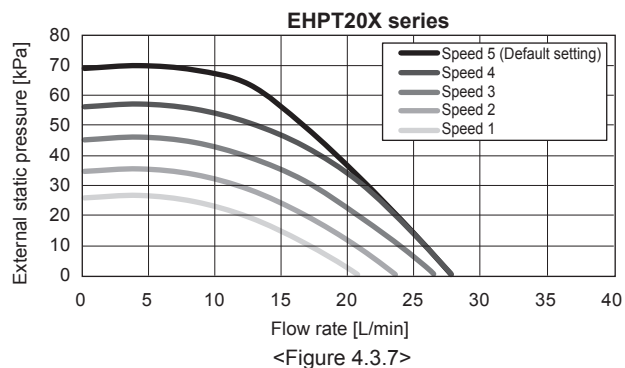
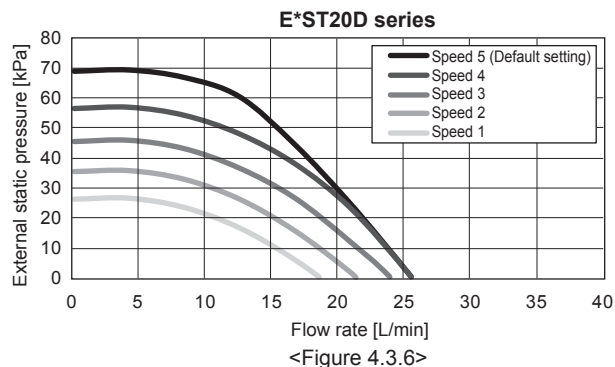
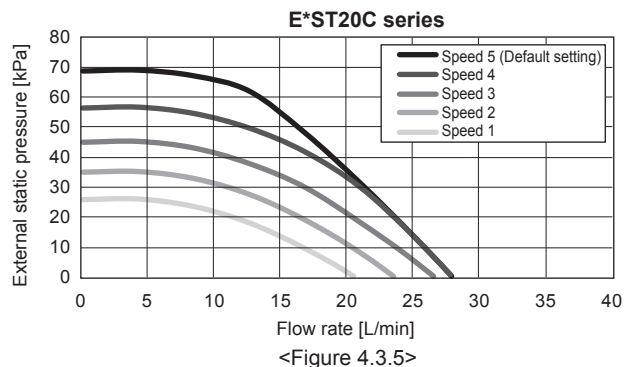

*For installation of EHPT20 series, set its pump speed with a pressure drop between the cylinder unit and the outdoor unit factored into the external static pressure.

4 Installation

■ Immersion heater

When an immersion heater is fitted, do NOT energise the heater until the DHW tank is full of water. Also do NOT energise any immersion heater if any sterilisation chemicals remain in the DHW tank as this will cause premature failure of the heater.

■ Safety Device Connections

The expansion relief valve on the secondary hot water side, and the temperature and pressure (T&P) relief valve (*1), both need appropriate discharge pipework.

*1 EHPT20X-MHCW, EHST20C-MHCW and EHST20D-MHCW are equipped with T & P relief valve, and any other models are equipped with Pressure relief valve.

Note : 1. Do not secure the screws excessively when connecting the Discharge pipe, otherwise it may result in damage to the cylinder unit.

<For UK>

The right side panel has a window (*2) so that connection can be made to the factory fitted temperature and pressure relief valve. If you wish to make the connection in a different position you will have to cut a hole in the side panel yourself. However it remains necessary that the drainage parameters outlined in the appropriate Building Regulations are complied with.

*2 Unscrew the plate on the right-side panel, connect the Pressure relief valve to the discharge pipework, and refit the plate. Always replace the plate so that no gaps exist between the plate and side panel and the plate and drain pipe to avoid heat loss.

In accordance with Building Regulations a tundish must be fitted into the pipe-work within 500 mm of the safety device (also see Figure 4.4.1). Due to the distance between the two safety devices it may be necessary to fit each safety device with its own tundish before you run the pipework together to a safe discharge (see Figure 4.3.8).

Note : 2. Alternatively the discharges from the expansion relief valve and T&P relief valve may commonly discharge to a singular tundish, so long as this tundish is located within 500 mm of the T&P relief valve in UK. When connecting discharge pipes to the safety devices, beware not to strain the inlet connections.

Diagram part No.	Description	Connection size	Connection type
1	Expansion relief valve (part of inlet control group)	15 mm	Compression
2	Pressure relief valve	G 1/2	Female
3	T&P relief valve	15 mm /G 1/2	Compression/ Female
4	Pressure relief valve	G 1/2	Female

<Table 4.3.2>

Always refer to local regulations when installing discharge pipework. Install discharge pipework in a frost-free environment. It is necessary to provide appropriate drainage from the pressure relief valve situated on top of the cylinder unit to prevent damage to the unit and the surrounding area from any steam or hot water released. Relief valves MUST NOT be used for any other purpose.

For UK use WK01UK-E kit, for other countries please see below;

- Any discharge pipework should be capable of withstanding discharge of hot water. Discharge pipework should be installed in a continuously downward direction. Discharge pipework must be left open to the environment.

■ Piping diagram for 2-zone temperature control

Connect the pipe work and locally supplied parts according to the relevant circuit diagram shown in Section 3. Technical Information, of this manual. For more details on wiring, refer to "5.3 Wiring for 2-zone temperature controls".

Note: Do not install the thermistors on the mixing tank. This could affect correct monitoring of flow and return temperatures through each zone. Install the Zone2 flow temp. thermistor (THW8) near the mixing valve.

<UK models>
EHPT20X-MHCW
EHST20C-MHCW
EHST20D-MHCW

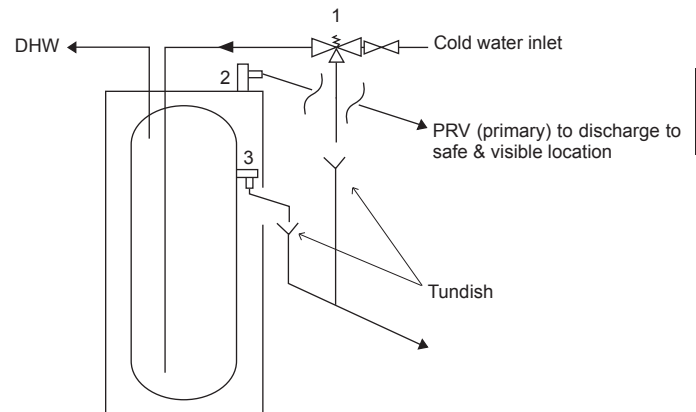

<Other models>

The expansion vessel on the sanitary water side shall be installed as necessary in accordance with your local regulations.

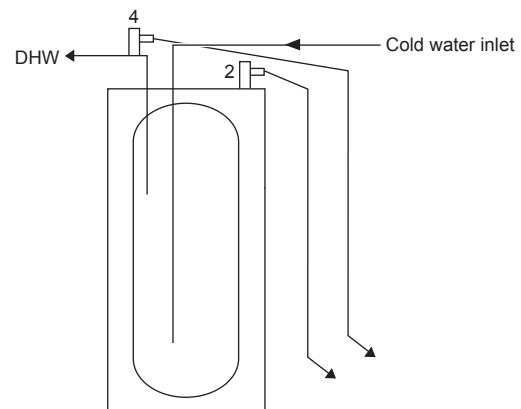

<Figure 4.3.8>

EN

4 Installation

4.4 Safety Device Discharge Arrangements (G3)

The following instructions are a requirement of UK Building Regulations and must be adhered to. For other countries please refer to local legislation. If you are in any doubt please seek advice from local building planning office.

1. Position the inlet control group so that discharge from both safety valves can be joined together via a 15 mm end feed Tee.
2. Connect the tundish and route the discharge pipe as shown in Figure 4.4.1.
3. The tundish should be fitted vertically and as close to the safety device as possible and within 500 mm of the device.
4. The tundish should be visible to occupants and positioned away from electrical devices.
5. The discharge pipe (D2) from the tundish should terminate in a safe place where there is no risk to persons in the vicinity of the discharge, be of metal construction and:

A) Be at least one pipe size larger than the nominal outlet size of the safety device unless its total equivalent hydraulic resistance exceeds that of a straight pipe 9 m long i.e. discharge pipes between 9 m and 18 m equivalent resistance length should be at least two sizes larger than the nominal outlet size of the safety device, between 18 and 27 m at least 3 sizes larger, and so on. Bends must be taken into account in calculating the flow resistance. Refer to Figure 4.4.1, Table 4.4.1 and the worked example. An alternative approach for sizing discharge pipes would be to follow BS 6700: 1987 specification for design installation, testing and maintenance of services supplying water for domestic use within buildings and their cartilages.

B) Have a vertical section of pipe at least 300 mm long, below the tundish before any elbows or bends in the pipework.

C) Be installed with a continuous fall.

D) Have discharges visible at both the tundish and the final point of discharge but where this is not possible or is practically difficult there should be clear visibility at one or other of these locations. Examples of acceptable discharge arrangements are:

- i. Ideally below a fixed grating and above the water seal in a trapped gully.
- ii. Downward discharges at low level; i.e. up to 100 mm above external surfaces such as car parks, hard standings, grassed areas etc. are acceptable providing that where children may play or otherwise come into contact with discharges a wire cage or similar guard is positioned to prevent contact, whilst maintaining visibility.
- iii. Discharges at high level; e.g. into a metal hopper and metal down pipe with the end of the discharge pipe clearly visible (tundish visible or not) or onto a roof capable of withstanding high temperature discharges of water and 3 m from any plastic guttering system that would collect such discharges (tundish visible).
- iv. Where a single pipe serves a number of discharges, such as in blocks of flats, the number served should be limited to not more than 6 systems so that any installation discharging can be traced reasonably easily. The single common discharge pipe should be at least one pipe size larger than the largest individual discharge pipe (D2) to be connected. If unvented hot water storage systems are installed where discharges from safety devices may not be apparent i.e. in dwellings occupied by blind, infirm or disabled people, consideration should be given to the installation of an electronically operated device to warn when discharge takes place.

Note: The discharge will consist of scalding water and steam. Asphalt, roofing felt and nonmetallic rainwater goods may be damaged by such discharges.

Worked example: The example below is for a G½ temperature relief valve with a discharge pipe (D2) having 4 No. elbows and length of 7 m from the tundish to the point of discharge.

From Table 4.4.1: Maximum resistance allowed for a straight length of 22 mm copper discharge pipe (D2) from a G½ temperature relief valve is: 9.0 m subtract the resistance for 4 No. 22 mm elbows at 0.8 m each = 3.2 m. Therefore the maximum permitted length equates to: 5.8 m. 5.8 m is less than the actual length of 7 m, therefore calculate the next largest size. Maximum resistance allowed for a straight length of 28 mm pipe (D2) from a G½ temperature relief valve equates to: 18 m
 Subtract the resistance for 4 No. 28 mm elbows at 1.0 m each = 4 m. Therefore the maximum permitted length equates to: 14 m. As the actual length is 7 m, a 28 mm (D2) copper pipe will be satisfactory.

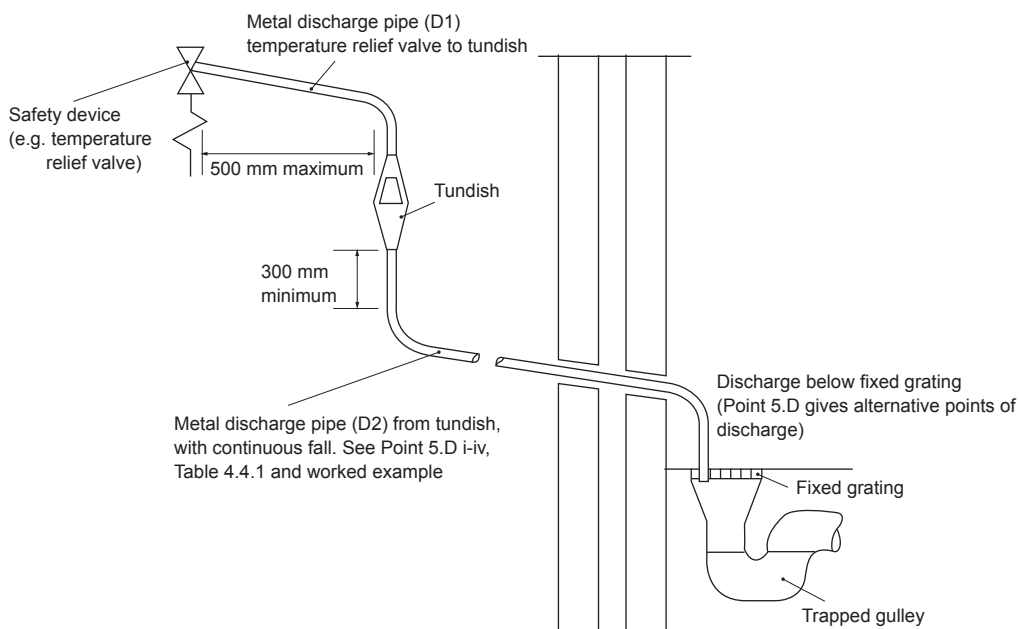

<Figure 4.4.1>

Valve outlet size	Minimum size of discharge pipe D1	Minimum size of discharge pipe D2 from tundish	Maximum resistance allowed, expressed as a length of straight pipe (no elbows or bends)	Resistance created by each elbow or bend
G 1/2	15 mm	22 mm	Up to 9 m	0.8 m
		28 mm	Up to 18 m	1.0 m
		35 mm	Up to 27 m	1.4 m
G 3/4	22 mm	28 mm	Up to 9 m	1.0 m
		35 mm	Up to 18 m	1.4 m
		42 mm	Up to 27 m	1.7 m
G1	28 mm	35 mm	Up to 9 m	1.4 m
		42 mm	Up to 18 m	1.7 m
		54 mm	Up to 27 m	2.3 m

<Table 4.4.1>

4 Installation

4.5 Electrical Connection

All electrical work should be carried out by a suitably qualified technician. Failure to comply with this could lead to electrocution, fire, and death. It will also invalidate product warranty. All wiring should be according to national wiring regulations.

Breaker abbreviation	Meaning
ECB1	Earth leakage circuit breaker for booster heater
ECB2	Earth leakage circuit breaker for immersion heater
TB1	Terminal block 1

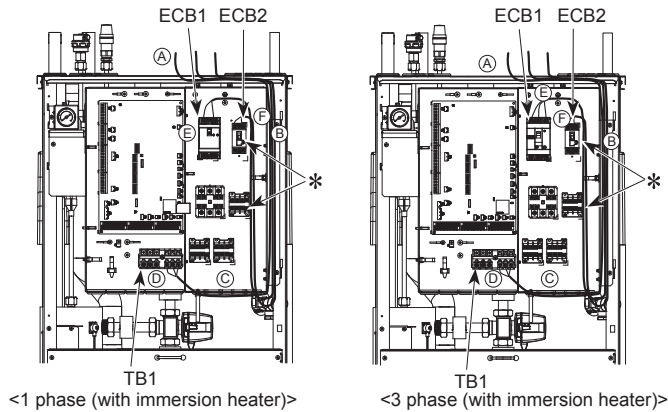

The cylinder unit can be powered in two ways.

1. Power cable is run from the outdoor unit to the cylinder unit.
2. Cylinder unit has independent power source

Connections should be made to the terminals indicated in the figures to the left below depending on the phase.

Booster heater and immersion heater should be connected independently from one another to dedicated power supplies.

- Locally supplied wiring should be inserted through the inlets situated on the top of the cylinder unit. (Refer to <Table 3.3>.)
- Wiring should be fed down the right hand side of the control and electrical box and clamped in place using clips provided.
- The wires should be inserted individually through the cable inlets as below.
 - Outputs wire
 - Signal input wire
 - Wireless receiver (option) wire (PAR-WR51R-E)
 - 7⑨ and ⑩ Power line and indoor-outdoor wire
- Connect the outdoor unit – cylinder unit connecting cable to TB1.
- Connect the power cable for the booster heater to ECB1.
- If immersion heater is present, connect the power cable to ECB2.

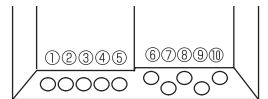

- Avoid contact between wiring and parts (*).
- Make sure that ECB1 and ECB2 are ON.
- On completion of wiring ensure main remote controller cable is connected to the relay connector.

Option 1: Cylinder unit powered via outdoor unit <1 phase>

Affix label A that is included with the manuals near each wiring diagram for cylinder unit and outdoor units.

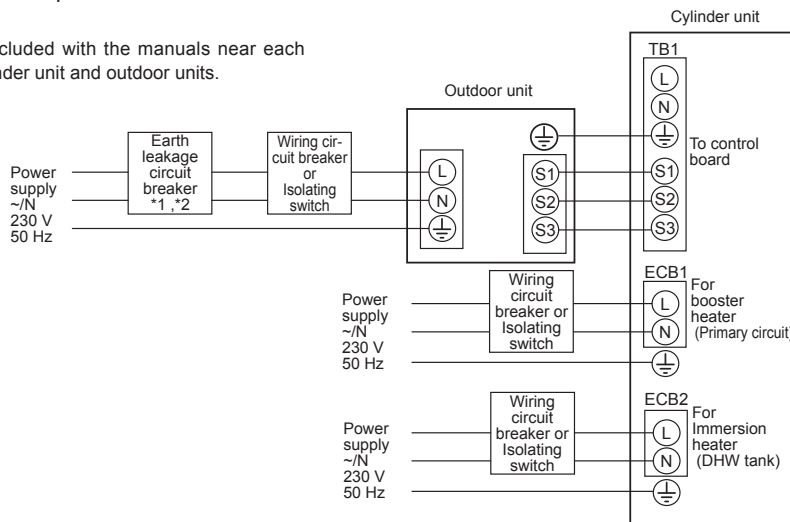

*1 If the installed earth leakage circuit breaker does not have an over-current protection function, install a breaker with that function along the same power line.

<Figure 4.5.1> Electrical connections 1 phase

Description	Power supply	Capacity	Breaker	Wiring
Booster heater (Primary circuit)	~N 230 V 50 Hz	2 kW	16 A *2	2.5 mm ²
		6 kW	32 A *2	6.0 mm ²
Immersion heater (DHW tank)	~N 230 V 50 Hz	3 kW	16 A *2	2.5 mm ²

Wiring No. x size (mm ²)	Cylinder unit - Outdoor unit		
	Cylinder unit - Outdoor unit	*3	3 × 1.5 (polar)
Cylinder unit - Outdoor unit earth	*3	1 × Min. 1.5	
Circuit rating	Cylinder unit - Outdoor unit S1 - S2	*4	230 V AC
	Cylinder unit - Outdoor unit S2 - S3	*4	24 V DC

*2. A breaker with at least 3.0 mm contact separation in each pole shall be provided. Use earth leakage breaker (NV). The breaker shall be provided to ensure disconnection of all active phase conductors of the supply.

*3. Max. 45 m
If 2.5 mm² used, Max. 50 m
If 2.5 mm² used and S3 separated, Max. 80 m

*4. The values given in the table above are not always measured against the ground value.

- Note:**
1. Wiring size must comply with the applicable local and national codes.
 2. Indoor unit/outdoor unit connecting cords shall not be lighter than polychloroprene sheathed flexible cord. (Design 60245 IEC 57)
 3. Indoor unit power supply cords shall not be lighter than polychloroprene sheathed flexible cord. (Design 60227 IEC 53)
 3. Install an earth longer than other cables.
 4. Please keep enough output capacity of power supply for each heater. Insufficient power supply capacity might cause chattering.

4 Installation

<3 phase>

Affix label A that is included with the manuals near each wiring diagram for cylinder unit and outdoor units.

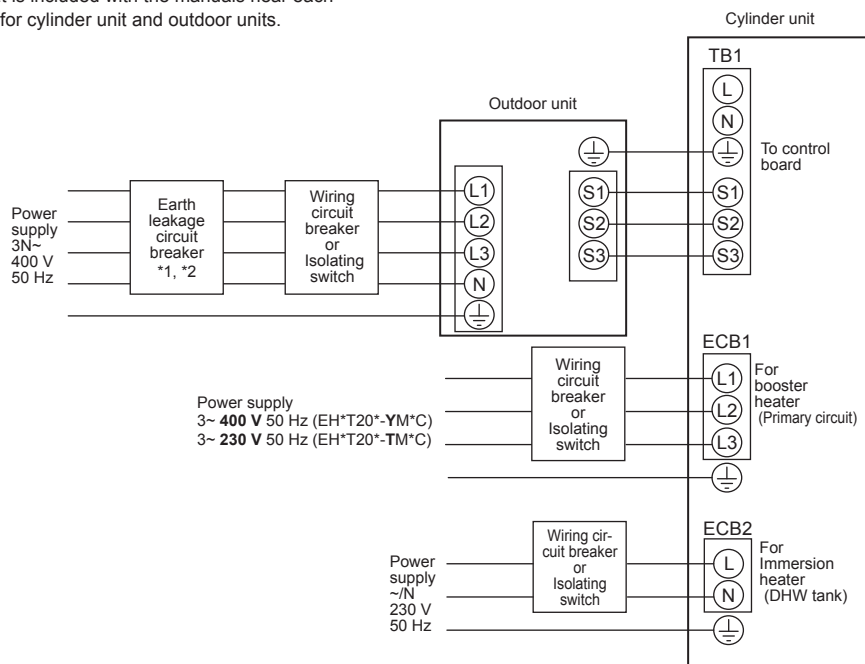

*1 If the installed earth leakage circuit breaker does not have an over-current protection function, install a breaker with that function along the same power line.

<Figure 4.5.2>
Electrical connections 3 phase

Description	Power supply	Capacity (Indoor unit Ref.)	Breaker	Wiring
Booster heater (Primary circuit)	3~ 400 V 50 Hz	9 kW	16 A *2	2.5 mm ²
	3~ 230 V 50 Hz	9 kW	32 A *2	6.0 mm ²
Immersion heater (DHW tank)	~N 230 V 50 Hz	3 kW	16 A *2	2.5 mm ²

Wiring Wiring No. x size (mm ²)	Cylinder unit - Outdoor unit	*3	3 × 1.5 (polar)
	Cylinder unit - Outdoor unit earth	*3	1 × Min. 1.5
Circuit rating	Cylinder unit - Outdoor unit S1 - S2	*4	230 V AC
	Cylinder unit - Outdoor unit S2 - S3	*4	24 V DC

*2. A breaker with at least 3.0 mm contact separation in each pole shall be provided. Use earth leakage breaker (NV). The breaker shall be provided to ensure disconnection of all active phase conductors of the supply.

*3. Max. 45 m

If 2.5 mm² used, Max. 50 m

If 2.5 mm² used and S3 separated, Max. 80 m

*4. The values given in the table above are not always measured against the ground value.

- Note:**
1. Wiring size must comply with the applicable local and national codes.
 2. Indoor unit/outdoor unit connecting cords shall not be lighter than polychloroprene sheathed flexible cord. (Design 60245 IEC 57)
Indoor unit power supply cords shall not be lighter than polychloroprene sheathed flexible cord. (Design 60227 IEC 53)
 3. Install an earth longer than other cables.
 4. Please keep enough output capacity of power supply for each heater. Insufficient power supply capacity might cause chattering.

4 Installation

Option 2: Cylinder unit powered by independent source.

If the cylinder unit and outdoor unit have separate power supplies, the following requirements MUST be carried out:

- Change the interconnected wiring in the control and electrical box of the cylinder unit (see Figure 4.5.3)
- Turn the outdoor unit DIP switch SW8-3 to ON
- Turn on the outdoor unit BEFORE the cylinder unit.
- Power by independent source is not available for particular models of outdoor unit model. For more detail, refer to the connecting outdoor unit Installation Manual.

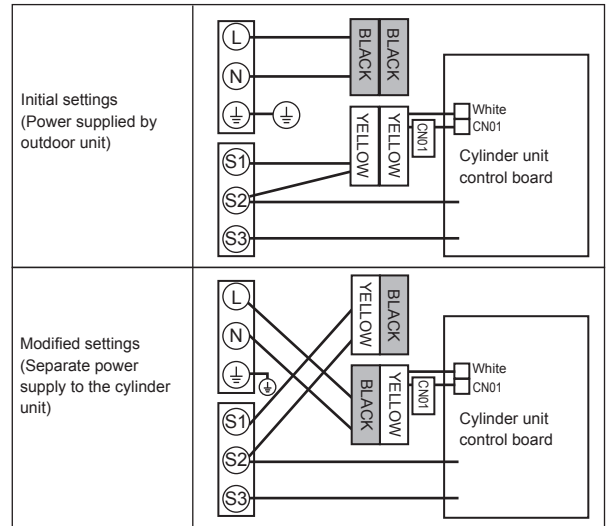

<Figure 4.5.3>

<1 phase>

Affix label B that is included with the manuals near each wiring diagram for cylinder unit and outdoor units.

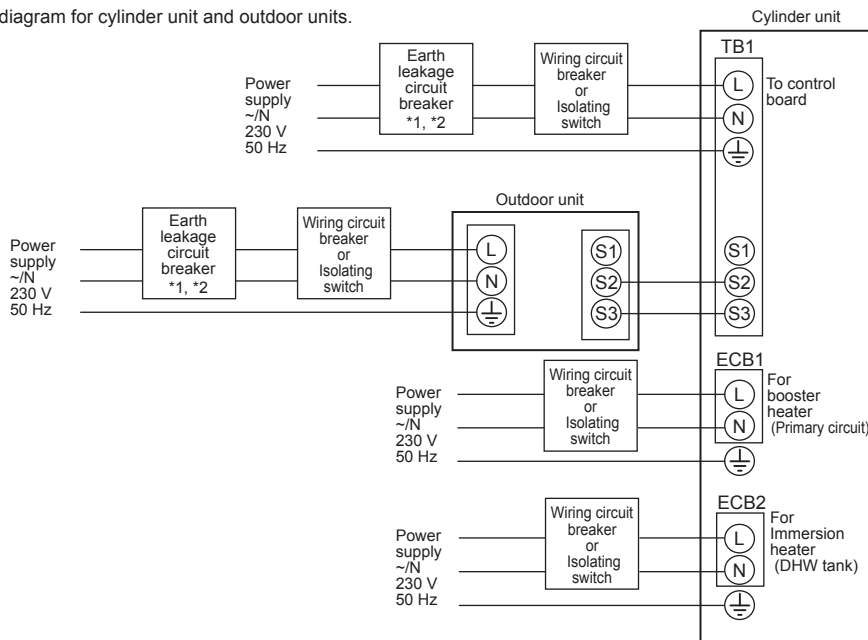

*1 If the installed earth leakage circuit breaker does not have an over-current protection function, install a breaker with that function along the same power line.

<Figure 4.5.4>
Electrical connections 1 phase

Description	Power supply	Capacity	Breaker	Wiring
Booster heater (Primary circuit)	~N 230 V 50 Hz	2 kW	16 A *2	2.5 mm ²
		6 kW	32 A *2	6.0 mm ²
Immersion heater (DHW tank)	~N 230 V 50 Hz	3 kW	16 A *2	2.5 mm ²

Cylinder unit power supply		~N 230 V 50 Hz
Cylinder unit input capacity		*2
Main switch (Breaker)		16 A
Wiring No. × size (mm ²)	Cylinder unit power supply	2 × Min. 1.5
	Cylinder unit power supply earth	1 × Min. 1.5
	Cylinder unit - Outdoor unit	*3
	Cylinder unit - Outdoor unit earth	—
Circuit rating	Cylinder unit L - N	*4
	Cylinder unit - Outdoor unit S1 - S2	*4
	Cylinder unit - Outdoor unit S2 - S3	*4

*2. A breaker with at least 3.0 mm contact separation in each pole shall be provided. Use earth leakage breaker (NV). The breaker shall be provided to ensure disconnection of all active phase conductors of the supply.

*3. Max. 120 m

*4. The values given in the table above are not always measured against the ground value.

- Note:**
1. Wiring size must comply with the applicable local and national codes.
 2. Indoor unit/outdoor unit connecting cords shall not be lighter than polychloroprene sheathed flexible cord. (Design 60245 IEC 57)
Indoor unit power supply cords shall not be lighter than polychloroprene sheathed flexible cord. (Design 60227 IEC 53)
 3. Install an earth longer than other cables.
 4. Please keep enough output capacity of power supply for each heater. Insufficient power supply capacity might cause chattering.

4 Installation

<3 phase>

Affix label B that is included with the manuals near each wiring diagram for cylinder unit and outdoor units.

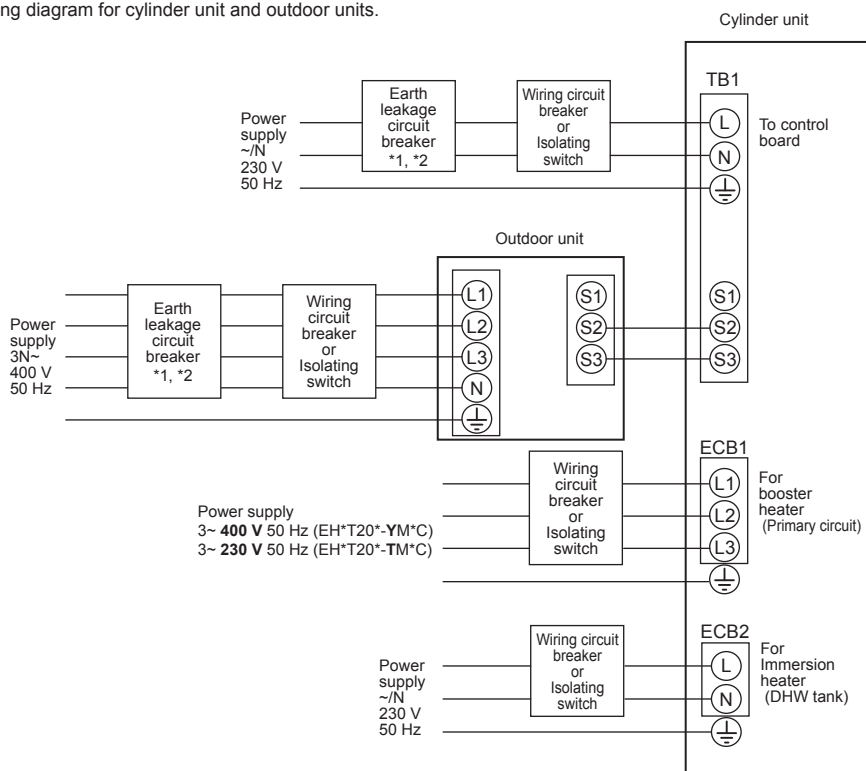

*1 If the installed earth leakage circuit breaker does not have an over-current protection function, install a breaker with that function along the same power line.

<Figure 4.5.5>
Electrical connections 3 phase

Description	Power supply	Capacity (Indoor unit Ref.)	Breaker	Wiring
Booster heater (Primary circuit)	3~ 400 V 50 Hz	9 kW	16 A *2	2.5 mm ²
	3~ 230 V 50 Hz	9 kW	32 A *2	6.0 mm ²
Immersion heater (DHW tank)	~N 230 V 50 Hz	3 kW	16 A *2	2.5 mm ²

Cylinder unit power supply		~N 230 V 50 Hz
Cylinder unit input capacity		*2
Main switch (Breaker)		16 A
Wiring No. x size (mm ²)	Cylinder unit power supply	2 x Min. 1.5
	Cylinder unit power supply earth	1 x Min. 1.5
	Cylinder unit - Outdoor unit	*3
	Cylinder unit - Outdoor unit earth	2 x Min. 0.3
Circuit rating	Cylinder unit L - N	*4
	Cylinder unit - Outdoor unit S1 - S2	*4
	Cylinder unit - Outdoor unit S2 - S3	*4
		24 V DC

*2. A breaker with at least 3.0 mm contact separation in each pole shall be provided. Use earth leakage breaker (NV).

The breaker shall be provided to ensure disconnection of all active phase conductors of the supply.

*3. Max. 120 m

*4. The values given in the table above are not always measured against the ground value.

- Note:**
1. Wiring size must comply with the applicable local and national codes.
 2. Indoor unit/outdoor unit connecting cords shall not be lighter than polychloroprene sheathed flexible cord. (Design 60245 IEC 57)
Indoor unit power supply cords shall not be lighter than polychloroprene sheathed flexible cord. (Design 60227 IEC 53)
 3. Install an earth longer than other cables.
 4. Please keep enough output capacity of power supply for each heater. Insufficient power supply capacity might cause chattering.

5 System Set Up

5.1 DIP Switch Functions

Located on the FTC printed circuit board are 5 sets of small white switches known as DIP switches. The DIP switch number is printed on the circuit board next to the relevant switches. The word ON is printed on the circuit board and on the DIP switch block itself. To move the switch you will need to use a pin or the corner of a thin metal ruler or similar.

DIP switch settings are listed below in Table 5.1.1. Only an authorised installer can change DIP switch setting under one's own responsibility according to the installation condition. Make sure to turn off both indoor unit and outdoor unit power supplies before changing the switch settings.

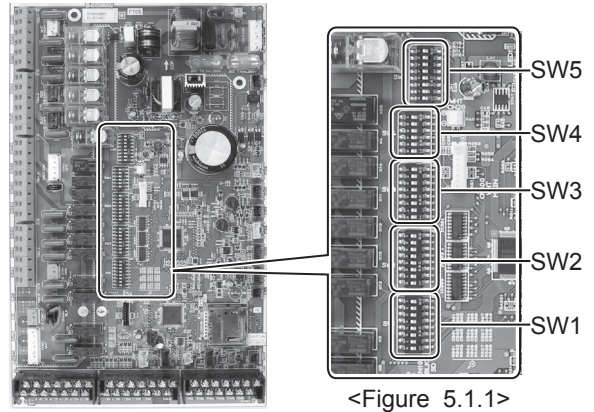

<Figure 5.1.1>

DIP switch	Function	OFF	ON	Default settings: Indoor unit model			
SW1	SW1-1 Boiler	WITHOUT Boiler	WITH Boiler	OFF			
	SW1-2 Heat pump maximum outlet water temperature	55°C	60°C	ON *1			
	SW1-3 DHW tank	WITHOUT DHW tank	WITH DHW tank	ON			
	SW1-4 Immersion heater	WITHOUT Immersion heater	WITH Immersion heater	OFF: E**T20*-*C ON : EH*T20*-*HC*			
	SW1-5 Booster heater	WITHOUT Booster heater	WITH Booster heater	OFF: E**T20*-*M*C* ON : E**T20*-*M 2/6/9°C			
	SW1-6 Booster heater function	For heating only	For heating and DHW	OFF: E**T20*-*M*C* ON : E**T20*-*M 2/6/9°C			
	SW1-7 Outdoor unit type	Split type	Packaged type	OFF: E*ST20*-*M**C* ON : EHPT20X-*M**C*			
	SW1-8 Wireless remote controller	WITHOUT Wireless remote controller	WITH Wireless remote controller	OFF			
SW2	SW2-1 Room thermostat1 input (IN1) logic change	Zone1 operation stop at thermostat short	Zone1 operation stop at thermostat open	OFF			
	SW2-2 Flow switch1 input (IN2) logic change	Failure detection at short	Failure detection at open	OFF			
	SW2-3 Booster heater capacity restriction	Inactive	Active	OFF: Except EH*T20*-VM2°C ON : EH*T20*-VM2°C			
	SW2-4 Cooling mode function	Inactive	Active	OFF: EH*T20*-*M**C* ON : ERST20*-*M**C			
	SW2-5 Automatic switch to backup heat source operation (When outdoor unit stops by error)	Inactive	Active *2	OFF			
	SW2-6 Mixing tank	WITHOUT Mixing tank	WITH Mixing tank	OFF			
	SW2-7 2-zone temperature control	Inactive	Active *6	OFF			
	SW2-8 Flow sensor	WITHOUT Flow sensor	WITH Flow sensor	ON			
SW3	SW3-1 Room thermostat 2 input (IN6) logic change	Zone2 operation stop at thermostat short	Zone2 operation stop at thermostat open	OFF			
	SW3-2 Flow switch 2 input (IN3) logic change	Failure detection at short	Failure detection at open	OFF			
	SW3-3 Flow switch 3 input (IN7) logic change	Failure detection at short	Failure detection at open	OFF			
	SW3-4 Electric energy meter	WITHOUT Electric energy meter	WITH Electric energy meter	OFF			
	SW3-5 Heating mode function *3	Inactive	Active	ON			
	SW3-6 2-zone valve ON/OFF control	Inactive	Active	OFF			
	SW3-7 Heat exchanger for DHW	Coil in tank	External plate HEX	ON			
	SW3-8 Heat meter	WITHOUT Heat meter	WITH Heat meter	OFF			
SW4	SW4-1	—	—	OFF			
	SW4-2	—	—	OFF			
	SW4-3	—	—	OFF			
	SW4-4 Indoor unit only operation (during installation work) *4	Inactive	Active	OFF			
	SW4-5 Emergency mode (Heater only operation)	Normal	Emergency mode (Heater only operation)	OFF *5			
	SW4-6 Emergency mode (Boiler operation)	Normal	Emergency mode (Boiler operation)	OFF *5			
SW5	SW5-1	—	—	OFF			
	SW5-2 Advanced auto adaptation	Inactive	Active	ON			
	SW5-3	Capacity code					
	SW5-4		SW5-3	SW5-4	SW5-5	SW5-6	SW5-7
	SW5-5	E*ST20C-*M*C*	ON	ON	ON	ON	OFF
	SW5-6	E*ST20D-*M*C*	ON	OFF	OFF	ON	OFF
	SW5-7	EHPT20X-*M*C*	OFF	OFF	OFF	OFF	OFF
	SW5-8	—	—	—	—	—	OFF

<Table 5.1.1>

- Note:
- *1. When the cylinder unit is connected with a PUMY-P/SUHZ-SW outdoor unit of which maximum outlet water temperature is 55°C, DIP SW1-2 must be changed to OFF.
 - *2. External output (OUT11) will be available. For safety reasons, this function is not available for certain errors. (In that case, system operation must be stopped and only the water circulation pump keeps running.)
 - *3. This switch functions only when the cylinder unit is connected with a PUHZ-FRP outdoor unit. When another type of outdoor unit is connected, the heating mode function is active regardless of the fact that this switch is ON or OFF.
 - *4. Space heating and DHW can be operated only in indoor unit, like an electric boiler. (Refer to "5.5 Indoor unit only operation".)
 - *5. If emergency mode is no longer required, return the switch to OFF position.
 - *6. Active only when SW3-6 is set to OFF.

5 System Set Up

5.2 Connecting inputs/outputs

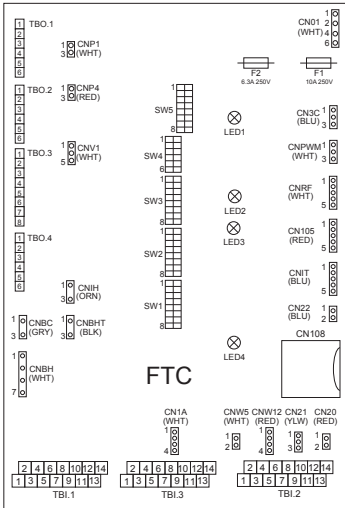

When the wires are wired to adjacent terminals use ring terminals and insulate the wires.

<Figure 5.2.1>

Signal inputs

Name	Terminal block	Connector	Item	OFF (Open)	ON (Short)
IN1	TBI.1 13-14	—	Room thermostat 1 input *1	Refer to SW2-1 in <5.1 DIP Switch Functions>.	
IN2	TBI.1 11-12	—	Flow switch 1 input	Refer to SW2-2 in <5.1 DIP Switch Functions>.	
IN3	TBI.1 9-10	—	Flow switch 2 input (Zone1)	Refer to SW3-2 in <5.1 DIP Switch Functions>.	
IN4	TBI.1 7-8	—	Demand control input	Normal	Heat source OFF/ Boiler operation *3
IN5	TBI.1 5-6	—	Outdoor thermostat input *2	Standard operation	Heater operation/ Boiler operation *3
IN6	TBI.1 3-4	—	Room thermostat 2 input *1	Refer to SW3-1 in <5.1 DIP Switch Functions>.	
IN7	TBI.1 1-2	—	Flow switch 3 input (Zone2)	Refer to SW3-3 in <5.1 DIP Switch Functions>.	
IN8	TBI.3 1-2	—	Electric energy meter 1	*4	
IN9	TBI.3 3-4	—	Electric energy meter 2		
IN10	TBI.3 5-6	—	Heat meter	*5	
IN11	TBI.3 7-8	—	Smart grid ready input		
IN12	TBI.3 9-10	—			
IN1A	TBI.3 12-14	CN1A	Flow sensor	—	—

*1. Set the ON/OFF cycle time of the room thermostat for 10 minutes or more; otherwise the compressor may be damaged.

*2. If using outdoor thermostat for controlling operation of heaters, the lifetime of the heaters and related parts may be reduced.

*3. To turn on the boiler operation, use the main remote controller to select "Boiler" in "External input setting" screen in the service menu.

*4. Connectable electric energy meter and heat meter

- Pulse type Voltage free contact for 12VDC detection by FTC (TBI.3 1, 3 and 5 pins have a positive voltage.)
- Pulse duration Minimum ON time: 40ms
Minimum OFF time: 100ms
- Possible unit of pulse 0.1 pulse/kWh 1 pulse/kWh 10 pulse/kWh
100 pulse/kWh 1000 pulse/kWh

Those values can be set by the main remote controller. (Refer to the menu tree in "5.9 Main remote controller".)

*5. As for the SG ready, refer to "5.6 Smart grid ready".

Wiring specification and local supply parts

Item	Name	Model and specifications
Signal input function	Signal input wire	Use sheathed vinyl coated cord or cable. Max. 30 m Wire type: CV, CVS or equivalent Wire size: Stranded wire 0.13 mm ² to 1.25 mm ² Solid wire: ø0.4 mm to ø1.2 mm
	Switch	Non-voltage "a" contact signals Remote switch: minimum applicable load 12V DC, 1mA

Thermistor inputs

Name	Terminal block	Connector	Item	Optional part model
TH1	—	CN20	Thermistor (Room temp.) (Option)	PAC-SE41TS-E
TH2	—	CN21	Thermistor (Ref. liquid temp.)	—
THW1	—	CNW12 1-2	Thermistor (Flow water temp.)	—
THW2	—	CNW12 3-4	Thermistor (Return water temp.)	—
THW5	—	CNW5	Thermistor (DHW tank water temp.)	—
THW6	TBI.2 3-4	—	Thermistor (Zone1 flow water temp.) (Option) *1	PAC-TH011-E
THW7	TBI.2 5-6	—	Thermistor (Zone1 return water temp.) (Option) *1	
THW8	TBI.2 7-8	—	Thermistor (Zone2 flow water temp.) (Option) *1	PAC-TH011-E
THW9	TBI.2 9-10	—	Thermistor (Zone2 return water temp.) (Option) *1	
THWB1	TBI.2 11-12	—	Thermistor (Boiler flow water temp.) (Option) *1	PAC-TH011HT-E
THWB2	TBI.2 13-14	—	Thermistor (Boiler return water temp.) (Option) *1	

Ensure to wire thermistor wirings away from the power line and/or OUT1 to 15 wirings.

*1. The maximum length of the thermistor wiring is 30 m. When the wires are wired to adjacent terminals, use ring terminals and insulate the wires.

The length of the optional thermistors are 5 m. If you need to splice and extend the wirings, following points must be carried out.

- 1) Connect the wirings by soldering.
- 2) Insulate each connecting point against dust and water.

5 System Set Up

■ Outputs

Name	Terminal block	Connector	Item	OFF	ON	Signal/Max current	Max. total current
OUT1	TBO.1 1-2	CNP1	Water circulation pump 1 output (Space heating/cooling & DHW)	OFF	ON	230V AC 1.0A Max.	4.0A (a)
OUT2	TBO.1 3-4	—	Water circulation pump 2 output (Space heating/cooling for Zone1)	OFF	ON	230V AC 1.0A Max.	
OUT3	TBO.1 5-6	—	Water circulation pump 3 output (Space heating/cooling for Zone2) *1 2-way valve 2b output *2	OFF	ON	230V AC 1.0A Max.	
OUT14	—	CNP4	Water circulation pump 4 output (DHW)	OFF	ON	230V AC 1.0A Max.	3.0A (b)
OUT4	TBO.2 4-6	CNV1	3-way valve output	Heating	DHW	230V AC 0.1A Max.	
OUT5	TBO.2 1-2 TBO.2 2-3	—	Mixing valve output *1	Stop	Close Open	230V AC 0.1A Max.	
OUT6	—	CNBH 1-3	Booster heater 1 output	OFF	ON	230V AC 0.5A Max. (Relay)	
OUT7	—	CNBH 5-7	Booster heater 2 output	OFF	ON	230V AC 0.5A Max. (Relay)	
OUT8	TBO.4 5-6	—	Cooling signal output	OFF	ON	230V AC 0.5A Max.	
OUT9	TBO.4 3-4	CNIH	Immersion heater output	OFF	ON	230V AC 0.5A Max. (Relay)	
OUT11	TBO.3 3-4	—	Error output	Normal	Error	230V AC 0.5A Max.	
OUT12	TBO.3 5-6	—	Defrost output	Normal	Defrost	230V AC 0.5A Max.	
OUT13	TBO.4 1-2	—	2-way valve 2a output *2	OFF	ON	230V AC 0.1A Max.	
OUT15	TBO.3 7-8	—	Comp ON signal	OFF	ON	230V AC 0.5A Max.	
OUT10	TBO.3 1-2	—	Boiler output	OFF	ON	non-voltage contact ·220-240V AC (30V DC) ·0.5A or less ·10mA 5V DC or more	—

Do not connect to the terminals that are indicated as “—” in the “Terminal block” field.

*1 For 2-zone temperature control.

*2 For 2-zone valve ON/OFF control.

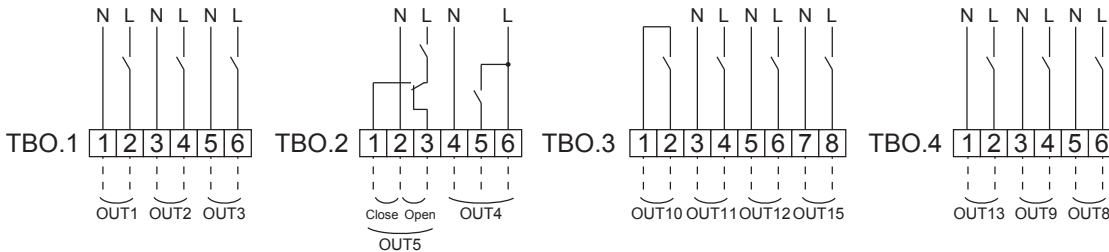

How to use TBO.1 to 4

Wiring specification and local supply parts

Item	Name	Model and specifications
External output function	Outputs wire	Use sheathed vinyl coated cord or cable. Max. 30 m Wire type: CV, CVS or equivalent Wire size: Stranded wire 0.25 mm ² to 1.5 mm ² Solid wire: ø0.57 mm to ø1.2 mm

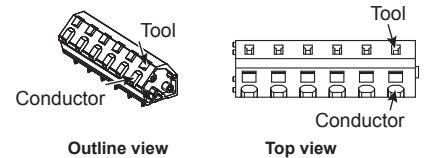

Connect them using either way as shown above.

<Figure 5.2.2>

- Note:**
- When the cylinder unit is powered via outdoor unit, the maximum grand total current of (a)+(b) is 3.0 A.
 - Do not connect multiple water circulation pumps directly to each output (OUT1, OUT2, and OUT3). In such a case, connect them via (a) relay(s).
 - Do not connect water circulation pumps to both TBO.1 1-2 and CNP1 at the same time.
 - Connect an appropriate surge absorber to OUT10 (TBO.3 1-2) depending on the load at site.
 - Stranded wire should be processed with insulation-covered bar terminal (DIN46228-4 standard compatible type).

5.3 Wiring for 2-zone temperature control

- Water circulation pump 2 (Zone1 water circulation pump) / Water circulation pump 3 (Zone2 water circulation pump)
Electrically wire water circulation pumps 2 and 3 to the appropriate output terminals. (Refer to “Outputs” in 5.2.)
- Flow switch 2 (Zone1 flow switch) / Flow switch 3 (Zone2 flow switch)
Connect flow switches 2 and 3 to the appropriate terminals. (Refer to “Signal inputs” in 5.2.)
Set DIP switches 3-2 and 3-3 according to the functions of individual flow switches 2 and 3. (Refer to “DIP switch functions” in 5.1.)
- Thermistor
Connect the thermistor to monitor the Zone1 flow temperature to the THW6 (TBI. 2-3 and 2-4) terminals.
Connect the thermistor to monitor the Zone1 return temperature to the THW7 (TBI. 2-5 and 2-6) terminals.
Connect the thermistor to monitor the Zone2 flow temperature to the THW8 (TBI. 2-7 and 2-8) terminals.
Connect the thermistor to monitor the Zone2 return temperature to the THW9 (TBI. 2-9 and 2-10) terminals.

The maximum length of the thermistor wiring is 30 m. The length of the optional thermistors are 5 m. If you need to splice and extend the wirings, following points must be carried out.

- Connect the wirings by soldering.
 - Insulate each connecting point against dust and water.
- Motorized mixing valve
Connect three wires coming from the motorized mixing valve to the appropriate terminals referring to “Outputs” in 5.2.

Note: Connect the signal line to open Port A (hot water inlet port) to TBO. 2-3 (Open), the signal line to open Port B (cold water inlet port) to TBO. 2-1 (Close), and the neutral terminal wire to TBO. 2-2 (N).

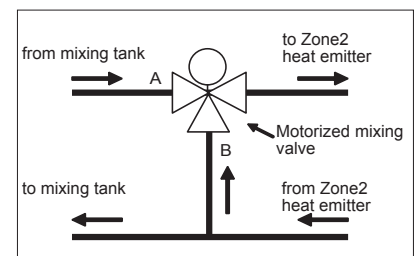
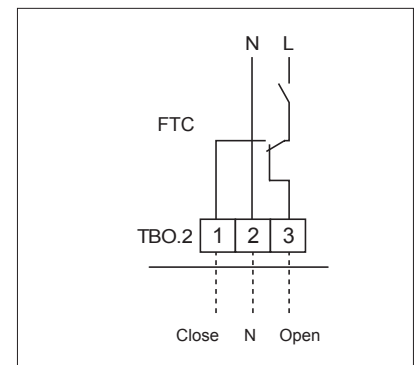

5 System Set Up

5.4 2-zone valve ON/OFF control

Opening /closing 2-way valve provides a simple 2-Zone control.
Flow temperature is common for Zone1 and 2.

1. Pipe work

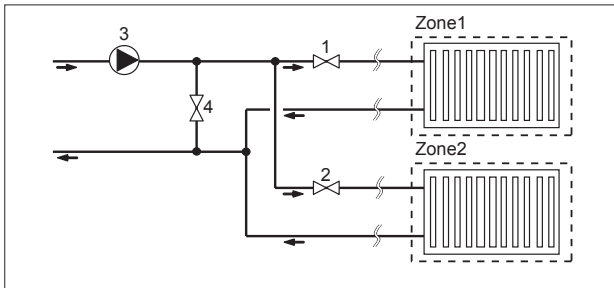

1. Zone1 2-way valve 2a (local supply)
2. Zone2 2-way valve 2b (local supply)
3. Water circulation pump 2 (local supply) *1
4. By-pass valve (local supply) *2

*1 Install according to system in the field.
*2 For safety protection, it is recommended to install a by-pass valve.

Note: Freeze stat function is deactivated whilst this control is ON. Use anti-freeze solution to avoid freezing, if necessary.

2. DIP switch

Turn DIP switch 3-6 ON.

3. 2-way valve 2a (for Zone1) / 2-way valve 2b (for Zone2)

Electrically wire 2-way valve 2a and 2b to the appropriate external output terminals. (Refer to "External outputs" in 5.2)

4. Room thermostat connection

Heating operation mode	Zone1	Zone2
Room temp. control (Auto adaptation) *3	<ul style="list-style-type: none"> ●Wireless remote controller (option) ●Room temperature thermistor (option) ●Main remote controller (remote position) 	<ul style="list-style-type: none"> ●Wireless remote controller (option)
Compensation curve or flow temp. control	<ul style="list-style-type: none"> ●Wireless remote controller (option) *4 ●Room temperature thermostat (local supply) 	<ul style="list-style-type: none"> ●Wireless remote controller (option) *4 ●Room temperature thermostat (local supply)

*3 Ensure to install the room thermostat for Zone1 in main room since the Room temp. control for Zone1 is prioritized.

*4 The wireless remote controller can be used as a thermostat.

5.5 Indoor unit only operation (during installation work)

In the case when DHW or heating operation is required prior to connection of the outdoor unit; i.e. during installation work, an electric heater in indoor unit (*1) can be used.

*1 Model with electric heater only.

1. To start operation

- Check if the indoor unit power supply is OFF, and turn DIP switch 4-4 and 4-5 ON.
- Turn ON the indoor unit power supply.

2. To end operation*2

- Turn OFF the indoor unit power supply.
- Turn DIP switch 4-4 and 4-5 OFF.

*2 When the indoor unit only operation is ended, ensure to check over the settings after outdoor unit is connected.

Note:

Prolonged running of this operation may affect the life of the electric heater.

5.6 Smart grid ready

In DHW or heating operation, the commands in the table below can be used.

IN11	IN12	Meaning
OFF (open)	OFF (open)	Normal operation
ON (short)	OFF (open)	Switch-on recommendation*1
OFF (open)	ON (short)	Switch-off command
ON (short)	ON (short)	Switch-on command*2

Note:

- To activate this function, settings on the main remote controller are required. (Main menu → Service → "Function settings" Ref. add: 0, Unit: 1)
- Heating operation mode (compensation curve or flow temp. control) requires the optional wireless remote controller.

*1 Switch-on recommendation has following 2 modes:

Mode 7 Hot water operation

Additional boost temperature is added onto the usual DHW target temperature.
(1-Inactive (default) /2-Target temp. +3°C/3-Target temp. +5°C)

Mode 8 Heating operation

Heating ON (permitted heating with thermo ON) range is extended.
(1-Inactive (default) /2-Thermo ON temp. +2°C/3-Thermo ON temp. +3°C)

*2 Switch-on command has following 2 modes:

Hot water operation

With electrical heater or DIP SW 1-2 ON → Target temp. : 60°C
Without electrical heater and DIP SW 1-2 OFF → Target temp. : 55°C

Heating operation

Heating is ALWAYS permitted.

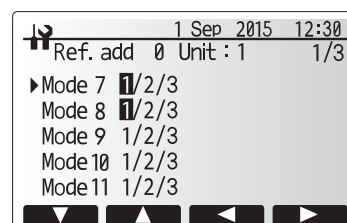
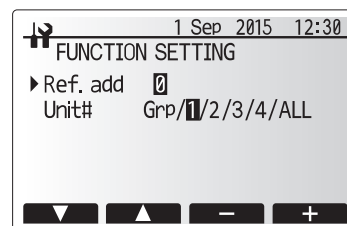
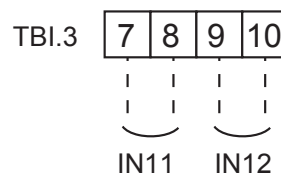

5 System Set Up

5.7 Main remote Controller Options

The cylinder unit comes factory fitted with a main remote controller. This incorporates a thermistor for temperature monitoring and a graphical user interface to enable set-up, view current status and input scheduling functions. The main remote controller is also used for servicing purposes. This facility is accessed via password protected service menus.

To provide the best efficiency Mitsubishi Electric recommends using automatic adaptation function based on room temperature. To use this function a room thermistor needs to be present in a main living area. This can be done in a number of ways the most convenient are detailed below.

Refer to heating section of this manual for instructions on how to set compensation curve, Flow temp. or Room temp. (Auto adaptation).

For instructions on how to set the thermistor input for the FTC please refer to Initial settings section.

The factory setting for space heating mode is set to Room temp. (auto adaptation). If there is no room sensor present in the system, this setting must be changed to either Compensation curve mode or Flow temp. mode.

Note: Auto-adaptation is not available in cooling mode.

■ 1-zone temperature control

Control option A
<p>This option features the main remote controller and the Mitsubishi Electric wireless remote controller. The wireless remote controller is used to monitor room temperature and can be used to make changes to the space heating settings, boost DHW and switch to holiday mode without having to directly use the main remote controller.</p> <p>If more than one wireless remote controller is used, the most recently requested temperature setting will commonly be applied to all rooms by the central control system regardless of which wireless remote controller was used. No hierarchy exists across these remote controllers.</p> <p>Wire the wireless receiver to FTC referring to the wireless remote controller instruction manual. Turn DIP SW1-8 to ON. Before operation configure the wireless remote controller to transmit and receive data referring to the wireless remote controller installation manual.</p>
Control option B
<p>This option features the main remote controller and the Mitsubishi Electric thermistor wired to FTC. The thermistor is used to monitor room temperature but can not make any changes in control operation. Any changes to DHW must be made using the main remote controller mounted on the cylinder unit.</p> <p>Wire the thermistor to the TH1 connector on FTC. The number of room temperature thermistors that can be connected to FTC is always one.</p>

Control option C
<p>This option features the main remote controller being removed from the cylinder unit and situated in a different room. A thermistor built in the main remote controller can be used for monitoring the room temperature for Auto Adaptation function whilst keeping all its features of the main remote controller available.</p> <p>The main remote controller and FTC are connected by a 2-core, 0.3 mm², non-polar cable (local supply) with a maximum length of 500 m.</p> <p>To use the sensor in the main remote controller the main remote controller should come off from the cylinder unit. Otherwise it will detect the temperature of the cylinder unit instead of room temperature. This will affect the output of the space heating.</p> <p>Note: Wiring for main remote controller cable shall be (5 cm or more) apart from power source wiring so that it is not influenced by electrical noise from power source wiring. (Do NOT insert main remote controller cable and power source wiring in the same conduit.)</p>

Control option D (Flow temp. or compensation curve only)
<p>This option features the main remote controller and a locally supplied thermostat wired to FTC. The thermostat is used to set the maximum temperature for heating room. Any changes to DHW must be made using main remote controller mounted on the cylinder unit.</p> <p>The thermostat is wired to IN1 in TBI.1 on FTC. The number of thermostats that can be connected to FTC is always one.</p> <p>★ The wireless remote controller can be also used as a thermostat.</p>

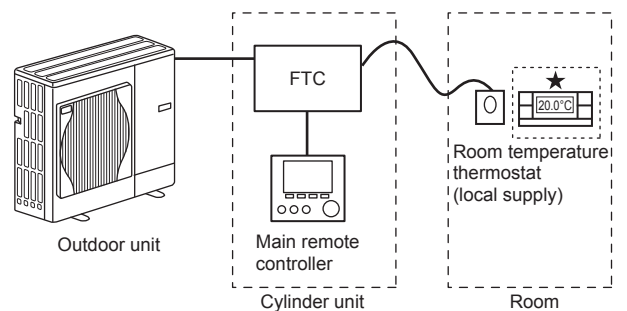
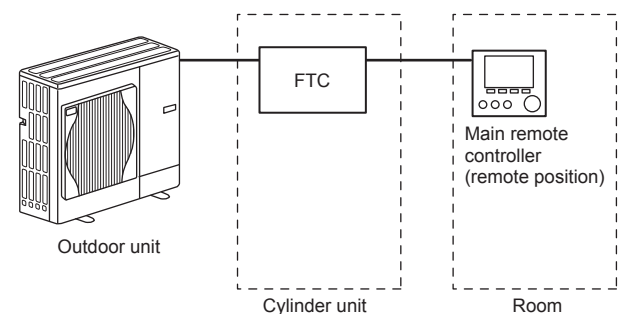
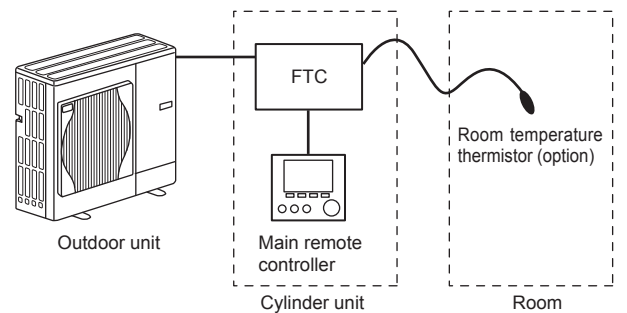
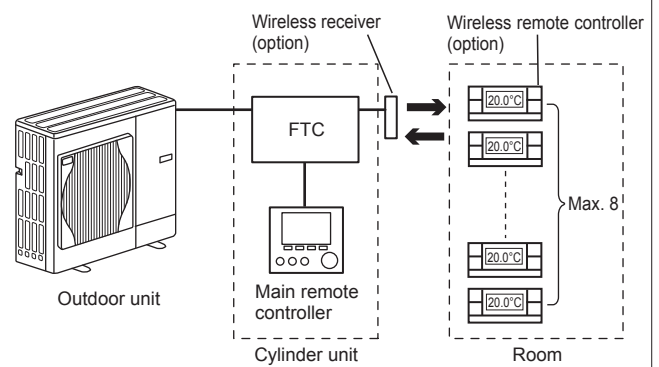
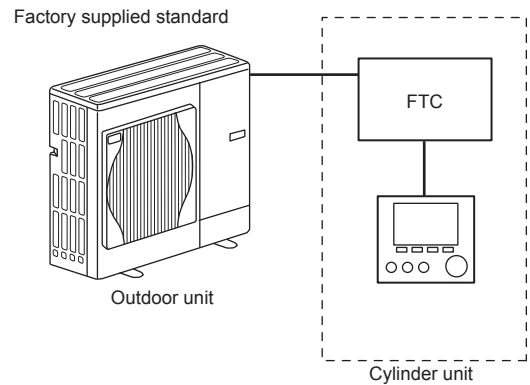

5 System Set Up

2-zone temperature control

Control option A

This option features the main remote controller, the Mitsubishi Electric wireless remote controller and a locally supplied thermostat. The wireless remote controller is used to monitor the Zone1 room temperature and the thermostat is used to monitor the Zone2 room temperature. The thermostat can be also allocated to Zone1 and the wireless remote controller to Zone2.

The wireless remote controller can be also used to make changes to the space heating settings, boost DHW and switch to holiday mode without having to use the main remote controller.

If more than one wireless remote controller is used, the last temperature setting adjustment/demand will be applied to ALL rooms in same zone.

Wire the wireless receiver to FTC referring to the wireless remote controller instruction manual. Turn DIP SW1-8 to ON. Before operation configure the wireless remote controller to transmit and receive data referring to the wireless remote controller installation manual.

The thermostat is used to set the maximum temperature for heating Zone2 room. The thermostat is wired to IN6 on FTC. (If the thermostat is allocated to Zone1, it is wired to IN1 on TBI.1.) (Refer to 5.2.)

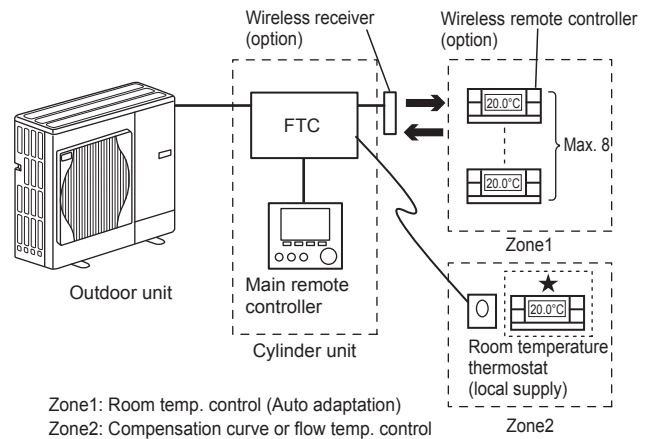

Control option B

This option features the main remote controller, the Mitsubishi Electric thermistor and a locally supplied thermostat that are wired to FTC. The thermistor is used to monitor the Zone1 room temperature and the thermostat is used to control the Zone2 room temperature.

The thermostat can be also allocated to Zone1 and the thermistor to Zone2. The thermistor can not make any changes in control operation. Any changes to DHW must be made using the main remote controller mounted on the cylinder unit. Wire the thermistor to the TH1 connector on FTC.

The number of room temperature thermistors that can be connected to FTC is always one.

The thermostat is used to set the maximum temperature for heating Zone2 room. The thermostat is wired to IN6 on FTC. (If the thermostat is allocated to Zone1, wire it to IN1 on TBI.1.) (Refer to 5.2.)

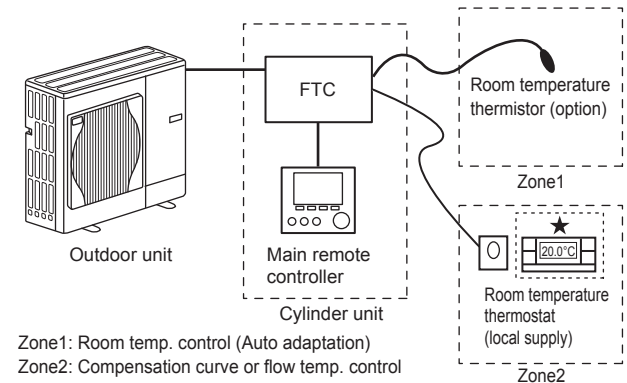

Control option C

This option features the main remote controller (with in-built thermistor) that is removed from the cylinder unit to monitor the Zone1 room temperature and a locally supplied thermostat to monitor the Zone2 room temperature. The thermostat can be also allocated to Zone1 and the thermistor to Zone2.

A thermistor built into the main remote controller can be used for monitoring the room temperature for Auto Adaptation function whilst keeping all its features of the main remote controller available.

The main remote controller and FTC are connected by a 2-core, 0.3 mm², non-polar cable (local supply) with a maximum length of 500 m.

To use the sensor in the main remote controller the main remote controller should be detached from the cylinder unit. Otherwise it will detect the temperature of the cylinder unit instead of room temperature. This will affect the output of the space heating.

The thermostat is used to set the maximum temperature for heating Zone2 room. The thermostat is wired to IN6 on FTC. (If the thermostat is allocated to Zone1, wire it to external input IN1 on TBI.1.) (Refer to 5.2.)

Note: Wiring for main remote controller cable shall be (5 cm or more) apart from power source wiring so that it is not influenced by electrical noise from power source wiring. (Do NOT insert main remote controller cable and power source wiring in the same conduit.)

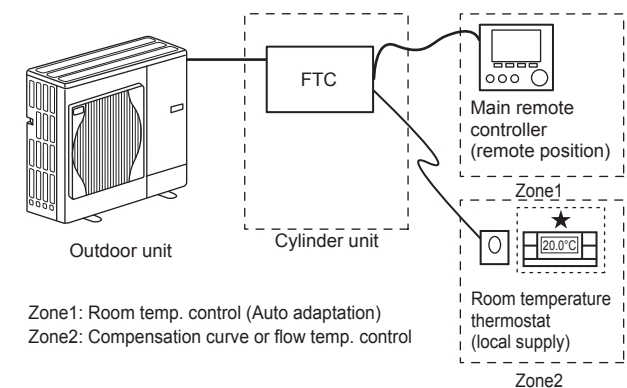

Control option D

This option features the locally supplied thermostats wired to FTC. The thermostats are individually allocated to Zone1 and Zone2. The thermostats are used to set each maximum temperature for heating Zone1 and Zone2 rooms. Any changes to DHW must be made using the main remote controller mounted on the cylinder unit.

The thermostat for Zone1 is wired to IN1 in TBI.1 on FTC.
The thermostat for Zone2 is wired to IN6 in TBI.1 on FTC.

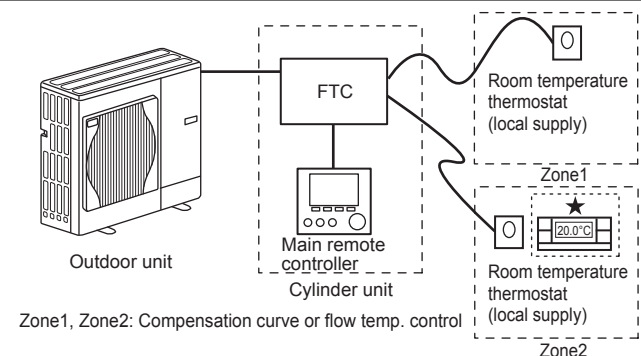

* For the options above, the sensor types can be exchanged between Zone1 and Zone2. (e.g. Wireless remote controller in Zone1 and Room temp. thermostat in Zone2 can be changed to Room temp. thermostat and wireless remote controller, respectively).

★ The wireless remote controller can be also used as a thermostat.

5 System Set Up

5.8 Using SD memory card

The cylinder unit is equipped with an SD memory card interface in FTC. Using an SD memory card can simplify main remote controller settings and can store operating logs. *1

<Handling precautions>

- (1) Use an SD memory card that complies with the SD standards. Check that the SD memory card has a logo on it of those shown to the right.
- (2) SD memory cards to the SD standards include SD, SDHC, miniSD, micro SD, and microSDHC memory cards. The capacities are available up to 32 GB. Choose that with a maximum allowable temperature of 55°C.
- (3) When the SD memory card is a miniSD, miniSDHC, microSD, or micro SDHC memory card, use an SD memory card converter adapter.
- (4) Before writing to the SD memory card, release the write-protect switch.



- (5) Before inserting or ejecting an SD memory card, make sure to power off the system. If an SD memory card is inserted or ejected with the system powered on, the stored data could be corrupted or the SD memory card be damaged. *An SD memory card is live for a short duration after the system is powered off. Before insertion or ejection wait until the LED lamps on the FTC control board are all off.
- (6) The read and write operations have been verified using the following SD memory cards, however, these operations are not always guaranteed as the specifications of these SD memory cards could change.

Manufacturer	Model	Tested in
Verbatim	#44015 0912-61	Mar. 2012
SanDisk	SDSDB-002G-B35	Oct. 2011
Panasonic	RP-SDP04GE1K	Oct. 2011
Arvato	2GB PS8032 TSB 24nm MLC	Jun. 2012
Arvato	2GB PS8035 TSB A19nm MLC	Jul. 2014
Lexar	LSD8GBBBEU300 Rev B	Sep. 2015

Before using a new SD memory card (including the card that comes with the unit), always check that the SD memory card can be safely read and written to by the FTC controller.

<How to check read and write operations>

- a) Check for correct wiring of power supply to the system. For more details, refer to section 4.5.
(Do not power on the system at this point.)
 - b) Insert an SD memory card.
 - c) Power on the system.
 - d) The LED4 lamp lights if the read and write operations are successfully completed. If the LED4 lamp continues blinking or does not light, the SD memory card cannot be read or written to by the FTC controller.
- (7) Make sure to follow the instruction and the requirement of the SD memory card's manufacturer.
 - (8) Format the SD memory card if determined unreadable in step (6). This could make it readable.
Download an SD card formatter from the following site.
SD Association homepage: <https://www.sdcard.org/home/>
 - (9) FTC supports FAT file system but not NTFS file system.
 - (10) Mitsubishi Electric is not liable for any damages, in whole or in part, including failure of writing to an SD memory card, and corruption and loss of the saved data, or the like. Back up saved data as necessary.
 - (11) Do not touch any electronic parts on the FTC control board when inserting or ejecting an SD memory card, or else the control board could fail.

- (a) For insertion, push on the SD memory card until it clicks into place.
 - (b) For ejection, push on the SD memory card until it clicks.
- Note: To avoid cutting fingers, do not touch sharp edges of the SD memory card connector (CN108) on the FTC control board.**

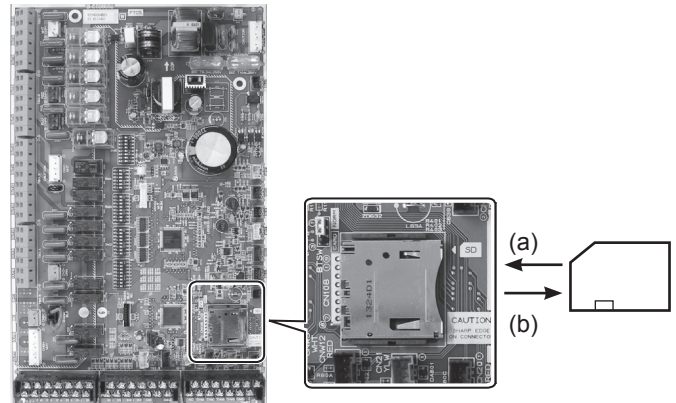

Logos



Capacities

2 GB to 32 GB *2

SD speed classes

All

- * The SD Logo is a trademark of SD-3C, LLC.
- The miniSD logo is a trademark of SD-3C, LLC.
- The microSD logo is a trademark of SD-3C, LLC.

*1 To edit main remote controller settings or to check operating data, an Ecodan service tool (for use with PC) is required.

*2 A 2-GB SD memory card stores up to 30 days of operation logs.

5 System Set Up

5.9 Main remote controller

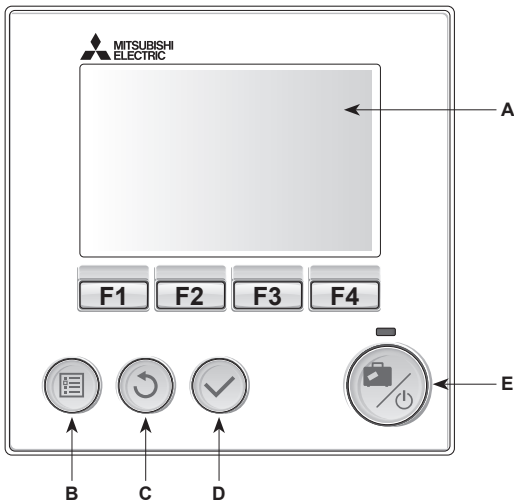

<Main remote controller parts>

Letter	Name	Function
A	Screen	Screen in which all information is displayed
B	Menu	Access to system settings for initial set up and modifications.
C	Back	Return to previous menu.
D	Confirm	Used to select or save. (Enter key)
E	Power/Holiday	If system is switched off pressing once will turn system on. Pressing again when system is switched on will enable Holiday Mode. Holding the button down for 3 seconds will turn the system off. (*1)
F1-4	Function keys	Used to scroll through menu and adjust settings. Function is determined by the menu screen visible on screen A.

*1

When the system is switched off or the power supply is disconnected, the cylinder unit protection functions (e.g. freeze stat. function) will NOT operate. Please beware that without these safety functions enabled the cylinder unit may potentially become exposed to damage.

<Main screen icons>

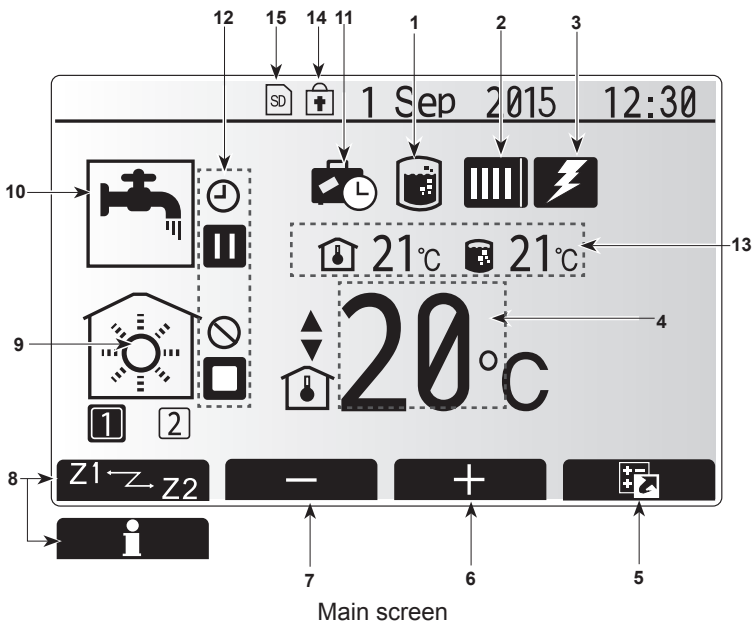

	Icon	Description
1	Legionella prevention	When this icon is displayed 'Legionella prevention mode' is active.
2	Heat pump	<ul style="list-style-type: none"> 'Heat pump' is running. Defrosting Emergency heating
3	Electric heater	When this icon is displayed the 'Electric heaters' (booster or immersion heater) are in use.
4	Target temperature	<ul style="list-style-type: none"> Target flow temperature Target room temperature Compensation curve
5	OPTION	Pressing the function button below this icon will display the option screen.
6	+	Increase desired temperature.
7	-	Decrease desired temperature.
8	Z1 Z2	Pressing the function button below this icon switches between Zone1 and Zone2.
	Information	Pressing the function button below this icon displays the information screen.
9	Space heating/cooling mode	<ul style="list-style-type: none"> Heating mode Zone1 or Zone2 Cooling mode Zone1 or Zone2
10	DHW mode	Normal or ECO mode
11	Holiday mode	When this icon is displayed 'Holiday mode' activated.
12		<ul style="list-style-type: none"> Timer Prohibited Server control Stand-by Stand-by (*2) Stop Operating
13	Current temperature	<ul style="list-style-type: none"> Current room temperature Current water temperature of DHW tank
14		The Menu button is locked or the switching of the operation modes between DHW and Heating operations are disabled in the Option screen.(*3)
15		<ul style="list-style-type: none"> SD memory card is inserted. Normal operation. SD memory card is inserted. Abnormal operation.

*2 This unit is in Stand-by whilst other indoor unit(s) is in operation by priority.

*3 To lock or unlock the Menu, press the BACK and CONFIRM keys simultaneously for 3 seconds.

5 System Set Up

■ Setting the Main remote controller

After the power has been connected to the outdoor and cylinder units (See chapter 4.5) the initial system settings can be entered via the main remote controller.

1. Check all breakers and other safety devices are correctly installed and turn on power to the system.
2. When the main remote controller switched on for the first time, the screen automatically goes to Initial settings menu, Language setting screen and Date/Time setting screen in order.
3. Main remote controller will automatically start up. Wait approximately 6 minutes whilst the control menus load.
4. When the controller is ready a blank screen with a line running across the top will be displayed.
5. Press button E (Power) (refer to page 29) to turn on the system. Before turning on the system, perform initial settings as instructed below.

■ Main Settings Menu

The main settings menu can be accessed by pressing the MENU button. To reduce the risk of untrained end users altering the settings accidentally there are two access levels to the main settings; and the service section menu is password protected.

User Level – Short press

If the MENU button is pressed once for a short time the main settings will be displayed but without the edit function. This will enable the user to view current settings but **NOT** change the parameters.

Installer Level – Long press

If the MENU button is pressed down for 3 seconds the main settings will be displayed with all functionality available.

The color of ◀▶ buttons is inverted as per right figure.

The following items can be viewed and/or edited (dependent on access level).

- Domestic Hot water (DHW)
- Heating/Cooling
- Schedule timer
- Holiday mode
- Initial settings
- Service (Password protected)

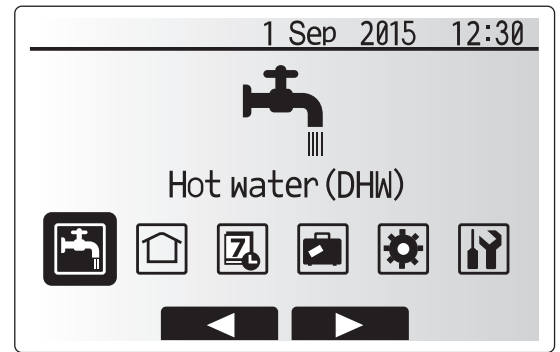

Main menu

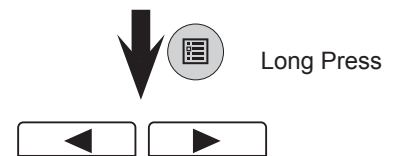

General Operation

- To find the icon that you wish to set, use the F2 and F3 buttons to move between the icons.
- The highlighted icon will appear as a larger version of the center of the screen.
- Press CONFIRM to select and edit the highlighted mode.
- Follow the <Main remote controller Menu Tree> for further setting, using ◀▶ buttons for scrolling or F1 to F4 for selecting.

5 System Set Up

<Main Remote Controller Menu Tree>

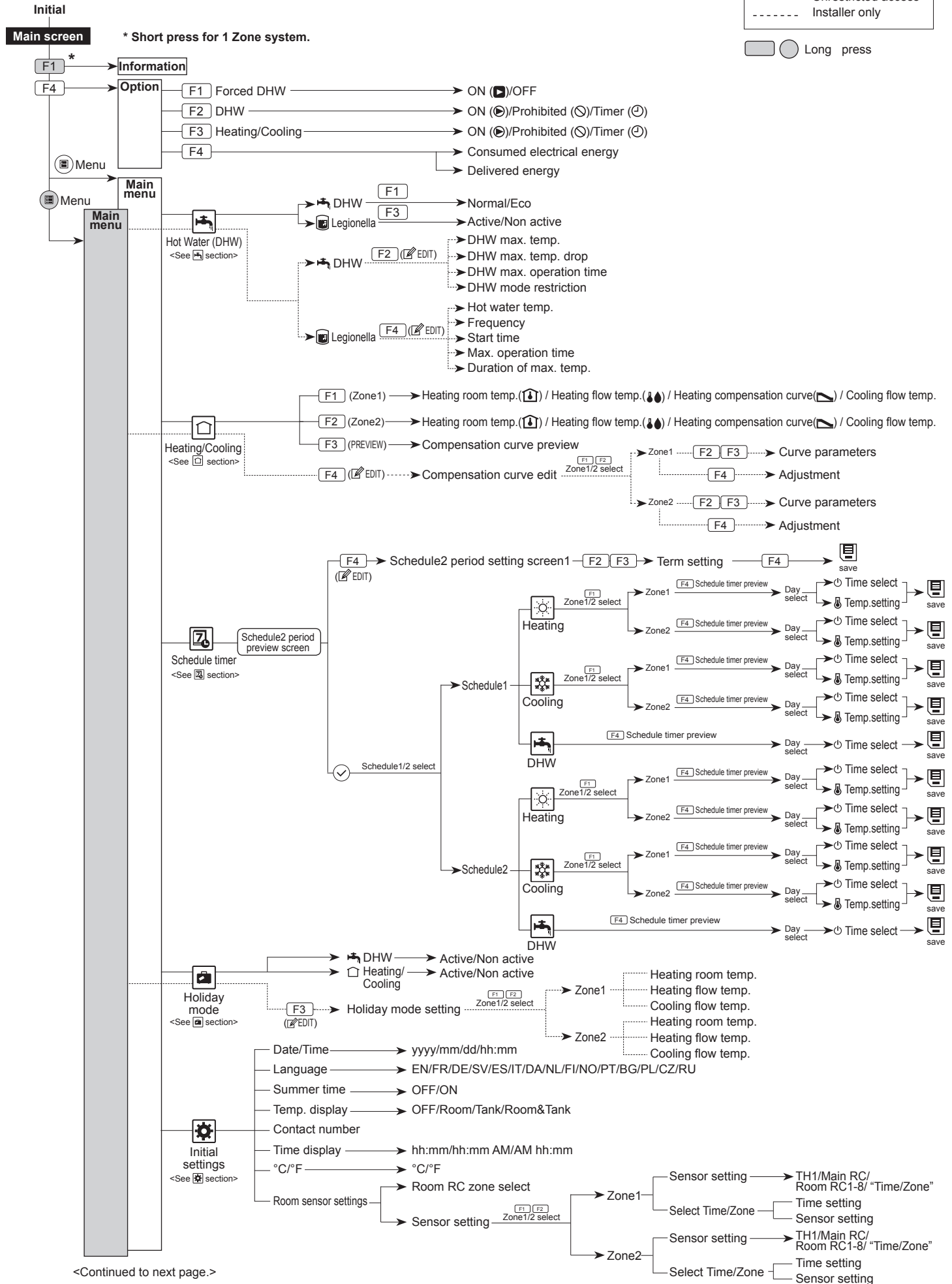
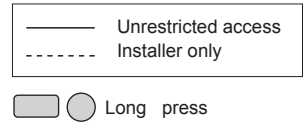

<Continued to next page.>

5 System Set Up

<Continued from the previous page.>

<Main Remote Controller Menu Tree>

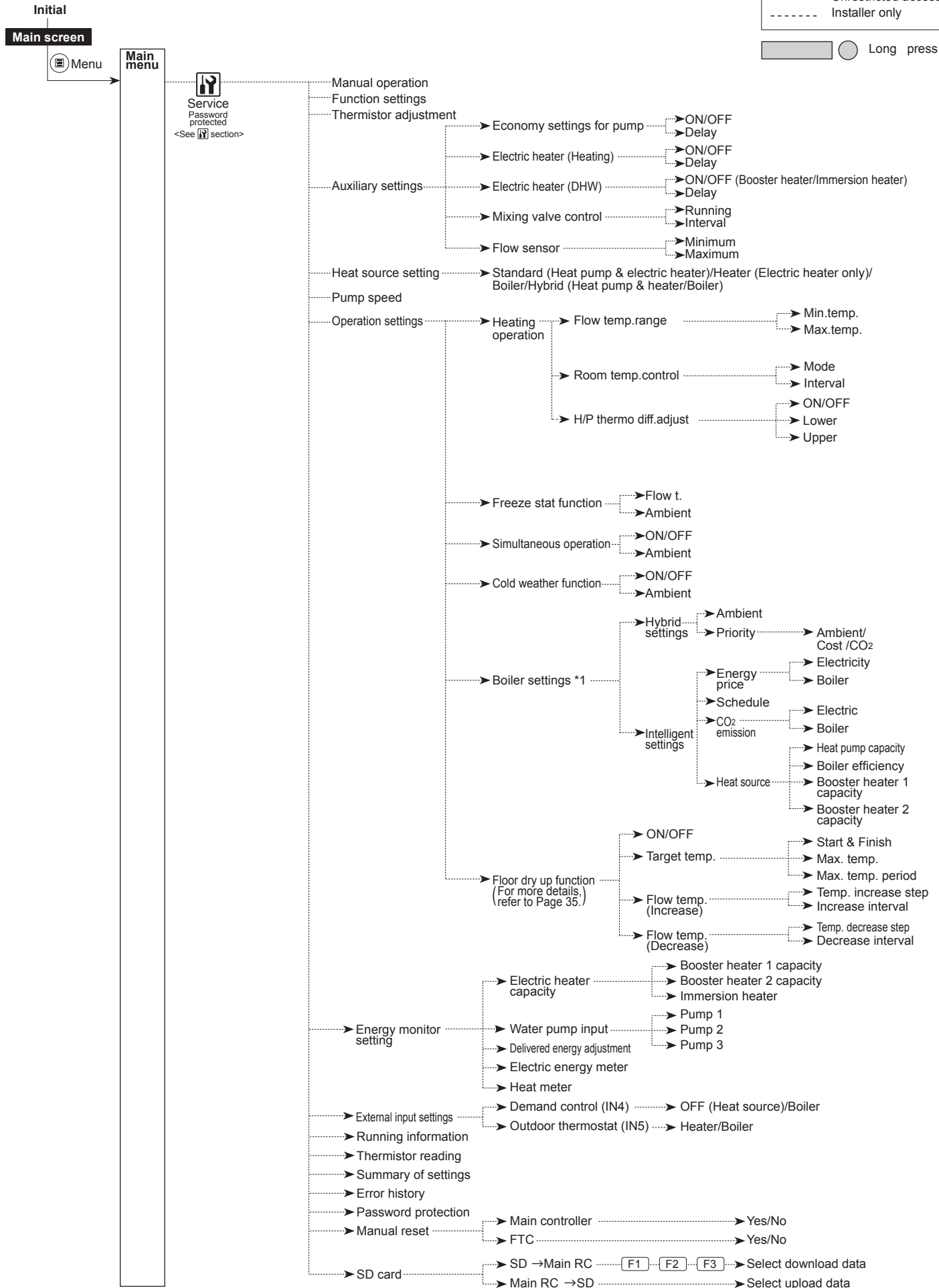

*1 For more details, refer to the installation manual of PAC-TH011HT-E.

EN

5 System Set Up

Domestic Hot Water (DHW)/Legionella Prevention

► For further detail about operation, refer to Operation manual.

Please note that LP mode uses the assistance of electric heaters (if present) to supplement the energy input of the heat pump. Heating water for long periods of time is not efficient and will increase running costs. The installer should give careful consideration to the necessity of legionella prevention treatment whilst not wasting energy by heating the stored water for excessive time periods. The end user should understand the importance of this feature.
ALWAYS COMPLY WITH LOCAL AND NATIONAL GUIDANCE FOR YOUR COUNTRY REGARDING LEGIONELLA PREVENTION.

Heating/Cooling

► For further detail about operation, refer to Operation manual.

Schedule timer

Scheduled timer can be set in two ways, for example; one for summer and the other for winter. (Refer to as "Schedule 1" and "Schedule 2" respectively.) Once the term (months) for the Schedule 1 is specified, rest of the term will be specified as Schedule 2. In each Schedule, an operational pattern of modes (Heating / DHW) can be set. If no operational pattern is set for Schedule2, only the pattern for Schedule 1 will be valid. If Schedule 2 is set to full-year (i.e. March to Feb.), only the operational pattern for Schedule 2 will be valid.

Follow the procedure described in General Operation (Page 30) for the set up operation.

Setting the schedule timer

The preview screen allows you to view the current settings. In 2-zone heating operation, press F1 to switch between Zone1 and Zone2. Days of the week are displayed across the top of the screen. Where day appears underlined the settings are the same for all those days underlined.

Hours of the day and night are represented as a bar across the main part of the screen. Where the bar is solid black, space heating/cooling/DHW (whichever is selected) is allowed.

When scheduling heating, button F1 changes the scheduled variable between time and temperature. This enables a lower temperature to be set for a number of hours e.g. a lower temperature may be required at night when the occupants are sleeping.

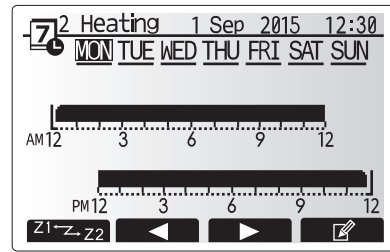

Preview screen

- The schedule timer for space heating/cooling and DHW are set in the same way. However for DHW only time can be used as scheduling variable.
- A small rubbish bin character is also displayed choosing this icon will delete the last unsaved action.
- It is necessary to use the SAVE function F4 button to save settings. CONFIRM does not act as SAVE for this menu.

Holiday mode

► For further detail about operation, refer to Operation manual.

Initial Settings

From the Initial settings menu the installer can set the following.

- Date/Time *Be sure to set it to the local standard time.
- Language
- Summer time
- Temp. display
- Contact number
- Time display
- °C/°F
- Room sensor settings

Follow the procedure described in General Operation for the set up operation.

<Room sensor settings>

For room sensor settings it is important to choose the correct room sensor depending on the heating mode the system will operate in.

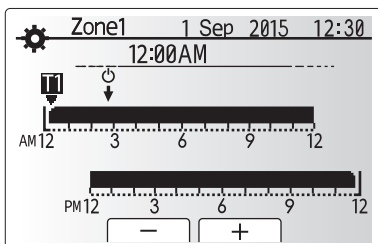

Time/Zone schedule setting screen

Menu subtitle	Description	
Room RC zone select	When 2-zone temperature control is active and wireless remote controllers are available, from Room RC zone select screen, select zone no. to assign to each main remote controller.	
Sensor setting	From sensor setting screen, select a room sensor to be used for monitoring the room temperature from Zone1 and Zone2 separately.	
	Control option (pages 26 - 27)	Corresponding initial settings room sensor
		Zone1 Zone2
	A	Room RC 1-8 (one each for Zone1 and Zone2) *1
	B	TH1 *1
	C	Main remote controller *1
	D	*1 *1
	When different room sensors are used according to the time schedule	Time/ Zone*2 *1
	*1. Not specified (if a locally-supplied room thermostat is used) Room RC 1-8 (one each for Zone1 and Zone2) (if a wireless remote controller is used as a room thermostat)	
	*2. From sensor setting screen, select Time/Zone to make it possible to use different room sensors according to the time schedule set in the Select Time/ Zone menu. The room sensors can be switched up to 4 times within 24 hours.	

5 System Set Up

Service Menu

The service menu provides functions for use by installer or service engineer. It is NOT intended the home owner alters settings within this menu. It is for this reason password protection is required to prevent unauthorised access to the service settings.

The factory default password is "0000".

Follow the procedure described in General Operation for the set up operation.

The service menu is navigated using the F1 and F2 buttons to scroll through the functions. The menu is split across two screens and is comprised of the following functions;

1. Manual operation
2. Function settings
3. Thermistor adjustment
4. Auxiliary settings
5. Heat source setting
6. Pump speed
7. Operation settings
8. Energy monitor settings
9. External input settings
10. Running information
11. Thermistor reading
12. Summary of settings
13. Error history
14. Password protection
15. Manual reset
16. SD card

In this Installation Manual, instructions will be given only for the following functions;

1. Manual operation
2. Auxiliary settings
3. Heat source setting
4. Operation settings
5. Energy monitor settings
6. External input settings
7. Password protection
8. Manual reset
9. SD card

Information on the other functions can be found by consulting the service manual.

Many functions can not be set whilst the indoor unit is running. The installer should turn off the unit before trying to set these functions. If the installer attempts to change the settings whilst the unit is running the main remote controller will display a reminder message prompting the installer to stop operation before continuing. By selecting "Yes" the unit will cease operation.

<Manual operation>

During the filling of the system the water circulation pump and 3-way valve can be manually overridden using manual operation mode.

When manual operation is selected a small timer icon appears in the screen. The function selected will only remain in manual operation for a maximum of 2 hours. This is to prevent accidental permanent override of the FTC.

► Example

Pressing F3 button will switch manual operation mode ON for the main 3-way valve. When filling of the DHW tank is complete the installer should access this menu again and press F3 to deactivate manual operation of the part. Alternatively after 2 hours manual operation mode will no longer be active and FTC will resume control of the part.

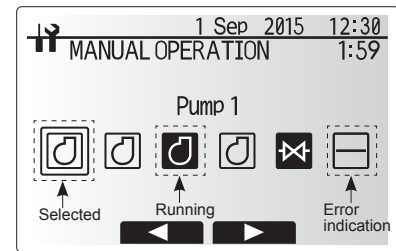

Manual operation menu screen

Manual operation and heat source setting can not be selected if the system is running. A screen will be displayed asking the installer to stop the system before these modes can be activated. The system automatically stops 2 hours after last operation.

<Auxiliary settings>

This function is used to set the parameters for any auxiliary parts used in the system

Menu subtitle	Function/ Description
Economy settings for pump	Water pump stops automatically a specified period of time from when operation is finished.
Delay	Time before pump switches off*1
Electric heater (Heating)	To select "WITH booster heater (ON)" or "WITHOUT booster heater (OFF)" in Heating mode.
Delay	The minimum time required for the booster heater to turn ON after Heating mode has started.
Electric heater (DHW)	To select "WITH (ON)" or "WITHOUT (OFF)" booster heater or immersion heater individually in DHW mode.
Delay	The minimum time required for the booster heater or immersion heater to turn ON from after DHW mode has started. (This setting is applied for both booster and immersion heater.)
Mixing valve	Period from valve fully open (at a hot water mixing ratio of 100%) to valve fully closed (at a cold water mixing ratio of 100%)
control *2	Interval (min) to control the mixing valve.
Flow sensor *3	Minimum The minimum flow rate to be detected at flow sensor.
Maximum	The maximum flow rate to be detected at flow sensor.

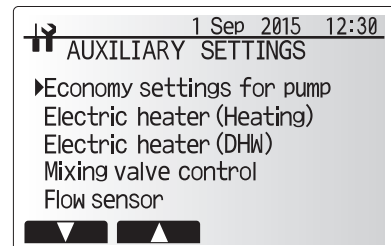

Auxiliary settings menu screen

*1. Decreasing "time before pump switched off" may increase the duration of stand-by in heating/cooling mode.

*2. Set the running time according to the specifications of the actuator of each mixing valve.

It is recommended to set the interval to 2 minutes that is a default value. With the interval set longer, it could take longer to warm up a room.

*3. Do not change the setting since it is set according to the specification of flow sensor attached to the cylinder unit.

<Heat source setting>

The default heat source setting is heat pump and all electric heaters present in the system to be operational. This is referred to as standard operation on the menu.

5 System Set Up

<Operation settings>

Heating operation

This function allows operational setting of flow temperature range from the Ecodan and also the time interval at which the FTC collects and processes data for the auto adaptation mode.

Menu subtitle	Function		Range	Unit	Default
Flow temp. range	Minimum temp.	To minimize the loss by frequent ON and OFF in mild outdoor ambient temperature seasons.	25 - 45	°C	30
	Maximum temp.	To set max. possible flow temperature according to the type of heat emitters.	35 - 60	°C	50
Room temp. control	Mode	Setting for Room temp. control At Fast mode, target outlet water temperature is set higher than the one set at normal mode. This reduces the time to reach the target room temperature when the room temperature is relatively low.*	Normal/ Fast	—	Normal
	Interval	Selectable according to the heat emitter type and the materials of floor (i.e. radiators, floor heating-thick, -thin concrete, wood, etc.)	10 - 60	min	10
Heat pump thermo diff.adjust	On/Off	To minimize the loss by frequent ON and OFF in mild outdoor ambient temperature seasons.	On/Off	—	On
	Lower limit	Prohibits heat pump operation until the flow temperature drops below the target flow temperature plus lower limit value.	-9 - -1	°C	-5
	Upper limit	Allows heat pump operation until the flow temperature rises above the target flow temperature plus upper limit value.	+3 - +5	°C	+5

<Table 5.8.1> Heating operation(Room temp.control table)

Note:

1. The minimum flow temperature that prohibits heat pump operation is 20°C.
2. The maximum flow temperature that allows heat pump operation equals to the maximum temperature set in the Flow temp. range menu.

* Fast mode is not efficient and will increase running cost when compared to normal mode.

Freeze stat function

Menu subtitle	Function/ Description
Freeze stat function *1	An operational function to prevent the water circuit from freezing when outdoor ambient temperature drops.
Flow t.	The target outlet water temperature at water circuit when operating in Freeze stat function. *2
Outdoor ambient temp.	Minimum outdoor ambient temperature which freeze stat function will begin to operate, (3 - 20°C) or choose**. If asterisk (**) is chosen freeze stat function is deactivated. (i.e. primary water freeze risk)"

*1 When the system is turned off, freeze stat function is not enabled.

*2 Flow t. is fixed to 20°C and unchangeable.

Simultaneous Operation

For periods of very low outside temperature this mode can be used. Simultaneous operation allows both DHW and space heating to run together by using the heat pump and/or booster heater to provide space heating whilst only the immersion heater provides heating for DHW. This operation is only available if BOTH a DHW tank AND immersion heater are present on the system.

- Range of outdoor ambient temperature at which simultaneous operation starts is -30°C to 10°C (default -15°C).
- System shall automatically return to routine operation. This will happen when the outdoor ambient temperature rises above the selected temperature for this specific mode of operation.

Cold weather function

For extremely low outdoor ambient temperature conditions when the heat pump's capacity is restricted the heating or DHW is provided only by the electric booster heater (and immersion if present). This function is intended for use during extreme cold periods only. Extensive use of direct electrical heaters ONLY will result in higher power consumption and may reduce working life of heaters and related parts.

- Range of outdoor ambient temperature at which cold weather function starts is -30°C to -10°C (default -15°C).
- System shall automatically return to routine operation. This will happen when the outdoor ambient temperature rises above the selected temp. for this specific mode of operation.

Floor dry up function

The Floor dry up function automatically changes the target hot water temperature in stages to gradually dry concrete when this particular type of underfloor heating system is installed.

Upon completion of the operation the system stops all the operations except the Freeze stat. operation.

For Floor dry up function, the target flow temp. of Zone1 is the same as that of Zone2.

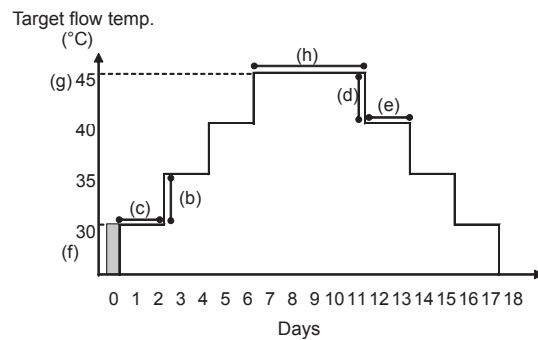

- This function is not available when a PUIH-FRP outdoor unit is connected.
- Disconnect wiring to external inputs of room thermostat, demand control, and outdoor thermostat, or the target flow temperature may not be maintained.

Functions	Symbol	Description	Option/Range	Unit	Default	
Floor dry up function	a	Set the function to ON and power on the system using the main remote controller, and the dry up heating operation will start.	On/Off	—	Off	
Flow temp. (increase)	Flow temp. increase step	b	Sets the increase step of the target flow temperature.	+1 - +10	°C	+5
	Increase interval	c	Sets the period for which the same target flow temperature is maintained.	1 - 7	day	2
Flow temp. (decrease)	Flow temp. decrease step	d	Sets the decrease step of the target flow temperature.	-1 - -10	°C	-5
	Decrease interval	e	Sets the period for which the same target flow temperature is maintained.	1 - 7	day	2
Target temperature	Start & Finish	f	Sets the target flow temperature at the start and the finish of the operation.	25 - 60	°C	30
	Max. target temp.	g	Sets the maximum target flow temperature.	25 - 60	°C	45
	Max. temp. period	h	Sets the period for which the maximum target flow temperature is maintained.	1 - 20	day	5

5 System Set Up

<Energy monitor settings>

In this menu, all parameters required to record the consumed electrical energy and the delivered heat energy which is displayed on the main remote controller can be set. The parameters are an electric heater capacity, supply power of water pump and heat meter pulse.

Follow the procedure described in General Operation for the set up operation.

For Pump 1, *** can be also set besides this setting.

In the case *** is selected, the system acknowledges "factory fitted pump" is selected.

Refer to the section [Energy Monitor] in "3. Technical Information"

<External input settings>

Demand control (IN4)

The selection of "OFF", whilst a signal is being sent to IN4, forcefully stops all the heat source operations and the selection of "Boiler" stops operations of heat pump and electric heater and performs boiler operation.

Outdoor thermostat (IN5)

The selection of "Heater", whilst a signal is being sent to IN5, performs electric-heater-only operation and the selection of "Boiler" performs boiler operation.

<Password protection>

Password protection is available to prevent unauthorised access to the service menu by untrained persons.

Resetting the password

If you forget the password you entered, or have to service a unit somebody else installed, you can reset the password to the factory default of **0000**.

1. From the main settings menu scroll down the functions until Service Menu is highlighted.
2. Press CONFIRM.
3. You will be prompted to enter a password.
4. Hold down buttons F3 and F4 together for 3 seconds
5. You will be asked if you wish to continue and reset the password to default setting.
6. To reset press button F3.
7. The password is now reset to **0000**.

<Manual reset>

Should you wish to restore the factory settings at any time you should use the manual reset function. Please note this will reset ALL functions to the factory default settings.

<SD card>

The use of an SD memory card simplifies the main remote controller settings in the field.

*Ecodan service tool (for use with PC tool) is necessary for the setting.



Password input screen



Password verify screen

6 Commissioning

■ Pre-commissioning exercises- potable/DHW circuit

Initial fill procedure:

Ensure all pipe joints and fittings are tight and secure.

Open the most distant DHW tap/outlet.

Slowly/gradually open the mains water supply to begin filling unit and DHW pipework.

Allow most distant tap to run free and release/purge residual air from installation.

Close tap/outlet to retain fully charged system.

Note: When an immersion heater is fitted, do NOT energise the heater until the DHW tank is full of water. Also do NOT energise any immersion heater if any sterilisation chemicals remain in the DHW tank as this will cause premature failure of the heater.

Initial flush procedure:

Energise system to heat-up cylinder unit contents to a temperature of approx. 30 - 40°C.

Flush/drain the water contents to remove any residue/impurities resulting from the installation works. Use the cylinder unit drain cock to safely discharge the warmed water to drain via a suitable hose.

On completion, close drain cock, re-fill system and resume system commissioning.

7 Service and Maintenance

The indoor cylinder unit is UNVENTED. Under UK law* the system must be serviced **once a year** by a qualified individual. Servicing and maintenance of the outdoor unit should only be done by a Mitsubishi Electric trained technician with relevant qualifications and experience. Any electrical work should be done by a tradesperson with the appropriate electrical qualifications. Any maintenance or

'DIY' fixes done by a non-accredited person could invalidate the Warranty and/or result in damage to the cylinder unit and injury to the person.

* Building regulations – England & Wales Part G3, Scotland P3, Northern Ireland P5. If outside of the UK please refer to local building regulations regarding un-vented hot water storage.

Basic Troubleshooting for Cylinder Unit

The following table is to be used as a guide to possible problems. It is not exhaustive and all problems should be investigated by the installer or another competent person. Users should not attempt to repair the system themselves.

At no time should the system be operating with the safety devices by-passed or plugged.

Fault symptom	Possible cause	Solution
Cold water at taps	Scheduled control off period	Check schedule settings and change if necessary.
	All hot water from DHW tank used	Ensure DHW mode is operating and wait for DHW tank to re-heat.
	Heat pump or electric heaters not working	Contact installer.
Heating system does not get up to set temperature.	Prohibit, schedule or holiday mode selected	Check settings and change as appropriate.
	Incorrectly sized radiators	Contact installer.
	The room in which the temperature sensor is located is at a different temperature to the rest of the house.	Reposition the temperature sensor to a more suitable room.
The cooling system does not cool down to the set temperature. (ONLY for ERST20* models)	Battery problem *wireless control only	Check the battery power and replace if flat.
	When the water in the circulation circuit is unduly hot, Cooling mode starts with a delay for the protection of the outdoor unit.	Normal operation
Heating emitter is hot in the DHW mode. (The room temperature rises.)	When the outdoor ambient temperature is significantly low, Cooling mode does not start running to avoid freezing of the water pipes.	If the freeze stat. function is not necessary, contact installer to change the settings.
	The 3-way valve may have foreign objects in it, or hot water may flow to the heating side due to malfunctions.	Contact installer.
Schedule function inhibits the system from operating but the outdoor unit operates.	Freeze stat. function is active.	Normal operation no action necessary.
Pump runs without reason for short time.	Pump jam prevention mechanism to inhibit the build up of scale.	Normal operation no action necessary.
Mechanical noise heard coming from cylinder unit	Heaters switching on/off	Normal operation no action required.
	3-way valve changing position between DHW and heating mode.	Normal operation no action necessary.
Noisy pipework	Air trapped in the system	Try bleeding radiators (if present) If the symptoms persist contact installer.
	Loose pipework	Contact installer.
Water discharges from one of the relief valves	The system has overheated or overpressurised	Switch off power to the heat pump and any immersion heaters then contact installer.
Small amounts of water drip from one of the relief valves.	Dirt may be preventing a tight seal in the valve	Twist the valve cap in the direction indicated until a click is heard. This will release a small amount of water flushing dirt from the valve. Be very careful the water released will be hot. Should the valve continue to drip contact installer as the rubber seal may be damaged and need replacing.
An error code appears in the main remote controller display.	The indoor or outdoor unit is reporting an abnormal condition	Make a note of the error code number and contact installer.
Heat pump is forced to turn ON and OFF.	Smart grid ready input (IN11 and IN12) is used, and switch-on and off commands are input.	Normal operation no action necessary.

<Power failure>

All setting will be saved for 1 week with no power, after 1 week Date/Time ONLY will be saved.

For more details, refer to the service manual.

<Draining the cylinder unit and its primary heating circuit (local)>

WARNING: DRAINED WATER MAY BE VERY HOT

1. Before attempting to drain the cylinder unit isolate from the electrical supply to prevent the immersion and booster heaters burning out.
2. Isolate cold water feed to DHW tank.
3. Attach a hose to the DHW tank drain cock (No. 23 and 24 on Figure 3.1). The hose should be able to withstand heat as the draining water could be very hot. The hose should drain to a place lower than the DHW tank bottom to encourage siphoning.
Open a hot water tap to start draining without a vacuum.
4. When the DHW tank is drained close drain cock and hot tap.
5. Attach hose to water circuit drain cock (No. 7 on Figure 3.1). The hose should be able to withstand heat as the draining water could be very hot. The hose should drain to a place lower than the booster heater drain cock to encourage siphoning. Open the pump valves and the strainer valves.
6. Water remains in the strainer still after the cylinder unit was drained.
Drain the strainer by removing the strainer cover.

7 Service and Maintenance

■ Error Codes

Code	Error	Action
L3	Circulation water temperature overheat protection	Flow rate may be reduced check for; <ul style="list-style-type: none"> • Water leakage • Strainer blockage • Water circulation pump function (Error code may display during filling of primary circuit, complete filling and reset error code.)
L4	DHW tank water temperature overheat protection	Check the immersion heater and it's contactor.
L5	Indoor unit temperature thermistor (THW1, THW2, THW5, THW6, THW7, THW8, THW9) failure	Check resistance across the thermistor.
L6	Circulation water freeze protection	See Action for L3.
L8	Heating operation error	Re-attach any thermistors that have become dislodged.
L9	Low primary circuit flow rate detected by flow sensor or flow switch (flow switches 1, 2, 3)	See Action for L3. If the flow sensor or flow switch itself does not work, replace it. Caution: The pump valves may be hot, please take care.
LC	Boiler circulation water temperature overheat protection	Check if the setting temperature of the Boiler for heating exceeds the restriction. (See the manual of the thermistors "PAC-TH011HT-E") Flow rate of the heating circuit from the boiler may be reduced. Check for <ul style="list-style-type: none"> • water leakage, • strainer blockage • water circulation pump function.
LD	Boiler temperature thermistor (THWB1, THWB2) failure	Check resistance across the thermistor.
LE	Boiler operation error	See Action for L8. Check the status of the boiler.
LF	Flow sensor failure	Check flow sensor cable for damage or loose connections.
LH	Boiler circulation water freeze protection	Flow rate of the heating circuit from the boiler may be reduced. Check for <ul style="list-style-type: none"> • water leakage • strainer blockage • water circulation pump function.
LJ	DHW operation error (type of external plate HEX)	<ul style="list-style-type: none"> • Check for disconnection of DHW tank water temp. thermistor (THW5). • Flow rate of the sanitary circuit may be reduced. • Check for water circulation pump function.
LL	Setting errors of DIP switches on FTC control board	For boiler operation, check that DIP SW1-1 is set to ON (With Boiler) and DIP SW2-6 is set to ON (With Mixing Tank). For 2-zone temperature control, check DIP SW2-7 is set to ON (2-zone) and DIP SW2-6 is set to ON (With Mixing Tank).
J0	Communication failure between FTC and wireless receiver	Check connection cable for damage or loose connections.
P1	Thermistor (Room temp.) (TH1) failure	Check resistance across the thermistor.
P2	Thermistor (Ref. liquid temp.) (TH2) failure	Check resistance across the thermistor.
P6	Anti-freeze protection of plate heat exchanger	See Action for L3. Check for correct amount of refrigerant.
J1 - J8	Communication failure between wireless receiver and wireless remote controller	Check wireless remote controller's battery is not flat. Check the pairing between wireless receiver to wireless remote controller. Test the wireless communication. (See the manual of wireless system)
E0 - E5	Communication failure between main remote controller and FTC	Check connection cable for damage or loose connections.
E6 - EF	Communication failure between FTC and outdoor unit	Check that the outdoor unit has not been turned off. Check connection cable for damage or loose connections. Refer to outdoor unit service manual.
E9	Outdoor unit receives no signal from indoor unit.	Check both units are switched on. Check connection cable for damage or loose connections. Refer to outdoor unit service manual.
U*, F*	Outdoor unit failure	Refer to outdoor unit service manual.
A*	M-NET communication error	Refer to outdoor unit service manual.

Note: To cancel error codes please switch system off (Press button E, on main remote controller, for 3 seconds).

7 Service and Maintenance

■ Annual Maintenance

It is essential that the cylinder unit is serviced at least once a year by a qualified individual. Any spare parts required should be purchased from Mitsubishi Electric. NEVER bypass safety devices or operate the unit without them being fully operational. For more details, refer to service handbook.

Note: Within the first couple of months of installation, remove and clean the cylinder unit's strainer plus any that are fitted external to the cylinder unit. This is especially important when installing on an existing system.

In addition to annual servicing it is necessary to replace or inspect some parts after a certain period of system operation. Please see tables below for detailed instructions. Replacement and inspection of parts should always be done by a competent person with relevant training and qualifications.

Parts which require regular replacement

Parts	Replace every	Possible failures
Pressure relief valve (PRV) Air vent (Auto/Manual) Drain cock (Primary/Sanitary circuit) Manometer Inlet control group (ICG)*	6 years	Water leakage

* OPTIONAL PARTS for UK

Parts which require regular inspection

Parts	Check every	Possible failures
Immersion heater	2 years	Earth leakage causing circuit breaker to activate (Heater is always OFF)
Water circulation pump (Primary circuit)	20,000 hrs (3 years)	Water circulation pump failure

Parts which must NOT be reused when servicing

- * O-ring
- * Gasket

Note: Always replace the gasket for pump with a new one at each regular maintenance (every 20,000 hours of use or every 3 years).

7 Service and Maintenance

■ Engineers Forms

Should settings be changed from default, please enter and record new setting in 'Field Setting' column. This will ease resetting in the future should the system use change or the circuit board need to be replaced.

Commissioning/Field settings record sheet

Main remote controller screen		Parameters	Default setting	Field setting	Notes	
Main	Zone1 heating room temp.		10°C - 30°C	20°C		
	Zone2 heating room temp. *12		10°C - 30°C	20°C		
	Zone1 heating flow temp.		25°C - 60°C	45°C		
	Zone2 heating flow temp. *1		25°C - 60°C	35°C		
	Zone1 cooling flow temp. *13		5°C - 25°C	15°C		
	Zone2 cooling flow temp. *13		5°C - 25°C	20°C		
	Zone1 heating compensation curve		-9°C - + 9°C	0°C		
	Zone2 heating compensation curve *1		-9°C - + 9°C	0°C		
	Holiday mode		Active/Non active/Set time	—		
	Forced DHW operation		On/Off	—		
Option	DHW		On/Off/Timer	On		
	Heating/Cooling *13		On/Off/Timer	On		
	Energy monitor		Consumed electrical energy/Delivered energy	—		
Setting	DHW	Operation mode	Normal/Eco *15	Normal		
		DHW max. temp.	40°C - 60°C *2	50°C		
DHW temp. drop		5°C - 30°C	10°C			
DHW max. operation time		30 - 120 min	60 min			
DHW mode restriction		30 - 120 min	30 min			
Legionella prevention		Active	Yes/No	Yes		
	Hot water temp.	60°C - 70°C *2	65°C			
	Frequency	1 - 30 days	15 days			
	Start time	00.00 - 23.00	03.00			
	Max. operation time	1 - 5 hours	3 hours			
	Duration of maximum temp.	1 - 120 min	30 min			
Heating/Cooling *13	Zone1 operation mode		Heating room temp./ Heating flow temp./ Heating compensation curve/ Cooling flow temp.	Room temp.		
	Zone2 operation mode *1		Heating room temp./ Heating flow temp./ Heating compensation curve/ Cooling flow temp.	Compensation curve		
Compensation curve	Hi flow temp. set point	Zone1 outdoor ambient temp.	-30°C - +33°C *3	-15°C		
		Zone1 flow temp.	25°C - 60°C	50°C		
		Zone2 outdoor ambient temp. *1	-30°C - +33°C *3	-15°C		
		Zone2 flow temp. *1	25°C - 60°C	40°C		
	Lo flow temp. set point	Zone1 outdoor ambient temp.	-28°C - +35°C *4	35°C		
		Zone1 flow temp.	25°C - 60°C	25°C		
		Zone2 outdoor ambient temp. *1	-28°C - +35°C *4	35°C		
		Zone2 flow temp.	25°C - 60°C	25°C		
	Adjust	Zone1 outdoor ambient temp.	-29°C - +34°C *5	—		
		Zone1 flow temp.	25°C - 60°C	—		
		Zone2 outdoor ambient temp. *1	-29°C - +34°C *5	—		
		Zone2 flow temp. *1	25°C - 60°C	—		
Holiday	DHW		Active/Non active	Non active		
	Heating/Cooling *13		Active/Non active	Active		
	Zone1 heating room temp.		10°C - 30°C	15°C		
	Zone2 heating room temp. *12		10°C - 30°C	15°C		
	Zone1 heating flow temp.		25°C - 60°C	35°C		
	Zone2 heating flow temp. *1		25°C - 60°C	25°C		
	Zone1 cooling flow temp. *13		5°C - 25°C	25°C		
	Zone2 cooling flow temp. *13		5°C - 25°C	25°C		
Initial settings	Language		EN/FR/DE/SV/ES/IT/DA/NL/FI/NO/PT/BG/PL/CZ/RU	EN		
	°C/°F		°C/°F	°C		
	Summer time		On/Off	Off		
	Temp. display		Room/DHW tank/Room&DHW tank /Off	Off		
	Time display		hh:mm/hh:mm AM/AM hh:mm	hh:mm		
	Room sensor settings for Zone1		TH1/Main RC/Room RC1-8/"Time/Zone"	TH1		
	Room sensor settings for Zone2 *1		TH1/Main RC/Room RC1-8/"Time/Zone"	TH1		
	Room RC zone select *1		Zone1/Zone2	Zone1		
Service menu	Thermistor adjustment	THW1	-10°C - +10°C	0°C		
		THW2	-10°C - +10°C	0°C		
		THW5	-10°C - +10°C	0°C		
		THW6	-10°C - +10°C	0°C		
		THW7	-10°C - +10°C	0°C		
		THW8	-10°C - +10°C	0°C		
		THW9	-10°C - +10°C	0°C		
		THWB1	-10°C - +10°C	0°C		
		THWB2	-10°C - +10°C	0°C		
		Auxiliary settings	Economy settings for pump.		On/Off *6	On
	Delay (3 - 60 min)			10 min		
	Electric heater (Heating)		Space heating: On (used)/Off (not used)		On	
			Electric heater delay timer (5 - 180 min)			30 min
	Electric heater (DHW)		Booster heater DHW: On (used)/Off (not used)		On	
			Immersion heater DHW: On (used)/Off (not used)		On	
	Electric heater delay timer (15 - 30 min)			15 min		
	Mixing valve control		Running (10 - 240 sec)	120 sec		
	Interval (1 - 30 min)			2 min		
	Flow sensor		Minimum(0 - 100L/min)			5 L/min
		Maximum(0 - 100L/min)			100 L/min	

*1 The settings related to Zone2 can be switched only when 2 zone temperature control is enabled (when DIP SW2-6 and SW 2-7 are ON).

*2 For the model without both booster and immersion heater, it may not reach the set temperature depending on the outside ambient temperature.

*3 The lower limit is -15°C depending on the connected outdoor unit.

*4 The lower limit is -13°C depending on the connected outdoor unit.

*5 The lower limit is -14°C depending on the connected outdoor unit.

(Continued to next page.)

EN

7 Service and Maintenance

Engineers Forms

Commissioning/Field settings record sheet (continued from the previous page)

Main remote controller screen				Parameters	Default setting	Field setting	Notes	
Service menu	Pump speed			Pump speed(1 - 5)	5			
	Heat source setting			Standard/Heater/Boiler/Hybrid *7	Standard			
	Operation settings	Heating operation *8	Flow temp.range *10	Min.temp.(25 - 45°C)	30°C			
				Max.temp.(35 - 60°C)	50°C			
			Room temp.control *14	Mode(Normal/Fast)	Normal			
				Interval(10 - 60min)	10min			
			Heat pump thermo diff.adjust	On/Off *6	On			
				Lower limit(-9 - -1°C)	-5°C			
				Upper limit(+3 - +5°C)	5°C			
		Freeze stat function *11			Outdoor ambient temp. (3 - 20°C) / **	5°C		
		Simultaneous operation (DHW/Heating)			On/Off *6	Off		
				Outdoor ambient temp. (-30 - +10°C) *4	-15°C			
	Cold weather function			On/Off *6	Off			
			Outdoor ambient temp. (-30 - -10°C) *4	-15°C				
	Boiler operation			Hybrid settings	Outdoor ambient temp. (-30 - +10°C) *4	-15°C		
				Priority mode (Ambient/ Cost/CO2) *16	Ambient			
			Intelligent settings	Energy price *9	Electricity (0.001 - 999 */kWh)	0.5 */kWh		
					Boiler (0.001 - 999 */kWh)	0.5 */kWh		
			CO2 emission		Electricity (0.001 - 999 kg -CO2/kWh)	0.5 kg -CO2/kWh		
					Boiler (0.001 - 999 kg -CO2/kWh)	0.5 kg -CO2/kWh		
			Heat source		Heat pump capacity (1 - 40 kW)	11.2 kW		
					Boiler efficiency (25 - 150%)	80%		
					Booster heater 1 capacity (0 - 30 kW)	2 kW		
					Booster heater 2 capacity (0 - 30 kW)	4 kW		
	Floor dry up function			On/Off *6	Off			
			Target temp.		Start&Finish (25 - 60°C)	30°C		
					Max. temp. (25 - 60°C)	45°C		
					Max. temp. period (1 - 20 days)	5 days		
			Flow temp. (Increase)		Temp. increase step (+1 - +10°C)	+5°C		
					Increase interval (1 - 7 days)	2 days		
			Flow temp. (Decrease)		Temp. decrease step (-1 - -10°C)	-5°C		
					Decrease interval (1 - 7 days)	2 days		
Energy monitor settings			Electric heater capacity	Booster heater 1 capacity	0 - 30kW	2kW		
				Booster heater 2 capacity	0 - 30kW	4kW		
				Immersion heater capacity	0 - 30kW	0kW		
Delivered energy adjustment					-50 - +50%	0%		
Water pump input			Pump 1	0 - 200W or ***(factory fitted pump)	***			
			Pump 2	0 - 200W	0W			
			Pump 3	0 - 200W	0W			
Electric energy meter					0.1/1/10/100/1000 pulse/kWh	1 pulse/kWh		
Heat meter					0.1/1/10/100/1000 pulse/kWh	1 pulse/kWh		
External input settings			Demand control (IN4)	Heat source OFF/Boiler operation		Boiler operation		
			Outdoor thermostat (IN5)	Heater operation/Boiler operation		Boiler operation		

*6 On: the function is active; Off: the function is inactive.

*7 When DIP SW1-1 is set to OFF "WITHOUT Boiler" or SW2-6 is set to OFF "WITHOUT Mixing tank", neither Boiler nor Hybrid can be selected.

*8 Valid only when operating in Room temp. control mode.

9 "" of "*/kWh" represents currency unit (e.g. € or £ or the like)

*10 Valid only when operating in Heating room temperature.

*11 If asterisk (**) is chosen freeze stat function is deactivated. (i.e. primary water freeze risk)

*12 The settings related to Zone2 can be switched only when 2-zone temperature control or 2-Zone valve ON/OFF control is active.

13 Cooling mode settings are available for ERST20 model only.

*14 When DIP SW5-2 is set to OFF, the function is active.

*15 When the cylinder unit is connected with a PUMY-P outdoor unit, the mode is fixed to "Normal".

*16 When the cylinder unit is connected with a PUMY-P outdoor unit, the mode is fixed to "Ambient".

8 Supplementary information

■ Refrigerant collecting (pumpdown) for split model systems only

Refer to "Refrigerant collection" in the outdoor unit installation manual or service manual.

■ Back-up operation of boiler

Heating operation is backed up by boiler.

For more details, refer to the installation manual of PAC-TH011HT-E.

<Installation & System set up>

1. Set DIP-SW 1-1 to ON "With boiler" and SW2-6 to ON "With Mixing tank".
2. Install the thermistors THWB1 (Flow temp.) and THWB2 (Return temp.) *1 on the boiler circuit.
3. Connect the output wire (OUT10: Boiler operation) to the input (room thermostat input) on the boiler. *2
4. Install one of the following room temperature thermostats. *3

- Wireless remote controller (option)
- Room temp. thermostat (local supply)
- Main remote controller (remote position)

*1 The boiler temperature thermistor is an optional part.

*2 OUT10 has no voltage across it.

*3 Boiler heating is controlled on/off by the Room temp. thermostat.

<Main remote controller settings>

1. Go to Service menu > Heat source setting and choose "Boiler" or "Hybrid". *4
2. Go to Service menu > Operation settings > Boiler settings to make detailed settings for "Hybrid" above .

*4 The "Hybrid" automatically switches heat sources between Heat pump (and Electric heater) and boiler.

■ Product fiche of temperature control

- (a) Supplier's name: MITSUBISHI ELECTRIC CORPORATION
- (b) Supplier's model identifier: PAR-WT50R-E and PAR-WR51R-E
- (c) The class of the temperature control: VI
- (d) The contribution of the temperature control to seasonal space heating energy efficiency: 4%

Please be sure to put the contact address/telephone number on this manual before handing it to the customer.



mitsubishi electric corporation

HEAD OFFICE: TOKYO BUILDING, 2-7-3, MARUNOUCHI, CHIYODA-KU, TOKYO 100-8310, JAPAN