

PARTS CATALOG

R410A
[Model Name]

EHST20C-VM2C
 EHST20C-VM6C
 EHST20C-YM9C
 EHST20C-TM9C
 EHST20C-VM2EC
 EHST20C-VM6EC
 EHST20C-YM9EC
 EHST20C-MHCW
 EHST20C-MEC
 EHST20D-VM2C
 EHST20D-VM2EC
 EHST20D-YM9C
 EHST20D-MHCW
 EHST20D-MEC
 EHST20D-MHC

[Service Ref.]

Refer to page 2.

EHPT20X-VM2C
 EHPT20X-VM6C
 EHPT20X-YM9C
 EHPT20X-TM9C
 EHPT20X-MHCW
 ERST20C-VM2C
 ERST20C-MEC
 ERST20D-VM2C
 ERST20D-MEC

Revision:

- Added EHST20C-VM2CR2.UK, EHST20C-VM6CR2.UK, EHST20C-YM9CR2.UK, EHST20C-TM9CR2.UK, EHST20C-VM2ECR2.UK, EHST20C-VM6ECR2.UK, EHST20C-YM9ECR2.UK, EHST20C-MHCWR2.UK, EHST20C-MECR2.UK, EHST20D-VM2CR2.UK, EHST20D-VM2ECR2.UK, EHST20D-YM9CR2.UK, EHST20D-MHCWR2.UK, EHST20D-MECR2.UK, EHST20D-MHCR2.UK, EHPT20X-VM2CR2.UK, EHPT20X-VM6CR2.UK, EHPT20X-YM9CR2.UK, EHPT20X-TM9CR2.UK, EHPT20X-MHCWR2.UK, ERST20C-VM2CR2.UK, ERST20C-MECR2.UK, ERST20D-VM2CR2.UK and ERST20D-MECR2.UK in REVISED EDITION-D.
- Some descriptions have been modified.

OCB570 REVISED EDITION-C is void.

Note:

- RoHS compliant products have <G> mark on the spec name plate.

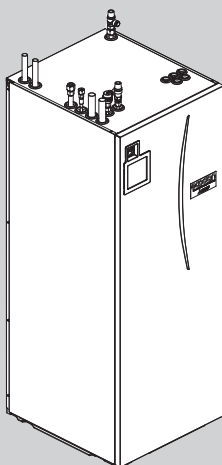

CYLINDER UNIT

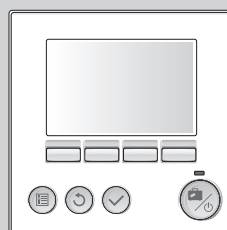
 MAIN REMOTE
CONTROLLER

CONTENTS

1. RoHS PARTS LIST..... 4
2. OPTIONAL PARTS..... 52

SERVICE MANUAL (OCH570)

[Service Ref.]

**EHST20C-VM2C.UK
EHST20C-VM6C.UK
EHST20C-YM9C.UK
EHST20C-TM9C.UK
EHST20C-VM2EC.UK
EHST20C-VM6EC.UK
EHST20C-YM9EC.UK
EHST20C-MHCW.UK
EHST20C-MEC.UK
EHST20D-VM2C.UK
EHST20D-VM2EC.UK
EHST20D-YM9C.UK
EHST20D-MHCW.UK
EHST20D-MEC.UK
EHST20D-MHC.UK
EHPT20X-VM2C.UK
EHPT20X-VM6C.UK
EHPT20X-YM9C.UK
EHPT20X-TM9C.UK
EHPT20X-MHCW.UK
ERST20C-VM2C.UK
ERST20C-MEC.UK
ERST20D-VM2C.UK
ERST20D-MEC.UK**

**EHST20C-VM2CR1.UK
EHST20C-VM6CR1.UK
EHST20C-YM9CR1.UK
EHST20C-TM9CR1.UK
EHST20C-VM2ECR1.UK
EHST20C-VM6ECR1.UK
EHST20C-YM9ECR1.UK
EHST20C-MHCWR1.UK
EHST20C-MECR1.UK
EHST20D-VM2CR1.UK
EHST20D-VM2ECR1.UK
EHST20D-YM9CR1.UK
EHST20D-MHCWR1.UK
EHST20D-MECR1.UK
EHST20D-MHCR1.UK
EHPT20X-VM2CR1.UK
EHPT20X-VM6CR1.UK
EHPT20X-YM9CR1.UK
EHPT20X-TM9CR1.UK
EHPT20X-MHCWR1.UK
ERST20C-VM2CR1.UK
ERST20C-MECR1.UK
ERST20D-VM2CR1.UK
ERST20D-MECR1.UK**

**EHST20C-VM2CR2.UK
EHST20C-VM6CR2.UK
EHST20C-YM9CR2.UK
EHST20C-TM9CR2.UK
EHST20C-VM2ECR2.UK
EHST20C-VM6ECR2.UK
EHST20C-YM9ECR2.UK
EHST20C-MHCWR2.UK
EHST20C-MECR2.UK
EHST20D-VM2CR2.UK
EHST20D-VM2ECR2.UK
EHST20D-YM9CR2.UK
EHST20D-MHCWR2.UK
EHST20D-MECR2.UK
EHST20D-MHCR2.UK
EHPT20X-VM2CR2.UK
EHPT20X-VM6CR2.UK
EHPT20X-YM9CR2.UK
EHPT20X-TM9CR2.UK
EHPT20X-MHCWR2.UK
ERST20C-VM2CR2.UK
ERST20C-MECR2.UK
ERST20D-VM2CR2.UK
ERST20D-MECR2.UK**

This page is intentionally left blank.

EHST20C-VM2C.UK
 EHST20C-VM2CR1.UK
 EHST20C-TM9C.UK
 EHST20C-TM9CR1.UK

EHST20C-VM6C.UK
 EHST20C-VM6CR1.UK
 ERST20C-VM2C.UK
 ERST20C-VM2CR1.UK

EHST20C-YM9C.UK
 EHST20C-YM9CR1.UK

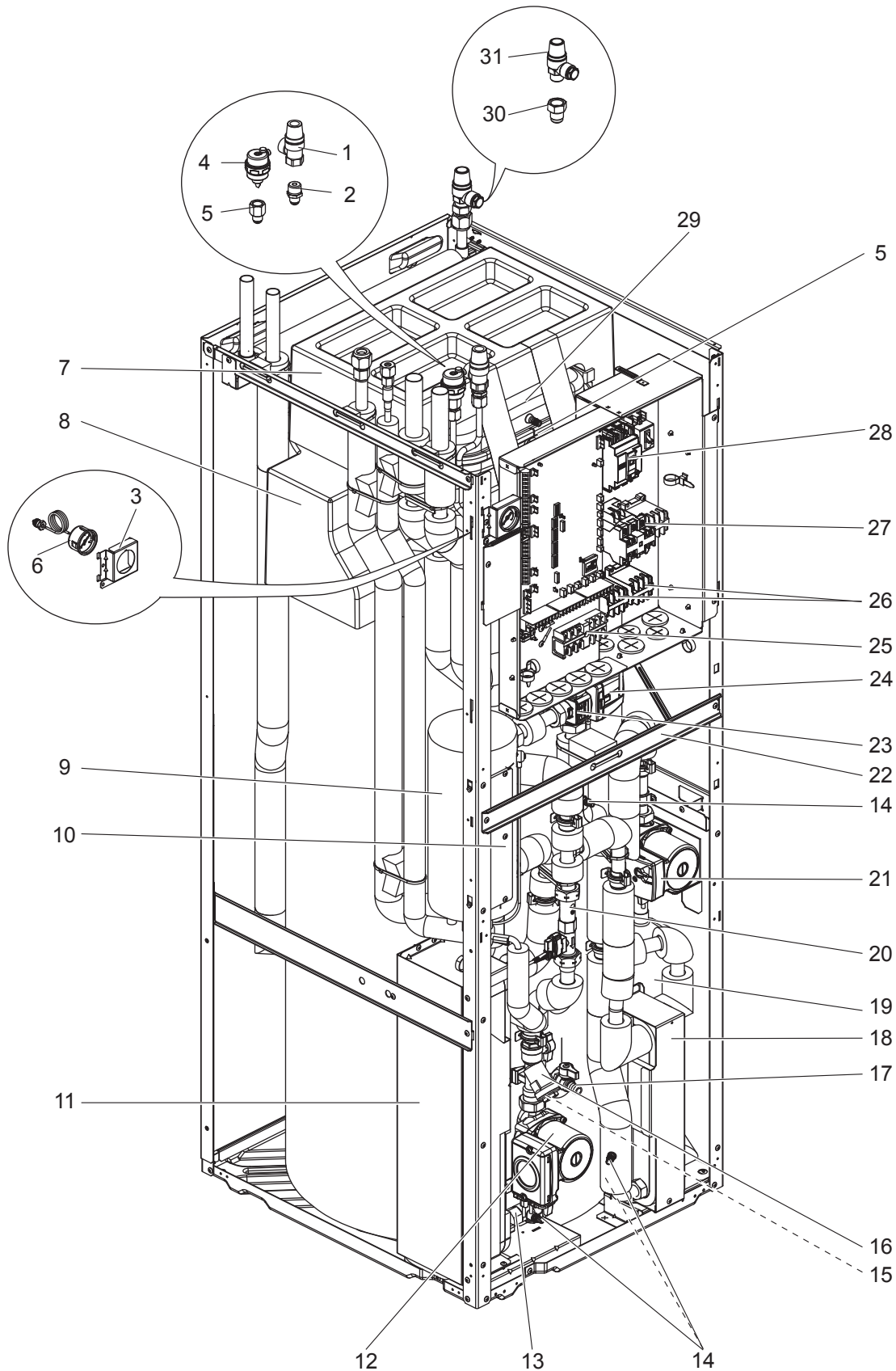

RoHS PARTS LIST

No.	RoHS	Parts No.	Parts name	Specification	Q'ty/unit					Remarks	Wiring diagram symbol	Required regular replacement (*: Required regular inspection)
					EHST20C-VM2C(R1).UK	EHST20C-VM6C(R1).UK	EHST20C-VM9C(R1).UK	EHST20C-TM9C(R1).UK	ERST20C-VM2C(R1).UK			
1	G	S70 C21 404	PRESSURE RELIEF VALVE	3bar	1	1	1	1	1			6 years
2	G	S70 C60 096	FLARE JOINT	3/8F-R1/2	1	1	1	1	1			
3	G	S70 C50 206	MANOMETER STAY		1	1	1	1	1			
4	G	S70 C17 150	AIR VENT (AUTOMATIC)		1	1	1	1	1			6 years
5	G	S70 C50 096	FLARE JOINT	3/8F-G3/8	2	2	2	2	2			
6	G	S70 C20 205	MANOMETER		1	1	1	1	1			6 years
7	G	—	EXPANSION VESSEL CUSHION ASSY		1	1	1	1	1	BK00T056G02		
8	G	—	TANK CUSHION TOP ASSY		1	1	1	1	1	BK00T055G03		
9	G	S70 C11 441	BOOSTER HEATER	1 ϕ 230V 2 kW	1				1		BH1	
	G	S70 C12 441	BOOSTER HEATER	1 ϕ 230V 6 kW		1					BH1, BH2	
	G	S70 C13 441	BOOSTER HEATER	3 ϕ 400V 9 kW			1				BH1, BH2	
	G	S70 C14 441	BOOSTER HEATER	3 ϕ 230V 9 kW				1			BH1, BH2	
10	G	—	HEATER STAY		1	1	1	1	1	BK00R873G02		
11	G	S70 C70 408	WATER COIL ASSY (5HP)	MWA2	1	1	1	1	1	REFRIGERANT-WATER		
12	G	S70 C06 355	WATER PUMP		1	1	1	1		FOR PRIMARY CIRCUIT	MP1	20,000hrs (3 years)(*)
	G	S70 C09 355	WATER PUMP						1			
13	G	S70 C20 356	PUMP VALVE		1	1	1	1	1			
14	G	S70 C10 358	DRAIN COCK/AIR VENT (WATER CAP ASSY 320)		4	4	4	4	4	FOR PRIMARY/SANITARY CIRCUIT		6 years
15	G	S70 C28 460	STRAINER PACKING		1	1	1	1	1	FOR STRAINER		
16	G	S70 C20 452	STRAINER VALVE		1	1	1	1	1			
17	G	S70 C15 357	DRAIN COCK		1	1	1	1	1	FOR TANK		
18	G	S70 C80 408	WATER COIL ASSY (W)	CB18-24H	1	1	1	1	1	WATER-WATER		
19	G	S70 C50 357	SCALE TRAP		1	1	1	1	1			
20	G	S70 C44 266	FLOW SENSOR (BODY & CABLE)		1	1	1	1	1			
21	G	S70 C05 355	WATER PUMP		1	1	1	1	1	FOR SANITARY CIRCUIT	MP4	
22	G	—	DIV FRAME H DWG		1	1	1	1	1	BK00T057G01		
23	G	S70 C24 406	3WAY VALVE (DIVERTING VALVE)		1	1	1	1	1			
24	G	S70 C25 762	3WAY VALVE (DIVERTING MOTOR)		1	1	1	1	1		3WV	
25	G	S70 C20 515	TERMINAL BED	6P	1	1	1	1	1	(#250LNE+S123)		
26	G	S70 C39 708	CONTACTOR	30A	1	2	2	2	1		BHC1, BHC2	
27	G	S70 C39 708	CONTACTOR	30A	1		1		1		BHCP	
	G	S70 C29 708	CONTACTOR	45A		1		1			BHCP	
28	G	S70 C20 239	EARTH LEAKAGE BREAKER	1 ϕ 20A	1				1		ECB1	
	G	S70 C60 239	EARTH LEAKAGE BREAKER	1 ϕ 40A		1					ECB1	
	G	S70 C70 239	EARTH LEAKAGE BREAKER	3 ϕ 30A			1	1			ECB1	
29	G	S70 C15 402	EXPANSION VESSEL	12L	1	1	1	1	1			
30	G	S70 C70 096	FLARE JOINT	5/8F-R1/2	1	1	1	1	1			
31	G	S70 C30 404	PRESSURE RELIEF VALVE	10bar	1	1	1	1	1	FOR SANITARY SIDE		
(32)	G	S70 C23 460	O-RING	BLACK	12	12	12	12	12			
(33)	G	S70 C10 465	FASTENER		10	10	10	10	10	FOR QUICK CONNECTION		
(34)	G	S70 C01 800	GREASE	100 g	10*	10*	10*	10*	10*	FOR QUICK CONNECTION		

Parts number that is circled is not shown in the figure.

Do not reuse the O-ring or strainer packing that was once removed, but be sure to replace with a new one.

* Apply grease appropriately on the O-ring for the quick connection in the unit.

RoHS PARTS LIST

EHST20C-VM2CR2.UK
EHST20C-TM9CR2.UK

EHST20C-VM6CR2.UK
ERST20C-VM2CR2.UK

EHST20C-YM9CR2.UK

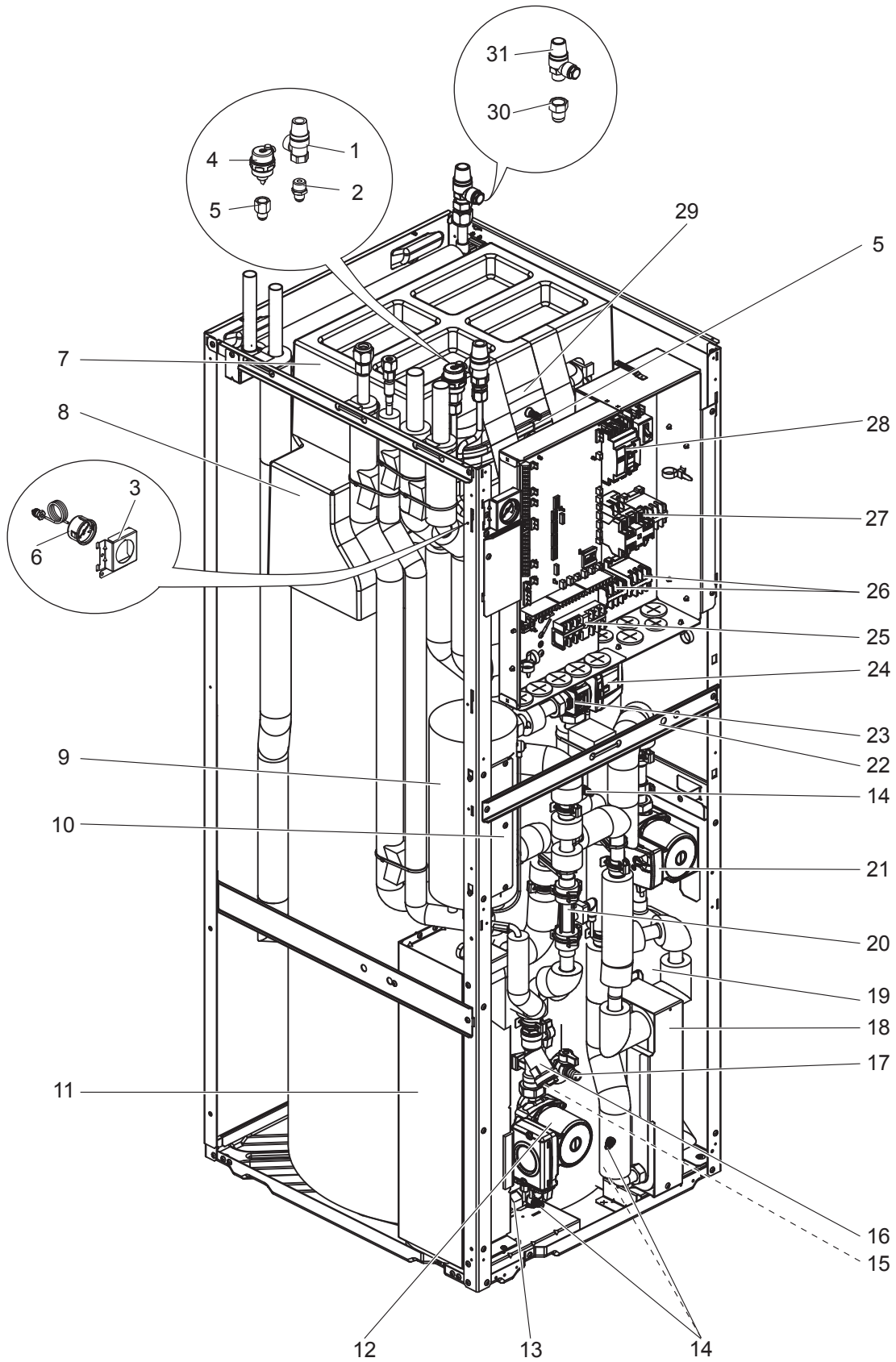

RoHS PARTS LIST

No.	RoHS	Parts No.	Parts name	Specification	Q'ty/unit					Remarks	Wiring diagram symbol	Required regular replacement (*: Required regular inspection)
					EHST20C-VM2CR2.UK	EHST20C-VM6CR2.UK	EHST20C-VM9CR2.UK	EHST20C-TM9CR2.UK	ERST20C-VM2CR2.UK			
1	G	S70 C21 404	PRESSURE RELIEF VALVE	3bar	1	1	1	1	1			6 years
2	G	S70 C60 096	FLARE JOINT	3/8F-R1/2	1	1	1	1	1			
3	G	S70 C70 206	MANOMETER STAY		1	1	1	1	1			
4	G	S70 C17 150	AIR VENT (AUTOMATIC)		1	1	1	1	1			6 years
5	G	S70 C50 096	FLARE JOINT	3/8F-G3/8	2	2	2	2	2			
6	G	S70 C20 205	MANOMETER		1	1	1	1	1			6 years
7	G	—	EXPANSION VESSEL CUSHION ASSY		1	1	1	1	1	BK00T056G02		
8	G	—	TANK CUSHION TOP ASSY		1	1	1	1	1	BK00T055G03		
9	G	S70 C11 441	BOOSTER HEATER	1 ϕ 230V 2 kW	1				1		BH1	
	G	S70 C12 441	BOOSTER HEATER	1 ϕ 230V 6 kW		1					BH1, BH2	
	G	S70 C13 441	BOOSTER HEATER	3 ϕ 400V 9 kW			1				BH1, BH2	
	G	S70 C14 441	BOOSTER HEATER	3 ϕ 230V 9 kW				1			BH1, BH2	
10	G	—	HEATER STAY		1	1	1	1	1	BK00R873G02		
11	G	S70 C70 408	WATER COIL ASSY (5HP)	MWA2	1	1	1	1	1	REFRIGERANT-WATER		
12	G	S70 C06 355	WATER PUMP		1	1	1	1		FOR PRIMARY CIRCUIT	MP1	20,000hrs (3 years)(*)
	G	S70 C09 355	WATER PUMP						1			
13	G	S70 C20 356	PUMP VALVE		1	1	1	1	1			
14	G	S70 C10 358	DRAIN COCK/AIR VENT (WATER CAP ASSY 320)		4	4	4	4	4	FOR PRIMARY/SANITARY CIRCUIT		6 years
15	G	S70 C28 460	STRAINER PACKING		1	1	1	1	1	FOR STRAINER		
16	G	S70 C20 452	STRAINER VALVE		1	1	1	1	1			
17	G	S70 C15 357	DRAIN COCK		1	1	1	1	1	FOR TANK		
18	G	S70 C80 408	WATER COIL ASSY (W)	CB18-24H	1	1	1	1	1	WATER-WATER		
19	G	S70 C50 357	SCALE TRAP		1	1	1	1	1			
20	G	S70 C74 266	FLOW SENSOR (BODY & CABLE)		1	1	1	1	1			
21	G	S70 C05 355	WATER PUMP		1	1	1	1	1	FOR SANITARY CIRCUIT	MP4	
22	G	—	DIV FRAME H DWG		1	1	1	1	1	BK02N520G03		
23	G	S70 C24 406	3WAY VALVE (DIVERTING VALVE)		1	1	1	1	1			
24	G	S70 C25 762	3WAY VALVE (DIVERTING MOTOR)		1	1	1	1	1		3WV	
25	G	S70 C20 515	TERMINAL BED	6P	1	1	1	1	1	(#250LNE+S123)		
26	G	S70 C39 708	CONTACTOR	30A	1	2	2	2	1		BHC1, BHC2	
27	G	S70 C39 708	CONTACTOR	30A	1		1		1		BHCP	
	G	S70 C29 708	CONTACTOR	45A		1		1			BHCP	
28	G	S70 C20 239	EARTH LEAKAGE BREAKER	1 ϕ 20A	1				1		ECB1	
	G	S70 C60 239	EARTH LEAKAGE BREAKER	1 ϕ 40A		1					ECB1	
	G	S70 C70 239	EARTH LEAKAGE BREAKER	3 ϕ 30A			1	1			ECB1	
29	G	S70 C15 402	EXPANSION VESSEL	12L	1	1	1	1	1			
30	G	S70 C70 096	FLARE JOINT	5/8F-R1/2	1	1	1	1	1			
31	G	S70 C30 404	PRESSURE RELIEF VALVE	10bar	1	1	1	1	1	FOR SANITARY SIDE		
(32)	G	S70 C23 460	O-RING	BLACK	10	10	10	10	10			
(33)	G	S70 C26 460	O-RING	BLACK	2	2	2	2	2	FOR FLOW SENSOR		
(34)	G	S70 C10 465	FASTENER		10	10	10	10	10	FOR QUICK CONNECTION		
(35)	G	S70 C20 465	FASTENER		2	2	2	2	2	FOR FLOW SENSOR		
(36)	G	S70 C01 800	GREASE	100 g	12*	12*	12*	12*	12*	FOR QUICK CONNECTION		

Parts number that is circled is not shown in the figure.

Do not reuse the O-ring or strainer packing that was once removed, but be sure to replace with a new one.

* Apply grease appropriately on the O-ring for the quick connection in the unit.

RoHS PARTS LIST

EHST20C-VM2EC.UK
 EHST20C-VM2ECR1.UK
 EHST20C-MEC.UK
 EHST20C-MECR1.UK

EHST20C-VM6EC.UK
 EHST20C-VM6ECR1.UK
 ERST20C-MEC.UK
 ERST20C-MECR1.UK

EHST20C-YM9EC.UK
 EHST20C-YM9ECR1.UK

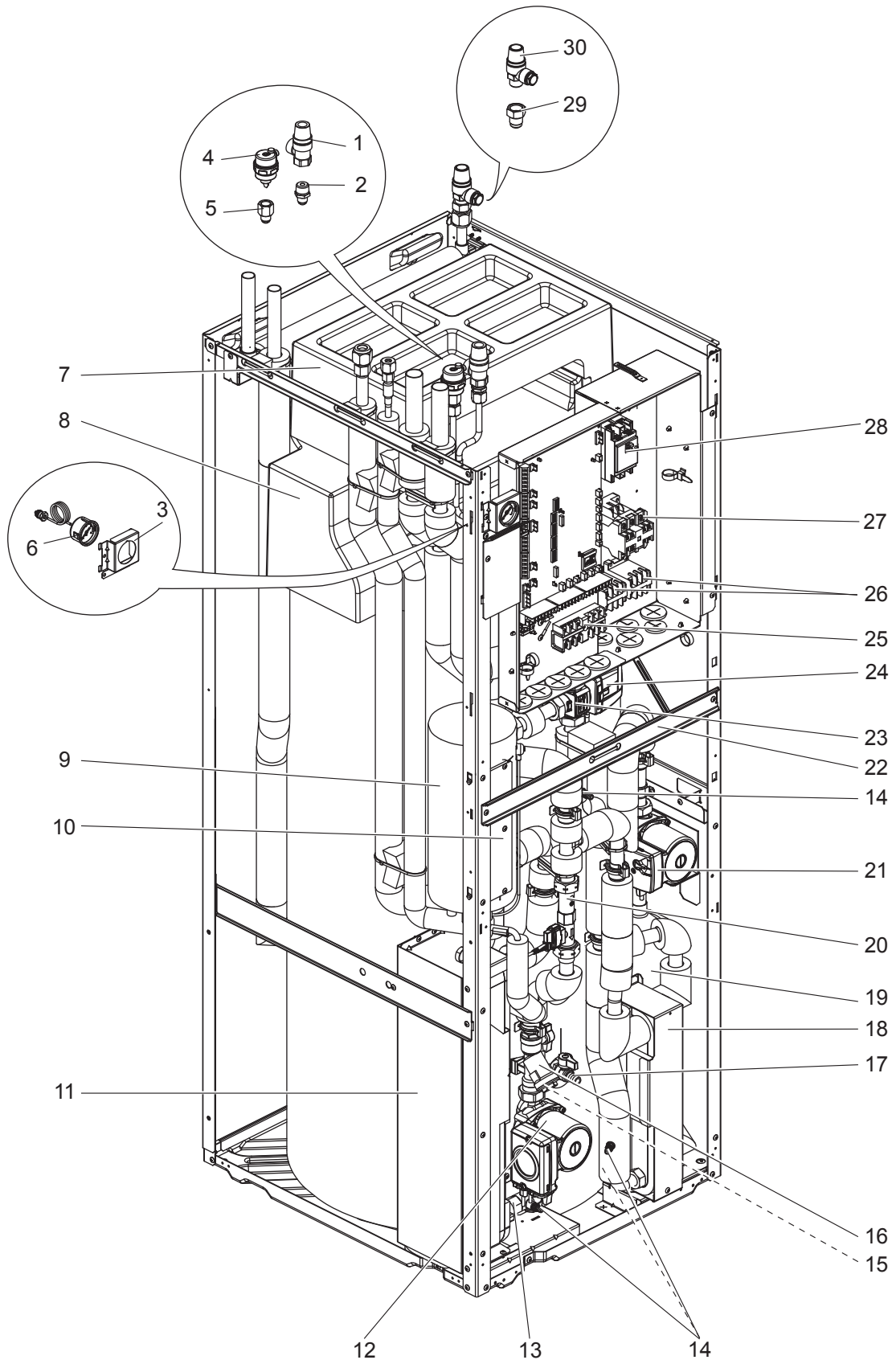

RoHS PARTS LIST

No.	RoHS	Parts No.	Parts name	Specification	Q'ty/unit					Remarks	Wiring diagram symbol	Required regular replacement (*: Required regular inspection)
					EHST20C-VM2EC(R1).UK	EHST20C-VM6EC(R1).UK	EHST20C-VM9EC(R1).UK	EHST20C-MEC(R1).UK	ERST20C-MEC(R1).UK			
1	G	S70 C21 404	PRESSURE RELIEF VALVE	3bar	1	1	1	1	1			6 years
2	G	S70 C60 096	FLARE JOINT	3/8F-R1/2	1	1	1	1	1			
3	G	S70 C50 206	MANOMETER STAY		1	1	1	1	1			
4	G	S70 C17 150	AIR VENT (AUTOMATIC)		1	1	1	1	1			6 years
5	G	S70 C50 096	FLARE JOINT	3/8F-G3/8	1	1	1	1	1			
6	G	S70 C20 205	MANOMETER		1	1	1	1	1			6 years
7	G	—	EXPANSION VESSEL CUSHION		1	1	1	1	1	BK25Y363G02		
8	G	—	TANK CUSHION TOP		1	1	1	1	1	BK25Y362G02		
9	G	S70 C11 441	BOOSTER HEATER	1 ϕ 230V 2 kW	1						BH1	
	G	S70 C12 441	BOOSTER HEATER	1 ϕ 230V 6 kW		1					BH1, BH2	
	G	S70 C13 441	BOOSTER HEATER	3 ϕ 400V 9 kW			1				BH1, BH2	
	G	S70 C15 441	BOOSTER HEATER	0 kW				1	1			
10	G	—	HEATER STAY		1	1	1	1	1	BK00R873G02		
11	G	S70 C70 408	WATER COIL ASSY (5HP)	MWA2	1	1	1	1	1	REFRIGERANT-WATER		
12	G	S70 C06 355	WATER PUMP		1	1	1	1		FOR PRIMARY CIRCUIT	MP1	20,000hrs (3 years)(*)
	G	S70 C09 355	WATER PUMP					1				
13	G	S70 C20 356	PUMP VALVE		1	1	1	1	1			
14	G	S70 C10 358	DRAIN COCK/AIR VENT (WATER CAP ASSY 320)		4	4	4	4	4	FOR PRIMARY/SANITARY CIRCUIT		6 years
15	G	S70 C28 460	STRAINER PACKING		1	1	1	1	1	FOR STRAINER		
16	G	S70 C20 452	STRAINER VALVE		1	1	1	1	1			
17	G	S70 C15 357	DRAIN COCK		1	1	1	1	1	FOR TANK		
18	G	S70 C80 408	WATER COIL ASSY (W)	CB18-24H	1	1	1	1	1	WATER-WATER		
19	G	S70 C50 357	SCALE TRAP		1	1	1	1	1			
20	G	S70 C44 266	FLOW SENSOR (BODY & CABLE)		1	1	1	1	1			
21	G	S70 C05 355	WATER PUMP		1	1	1	1	1	FOR SANITARY CIRCUIT	MP4	
22	G	—	DIV FRAME H DWG		1	1	1	1	1	BK00T057G01		
23	G	S70 C24 406	3WAY VALVE (DIVERTING VALVE)		1	1	1	1	1			
24	G	S70 C25 762	3WAY VALVE (DIVERTING MOTOR)		1	1	1	1	1		3WV	
25	G	S70 C20 515	TERMINAL BED	6P	1	1	1	1	1	(#250LNE+S123)		
26	G	S70 C39 708	CONTACTOR	30A	1	2	2				BHC1, BHC2	
27	G	S70 C39 708	CONTACTOR	30A	1		1				BHCP	
	G	S70 C29 708	CONTACTOR	45A		1					BHCP	
28	G	S70 C20 239	EARTH LEAKAGE BREAKER	1 ϕ 20A	1						ECB1	
	G	S70 C60 239	EARTH LEAKAGE BREAKER	1 ϕ 40A		1					ECB1	
	G	S70 C70 239	EARTH LEAKAGE BREAKER	3 ϕ 30A			1				ECB1	
29	G	S70 C70 096	FLARE JOINT	5/8F-R1/2	1	1	1	1	1			
30	G	S70 C30 404	PRESSURE RELIEF VALVE	10bar	1	1	1	1	1	FOR SANITARY SIDE		
③①	G	S70 C23 460	O-RING	BLACK	12	12	12	12	12			
③②	G	S70 C10 465	FASTENER		10	10	10	10	10	FOR QUICK CONNECTION		
③③	G	S70 C01 800	GREASE	100 g	10*	10*	10*	10*	10*	FOR QUICK CONNECTION		

Parts number that is circled is not shown in the figure.

Do not reuse the O-ring or strainer packing that was once removed, but be sure to replace with a new one.

* Apply grease appropriately on the O-ring for the quick connection in the unit.

RoHS PARTS LIST

EHST20C-VM2ECR2.UK
EHST20C-MECR2.UK

EHST20C-VM6ECR2.UK
ERST20C-MECR2.UK

EHST20C-YM9ECR2.UK

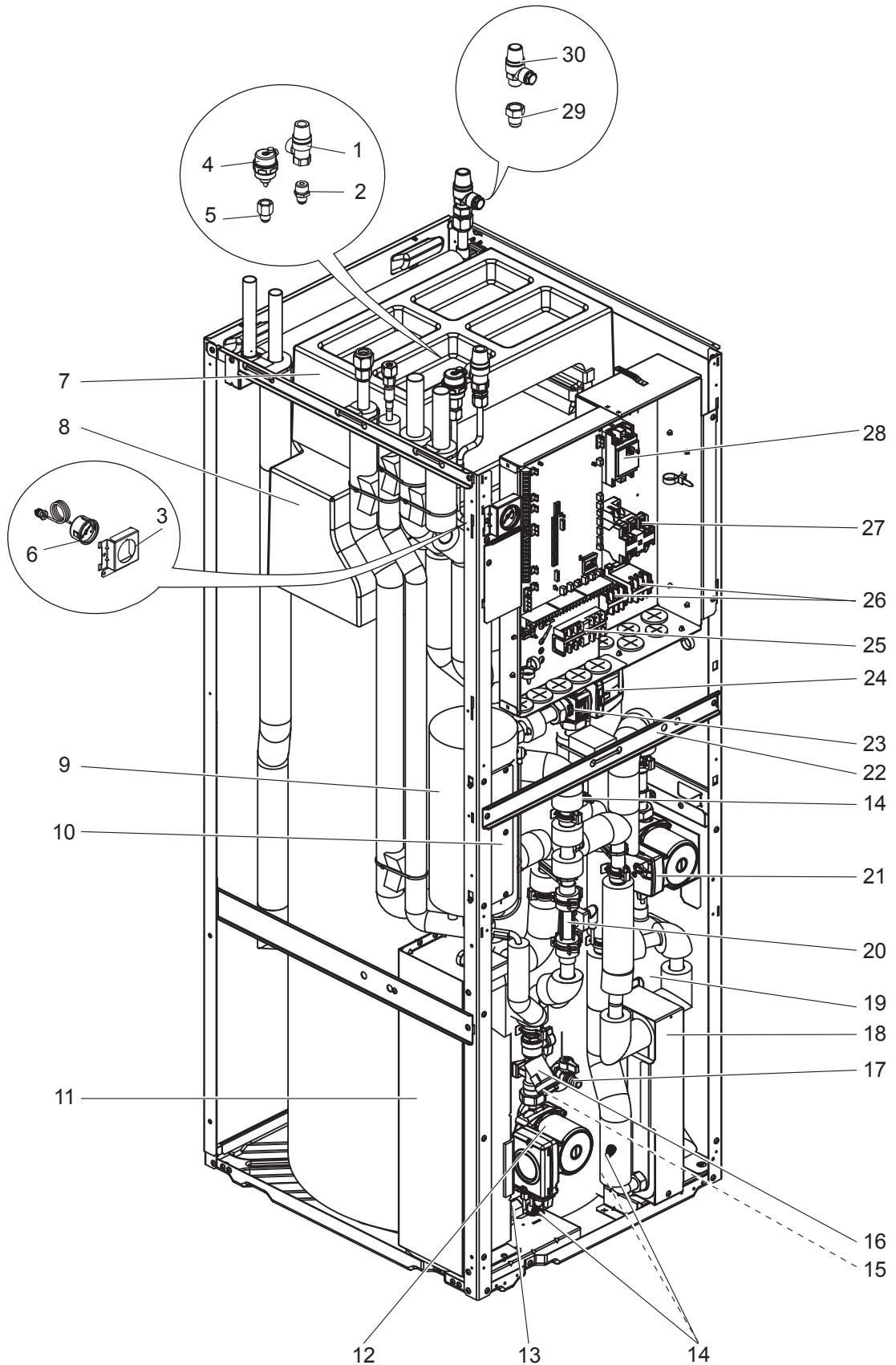

RoHS PARTS LIST

No.	RoHS	Parts No.	Parts name	Specification	Q'ty/unit					Remarks	Wiring diagram symbol	Required regular replacement (*: Required regular inspection)
					EHST20C-VM2ECR2.UK	EHST20C-VM6ECR2.UK	EHST20C-VM9ECR2.UK	EHST20C-MECR2.UK	ERST20C-MECR2.UK			
1	G	S70 C21 404	PRESSURE RELIEF VALVE	3bar	1	1	1	1	1			6 years
2	G	S70 C60 096	FLARE JOINT	3/8F-R1/2	1	1	1	1	1			
3	G	S70 C70 206	MANOMETER STAY		1	1	1	1	1			
4	G	S70 C17 150	AIR VENT (AUTOMATIC)		1	1	1	1	1			6 years
5	G	S70 C50 096	FLARE JOINT	3/8F-G3/8	1	1	1	1	1			
6	G	S70 C20 205	MANOMETER		1	1	1	1	1			6 years
7	G	—	EXPANSION VESSEL CUSHION		1	1	1	1	1	BK25Y363G02		
8	G	—	TANK CUSHION TOP		1	1	1	1	1	BK25Y362G02		
9	G	S70 C11 441	BOOSTER HEATER	1 ϕ 230V 2 kW	1						BH1	
	G	S70 C12 441	BOOSTER HEATER	1 ϕ 230V 6 kW		1					BH1, BH2	
	G	S70 C13 441	BOOSTER HEATER	3 ϕ 400V 9 kW			1				BH1, BH2	
	G	S70 C15 441	BOOSTER HEATER	0 kW				1	1			
10	G	—	HEATER STAY		1	1	1	1	1	BK00R873G02		
11	G	S70 C70 408	WATER COIL ASSY (5HP)	MWA2	1	1	1	1	1	REFRIGERANT-WATER		
12	G	S70 C06 355	WATER PUMP		1	1	1	1		FOR PRIMARY CIRCUIT	MP1	20,000hrs (3 years)(*)
	G	S70 C09 355	WATER PUMP						1			
13	G	S70 C20 356	PUMP VALVE		1	1	1	1	1			
14	G	S70 C10 358	DRAIN COCK/AIR VENT (WATER CAP ASSY 320)		4	4	4	4	4	FOR PRIMARY/SANITARY CIRCUIT		6 years
15	G	S70 C28 460	STRAINER PACKING		1	1	1	1	1	FOR STRAINER		
16	G	S70 C20 452	STRAINER VALVE		1	1	1	1	1			
17	G	S70 C15 357	DRAIN COCK		1	1	1	1	1	FOR TANK		
18	G	S70 C80 408	WATER COIL ASSY (W)	CB18-24H	1	1	1	1	1	WATER-WATER		
19	G	S70 C50 357	SCALE TRAP		1	1	1	1	1			
20	G	S70 C74 266	FLOW SENSOR (BODY & CABLE)		1	1	1	1	1			
21	G	S70 C05 355	WATER PUMP		1	1	1	1	1	FOR SANITARY CIRCUIT	MP4	
22	G	—	DIV FRAME H DWG		1	1	1	1	1	BK02N520G03		
23	G	S70 C24 406	3WAY VALVE (DIVERTING VALVE)		1	1	1	1	1			
24	G	S70 C25 762	3WAY VALVE (DIVERTING MOTOR)		1	1	1	1	1		3WV	
25	G	S70 C20 515	TERMINAL BED	6P	1	1	1	1	1	(#250LNE+S123)		
26	G	S70 C39 708	CONTACTOR	30A	1	2	2				BHC1, BHC2	
27	G	S70 C39 708	CONTACTOR	30A	1		1				BHCP	
	G	S70 C29 708	CONTACTOR	45A		1					BHCP	
28	G	S70 C20 239	EARTH LEAKAGE BREAKER	1 ϕ 20A	1						ECB1	
	G	S70 C60 239	EARTH LEAKAGE BREAKER	1 ϕ 40A		1					ECB1	
	G	S70 C70 239	EARTH LEAKAGE BREAKER	3 ϕ 30A			1				ECB1	
29	G	S70 C70 096	FLARE JOINT	5/8F-R1/2	1	1	1	1	1			
30	G	S70 C30 404	PRESSURE RELIEF VALVE	10bar	1	1	1	1	1	FOR SANITARY SIDE		
31	G	S70 C23 460	O-RING	BLACK	10	10	10	10	10			
32	G	S70 C26 460	O-RING	BLACK	2	2	2	2	2	FOR FLOW SENSOR		
33	G	S70 C10 465	FASTENER		10	10	10	10	10	FOR QUICK CONNECTION		
34	G	S70 C20 465	FASTENER		2	2	2	2	2	FOR FLOW SENSOR		
35	G	S70 C01 800	GREASE	100 g	12*	12*	12*	12*	12*	FOR QUICK CONNECTION		

Parts number that is circled is not shown in the figure.

Do not reuse the O-ring or strainer packing that was once removed, but be sure to replace with a new one.

* Apply grease appropriately on the O-ring for the quick connection in the unit.

RoHS PARTS LIST

EHST20C-MHCW.UK
EHST20C-MHCWR1.UK

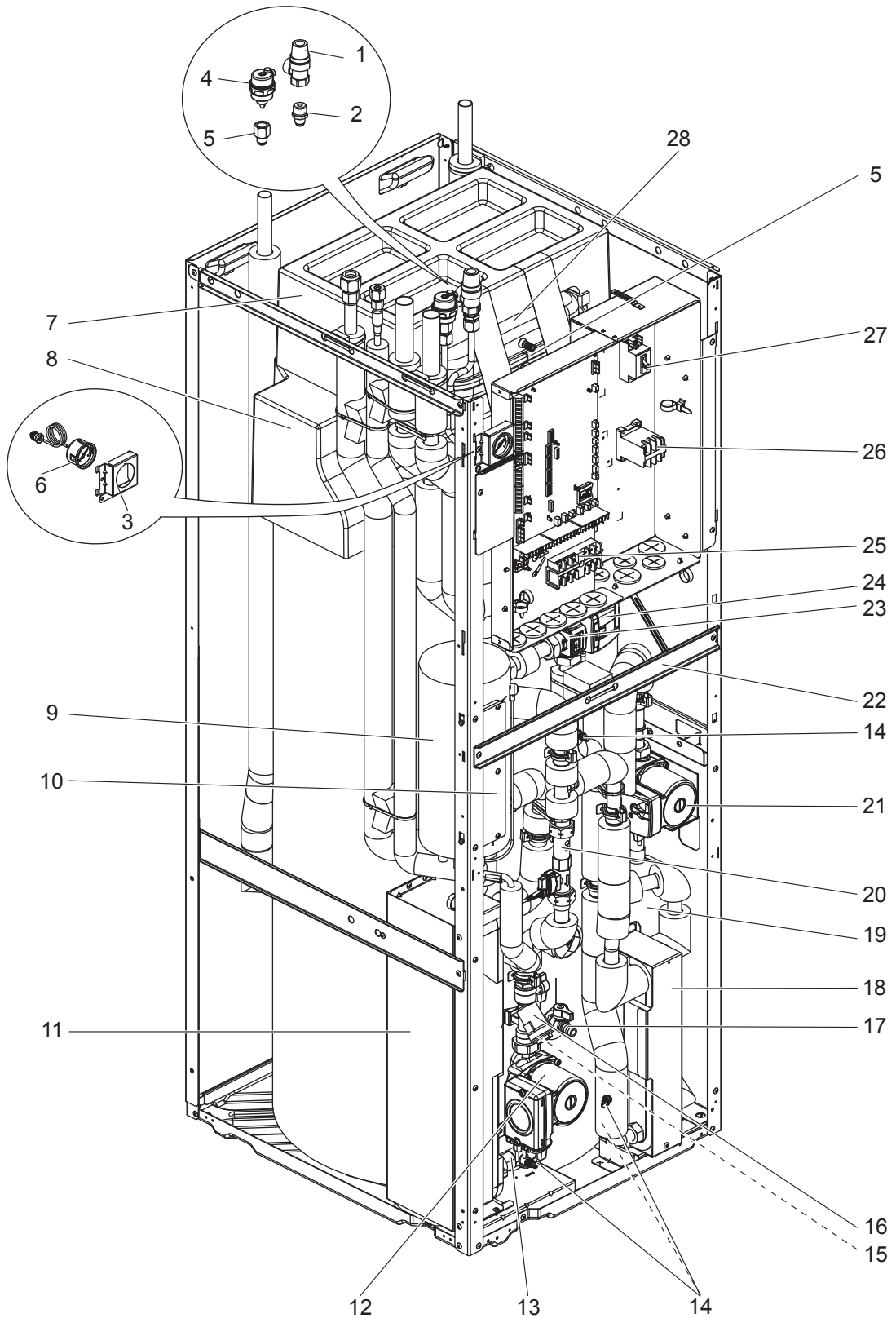

RoHS PARTS LIST

No.	RoHS	Parts No.	Parts name	Specification	Q'ty/unit	Remarks	Wiring diagram symbol	Required regular replacement (*: Required regular inspection)
					EHST20C-MHCW(R1).UK			
1	G	S70 C21 404	PRESSURE RELIEF VALVE	3bar	1			6 years
2	G	S70 C60 096	FLARE JOINT	3/8F-R1/2	1			
3	G	S70 C50 206	MANOMETER STAY		1			
4	G	S70 C17 150	AIR VENT (AUTOMATIC)		1			6 years
5	G	S70 C50 096	FLARE JOINT	3/8F-G3/8	2			
6	G	S70 C20 205	MANOMETER		1			6 years
7	G	—	EXPANSION VESSEL CUSHION ASSY		1	BK00T056G02		
8	G	—	TANK CUSHION TOP ASSY		1	BK00T055G03		
9	G	S70 C15 441	BOOSTER HEATER	0 kW	1			
10	G	—	HEATER STAY		1	BK00R873G02		
11	G	S70 C70 408	WATER COIL ASSY (5HP)	MWA2	1	REFRIGERANT-WATER		
12	G	S70 C06 355	WATER PUMP		1	FOR PRIMARY CIRCUIT	MP1	20,000hrs (3 years)(*)
13	G	S70 C20 356	PUMP VALVE		1			
14	G	S70 C10 358	DRAIN COCK/AIR VENT (WATER CAP ASSY 320)		4	FOR PRIMARY/SANITARY CIRCUIT		6 years
15	G	S70 C28 460	STRAINER PACKING		1	FOR STRAINER		
16	G	S70 C20 452	STRAINER VALVE		1			
17	G	S70 C15 357	DRAIN COCK		1	FOR TANK		
18	G	S70 C80 408	WATER COIL ASSY (W)	CB18-24H	1	WATER-WATER		
19	G	S70 C50 357	SCALE TRAP		1			
20	G	S70 C44 266	FLOW SENSOR (BODY & CABLE)		1			
21	G	S70 C05 355	WATER PUMP		1	FOR SANITARY CIRCUIT	MP4	
22	G	—	DIV FRAME H DWG		1	BK00T057G01		
23	G	S70 C24 406	3WAY VALVE (DIVERTING VALVE)		1			
24	G	S70 C25 762	3WAY VALVE (DIVERTING MOTOR)		1		3WV	
25	G	S70 C20 515	TERMINAL BED	6P	1	(#250LNE+S123)		
26	G	S70 C39 708	CONTACTOR	30A	1		IHC	
27	G	S70 C20 239	EARTH LEAKAGE BREAKER	1 ϕ 20A	1		ECB2	
28	G	S70 C15 402	EXPANSION VESSEL	12L	1			
29	G	S70 C27 460	O-RING	ORANGE	3	FOR SANITARY SIDE		
30	G	S70 C23 460	O-RING	BLACK	10			
31	G	S70 C10 465	FASTENER		11	FOR QUICK CONNECTION		
32	G	S70 C01 800	GREASE	100 g	11 *	FOR QUICK CONNECTION		

Parts number that is circled is not shown in the figure.

Do not reuse the O-ring or strainer packing that was once removed, but be sure to replace with a new one.

* Apply grease appropriately on the O-ring for the quick connection in the unit.

RoHS PARTS LIST

EHST20C-MHCWR2.UK

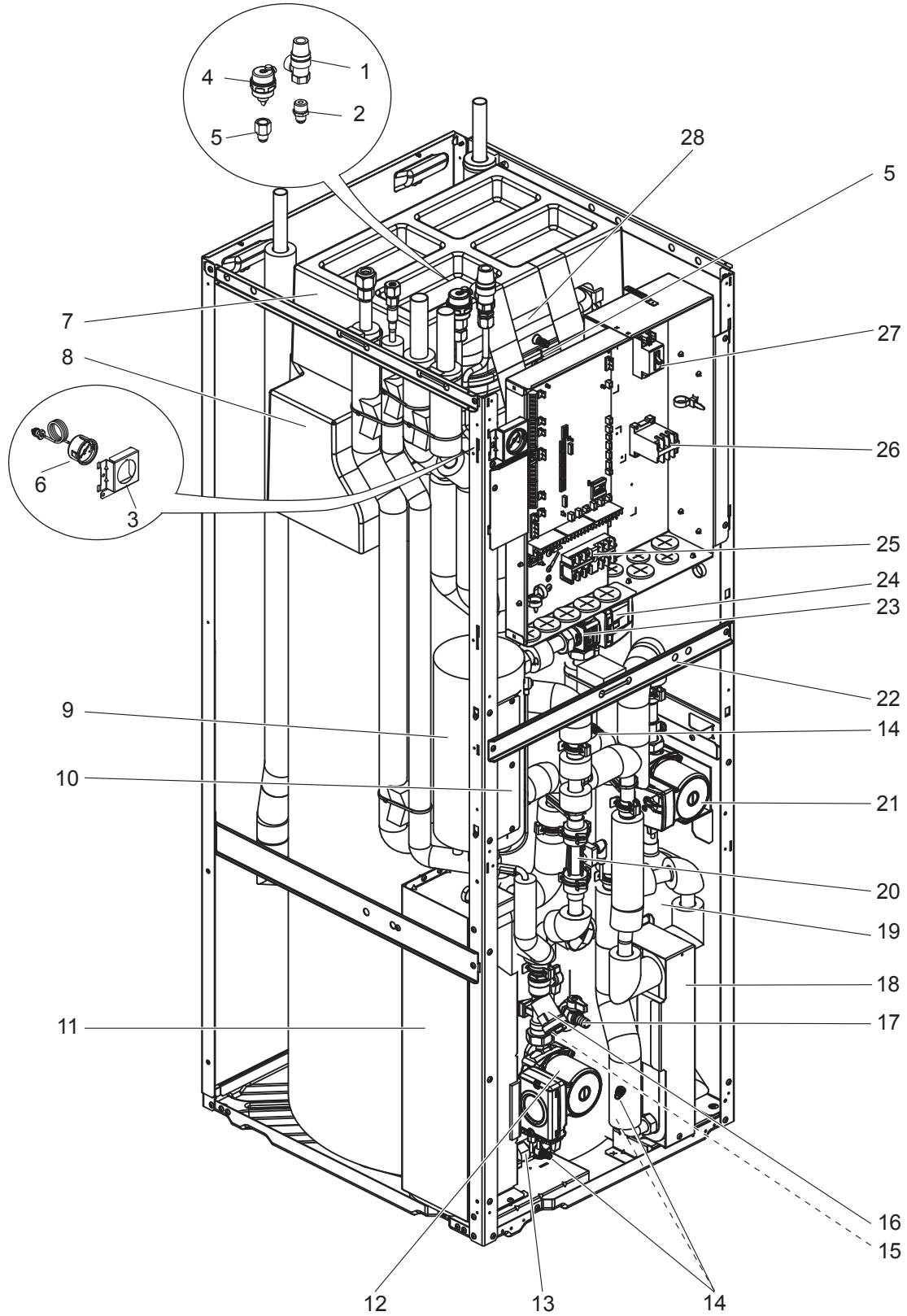

RoHS PARTS LIST

No.	RoHS	Parts No.	Parts name	Specification	Q'ty/unit	Remarks	Wiring diagram symbol	Required regular replacement (*: Required regular inspection)
					EHST20C-MHCWR2.UK			
1	G	S70 C21 404	PRESSURE RELIEF VALVE	3bar	1			6 years
2	G	S70 C60 096	FLARE JOINT	3/8F-R1/2	1			
3	G	S70 C70 206	MANOMETER STAY		1			
4	G	S70 C17 150	AIR VENT (AUTOMATIC)		1			6 years
5	G	S70 C50 096	FLARE JOINT	3/8F-G3/8	2			
6	G	S70 C20 205	MANOMETER		1			6 years
7	G	—	EXPANSION VESSEL CUSHION ASSY		1	BK00T056G02		
8	G	—	TANK CUSHION TOP ASSY		1	BK00T055G03		
9	G	S70 C15 441	BOOSTER HEATER	0 kW	1			
10	G	—	HEATER STAY		1	BK00R873G02		
11	G	S70 C70 408	WATER COIL ASSY (5HP)	MWA2	1	REFRIGERANT-WATER		
12	G	S70 C06 355	WATER PUMP		1	FOR PRIMARY CIRCUIT	MP1	20,000hrs (3 years)(*)
13	G	S70 C20 356	PUMP VALVE		1			
14	G	S70 C10 358	DRAIN COCK/AIR VENT (WATER CAP ASSY 320)		4	FOR PRIMARY/SANITARY CIRCUIT		6 years
15	G	S70 C28 460	STRAINER PACKING		1	FOR STRAINER		
16	G	S70 C20 452	STRAINER VALVE		1			
17	G	S70 C15 357	DRAIN COCK		1	FOR TANK		
18	G	S70 C80 408	WATER COIL ASSY (W)	CB18-24H	1	WATER-WATER		
19	G	S70 C50 357	SCALE TRAP		1			
20	G	S70 C74 266	FLOW SENSOR (BODY & CABLE)		1			
21	G	S70 C05 355	WATER PUMP		1	FOR SANITARY CIRCUIT	MP4	
22	G	—	DIV FRAME H DWG		1	BK02N520G03		
23	G	S70 C24 406	3WAY VALVE (DIVERTING VALVE)		1			
24	G	S70 C25 762	3WAY VALVE (DIVERTING MOTOR)		1		3WV	
25	G	S70 C20 515	TERMINAL BED	6P	1	(#250LNE+S123)		
26	G	S70 C39 708	CONTACTOR	30A	1		IHC	
27	G	S70 C20 239	EARTH LEAKAGE BREAKER	1 ϕ 20A	1		ECB2	
28	G	S70 C15 402	EXPANSION VESSEL	12L	1			
29	G	S70 C27 460	O-RING	ORANGE	3	FOR SANITARY SIDE		
30	G	S70 C23 460	O-RING	BLACK	8			
31	G	S70 C26 460	O-RING	BLACK	2	FOR FLOW SENSOR		
32	G	S70 C10 465	FASTENER		11	FOR QUICK CONNECTION		
33	G	S70 C20 465	FASTENER		2	FOR FLOW SENSOR		
34	G	S70 C01 800	GREASE	100 g	13 *	FOR QUICK CONNECTION		

Parts number that is circled is not shown in the figure.

Do not reuse the O-ring or strainer packing that was once removed, but be sure to replace with a new one.

* Apply grease appropriately on the O-ring for the quick connection in the unit.

RoHS PARTS LIST

EHST20D-VM2C.UK
 EHST20D-VM2CR1.UK
 ERST20D-VM2C.UK
 ERST20D-VM2CR1.UK

EHST20D-MHC.UK
 EHST20D-MHCR1.UK

EHST20D-YM9C.UK
 EHST20D-YM9CR1.UK

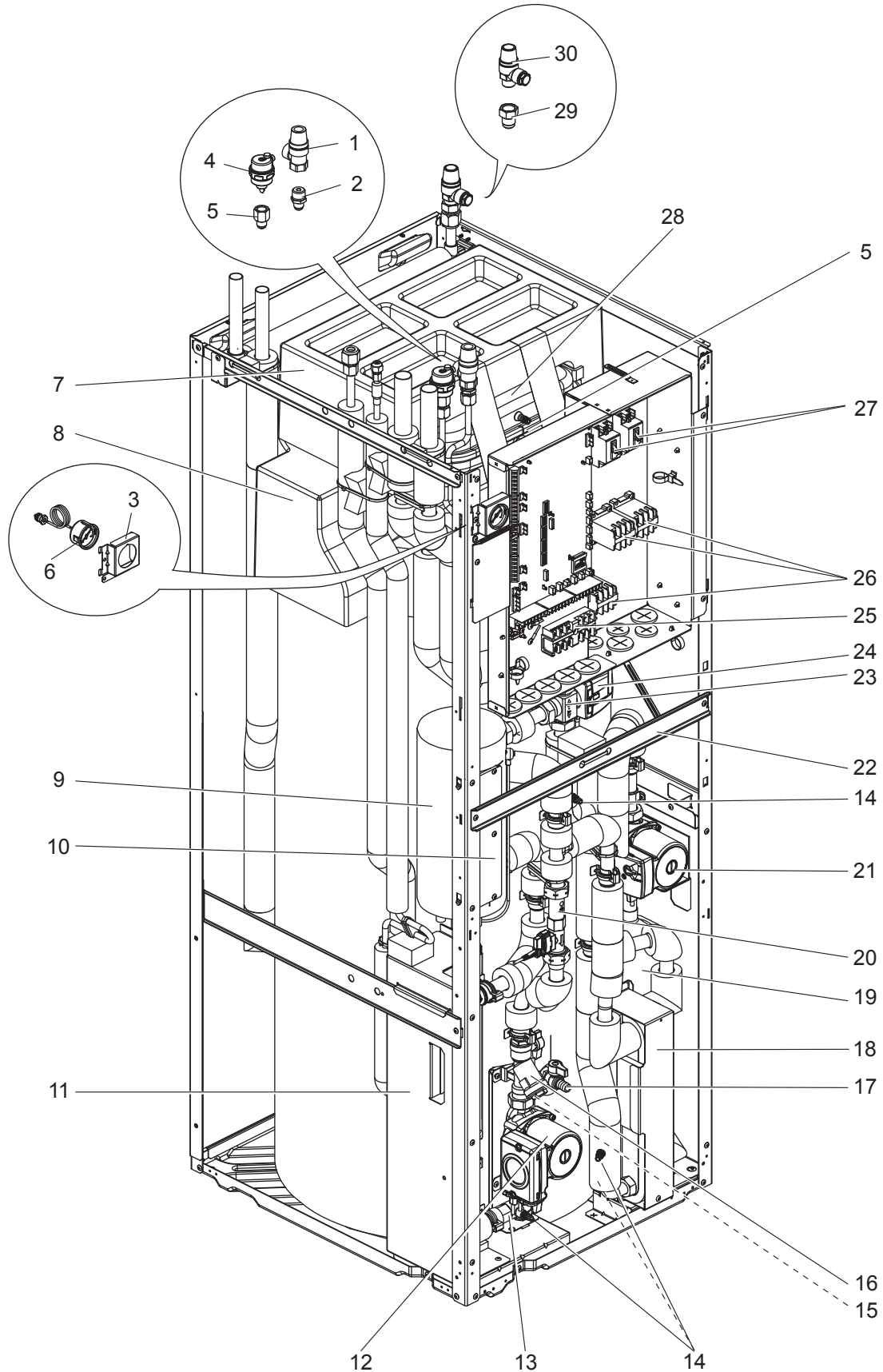

RoHS PARTS LIST

No.	RoHS	Parts No.	Parts name	Specification	Q'ty/unit				Remarks	Wiring diagram symbol	Required regular replacement (*: Required regular inspection)
					EHST20D-VM2C(R1).UK	EHST20D-MHC(R1).UK	EHST20D-YM9C(R1).UK	ERST20D-VM2C(R1).UK			
1	G	S70 C21 404	PRESSURE RELIEF VALVE	3bar	1	1	1	1			6 years
2	G	S70 C60 096	FLARE JOINT	3/8F-R1/2	1	1	1	1			
3	G	S70 C50 206	MANOMETER STAY		1	1	1	1			
4	G	S70 C17 150	AIR VENT (AUTOMATIC)		1	1	1	1			6 years
5	G	S70 C50 096	FLARE JOINT	3/8F-G3/8	2	2	2	2			
6	G	S70 C20 205	MANOMETER		1	1	1	1			6 years
7	G	—	EXPANSION VESSEL CUSHION ASSY		1	1	1	1	BK00T056G02		
8	G	—	TANK CUSHION TOP ASSY		1	1	1	1	BK00T055G03		
9	G	S70 C11 441	BOOSTER HEATER	1 ϕ 230V 2 kW	1			1		BH1	
	G	S70 C15 441	BOOSTER HEATER	0 kW		1					
	G	S70 C13 441	BOOSTER HEATER	3 ϕ 400V 9 kW			1			BH1, BH2	
10	G	—	HEATER STAY		1	1	1	1	BK00R873G02		
11	G	S70 C60 408	WATER COIL ASSY (2HP)	MWA1	1	1	1	1	REFRIGERANT-WATER		
12	G	S70 C06 355	WATER PUMP		1	1	1		FOR PRIMARY CIRCUIT	MP1	20,000hrs (3 years)(*)
	G	S70 C09 355	WATER PUMP					1			
13	G	S70 C20 356	PUMP VALVE		1	1	1	1			
14	G	S70 C10 358	DRAIN COCK/AIR VENT (WATER CAP ASSY 320)		4	4	4	4	FOR PRIMARY/SANITARY CIRCUIT		6 years
15	G	S70 C28 460	STRAINER PACKING		1	1	1	1	FOR STRAINER		
16	G	S70 C20 452	STRAINER VALVE		1	1	1	1			
17	G	S70 C15 357	DRAIN COCK		1	1	1	1	FOR TANK		
18	G	S70 C80 408	WATER COIL ASSY (W)	CB18-24H	1	1	1	1	WATER-WATER		
19	G	S70 C50 357	SCALE TRAP		1	1	1	1			
20	G	S70 C44 266	FLOW SENSOR (BODY & CABLE)		1	1	1	1			
21	G	S70 C05 355	WATER PUMP		1	1	1	1	FOR SANITARY CIRCUIT	MP4	
22	G	—	DIV FRAME H DWG		1	1	1	1	BK00T057G01		
23	G	S70 C24 406	3WAY VALVE (DIVERTING VALVE)		1	1	1	1			
24	G	S70 C25 762	3WAY VALVE (DIVERTING MOTOR)		1	1	1	1		3WV	
25	G	S70 C20 515	TERMINAL BED	6P	1	1	1	1	(#250LNE+S123)		
26	G	S70 C39 708	CONTACTOR	30A	2	1	3	2		BHCP, BHC1, IHC	
27	G	S70 C20 239	EARTH LEAKAGE BREAKER	1 ϕ 20A	1	1		1		ECB1, ECB2	
	G	S70 C70 239	EARTH LEAKAGE BREAKER	3 ϕ 30A			1			ECB1	
28	G	S70 C15 402	EXPANSION VESSEL	12L	1	1	1	1			
29	G	S70 C70 096	FLARE JOINT	5/8F-R1/2	1	1	1	1			
30	G	S70 C30 404	PRESSURE RELIEF VALVE	10bar	1	1	1	1	FOR SANITARY SIDE		
31	G	S70 C23 460	O-RING	BLACK	15	15	15	15			
32	G	S70 C10 465	FASTENER		13	13	13	13	FOR QUICK CONNECTION		
33	G	S70 C01 800	GREASE	100 g	13*	13*	13*	13*	FOR QUICK CONNECTION		

Parts number that is circled is not shown in the figure.

Do not reuse the O-ring or strainer packing that was once removed, but be sure to replace with a new one.

* Apply grease appropriately on the O-ring for the quick connection in the unit.

RoHS PARTS LIST

EHST20D-VM2CR2.UK
ERST20D-VM2CR2.UK

EHST20D-MHCR2.UK

EHST20D-YM9CR2.UK

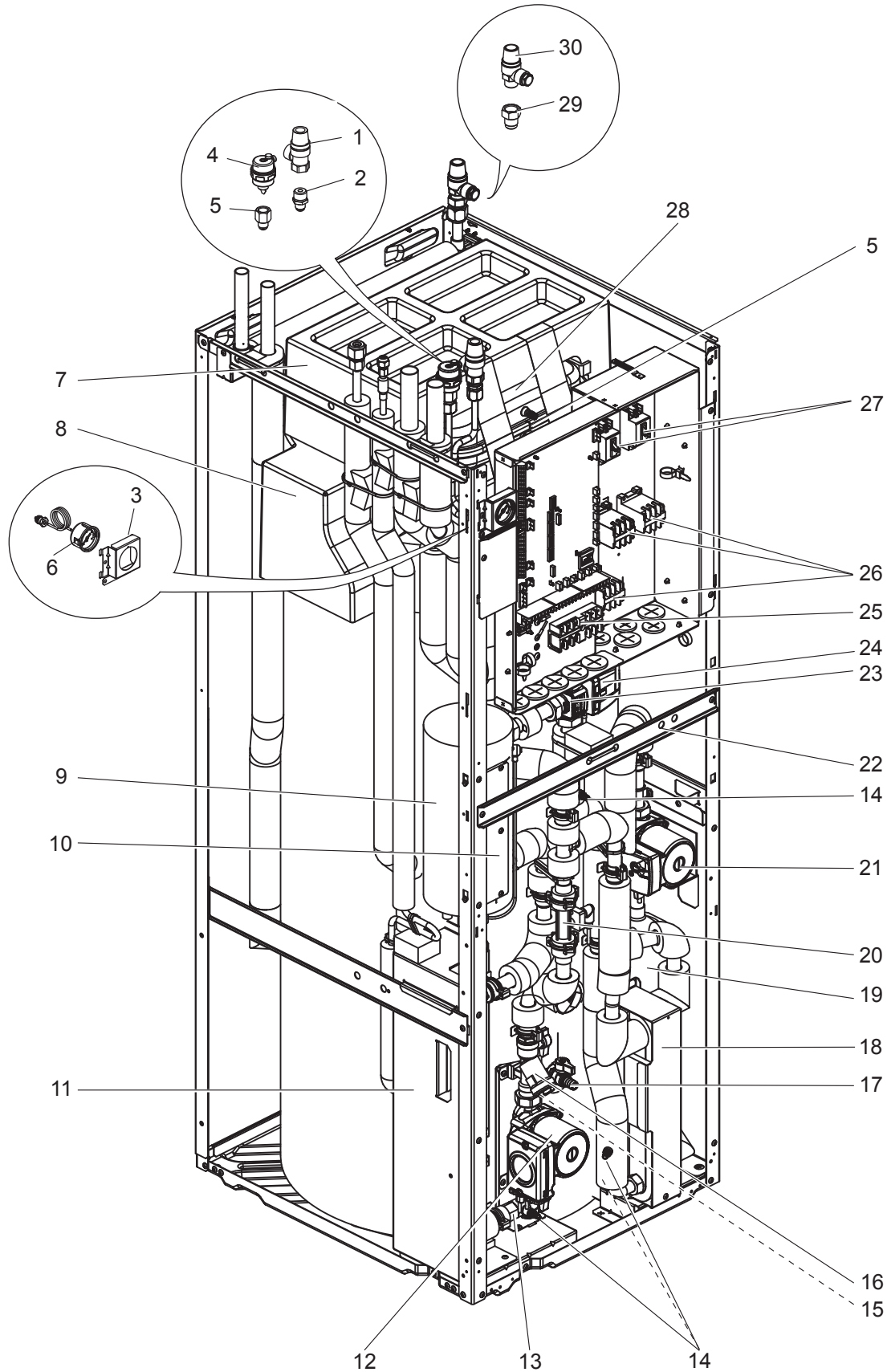

RoHS PARTS LIST

No.	RoHS	Parts No.	Parts name	Specification	Q'ty/unit				Remarks	Wiring diagram symbol	Required regular replacement (*: Required regular inspection)
					EHST20D-VM2CR2.UK	EHST20D-MHCR2.UK	EHST20D-YM9CR2.UK	ERST20D-VM2CR2.UK			
1	G	S70 C21 404	PRESSURE RELIEF VALVE	3bar	1	1	1	1			6 years
2	G	S70 C60 096	FLARE JOINT	3/8F-R1/2	1	1	1	1			
3	G	S70 C70 206	MANOMETER STAY		1	1	1	1			
4	G	S70 C17 150	AIR VENT (AUTOMATIC)		1	1	1	1			6 years
5	G	S70 C50 096	FLARE JOINT	3/8F-G3/8	2	2	2	2			
6	G	S70 C20 205	MANOMETER		1	1	1	1			6 years
7	G	—	EXPANSION VESSEL CUSHION ASSY		1	1	1	1	BK00T056G02		
8	G	—	TANK CUSHION TOP ASSY		1	1	1	1	BK00T055G03		
9	G	S70 C11 441	BOOSTER HEATER	1 ϕ 230V 2 kW	1			1		BH1	
	G	S70 C15 441	BOOSTER HEATER	0 kW		1					
	G	S70 C13 441	BOOSTER HEATER	3 ϕ 400V 9 kW			1			BH1, BH2	
10	G	—	HEATER STAY		1	1	1	1	BK00R873G02		
11	G	S70 C60 408	WATER COIL ASSY (2HP)	MWA1	1	1	1	1	REFRIGERANT-WATER		
12	G	S70 C06 355	WATER PUMP		1	1	1		FOR PRIMARY CIRCUIT	MP1	20,000hrs (3 years)(*)
	G	S70 C09 355	WATER PUMP				1				
13	G	S70 C20 356	PUMP VALVE		1	1	1	1			
14	G	S70 C10 358	DRAIN COCK/AIR VENT (WATER CAP ASSY 320)		4	4	4	4	FOR PRIMARY/SANITARY CIRCUIT		6 years
15	G	S70 C28 460	STRAINER PACKING		1	1	1	1	FOR STRAINER		
16	G	S70 C20 452	STRAINER VALVE		1	1	1	1			
17	G	S70 C15 357	DRAIN COCK		1	1	1	1	FOR TANK		
18	G	S70 C80 408	WATER COIL ASSY (W)	CB18-24H	1	1	1	1	WATER-WATER		
19	G	S70 C50 357	SCALE TRAP		1	1	1	1			
20	G	S70 C74 266	FLOW SENSOR (BODY & CABLE)		1	1	1	1			
21	G	S70 C05 355	WATER PUMP		1	1	1	1	FOR SANITARY CIRCUIT	MP4	
22	G	—	DIV FRAME H DWG		1	1	1	1	BK02N520G03		
23	G	S70 C24 406	3WAY VALVE (DIVERTING VALVE)		1	1	1	1			
24	G	S70 C25 762	3WAY VALVE (DIVERTING MOTOR)		1	1	1	1		3WV	
25	G	S70 C20 515	TERMINAL BED	6P	1	1	1	1	(#250LNE+S123)		
26	G	S70 C39 708	CONTACTOR	30A	2	1	3	2		BHCP, BHC1, IHC	
27	G	S70 C20 239	EARTH LEAKAGE BREAKER	1 ϕ 20A	1	1		1		ECB1, ECB2	
	G	S70 C70 239	EARTH LEAKAGE BREAKER	3 ϕ 30A			1			ECB1	
28	G	S70 C15 402	EXPANSION VESSEL	12L	1	1	1	1			
29	G	S70 C70 096	FLARE JOINT	5/8F-R1/2	1	1	1	1			
30	G	S70 C30 404	PRESSURE RELIEF VALVE	10bar	1	1	1	1	FOR SANITARY SIDE		
③1	G	S70 C23 460	O-RING	BLACK	13	13	13	13			
③2	G	S70 C26 460	O-RING	BLACK	2	2	2	2	FOR FLOW SENSOR		
③3	G	S70 C10 465	FASTENER		13	13	13	13	FOR QUICK CONNECTION		
③4	G	S70 C20 465	FASTENER		2	2	2	2	FOR FLOW SENSOR		
③5	G	S70 C01 800	GREASE	100 g	15*	15*	15*	15*	FOR QUICK CONNECTION		

Parts number that is circled is not shown in the figure.

Do not reuse the O-ring or strainer packing that was once removed, but be sure to replace with a new one.

* Apply grease appropriately on the O-ring for the quick connection in the unit.

RoHS PARTS LIST

EHST20D-VM2EC.UK
EHST20D-VM2ECR1.UK

EHST20D-MEC.UK
EHST20D-MECR1.UK

ERST20D-MEC.UK
ERST20D-MECR1.UK

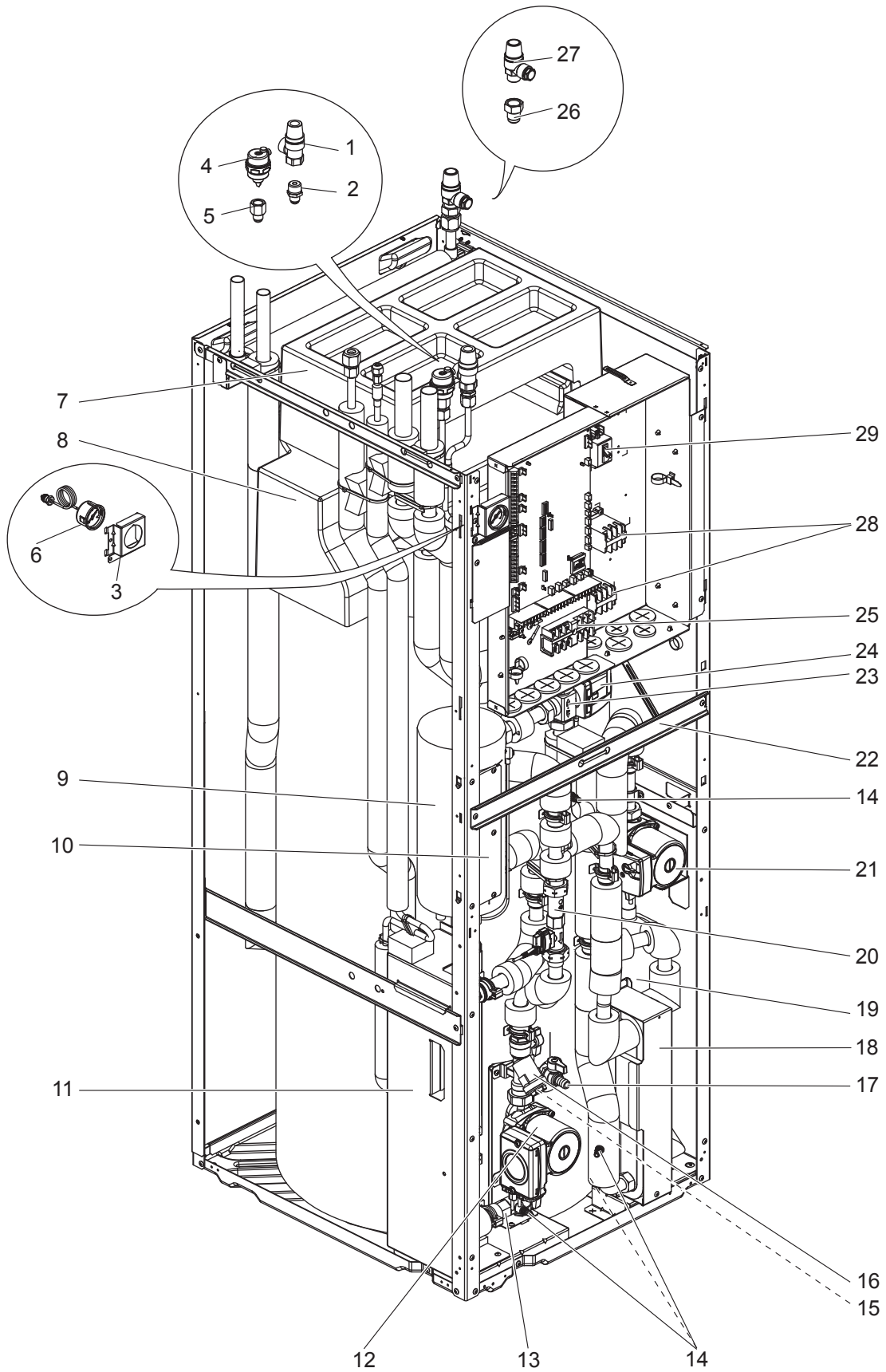

RoHS PARTS LIST

No.	RoHS	Parts No.	Parts name	Specification	Q'ty/unit			Remarks	Wiring diagram symbol	Required regular replacement (*: Required regular inspection)
					EHST20D-VM2EC(R1).UK	EHST20D-MEC(R1).UK	ERST20D-MEC(R1).UK			
1	G	S70 C21 404	PRESSURE RELIEF VALVE	3bar	1	1	1			6 years
2	G	S70 C60 096	FLARE JOINT	3/8F-R1/2	1	1	1			
3	G	S70 C50 206	MANOMETER STAY		1	1	1			
4	G	S70 C17 150	AIR VENT (AUTOMATIC)		1	1	1			6 years
5	G	S70 C50 096	FLARE JOINT	3/8F-G3/8	1	1	1			
6	G	S70 C20 205	MANOMETER		1	1	1			6 years
7	G	—	EXPANSION VESSEL CUSHION		1	1	1	BK25Y363G02		
8	G	—	TANK CUSHION TOP		1	1	1	BK25Y362G02		
9	G	S70 C15 441	BOOSTER HEATER	0 kW		1	1			
	G	S70 C11 441	BOOSTER HEATER	1 ϕ 230V 2 kW	1				BH1	
10	G	—	HEATER STAY		1	1	1	BK00R873G02		
11	G	S70 C60 408	WATER COIL ASSY (2HP)	MWA1	1	1	1	REFRIGERANT-WATER		
12	G	S70 C06 355	WATER PUMP		1	1		FOR PRIMARY CIRCUIT	MP1	20,000hrs (3 years)(*)
	G	S70 C09 355	WATER PUMP				1			
13	G	S70 C20 356	PUMP VALVE		1	1	1			
14	G	S70 C10 358	DRAIN COCK/AIR VENT (WATER CAP ASSY 320)		4	4	4	FOR PRIMARY/SANITARY CIRCUIT		6 years
15	G	S70 C28 460	STRAINER PACKING		1	1	1	FOR STRAINER		
16	G	S70 C20 452	STRAINER VALVE		1	1	1			
17	G	S70 C15 357	DRAIN COCK		1	1	1	FOR TANK		
18	G	S70 C80 408	WATER COIL ASSY (W)	CB18-24H	1	1	1	WATER-WATER		
19	G	S70 C50 357	SCALE TRAP		1	1	1			
20	G	S70 C44 266	FLOW SENSOR (BODY & CABLE)		1	1	1			
21	G	S70 C05 355	WATER PUMP		1	1	1	FOR SANITARY CIRCUIT	MP4	
22	G	—	DIV FRAME H DWG		1	1	1	BK00T057G01		
23	G	S70 C24 406	3WAY VALVE (DIVERTING VALVE)		1	1	1			
24	G	S70 C25 762	3WAY VALVE (DIVERTING MOTOR)		1	1	1		3WV	
25	G	S70 C20 515	TERMINAL BED	6P	1	1	1	(#250LNE+S123)		
26	G	S70 C70 096	FLARE JOINT	5/8F-R1/2	1	1	1			
27	G	S70 C30 404	PRESSURE RELIEF VALVE	10bar	1	1	1	FOR SANITARY SIDE		
28	G	S70 C39 708	CONTACTOR	30A	2				BHCP, BHC1	
29	G	S70 C20 239	EARTH LEAKAGE BREAKER	1 ϕ 20A	1				ECB1	
③⑩	G	S70 C23 460	O-RING	BLACK	15	15	15			
③①	G	S70 C10 465	FASTENER		13	13	13	FOR QUICK CONNECTION		
③②	G	S70 C01 800	GREASE	100 g	13*	13*	13*	FOR QUICK CONNECTION		

Parts number that is circled is not shown in the figure.

Do not reuse the O-ring or strainer packing that was once removed, but be sure to replace with a new one.

* Apply grease appropriately on the O-ring for the quick connection in the unit.

RoHS PARTS LIST

EHST20D-VM2ECR2.UK

EHST20D-MECR2.UK

ERST20D-MECR2.UK

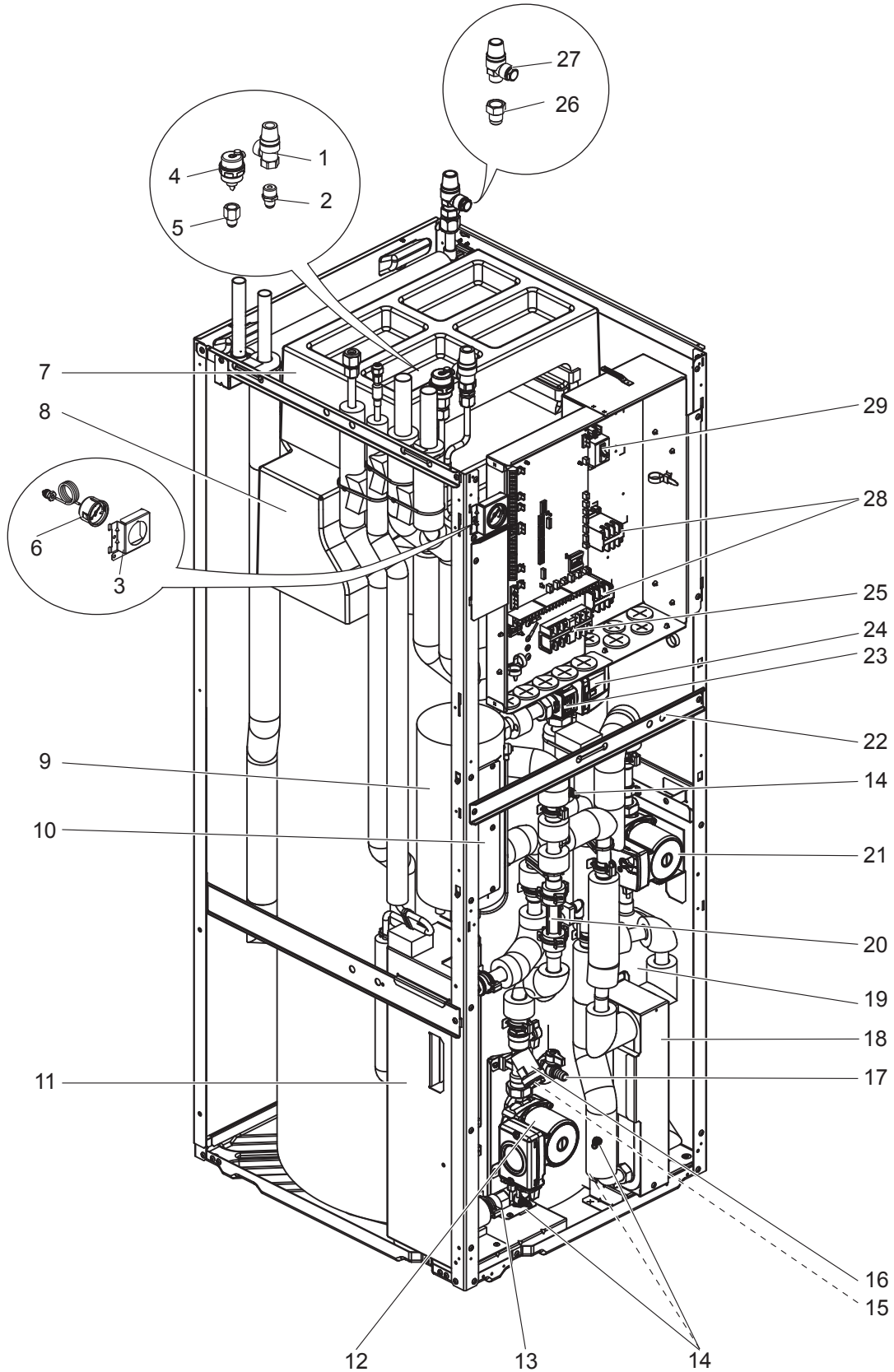

RoHS PARTS LIST

No.	RoHS	Parts No.	Parts name	Specification	Q'ty/unit			Remarks	Wiring diagram symbol	Required regular replacement (*: Required regular inspection)
					EHST20D-VM2ECR2.UK	EHST20D-MECR2.UK	ERST20D-MECR2.UK			
1	G	S70 C21 404	PRESSURE RELIEF VALVE	3bar	1	1	1			6 years
2	G	S70 C60 096	FLARE JOINT	3/8F-R1/2	1	1	1			
3	G	S70 C70 206	MANOMETER STAY		1	1	1			
4	G	S70 C17 150	AIR VENT (AUTOMATIC)		1	1	1			6 years
5	G	S70 C50 096	FLARE JOINT	3/8F-G3/8	1	1	1			
6	G	S70 C20 205	MANOMETER		1	1	1			6 years
7	G	—	EXPANSION VESSEL CUSHION		1	1	1	BK25Y363G02		
8	G	—	TANK CUSHION TOP		1	1	1	BK25Y362G02		
9	G	S70 C15 441	BOOSTER HEATER	0 kW		1	1			
	G	S70 C11 441	BOOSTER HEATER	1 ϕ 230V 2 kW	1				BH1	
10	G	—	HEATER STAY		1	1	1	BK00R873G02		
11	G	S70 C60 408	WATER COIL ASSY (2HP)	MWA1	1	1	1	REFRIGERANT-WATER		
12	G	S70 C06 355	WATER PUMP		1	1		FOR PRIMARY CIRCUIT	MP1	20,000hrs (3 years)(*)
	G	S70 C09 355	WATER PUMP				1			
13	G	S70 C20 356	PUMP VALVE		1	1	1			
14	G	S70 C10 358	DRAIN COCK/AIR VENT (WATER CAP ASSY 320)		4	4	4	FOR PRIMARY/SANITARY CIRCUIT		6 years
15	G	S70 C28 460	STRAINER PACKING		1	1	1	FOR STRAINER		
16	G	S70 C20 452	STRAINER VALVE		1	1	1			
17	G	S70 C15 357	DRAIN COCK		1	1	1	FOR TANK		
18	G	S70 C80 408	WATER COIL ASSY (W)	CB18-24H	1	1	1	WATER-WATER		
19	G	S70 C50 357	SCALE TRAP		1	1	1			
20	G	S70 C74 266	FLOW SENSOR (BODY & CABLE)		1	1	1			
21	G	S70 C05 355	WATER PUMP		1	1	1	FOR SANITARY CIRCUIT	MP4	
22	G	—	DIV FRAME H DWG		1	1	1	BK02N520G03		
23	G	S70 C24 406	3WAY VALVE (DIVERTING VALVE)		1	1	1			
24	G	S70 C25 762	3WAY VALVE (DIVERTING MOTOR)		1	1	1		3WV	
25	G	S70 C20 515	TERMINAL BED	6P	1	1	1	(#250LNE+S123)		
26	G	S70 C70 096	FLARE JOINT	5/8F-R1/2	1	1	1			
27	G	S70 C30 404	PRESSURE RELIEF VALVE	10bar	1	1	1	FOR SANITARY SIDE		
28	G	S70 C39 708	CONTACTOR	30A	2				BHCP, BHC1	
29	G	S70 C20 239	EARTH LEAKAGE BREAKER	1 ϕ 20A	1				ECB1	
30	G	S70 C23 460	O-RING	BLACK	13	13	13			
31	G	S70 C26 460	O-RING	BLACK	2	2	2	FOR FLOW SENSOR		
32	G	S70 C10 465	FASTENER		13	13	13	FOR QUICK CONNECTION		
33	G	S70 C20 465	FASTENER		2	2	2	FOR FLOW SENSOR		
34	G	S70 C01 800	GREASE	100 g	15*	15*	15*	FOR QUICK CONNECTION		

Parts number that is circled is not shown in the figure.

Do not reuse the O-ring or strainer packing that was once removed, but be sure to replace with a new one.

* Apply grease appropriately on the O-ring for the quick connection in the unit.

RoHS PARTS LIST

EHST20D-MHCW.UK
EHST20D-MHCWR1.UK

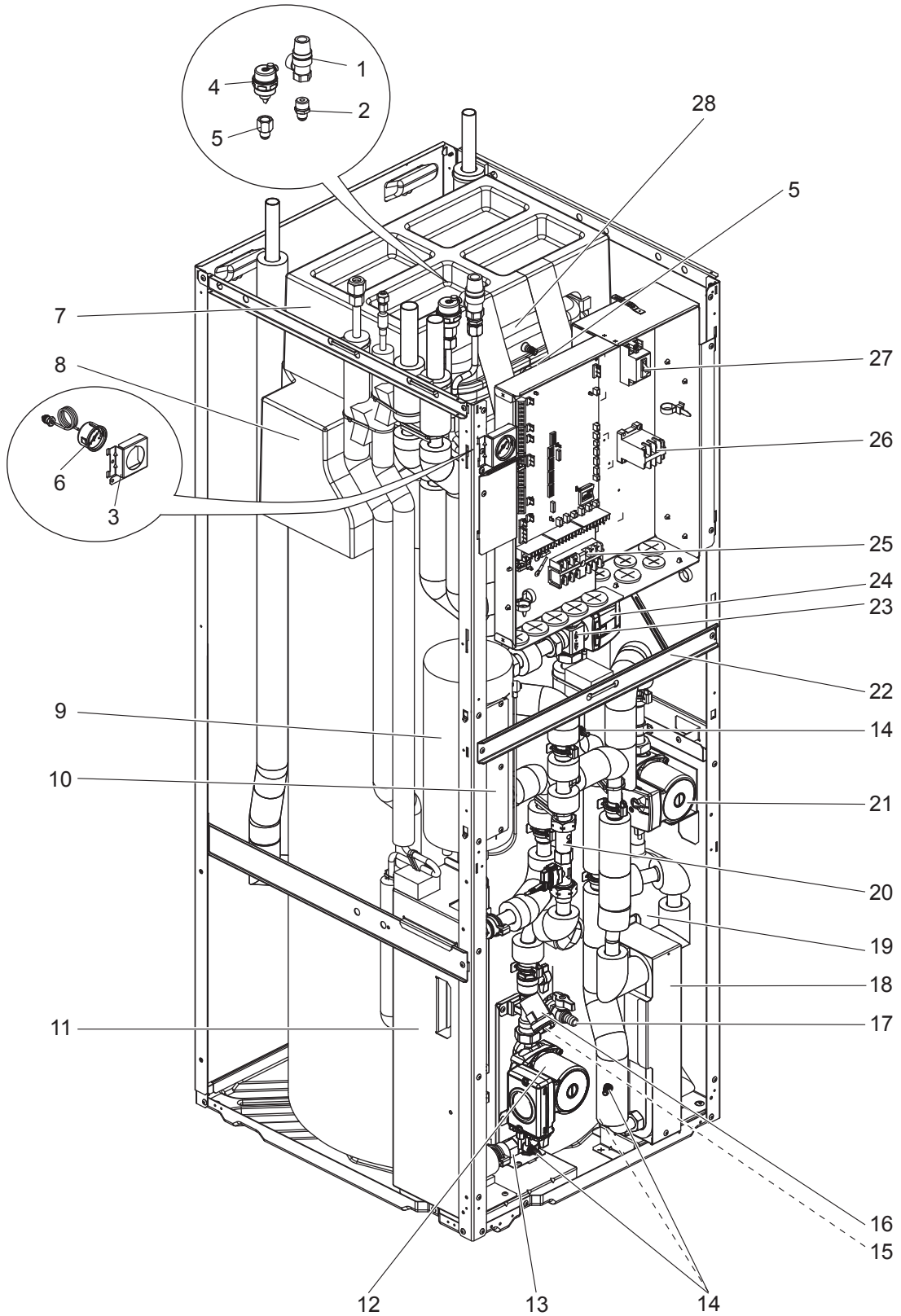

RoHS PARTS LIST

No.	RoHS	Parts No.	Parts name	Specification	Q'ty/unit	Remarks	Wiring diagram symbol	Required regular replacement (*: Required regular inspection)
					EHST20D-MHCW(R1).UK			
1	G	S70 C21 404	PRESSURE RELIEF VALVE	3bar	1			6 years
2	G	S70 C60 096	FLARE JOINT	3/8F-R1/2	1			
3	G	S70 C50 206	MANOMETER STAY		1			
4	G	S70 C17 150	AIR VENT (AUTOMATIC)		1			6 years
5	G	S70 C50 096	FLARE JOINT	3/8F-G3/8	2			
6	G	S70 C20 205	MANOMETER		1			6 years
7	G	—	EXPANSION VESSEL CUSHION ASSY		1	BK00T056G02		
8	G	—	TANK CUSHION TOP ASSY		1	BK00T055G03		
9	G	S70 C15 441	BOOSTER HEATER	0 kW	1			
10	G	—	HEATER STAY		1	BK00R873G02		
11	G	S70 C60 408	WATER COIL ASSY (2HP)	MWA1	1	REFRIGERANT-WATER		
12	G	S70 C06 355	WATER PUMP		1	FOR PRIMARY CIRCUIT	MP1	20,000hrs (3 years)(*)
13	G	S70 C20 356	PUMP VALVE		1			
14	G	S70 C10 358	DRAIN COCK/AIR VENT (WATER CAP ASSY 320)		4	FOR PRIMARY/SANITARY CIRCUIT		6 years
15	G	S70 C28 460	STRAINER PACKING		1	FOR STRAINER		
16	G	S70 C20 452	STRAINER VALVE		1			
17	G	S70 C15 357	DRAIN COCK		1	FOR TANK		
18	G	S70 C80 408	WATER COIL ASSY (W)	CB18-24H	1	WATER-WATER		
19	G	S70 C50 357	SCALE TRAP		1			
20	G	S70 C44 266	FLOW SENSOR (BODY & CABLE)		1			
21	G	S70 C05 355	WATER PUMP		1	FOR SANITARY CIRCUIT	MP4	
22	G	—	DIV FRAME H DWG		1	BK00T057G01		
23	G	S70 C24 406	3WAY VALVE (DIVERTING VALVE)		1			
24	G	S70 C25 762	3WAY VALVE (DIVERTING MOTOR)		1		3WV	
25	G	S70 C20 515	TERMINAL BED	6P	1	(#250LNE+S123)		
26	G	S70 C39 708	CONTACTOR	30A	1		IHC	
27	G	S70 C20 239	EARTH LEAKAGE BREAKER	1 ϕ 20A	1		ECB2	
28	G	S70 C15 402	EXPANSION VESSEL	12L	1			
②9	G	S70 C27 460	O-RING	ORANGE	3	FOR SANITARY SIDE		
③0	G	S70 C23 460	O-RING	BLACK	13			
③1	G	S70 C10 465	FASTENER		14	FOR QUICK CONNECTION		
③2	G	S70 C01 800	GREASE	100 g	14 *	FOR QUICK CONNECTION		

Parts number that is circled is not shown in the figure.

Do not reuse the O-ring or strainer packing that was once removed, but be sure to replace with a new one.

* Apply grease appropriately on the O-ring for the quick connection in the unit.

RoHS PARTS LIST

EHST20D-MHCWR2.UK

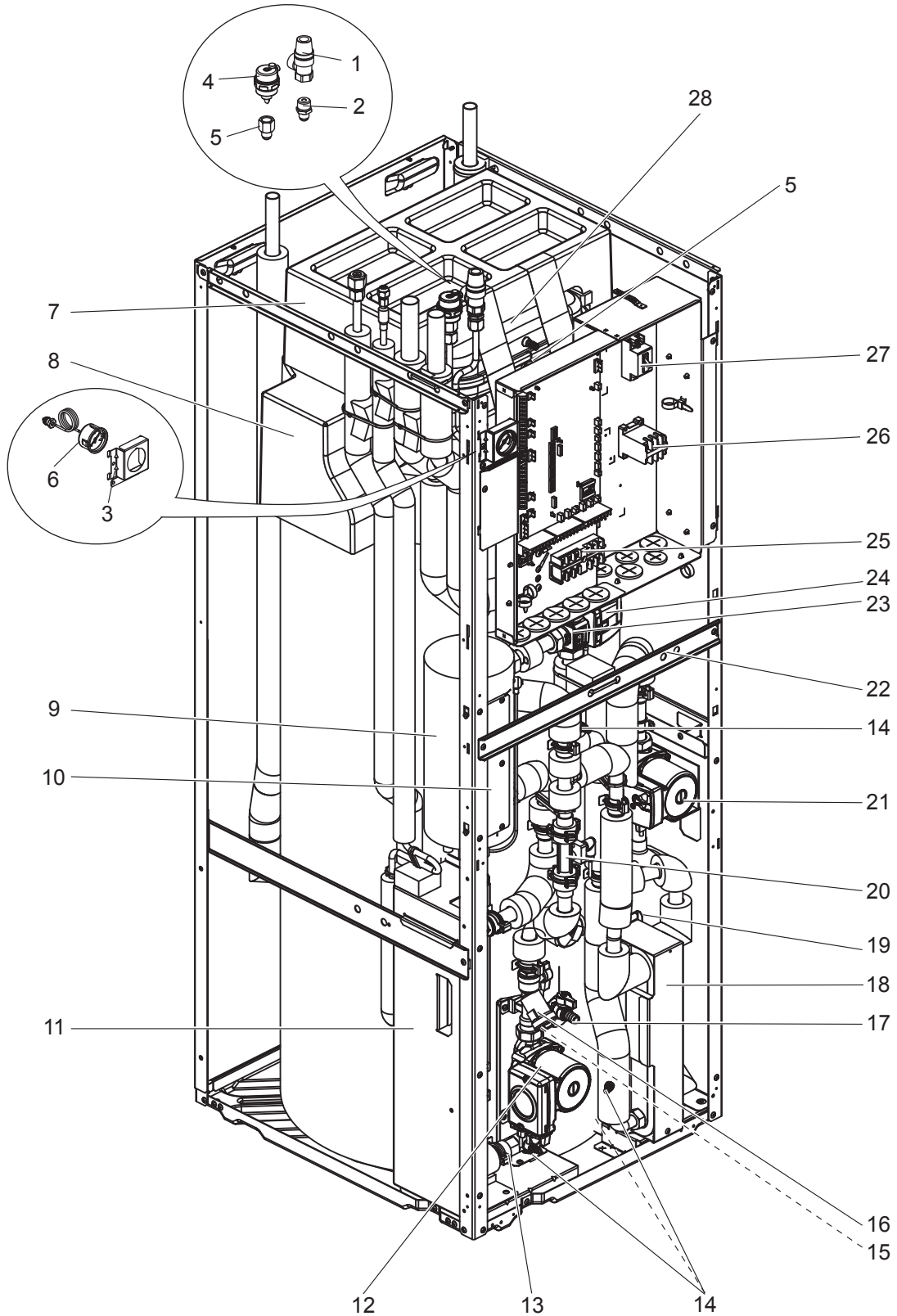

RoHS PARTS LIST

No.	RoHS	Parts No.	Parts name	Specification	Q'ty/unit		Remarks	Wiring diagram symbol	Required regular replacement (*: Required regular inspection)
						EHST20D-MHCWR2.UK			
1	G	S70 C21 404	PRESSURE RELIEF VALVE	3bar		1			6 years
2	G	S70 C60 096	FLARE JOINT	3/8F-R1/2		1			
3	G	S70 C70 206	MANOMETER STAY			1			
4	G	S70 C17 150	AIR VENT (AUTOMATIC)			1			6 years
5	G	S70 C50 096	FLARE JOINT	3/8F-G3/8		2			
6	G	S70 C20 205	MANOMETER			1			6 years
7	G	—	EXPANSION VESSEL CUSHION ASSY			1	BK00T056G02		
8	G	—	TANK CUSHION TOP ASSY			1	BK00T055G03		
9	G	S70 C15 441	BOOSTER HEATER	0 kW		1			
10	G	—	HEATER STAY			1	BK00R873G02		
11	G	S70 C60 408	WATER COIL ASSY (2HP)	MWA1		1	REFRIGERANT-WATER		
12	G	S70 C06 355	WATER PUMP			1	FOR PRIMARY CIRCUIT	MP1	20,000hrs (3 years)(*)
13	G	S70 C20 356	PUMP VALVE			1			
14	G	S70 C10 358	DRAIN COCK/AIR VENT (WATER CAP ASSY 320)			4	FOR PRIMARY/SANITARY CIRCUIT		6 years
15	G	S70 C28 460	STRAINER PACKING			1	FOR STRAINER		
16	G	S70 C20 452	STRAINER VALVE			1			
17	G	S70 C15 357	DRAIN COCK			1	FOR TANK		
18	G	S70 C80 408	WATER COIL ASSY (W)	CB18-24H		1	WATER-WATER		
19	G	S70 C50 357	SCALE TRAP			1			
20	G	S70 C74 266	FLOW SENSOR (BODY & CABLE)			1			
21	G	S70 C05 355	WATER PUMP			1	FOR SANITARY CIRCUIT	MP4	
22	G	—	DIV FRAME H DWG			1	BK02N520G03		
23	G	S70 C24 406	3WAY VALVE (DIVERTING VALVE)			1			
24	G	S70 C25 762	3WAY VALVE (DIVERTING MOTOR)			1		3WV	
25	G	S70 C20 515	TERMINAL BED	6P		1	(#250LNE+S123)		
26	G	S70 C39 708	CONTACTOR	30A		1		IHC	
27	G	S70 C20 239	EARTH LEAKAGE BREAKER	1φ 20A		1		ECB2	
28	G	S70 C15 402	EXPANSION VESSEL	12L		1			
②9	G	S70 C27 460	O-RING	ORANGE		3	FOR SANITARY SIDE		
③0	G	S70 C23 460	O-RING	BLACK		11			
③1	G	S70 C26 460	O-RING	BLACK		2	FOR FLOW SENSOR		
③2	G	S70 C10 465	FASTENER			14	FOR QUICK CONNECTION		
③3	G	S70 C20 465	FASTENER			2	FOR FLOW SENSOR		
③4	G	S70 C01 800	GREASE	100 g		16 *	FOR QUICK CONNECTION		

Parts number that is circled is not shown in the figure.

Do not reuse the O-ring or strainer packing that was once removed, but be sure to replace with a new one.

* Apply grease appropriately on the O-ring for the quick connection in the unit.

RoHS PARTS LIST

EHPT20X-VM2C.UK
 EHPT20X-VM2CR1.UK
 EHPT20X-TM9C.UK
 EHPT20X-TM9CR1.UK

EHPT20X-VM6C.UK
 EHPT20X-VM6CR1.UK

EHPT20X-YM9C.UK
 EHPT20X-YM9CR1.UK

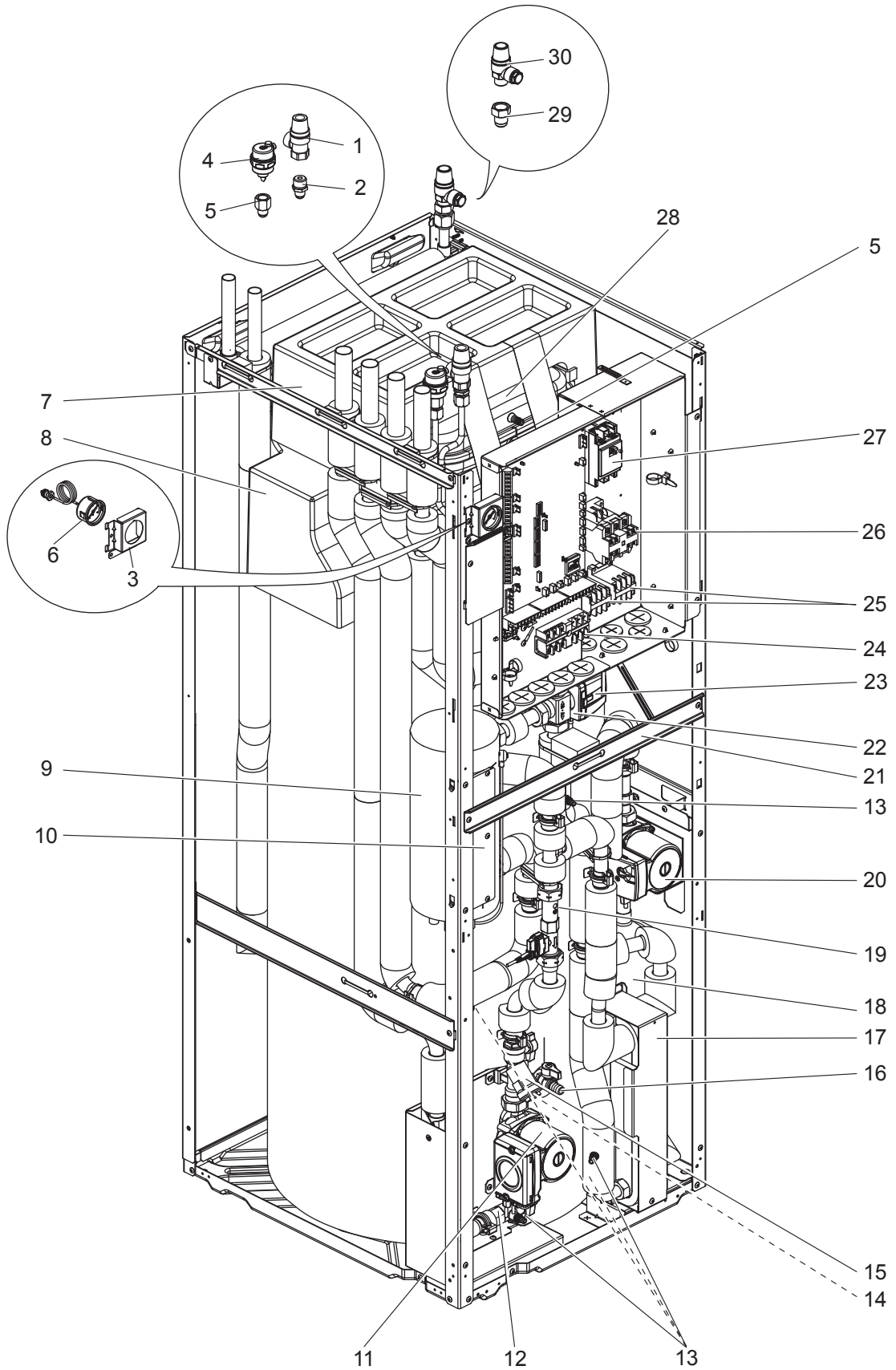

RoHS PARTS LIST

No.	RoHS	Parts No.	Parts name	Specification	Q'ty/unit				Remarks	Wiring diagram symbol	Required regular replacement (*: Required regular inspection)
					EHPT20X-VM2C(R1).UK	EHPT20X-VM6C(R1).UK	EHPT20X-VM9C(R1).UK	EHPT20X-TM9C(R1).UK			
1	G	S70 C21 404	PRESSURE RELIEF VALVE	3bar	1	1	1	1			6 years
2	G	S70 C60 096	FLARE JOINT	3/8F-R1/2	1	1	1	1			
3	G	S70 C50 206	MANOMETER STAY		1	1	1	1			
4	G	S70 C17 150	AIR VENT (AUTOMATIC)		1	1	1	1			6 years
5	G	S70 C50 096	FLARE JOINT	3/8F-G3/8	2	2	2	2			
6	G	S70 C20 205	MANOMETER		1	1	1	1			6 years
7	G	—	EXPANSION VESSEL CUSHION ASSY		1	1	1	1	BK00T056G02		
8	G	—	TANK CUSHION TOP ASSY		1	1	1	1	BK00T055G03		
9	G	S70 C11 441	BOOSTER HEATER	1 ϕ 230V 2 kW	1					BH1	
	G	S70 C12 441	BOOSTER HEATER	1 ϕ 230V 6 kW		1				BH1, BH2	
	G	S70 C13 441	BOOSTER HEATER	3 ϕ 400V 9 kW			1			BH1, BH2	
	G	S70 C14 441	BOOSTER HEATER	3 ϕ 230V 9 kW				1		BH1, BH2	
10	G	—	HEATER STAY		1	1	1	1	BK00R873G02		
11	G	S70 C06 355	WATER PUMP		1	1	1	1	FOR PRIMARY CIRCUIT	MP1	20,000hrs (3 years)(*)
12	G	S70 C20 356	PUMP VALVE		1	1	1	1			
13	G	S70 C10 358	DRAIN COCK/AIR VENT (WATER CAP ASSY 320)		5	5	5	5	FOR PRIMARY/SANITARY CIRCUIT		6 years
14	G	S70 C28 460	STRAINER PACKING		1	1	1	1	FOR STRAINER		
15	G	S70 C20 452	STRAINER VALVE		1	1	1	1			
16	G	S70 C15 357	DRAIN COCK		1	1	1	1	FOR TANK		
17	G	S70 C80 408	WATER COIL ASSY (W)	CB18-24H	1	1	1	1	WATER-WATER		
18	G	S70 C50 357	SCALE TRAP		1	1	1	1			
19	G	S70 C44 266	FLOW SENSOR (BODY & CABLE)		1	1	1	1			
20	G	S70 C05 355	WATER PUMP		1	1	1	1	FOR SANITARY CIRCUIT	MP4	
21	G	—	DIV FRAME H DWG		1	1	1	1	BK00T057G01		
22	G	S70 C24 406	3WAY VALVE (DIVERTING VALVE)		1	1	1	1			
23	G	S70 C25 762	3WAY VALVE (DIVERTING MOTOR)		1	1	1	1		3WV	
24	G	S70 C20 515	TERMINAL BED	6P	1	1	1	1	(#250LNE+S123)		
25	G	S70 C39 708	CONTACTOR	30A	1	2	2	2		BHC1, BHC2	
26	G	S70 C39 708	CONTACTOR	30A	1		1			BHCP	
	G	S70 C29 708	CONTACTOR	45A		1		1		BHCP	
27	G	S70 C20 239	EARTH LEAKAGE BREAKER	1 ϕ 20A	1					ECB1	
	G	S70 C60 239	EARTH LEAKAGE BREAKER	1 ϕ 40A		1				ECB1	
	G	S70 C70 239	EARTH LEAKAGE BREAKER	3 ϕ 30A			1	1		ECB1	
28	G	S70 C15 402	EXPANSION VESSEL	12L	1	1	1	1			
29	G	S70 C70 096	FLARE JOINT	5/8F-R1/2	1	1	1	1			
30	G	S70 C30 404	PRESSURE RELIEF VALVE	10bar	1	1	1	1	FOR TANK		
(31)	G	S70 C23 460	O-RING	BLACK	11	11	11	11			
(32)	G	S70 C10 465	FASTENER		9	9	9	9	FOR QUICK CONNECTION		
(33)	G	S70 C01 800	GREASE	100 g	9 *	9 *	9 *	9 *	FOR QUICK CONNECTION		

Parts number that is circled is not shown in the figure.

Do not reuse the O-ring or strainer packing that was once removed, but be sure to replace with a new one.

* Apply grease appropriately on the O-ring for the quick connection in the unit.

RoHS PARTS LIST

EHPT20X-VM2CR2.UK
EHPT20X-TM9CR2.UK

EHPT20X-VM6CR2.UK

EHPT20X-YM9CR2.UK

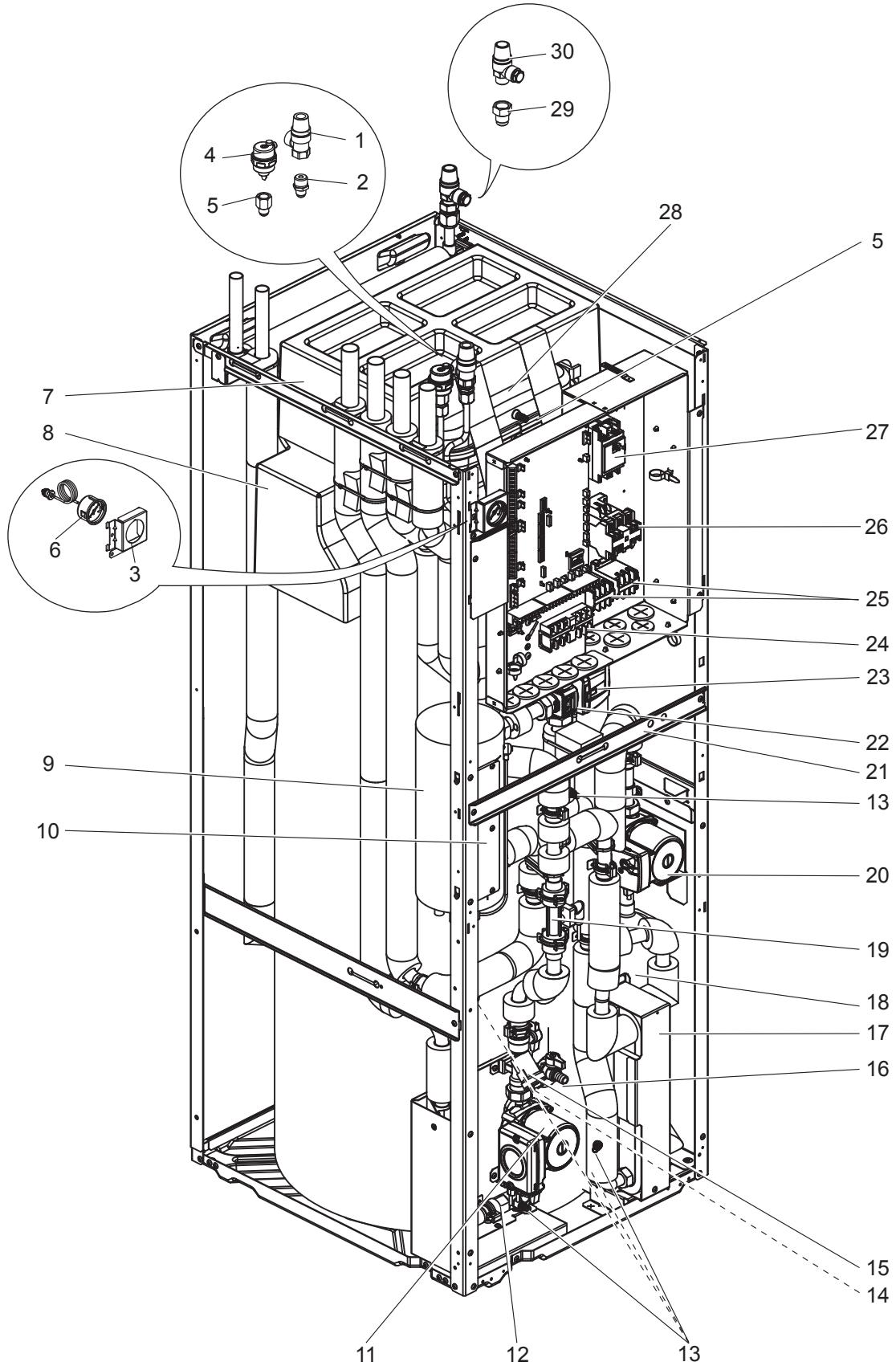

RoHS PARTS LIST

No.	RoHS	Parts No.	Parts name	Specification	Q'ty/unit				Remarks	Wiring diagram symbol	Required regular replacement (*: Required regular inspection)
					EHPT20X-VM2CR2.UK	EHPT20X-VM6CR2.UK	EHPT20X-VM9CR2.UK	EHPT20X-TM9CR2.UK			
1	G	S70 C21 404	PRESSURE RELIEF VALVE	3bar	1	1	1	1			6 years
2	G	S70 C60 096	FLARE JOINT	3/8F-R1/2	1	1	1	1			
3	G	S70 C70 206	MANOMETER STAY		1	1	1	1			
4	G	S70 C17 150	AIR VENT (AUTOMATIC)		1	1	1	1			6 years
5	G	S70 C50 096	FLARE JOINT	3/8F-G3/8	2	2	2	2			
6	G	S70 C20 205	MANOMETER		1	1	1	1			6 years
7	G	—	EXPANSION VESSEL CUSHION ASSY		1	1	1	1	BK00T056G02		
8	G	—	TANK CUSHION TOP ASSY		1	1	1	1	BK00T055G03		
9	G	S70 C11 441	BOOSTER HEATER	1 ϕ 230V 2 kW	1					BH1	
	G	S70 C12 441	BOOSTER HEATER	1 ϕ 230V 6 kW		1				BH1, BH2	
	G	S70 C13 441	BOOSTER HEATER	3 ϕ 400V 9 kW			1			BH1, BH2	
	G	S70 C14 441	BOOSTER HEATER	3 ϕ 230V 9 kW				1		BH1, BH2	
10	G	—	HEATER STAY		1	1	1	1	BK00R873G02		
11	G	S70 C06 355	WATER PUMP		1	1	1	1	FOR PRIMARY CIRCUIT	MP1	20,000hrs (3 years)(*)
12	G	S70 C20 356	PUMP VALVE		1	1	1	1			
13	G	S70 C10 358	DRAIN COCK/AIR VENT (WATER CAP ASSY 320)		5	5	5	5	FOR PRIMARY/SANITARY CIRCUIT		6 years
14	G	S70 C28 460	STRAINER PACKING		1	1	1	1	FOR STRAINER		
15	G	S70 C20 452	STRAINER VALVE		1	1	1	1			
16	G	S70 C15 357	DRAIN COCK		1	1	1	1	FOR TANK		
17	G	S70 C80 408	WATER COIL ASSY (W)	CB18-24H	1	1	1	1	WATER-WATER		
18	G	S70 C50 357	SCALE TRAP		1	1	1	1			
19	G	S70 C74 266	FLOW SENSOR (BODY & CABLE)		1	1	1	1			
20	G	S70 C05 355	WATER PUMP		1	1	1	1	FOR SANITARY CIRCUIT	MP4	
21	G	—	DIV FRAME H DWG		1	1	1	1	BK02N520G03		
22	G	S70 C24 406	3WAY VALVE (DIVERTING VALVE)		1	1	1	1			
23	G	S70 C25 762	3WAY VALVE (DIVERTING MOTOR)		1	1	1	1		3WV	
24	G	S70 C20 515	TERMINAL BED	6P	1	1	1	1	(#250LNE+S123)		
25	G	S70 C39 708	CONTACTOR	30A	1	2	2	2		BHC1, BHC2	
26	G	S70 C39 708	CONTACTOR	30A	1		1			BHCP	
	G	S70 C29 708	CONTACTOR	45A		1		1		BHCP	
27	G	S70 C20 239	EARTH LEAKAGE BREAKER	1 ϕ 20A	1					ECB1	
	G	S70 C60 239	EARTH LEAKAGE BREAKER	1 ϕ 40A		1				ECB1	
	G	S70 C70 239	EARTH LEAKAGE BREAKER	3 ϕ 30A			1	1		ECB1	
28	G	S70 C15 402	EXPANSION VESSEL	12L	1	1	1	1			
29	G	S70 C70 096	FLARE JOINT	5/8F-R1/2	1	1	1	1			
30	G	S70 C30 404	PRESSURE RELIEF VALVE	10bar	1	1	1	1	FOR TANK		
(31)	G	S70 C23 460	O-RING	BLACK	9	9	9	9			
(32)	G	S70 C26 460	O-RING	BLACK	2	2	2	2	FOR FLOW SENSOR		
(33)	G	S70 C10 465	FASTENER		9	9	9	9	FOR QUICK CONNECTION		
(34)	G	S70 C20 465	FASTENER		2	2	2	2	FOR FLOW SENSOR		
(35)	G	S70 C01 800	GREASE	100 g	11 *	11 *	11 *	11 *	FOR QUICK CONNECTION		

Parts number that is circled is not shown in the figure.

Do not reuse the O-ring or strainer packing that was once removed, but be sure to replace with a new one.

* Apply grease appropriately on the O-ring for the quick connection in the unit.

RoHS PARTS LIST

EHPT20X-MHCW.UK
EHPT20X-MHCWR1.UK

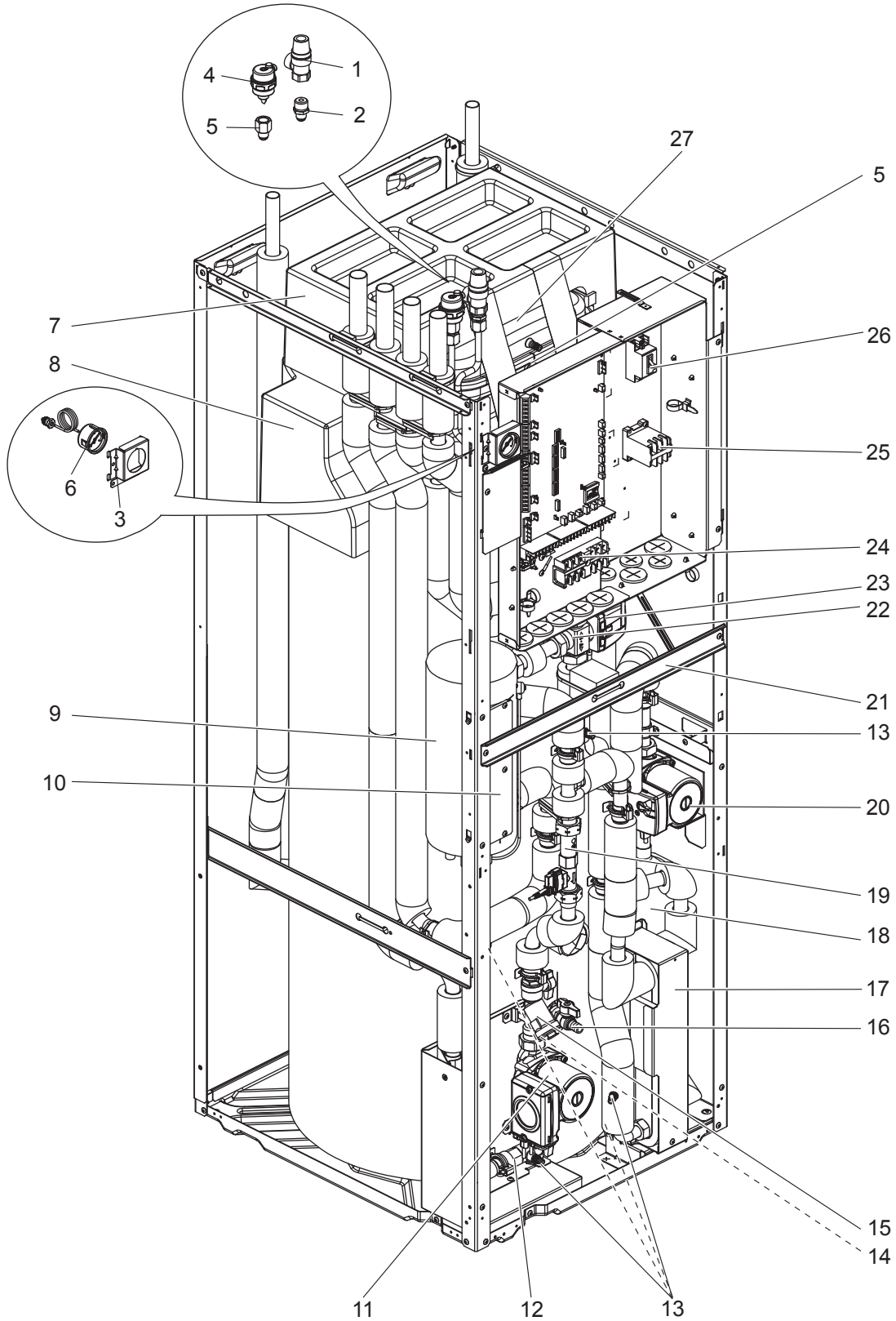

RoHS PARTS LIST

No.	RoHS	Parts No.	Parts name	Specification	Q'ty/unit	Remarks	Wiring diagram symbol	Required regular replacement (*: Required regular inspection)
					EHPT20X-MHCW(R1).UK			
1	G	S70 C21 404	PRESSURE RELIEF VALVE	3bar	1			6 years
2	G	S70 C60 096	FLARE JOINT	3/8F-R1/2	1			
3	G	S70 C50 206	MANOMETER STAY		1			
4	G	S70 C17 150	AIR VENT (AUTOMATIC)		1			6 years
5	G	S70 C50 096	FLARE JOINT	3/8F-G3/8	2			
6	G	S70 C20 205	MANOMETER		1			6 years
7	G	—	EXPANSION VESSEL CUSHION ASSY		1	BK00T056G02		
8	G	—	TANK CUSHION TOP ASSY		1	BK00T055G03		
9	G	S70 C15 441	BOOSTER HEATER	0 kW	1			
10	G	—	HEATER STAY		1	BK00R873G02		
11	G	S70 C06 355	WATER PUMP		1	FOR PRIMARY CIRCUIT	MP1	20,000hrs (3 years)(*)
12	G	S70 C20 356	PUMP VALVE		1			
13	G	S70 C10 358	DRAIN COCK/AIR VENT (WATER CAP ASSY 320)		5	FOR PRIMARY/ SANITARY CIRCUIT		6 years
14	G	S70 C28 460	STRAINER PACKING		1	FOR STRAINER		
15	G	S70 C20 452	STRAINER VALVE		1			
16	G	S70 C15 357	DRAIN COCK		1	FOR TANK		
17	G	S70 C80 408	WATER COIL ASSY (W)	CB18-24H	1	WATER-WATER		
18	G	S70 C50 357	SCALE TRAP		1			
19	G	S70 C44 266	FLOW SENSOR (BODY & CABLE)		1			
20	G	S70 C05 355	WATER PUMP		1	FOR SANITARY CIRCUIT	MP4	
21	G	—	DIV FRAME H DWG		1	BK00T057G01		
22	G	S70 C24 406	3WAY VALVE (DIVERTING VALVE)		1			
23	G	S70 C25 762	3WAY VALVE (DIVERTING MOTOR)		1		3WV	
24	G	S70 C20 515	TERMINAL BED	6P	1	(#250LNE+S123)		
25	G	S70 C39 708	CONTACTOR	30A	1		IHC	
26	G	S70 C20 239	EARTH LEAKAGE BREAKER	1 ϕ 20A	1		ECB2	
27	G	S70 C15 402	EXPANSION VESSEL	12L	1			
28	G	S70 C27 460	O-RING	ORANGE	3	FOR SANITARY SIDE		
29	G	S70 C23 460	O-RING	BLACK	9			
30	G	S70 C10 465	FASTENER		10	FOR QUICK CONNECTION		
31	G	S70 C01 800	GREASE	100 g	10 *	FOR QUICK CONNECTION		

Parts number that is circled is not shown in the figure.

Do not reuse the O-ring or strainer packing that was once removed, but be sure to replace with a new one.

* Apply grease appropriately on the O-ring for the quick connection in the unit.

RoHS PARTS LIST

EHPT20X-MHCWR2.UK

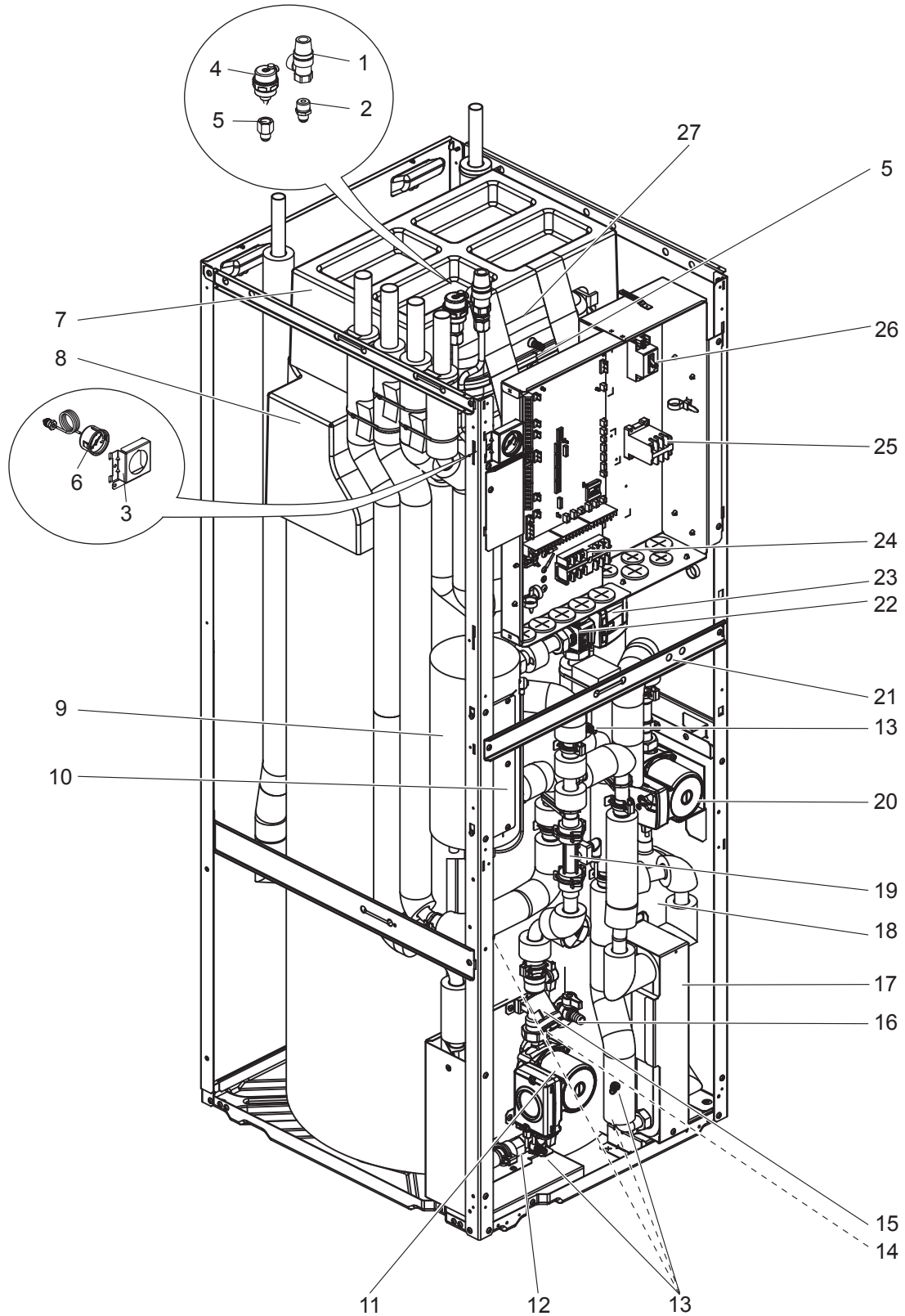

RoHS PARTS LIST

No.	RoHS	Parts No.	Parts name	Specification	Q'ty/unit	Remarks	Wiring diagram symbol	Required regular replacement (*: Required regular inspection)
					EHPT20X-MHCWR2.UK			
1	G	S70 C21 404	PRESSURE RELIEF VALVE	3bar	1			6 years
2	G	S70 C60 096	FLARE JOINT	3/8F-R1/2	1			
3	G	S70 C70 206	MANOMETER STAY		1			
4	G	S70 C17 150	AIR VENT (AUTOMATIC)		1			6 years
5	G	S70 C50 096	FLARE JOINT	3/8F-G3/8	2			
6	G	S70 C20 205	MANOMETER		1			6 years
7	G	—	EXPANSION VESSEL CUSHION ASSY		1	BK00T056G02		
8	G	—	TANK CUSHION TOP ASSY		1	BK00T055G03		
9	G	S70 C15 441	BOOSTER HEATER	0 kW	1			
10	G	—	HEATER STAY		1	BK00R873G02		
11	G	S70 C06 355	WATER PUMP		1	FOR PRIMARY CIRCUIT	MP1	20,000hrs (3 years)(*)
12	G	S70 C20 356	PUMP VALVE		1			
13	G	S70 C10 358	DRAIN COCK/AIR VENT (WATER CAP ASSY 320)		5	FOR PRIMARY/ SANITARY CIRCUIT		6 years
14	G	S70 C28 460	STRAINER PACKING		1	FOR STRAINER		
15	G	S70 C20 452	STRAINER VALVE		1			
16	G	S70 C15 357	DRAIN COCK		1	FOR TANK		
17	G	S70 C80 408	WATER COIL ASSY (W)	CB18-24H	1	WATER-WATER		
18	G	S70 C50 357	SCALE TRAP		1			
19	G	S70 C74 266	FLOW SENSOR (BODY & CABLE)		1			
20	G	S70 C05 355	WATER PUMP		1	FOR SANITARY CIRCUIT	MP4	
21	G	—	DIV FRAME H DWG		1	BK02N520G03		
22	G	S70 C24 406	3WAY VALVE (DIVERTING VALVE)		1			
23	G	S70 C25 762	3WAY VALVE (DIVERTING MOTOR)		1		3WV	
24	G	S70 C20 515	TERMINAL BED	6P	1	(#250LNE+S123)		
25	G	S70 C39 708	CONTACTOR	30A	1		IHC	
26	G	S70 C20 239	EARTH LEAKAGE BREAKER	1φ 20A	1		ECB2	
27	G	S70 C15 402	EXPANSION VESSEL	12L	1			
28	G	S70 C27 460	O-RING	ORANGE	3	FOR SANITARY SIDE		
29	G	S70 C23 460	O-RING	BLACK	7			
30	G	S70 C26 460	O-RING	BLACK	2	FOR FLOW SENSOR		
31	G	S70 C10 465	FASTENER		10	FOR QUICK CONNECTION		
32	G	S70 C20 465	FASTENER		2	FOR FLOW SENSOR		
33	G	S70 C01 800	GREASE	100 g	12*	FOR QUICK CONNECTION		

Parts number that is circled is not shown in the figure.

Do not reuse the O-ring or strainer packing that was once removed, but be sure to replace with a new one.

* Apply grease appropriately on the O-ring for the quick connection in the unit.

RoHS PARTS LIST

EHST20C-VM2C.UK
 EHST20C-VM2CR1.UK
 EHST20C-VM2CR2.UK
 EHST20C-TM9C.UK
 EHST20C-TM9CR1.UK
 EHST20C-TM9CR2.UK
 EHST20C-YM9EC.UK
 EHST20C-YM9ECR1.UK
 EHST20C-YM9ECR2.UK
 EHST20D-VM2C.UK
 EHST20D-VM2CR1.UK
 EHST20D-VM2CR2.UK
 EHST20D-MHCW.UK
 EHST20D-MHCWR1.UK
 EHST20D-MHCWR2.UK
 EHPT20X-VM2C.UK
 EHPT20X-VM2CR1.UK
 EHPT20X-VM2CR2.UK
 EHPT20X-TM9C.UK
 EHPT20X-TM9CR1.UK
 EHPT20X-TM9CR2.UK
 ERST20C-VM2C.UK
 ERST20C-VM2CR1.UK
 ERST20C-VM2CR2.UK
 ERST20D-MEC.UK
 ERST20D-MECR1.UK
 ERST20D-MECR2.UK

EHST20C-VM6C.UK
 EHST20C-VM6CR1.UK
 EHST20C-VM6CR2.UK
 EHST20C-VM2EC.UK
 EHST20C-VM2ECR1.UK
 EHST20C-VM2ECR2.UK
 EHST20C-MHCW.UK
 EHST20C-MHCWR1.UK
 EHST20C-MHCWR2.UK
 EHST20D-VM2EC.UK
 EHST20D-VM2ECR1.UK
 EHST20D-VM2ECR2.UK
 EHST20D-MEC.UK
 EHST20D-MECR1.UK
 EHST20D-MECR2.UK
 EHPT20X-VM6C.UK
 EHPT20X-VM6CR1.UK
 EHPT20X-VM6CR2.UK
 EHPT20X-MHCW.UK
 EHPT20X-MHCWR1.UK
 EHPT20X-MHCWR2.UK
 ERST20C-MEC.UK
 ERST20C-MECR1.UK
 ERST20C-MECR2.UK

EHST20C-YM9C.UK
 EHST20C-YM9CR1.UK
 EHST20C-YM9CR2.UK
 EHST20C-VM6EC.UK
 EHST20C-VM6ECR1.UK
 EHST20C-VM6ECR2.UK
 EHST20C-MEC.UK
 EHST20C-MECR1.UK
 EHST20C-MECR2.UK
 EHST20D-YM9C.UK
 EHST20D-YM9CR1.UK
 EHST20D-YM9CR2.UK
 EHST20D-MHC.UK
 EHST20D-MHCR1.UK
 EHST20D-MHCR2.UK
 EHPT20X-YM9C.UK
 EHPT20X-YM9CR1.UK
 EHPT20X-YM9CR2.UK

ERST20D-VM2C.UK
 ERST20D-VM2CR1.UK
 ERST20D-VM2CR2.UK

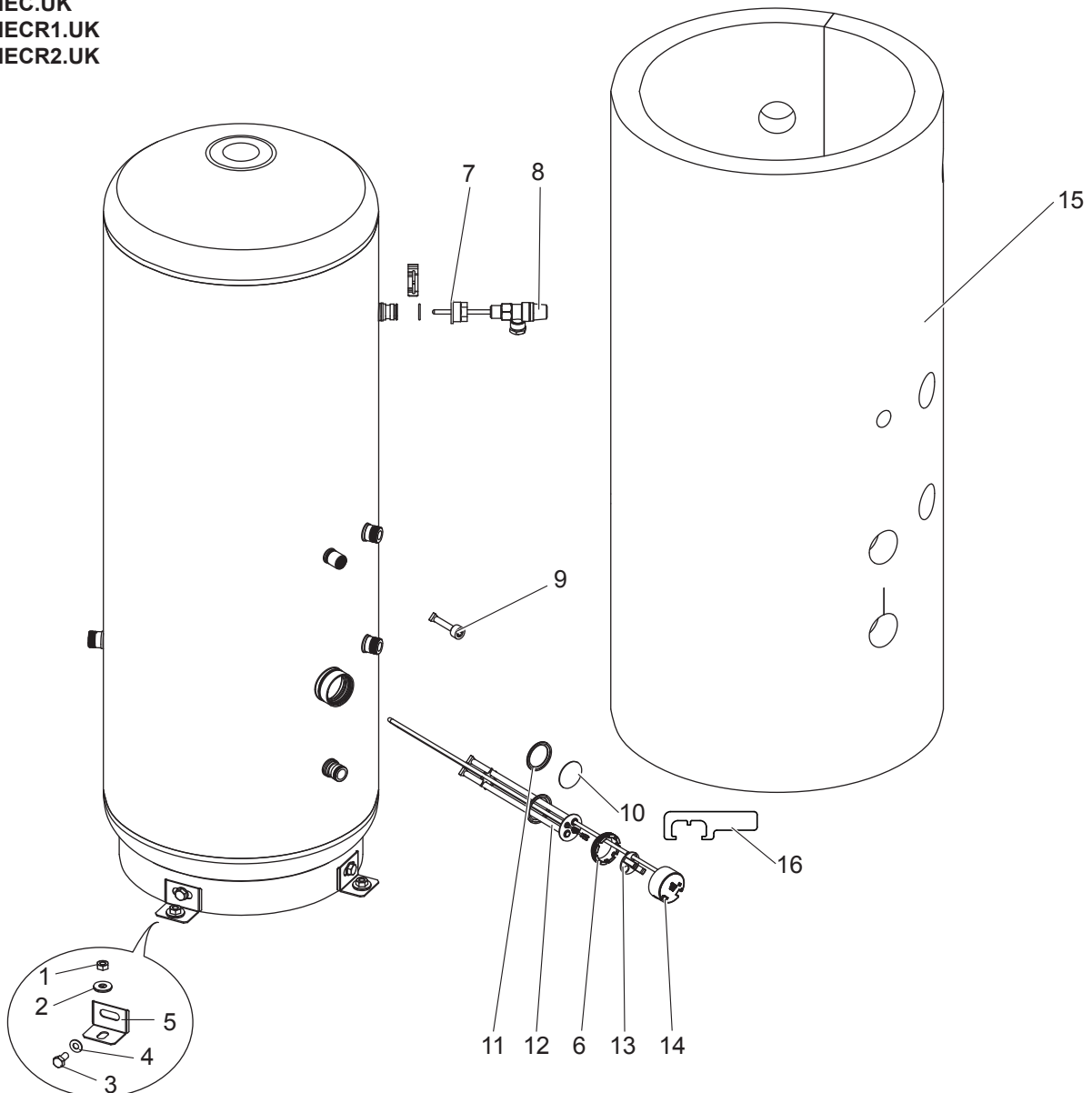

RoHS PARTS LIST

No.	RoHS	Parts No.	Parts name	Specification	Q'ty/unit			Remarks	Wiring diagram symbol	Required regular replacement (-: Required regular inspection)			
					EHST20C-VM2C(R1).UK EHST20C-VM2CR2.UK EHST20C-VM6C(R1).UK EHST20C-VM6CR2.UK EHST20C-YM9C(R1).UK EHST20C-YM9CR2.UK EHST20C-TM9C(R1).UK EHST20C-TM9CR2.UK EHST20C-VM2EC(R1).UK EHST20C-VM2ECR2.UK EHST20C-VM6EC(R1).UK EHST20C-VM6ECR2.UK EHST20C-YM9EC(R1).UK EHST20C-YM9ECR2.UK EHST20C-MEC(R1).UK EHST20C-MECR2.UK EHST20D-MEC(R1).UK EHST20D-MECR2.UK EHST20D-VM2C(R1).UK EHST20D-VM2CR2.UK EHST20D-VM2EC(R1).UK EHST20D-VM2ECR2.UK EHST20D-YM9C(R1).UK EHST20D-YM9CR2.UK EHPT20X-VM2C(R1).UK EHPT20X-VM2CR2.UK EHPT20X-VM6C(R1).UK EHPT20X-VM6CR2.UK EHPT20X-YM9C(R1).UK EHPT20X-YM9CR2.UK EHPT20X-TM9C(R1).UK EHPT20X-TM9CR2.UK ERST20C-VM2C(R1).UK ERST20C-VM2CR2.UK ERST20C-MEC(R1).UK ERST20C-MECR2.UK ERST20D-VM2C(R1).UK ERST20D-VM2CR2.UK ERST20D-MEC(R1).UK ERST20D-MECR2.UK								
1	G	S70 C10 097	NUT	M10	3	3	3						
2	G	S70 C61 097	WASHER		3	3	3						
3	G	S70 C30 097	BOLT	M10×20	3	3	3						
4	G	S70 C20 097	WASHER		3	3	3						
5	G	S70 C30 042	TANK LEG		3	3	3						
6	G	S70 C60 097	BACK NUT		1	1	1						
7	G	S70 C20 405	JOINT (TEMPERATURE AND PRESSURE RELIEF VALVE)			1							
8	G	S70 C19 404	TEMPERATURE AND PRESSURE RELIEF VALVE	90°C/ 7 bar		1							
9	G	S70 C11 525	STAT POCKET ASSEMBLY		1	1	1						
10	G	S70 C40 446	BLANKING PLATE		1			FOR TANK					
11	G	S70 C33 460	ELEMENT PLATE GASKET		1	1	1						
12	G	S70 C50 445	IMMERSION HEATER	1φ 3kW		1	1		IH	2 years(*)			
13	G	S70 C33 461	ELEMENT PLATE TERMINAL COVER			1	1						
14	G	S70 C08 201	THERMOSTAT			1	1		IHT				
15	G	S70 C50 042	TANK INSLATOR		1	1	1						
16	G	S70 C10 406	JIG (FOR BACK NUT)		1	1	1						

Do not reuse the ELEMENT PLATE GASKET (No.11) that was once removed, but be sure to replace with a new one.

When removing and reinstalling the IMMERSION HEATER (No.12) or BLANKING PLATE (No.10), JIG (for BACK NUT) (No.16) is required.

RoHS PARTS LIST

EHST20C-VM2C.UK
 EHST20C-TM9C.UK
 EHST20C-YM9EC.UK
 EHST20D-VM2C.UK
 EHST20D-MEC.UK
 EHPT20X-VM2C.UK
 EHPT20X-TM9C.UK
 ERST20C-VM2C.UK
 ERST20D-VM2C.UK

EHST20C-VM6C.UK
 EHST20C-VM2EC.UK
 EHST20C-MEC.UK
 EHST20D-VM2EC.UK
 EHST20D-MHC.UK
 EHPT20X-VM6C.UK

ERST20C-MEC.UK
 ERST20D-MEC.UK

EHST20C-YM9C.UK
 EHST20C-VM6EC.UK

EHST20D-YM9C.UK

EHPT20X-YM9C.UK

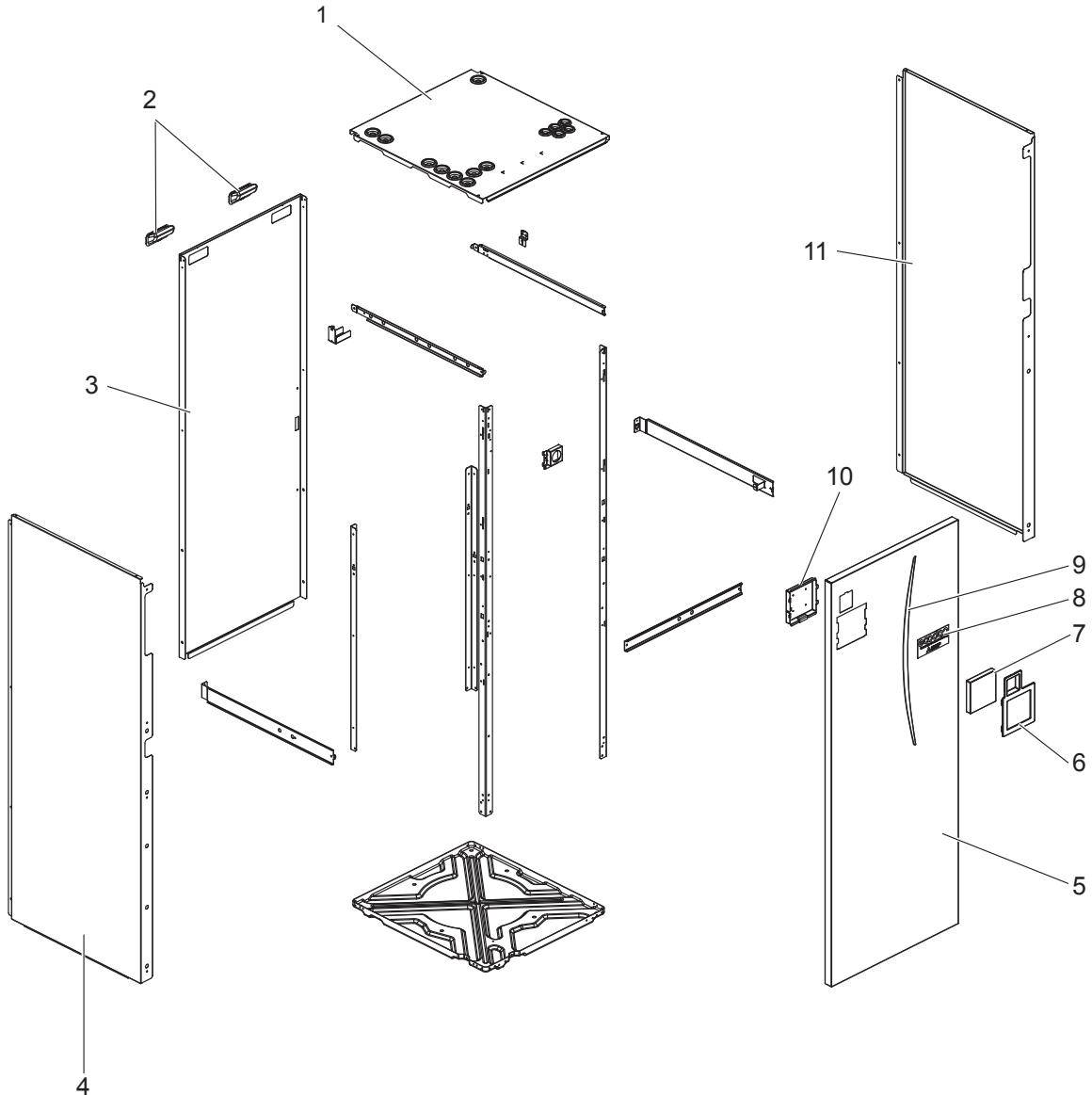

RoHS PARTS LIST

No.	RoHS	Parts No.	Parts name	Specification	Q'ty/unit																Remarks				
					EHST20C-VM2C.UK	EHST20C-VM6C.UK	EHST20C-YM9C.UK	EHST20C-TM9C.UK	EHST20C-VM2EC.UK	EHST20C-VM6EC.UK	EHST20C-YM9EC.UK	EHST20C-MEC.UK	EHST20D-VM2C.UK	EHST20D-VM2EC.UK	EHST20D-YM9C.UK	EHST20D-MEC.UK	EHST20D-MHC.UK	EHPT20X-VM2C.UK	EHPT20X-VM6C.UK	EHPT20X-YM9C.UK		EHPT20X-TM9C.UK	ERST20C-VM2C.UK	ERST20C-MEC.UK	ERST20D-VM2C.UK
1	G	S70 C09 641	TOP PANEL ASSY		1	1	1	1	1	1	1	1	1	1	1	1					1	1	1	1	WITH PIPE LOCATION LABEL & BUSH
	G	S70 C10 641	TOP PANEL ASSY															1	1	1	1				
2	G	S70 30L 655	HANDLE		2	2	2	2	2	2	2	2	2	2	2	2	2	2	2	2	2	2	2	2	
3	G	S70 C19 661	BACK PANEL		1	1	1	1	1	1	1	1	1	1	1	1	1	1	1	1	1	1	1	1	
4	G	S70 C20 662	SIDE PANEL L		1	1	1	1	1	1	1	1	1	1	1	1	1	1	1	1					INSULATION EQUIPPED
	G	S70 C30 662	SIDE PANEL L																		1	1	1	1	
5	G	S70 C21 668	FRONT PANEL		1	1	1	1	1	1	1	1	1	1	1	1	1	1	1	1	1	1	1	1	
6	G	S70 C21 710	MAIN REMOTE CONTROLLER HOLDER		1	1	1	1	1	1	1	1	1	1	1	1	1	1	1	1	1	1	1	1	
7	G	S70 C85 200	MAIN REMOTE CONTROLLER ASSY		1	1	1	1	1	1	1	1	1	1	1	1	1	1	1	1	1	1	1	1	
8	G	S70 C25 699	BRAND LABEL		1	1	1	1	1	1	1	1	1	1	1	1	1	1	1	1	1	1	1	1	
9	G	S70 C30 699	LEAF LABEL		1	1	1	1	1	1	1	1	1	1	1	1	1	1	1	1	1	1	1	1	
10	G	—	MAIN REMOTE CONTROLLER SUPPORT		1	1	1	1	1	1	1	1	1	1	1	1	1	1	1	1	1	1	1	1	BK00R897G01
11	G	S70 C08 662	SIDE PANEL R		1	1	1	1	1	1	1	1	1	1	1	1	1	1	1	1	1	1	1	1	
12	G	S70 C01 699	WIRING DIAGRAM FOR FRONT PANEL	2 kW	1				1				1	1				1			1	1			
	G	S70 C02 699		6 kW		1				1									1						
	G	S70 C03 699		9 kW(Y)			1				1				1						1				
	G	S70 C04 699		9 kW(T)				1													1				
	G	S70 C05 699		0 kW								1						1	1					1	1

Parts number that is circled is not shown in the figure.

RoHS PARTS LIST

EHST20C-VM2CR1.UK
 EHST20C-TM9CR1.UK
 EHST20C-YM9ECR1.UK
 EHST20D-VM2CR1.UK
 EHST20D-MECCR1.UK
 EHPT20X-VM2CR1.UK
 EHPT20X-TM9CR1.UK
 ERST20C-VM2CR1.UK
 ERST20D-VM2CR1.UK

EHST20C-VM6CR1.UK
 EHST20C-VM2ECR1.UK
 EHST20C-MECCR1.UK
 EHST20D-VM2ECR1.UK
 EHST20D-MHCR1.UK
 EHPT20X-VM6CR1.UK

 ERST20C-MECCR1.UK
 ERST20D-MECCR1.UK

EHST20C-YM9CR1.UK
 EHST20C-VM6ECR1.UK

 EHST20D-YM9CR1.UK

 EHPT20X-YM9CR1.UK

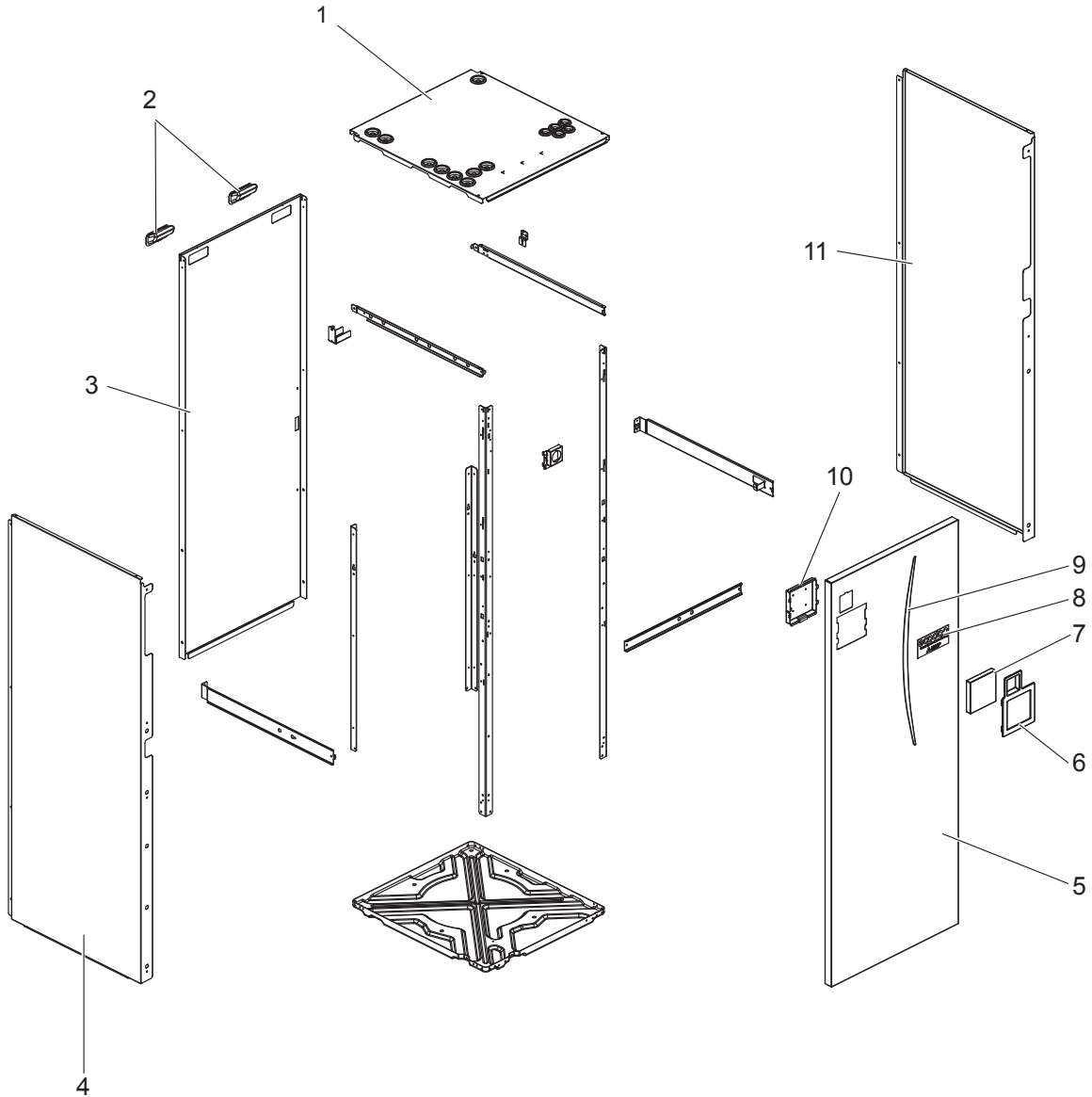

RoHS PARTS LIST

No.	RoHS	Parts No.	Parts name	Specification	Q'ty/unit																Remarks				
					EHST20C-VM2CR1.UK	EHST20C-VM6CR1.UK	EHST20C-YM9CR1.UK	EHST20C-TM9CR1.UK	EHST20C-VM2ECR1.UK	EHST20C-VM6ECR1.UK	EHST20C-YM9ECR1.UK	EHST20C-MECR1.UK	EHST20D-VM2CR1.UK	EHST20D-VM2ECR1.UK	EHST20D-YM9CR1.UK	EHST20D-MECR1.UK	EHST20D-MHCR1.UK	EHPT20X-VM2CR1.UK	EHPT20X-VM6CR1.UK	EHPT20X-YM9CR1.UK		EHPT20X-TM9CR1.UK	ERST20C-VM2CR1.UK	ERST20C-MECR1.UK	ERST20D-VM2CR1.UK
1	G	S70 C09 641	TOP PANEL ASSY		1	1	1	1	1	1	1	1	1	1	1	1					1	1	1	1	WITH PIPE LOCATION LABEL & BUSH
	G	S70 C10 641	TOP PANEL ASSY															1	1	1	1				
2	G	S70 30L 655	HANDLE		2	2	2	2	2	2	2	2	2	2	2	2	2	2	2	2	2	2	2	2	
3	G	S70 C19 661	BACK PANEL		1	1	1	1	1	1	1	1	1	1	1	1	1	1	1	1	1	1	1	1	
4	G	S70 C20 662	SIDE PANEL L		1	1	1	1	1	1	1	1	1	1	1	1	1	1	1	1					INSULATION EQUIPPED
	G	S70 C30 662	SIDE PANEL L																		1	1	1	1	
5	G	S70 C21 668	FRONT PANEL		1	1	1	1	1	1	1	1	1	1	1	1	1	1	1	1	1	1	1	1	
6	G	S70 C21 710	MAIN REMOTE CONTROLLER HOLDER		1	1	1	1	1	1	1	1	1	1	1	1	1	1	1	1	1	1	1	1	
7	G	S70 C85 200	MAIN REMOTE CONTROLLER ASSY		1	1	1	1	1	1	1	1	1	1	1	1	1	1	1	1	1	1	1	1	
8	G	S70 C25 699	BRAND LABEL		1	1	1	1	1	1	1	1	1	1	1	1	1	1	1	1	1	1	1	1	
9	G	S70 C30 699	LEAF LABEL		1	1	1	1	1	1	1	1	1	1	1	1	1	1	1	1	1	1	1	1	
10	G	—	MAIN REMOTE CONTROLLER SUPPORT		1	1	1	1	1	1	1	1	1	1	1	1	1	1	1	1	1	1	1	1	BK00R897G01
11	G	S70 C08 662	SIDE PANEL R		1	1	1	1	1	1	1	1	1	1	1	1	1	1	1	1	1	1	1	1	
12	G	S70 C07 699	WIRING DIAGRAM FOR FRONT PANEL	2 kW	1			1			1	1				1				1	1				
	G	S70 C08 699		6 kW	1			1									1								
	G	S70 C09 699		9 kW(Y)		1			1				1						1						
	G	S70 C10 699		9 kW(T)			1													1					
	G	S70 C11 699		0 kW							1					1	1						1	1	

Parts number that is circled is not shown in the figure.

RoHS PARTS LIST

EHST20C-VM2CR2.UK
 EHST20C-TM9CR2.UK
 EHST20C-YM9ECR2.UK
 EHST20D-VM2CR2.UK
 EHST20D-MECCR2.UK
 EHPT20X-VM2CR2.UK
 EHPT20X-TM9CR2.UK
 ERST20C-VM2CR2.UK
 ERST20D-VM2CR2.UK

EHST20C-VM6CR2.UK
 EHST20C-VM2ECR2.UK
 EHST20C-MECCR2.UK
 EHST20D-VM2ECR2.UK
 EHST20D-MHCR2.UK
 EHPT20X-VM6CR2.UK

 ERST20C-MECCR2.UK
 ERST20D-MECCR2.UK

EHST20C-YM9CR2.UK
 EHST20C-VM6ECR2.UK

 EHST20D-YM9CR2.UK

 EHPT20X-YM9CR2.UK

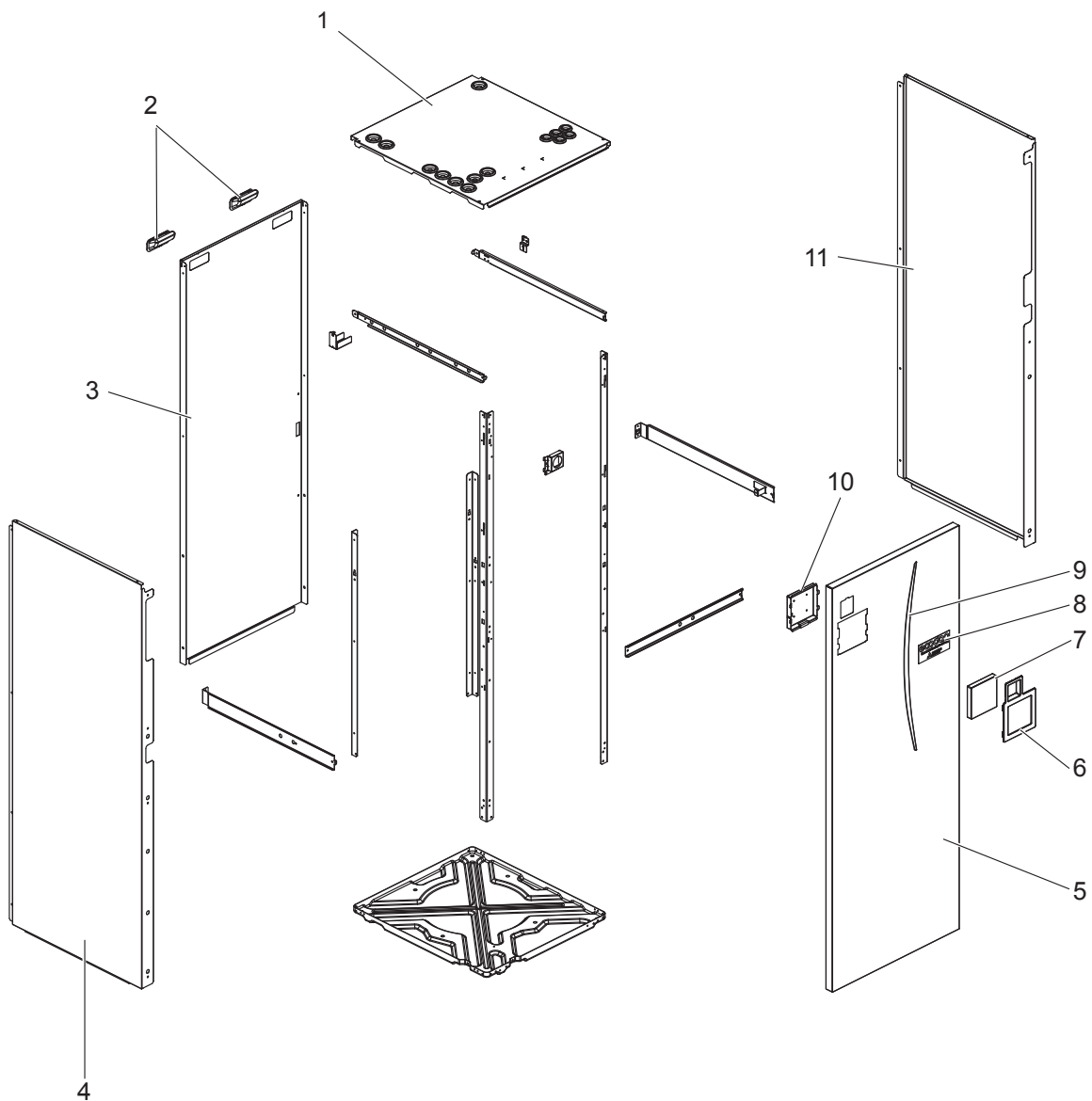

RoHS PARTS LIST

EHST20C-MHCW.UK
EHST20C-MHCWR1.UK
EHST20C-MHCWR2.UK

EHST20D-MHCW.UK
EHST20D-MHCWR1.UK
EHST20D-MHCWR2.UK

EHPT20X-MHCW.UK
EHPT20X-MHCWR1.UK
EHPT20X-MHCWR2.UK

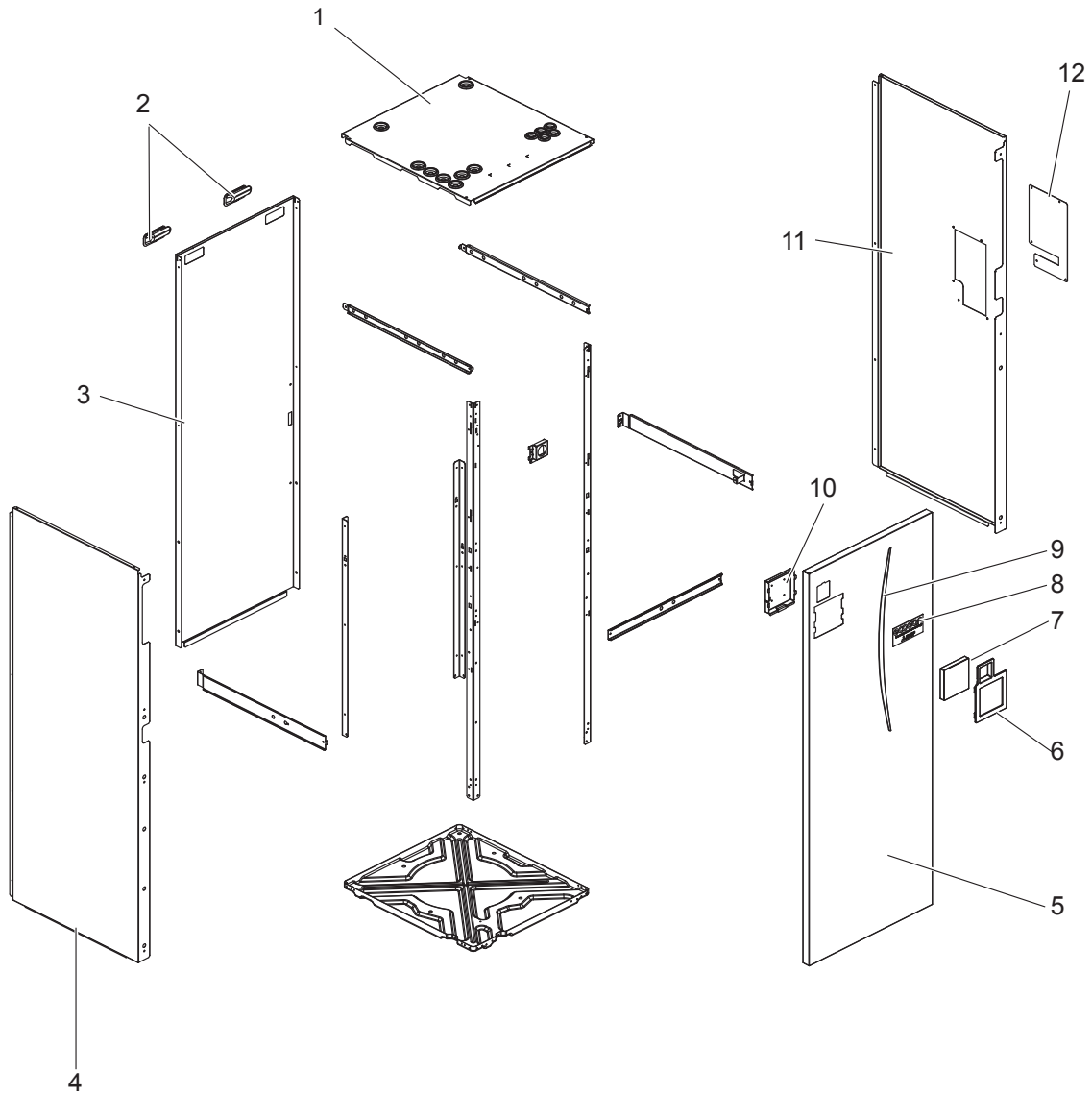

RoHS PARTS LIST

No.	RoHS	Parts No.	Parts name	Specification	Q'ty/unit								Remarks		
					EHST20C-MHCW.UK	EHST20C-MHCWR1.UK	EHST20C-MHCWR2.UK	EHST20D-MHCW.UK	EHST20D-MHCWR1.UK	EHST20D-MHCWR2.UK	EHPT20X-MHCW.UK	EHPT20X-MHCWR1.UK		EHPT20X-MHCWR2.UK	
1	G	S70 C11 641	TOP PANEL ASSY		1	1		1	1						WITH PIPE LOCATION LABEL & BUSH
	G	S70 C12 641	TOP PANEL ASSY								1	1			
	G	S70 C20 641	TOP PANEL ASSY				1			1					
	G	S70 C21 641	TOP PANEL ASSY										1		
2	G	S70 30L 655	HANDLE		2	2	2	2	2	2	2	2	2		
3	G	S70 C19 661	BACK PANEL		1	1	1	1	1	1	1	1	1		
4	G	S70 C20 662	SIDE PANEL L		1	1		1	1		1	1			
	G	S70 C40 662	SIDE PANEL L				1			1			1		
5	G	S70 C21 668	FRONT PANEL		1	1		1	1		1	1			
	G	S70 C22 668	FRONT PANEL				1			1			1		
6	G	S70 C21 710	MAIN REMOTE CONTROLLER HOLDER		1	1		1	1		1	1			
	G	S70 C31 710	MAIN REMOTE CONTROLLER HOLDER				1			1			1		
7	G	S70 C85 200	MAIN REMOTE CONTROLLER ASSY		1	1	1	1	1	1	1	1	1		
8	G	S70 C25 699	BRAND LABEL		1	1	1	1	1	1	1	1	1		
9	G	S70 C30 699	LEAF LABEL		1	1	1	1	1	1	1	1	1		
10	G	—	MAIN REMOTE CONTROLLER SUPPORT		1	1	1	1	1	1	1	1	1	BK00R897G01	
11	G	S70 C09 662	SIDE PANEL R		1	1		1	1		1	1			
	G	S70 C11 662	SIDE PANEL R				1			1			1		
12	G	S70 C30 670	V/M PLATE		1	1		1	1		1	1			
	G	S70 C40 670	V/M PLATE				1			1			1		
13	G	S70 C06 699	WIRING DIAGRAM FOR FRONT PANEL		1			1			1				
	G	S70 C12 699	WIRING DIAGRAM FOR FRONT PANEL			1			1			1			
	G	S70 C18 699	WIRING DIAGRAM FOR FRONT PANEL				1			1			1		

Parts number that is circled is not shown in the figure.

RoHS PARTS LIST

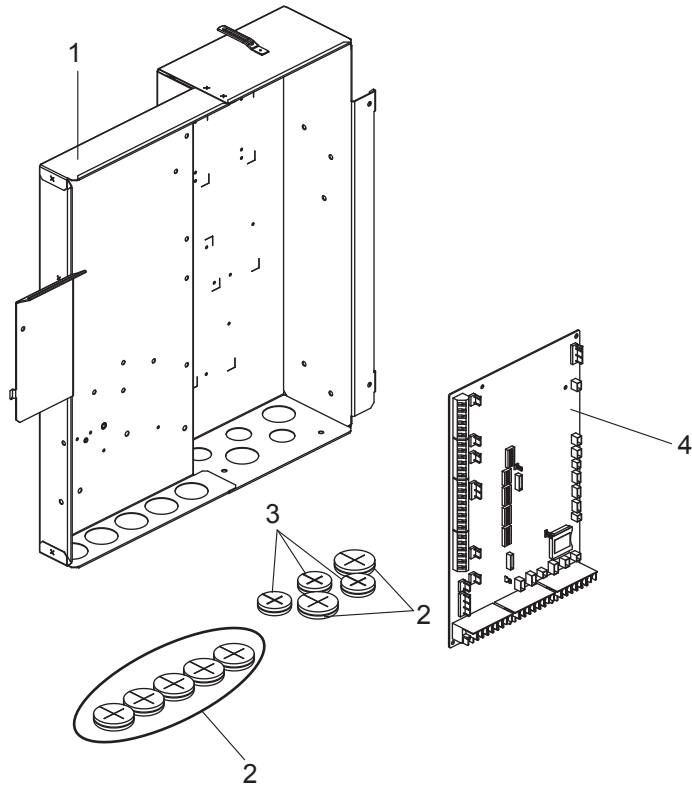

No.	RoHS	Parts No.	Parts name	Q'ty/unit						Remarks	Wiring diagram symbol				
				EHST20D-VM2EC.UK	ERST20C-VM2C.UK	ERST20D-VM2C.UK	EHST20D-VM2ECR1.UK	ERST20C-VM2CR1.UK	ERST20D-VM2CR1.UK			EHST20D-YM9C.UK	EHST20D-YM9CR1.UK	ERST20C-MEC.UK	ERST20D-MEC.UK
1	G	—	CONTROL BOX	1			1						BK00N479G11		
	G	—	CONTROL BOX					1	1					BK00N479G13	
	G	—	CONTROL BOX							1		1		BK00N479G14	
2	G	S70 C21 306	BUSH	12	12	12	12	12	12	12	12	12	FOR CABLE		
3	G	S70 C11 306	BUSH	3	3	3	3	3	3	3	3	3	FOR CABLE		
4	G	S70 C50 315	ATW CONTROLLER	1			1			1				FTC5	
	G	S70 C80 315	ATW CONTROLLER				1		1			1		FTC5	

No.	RoHS	Parts No.	Parts name	Q'ty/unit			Remarks	Wiring diagram symbol
				EHST20D-VM2ECR2.UK	ERST20C-VM2CR2.UK	ERST20D-VM2CR2.UK		
1	G	—	CONTROL BOX	1				BK00N479G16
	G	—	CONTROL BOX				1	BK00N479G18
	G	—	CONTROL BOX				1	BK00N479G19
2	G	S70 C21 306	BUSH	12	12	12	12	FOR CABLE
3	G	S70 C11 306	BUSH	3	3	3	3	FOR CABLE
4	G	S70 C11 315	ATW CONTROLLER	1	1	1	1	FTC5

RoHS PARTS LIST

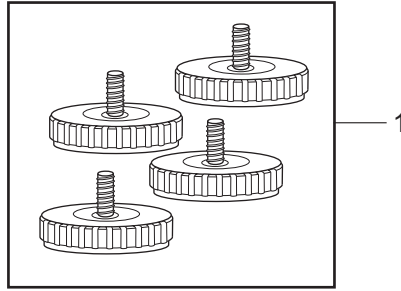

No.	RoHS	Parts No.	Parts name	Specification	Q'ty/unit										Remarks	Wiring diagram symbol		
					EHST20C-VM2C(R1).UK	EHST20C-VM6C(R1).UK	EHST20C-YM9C(R1).UK	EHST20C-TM9C(R1).UK	EHST20C-VM2EC(R1).UK	EHST20C-VM6EC(R1).UK	EHST20C-YM9EC(R1).UK	EHST20C-MHCW(R1).UK	EHST20C-MEC(R1).UK	ERST20C-VM2C(R1).UK			ERST20C-MEC(R1).UK	
1	G	S70 C40 097	ADJUST BOLT		4	4	4	4	4	4	4	4	4	4	4	4	ACCESSORY	
②	G	S70 C15 202	THERMISTOR (TANK WATER TEMP)		1	1	1	1	1	1	1	1	1	1	1	1		THW5
③	G	S70 C25 202	THERMISTOR (FLOW WATER TEMP & RETURN WATER TEMP)		1	1	1	1	1	1	1	1	1	1	1	1		THW1/2
④	G	S70 C35 202	THERMISTOR (LIQUID REFRIGERANT TEMP)		1	1	1	1	1	1	1	1	1	1	1	1		TH2
⑤	G	S70 C55 460	GASKET G1"	G1"	8	8	8	8	8	8	8	6	8	8	8	8	FOR CONNECTION OF WATER CIRCUIT	
⑥	G	S70 C66 460	GASKET G3/4"	G3/4"	8	8	8	8	8	8	8	2	8	8	8	8	FOR CONNECTION OF WATER CIRCUIT	
⑦	G	S70 C77 460	GASKET G3/8"	G3/8"	1	1	1	1					1		1		FOR ONLY EXPANSION VESSEL	
⑧	G	S70 C88 460	GASKET G1/4"	G1/4"	1	1	1	1	1	1	1	1	1	1	1	1	FOR ONLY MANOMETER	
⑨	G	S70 C24 460	PACKING WASHER 1"	1"									2				FOR SANITARY SIDE	
⑩	G	S70 C25 460	PACKING WASHER 3/4"	3/4"									6				FOR SANITARY SIDE	
⑪	G	—	PIPE COVER 19	ID19*OD44* L1200	√	√	√	√	√	√	√	√	√	√	√	√	BH33T353U02 FOR REFRIGERANT (GAS) PIPE	
⑫	G	—	PIPE COVER 25	ID25*OD51* L900	√	√	√	√	√	√	√	√	√	√	√	√	BH33T353H06 FOR WATER PIPE	
⑬	G	—	PIPE COVER 80	ID79.4* OD100*L220	√	√	√	√	√	√	√	√	√	√	√	√	BH33T353U60 FOR SCALE TRAP	
⑭	G	—	PIPE COVER ELBOW		√	√	√	√	√	√	√	√	√	√	√	√	BH33T353L01 FOR ELBOW PIPE BESIDE TANK	

Parts number that is circled is not shown in the figure.

Do not reuse the gaskets (No.5 to 10) that were once removed, but be sure to replace with a new one.

RoHS PARTS LIST

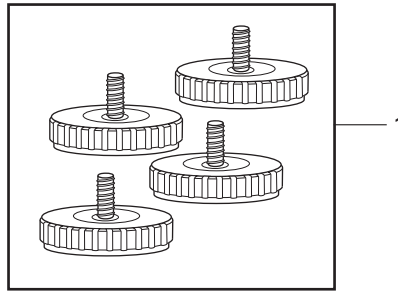

No.	RoHS	Parts No.	Parts name	Specification	Q'ty/unit												Remarks	Wiring diagram symbol	
					EHST20D-VM2C(R1).UK	EHST20D-VM2EC(R1).UK	EHST20D-YM9C(R1).UK	EHST20D-MHCW(R1).UK	EHST20D-MEC(R1).UK	EHST20D-MHC(R1).UK	EHPT20X-VM2C(R1).UK	EHPT20X-VM6C(R1).UK	EHPT20X-YM9C(R1).UK	EHPT20X-TM9C(R1).UK	EHPT20X-MHCW(R1).UK	ERST20D-VM2C(R1).UK			ERST20D-MEC(R1).UK
1	G	S70 C40 097	ADJUST BOLT		4	4	4	4	4	4	4	4	4	4	4	4	4	ACCESSORY	
②	G	S70 C15 202	THERMISTOR (TANK WATER TEMP)		1	1	1	1	1	1	1	1	1	1	1	1		THW5	
③	G	S70 C25 202	THERMISTOR (FLOW WATER TEMP & RETURN WATER TEMP)		1	1	1	1	1	1	1	1	1	1	1	1		THW1/2	
④	G	S70 C35 202	THERMISTOR (LIQUID REFRIGERANT TEMP)		1	1	1	1	1	1					1	1		TH2	
⑤	G	S70 C55 460	GASKET G1"	G1"	8	8	8	6	8	8	8	8	8	8	6	8	8	FOR CONNECTION OF WATER CIRCUIT	
⑥	G	S70 C66 460	GASKET G3/4"	G3/4"	8	8	8	2	8	8	8	8	8	8	2	8	8	FOR CONNECTION OF WATER CIRCUIT	
⑦	G	S70 C77 460	GASKET G3/8"	G3/8"	1		1	1		1	1	1	1	1	1	1	FOR ONLY EXPANSION VESSEL		
⑧	G	S70 C88 460	GASKET G1/4"	G1/4"	1	1	1	1	1	1	1	1	1	1	1	1	FOR ONLY MANOMETER		
⑨	G	S70 C24 460	PACKING WASHER 1"	1"				2							2		FOR SANITARY SIDE		
⑩	G	S70 C25 460	PACKING WASHER 3/4"	3/4"				6							6		FOR SANITARY SIDE		
⑪	G	—	PIPE COVER 10	ID10*OD35* L1050	√	√	√	√	√	√					√	√	BH33T353R11 FOR REFRIGERANT (LIQUID) PIPE		
⑫	G	—	PIPE COVER 13	ID13*OD38* L1020	√	√	√	√	√	√					√	√	BH33T353U50 FOR REFRIGERANT (GAS) PIPE		
⑬	G	—	PIPE COVER 25	ID25*OD51* L900	√	√	√	√	√	√	√	√	√	√	√	√	BH33T353H06 FOR WATER PIPE		
⑭	G	—	PIPE COVER 80	ID79.4* OD100*L220	√	√	√	√	√	√	√	√	√	√	√	√	BH33T353U60 FOR SCALE TRAP		
⑮	G	—	PIPE COVER ELBOW		√	√	√	√	√	√	√	√	√	√	√	√	BH33T353L01 FOR ELBOW PIPE BESIDE TANK		

Parts number that is circled is not shown in the figure.

Do not reuse the gaskets (No.5 to 10) that were once removed, but be sure to replace with a new one.

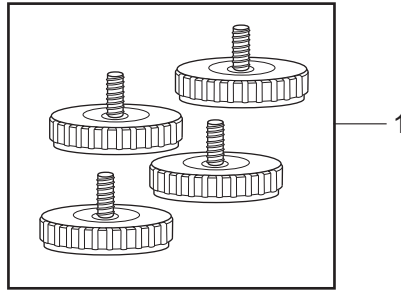

No.	RoHS	Parts No.	Parts name	Specification	Q'ty/unit										Remarks	Wiring diagram symbol	
					EHST20C-VM2CR2.UK	EHST20C-VM6CR2.UK	EHST20C-VM9CR2.UK	EHST20C-TM9CR2.UK	EHST20C-VM2ECR2.UK	EHST20C-VM6ECR2.UK	EHST20C-VM9ECR2.UK	EHST20C-MHCWR2.UK	EHST20C-MECR2.UK	ERST20C-VM2CR2.UK			ERST20C-MECR2.UK
1	G	S70 C40 097	ADJUST BOLT		4	4	4	4	4	4	4	4	4	4	4	ACCESSORY	
②	G	S70 C15 202	THERMISTOR (TANK WATER TEMP)		1	1	1	1	1	1	1	1	1	1	1		THW5
③	G	S70 C25 202	THERMISTOR (FLOW WATER TEMP & RETURN WATER TEMP)		1	1	1	1	1	1	1	1	1	1	1		THW1/2
④	G	S70 C35 202	THERMISTOR (LIQUID REFRIGERANT TEMP)		1	1	1	1	1	1	1	1	1	1	1		TH2
⑤	G	S70 C55 460	GASKET G1"	G1"	8	8	8	8	8	8	8	6	8	8	8	FOR CONNECTION OF WATER CIRCUIT	
⑥	G	S70 C66 460	GASKET G3/4"	G3/4"	8	8	8	8	8	8	8	2	8	8	8	FOR CONNECTION OF WATER CIRCUIT	
⑦	G	S70 C77 460	GASKET G3/8"	G3/8"	1	1	1	1				1	1			FOR ONLY EXPANSION VESSEL	
⑧	G	S70 C88 460	GASKET G1/4"	G1/4"	1	1	1	1	1	1	1	1	1	1	1	FOR ONLY MANOMETER	
⑨	G	S70 C24 460	PACKING WASHER 1"	1"								2				FOR SANITARY SIDE	
⑩	G	S70 C25 460	PACKING WASHER 3/4"	3/4"								6				FOR SANITARY SIDE	
⑪	G	—	PIPE COVER 19	ID19*OD44* L1200	√	√	√	√	√	√	√	√	√	√	√	BH33T353U02 FOR REFRIGERANT (GAS) PIPE	
⑫	G	—	PIPE COVER 25	ID25*OD51* L900	√	√	√	√	√	√	√	√	√	√	√	BH33T353H06 FOR WATER PIPE	
⑬	G	—	PIPE COVER 80	ID79.4* OD100*L220	√	√	√	√	√	√	√	√	√	√	√	BH33T353U60 FOR SCALE TRAP	
⑭	G	—	PIPE COVER ELBOW		√	√	√	√	√	√	√	√	√	√	√	BH33T353L01 FOR ELBOW PIPE BESIDE TANK	

Parts number that is circled is not shown in the figure.

Do not reuse the gaskets (No.5 to 10) that were once removed, but be sure to replace with a new one.

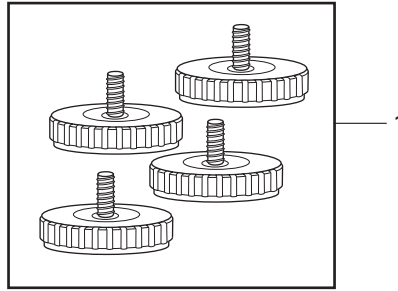

No.	RoHS	Parts No.	Parts name	Specification	Q'ty/unit												Remarks	Wiring diagram symbol	
					EHST20D-VM2CR2.UK	EHST20D-VM2ECR2.UK	EHST20D-YM9CR2.UK	EHST20D-MHCWR2.UK	EHST20D-MECCR2.UK	EHST20D-MHCR2.UK	EHPT20X-VM2CR2.UK	EHPT20X-VM6CR2.UK	EHPT20X-YM9CR2.UK	EHPT20X-TM9CR2.UK	EHPT20X-MHCWR2.UK	ERST20D-VM2CR2.UK			ERST20D-MECCR2.UK
1	G	S70 C40 097	ADJUST BOLT		4	4	4	4	4	4	4	4	4	4	4	4	4	ACCESSORY	
②	G	S70 C15 202	THERMISTOR (TANK WATER TEMP)		1	1	1	1	1	1	1	1	1	1	1	1	1		THW5
③	G	S70 C25 202	THERMISTOR (FLOW WATER TEMP & RETURN WATER TEMP)		1	1	1	1	1	1	1	1	1	1	1	1	1		THW1/2
④	G	S70 C35 202	THERMISTOR (LIQUID REFRIGERANT TEMP)		1	1	1	1	1	1						1	1		TH2
⑤	G	S70 C55 460	GASKET G1"	G1"	8	8	8	6	8	8	8	8	8	8	6	8	8	FOR CONNECTION OF WATER CIRCUIT	
⑥	G	S70 C66 460	GASKET G3/4"	G3/4"	8	8	8	2	8	8	8	8	8	8	2	8	8	FOR CONNECTION OF WATER CIRCUIT	
⑦	G	S70 C77 460	GASKET G3/8"	G3/8"	1		1	1		1	1	1	1	1	1	1		FOR ONLY EXPANSION VESSEL	
⑧	G	S70 C88 460	GASKET G1/4"	G1/4"	1	1	1	1	1	1	1	1	1	1	1	1	1	FOR ONLY MANOMETER	
⑨	G	S70 C24 460	PACKING WASHER 1"	1"				2							2			FOR SANITARY SIDE	
⑩	G	S70 C25 460	PACKING WASHER 3/4"	3/4"				6							6			FOR SANITARY SIDE	
⑪	G	—	PIPE COVER 10	ID10*OD35* L1050	√	√	√	√	√	√						√	√	BH33T353R11 FOR REFRIGERANT (LIQUID) PIPE	
⑫	G	—	PIPE COVER 13	ID13*OD38* L1020	√	√	√	√	√	√						√	√	BH33T353U50 FOR REFRIGERANT (GAS) PIPE	
⑬	G	—	PIPE COVER 25	ID25*OD51* L900	√	√	√	√	√	√	√	√	√	√	√	√	√	BH33T353H06 FOR WATER PIPE	
⑭	G	—	PIPE COVER 80	ID79.4* OD100*L220	√	√	√	√	√	√	√	√	√	√	√	√	√	BH33T353U60 FOR SCALE TRAP	
⑮	G	—	PIPE COVER ELBOW		√	√	√	√	√	√	√	√	√	√	√	√	√	BH33T353L01 FOR ELBOW PIPE BESIDE TANK	

Parts number that is circled is not shown in the figure.

Do not reuse the gaskets (No.5 to 10) that were once removed, but be sure to replace with a new one.

2 OPTIONAL PARTS

2-1. IMMERSION HEATER (1Ph 3kW)

Part No.	PAC-IH03V2-E
----------	--------------

2-2. EHPT ACCESSORIES for UK

Part No.	PAC-WK01UK-E
----------	--------------

* Optional parts for EH*T20*-MHCW

2-3. WIRELESS REMOTE CONTROLLER

Part No.	PAR-WT50R-E
----------	-------------

2-4. WIRELESS RECEIVER

Part No.	PAR-WR51R-E
----------	-------------

2-5. REMOTE SENSOR

Part No.	PAC-SE41TS-E
----------	--------------

2-6. THERMISTOR

Part No.	PAC-TH011-E
----------	-------------

2-7. HIGH TEMPERATURE THERMISTOR

Part No.	PAC-TH011HT-E
----------	---------------

2-8. ecodan Wi-Fi INTERFACE

Part No.	PAC-WF010-E
----------	-------------

2-9. DRAIN PAN STAND

Part No.	PAC-DP01-E
----------	------------

* Optional part for ERST series.

2-10. 2-ZONE KIT

Part No.	PAC-TZ01-E
----------	------------

MITSUBISHI ELECTRIC CORPORATION

HEAD OFFICE: TOKYO BUILDING, 2-7-3, MARUNOUCHI, CHIYODA-KU, TOKYO 100-8310, JAPAN

©Copyright 2014 MITSUBISHI ELECTRIC CORPORATION
Issued: Sep. 2016 No.OCB570 REVISED EDITION-D
Issued: Oct. 2015 No.OCB570 REVISED EDITION-C
Issued: Aug. 2015 No.OCB570 REVISED EDITION-B
Issued: Apr. 2015 No.OCB570 REVISED EDITION-A
Published: Dec. 2014 No.OCB570
Made in Japan

Specifications are subject to change without notice.