

**Air Conditioning Control System  
Centralized Controller  
EB-50GU-A/EB-50GU-J**



**Instruction Book  
–Web Browser for Initial Settings–**

**Contents**

1. Introduction.....	2
1-1. Terms Used in This Manual .....	2
1-2. PC Requirements.....	2
2. Setting the Operating Environment .....	3
2-1. Setting the IP Address of the PC .....	3
2-2. Setting the Web Browser .....	5
3. Logging in to the Web Browser for Initial Settings.....	8
4. Initial Settings .....	11
4-1. Date and Time.....	11
4-2. Basic System .....	12
4-3. Groups .....	20
4-4. Interlocked LOSSNAY .....	23
4-5. Blocks .....	24
5. Functions 1 .....	25
5-1. E-Mail.....	25
5-2. Peak Cut (Energy-save control function) .....	29
5-3. Measurement.....	36
5-4. Energy Management Settings.....	40
6. Functions 2 .....	42
6-1. Set Temperature Range Limit .....	42
6-2. Night Mode (quiet operation) Schedule .....	44
6-3. System-changeover .....	45
7. Functions 3 .....	46
7-1. External Temperature Interlock .....	46
7-2. Night Setback Control .....	48
7-3. Interlock control.....	50
7-4. AHC Port Name Settings .....	58
8. User Settings .....	59
9. Utility.....	61
9-1. Back up/import settings data.....	61
10. License registration for optional functions .....	63

# 1. Introduction

Mitsubishi Electric Corporation's Centralized Controller EB-50GU-A/EB-50GU-J features functions to allow users to monitor and operate the air conditioning units and to make initial settings from a PC over the LAN.

This Instruction Book explains how to make initial settings for the EB-50GU-A/EB-50GU-J using a Web browser.

## 1-1. Terms Used in This Manual

- "Centralized Controller EB-50GU-A/EB-50GU-J" is referred to as "EB-50."
- "Booster unit" and "Water HEX unit" are referred to as "Air To Water (PWFY) unit."
- "Advanced HVAC CONTROLLER" is referred to as "AHC."
- Screen images used in this manual are from Windows 7® and Internet Explorer 9.0.

Note: Windows is a registered trademark or trademark of Microsoft Corporation in the United States and other countries.

## 1-2. PC Requirements

Table 1-1 PC Requirements

Item	Requirement
CPU	1 GHz or faster
Memory	512 MB or more
Screen resolution	1024 x 768 or higher recommended
Browser	Microsoft® Internet Explorer 8.0 Microsoft® Internet Explorer 9.0 * Java execution environment is required. (Oracle® Java Plug-in Ver. 1.7.0_11) * Install Oracle® Java Plug-in that is appropriate for your operating system. When using a 64-bit Internet Explorer, install a 64-bit Java Plug-in. * The version of the Oracle® Java Plug-in can be verified by clicking [Java] in the Control Panel.
On-board LAN port or LAN card	100 BASE-TX
Pointing device	e.g., mouse

Note: Microsoft is a registered trademark or trademark of Microsoft Corporation in the United States and/or other countries.  
Oracle and Java are trademarks or registered trademarks of Oracle Inc. in the United States and/or other countries.

## 2. Setting the Operating Environment

This chapter explains how to make PC settings and Web browser settings to monitor and operate the air conditioning units.

### 2-1. Setting the IP Address of the PC

Follow the instructions below to set the PC's IP address for the Web browser to recognize the EB-50 unit. The PC's IP address must have the same network address as the EB-50's IP address.

(i.e., EB-50's IP address: [192.168.1.1], PC's IP address: [192.168.1.101])

When connecting an EB-50 to an existing LAN, consult the system administrator to decide the IP address of the PC.

Note: When using an EB-50-dedicated LAN, it is recommended that the main EB-50 unit be assigned an IP address between the range [192.168.1.1] and [192.168.1.40] and that the PC connected to the EB-50 be assigned an IP address between the range [192.168.1.101] and [192.168.1.150].

(1) Click [Control Panel] in the Start menu.

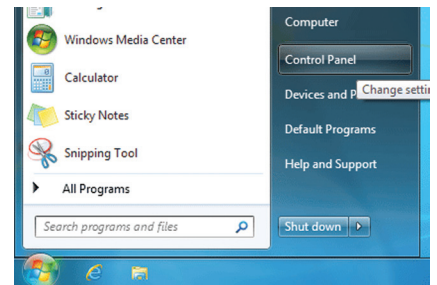

(2) Click [Network and Sharing Center]>[Local Area Setting].  
In the [Local Area Connection Status] window, click [Properties].

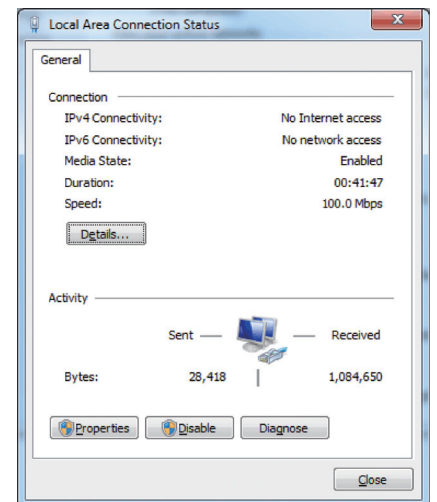

(3) Click [Internet Protocol Version 4 (TCP/IPv4)] to select it, and click [Properties].

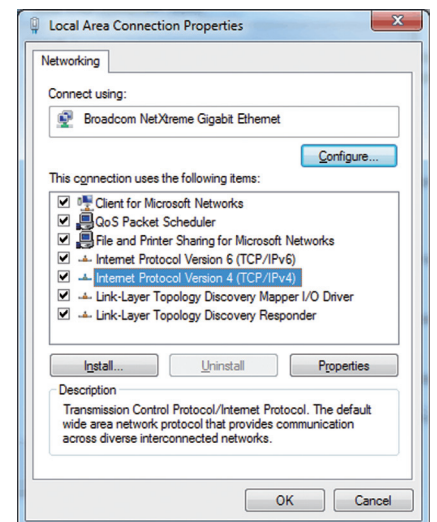

- (4) In the [Internet Protocol Version 4 (TCP/IPv4) Properties] window, check the radio button next to [Use the following IP address]. Enter the PC's IP address (e.g., [192.168.1.101]) in the [IP address] field, and enter the subnet mask [255.255.255.0] (unless otherwise specified) in the [Subnet mask] field. In the [Default gateway] field, enter the gateway address as necessary. (Refer to section 4-2-5 for details.)

Note: Consult the system administrator to decide the IP, subnet mask, and gateway addresses.

- (5) Keep clicking [OK] or [Close] to close all windows.

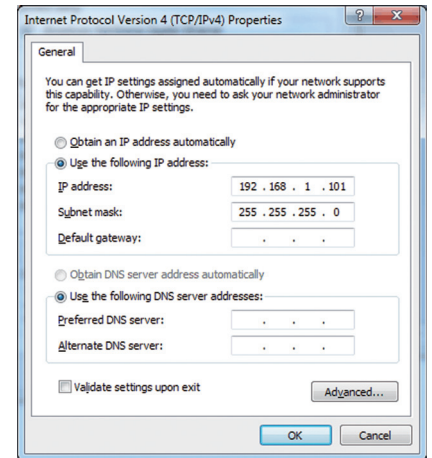



## 2-2. Setting the Web Browser

Web browser setting varies with the Internet connection type. See the sections below for how to make Web browser settings for different types of Internet connection.

**To prevent unauthorized access, always use a security device such as a VPN router when connecting the EB-50 to the Internet.**

### 2-2-1. No Internet connection

To monitor and operate the air conditioning units from a PC with no Internet connection, follow the instructions below to set the environment for the Web browser.

(1) Click [Tools] in the menu bar, then click [Internet options].

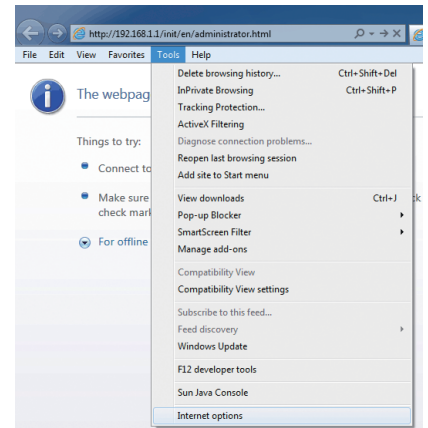

(2) In the [Internet Options] window, click the [Connections] tab.

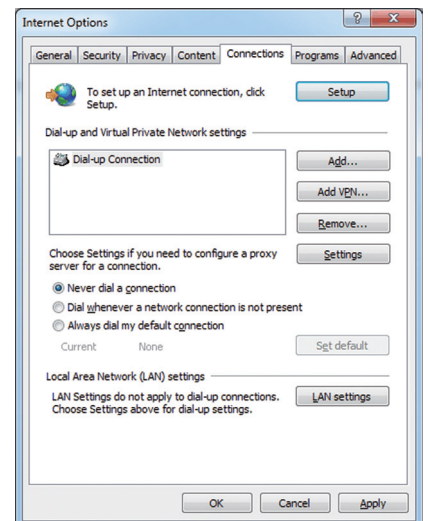

(3) Check the radio button next to [Never dial a connection] in the middle of the window, and click [OK] to close the window.

## 2-2-2. Dial-up Internet connection

To monitor and operate the air conditioning units from a PC that connects to the Internet through a dial-up connection, follow the instructions below to set the environment for the Web browser.

(1) Click [Tools] in the menu bar, then click [Internet options].

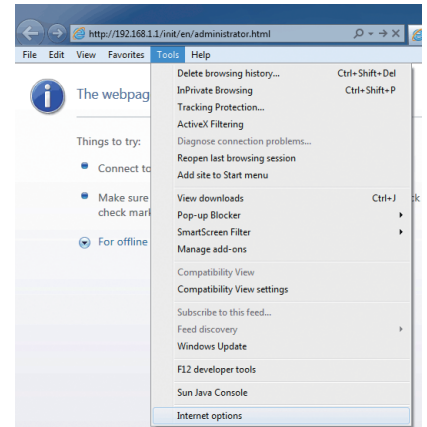

(2) In the [Internet Options] window, click the [Connections] tab.

(3) Check the radio button next to [Dial whenever a network connection is not present] in the middle of the window, and click [OK] to close the window.

By making these settings, a message will appear asking whether or not to use a dial-up connection when an Internet connection is necessary. Follow the message to connect to the Internet.

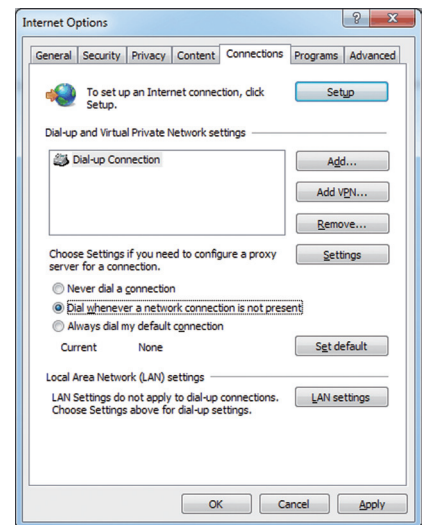

## 2-2-3. Connecting to the Internet via proxy server using an existing LAN

To monitor and operate the air conditioning units from a PC that connects to the Internet through a proxy server by connecting to an existing LAN, such as a LAN within your company, follow the instructions below to set the environment for the Web browser.

(1) Click [Tools] in the menu bar, then click [Internet options].

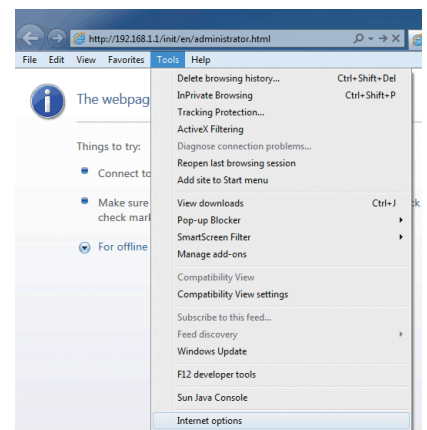

- (2) In the [Internet Options] window, click the [Connections] tab.
- (3) Check the radio button next to [Never dial a connection] in the middle of the window.
- (4) Click [LAN settings] under [Local Area Network (LAN) settings].

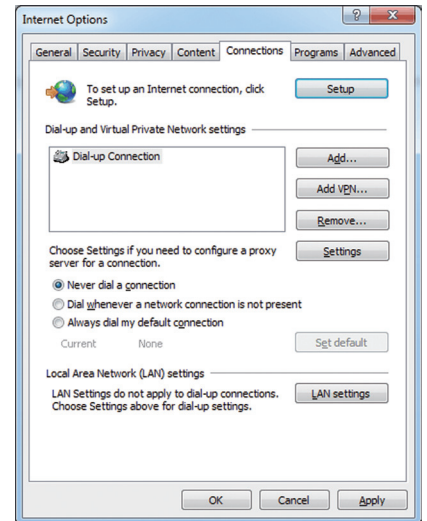

- (5) In the [Local Area Network (LAN) Settings] window, check [Bypass proxy server for local addresses], and click [Advanced].

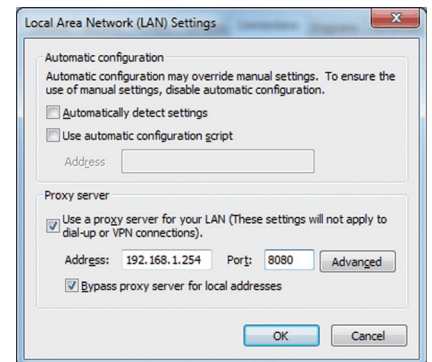

- (6) In the [Proxy Settings] window, enter the EB-50's IP address (e.g., 192.168.1.1) in the [Exceptions] field. Then, keep clicking [OK] or [Close] to close all windows.

If connecting multiple EB-50 units, enter the addresses of all EB-50 units (e.g., [192.168.1.1; 192.168.1.2]). It is also possible to use an asterisk as a wildcard (e.g., [192.168.1.\*]).

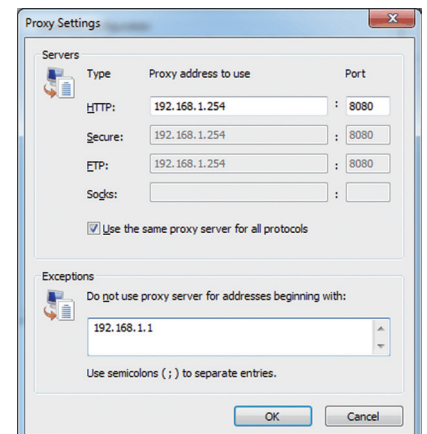

# 3. Logging in to the Web Browser for Initial Settings

- (1) Enter the web page address in the address field of the Web browser as follows:  
**http:// [IP address of the EB-50]/init/administrator.html**  
Press the [Enter] key. A login screen will appear.

Note: If the IP address of the EB-50 is [192.168.1.1], the web page address is [http://192.168.1.1/init/administrator.html].

Note: Default IP address of EB-50 is [192.168.1.1].

Note: If the login screen does not appear then take the steps below to delete the temporary files.

<Internet Explorer>

1. Click [Tools] in the menu bar, then click [Internet options].
2. On the [General] tab, click [Delete] in the middle of the window.
3. In the [Delete Browsing History] window, click [Delete].

<Java>

1. Click [Control Panel] from the Start menu.
2. Click the [Java] icon to launch the Java Control Panel.
3. On the [General] tab, click [Settings] in the [Temporary Internet Files] section.
4. Click [Delete Files].
5. In the [Delete Files and Applications] window, click [OK].

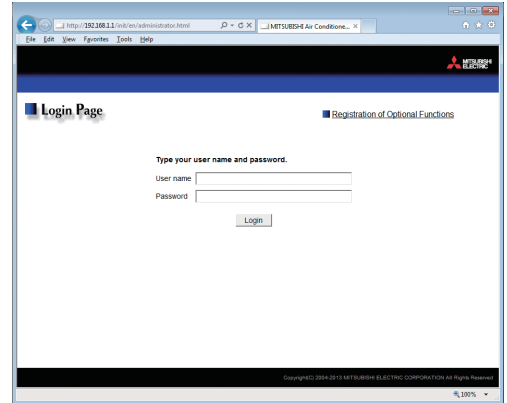

Note: The web page will be displayed in the same language as the operating system on the PC.

The web page can be displayed in other languages by entering the web page address as follows:

Chinese	http://[IP address of the EB-50]/init/ <b>zh</b> /administrator.html
English	http://[IP address of the EB-50]/init/ <b>en</b> /administrator.html
French	http://[IP address of the EB-50]/init/ <b>fr</b> /administrator.html
German	http://[IP address of the EB-50]/init/ <b>de</b> /administrator.html
Italian	http://[IP address of the EB-50]/init/ <b>it</b> /administrator.html
Japanese	http://[IP address of the EB-50]/init/ <b>ja</b> /administrator.html
Portuguese	http://[IP address of the EB-50]/init/ <b>pt</b> /administrator.html
Russian	http://[IP address of the EB-50]/init/ <b>ru</b> /administrator.html
Spanish	http://[IP address of the EB-50]/init/ <b>es</b> /administrator.html

Note: You can add the web page address to your Favorites for easy access in the future.

- (2) Enter the user name and the password in the login screen, and click [Login]. A setting screen will appear. The table below shows the default user names, passwords, and functions that are available for maintenance users and building managers.

User	Default user name	Default password	Available functions	
Maintenance user	initial	init	Initial Settings	Date and Time, Basic System, Groups, Interlocked LOSSNAY, Blocks
			Functions 1	E-Mail, Peak Cut, Measurement, Energy Management Settings
			Functions 2	Set Temperature Range Limit, Night Mode Schedule, System-changeover
			Functions 3	External Temperature Interlock, Night Setback Control, Interlock control, AHC Port Name Settings
			User Settings	User Settings
			Utility	Back up/import settings data
Building manager	administrator	admin	Out of the functions listed above, the items to which access rights have been given on the User Settings screen are available.	

Note: A building manager will use the same user name and password for the Web Browser for System Maintenance Engineer.

Note: A maintenance user can specify the functions to be made available for building managers. Refer to chapter 8 "User Settings" for details.

Note: It is recommended to change the default user name and password so that the users other than the maintenance users and building managers will not be able to change the settings.

# Encrypting the communication data and logging in to the Web browser (HTTPS connection)

EB-50 can encrypt communication data using HTTPS (SSL).

When connecting the EB-50 to the LAN that is accessible to the general public, it is recommended that the following settings be made so that the units are monitored and controlled on the encrypted web page.

Note: Depending on the operating system or the Java version, HTTPS encrypted communication may not be enabled properly. If this happens, use an HTTP connection as explained in the previous page.

- (1) Prefix the web address with [https], enter the rest of the address, and press the [Enter] key.

**https://[IP Address of the EB-50]/init/administrator.html**

Note: If the IP address of the EB-50 is [192.168.1.1], the web page address is [https://192.168.1.1/init/administrator.html].

The encrypted data communication will begin, and the Login screen will appear.

If a security certificate error page appears instead of the Login screen, go to step (2) below.

- (2) If the security certificate is invalid, a security certificate error page (as shown at right) will appear. Click [Continue to this website (not recommended)].

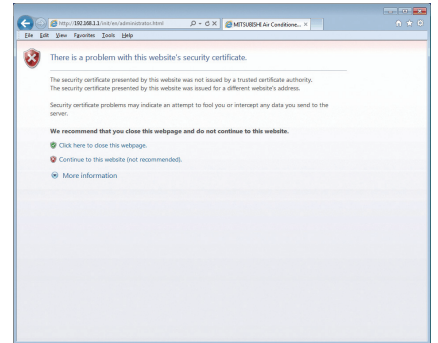
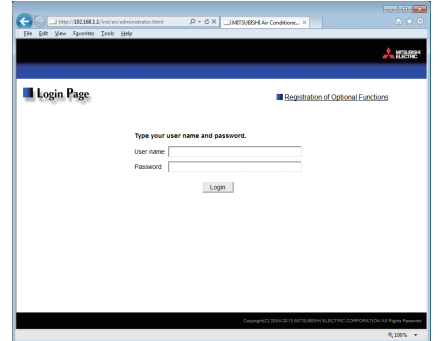

- (3) If the connection is successfully made, the Login screen will appear.

Note: Although the address bar will turn red and a message "Certificate error" will appear, you can still access the Web browser.

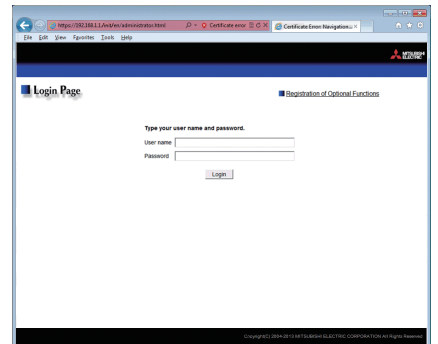
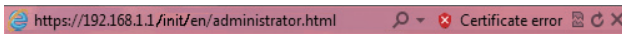

# 4. Initial Settings

This chapter explains how to set the initial settings on the Web Browser for Initial Settings.

## 4-1. Date and Time

Click [Initial Settings] in the menu bar, and then click [Date and Time] to access the date and time settings screen.

Set the current date and time, and then click [Save Settings] to send the settings to the EB-50.

Note: The date and time settings may not be accessible if logged in as a building manager.

Note: The date and time settings made on this screen will be reflected on all the units in the M-NET system.

Note: The date and time cannot be set on this screen if the [Time Master] setting is set to [Sub].

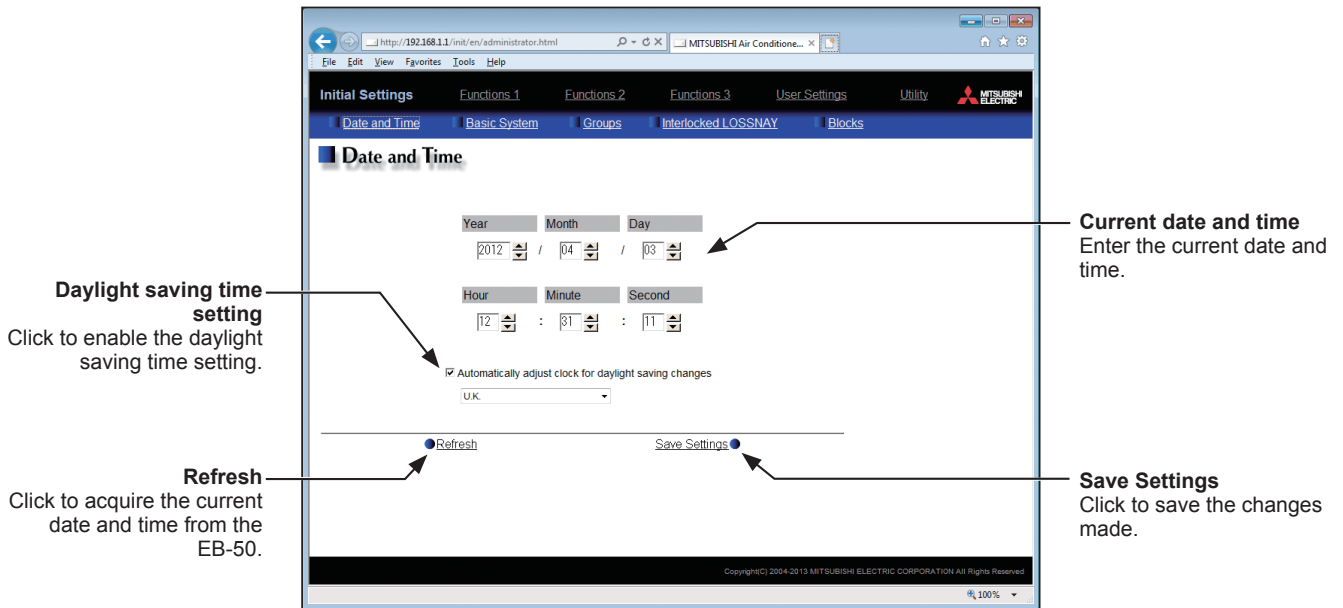

(1) Enter the current date and time.

(2) To adjust the daylight saving time automatically, check the [Automatically adjust clock for daylight saving changes] checkbox, and select the applicable country in the pulldown menu.

If the applicable country is not in the pulldown menu, select [Custom Settings] instead. A [Custom Settings] button will appear on the right of the pulldown menu.

Click the [Custom Settings] button to open the Custom Settings screen, and configure the daylight saving time setting.

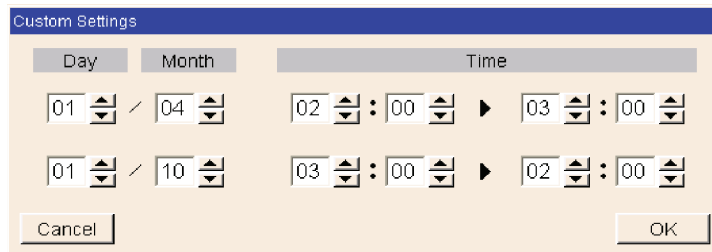

Custom Settings screen

## 4-2. Basic System

Click [Initial Settings] in the menu bar, and then click [Basic System] to access the Basic System settings screen. Make necessary basic system settings such as EB-50 unit settings, network settings, and M-NET settings, and then click [Save Settings] to send the settings to the EB-50. A message will appear asking whether or not to restart the EB-50. Click [OK] to restart the EB-50 to reflect the changes.

Note: The Basic System settings may not be accessible if logged in as a building manager.

**Unit Settings**  
Set the EB-50 name and unit ID.

**Network Settings**  
Set the EB-50 IP address and subnet mask.

**Display Format**  
Set the screen display items for the EB-50 and the Web browser.

**Refresh**  
Click to import the settings from EB-50.

**M-NET Settings**  
Set the EB-50 M-NET address and range of prohibited controllers.

**External Input Setting**  
Set the EB-50 external signal input mode.

**Advanced Setting**  
Click to display the screen for making advanced settings.

**Save Settings**  
Click to send the settings to EB-50.

### 4-2-1. Unit Settings

Follow the instructions below to set the EB-50 unit name and unit ID in the [Unit Settings] section. The EB-50 serial number and software version will appear.

Unit Settings	
Name	<input type="text"/>
Unit ID	<input type="text" value="000001"/> (6 figures)
SERIAL No.	30B12-703
Software Version	7.00(1.00)

- (1) Enter the unit name in the [Name] field in 40 alphanumeric or symbol characters or less. The name entered here will be used on the screen of the software that controls multiple EB-50 units and will also be used as a sender name in the error notification e-mail and e-mail alarm.

Note: The following characters cannot be used in the [Name] field: <, >, &, ", or '.

- (2) Enter the unit ID in the [Unit ID] field in 6 figures. Use this setting to manage the multiple unit IDs. The unit ID entered here will be used on the screen of the software that controls multiple EB-50 units and will also be used as a sender ID in the error notification e-mail and e-mail alarm.



### 4-2-2. M-NET Settings



- (1) Enter [0] in the [M-NET Address] field (unless otherwise specified).
- (2) When the local remote controller operation is prohibited on the Web Browser for System Maintenance Engineer, this setting determines the scope of its applicability. Select [SC/RC] to prohibit the operation from both the sub system controllers and the remote controllers. Select [RC Only] to prohibit the operation only from the remote controllers.

### 4-2-3. External Input Setting

Using the external signal input function, the following types of collective operations can be performed for all connected air conditioning units: Emergency stop, ON/OFF operation, and Prohibit/Permit local remote controller operation.

A separately-sold external input/output adapter (PAC-YG10HA) and external power supply are required. Select the external signal input mode, referring to the explanations below.

Note: General equipments connected via DIDO controller (PAC-YG66DCA) cannot be collectively run or stopped by using the external signal input function unless [Emergency Stop (Level signal)] is selected and relevant switches on the DIDO controller are set.

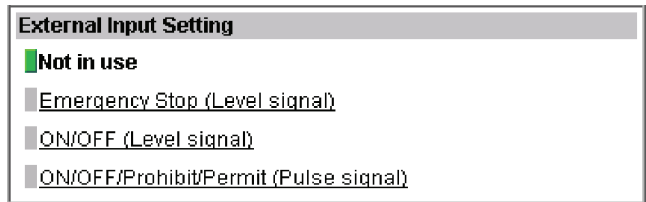

- (1) Select [Not in use] when not using the external signal input function.
- (2) Select [Emergency Stop (Level signal)] when using a level signal to collectively run or stop all the air conditioning units connected to the EB-50 in an emergency. During an emergency stop, the ON/OFF operation from the local remote controllers will be prohibited, and the ON/OFF operation and Prohibit/Permit settings on the EB-50 will be prohibited.

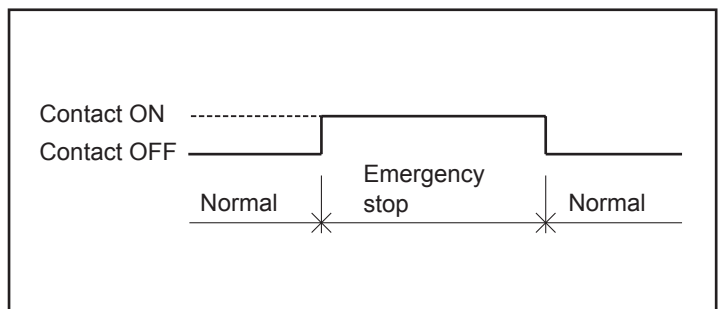
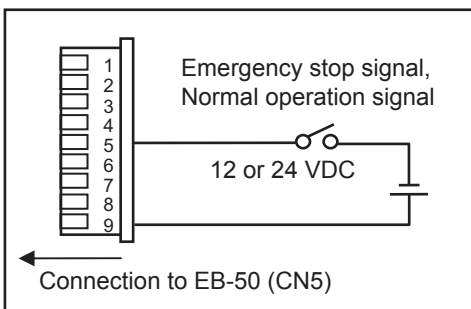

- (3) Select [ON/OFF (Level signal)] when using a level signal to collectively run or stop all the air conditioning units connected to the EB-50. The ON/OFF operation from the local remote controllers will be prohibited, and the ON/OFF operation and Prohibit/Permit settings on the EB-50 will be prohibited.

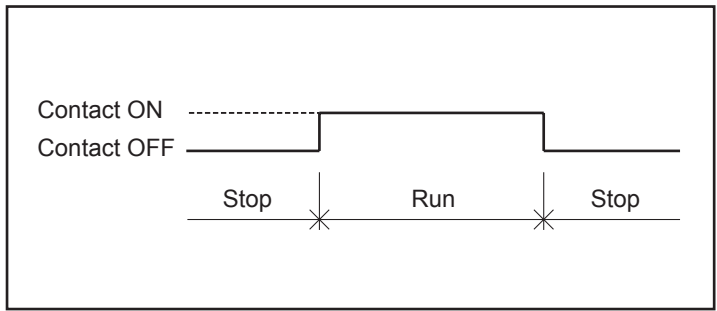
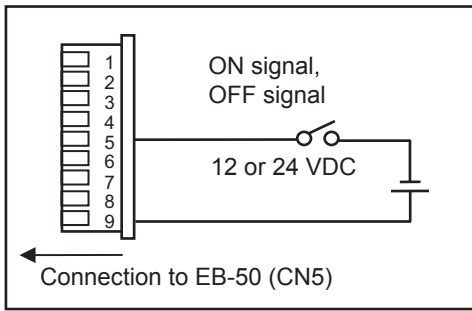

- (4) Select [ON/OFF/Prohibit/Permit (Pulse signal)] when using a pulse signal to collectively run or stop all the air conditioning units connected to the EB-50, or to collectively prohibit or permit the operation from the local remote controllers.

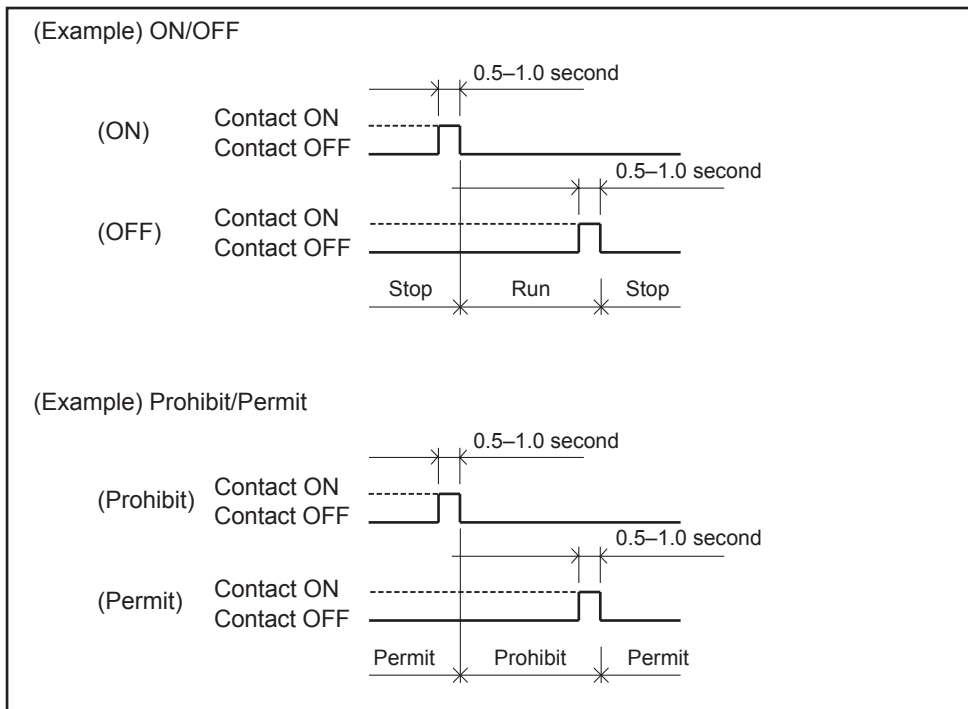
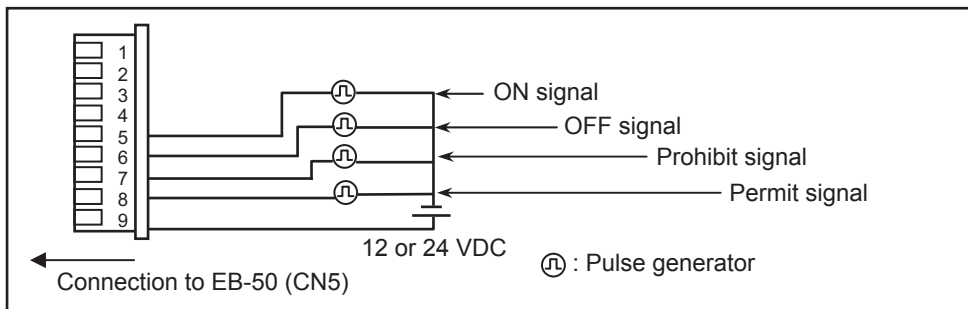

## 4-2-4. Advanced Setting

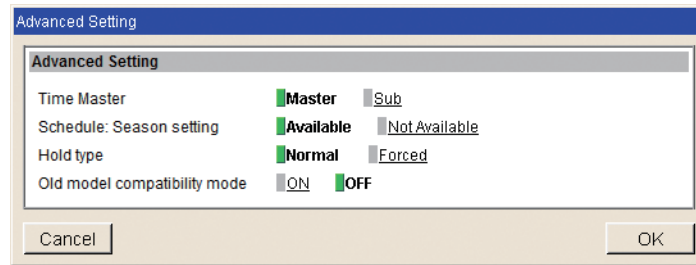

### 4-2-4-1. Time Master/Sub

In the [Time Master] section, select [Master] or [Sub].

Select [Master] to reflect the date and time settings made on the EB-50 to all the controllers in the M-NET system. The date and time cannot be set on the EB-50 if the [Time Master] setting is set to [Sub].

Note: Unless otherwise specified, select [Master].

### 4-2-4-2. Schedule: Season setting

In the [Schedule: Season setting] section, select [Available] to enable the weekly schedules and [Not Available] to disable. Unless otherwise specified, leave the default setting [Available] as it is.

Note: If the "Annual schedule, Weekly schedule" license has not been registered, the [Schedule: Season setting] section will not appear on the Basic System settings screen.

### 4-2-4-3. Hold type

In the [Hold type] section, select [Normal] or [Forced].

The Hold function is a function to disable the operations that were scheduled for air conditioning unit groups. If the setting for [Hold] is set to [ON] on the Condition List screen of the Web Browser for System Maintenance Engineer and the [Hold type] on the screen above is set to [Forced], the [Hold] setting can be cancelled only from the EB-50. If the [Hold type] is set to [Normal], the [Hold] setting can be cancelled from EB-50, other system controllers, or remote controllers.

Note: The Hold function can be used on the EB-50GU-A, but not on the EB-50GU-J.

Note: The Hold function cannot be used on general equipments.

Note: The setting [Forced] will not be effective on Air To Water (PWFY) unit groups, LOSSNAY unit groups, and air conditioning unit groups that do not support the Hold function (i.e., Mr. Slim M-Series/P-Series indoor units).

If the setting for [Hold] is set to [ON] on those unit groups on the Condition List screen and the [Hold type] on the screen above is set to [Forced], the setting [Normal] will be effective.

### 4-2-4-4. Old model compatibility mode

In the [Old model compatibility mode] section, select [ON] or [OFF].

Select [ON] to use the Old model compatibility mode.

When [ON] is selected, the Dual set point function cannot be used.

## 4-2-5. Network Settings

Network settings vary depending on whether the EB-50 is connected to a dedicated LAN or an existing LAN. See the sections below for how to set the EB-50 IP, subnet mask, and gateway addresses in the [Network Settings] section.

Network Settings				
IP Address	192	168	1	1
Subnet Mask	255	255	255	0
Gateway				
MAC Address	080070334242			

### 4-2-5-1. Settings for connecting the EB-50 to a dedicated LAN

- (1) Enter the EB-50's IP address in the [IP Address] field. If the LAN has been newly set up, allocate IP addresses to the EB-50 units in a sequential order starting with [192.168.1.1]. For example, the first EB-50 unit will have an IP address of [192.168.1.1], the second EB-50 unit will have an IP address of [192.168.1.2] and so on.

The EB-50's IP address must have the same network address as the PC's IP address.

Note: The recommended IP address ranges are as follows.

EB-50: Between [192.168.1.1] and [192.168.1.40]

PC: Between [192.168.1.101] and [192.168.1.150]

[IP address setting example]

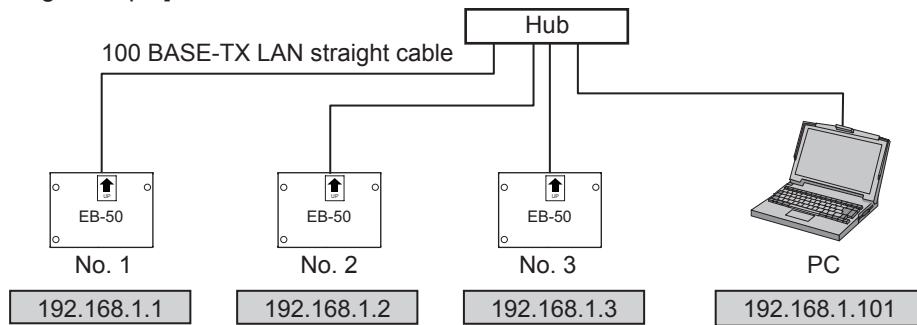

Note: Some hubs have dedicated ports for connection with another hub.

Connect the EB-50 and PC to the normal ports.

- (2) Enter [255.255.255.0] in the [Subnet Mask] field (unless otherwise specified).

- (3) When monitoring the system remotely or using e-mail function via a dial-up router, enter the router IP address in the [Gateway] field.  
 Leave the [Gateway] field blank when not connecting a dial-up router.

[Remote Monitoring System example]

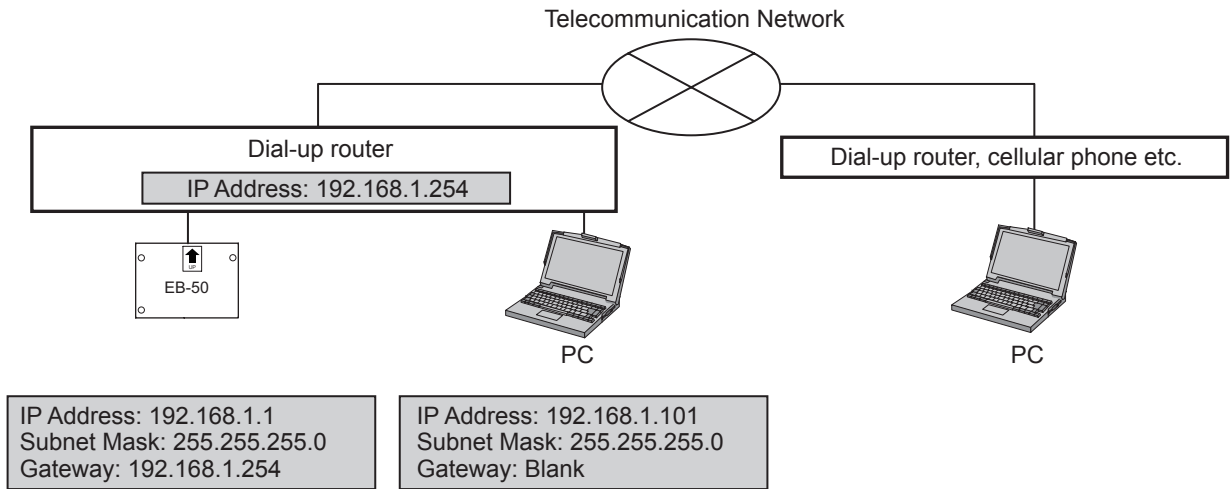

Note: [192.168.1.254] is recommended for use as the IP address of the dial-up router. Refer to the dial-up router instruction manual for details of how to set the IP address.

Note: The use of a dial-up router with no modem requires a modem (for analog or ISDN) to be connected between the router and the public phone line.

#### 4-2-5-2. Settings for connecting the EB-50 to an existing LAN

- (1) When connecting the EB-50 to an existing LAN, consult the system administrator to decide the IP, subnet mask, and gateway addresses.

[Existing LAN System example]

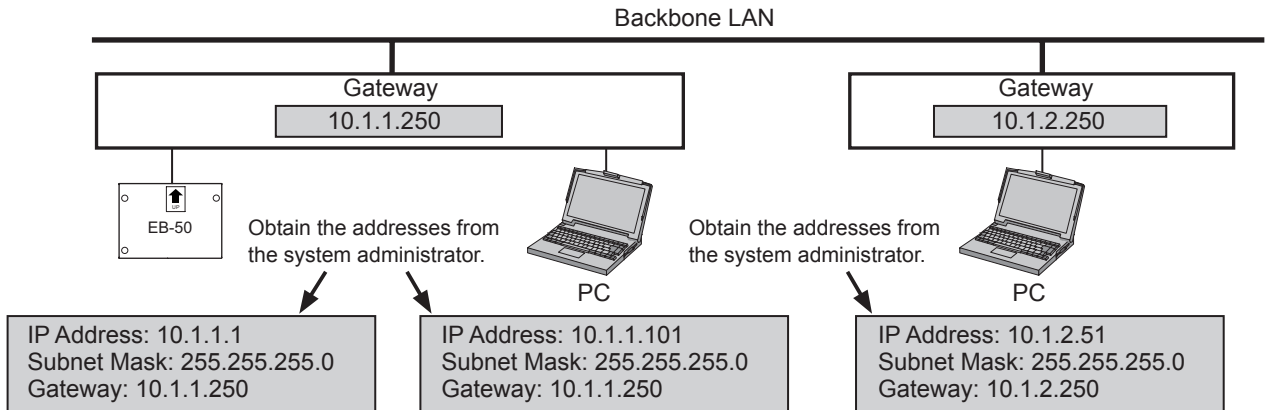

## 4-2-6. Display Format

Follow the instructions below to set the items in the [Display Format] section.

Display Format			
Unit of Temperature	<input checked="" type="checkbox"/> °C	<input type="checkbox"/> °F	
Pressure unit of measure	<input type="checkbox"/> MPa	<input checked="" type="checkbox"/> PSI	<input type="checkbox"/> kgf/cm <sup>2</sup>
Date Format	<input type="checkbox"/> 31/12/2012	<input type="checkbox"/> 12/31/2012	<input checked="" type="checkbox"/> 2012/12/31
Time Format	<input type="checkbox"/> 06:00 PM	<input checked="" type="checkbox"/> 18:00	
Group Names on Overview Monitor	<input checked="" type="checkbox"/> ON	<input type="checkbox"/> OFF	
Filter Sign Display	<input checked="" type="checkbox"/> ON	<input type="checkbox"/> OFF	
Room temp. display (except for group list)	<input checked="" type="checkbox"/> Always show	<input type="checkbox"/> Show during operation	<input type="checkbox"/> Hide
Occupancy sensor display	<input type="checkbox"/> Hide	<input type="checkbox"/> Show occupancy icon.	<input type="checkbox"/> Show vacancy icon.
Brightness sensor display	<input type="checkbox"/> Hide	<input type="checkbox"/> Show bright symbol.	<input type="checkbox"/> Show dark symbol.
Humidity sensor display	<input checked="" type="checkbox"/> ON	<input type="checkbox"/> OFF	

- (1) In the [Unit of Temperature] section, select [°C] or [°F].
- (2) In the [Pressure unit of measure] section, select [MPa], [PSI], or [kgf/cm<sup>2</sup>].
- (3) In the [Date Format] section, select the desired display format for year, month, and date.
- (4) In the [Time Format] section, select the desired display of time format.
- (5) In the [Group Names on Overview Monitor] section, select [ON] to display the group names under the icons on the Condition List screen. Select [OFF] not to display the group names.

Note: Only the first 8 characters will be visible under the icons. To display all characters, move the cursor to the icon.

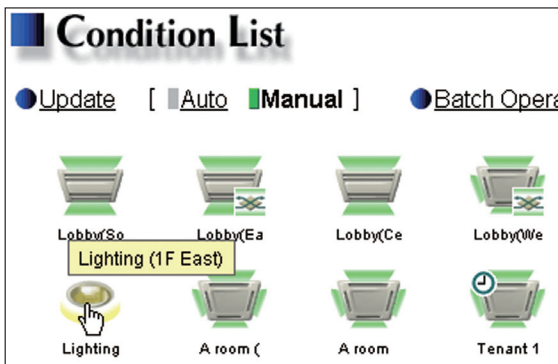

Icons with group names

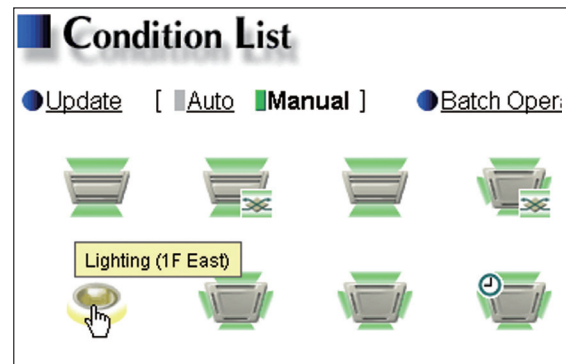

Icons without group names

- (6) In the [Filter Sign Display] section, select [ON] to display the filter sign, and select [OFF] not to. When the [Filter Sign Display] is set to [OFF], the filter sign will not appear on the Condition List screen even when the indoor unit detects a filter cleaning signal. If the filter is regularly cleaned and the sign display is unnecessary, set it to [OFF].
- (7) In the [Room temp. display (except for group list)] section, select the desired temperature display option to be used on the Block display of the Condition List screen. Select [Always show] to display the temperature at all times, [Show during operation] to display the temperature only during operation, and [Hide] not to display the temperature.

- (8) In the [Occupancy sensor display] section, make the Show/Hide setting for the occupancy/vacancy status that is detected by the built-in occupancy sensor on the ME remote controller (Smart ME controller).  
 Select [Hide] not to display the occupancy/vacancy status on the Condition List screen.  
 Select [Show occupancy icon] to display the occupancy icon when the sensor on the remote controller detects occupancy.  
 Select [Show vacancy icon] to display the vacancy icon when the sensor on the remote controller detects vacancy.  
 Select [Show both icons] to display the occupancy or vacancy icon according to the occupancy status of the room.

Note: If the ME remote controller has no built-in occupancy sensor, the occupancy/vacancy icons will not be displayed on the Condition List screen.

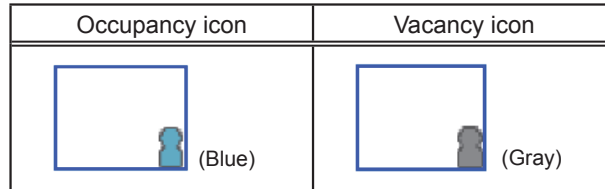

- (9) In the [Brightness sensor display] section, make the Show/Hide setting for the brightness/darkness status that is detected by the built-in brightness sensor on the ME remote controller (Smart ME controller).  
 Select [Hide] not to display the brightness/darkness icons on the Condition List screen.  
 Select [Show bright symbol] to display the brightness icon when the brightness level in the room reaches the predetermined brightness level.  
 Select [Show dark symbol] to display the darkness icon when the darkness level in the room reaches the predetermined darkness level.  
 Select [Show both symbols] to display the brightness or darkness icon according to the brightness/darkness level of the room.

Note: If the ME remote controller has no built-in brightness sensor, the brightness/darkness icons will not be displayed on the Condition List screen.

Note: The brightness/darkness detection thresholds are set on the ME remote controller (Smart ME controller).

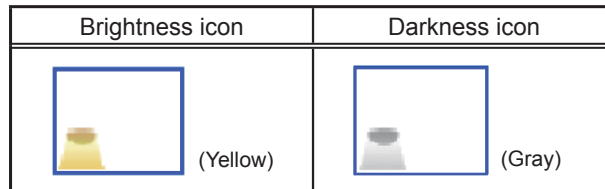

- (10) In the [Humidity sensor display] section, make the Show/Hide setting for the humidity reading of the built-in humidity sensor on the ME remote controller (Smart ME controller).  
 Select [ON] to display the humidity reading on the Block display of the Condition List screen.

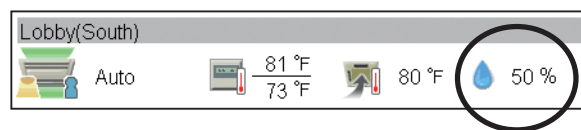

### 4-3. Groups

Click [Initial Settings] in the menu bar, and then click [Groups] to access the group settings screen. Register the groups of air conditioning units, ventilators (LOSSNAY), Air To Water (PWFY) units, AHC, or general equipment to be connected to the EB-50, and then click [Save Settings] to send the settings to the EB-50.

Note: Some settings may not be accessible if logged in as a building manager.

**Group No.** → Points to the 'Group No.' column header.

**Group name** → Points to the 'Group Name' column header.

**AHC registration**  
Click to display the screen for registering the AHC.

**Refresh**  
Click to import the settings from EB-50.

**Air conditioner, Air To Water (PWFY) unit, and general equipment registration**  
Click to display the screen for registering the air conditioners, Air To Water (PWFY) units, and general equipment.

**System controller registration**  
Click to display the screen for registering the system controllers.

**Remote controller registration**  
Click to display the screen for registering the remote controllers.

**Save Settings**  
Click to send the settings to EB-50.

#### 4-3-1. Setting group names

In the [Group Name] field, enter the group name to be displayed in 20 characters or less.

Note: The following characters cannot be used in the [Group Name] field: <, >, &, ", or '.

#### 4-3-2. Registering air conditioners, Air To Water (PWFY) units, or LOSSNAY units to a group

- To register air conditioners, Air To Water (PWFY) units, and LOSSNAY units to each group, click the [Air conditioner, Air To Water (PWFY) unit, and general equipment registration] field next to the target group name. The [Select Unit Addresses] screen will appear.

Check the radio button next to [Air-conditioners / Air to water], and select the address numbers of the units to be registered. The selected unit addresses will appear with a yellow-green background.

Click again to deselect. The deselected unit addresses will appear with a light-gray background.

Note: Each group can contain up to 16 air conditioners.

Note: Air conditioners, Air To Water (PWFY) units, and LOSSNAY units cannot be combined with general equipment in one group. To change the registered units to air conditioners, Air To Water (PWFY) units, or LOSSNAY units in the group in which general equipment is registered, unregister the general equipment first.

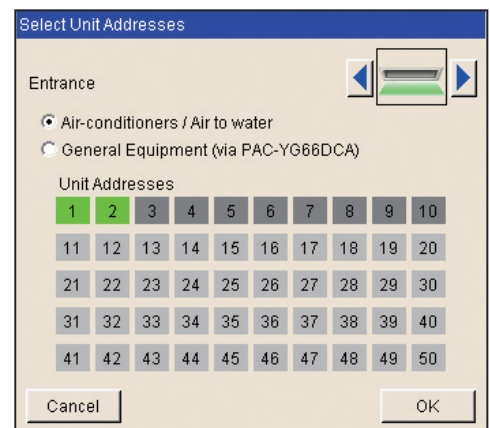

- To change the icon, click the right or left arrow. The selected icon will be displayed on the Web browser.



### 4-3-3. Registering remote controllers to a group

- To register remote controllers to a group, click the [Remote controller registration] field next to the target group name. The [Select Unit Addresses] screen will appear.

Select the address numbers of the remote controllers to be registered. The selected unit addresses will appear with a yellow-green background.

Click again to deselect. The deselected addresses will appear with a light-gray background.

Note: Each group can contain up to two remote controllers.

Note: Each group can contain up to four remote and system controllers combined.

Note: MA remote controllers do not need to be registered to a group.

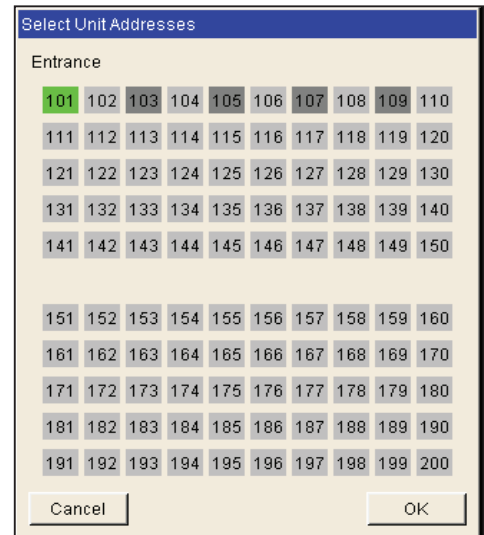

### 4-3-4. Registering system controllers to a group

- To register system controllers to a group, click the [System controller registration] field next to the target group name. The [Select Unit Addresses] screen will appear.

Select the address numbers of the system controllers to be registered. The selected unit addresses will appear with a yellow-green background.

Click again to deselect. The deselected addresses will appear with a light-gray background.

Note: Each group can contain up to four remote and system controllers combined.

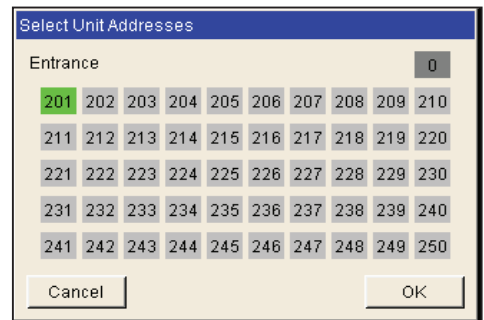

### 4-3-5. Registering AHC to a group

- To register an AHC to a group, click the [AHC registration] field next to the target group name. The [Select Unit Addresses] screen will appear.

Select the address number of the AHC to be registered. The selected unit address will appear with a yellow-green background.

Click again to deselect. The deselected address will appear with a light-gray background.

Note: Each group can contain one AHC.

Note: AHC must be registered to a group in which air conditioners are registered. Do not register AHC to a group in which Air To Water (PWFY) units or LOSSNAY units are registered.

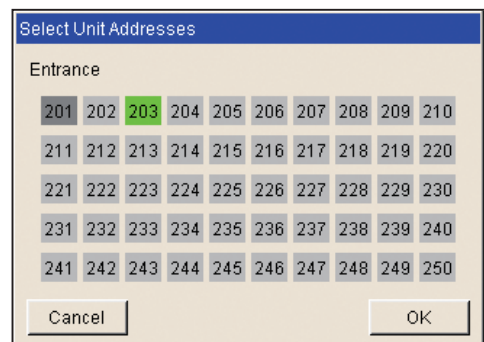

### 4-3-6. Registering general equipment to a group

- (1) To register general equipment to a group, click the [Air conditioner, Air To Water (PWFY) unit, and general equipment registration] field next to the target group name. The [Select Unit Addresses] screen will appear.

Check the radio button next to [General Equipment (via PAC-YG66DCA)].

Select the device number of the DIDO controller (PAC-YG66DCA) that is connected to the general equipment to be registered. The selected number will appear with a red frame. Also, select contact points to which the general equipments are connected.

Click again to deselect. The deselected numbers will appear with a light-gray background.

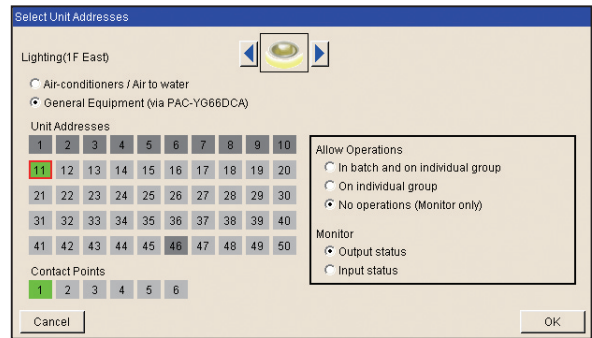

Note: Each group can contain up to 16 general equipments.

Note: Air conditioners, Air To Water (PWFY) units, and LOSSNAY units cannot be combined with general equipment in one group. To change the registered units to general equipment in the group to which air conditioners, Air To Water (PWFY) units, or LOSSNAY units are registered, unregister the air conditioners, Air To Water (PWFY) units, or LOSSNAY units first.

Note: Each contact of DIDO controller counts as one unit.

Note: General equipment groups cannot include remote controllers or system controllers.

- (2) To change the icon, click the right or left arrow.  
The selected icon will be displayed on the Web browser.
- (3) In the [Allow Operations] section, make the setting to allow or disallow operation.  
Select [In batch and on individual group] to allow the operator to turn on or off the general equipments collectively or by the groups.  
Select [On individual group] to allow the operator to turn on or off the general equipments by the groups.  
Select [No operations (Monitor only)] to disallow the operator to turn on or off the general equipment.
- (4) In the [Monitor] section, select which status will be used to reflect the units' ON/OFF status to the unit icons on the Condition List screen, accessible via the Web Browser for System Maintenance Engineer.  
Select [Output status] to use the status that is sent to the general equipment, and [Input status] to use the status that is sent from the general equipment.

## 4-4. Interlocked LOSSNAY

The ON/OFF status of the LOSSNAY unit can be interlocked with the operation of indoor units. Click [Initial Settings] in the menu bar, and then click [Interlocked LOSSNAY] to access the Interlocked LOSSNAY settings screen. Set the interlocking conditions, and then click [Save Settings] to send the settings to the EB-50.

Note: The Interlocked LOSSNAY settings may not be accessible if logged in as a building manager.

**Interlocked LOSSNAY unit registration**  
Click to display the screen for registering the LOSSNAY unit.

**Interlocked indoor unit registration**  
Click to display the screen for registering the indoor units.

**Refresh**  
Click to import the settings from EB-50.

**Save Settings**  
Click to send the settings to EB-50.

- Click the [Interlocked LOSSNAY unit registration] field. The [Select a Unit Address] screen will appear. Select the address number of the LOSSNAY unit to be registered. The selected unit address will appear with a yellow-green background. Click again to deselect. The deselected address will appear with a light-gray background.

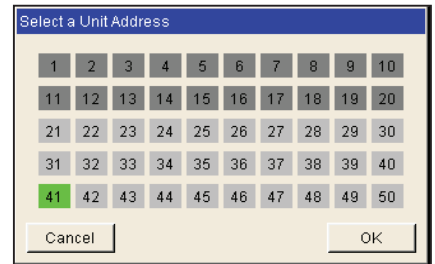

- Click the [Interlocked indoor unit registration] field. The [Select Unit Addresses] screen will appear. Select the address numbers of the indoor units to which the selected LOSSNAY unit will be interlocked. The selected unit addresses will appear with a yellow-green background. Click again to deselect. The deselected addresses will appear with a light-gray background.

Note: Each LOSSNAY unit can be interlocked with up to 16 indoor units.

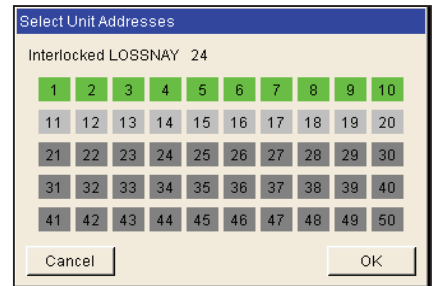

## 4-5. Blocks

By making block settings, multiple groups in a given block can be collectively monitored or operated on the Web browser. Click [Initial Settings] in the menu bar, and then click [Blocks] to access the block settings screen. Register the groups to each block, and then click [Save Settings] to send the settings to the EB-50.

Note: Some settings may not be accessible if logged in as a building manager.

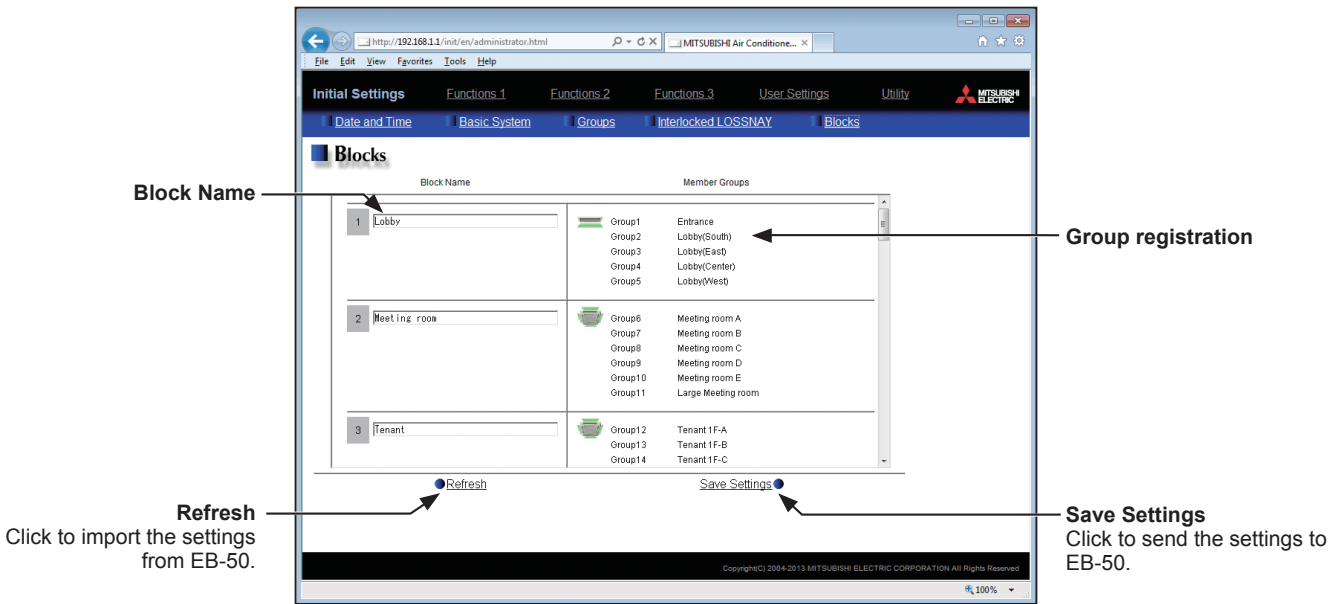

- (1) Enter the block name in the [Block Name] field to be displayed on the Web browser in 20 characters or less.

Note: The following characters cannot be used in the [Block Name] field: <, >, &, ", or '.

- (2) Click the [Group registration] field next to the target block. The [Select Groups] screen will appear. Select the group numbers to be registered. (To show the group name, move the cursor to the group number.) The selected group numbers will appear with a yellow-green background. Click again to deselect. The deselected group numbers will appear with a light-gray background.

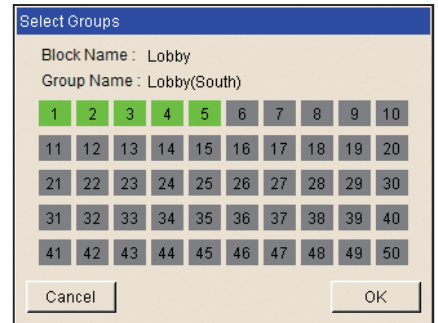

# 5. Functions 1

## 5-1. E-Mail

E-mail settings must be configured properly to use the error notification e-mail function or the e-mail communication function. Error notification e-mail function is the function to send the error information to the specified e-mail addresses. E-mail communication function is the function to send the units' maintenance data to the specified e-mail addresses of the PCs to which Maintenance Tool is installed.

Click [Functions 1] in the menu bar, and then click [E-Mail] to access the e-mail settings screen. Make the various e-mail settings, and then click [Save Settings] to send the settings to the EB-50.

Note: A separate license is required to send an error notification e-mail. Make sure that the required license has properly been registered on the Registration of Optional Functions screen. (Refer to chapter 10 for details.)

Note: The E-mail settings may not be accessible if logged in as a building manager.

**Mail Server Information**  
Set the mail server/DNS server information.

**Mail Communication Setting**  
Set the e-mail addresses of the PCs that will receive maintenance data through e-mail communication function.

**Refresh**  
Click to import the settings from EB-50.

**E-Mail Settings of EB-50GU-A**  
E-Mail Address [mitsubishi@eb50.co.jp]  
User ID [eb50]  
Password [\*\*\*\*\*]  
Interval of checking incoming mails [1] minute(s)

**Error Mail Settings**  
Enter the e-mail information for error notification e-mail function.

**Save Settings**  
Click to send the settings to EB-50.

### 5-1-1. E-Mail Settings of EB-50

E-Mail Settings of EB-50GU-A	
E-Mail Address	<input type="text" value="mitsubishi@eb50.co.jp"/>
User ID	<input type="text" value="eb50"/>
Password	<input type="password" value="*****"/>
Interval of checking incoming mails	<input type="text" value="1"/> minute(s)

Enter the EB-50's e-mail information provided by the Internet Service Provider (ISP) or the system administrator. The items required to be set vary, depending on the functions to be used. Refer to the table below to determine which items need to be set.

Note: A contract with the ISP is required to send e-mail via an ISP.

Table 5-1 Items required to be set (E-Mail Settings of EB-50)

Item	Error notification e-mail function		E-mail communication function	
	Without SMTP authentication	With SMTP authentication	Without SMTP authentication	With SMTP authentication
E-Mail Address	√	√	√	√
User ID	-	√	√	√
Password	-	√	√	√
Interval of checking incoming mails	-	-	√	√

(√) Required to be set, (-) Not required to be set

### 5-1-2. Mail Server Information

Mail Server Information	
Outgoing Mail Server (SMTP)	smtp.eb50.co.jp
	<input type="checkbox"/> Use SMTP Authentication
Incoming Mail Server (POP3) *1	pop.eb50.co.jp
DNS Server (Primary)	12 . 34 . 56 . 78
DNS Server (Secondary)	12 . 34 . 56 . 79

Enter the e-mail server information provided by the ISP or the system administrator. The items required to be set vary, depending on the functions to be used. Refer to the table below to determine which items need to be set. Either the IP address or the host name (server name) can be entered in the [Outgoing Mail Server (SMTP)] and [Incoming Mail Server (POP3)] fields.

Note: The port number of the Outgoing Mail Server (SMTP) is fixed to 25.

Table 5-2 Items required to be set (Mail Server Information)

Item	Error notification e-mail function		E-mail communication function	
	Without SMTP authentication	With SMTP authentication	Without SMTP authentication	With SMTP authentication
Outgoing Mail Server (SMTP)	√ IP address or host name	√ Host name	√ IP address or host name	√ Host name
Use SMTP Authentication	-	√	-	√
Incoming Mail Server (POP3)	-	-	√ IP address or host name	√ IP address or host name
DNS Server (Primary)	(√) *1	√	(√) *1	√
DNS Server (Secondary)	(√) *1	√	(√) *1	√

(√) Required to be set, (-) Not required to be set

\*1 Not required if the IP address is entered in the [Outgoing Mail Server (SMTP)] or [Incoming Mail Server (POP3)] field.

### 5-1-3. Error Mail Settings

Error Mail Settings	
Mail Subject	A/C Error at Mitsubishi Building
Kind of Errors	Unit Error
E-Mail Address	1 service@eb50.co.jp 2 3 4 5

(1) In the [Mail Subject] field, enter the mail subject to be used for the error notification e-mail function in 40 characters or less.

Note: The following characters cannot be used in the [Mail Subject] field: <, >, &, ", or '.

(2) In the [Kind of Errors] field, select the error type out of the following: [Unit Error], [Preliminary Unit Error], [Communication Error], [General Equipment], and [User Setting 1] through [User Setting 6]. Then, in the [E-Mail Address] field, enter the e-mail addresses of the recipients of the error notification e-mail.

- (3) If [User Setting 1] through [User Setting 6] is selected in the [Kind of Errors] field, a [User Settings] button will appear. To send error notification e-mail only upon occurrences of certain errors, click [User Settings] to display the User Settings screen. Enter the error codes to be notified.

Up to 20 error codes can be set for each user setting. In addition to specific error codes such as [1302] or [6607], codes that use asterisks as wildcards such as [10\*\*] or [12\*\*] can also be used. If [10\*\*] is entered, for example, error notification e-mail will be sent upon an occurrence of any type of errors between [1000] and [1099]. If error codes are entered on this screen, confirm that the e-mail addresses of the recipients are registered.

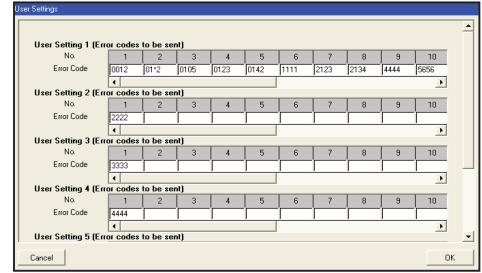

- (4) If [General Equipment] is selected in the [Kind of Errors] field, a [PLC Connection] button will appear. To send error notification e-mail upon occurrences of errors on the general equipment that are connected to PLC Software for General Equipment, click [PLC Connection] to display the [PLC Connection] screen. Enter the IP addresses of PLC Software for General Equipment.

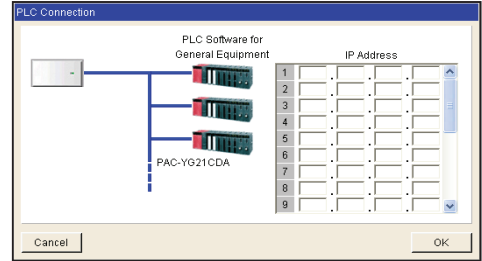

The row number that corresponds to each IP address will appear in the error notification e-mail as a PLC number. (e.g., When an error occurs on the general equipment #20 connected to the PLC Software in the second row, "PLC2-20" will appear in the [Error unit] section in the error notification e-mail.)

#### 5-1-4. Mail Communication Setting

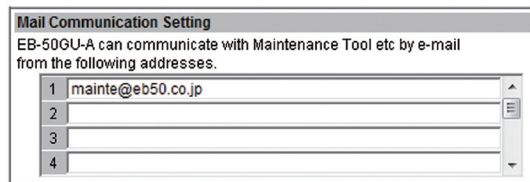

To use an e-mail communication function, enter the addresses of the PCs that will receive the units' maintenance data in the [Mail Communication Setting] section. Up to 10 e-mail addresses can be set.

### 5-1-5. E-mail format

Error notification e-mail will be sent in the format shown below.

From:Mitsubishi Building(000001)  
 Date:11/09/2005 16:32:12  
 Error unit:065  
 Error code:1302  
 Status:Occurrence

Mail subject	The mail subject entered in section 5-1-3 will appear.
From	The EB-50 unit name and unit ID entered in section 4-2-1 will appear.
Date	Error occurrence date and time will appear in the format entered in section 4-2-6.
Error unit	<ul style="list-style-type: none"> <li>- When an error occurs on air conditioning units or general equipment, the M-NET address of the unit in error will appear.</li> <li>- When an error occurs on general equipment connected to PLC Software for General Equipment, PLC number* (1 to 20) and connection number of general equipment (1 to 32) will appear.</li> <li>- When a communication error occurs on PLC Software for General Equipment, PLC number* (1 to 20) will appear.</li> </ul> <p>* PLC number indicates the row number on the [PLC Connection] screen. (Refer to section 5-1-3 (4).)</p> <p>Note: When an error occurs on the general equipment connected via DIDO controller, M-NET address of the DIDO controller will appear. (The recipients will know that an error has occurred on one of the general equipment that is connected to the DIDO controller.)</p>
Error code	<p>Error code (4-digit) will appear.</p> <ul style="list-style-type: none"> <li>- When an error occurs on air conditioning units, refer to the service manual of the unit for the error codes.</li> <li>- When an error occurs on general equipment, "0091" (General equipment error) will appear.</li> <li>- When a communication error occurs on PLC Software for General Equipment, "0003" (LAN communication error to PLC) or "0007" (PLC program stopped) will appear.</li> </ul>
Status	Error status "Occurrence" (The error is occurring) or "Recovery" (The error has been resolved) will appear.



## 5-2. Peak Cut (Energy-save control function)

According to the selected Peak Cut method, the EB-50 obtains the demand level or the electric energy values to determine the control level, and operates outdoor units and blocks of indoor units below the specified maximum capacity that corresponds to the control level.

Click [Functions 1] in the menu bar, and then click [Peak Cut] to access the Peak Cut control settings screen. Make necessary settings, and then click [Save Settings] to send the settings to the EB-50.

Note: After completing the settings, perform a test run and confirm proper connections of equipment before using the Peak Cut function.

Note: A separate license is required to use the Peak Cut function. Make sure that the required license has properly been registered on the Registration of Optional Functions screen. (Refer to chapter 10 for details.)

Note: Some settings may not be accessible if logged in as a building manager.

Note: Peak Cut control cannot be performed on DIDO controller (PAC-YG66DCA), AHC, or Air To Water (PWFY) unit.

The screenshot shows the 'Peak Cut' configuration interface. It includes a navigation menu at the top with 'Functions 1' selected. The main area is divided into 'System settings', 'Control details for outdoor units', and 'Control details for indoor units'. The 'System settings' section includes 'Demand Input PLC', 'Electric Amount Count PLC', 'PI Controller', and 'Remote EB-50'. The 'Control details for outdoor units' section shows a table with columns for 'Address', 'Maximum Capacity', and 'Control Time (per 30 minutes)'. The 'Control details for indoor units' section shows a table for 'Block 1 Lobby' with columns for 'Control Method' and 'Control Time (per 30 minutes)'. A 'Refresh' button is located at the bottom left, and a 'Save Settings' button is at the bottom right. Annotations with arrows point to these key elements.

**Peak Cut method** → Points to the 'System settings' section.

**Setting details for the selected Peak Cut method** → Points to the 'Control levels' table.

**Control details for outdoor units** → Points to the 'Control details for outdoor units' table.

**Control details for blocks of indoor units** → Points to the 'Control details for indoor units' table.

**Refresh** → Points to the 'Refresh' button. Click to import the settings from EB-50 and PLC.

**Save Settings** → Points to the 'Save Settings' button. Click to send the settings to EB-50 and PLC.

**Peak Cut method [Demand-Input PLC]**

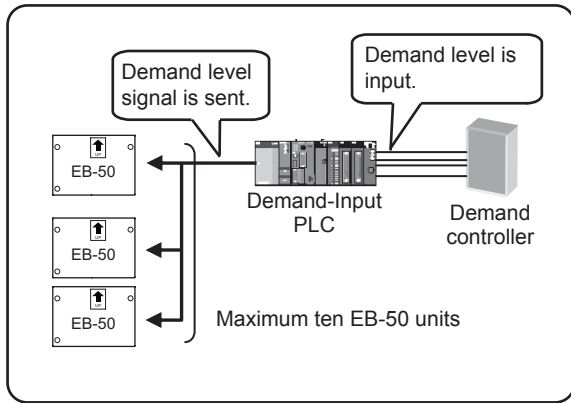

**Peak Cut method [Electric Amount Count PLC]**

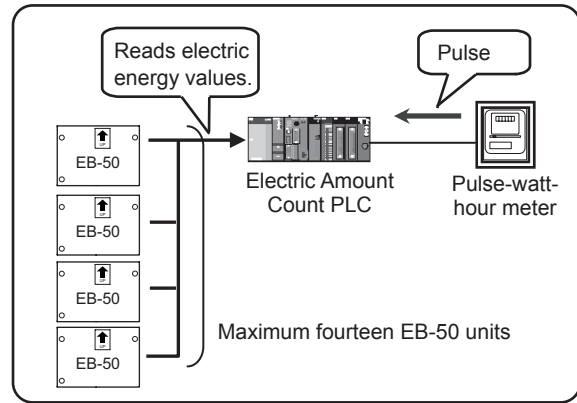

**Peak Cut method [PI Controller]**

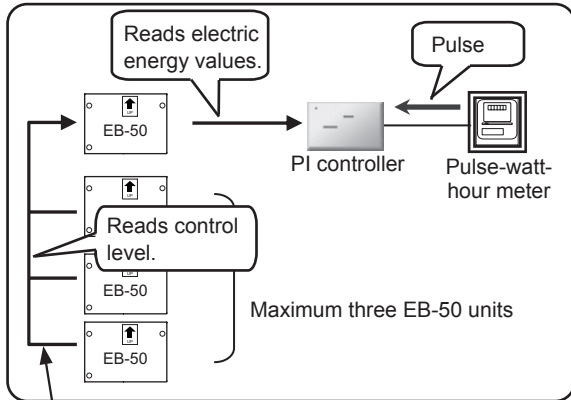

**Peak Cut method [From external system]**

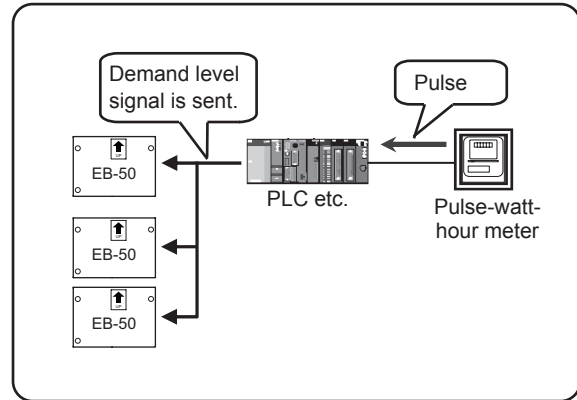

**Peak Cut method [Remote EB-50]**

Important: The amount of electricity that is actually used may exceed the maximum power demand due to unexpected problems such as controller malfunctions or broken transmission cables. Mitsubishi Electric will not be responsible for exceeding the maximum power demand.

**5-2-1. Peak Cut method**

**(A) When the Peak Cut method [Demand-Input PLC] is selected**

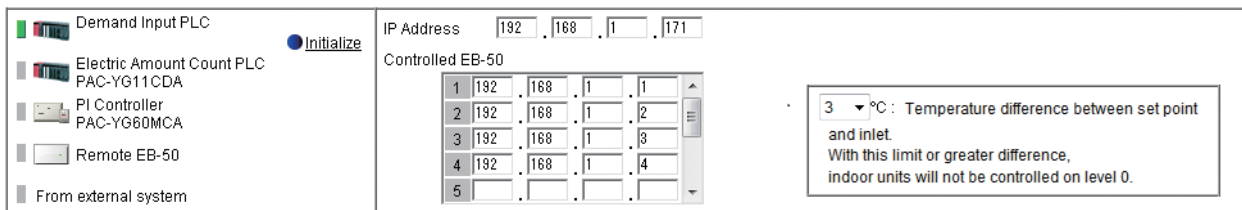

- (1) When using the Demand-Input PLC for the first time, click [Initialize] to initialize its internal memory.  
Note: Do not initialize the Demand-Input PLC after the operation has begun, for it will clear all operation data.
- (2) In the [IP Address] field, enter the IP address of the Demand-Input PLC.
- (3) In the [Controlled EB-50] field, enter the IP addresses of the EB-50 units to which the demand level signal is sent. Up to 10 IP addresses can be registered.
- (4) In the [Temperature difference between set point and inlet] section, a temperature differential can be set to between 3 and 9 as necessary. The Peak Cut control setting that corresponds to the control level 0 will be disregarded for the indoor unit groups in which the temperature difference between the set temperature and the room temperature is greater than the specified temperature differential.

**(B) When the Peak Cut method [Electric Amount Count PLC] is selected**

<input type="checkbox"/> Demand Input PLC PAC-YG41CDA <input checked="" type="checkbox"/> Electric Amount Count PLC <input type="checkbox"/> PI Controller PAC-YG60MCA <input type="checkbox"/> Remote EB-50 <input type="checkbox"/> From external system	IP Address: [192] . [188] . [1] . [151] DI Board: [1] - [0] Pulse Unit: [0] . [1] kWh / pulse Control levels: <table border="1"> <tr><td>4</td><td>[180]</td><td>kW</td><td>-</td></tr> <tr><td>3</td><td>[160]</td><td>kW</td><td>- 180 kW</td></tr> <tr><td>2</td><td>[140]</td><td>kW</td><td>- 160 kW</td></tr> <tr><td>1</td><td>[120]</td><td>kW</td><td>- 140 kW</td></tr> <tr><td>0</td><td>0</td><td>kW</td><td>- 120 kW</td></tr> </table>	4	[180]	kW	-	3	[160]	kW	- 180 kW	2	[140]	kW	- 160 kW	1	[120]	kW	- 140 kW	0	0	kW	- 120 kW	<input type="button" value="Initialize"/> <div style="border: 1px solid black; padding: 5px;">         3 °C : Temperature difference between set point and inlet.          With this limit or greater difference, indoor units will not be controlled on level 0.       </div>
4	[180]	kW	-																			
3	[160]	kW	- 180 kW																			
2	[140]	kW	- 160 kW																			
1	[120]	kW	- 140 kW																			
0	0	kW	- 120 kW																			

- (1) When using the Electric Amount Count PLC for the first time, click [Initialize] to initialize the internal memory.

Note: Do not initialize the Electric Amount Count PLC after the operation has begun, for it will clear all operation data.

- (2) In the [IP address] field, enter the IP address of the Electric Amount Count PLC.
- (3) In the [DI Board] field, select the DI board number to which the watt-hour meter is connected, and the terminal number. If the watt-hour meter is connected to terminal 2 on a DI board 1, select 1-2.

Note: Select a DI board number 1 or 2, and select a terminal number/code between 0 and F.

- (4) In the [Pulse Unit] field, enter the pulse value that the watt-hour meter outputs. Set the pulse value according to the watt-hour meter to be used.

Important: Check the watt-hour meter readings several times on the hour and the half-hour. Then, be sure to check that the increase in the watt-hour meter reading for each 30-minute period and the average electric power consumption in the same period that the Peak Cut function is used are the same amount.

The average electric power for the period that the Peak Cut function is used can be checked on the Trend Graph display or in the CSV file that can be downloaded from the Trend Graph display. The Trend Graph display can be found on the Peakcut Control Status screen, accessible via the Web Browser for System Maintenance Engineer. Refer to the Instruction Book (Web Browser for System Maintenance Engineer) for details.

- (5) In the [Control levels] section, the range of the electric power must be set for each control level. For control level 4, enter the value that is 10% to 15% below the maximum power demand (average electric energy that cannot be exceeded in any 30-minute period). For control levels 3 to 0, enter the value that is decreased by about 10% from the set value of the previous control level. (The screenshot above shows the setting example of the maximum demand of 200 kW.)

Note: The optimum setting depends on the system configuration of the electric equipment and on the indoor environment in each building. Determine the appropriate values accordingly.

- (6) In the [Temperature difference between set point and inlet] section, a temperature differential can be set to between 3 and 9 as necessary. The Peak Cut control setting that corresponds to the control level 0 will be disregarded for the indoor unit groups in which the temperature difference between the set temperature and the room temperature is greater than the specified temperature differential.

**(C) When the Peak Cut method [PI Controller] is selected**

<input type="checkbox"/> Demand Input PLC PAC-YG41CDA <input type="checkbox"/> Electric Amount Count PLC PAC-YG11CDA <input checked="" type="checkbox"/> PI Controller PAC-YG60MCA <input type="checkbox"/> Remote EB-50 <input type="checkbox"/> From external system	Watthour meter: Address50-4 Whm (Peakcut) Control levels: <table border="1"> <tr><td>4</td><td>[180]</td><td>kW</td><td>-</td></tr> <tr><td>3</td><td>[160]</td><td>kW</td><td>- 180 kW</td></tr> <tr><td>2</td><td>[140]</td><td>kW</td><td>- 160 kW</td></tr> <tr><td>1</td><td>[120]</td><td>kW</td><td>- 140 kW</td></tr> <tr><td>0</td><td>0</td><td>kW</td><td>- 120 kW</td></tr> </table>	4	[180]	kW	-	3	[160]	kW	- 180 kW	2	[140]	kW	- 160 kW	1	[120]	kW	- 140 kW	0	0	kW	- 120 kW	<div style="border: 1px solid black; padding: 5px;">         3 °C : Temperature difference between set point and inlet.          With this limit or greater difference, indoor units will not be controlled on level 0.       </div>
4	[180]	kW	-																			
3	[160]	kW	- 180 kW																			
2	[140]	kW	- 160 kW																			
1	[120]	kW	- 140 kW																			
0	0	kW	- 120 kW																			

- (1) In the [Watthour meter] field, select the PI controller to which the watt-hour meter used for the Peak Cut function is connected.

Note: Only the watt-hour meters that have been registered on the Measurement screen are selectable. Refer to section 5-3 for how to register metering devices.

- (2) In the [Control levels] section, the range of the electric power must be set for each control level. For control level 4, enter the value that is 10% to 15% below the maximum power demand (average electric energy that cannot be exceeded in any 30-minute period). For control levels 3 to 0, enter the value that is decreased by about 10% from the set value of the previous control level. (The screenshot above shows the setting example of the maximum demand of 200 kW.)

Note: The optimum setting depends on the system configuration of the electric equipment and on the indoor environment in each building. Determine the appropriate values accordingly.

- (3) In the [Temperature difference between set point and inlet] section, a temperature differential can be set to between 3 and 9 as necessary. The Peak Cut control setting that corresponds to the control level 0 will be disregarded for the indoor unit groups in which the temperature difference between the set temperature and the room temperature is greater than the specified temperature differential.

#### (D) When the Peak Cut method [Remote EB-50] is selected

<ul style="list-style-type: none"> <li><input type="checkbox"/> Demand Input PLC PAC-YG41CDA</li> <li><input type="checkbox"/> Electric Amount Count PLC PAC-YG11CDA</li> <li><input type="checkbox"/> PI Controller PAC-YG60MCA</li> <li><input checked="" type="checkbox"/> Remote EB-50</li> <li><input type="checkbox"/> From external system</li> </ul>	<p>IP Address    <input type="text" value="192"/> . <input type="text" value="168"/> . <input type="text" value="1"/> . <input type="text" value="1"/></p> <div style="border: 1px solid black; padding: 5px; margin-top: 10px;"> <p>3 °C : Temperature difference between set point and inlet. With this limit or greater difference, indoor units will not be controlled on level 0.</p> </div>
--	---

- (1) In the [IP address] field, enter the IP address of the EB-50 to which the PI controller (with connection to the watt-hour meter used for the Peak Cut function) is connected.

Note: As the control level is obtained every minute from the EB-50 to which the PI controller is connected, the control level change will not be reflected in real time.

Note: Up to three EB-50 units can be connected to the EB-50 unit to which the PI controller is connected. When five or more EB-50 units are used, use the Peak Cut method [Electric Amount Count PLC].

- (2) In the [Temperature difference between set point and inlet] section, a temperature differential can be set to between 3 and 9 as necessary. The Peak Cut control setting that corresponds to the control level 0 will be disregarded for the indoor unit groups in which the temperature difference between the set temperature and the room temperature is greater than the specified temperature differential.

#### (E) When the Peak Cut method [From external system] is selected

<ul style="list-style-type: none"> <li><input type="checkbox"/> Demand Input PLC PAC-YG41CDA</li> <li><input type="checkbox"/> Electric Amount Count PLC PAC-YG11CDA</li> <li><input type="checkbox"/> PI Controller PAC-YG60MCA</li> <li><input type="checkbox"/> Remote EB-50</li> <li><input checked="" type="checkbox"/> From external system</li> </ul>	<div style="border: 1px solid black; padding: 5px; margin-top: 10px;"> <p>3 °C : Temperature difference between set point and inlet. With this limit or greater difference, indoor units will not be controlled on level 0.</p> </div>
--	--

- (1) In the [Temperature difference between set point and inlet] section, a temperature differential can be set to between 3 and 9 as necessary. The Peak Cut control setting that corresponds to the control level 0 will be disregarded for the indoor unit groups in which the temperature difference between the set temperature and the room temperature is greater than the specified temperature differential.

## 5-2-2. Control details for outdoor units (All Peak Cut methods)

Follow the instructions below to make the Peak Cut control settings for each control level for given outdoor units.

Note: If the outdoor unit is a City Multi unit, the M-NET address will appear. If the outdoor unit is an A-control (Mr. Slim) unit, the M-NET address and group name will appear.

Note: As for A-control outdoor units, only the inverter models can perform Peak Cut control. The Peak Cut control settings for constant-speed models can not be made.

Control level	Maximum Capacity					Control Time (per 30 minutes)				
4	100%	90%	80%	70%	60%	3	6	9	15	30
3	100%	90%	80%	70%	60%	3	6	9	15	30
2	100%	90%	80%	70%	60%	3	6	9	15	30
1	100%	90%	80%	70%	60%	3	6	9	15	30
0	100%	90%	80%	70%	60%	3	6	9	15	30

**Batch Operations**  
Click to make settings for all outdoor units at once.

**Maximum Capacity**  
Select the upper limit of outdoor unit operating capacity.

- Scroll up or down to display the outdoor unit whose settings are to be made. To make settings for all outdoor units at once, check the [Batch Operations] checkbox. Then, set the maximum operating capacity for each control level. Outdoor units normally operate at the capacity of 100%. The smaller the maximum operating capacity, the more energy will be saved.

Note: Energy-saving effects cannot be expected during low-load operation with the capacity below the selected maximum capacity.

Note: For City Multi S series (PUMY) outdoor units, leave the default setting [100%] as it is not to activate the capacity-save control.

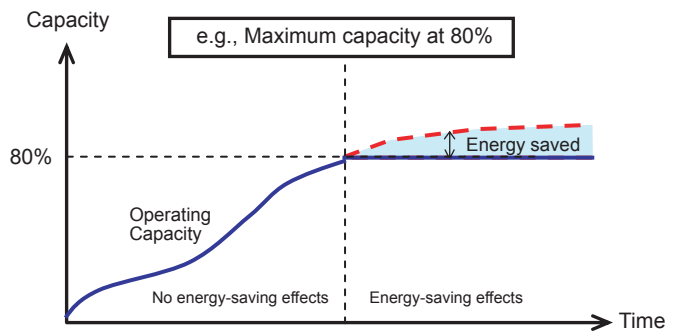

- For each control level, set the total time in which the Peak Cut control is performed during every 30 minutes. Setting the time to [30] or [15] minutes is preferable, for shorter control time is not likely to bring much benefit. If any time other than [30] minutes is selected, the outdoor units will operate in rotation so that they will not perform the Peak Cut control at the same time.
- To copy the settings of an outdoor unit to the settings for other outdoor units, display the outdoor unit whose settings are to be copied and click [Copy], then display the outdoor unit to which the copied settings are to be pasted and click [Paste]. The rectangular icons next to the selected buttons will appear in yellow-green.

### 5-2-3. Control details for blocks of indoor units (All Peak Cut methods)

Follow the instructions below to make the Peak Cut control settings for each control level for given blocks of indoor units.

If the block settings have not been made, refer to section 4-5 for how to make the block settings.

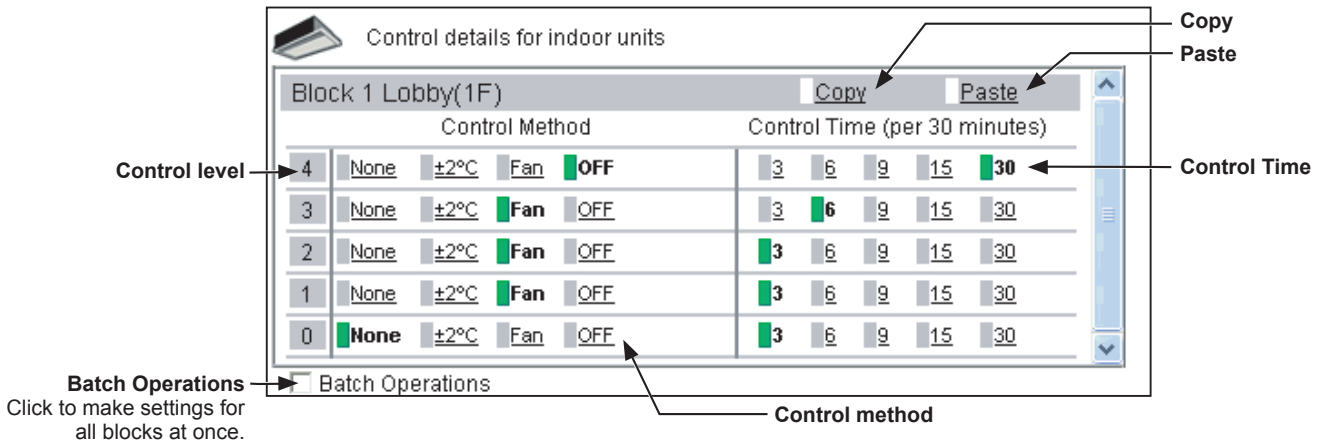

- Scroll up or down to display the block whose settings are to be made. To make settings for all blocks at once, check the [Batch Operations] checkbox.

Then, select the control method for each control level, referring to the table below.

Note: Only the control method "OFF" is effective for Air To Water (PWFY) units. Other methods can be selected, but are not effective.

Table 5-3 Indoor Unit Control Method

Control Method	Control details
None	Peak Cut control will not be performed.
±2°C (±4°F)	<p>During the Peak Cut control, the set temperature in the Cool or Dry mode will be offset by +2°C (+4°F), and the set temperature in the Heat mode will be offset by -2°C (-4°F).</p> <p>Note: Peak Cut control will not be performed during the Fan or Auto mode.</p> <p>Note: When the unit of temperature is Fahrenheit, the set temperature may not be offset by ±4°F exactly because 2°C is used for the calculation first, and then the temperature in Celsius is converted into the temperature in Fahrenheit.</p> <p>Note: The set temperature will be adjusted within the set temperature restrictions settings. Refer to section 6-1 for details.</p>
Fan	During the Peak Cut control, free-plan indoor units and A-control Mr. Slim indoor units (M-Series/ P-Series indoor units) will go in to the Thermo-OFF state, and the units older than free-plan units will operate in the Fan mode. (When the units are in the Thermo-OFF state, the operation mode on the remote controller LCD will not change, and the user will not notice that the Peak Cut control is being performed.)
OFF	<p>During the Peak Cut control, the units will stop.</p> <p>Note: If the control method is set to [OFF] and the Control Time is set to [30] minutes, the groups that are operated in the Peak Cut control cannot be operated from any controller.</p>

- For each control level, set the total time in which the Peak Cut control is performed during every 30 minutes.

Each Peak Cut control is performed for three minutes. If [6] minutes is selected, three-minute Peak Cut control will be performed twice during every 30 minutes.

If any time other than [30] minutes is selected, the indoor units will operate in rotation so that they will not perform the Peak Cut control at the same time.

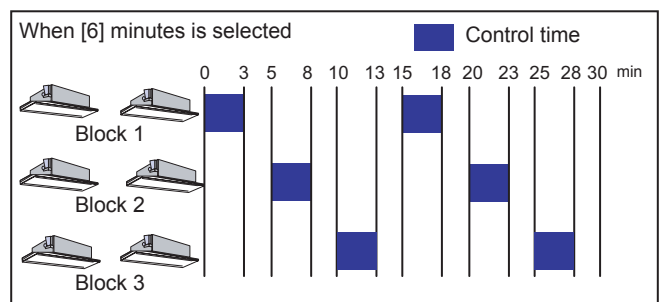

- (3) To copy the settings of a block to the settings for other blocks, display the block whose settings are to be copied and click [Copy], then display the block to which the copied settings are to be pasted and click [Paste]. The rectangular icons next to the selected buttons will appear in yellow-green.



## 5-3. Measurement

Measurement settings must be made to use temperature sensors, humidity sensors, and metering devices. Click [Functions 1] in the menu bar, and then click [Measurement] to access the measurement settings screen. Set the measurement settings, and then click [Save Settings] to send the settings to the EB-50.

Note: The measurement settings may not be accessible if logged in as a building manager.

**Selection of AI or PI controller**

**M-NET address of AI or PI controller**

**Selection of separator character for energy management data**

**Selection of decimal point character for energy management data**

**Refresh**  
Click to import the settings from EB-50.

**Setting details**

**Scroll bar**  
Slide to show the address to which the AI or PI controller will be connected.

**E-mail Settings**

**Save Settings**  
Click to send the settings to EB-50.

### 5-3-1. Registering AI controllers and temperature/humidity sensors

Follow the instructions below to make the system settings for measurement sensors. Up to two measurement sensors can be connected to an AI controller (PAC-YG63MCA).

**Sensor name**

**AI controller icon**

**Setting details of sensor 1**

**Setting details of sensor 2**

**Selection of temperature or humidity sensor icon**

**Measurable range**

**Upper/lower ON- and OFF-threshold settings for e-mail alarm function**



**Upper limit (ON-threshold)**

**Upper limit (OFF-threshold)**

**Lower limit (OFF-threshold)**

**Lower limit (ON-threshold)**

**Set offset**

- (1) Using the scroll bar, select the address to which the AI controller (PAC-YG63MCA) will be connected.
- (2) Select the AI controller icon (  ).  
Note: Click again to deselect.
- (3) In the [Sensor name] field, enter the name of the sensor.
- (4) Select the temperature sensor icon (  ) or the humidity sensor icon (  ).
- (5) Enter the measurable range of the sensor.

Note: When the Pt sensor is connected, the range must be between -30°C (-22°F) and +60°C (+140°F).

When the sensors other than the Pt sensors are connected, enter the ranges that are described in the operation manuals of the sensor.



- To receive an e-mail alarm when the temperature or the humidity exceeds certain predetermined values, set the ON- and OFF-thresholds for both the upper and lower limit temperatures.

Note: To avoid frequent ON/OFF cycling, the minimum differential between the ON- and OFF-threshold values should be 1°C (2°F).

### 5-3-2. Offsetting the measured temperature/humidity values

To set the offset value for the measured values, follow the instructions below.

Note: The actual measurement values or the adjusted measurement values are not displayed until the connection settings of the AI controller are completed.

When the AI controller is registered for the first time, click [Save Settings] to send the settings data, and click [Functions 1]-[Measurement] to refresh the measurement settings screen.

- Click [Set offset] in the [Setting details] section.
- Select the offset value in the [Offset] pulldown menu, or select the desired value in the [Modified value] pulldown menu.

The settable offset value range for temperature sensor is between -10.0°C (-18.0°F) and +10.0°C (+18.0°F), and for the humidity sensor is between -10.0% and +10.0%.

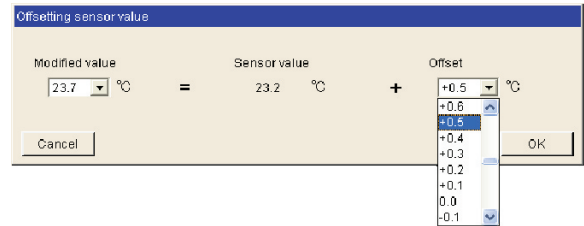

### 5-3-3. Registering PI controllers and metering devices

Follow the instructions below to make the system settings of the metering devices. Up to four metering devices can be connected to a PI controller (PAC-YG60MCA).

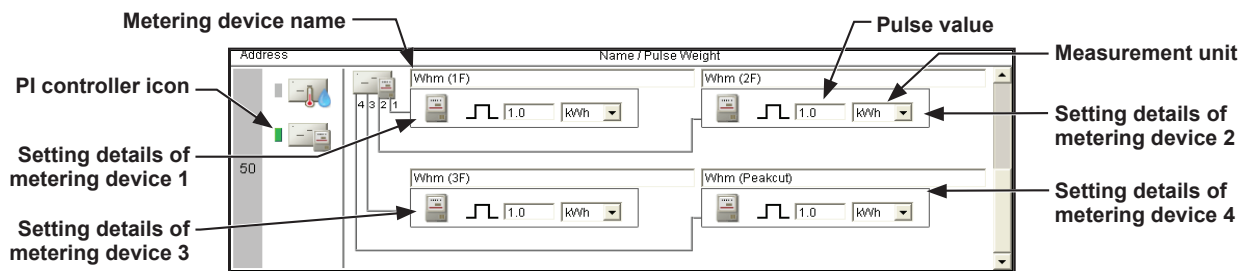

- Using the scroll bar, select the address to which the PI controller (PAC-YG60MCA) will be connected.
- Select the PI controller icon (  ).  
Note: Click again to deselect.
- In the [Metering device name] field, enter the name of the metering device.
- Enter the pulse value of the metering device, and select the measurement unit.

Note: The measurement unit can be selected from [kWh], [m3], [MJ], or [--(no unit)].

Note: Select the blank in the measurement unit pulldown menu when not using a metering device.

**Important:** Set the pulse value according to the metering device to be used. To ensure proper settings, first check the value measured by the metering device and the value counted by the PI controller. Then, after a certain time, check that both values have increased by equal values. (The values that the PI controller counts can be checked on the Web Browser for System Maintenance Engineer.)

### 5-3-4. E-mail alarm function settings

To receive an e-mail alarm when the temperature or the humidity exceeds certain predetermined values, set the e-mail settings by following the instructions below.

- In the [Type of E-Mail] field, select [Out-of-limit alarm].  
Then, enter the mail subject and the e-mail addresses.

Note: The following characters cannot be used in the [Mail Subject] field: <, >, &, ", or '

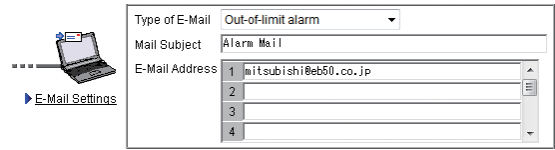

An e-mail alarm will be sent in the format shown below.

```
From: Mitsubishi Building(000001)
Date/Time: 20/04/2012 09:38:39
Address: 50-1
Current value: 24.9 deg C
Status: Exceeded lower limit
Trend Data:
09:38 25.2 deg C
09:37 25.4 deg C
09:36 25.6 deg C
09:35 25.8 deg C
09:34 26.1 deg C
09:33 26.4 deg C
09:32 26.7 deg C
09:31 27.0 deg C
09:30 27.5 deg C
09:29 27.7 deg C
```

From	EB-50 name + Unit ID Note: The EB-50 unit name and unit ID entered in section 4-2-1 will appear.
Date/Time	yyyy/mm/dd hh:mm:ss Note: The date and time will appear in the format selected in section 4-2-6.
Address	M-NET address of AI controller + sensor No.
Current value	Current temperature or humidity (one decimal place) Note: [*. *] may appear until the value measured by sensor becomes stable.
Status	"Exceeded upper limit," "Recovered from upper limit," "Exceeded lower limit," or "Recovered from lower limit"
Trend Data	Time + Temperature or humidity values (for the last 10 minutes)

- Click [E-Mail Settings] to enter the mail server information.

Note: The setting details are the same as those described in sections 5-1-1 and 5-1-2. Refer to those sections for details.

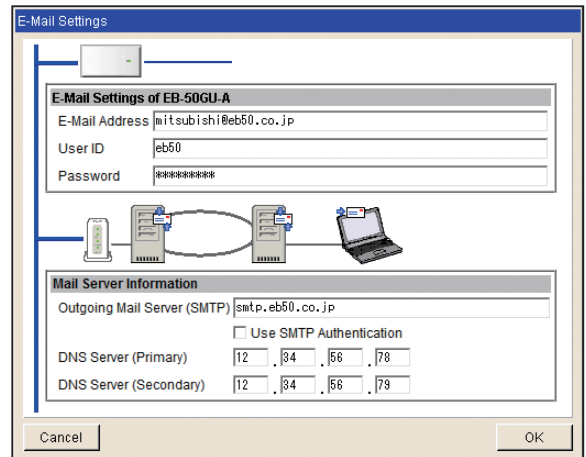

### 5-3-5. Energy management data format settings

Set the format of the energy management data that can be output in a CSV format from the screens under the Energy Management menu, accessible via the Web Browser for System Maintenance Engineer.

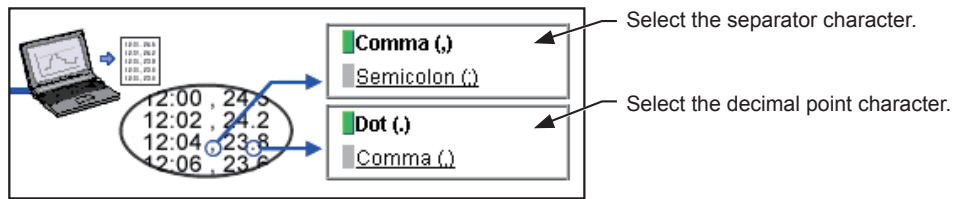

## 5-4. Energy Management Settings

On the Energy Management Settings screen, make the settings for the energy-control-related items that appear on the screens under the Energy Management menu (accessible via the Web browser for System Maintenance Engineer), such as temperature sensor to measure the outdoor temperature with, electricity meters that are used for acquiring the data to display the trend graph of indoor unit electricity consumption, and also the mode that are used for apportioning indoor unit electricity consumption.

Click [Functions 1] in the menu bar, and then click [Energy Management Settings] to access the energy management settings screen.

Note: The energy management settings may not be accessible if logged in as a building manager.

Important: The energy management settings must be made after all units have been started up.  
The settings that have been saved while one or more units are starting up may be lost.

The screenshot shows the 'Energy Management Settings' page in a web browser. The page has a navigation bar with 'Functions 1' selected. The main content area is divided into sections: 'External Temperature Sensor', 'Indoor unit operation apportioning mode', and 'Indoor unit electricity meter'. The 'Indoor unit electricity meter' section contains a table with columns for 'Address', 'Group Name', and 'Electricity meter'. Callouts point to various elements: 'Temperature sensor' (dropdown menu), 'Indoor unit operation apportioning mode' (radio buttons), 'Indoor unit electricity meter' (table), 'Indoor unit address' (table row), 'Group Name' (table column), 'Electricity meter' (table column), 'Refresh' (button), and 'Save Settings' (button).

Address	Group Name	Electricity meter
1	Entrance	Address50-1 Electric Meter1
2	Lobby(South)	Address50-1 Electric Meter1
3	Lobby(East)	Address50-1 Electric Meter1
4	Lobby(Center)	Address50-1 Electric Meter1
5	Lobby(West)	Address50-1 Electric Meter1
6	Conference Room A	Address50-2 Electric Meter2
7	Conference Room B	Address50-2 Electric Meter2
8	Conference Room C	Address50-3 Electric Meter3
9	Conference Room D	Address50-3 Electric Meter3
10	Conference Room E	Address50-4 Electric Meter4
11	Conference Room F	Address50-4 Electric Meter4

- (1) In the [Temperature sensor] section, select a temperature sensor to measure the outdoor temperature with. In the pulldown menu, the name of the temperature sensor that is connected to the AI controller or the AHC will appear.

Note: Connect the temperature sensor to either the Analog Input 1 or Analog Input 2 port on the AHC.

- (2) In the [Indoor unit operation apportioning mode] section, select the way indoor units' operation time is counted that is used to apportion the electricity consumption, which appears on the screens under the Energy Management menu, accessible via the Web Browser for System Maintenance Engineer. Select [Fan operation time] to apportion the electricity consumption based on the fan operation time, and select [Thermo-ON time] to apportion the electricity consumption based on the Thermo-ON time of the indoor units.

Select [Capacity save amount] to apportion the electricity consumption based on the indoor unit operation time that was calculated based on the amount of energy saved on the indoor units.

The selected setting must meet the system requirements. Selecting [Capacity save amount] is recommended.

Note: "FAN operation time" is the cumulative duration of time in which the indoor unit is powered on.

Note: "Thermo-ON time" is the cumulative duration of time in which the compressor is powered on.

Note: "Capacity save amount" is the cumulative operation time of the indoor unit based on its capacity (coefficient).

(3) In the [Indoor unit electricity meter] section, select the electricity meter to be used to measure the electricity consumption of each group of indoor units.

In the pulldown menu, ["Address"+ PI controller address + "-" + meter number + meter name] will appear.

Note: If the group name is long, only part of it may be displayed.

Note: If the group name has not been registered, ["Group" + group number] will appear.

Note: Only the electricity meters whose measurement unit setting is set to [kWh] on the Measurement screen are available for selection.

(4) Click [Save Settings] to send the settings to the EB-50.

# 6. Functions 2

## 6-1. Set Temperature Range Limit

The settable temperature range for the local remote controllers or the Web Browser for User can be limited. By restricting the lower and upper limit of the set temperatures for cooling, heating, and auto modes, energy consumption can be reduced.

Click [Functions 2] in the menu bar, and then click [Set Temperature Range Limit] to access the set temperature range restrictions settings screen.

Note: Only the lower limit for the cooling mode and upper limit for the heating mode can be set for the ME remote controller (PAR-F27MEA-E).

Note: The set temperature range restrictions settings may not be effective, depending on the unit model of the remote controller and the indoor unit.

Note: A-control (Mr. Slim) units do not support the set temperature range restrictions settings.

Note: The set temperature range restrictions settings will be effective on the Web Browser for User, but not on the Web Browser for System Maintenance Engineer. The temperature can be set to any temperature within the unit's operable temperature range on the Web Browser for System Maintenance Engineer regardless of the set temperature range restrictions settings.

Note: The set temperature range restrictions settings may not be accessible if logged in as a building manager.

Note: The set temperature limit range for the AUTO mode cannot be set for the groups that support the dual set point function in the AUTO mode. The set temperature ranges for the normal cooling and heating modes will be used for the ones for cooling and heating in the Auto (dual set point) mode.

Group No.	Group Name	Cooling Mode	Heating Mode	Auto Mode	Batch Operations
1	Entrance	24 - 28 °C	- °C	- °C	Copy Paste
2	Lobby(South)	26 - 28 °C	20 - 23 °C	- °C	Copy Paste
3	Lobby(East)	26 - 28 °C	20 - 23 °C	- °C	Copy Paste
4	Lobby(Center)	26 - 28 °C	20 - 23 °C	- °C	Copy Paste
5	Lobby(West)	26 - 28 °C	20 - 23 °C	- °C	Copy Paste
6	Meeting room A	- °C	- °C	19 - 23 °C	Copy Paste
7	Meeting room B	24 - 28 °C	- °C	- °C	Copy Paste

- Scroll up or down to display the group whose settings are to be made. To make settings for all groups at once, click [Batch Operations].

Then, click the [Set temperature range] area to display the setting screen.

Set the temperature ranges for cooling, heating, and auto modes.

Click [OK] to return to the previous screen.

Note: When the temperature unit is Fahrenheit, temperatures are displayed in 2°F increments.

Note: The temperature range for Dry mode will be the same as the one for cooling mode.

- To copy the settings of a group to the settings for other groups, click [Copy] in the row of the group whose settings are to be copied, then click [Paste] in the row of the group to which the copied settings are to be pasted. The rectangular icons next to the selected buttons will appear in yellow-green.

(3) Click [Save Settings] to send the settings to the EB-50.

## 6-2. Night Mode (quiet operation) Schedule

Outdoor units can be operated in a quiet mode for the specified time period. Use the Night mode when low-noise operation of the outdoor unit is preferable during the night.

Click [Functions 2] in the menu bar, and then click [Night Mode Schedule] to access the Night Mode Schedule settings screen.

Note: Make the Night Mode Schedule settings only when all the units are in normal operation. When connection error occurs with the indoor or the outdoor units, the target outdoor units may not be displayed properly.

Note: The degree of noise reduction depends on the outdoor unit model.

Note: The Night Mode Schedule settings may not be accessible if logged in as a building manager.

**Start Time**

**End Time**

**Target Outdoor Units**

**Refresh**  
Click to import the settings from EB-50.

**Save Settings**  
Click to send the settings to EB-50.

- (1) In the [Start Time] and [End Time] sections, specify the start and end times for the Night mode.  
Note: When the start time and the end time is the same, the units will operate in the Night mode at all times.
- (2) In the [Target Outdoor Units] section, select the M-NET addresses of the target outdoor units.
- (3) Click [Save Settings] to send the settings to the EB-50.



### 6-3. System-changeover

The System-changeover function switches the operation modes of the indoor units connected to the same outdoor unit between cooling and heating based on the room temperature and the set temperature. Click [Functions 2] in the menu bar, and then click [System-changeover] to access the System-changeover settings screen.

The System-changeover function is available only on the Y series of outdoor units, whose operation modes do not include the Auto mode. Use this function to operate the air conditioning units in the heating mode in the morning and in the cooling mode in the afternoon. The operation mode of all indoor units will automatically be switched, eliminating the need to switch the operation mode manually from the remote controllers.

Note: Because the operation mode is selected based on the demands of the representative group or of the majority of the groups, not all areas may be air conditioned to the optimum temperature.

Note: The System-changeover settings may not be accessible if logged in as a building manager.

Note: If the outdoor unit is an R2 series, whose operation modes include the Auto mode, use the Auto mode instead of the System-changeover function to switch the operation mode automatically.

**Target outdoor unit**  
The M-NET address of the outdoor unit appears.

**Change Mode**

**Refresh**  
Click to import the settings from EB-50.

**Groups**  
The names of the groups that are connected to the outdoor unit appear. When the [Representative Group] mode is selected, select the representative group from among these groups.

**Save Settings**  
Click to send the settings to EB-50.

- (1) Select the Change Mode [None], [Averaging], or [Representative Group], referring to the table below. If [Representative Group] is selected, also select a representative group from among the groups on the right.

Table 6-1 Change Mode

Change Mode	Content
None	System-changeover function will not be used.
Averaging	The operation mode (cooling or heating) will be switched based on the demands of the majority of all groups connected to the outdoor unit, taking into consideration the capacity of each indoor unit and the temperature differences between the set temperatures and room temperatures.
Representative Group	The operation mode (cooling or heating) will be switched based on the temperature difference between the set temperature and the room temperature of the representative group.

- (2) Click [Save Settings] to send the settings to the EB-50.

# 7. Functions 3

## 7-1. External Temperature Interlock

Based on the temperature difference between the set temperature and the outdoor temperature, the set temperature can be adjusted automatically. Making this control setting on the air conditioning unit at an entrance of a building prevents extreme temperature change from distressing our bodies and sending us into shock. Click [Functions 3] in the menu bar, and then click [External Temperature Interlock] to access the External Temperature Interlock settings screen.

Note: AI controller (PAC-YG63MCA) is required to measure the outdoor temperature.

Note: This function is activated only when the operation mode is Cool or Dry.

Note: The External Temperature Interlock settings may not be accessible if logged in as a building manager.

**Temperature Sensor**  
Select a temperature sensor to measure the outdoor temperature with.

**Group No. and group name**

Group No.	Group Name	Set Temperature Variation Range
1	Entrance	None   +1°C   +2°C   +3°C   +4°C
2	Lobby(South)	None   +1°C   +2°C   +3°C   +4°C
3	Lobby(East)	None   +1°C   +2°C   +3°C   +4°C
4	Lobby(Center)	None   +1°C   +2°C   +3°C   +4°C
5	Lobby(West)	None   +1°C   +2°C   +3°C   +4°C

**Set Temperature Variation Range**  
Select a maximum temperature value to be added to the set temperature.

**Refresh**  
Click to import the settings from EB-50.

**Save Settings**  
Click to send the settings to EB-50.

- (1) In the [Temperature Sensor] section, select a temperature sensor to measure the outdoor temperature with. In the pulldown menu, the name of the temperature sensor that is connected to the AI controller or the AHC will appear.

Note: Connect the temperature sensor to either the Analog Input 1 or Analog Input 2 port on the AHC.

- (2) In the [Set Temperature Variation Range] section, select a maximum temperature value for each group to be added to the set temperature. For example, when [+4°C] (+8°F) is selected and the set temperature is 24°C (75°F), the set temperature will be adjusted to maximum of 28°C (83°F) based on the temperature difference between the set temperature and the outdoor temperature. When [+2°C] (+4°F) is selected, the set temperature will be adjusted to maximum of 26°C (79°F).

Note: When the unit of temperature is Fahrenheit, the selected temperature value may not be added to the set temperature accurately because 2°C is used for the calculation first, and then the temperature in Celsius is converted into the temperature in Fahrenheit.

- (3) Click [Save Settings] to send the settings to the EB-50.

When the External Temperature Interlock function is active, the set temperature will be adjusted as shown below.

■ "Cool" and "Dry" modes

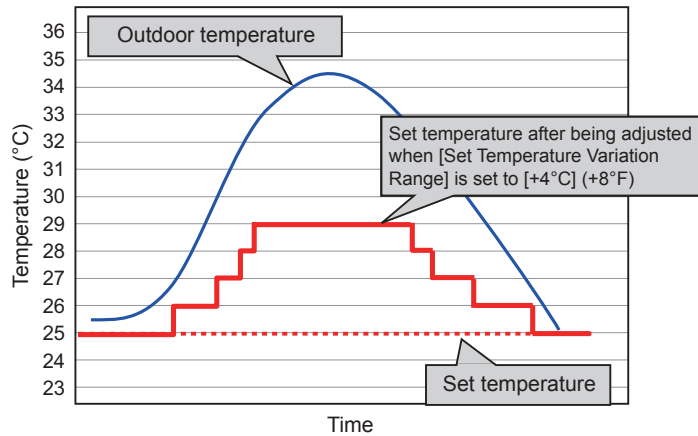

Outdoor temperature conditions	Set temperature after being adjusted
Outdoor temperature $\geq$ Set temperature + 1.5°C (2.7°F)	Set temperature + 1°C (2°F)
Outdoor temperature $\geq$ Set temperature + 4.5°C (8.1°F)	Set temperature + 2°C (4°F)
Outdoor temperature $\geq$ Set temperature + 6.5°C (11.7°F)	Set temperature + 3°C (6°F)
Outdoor temperature $\geq$ Set temperature + 7.5°C (13.5°F)	Set temperature + 4°C (8°F)

■ "Heat" mode

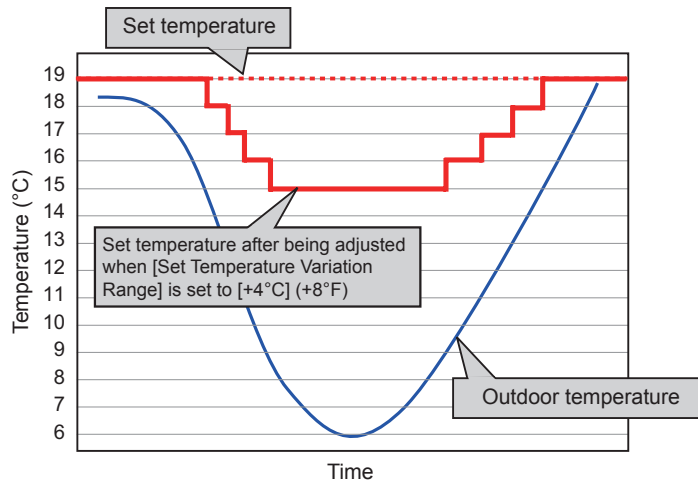

Outdoor temperature conditions	Set temperature after being adjusted
Outdoor temperature $\leq$ Set temperature - 4.0°C (7.2°F)	Set temperature - 1°C (2°F)
Outdoor temperature $\leq$ Set temperature - 6.0°C (10.8°F)	Set temperature - 2°C (4°F)
Outdoor temperature $\leq$ Set temperature - 8.0°C (14.4°F)	Set temperature - 3°C (6°F)
Outdoor temperature $\leq$ Set temperature - 10.0°C (18.0°F)	Set temperature - 4°C (8°F)

## 7-2. Night Setback Control

The Night Setback Control function (hereafter abbreviated as Setback Control) prevents indoor condensation by performing heating operation automatically when the room temperature goes outside of the specific range during the night. Click [Functions 3] in the menu bar, and then click [Night Setback Control] to access the Night Setback Control settings screen.

Heating operation starts when a given group is stopped and the room temperature drops below the specified minimum temperature.

Note: The Setback Control function also prevents excessive temperature rise by performing cooling operation automatically when the room temperature goes outside of the specific range. Cooling operation starts when a given group is stopped and the room temperature rises above the specified maximum temperature.

Note: If the room temperature is measured by the return air temperature sensor on the air conditioning unit, the measured value may not be an accurate representation of the temperature in the room, especially when the air conditioning unit is stopped and the room air is stagnant. When this is the case, use an external temperature sensor (PAC-SE40TSA) or remote controller sensor to measure the room temperature.

Note: The Night Setback Control may not be accessible if logged in as a building manager.

**Setback Control Usability** → [Use]

**Setback Control Period** → [01:00 - 05:00]

**Temperature range** → [12°C - 28°C]

**Group No. and group name** → [1 Entrance]

**Copy** → [Copy]

**Paste** → [Paste]

**Refresh** → [Refresh]

**Save Settings** → [Save Settings]

Click to import the settings from EB-50.

Click to send the settings to EB-50.

Group No.	Group Name	Minimum Temp	Maximum Temp	Copy	Paste
1	Entrance	12°C	28°C	Copy	Paste
2	Lobby(South)	12°C	28°C	Copy	Paste
3	Lobby(East)	12°C	28°C	Copy	Paste
4	Lobby(Center)	12°C	28°C	Copy	Paste
5	Lobby(West)	12°C	28°C	Copy	Paste

(1) Select [Use] and set the time period in which Setback Control is performed.

Note: When [00:00 - 00:00] is selected, Setback Control is active for 24 hours.

(2) In the [Temperature range] section, set the maximum and minimum temperatures for each group.

For example, if [Setback Control Period] is set to [01:00 - 05:00] and [Temperature range] is set to [12°C - 28°C] ([53.6°F - 82.4°F]), heating operation starts automatically when the room temperature drops below the set temperature 12°C (53°F) between 1:00 and 5:00. When the Setback Control ends at 5:00, the set temperature returns to the original setting, and the operation stops.

Note: The air conditioning units in the heating operation will stop and the set temperature will return to the original setting when the Setback Control period is over or the room temperature rises to the minimum temperature plus 3°C (5.4°F). Likewise, the air conditioning units in the cooling operation will stop and the set temperature will return to the original setting when the Setback Control period is over or the room temperature drops to the maximum temperature minus 3°C (5.4°F).

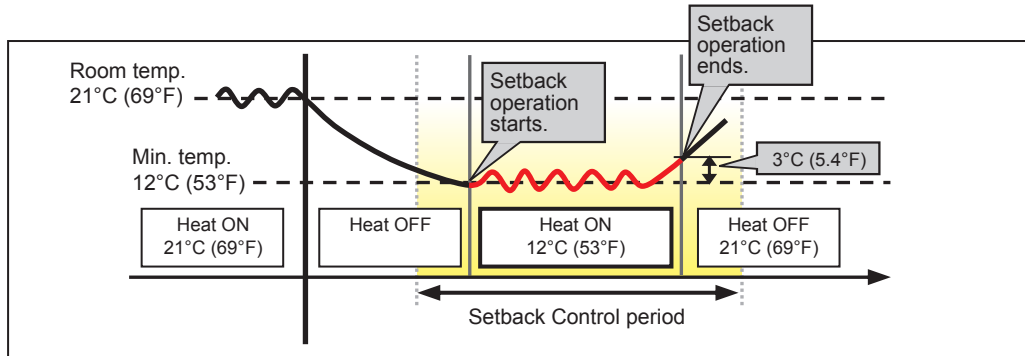

When the temperature drops below the minimum temperature (heating operation)

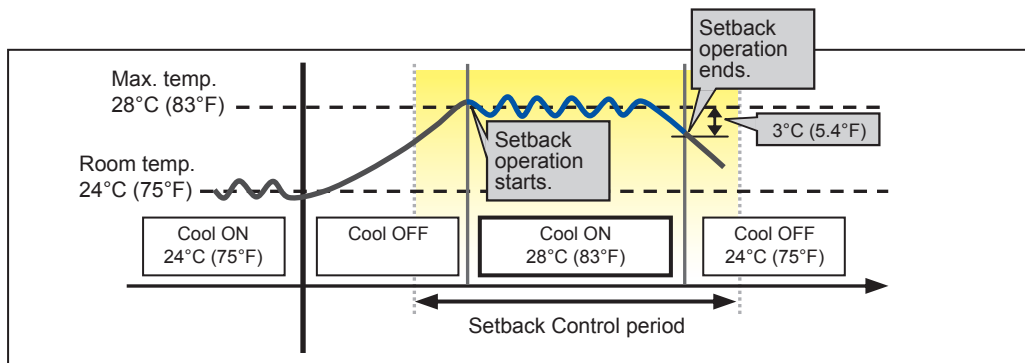

When the temperature rises above the maximum temperature (cooling operation)

- (3) To copy the settings of a group to the settings for other groups, click [Copy] in the row of the group whose settings are to be copied, then click [Paste] in the row of the group to which the copied settings are to be pasted. The rectangular icons next to the selected buttons will appear in yellow-green.
- (4) Click [Save Settings] to send the settings to the EB-50.

## 7-3. Interlock control

Click [Functions 3] in the menu bar, and then click [Interlock control] to access the Interlock Control settings screen. Set the interlocking conditions and actions, and then click [Save Settings] to send the settings to the EB-50.

Note: A separate license is required to use the Interlock Control function. Make sure that the required license has properly been registered on the Registration of Optional Functions screen. (Refer to chapter 10 for details.)

Note: The Interlock Control settings may not be accessible if logged in as a building manager.

Note: Interlock Control is not effective when [External Input Setting] is set to [ON/OFF (Level signal)]. (See section 4-2-3).

Note: If a group is deleted on the group settings screen, be sure to delete the Interlock Control settings in which the group is selected as the input units or the output units.

The screenshot shows the 'Interlock control' settings screen in a web browser. The interface includes a top navigation bar with 'Functions 3' selected. The main area is divided into 'Input Category' and 'Output Unit Type' sections. The 'Input Category' section has 'Input State' set to 'Cool' and 'Select Input Units' with three groups listed. The 'Output Unit Type' section has 'Action' set to 'ON Dry' and 'Select Output Units' with four groups listed. A status bar at the bottom shows '79°F' and 'Mode'. A scroll bar is visible on the right side of the main content area. A footer contains 'Copyright © 2004-2013 MITSUBISHI ELECTRIC CORPORATION'.

**Execute/Stop Execution**  
Click to enable/disable the Interlock Control.

**Enable/Disable**  
Click to enable/disable each Interlock Control setting.

**Input Category**

**Input state 1**

**Input state 2**

**Select Input Units**  
Click to display the screen to select input units.

**Refresh**  
Click to import the settings from EB-50.

**Save Settings**  
Click to send the settings to EB-50.

**Delete all steps**  
Click to delete all Interlock Control settings.

**Output Unit Type**

**Edit buttons**

**Status bar**  
Shows the settings status of 150 settings (Green: Settings have been made; Red: Incomplete settings exist.)

**Scroll bar**  
Slide to show different Interlock Control settings between No.1 and No.150.

**Action**  
Click to set the interlocking actions.

**Select Output Units**  
Click to display the screen to select output units.

Up to 150 Interlock Control settings from No.1 through No.150 can be set. The Interlock Control verifies the state changes in an ascending order of No.1 to No.150 every three to five seconds. When the interlocking conditions are met, the interlocking action commands will be issued to the output units.

By making the interlocking condition settings (input category, input states, and input units) and interlocking action settings (output unit type, actions, and output units) for each Interlock Control setting, the operation of the output units can be interlocked with the operation of the input units.

### Caution:

Before using the Interlock Control function, you must agree to the following.

1. This function must not be used for disaster prevention or security purposes unless a backup device is provided in case of failure of this function. (This function should never be used in the way that would put people's lives at risk.)
2. The interlocking action settings that are not supported by the interlocked output units must not be made on the [Set up Actions] screen. Failure to observe this precaution may result in malfunctions.
3. After completing each Interlock Control setting, perform a test run and confirm proper settings and operation.
4. Do not set the Interlock Control settings as the following examples show. Doing so will cause short-cycling, resulting in unit damage.

Example 1: Group 1 is turned off when Group 1 is turned on.

Example 2: Group 1 is turned on when Group 1 is turned off.

Shown below are four examples of Interlocked operations.

Example 1: Interlocked operation of indoor unit and card key via a DIDO controller

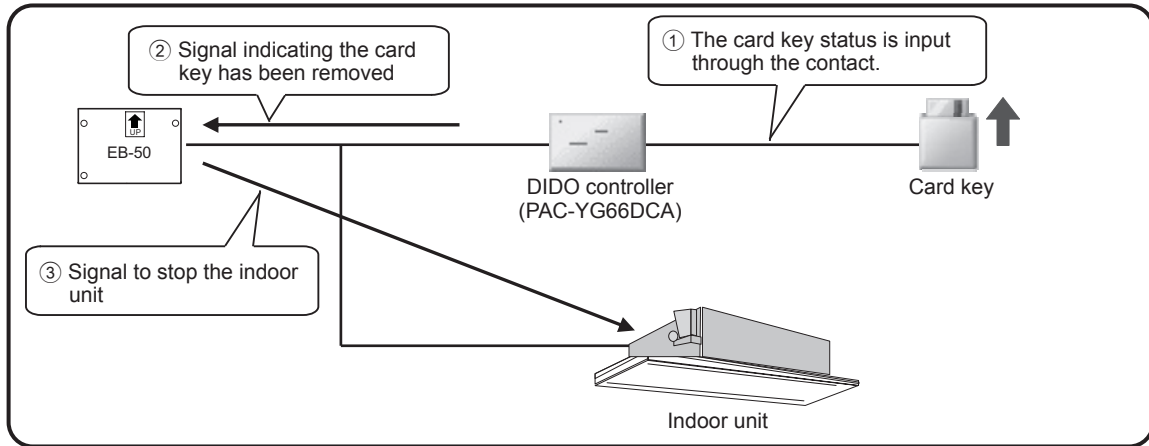

Example 2: Interlocked operation of operation mode between indoor units

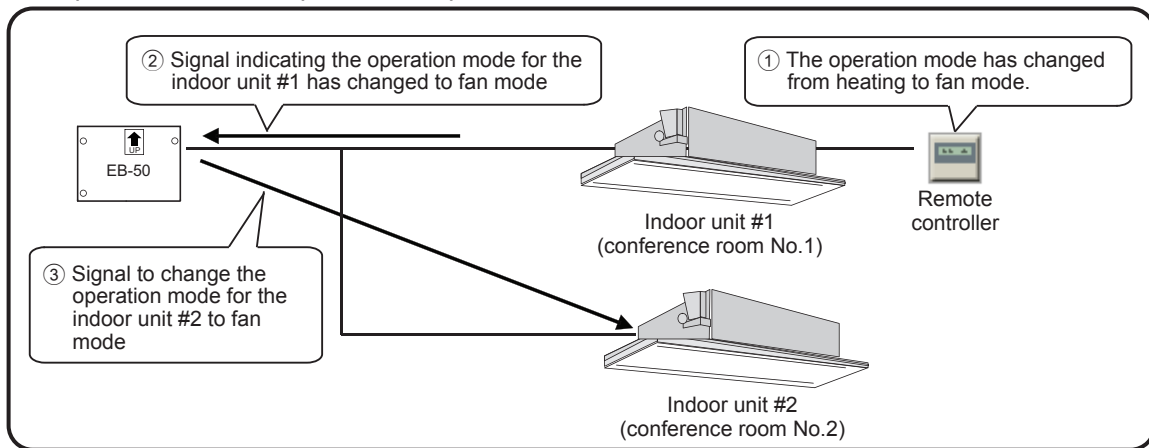

Example 3: Interlocked operation of indoor unit and window through the free contact on an indoor unit

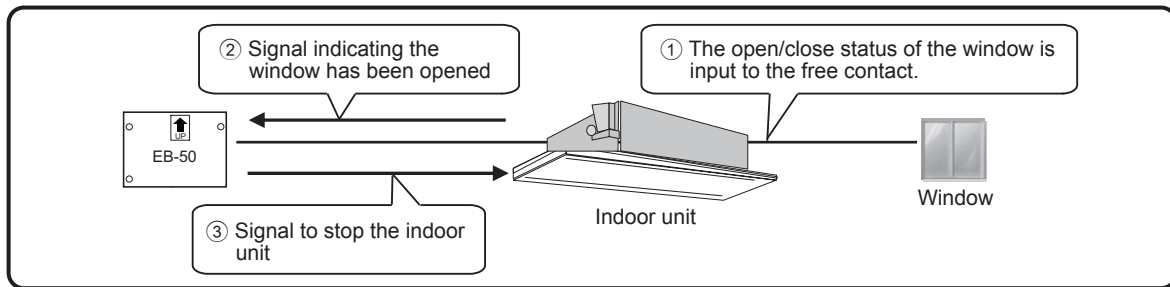

Example 4: Interlocked operation of indoor unit, lighting, and card key through the free contact on an indoor unit

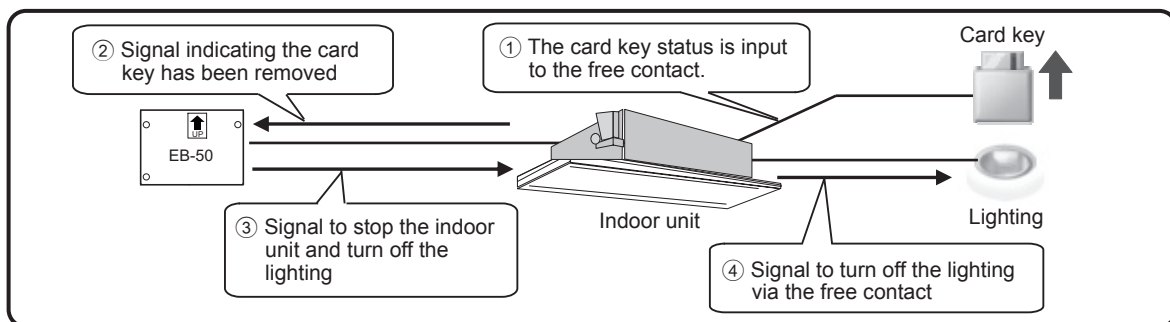





### 7-3-1. Making the interlocking condition settings

(1) Setting an Input Category and Input States

Select an Input Category and Input States 1 and 2, referring to the table below.

Table 7-1 Interlocking condition settings

Input Category	Input unit icon	Input State 1	Input State 2
Group (On/Off)		All Groups On All Groups Off One or more Groups On One or more Groups Off	–
Group (Mode)		All groups in the mode All groups out of the mode One or more groups in the mode One or more groups out of the mode	Air conditioning unit group: *1 *2 *3 Cool, Dry, Fan, Heat, Auto, Setback LOSSNAY unit group: Bypass, Heat Recovery, Auto
Group (Error/Normal)		All units in error All units in normal operation One or more units in error One or more units in normal operation	–
Free Input Points (On/Off)		All Units On All Units Off One or more Units On One or more Units Off	–

\*1 The operation modes for Air To Water (PWFY) unit groups are not available for selection.

\*2 If the selected operation mode is not available on the input unit, interlocking conditions will not be fulfilled.

\*3 The Setback mode can be selected on the EB-50GU-A, but not on the EB-50GU-J.

Note: If the Input Category is set to [Group (On/Off)] and the Input State 1 is set to [All Groups On], the interlocking action commands will be issued to the output units when the state on the input units changes to [All Groups On] from another state [All Groups Off], [One or more Groups On], or [One or more Groups Off].

Note: Free contact is available for use on R410A- and R407C-compatible indoor units with software Ver. 33 or later. The software version can be confirmed with the Maintenance Tool.

Note: When [External Input Setting] is set to [Emergency Stop (Level signal)] (see section 4-2-3) or when the indoor unit is stopped due to the Peak Cut control (see section 5-2), only the Interlock Control of free contact and DIDO controller (PAC-YG66DCA) will be performed, but other Interlock Control will not be.



(2) Selecting the input units

Click [Select Input Units] to display one of the following screens, depending on the selected Input Category.

(A) When [Group (On/Off)], [Group (Mode)], or [Group (Error/Normal)] is selected as the Input Category

The [Select Input Groups] screen will appear.

Select the group numbers of the input unit groups. The selected group numbers will appear with a yellow-green background.

Click again to deselect. The deselected group numbers will appear with a light-gray background.

To deselect all selected groups, click [Reset selections].

To select a block of groups, click [Select a Block]. Select a block name and press [OK]. The groups that are registered to the block will appear with a yellow-green background.

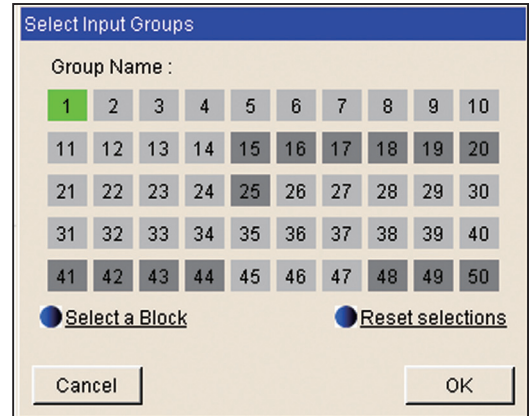

Note: If the Input Category is set to [Group (On/Off)] or [Group (Error/Normal)], air conditioning unit groups, LOSSNAY unit groups, Air To Water (PWFY) unit groups, and general equipment (connected via DIDO controller PAC-YG66DCA) groups can be selected.

If the input category is set to [Group (Mode)], air conditioning unit groups and LOSSNAY unit groups can be selected.

Note: Different types of groups (air conditioning unit groups, LOSSNAY unit groups, or general equipment (connected via DIDO controller PAC-YG66DCA) groups) cannot be simultaneously selected.

(B) When [Free Input Points (On/Off)] is selected as the Input Category

The [Select Addresses of Input Units] screen will appear.

Select the addresses of the indoor units to which the general equipment is connected, and select contact points for each indoor unit.

The selected unit address will appear with a red frame.

The unit addresses whose contact points have been set will appear with a yellow-green background.

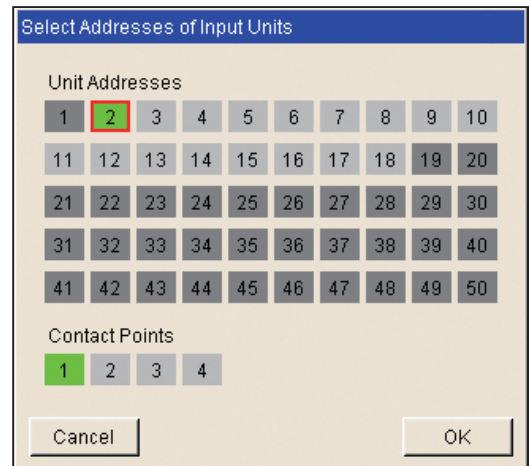



## 7-3-2. Making the interlocking action settings

### (1) Setting an Output Unit Type and Actions

Select an Output Unit Type and set the Actions, referring to the table below.

Table 7-2 Interlocking action settings

Output Unit Type	Output unit icon	Actions	
		Setting item	Setting options
Group		ON/OFF	ON, OFF
		Mode *1 *2	Air conditioning unit group: *3 Cool, Dry, Fan, Heat, Auto, Setback LOSSNAY unit group: Bypass, Heat Recovery, Auto
		Set Temp. *1 *4	Desired temperature
		Air direction *1	Mid3, Mid2, Mid1, Mid0, Horizontal, Swing, Auto
		Fan speed *1	Low, Mid2, Mid1, High, Auto
		Prohibit Remote Controller Operation (ON/OFF)	Permit, Prohibit
		Prohibit Remote Controller Operation (Mode)	Permit, Prohibit
		Prohibit Remote Controller Operation (Set Temp.)	Permit, Prohibit
Free Output Points		ON/OFF	ON, OFF

\*1 The available setting options vary, depending on the connected indoor unit model.

Make the interlocking action settings that are available for the output units.

\*2 The operation modes for Air To Water (PWFY) unit are not available for selection.

\*3 The Setback mode can be selected on the EB-50GU-A, but not on the EB-50GU-J.

\*4 The set temperature for Air To Water (PWFY) unit cannot be set.

The screen display under Action will vary, depending on the selected Output Unit Type.

(A) When [Group] is selected as the Output Unit Type

Click [Edit] under Action. The [Set up Actions] screen will appear.

Set the interlocking actions to be taken when the interlocking conditions are met.

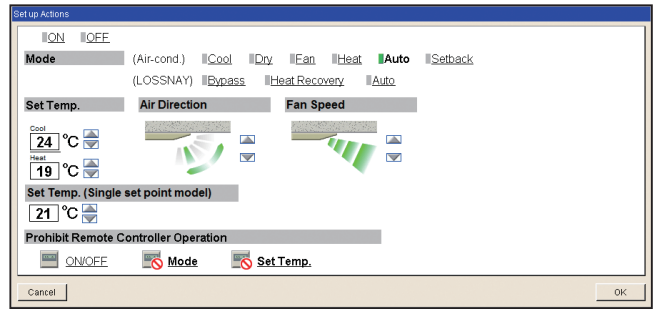

Note: The current operation status will be maintained for the setting items that were not changed.

Note: The set temperature cannot be set unless the operation mode has been set.

Note: If the selected operation mode is not available on the interlocked output units, the Interlock Control will not be performed.

Note: To prevent malfunctions of the air conditioning units, be sure to set the set temperature to a temperature within the normal operating temperature range, although there may be rare cases in which it is possible to set the set temperature to a temperature outside the normal operating temperature range (depending on the model of the air conditioning units that are connected to a system).

Note: Signals for Swing and Auto of Air direction setting and Auto of Fan speed setting will not be output unless these functions are available on the interlocked output units.

With respect to the air direction and fan speed, if the number of settable air directions and fan speeds vary among the connected unit models, the signals that are rounded up to the settable range may be output.

Note: When the interlocking conditions are met, it will take some time to issue the interlocking action commands to the output units. This may delay the state change verification, which is usually performed every three to five seconds.

(B) When [Free Output Points] is selected as the Output Unit Type

Select [ON] or [OFF] under Action to turn on or off the output units.

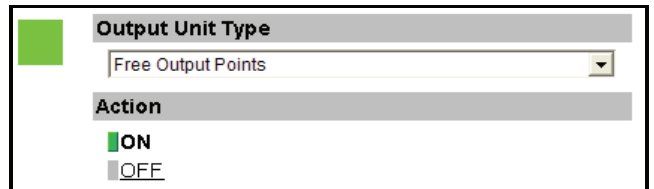

(2) Selecting the output units

Click [Select Output Units] to display one of the following screens, depending on the selected Output Unit Type.

(A) When [Group] is selected as the Output Unit Type

The [Select Output Groups] screen will appear.

Select the group numbers of the output unit groups. The selected group numbers will appear with a yellow-green background.

Click again to deselect. The deselected group numbers will appear with a light-gray background.

To deselect all selected groups, click [Reset selections].

To select a block of groups, click [Select a Block]. Select a block name and press [OK]. The groups that are registered to the block will appear with a yellow-green background.

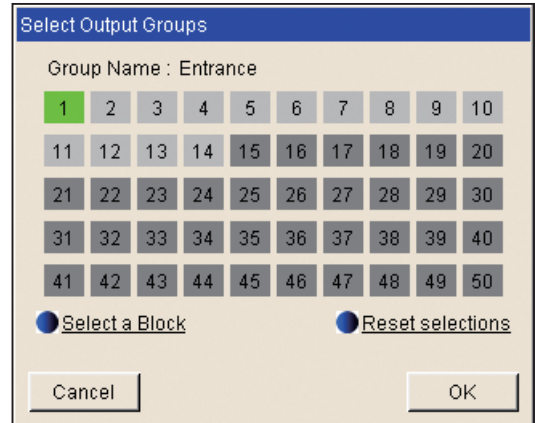

Note: If the Output Unit Type is set to [Group], air conditioning unit groups, LOSSNAY unit groups, Air To Water (PWFY) unit groups, and general equipment (connected via DIDO controller PAC-YG66DCA) groups are available for selection.

Note: Different types of groups (air conditioning unit groups, LOSSNAY unit groups, Air To Water (PWFY) unit groups, or general equipment (connected via DIDO controller PAC-YG66DCA) groups) cannot be simultaneously selected.

(B) When [Free Output Points] is selected as the Output Unit Type

The [Select Addresses of Output Units] screen will appear.

Select the addresses of the indoor units to which the general equipment is connected, and select contact points for each indoor unit.

The selected unit address will appear with a red frame.

The unit addresses whose contact points have been set will appear with a yellow-green background.

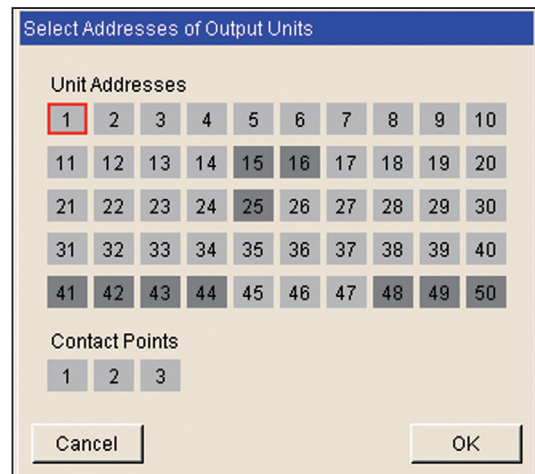

### 7-3-3. Disabling/Enabling Interlock Control settings

Use the Enable/Disable button to enable or disable each Interlock Control setting.  
No actions will be taken for the Interlock Control setting that is set to [Disable].

### 7-3-4. Temporarily disabling the Interlock Control

Click the [Stop Execution] button to temporarily disable the Interlock Control. Click [Execute] to resume the Interlock Control.

Note: State change that occurs while [Stop Execution] is selected will be ignored.

### 7-3-5. Editing Interlock Control settings

Use the Edit buttons to edit each row of Interlock Control setting.

Button name	Function
Delete all steps	Deletes all Interlock Control settings.
Insert a step	Inserts a blank row of Interlock Control setting above the row that is displayed, and moves all rows down by one. If interlocking conditions are entered in the last row, no more rows can be inserted.
Delete a step	Deletes the row of Interlock Control setting that is displayed, and moves up the rows below by one.
Clear the display	Clears the row of Interlock Control setting that is displayed.
Copy	To copy the settings of a row to the settings for other rows, display the row whose settings are to be copied and click [Copy], then display the row to which the copied settings are to be pasted and click [Paste].
Paste	

## 7-4. AHC Port Name Settings

On the AHC Port Name Settings screen, enter the names of the input and output ports of the Advanced HVAC CONTROLLER (AHC).

The names that are entered on this screen will appear on the AHC List screen, accessible via the Web Browser for System Maintenance Engineer.

Click [Functions 3] in the menu bar, and then click [AHC Port Name Settings] to access the AHC Port Name Settings screen.

Note: The AHC port name settings may not be accessible if logged in as a building manager.

Important: The AHC port name settings must be made after all units have been started up.  
The settings that have been saved while one or more units are starting up may be lost.

The screenshot shows the 'AHC Port Name Settings' web page. The interface is divided into three main columns: 'Input Name', 'Output Name', and 'Unit address'. The 'Input Name' column contains a list of digital inputs (DI1-DI15) and extended inputs (EI1-EI4). The 'Output Name' column contains a list of digital outputs (DO1-DO9), extended outputs (EO1-EO4), and analog outputs (AO1-AO2). The 'Unit address' column shows a list of unit addresses (201-204). Annotations point to various elements: 'Unit address' points to the left column; 'Digital Input (1-15)' points to the DI list; 'Input Port Name' points to the 'Input Name' header; 'Refresh' points to a 'Refresh' button at the bottom; 'Extended Input (1-4)' points to the EI list; 'Output Port Name' points to the 'Output Name' header; 'Digital Output (1-9)' points to the DO list; 'Extended Output (1-4)' points to the EO list; 'Analog Output (1-2)' points to the AO list; 'Analog Input (1-8)' points to the AI list; and 'Save Settings' points to a 'Save Settings' button at the bottom. A note at the bottom right says 'Click to send the settings to EB-50.'

(1) In the [Input Port Name] field, enter the input port name in 20 characters or less.

Note: Digital Input (DI) 1–15, Extended Input (EI) 1–4, and Analog Input (AI) 1–8 will appear regardless of whether the ports are used or not.

Note: The following characters cannot be used in the [Input Port Name] field: <, >, +, &, ", or '

(2) In the [Output Port Name] field, enter the output port name in 20 characters or less.

Note: Digital Output (DO) 1–9, Extended Output (EO) 1–4, and Analog Output (AO) 1–2 will appear regardless of whether the ports are used or not.

Note: The following characters cannot be used in the [Output Port Name] field: <, >, +, &, ", or '

(3) Click [Save Settings] to send the settings to the EB-50.

# 8. User Settings

On the User Settings screen, the user names and passwords of maintenance users and building managers can be changed, and the available functions for building managers can be limited.

For example, you can allow building managers to change the group name settings when the tenant is changed, or disallow them to change the basic system settings such as unit settings or network settings.

Also, maintenance users can use this screen to change the user name and password of building managers in case that they are forgotten.

Click [User Settings] in the menu bar to access the User Settings screen.

**Maintenance user name and password**  
User name and password can be changed.

**Building manager's user name and password**  
User name and password can be changed.

**Available functions**  
Select the available functions for building managers.

**Refresh**  
Click to import the settings from EB-50.

**Save Settings**  
Click to send the settings to EB-50.

- (1) To change the maintenance user name or password, type new information in the [User Name], [New Password], and [Retye Password] fields.
  - Note: If the user logs in as a building manager, the maintenance user name and the password will not be displayed, and cannot be changed.
  - Note: User name must contain only alphanumeric characters.
  - Note: The user name and password are case-sensitive.
- (2) To change the building manager's user name or password, type new information in the [User Name], [New Password], and [Retye Password] fields.

- (3) Click the functions to be made available for building managers. The rectangular icons next to the selected functions will appear in yellow-green. Click again to deselect. The rectangular icons next to the deselected functions will appear in gray. For more information on each function, refer to Table 8-1.

Note: If the user logs in as a building manager, the currently available functions can be checked, but cannot be changed.

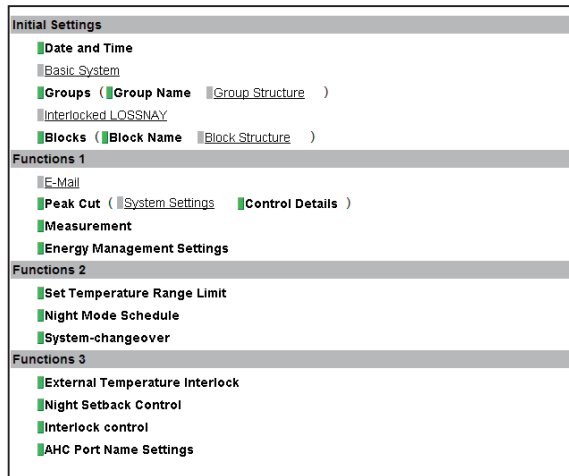

Table 8-1 Available Function List

Function		Content	
Initial Settings	Date and Time	Refer to section 4-1 for details.	
	Basic System *1	Refer to section 4-2 for details.	
	Groups	Group Name	Refer to section 4-3 for details.
		Group Structure	
	Interlocked LOSSNAY *1	Refer to section 4-4 for details.	
Blocks	Block Name	Refer to section 4-5 for details.	
	Block Structure *1		
Functions 1	E-Mail *1	Refer to section 5-1 for details.	
	Peak Cut	System Settings	Refer to section 5-2 for details.
		Control Details	
	Measurement	Refer to section 5-3 for details.	
Energy Management Settings	Refer to section 5-4 for details.		
Functions 2	Set Temperature Range Limit	Refer to section 6-1 for details.	
	Night Mode Schedule	Refer to section 6-2 for details.	
	System-changeover	Refer to section 6-3 for details.	
Functions 3	External Temperature Interlock	Refer to section 7-1 for details.	
	Night Setback Control	Refer to section 7-2 for details.	
	Interlock control	Refer to section 7-3 for details.	
	AHC Port Name Settings	Refer to section 7-4 for details.	

\*1 At factory shipment, these settings by the building managers are prohibited.

- (4) Click [Save Settings] to send the settings to the EB-50.



# 9. Utility

## 9-1. Back up/import settings data

The following data can be exported to an HDD or a USB memory as a backup: the settings data that have been made from the Web Browser for Initial Settings, the schedule settings that have been made from the Web Browser for System Maintenance Engineer, and the target value settings of the energy management data. The exported data can be imported back to the EB-50 to restore the previous settings after EB-50 replacement. Click [Utility] in the menu bar, and then click [Back up/import settings data] to access the Back up/import settings data screen.

Note: Back up/import settings data function is accessible only if logged in as a maintenance user.

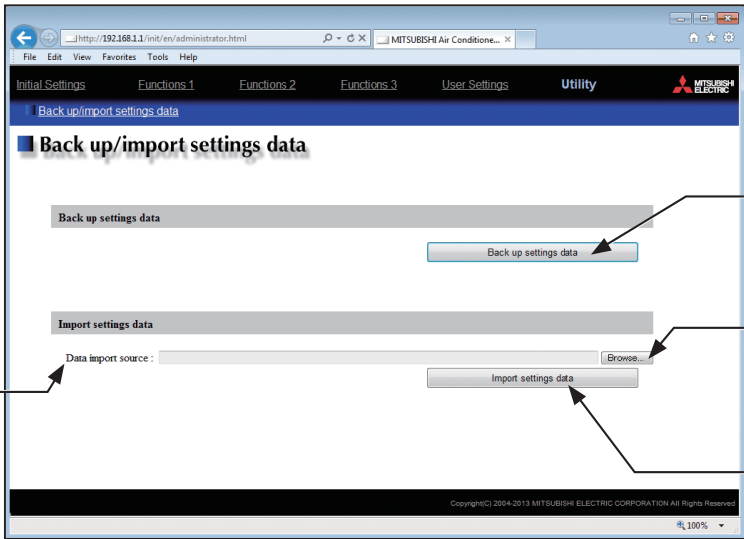

**Data import source**  
The path to the file to be imported will appear.

**Back up settings data**  
Click to back up the EB-50 settings data.

**Browse...**  
Click to browse for a file that contains the data to be imported.

**Import settings data**  
Click to import the file specified in the "Data import source" field to the EB-50.

### 9-1-1. Backing up settings data

- (1) To back up the data, click [Back up settings data]. The settings data will be created and the Window's standard file download dialog will appear.

Note: It will take a few minutes to create the settings data.

Note: The name of the settings data will be "SettingData.dat".



The first screenshot shows the message: "Creating settings data. Please wait".

The second screenshot shows the message: "Settings data have been created. Downloading data." with a [Back] button.

## 9-1-2. Importing settings data

- (1) Click the [Browse...] button to launch the explorer and browse for a file that contains the data to be imported. Select the desired file, and click [Open]. The path to the file to be imported on an external storage media will appear in the [Data import source] field.
- (2) Click [Import settings data] to import the data from the external storage media to the EB-50.  
Note: It will take a few minutes to import the settings data.

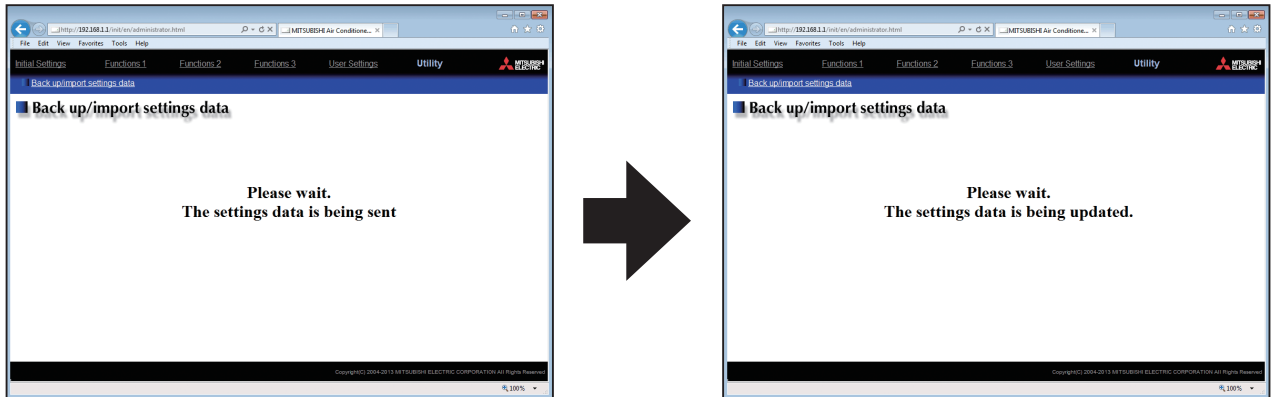

- (3) When the settings data has been successfully imported, the EB-50 will restart.

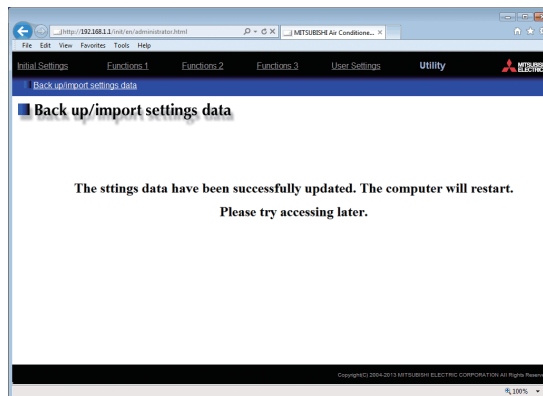

- (4) Go back to the login screen and login again.

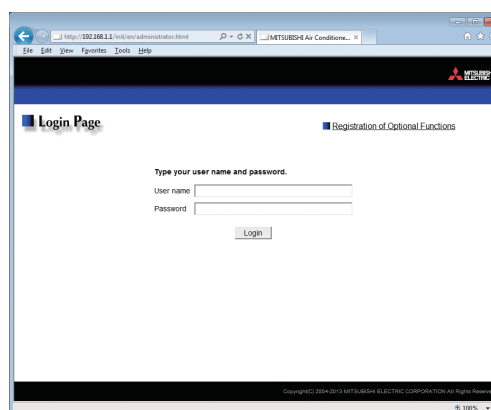

# 10. License registration for optional functions

This chapter explains how to register a license for optional functions.

Please ask your dealer for more details on the optional functions and how to purchase a license number.

Note: The current date and time settings are required for license registration. Refer to section 4-1 for date and time settings.

- (1) On the login screen, click [Registration of Optional Functions].

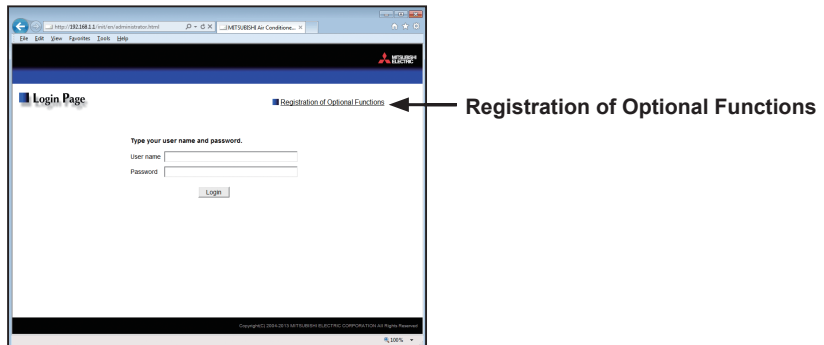

The [Registration of Optional Functions] screen will appear.

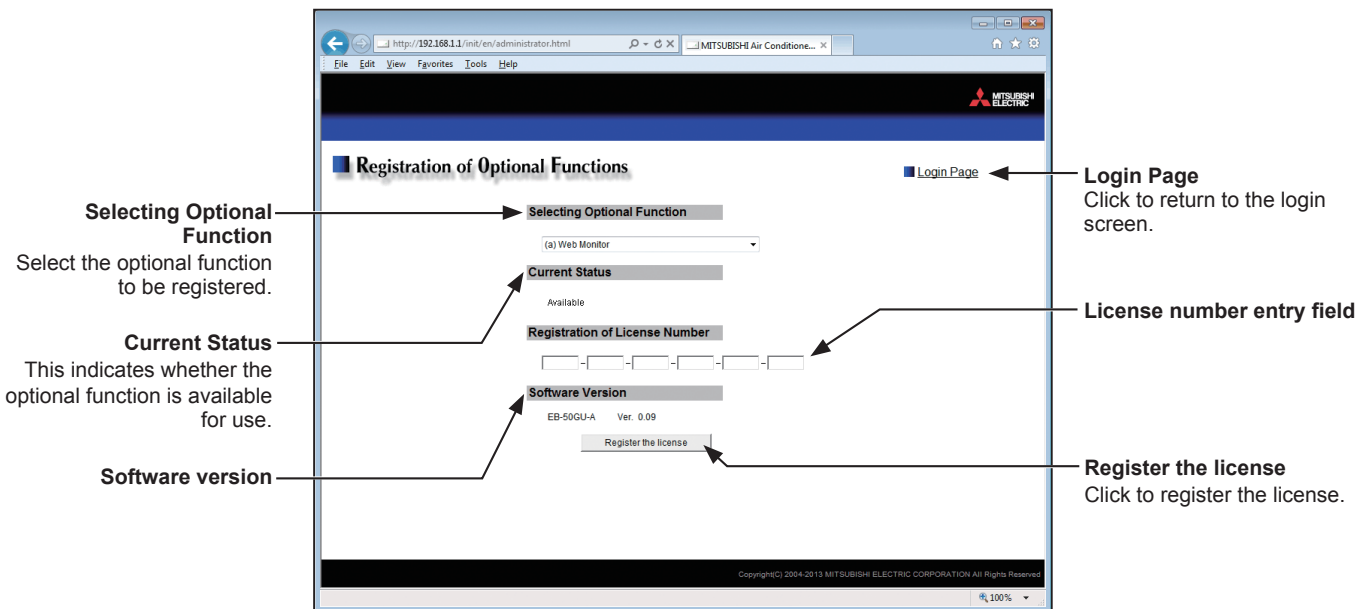

- (2) In the [Selecting Optional Function] section, select the optional function to be registered. The current availability will appear in the [Current Status] section.

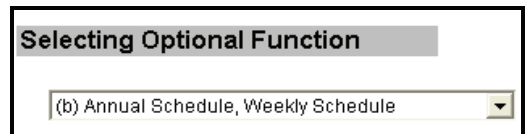

- (3) In the [License number entry] field, enter the license number and click [Register the license]. In the [Current Status] section, a word "Available" will appear. If the registration is unsuccessful, verify that the selected optional function and the license number are correct.

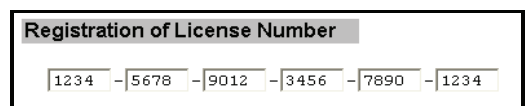

Note: Alphabet "O" and "I" are not used for license number.

---

This product is designed and intended for use in the residential,  
commercial and light-industrial environment.

The product at hand is based on the following EU regulations:

- Electromagnetic Compatibility Directive 2004/108/EC
- Restriction of Hazardous Substances 2011/65/EU

Please be sure to put the contact address/telephone number  
on this manual before handing it to the customer.

**MITSUBISHI ELECTRIC CORPORATION**

HEAD OFFICE: TOKYO BLDG., 2-7-3, MARUNOUCHI, CHIYODA-KU, TOKYO 100-8310, JAPAN