

**e-series
Air-cooled Chilling Unit**
EAHV/EACV
Installation/Operation Manual
**EAHV-P900YA(-H)(-N)(-BS)
EACV-P900YA(-N)(-BS)**
CONTENTS

Safety Precautions.....	2
1. Selecting the Installation Site.....	7
[1] Installation Conditions.....	7
[2] Installation Space Requirement.....	7
2. Unit Installation	12
[1] Product suspension method	12
[2] Center of gravity position	12
[3] Installation on foundation.....	13
[4] Add the refrigerant.....	14
3. Water Pipe Installation.....	17
[1] Schematic Piping Diagram and Piping System Components.....	17
[2] Water piping attachment method.....	18
[3] Notes on Pipe Corrosion.....	20
[4] Installing the Strainer and Flow Switch.....	22
[5] Ensuring enough water in the water circuit.....	23
[6] Water Piping Size and Location.....	24
4. System Configurations.....	25
[1] Schematic Diagrams of Individual and Multiple Module Connection Systems	25
[2] Switch Types and the Factory Settings	26
[3] Configuring the Settings	28
5. Electrical Wiring Installation.....	46
[1] Main Power Supply Wiring and Switch Capacity	46
[2] Cable Connections	47
6. Troubleshooting	55
[1] Diagnosing Problems for which No Error Codes Are Available.....	55
[2] Diagnosing Problems Using Error Codes	56
[3] Calling for Service.....	59
7. Operating the Unit.....	60
[1] Initial Operation.....	60
[2] Daily Operation	60
[3] Using the Unit in Sub-freezing	61
[4] Using the Remote Controller	62
[5] Function Settings.....	67
8. Main Specifications.....	69
[1] Model name	69
[2] Specifications.....	70
[3] Technical documentation of fan.....	73

Thoroughly read this manual prior to use.



Save this manual for future reference.

Some of the items in this manual may not apply to made-to-order units.

Make sure that this manual is passed on to the end users.

Safety Precautions

- Thoroughly read the following safety precautions prior to use.
- Observe these precautions carefully to ensure safety.

 WARNING	Indicates a risk of death or serious injury
 CAUTION	Indicates a risk of injury or structural damage
 IMPORTANT	Indicates a risk of damage to the unit or other components in the system

All electric work must be performed by personnel certified by Mitsubishi Electric.

General

WARNING

Do not use refrigerant other than the type indicated in the manuals provided with the unit and on the nameplate.

- Doing so may cause the unit or pipes to burst, or result in explosion or fire during use, during repair, or at the time of disposal of the unit.
- It may also be in violation of applicable laws.
- MITSUBISHI ELECTRIC CORPORATION cannot be held responsible for malfunctions or accidents resulting from the use of the wrong type of refrigerant.

Do not install the unit in a place where large amounts of oil, steam, organic solvents, or corrosive gases, such as sulfuric gas, are present or where acidic/alkaline solutions or sprays containing sulfur are used frequently.

These substances can compromise the performance of the unit or cause certain components of the unit to corrode, which can result in refrigerant leakage, water leakage, injury, electric shock, malfunctions, smoke, or fire.

Do not try to defeat the safety features of the unit or make unauthorized setting changes.

Forcing the unit to operate the unit by defeating the safety features of the devices such as the pressure switch or the temperature switch, making unauthorized changes to the switch settings, or using accessories other than the ones recommended by Mitsubishi Electric may result in smoke, fire, or explosion.

To reduce the risk of fire or explosion, do not use volatile or flammable substances as a heat carrier.

To reduce the risk of burns or electric shock, do not touch exposed pipes and wires.

To reduce the risk of shorting, current leakage, electric shock, malfunctions, smoke, or fire, do not splash water on electric parts.

To reduce the risk of electric shock, malfunctions, smoke or fire, do not operate the switches/buttons or touch other electrical parts with wet hands.

To reduce the risk of electric shock and injury from the fan or other rotating parts, stop the operation and turn off the main power before cleaning, maintaining, or inspecting the unit.

To reduce the risk of burns or frost bites, do not touch the refrigerant pipes or refrigerant circuit components with bare hands during and immediately after operation.

Before cleaning the unit, switch off the power. (Unplug the unit, if it is plugged in.)

To reduce the risk of injury, keep children away while installing, inspecting, or repairing the unit.

Children should be supervised to ensure that they do not play with the appliance.

This appliance is not intended for use by persons (including children) with reduced physical, sensory or mental capabilities, or lack of experience and knowledge, unless they have been given supervision or instruction concerning use of the appliance by a person responsible for their safety.

Keep the space well ventilated. Refrigerant can displace air and cause oxygen starvation.

If leaked refrigerant comes in contact with a heat source, toxic gas may be generated.

Always replace a fuse with one with the correct current rating.

The use of improperly rated fuses or a substitution of fuses with steel or copper wire may result in fire or explosion.

If any abnormality (e.g., burning smell) is noticed, stop the operation, turn off the power switch, and consult your dealer.

Continuing the operation may result in electric shock, malfunctions, or fire.

Properly install all required covers and panels on the terminal box and control box to keep moisture and dust out.

Dust accumulation and water may result in electric shock, smoke, or fire.

Consult an authorized agency for the proper disposal of the unit.

Refrigerant oil and refrigerant that may be left in the unit pose a risk of fire, explosion, or environmental pollution.

CAUTION

To reduce the risk of fire or explosion, do not place flammable materials or use flammable sprays around the unit.

Do not operate the unit without panels and safety guards properly installed.

To reduce the risk of injury, do not sit, stand, or place objects on the unit.

Do not connect the makeup water pipe directly to the potable water pipe. Use a cistern tank between them.

Connecting these pipes directly may cause the water in the unit to migrate into the potable water and cause health problems.

To reduce the risk of adverse effects on plants and animals, do not place them where they are directly exposed to discharge air from the unit.

Do not install the unit on or over things that are vulnerable to water damage.

Condensation may drip from the unit.

The model of heat pump unit described in this manual is not intended for use to preserve food, animals, plants, precision instruments, or art work.

To reduce the risk of injury, do not touch the heat exchanger fins or sharp edges of components with bare hands.

Do not place a container filled with water on the unit.

If water spills on the unit, it may result in shorting, current leakage, electric shock, malfunction, smoke, or fire.

Always wear protective gears when touching electrical components on the unit.

Several minutes after the power is switched off, residual voltage may still cause electric shock.

To reduce the risk of injury, do not insert fingers or foreign objects into air inlet/outlet grills.

To reduce the risk of injury, wear protective gear when working on the unit.

Do not release refrigerant into the atmosphere. Collect and reuse the refrigerant, or have it properly disposed of by an authorized agency.

Refrigerant poses environmental hazards if released into the air.

To prevent environmental pollution, dispose of brine in the unit and cleaning solutions according to the local regulations.

It is punishable by law not to dispose of them according to the applicable laws.

The water heated by the heat pump is not suitable for use as drinking water or for cooking.

It may cause health problems or degrade food.

In areas where temperature drops to freezing during the periods of non-use, blow the water out of the pipes or fill the pipes with anti-freeze solution.

Not doing so may cause the water to freeze, resulting in burst pipes and damage to the unit or the furnishings.

In areas where temperature drops to freezing, use an anti-freeze circuit and leave the main power turned on to prevent the water in the water circuit from freezing and damaging the unit or causing water leakage and resultant damage to the furnishings.

Use clean tap water.

The use of acidic or alkaline water or water high in chlorine may corrode the unit or the pipes, causing water leakage and resultant damage to the furnishings.

In areas where temperature can drop low enough to cause the water in the pipes to freeze, operate the unit often enough to prevent the water from freezing.

Frozen water in the water circuit may cause the water to freeze, resulting in burst pipes and damage to the unit or the furnishings.

Periodically inspect and clean the water circuit.

Dirty water circuit may compromise the unit's performance or corrodes the unit or cause water leakage and resultant damage to the furnishings.

Ensure that the flow rate of the feed-water is within the permitted range.

If the flow rate exceeds the permitted range, the unit may become damaged due to corrosion. Furniture may become wet due to water leaks.

Transportation

WARNING

Lift the unit by placing the slings at designated locations. Support the outdoor unit securely at four points to keep it from slipping and sliding.

If the unit is not properly supported, it may fall and cause personal injury.

CAUTION

To reduce the risk of injury, do not carry the product by the PP bands that are used on some packages.

To reduce the risk of injury, products weighing 20 kg or more should be carried by two or more people.

Installation

WARNING

Do not install the unit where there is a risk of leaking flammable gas.

If flammable gas accumulates around the unit, it may ignite and cause a fire or explosion.

Properly dispose of the packing materials.

Plastic bags pose suffocation hazard to children.

The unit should be installed only by personnel certified by Mitsubishi Electric according to the instructions detailed in the Installation/Operation Manual.

Improper installation may result in refrigerant leakage, water leakage, injury, electric shock, or fire.

Periodically check the installation base for damage.

If the unit is left on a damaged base, it may fall and cause injury.

Remove packing materials from the unit before operating the unit. Note that some accessories may be taped to the unit. Properly install all accessories that are required.

Failing to remove the packing materials or failing to install required accessories may result in refrigerant leakage, oxygen starvation, smoke, or fire.

Consult your dealer and take appropriate measures to safeguard against refrigerant leakage and resultant oxygen starvation. An installation of a refrigerant gas detector is recommended.

Any additional parts must be installed by qualified personnel. Only use the parts specified by Mitsubishi Electric.

Take appropriate safety measures against wind gusts and earthquakes to prevent the unit from toppling over and causing injury.

Be sure to install the unit horizontally, using a level.

If the unit is installed at an angle, it may fall and cause injury or cause water leakage.

The unit should be installed on a surface that is strong enough to support its weight.

As an anti-freeze, use ethylene glycol or propylene glycol diluted to the specified concentration.

The use of other types of anti-freeze solution may cause corrosion and resultant water leakage. The use of flammable anti-freeze may cause fire or explosion.

CAUTION

Do not install the unit on or over things that are vulnerable to water damage.

When the indoor humidity exceeds 80% or if the drain water outlet becomes clogged, condensation may drip from the indoor unit onto the ceiling or floor.

All drainage work should be performed by the dealer or qualified personnel according to the instructions detailed in the Installation Manual.

Improper drainage work may cause rain water or drain water to enter the buildings and damage the furnishings.

Pipe installation

WARNING

To prevent explosion, do not heat the unit with refrigerant gas in the refrigerant circuit.

Check for refrigerant leakage at the completion of installation.

If leaked refrigerant comes in contact with a heat source, toxic gas may be generated.

CAUTION

Check that no substance other than the specified refrigerant (R410A) is present in the refrigerant circuit.

Infiltration of other substances may cause the pressure to rise abnormally high and cause the pipes to explode.

To keep the ceiling and floor from getting wet due to condensation, properly insulate the pipes.

Piping work should be performed by the dealer or qualified personnel according to the instructions detailed in the Installation Manual.

Improper piping work may cause water leakage and damage the furnishings.

To keep the ceiling and floor from getting wet due to condensation, properly insulate the pipes.

Electrical wiring

To reduce the risk of wire breakage, overheating, smoke, and fire, keep undue force from being applied to the wires.

Properly secure the cables in place and provide adequate slack in the cables so as not to stress the terminals.

Improperly connected cables may break, overheat, and cause smoke or fire.

To reduce the risk of injury or electric shock, switch off the main power before performing electrical work.

All electric work must be performed by a qualified electrician according to the local regulations, standards, and the instructions detailed in the Installation Manual.

Capacity shortage to the power supply circuit or improper installation may result in malfunction, electric shock, smoke, or fire.

To reduce the risk of electric shock, smoke, or fire, install an inverter circuit breaker on the power supply to each unit.

Use properly rated breakers and fuses (inverter breaker, Local Switch <Switch + Type-B fuse>, or no-fuse breaker).

The use of improperly rated breakers may result in malfunctions or fire.

To reduce the risk of current leakage, overheating, smoke, or fire, use properly rated cables with adequate current carrying capacity.

Keep the unsheathed part of cables inside the terminal block.

If unsheathed part of the cables come in contact with each other, electric shock, smoke, or fire may result.

Proper grounding must be provided by a licensed electrician. Do not connect the grounding wire to a gas pipe, water pipe, lightning rod, or telephone wire.

Improper grounding may result in electric shock, smoke, fire, or malfunction due to electrical noise interference.

⚠ CAUTION

To reduce the risk of current leakage, wire breakage, smoke, or fire, keep the wiring out of contact with the refrigerant pipes and other parts, especially sharp edges.

To reduce the risk of electric shock, shorting, or malfunctions, keep wire pieces and sheath shavings out of the terminal block.

Transportation and repairs

⚠ WARNING

The unit should be moved, disassembled, or repaired only by qualified personnel. Do not alter or modify the unit.

Improper repair or unauthorized modifications may result in refrigerant leakage, water leakage, injury, electric shock, or fire.

After disassembling the unit or making repairs, replace all components as they were.

Failing to replace all components may result in injury, electric shock, or fire.

If the supply cord is damaged, it must be replaced by the manufacturer, its service agent or similarly qualified persons in order to avoid a hazard.

⚠ CAUTION

To reduce the risk of shorting, electric shock, fire, or malfunction, do not touch the circuit board with tools or with your hands, and do not allow dust to accumulate on the circuit board.

IMPORTANT

To avoid damage to the unit, use appropriate tools to install, inspect, or repair the unit.

To reduce the risk of malfunction, turn on the power at least 12 hours before starting operation, and leave the power turned on throughout the operating season.

Recover all refrigerant from the unit.

It is punishable by law to release refrigerant into the atmosphere.

Do not unnecessarily change the switch settings or touch other parts in the refrigerant circuit.

Doing so may change the operation mode or damage the unit.

To reduce the risk of malfunctions, use the unit within its operating range.

Do not switch on or off the main power in a cycle of shorter than 10 minutes.

Short-cycling the compressor may damage the compressor.

To maintain optimum performance and reduce the risk of malfunction, keep the air pathway clear.

To reduce the risk of both the breaker on the product side and the upstream breaker from tripping and causing problems, split the power supply system or provide protection coordination between the earth leakage breaker and no-fuse breaker.

When servicing the refrigerant, open and close the check joint using two spanners, as there is the risk of refrigerant leaking due to damaged piping.



Please build the water circuit so that it is a closed system.

Do not use water directly for showers or other applications. Do not allow other heat source water to mix with the water circuit.

To ensure proper operation of the unit, periodically check for proper concentration of anti-freeze.

Inadequate concentration of anti-freeze may compromise the performance of the unit or cause the unit to abnormally stop.

Take appropriate measures against electrical noise interference when installing the air conditioners in hospitals or facilities with radio communication capabilities.

Inverter, high-frequency medical, or wireless communication equipment as well as power generators may cause the air conditioning system to malfunction. Air conditioning system may also adversely affect the operation of these types of equipment by creating electrical noise.

Check the water system, using a relevant manual as a reference.

Using the system that does not meet the standards (including water quality and water flow rate) may cause the water pipes to corrode.

To reduce the risk of power capacity shortage, always use a dedicated power supply circuit.

Have a backup system, if failure of the unit has a potential for causing significant problems or damages.

This appliance is intended to be used by expert or trained users in shops, in light industry and on farms, or for commercial use by lay persons.

1. Selecting the Installation Site

[1] Installation Conditions

Select the installation site in consultation with the client.

Select a site to install the unit that meets the following conditions:

- The unit will not be subject to heat from other heat sources.
- The noise from the unit will not be a problem.
- The unit will not be exposed to strong winds.
- Water from the unit can be drained properly.
- The space requirements (specified on pages 7 through 11) are met.
- There is a possibility of injuring with the fin of the heat exchanger, so abide by following contents.

- ① Limit the access of the general public to the location where they can touch the product.
 - ② Take a measure so the general public cannot easily access the location where they can touch the product.
 - ③ When installing in a location where the general public can touch the product, install the optional fin guard.
- Option Parts: EA-130FG

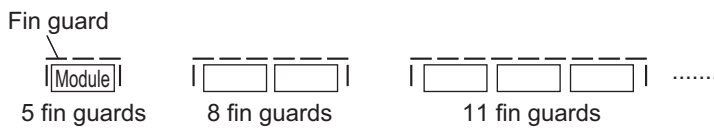

<1> Protection against winds

- Pay attention to the wind direction and installation location to ensure that the air heat exchanger is not directly exposed to strong winds.
- If unable to avoid strong winds, install wind breaking hoods or walls, etc.

<2> Cold Climate Installation

Observe the following when installing the units in areas where snow or strong winds prevail.

- Avoid direct exposure to rain, winds, and snow.
- If the unit is installed in the direct line of rain, winds, or snow, install snow hoods. Use a snow net or snow fence as necessary to protect the unit.
- Install the unit on a base approximately twice as high as the expected snowfall.
- If the unit of heating mode is continuously operated for a long time with the outdoor temperature below the freezing point, install a heater at the drain pan of the unit to prevent freezing of drain.

[2] Installation Space Requirement

<1> If there are no walls, etc. in surrounding area

(1) Single unit installation space

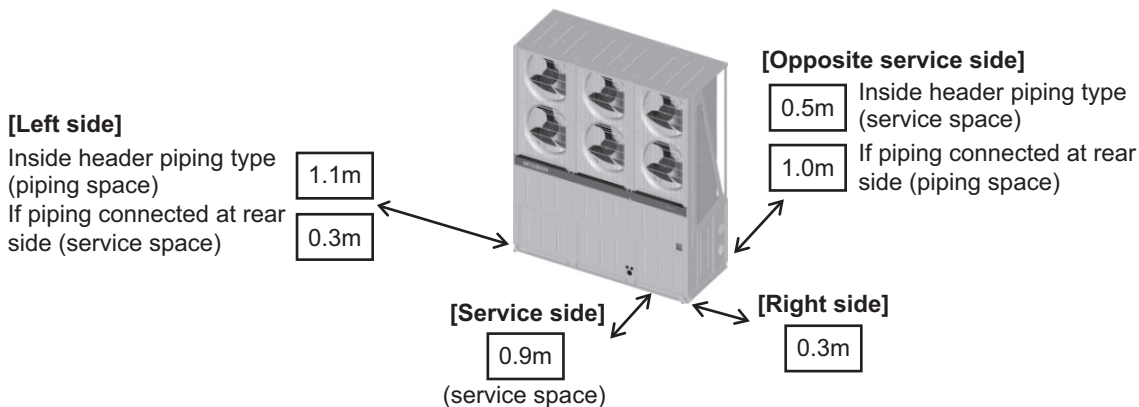

*The inside header piping type shows case of piping from the left side of the unit.

(2) Connected modules installation space

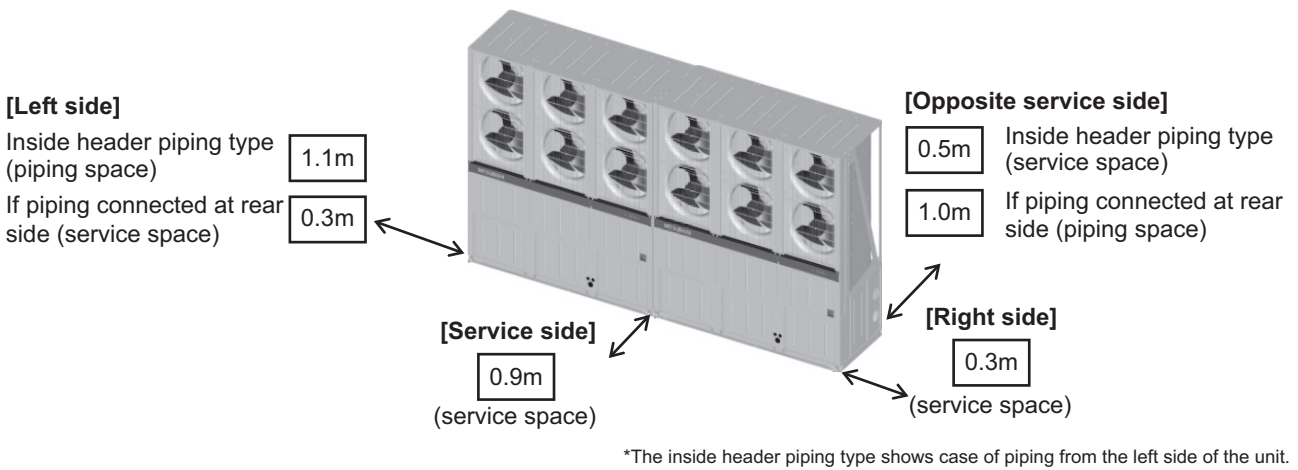

(3) Discharge side installation space (If 2 rows)

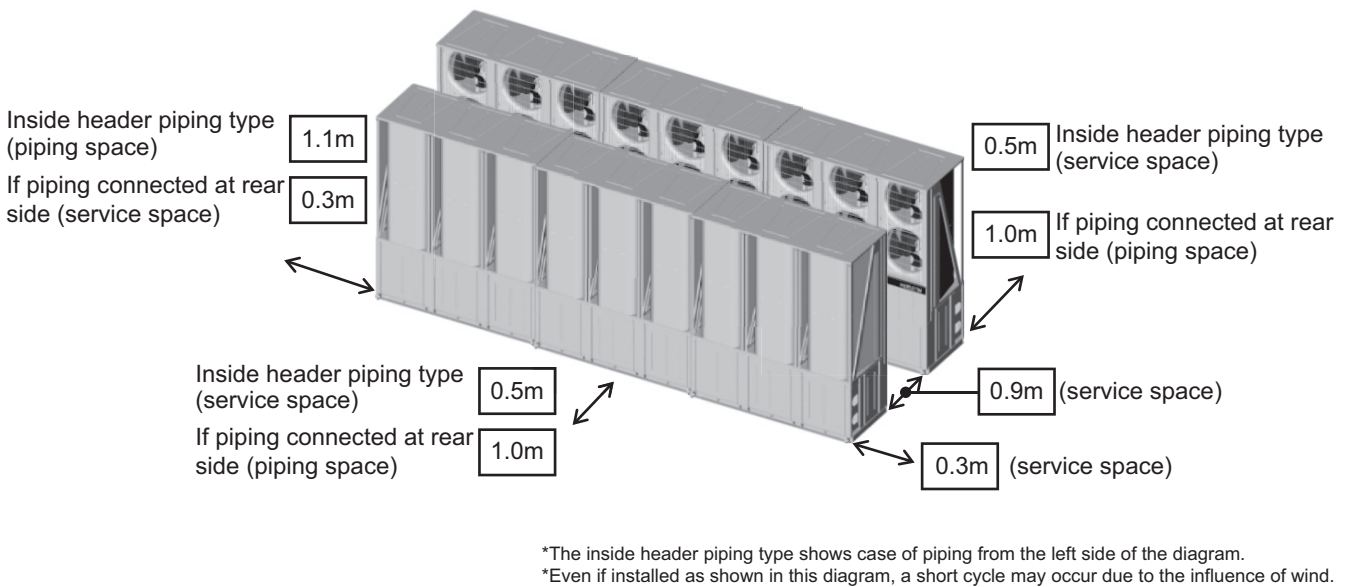

(4) Discharge side installation space (if 4 rows × 2)

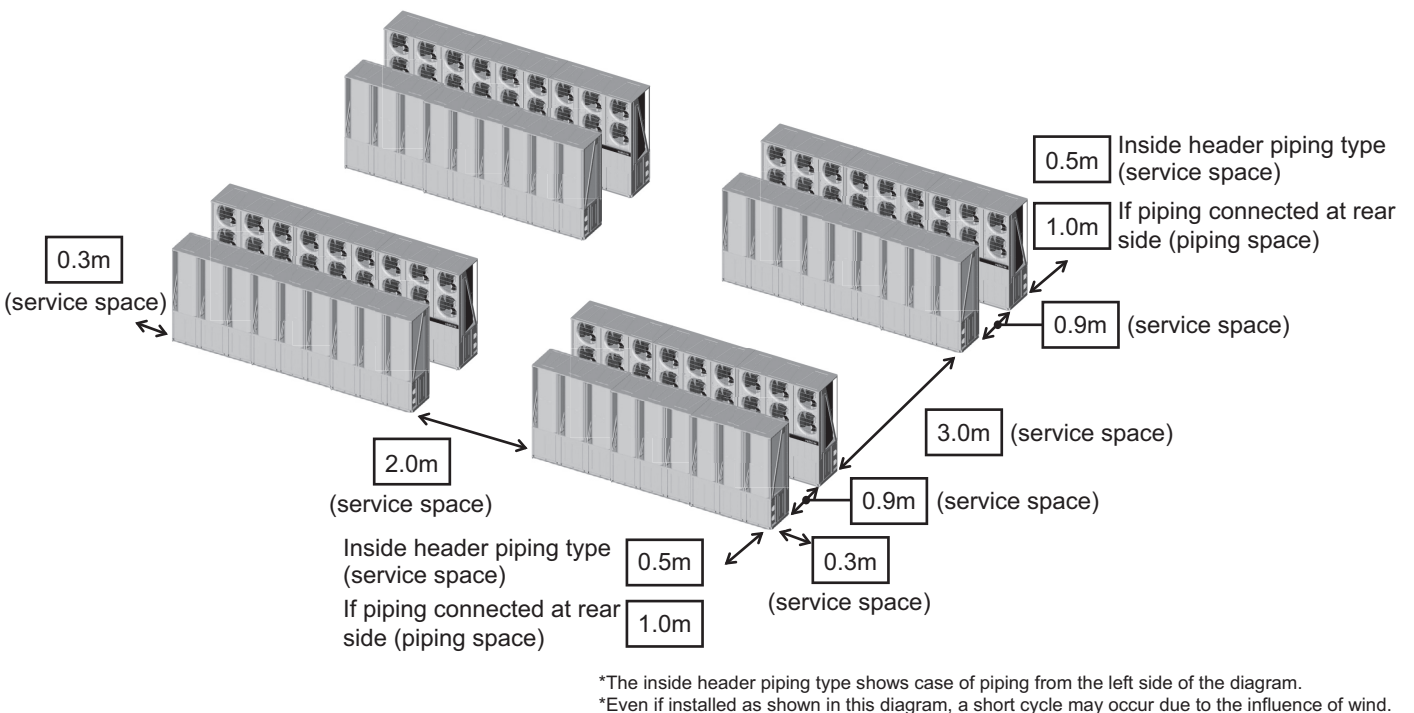

<2> If there are walls, etc. in surrounding area

(1) If installing a single unit in front of a wall

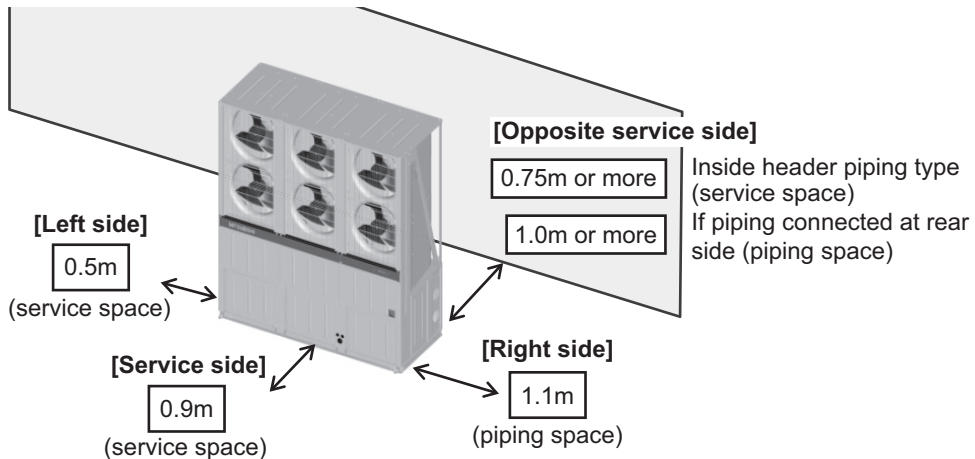

*The inside header piping type shows case of piping from the right side of the unit.
*Even if installed as shown in this diagram, a short cycle may occur due to the influence of wind.

(2) If installing 3 connected modules in front of a wall

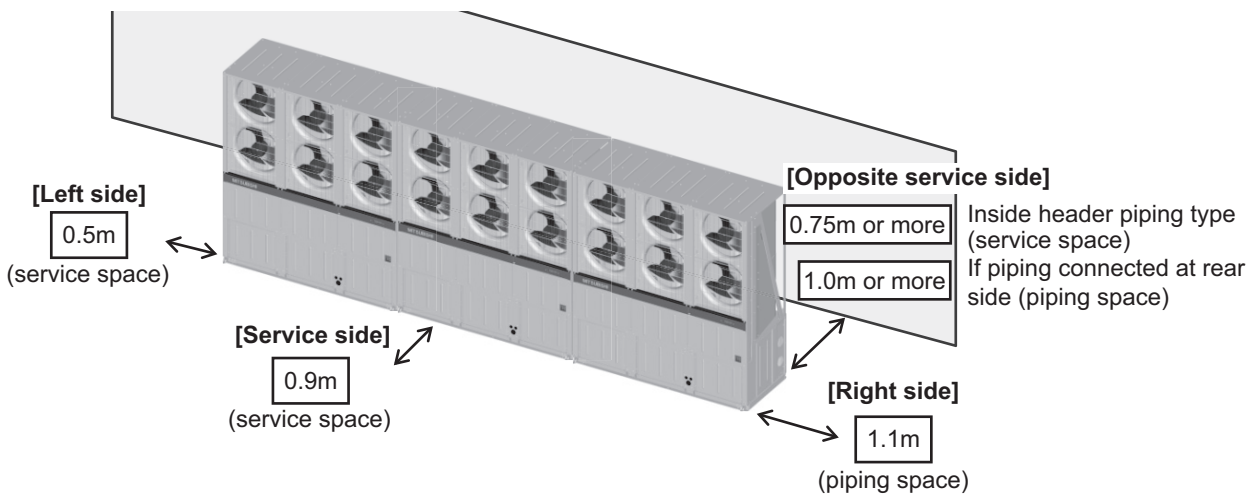

*The inside header piping type shows case of piping from the right side of the unit.
*Even if installed as shown in this diagram, a short cycle may occur due to the influence of wind.

(3) If installing 4 to 6 connected modules in front of a wall

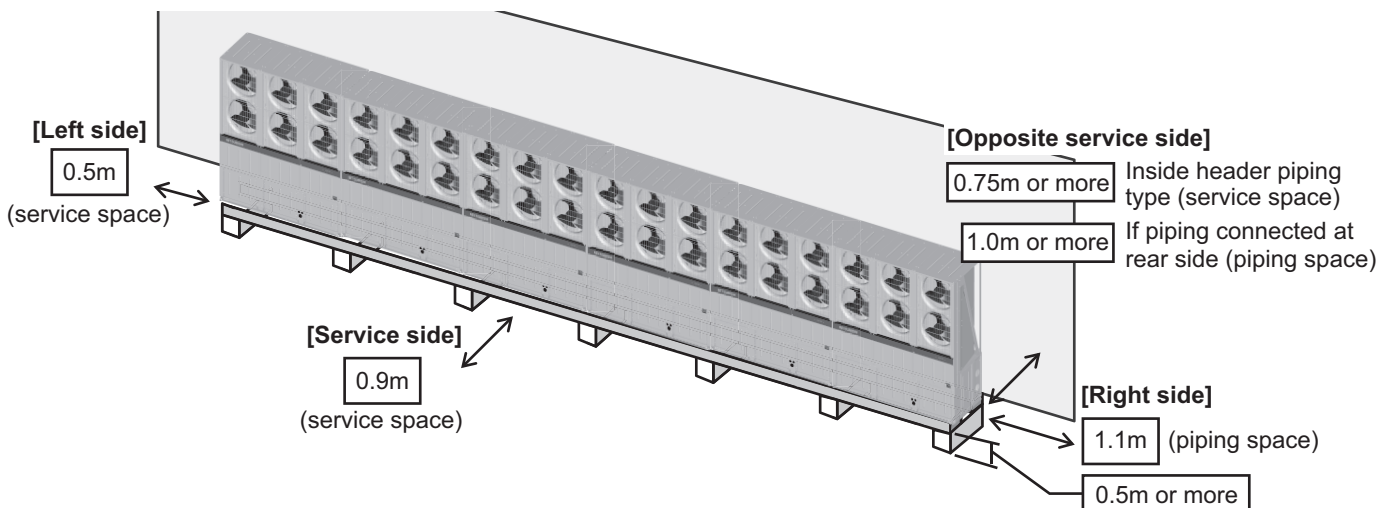

*The inside header piping type shows case of piping from the right side of the unit.
*Even if installed as shown in this diagram, a short cycle may occur due to the influence of wind.

(4) If installing multiple sets of 3 connected modules in front of a wall

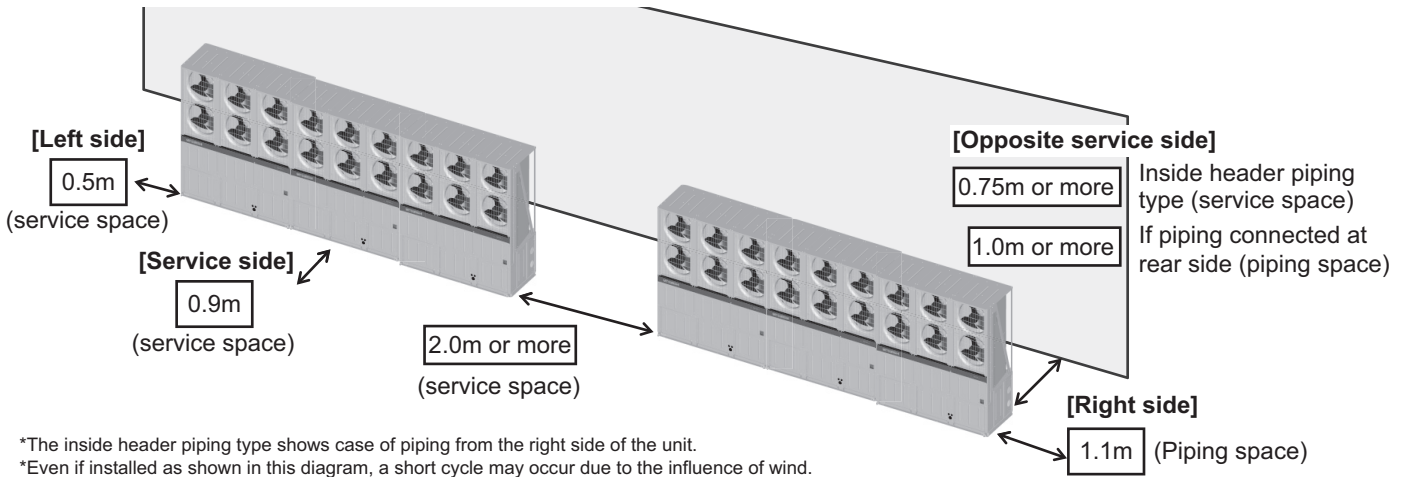

(5) If installing 4 to 6 connected modules in front of a wall (when intake side facing out)

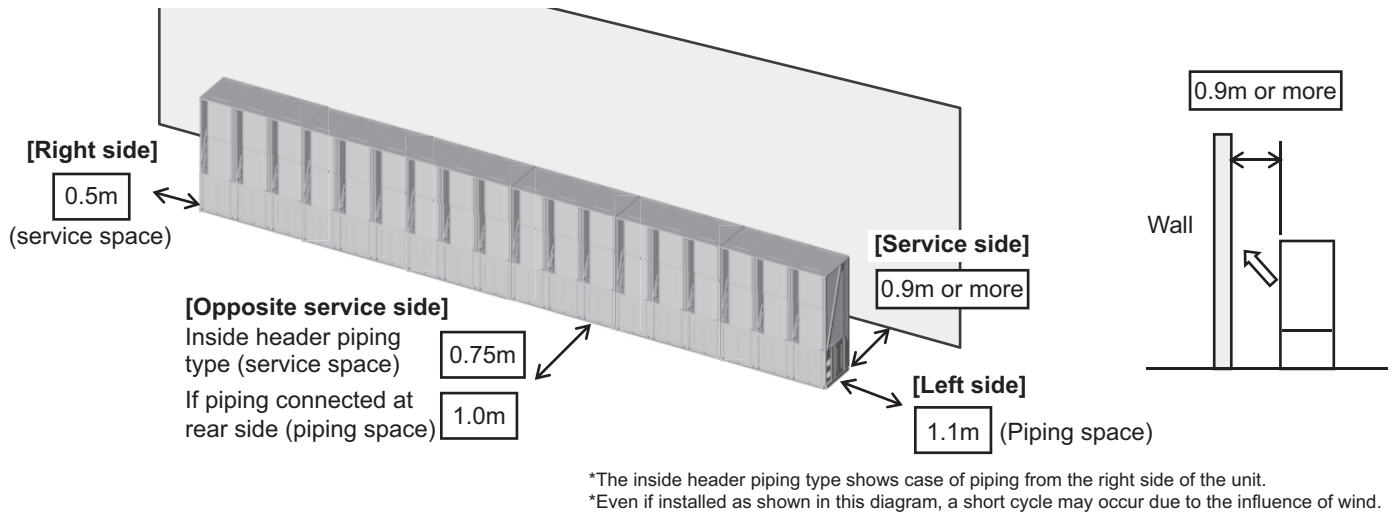

<3> If surrounding area enclosed by walls

(1) If installing a single unit on an L-shaped wall

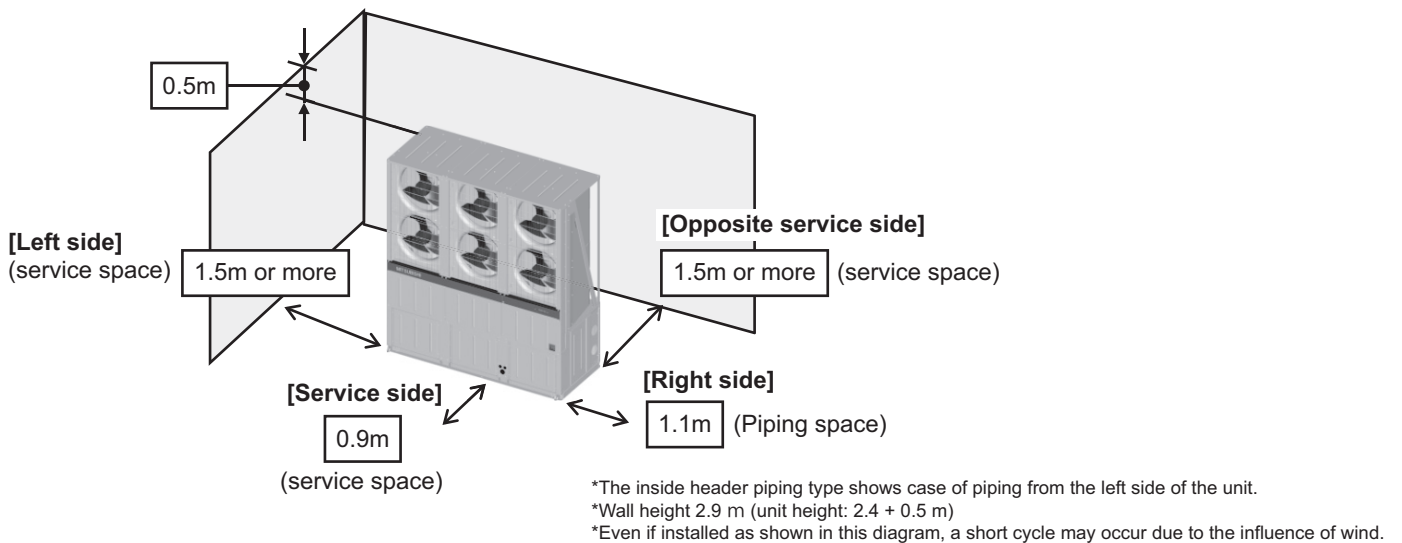

(2) If entire surrounding area enclosed by walls (but vent holes installed at bottom of wall)

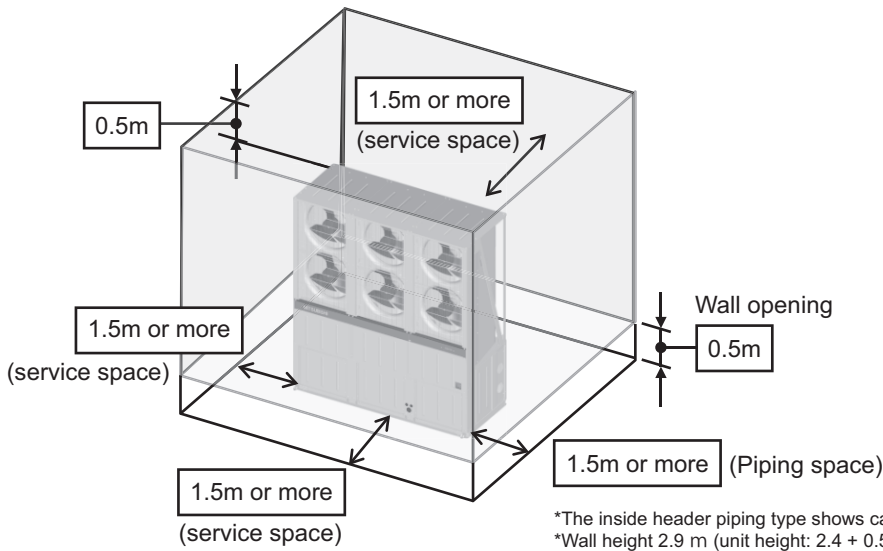

*The inside header piping type shows case of piping from the left side of the diagram.
 *Wall height 2.9 m (unit height: 2.4 + 0.5 m)
 *Vent holes: 0.5 m from floor
 *Even if installed as shown in this diagram, a short cycle may occur due to the influence of wind.

(3) If entire surrounding area enclosed by walls, and units face one another (but vent holes installed at bottom of wall)

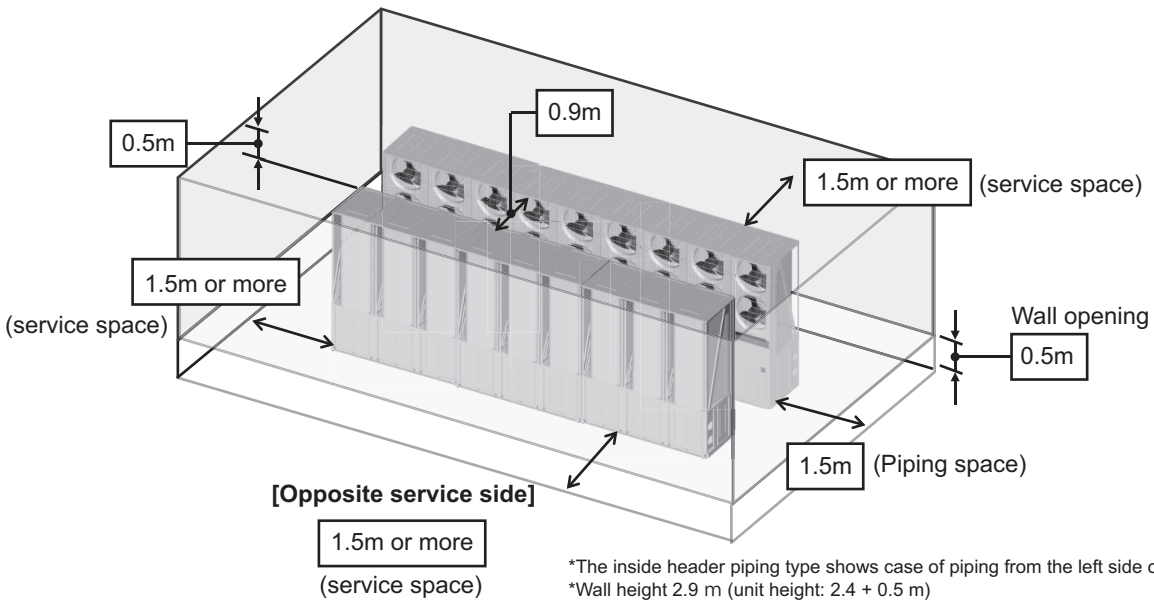

*The inside header piping type shows case of piping from the left side of the diagram.
 *Wall height 2.9 m (unit height: 2.4 + 0.5 m)
 *Vent holes: 0.5 m from floor
 *Even if installed as shown in this diagram, a short cycle may occur due to the influence of wind.

2. Unit Installation

Units should be installed only by personnel certified by Mitsubishi Electric.

[1] Product suspension method

- If transporting the product suspended, use the two suspension sections at the front and rear.
- Always feed rope through the four suspension sections so that the unit is not subjected to shocks.
- Use two ropes that are 8 m or longer. (Use four ropes that are 4 m or longer.)
- Use suspension equipment that is capable of supporting the weight of the product.
- Always suspend the product in four sections. (do not suspend the product two sections as this is dangerous)
- Use the appropriate protective pads to ensure that the rope does not rub against the outer panel.
- Refer to the center of gravity position shown in [2], and suspend the unit while taking care to prevent a deviated center of gravity.

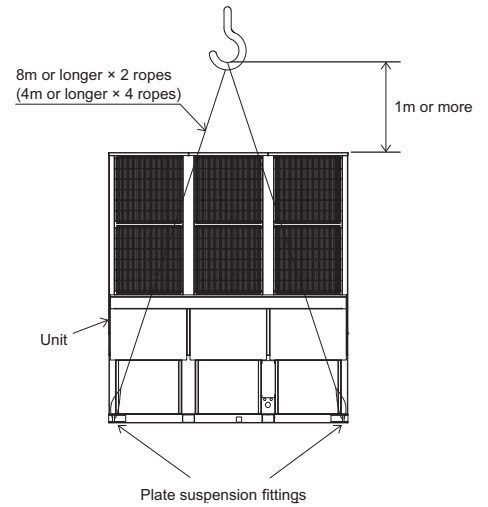

⚠ Warning:

- Lift the unit by placing the slings at designated locations. Support the unit securely at four points to keep it from slipping and sliding. If the unit is not properly supported, it may fall and cause personal injury.

[2] Center of gravity position

The center of gravity position is shown with the  mark.

Standard piping type

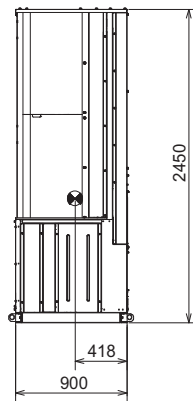

Left side

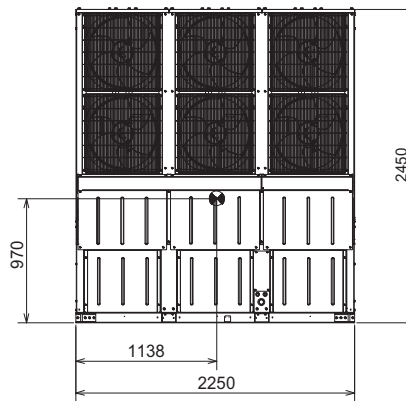

Service side

Inside header piping type

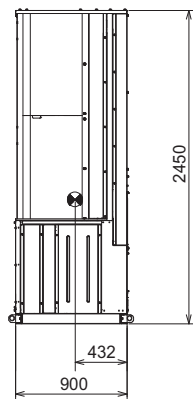

Left side

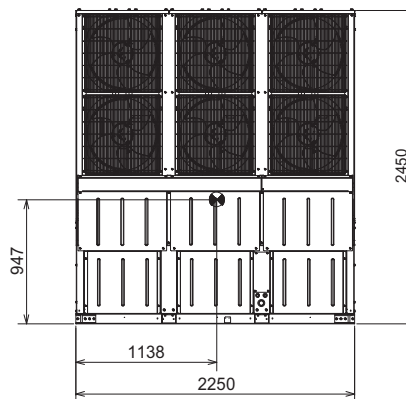

Service side

[3] Installation on foundation

- Securely fix the unit with bolts to keep the unit from falling down during earthquakes.
- Install the unit on a foundation made of concrete or iron.
- Noise and vibrations from the unit may be transmitted through the floor and walls. Provide adequate protection against noise and vibration.

Warning:

- Be sure to install the unit on a surface strong enough to withstand its weight to keep the unit from falling down and causing injury.
- Provide adequate protection against earthquakes. Improper installation may cause the unit to fall down, resulting in personal injury.

When building the foundation, take the floor strength, and piping and wiring routes into consideration.

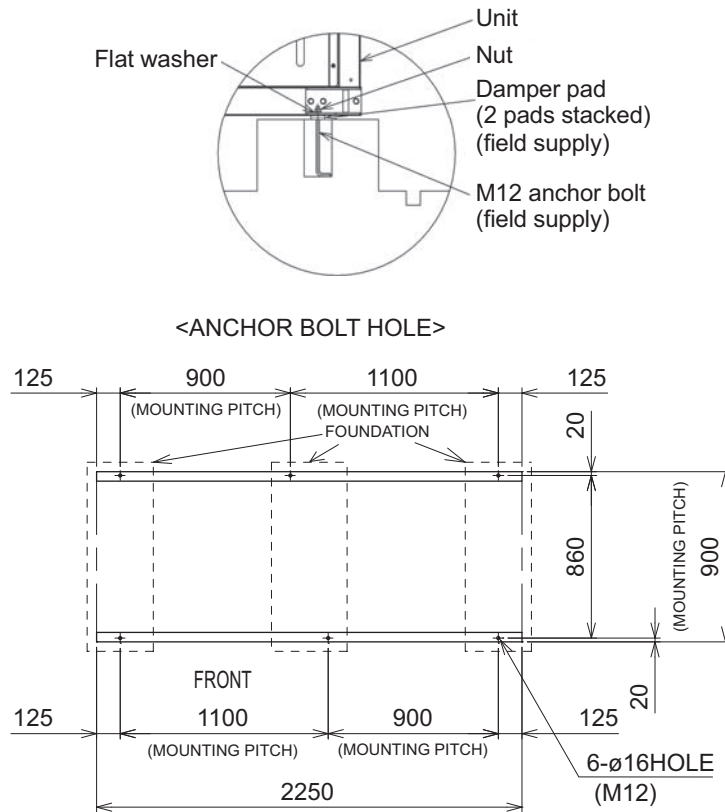

[4] Add the refrigerant

- Amount of factory-charged refrigerant is 6 kg x 2.
- Add the refrigerant of 13 kg x 2 in the field. (Rated charged refrigerant is 19 kg x 2)

R410A

⚠ WARNING

Do not use refrigerant other than the type indicated in the manuals provided with the unit and on the nameplate.

- Doing so may cause the unit or pipes to burst, or result in explosion or fire during use, during repair, or at the time of disposal of the unit.
- It may also be in violation of applicable laws.
- MITSUBISHI ELECTRIC CORPORATION cannot be held responsible for malfunctions or accidents resulting from the use of the wrong type of refrigerant.

⚠ CAUTION

If there is excess or shortage in the refrigerant charge, the unit may come to an abnormal stop.

Position of the check joint

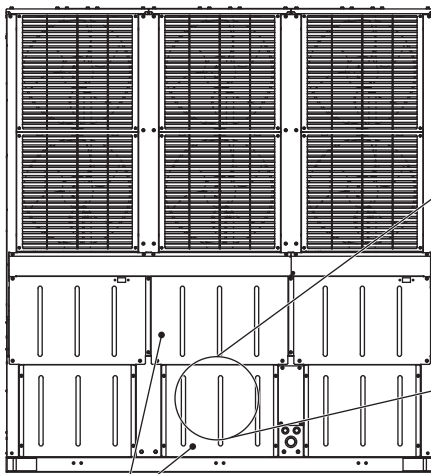

Remove these panels.

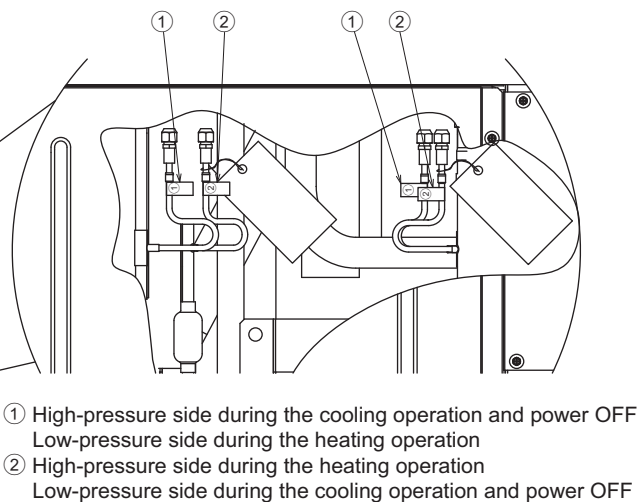

- ① High-pressure side during the cooling operation and power OFF
Low-pressure side during the heating operation
- ② High-pressure side during the heating operation
Low-pressure side during the cooling operation and power OFF

- Open and close the check joint using two spanners.
- Fasten the check joint in the torque of 7-9 N•m.
- Remove the two tags after adding the refrigerant.

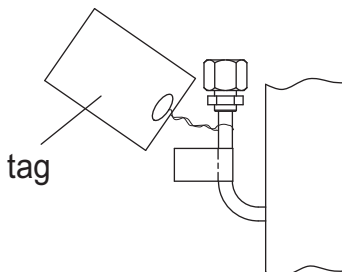

Refrigerant charging

⚠ CAUTION

- During operation, be sure to wear safety goggles and protective gloves.
- If air is mixed in refrigeration cycle, poor cooling may result, and also if moisture is mixed in refrigeration cycle, clogging (freezing) or rust may result.

(1) Refrigerant charging type

- Cylinder color is Pink (R410A).
- Refrigerant charging in the liquid state
- Charge refrigerant through the check joint (refer to Page 14).

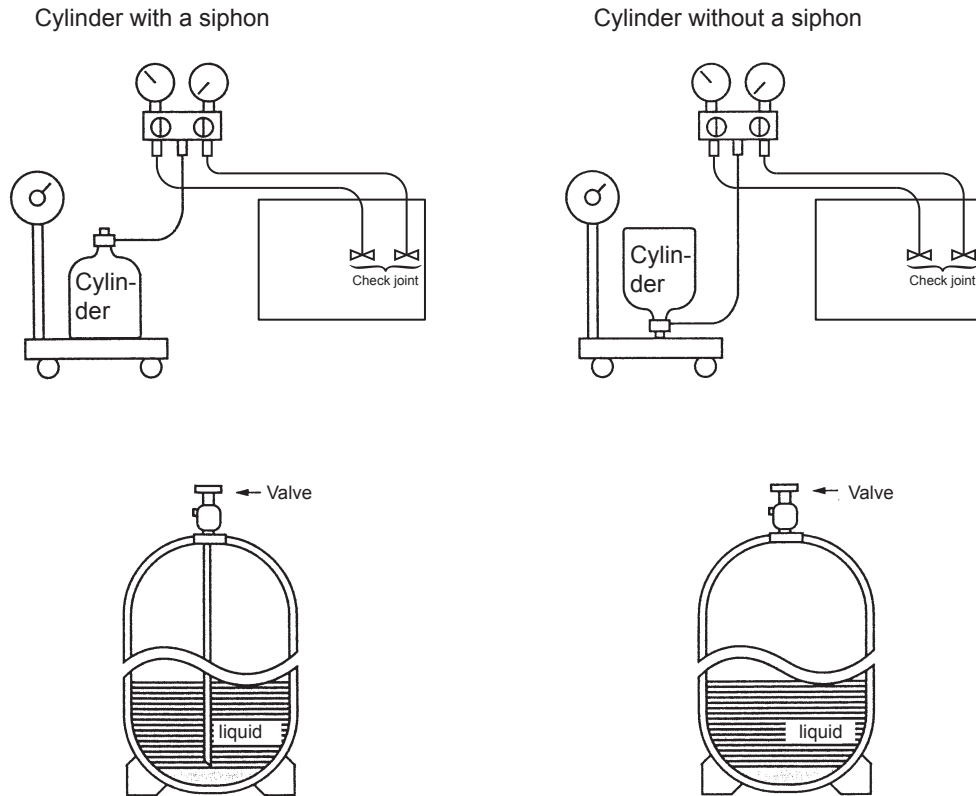

- *1 Charging refrigerant through the check joint only on the low-pressure side will create reverse pressure, resulting in compressor malfunctions.
- *2 R410A is a mixture of 2 refrigerants, each with a different evaporation temperature. Therefore, if the equipment is charged with R410A gas, then the refrigerant whose evaporation temperature is closest to the outside temperature is charged first while the rest of refrigerants remain in the cylinder.
- *3 When using a cylinder with a siphon, refrigerant is charged in the liquid state without the need for turning it upside down. Check the type of the cylinder on the label before use.

Manifold gauge

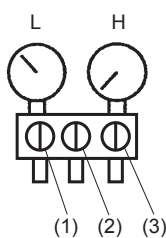

- L: Low pressure gauge
- H: High pressure gauge
- (1) Low pressure valve
- (2) Refrigerant charging valve
- (3) High pressure valve

(2) Refrigerant charging procedure

- 1) Connect the center manifold hose to the valve of the cylinder. Then, close all valves of the manifold gauge.
- 2) When filling the refrigerant, measure the refrigerant amount using a weight scale. Then, connect all the manifold hoses.
- 3) Open the valve on the cylinder.
- 4) Loosen the center manifold hose connection on the manifold gauge set (if applicable, press a purge valve on the manifold gauge) only for a couple of seconds to allow the air in the center manifold hose to be bled by the refrigerant pressure.
- 5) Open the high pressure side valve and the low pressure side valve on the manifold gauge and fill the coolant.

When charging refrigerant while driving the compressor, do not open the high pressure side valve. Always make sure to fill from the lower pressure side while driving the compressor.

3. Water Pipe Installation

[1] Schematic Piping Diagram and Piping System Components

Please build the water circuit so that it is a closed system.

Do not use water directly for showers or other applications.
Do not allow other heat source water to mix with the water circuit.
Build a water circuit as inlet water temperature fluctuation is within 5°C/10 minutes.

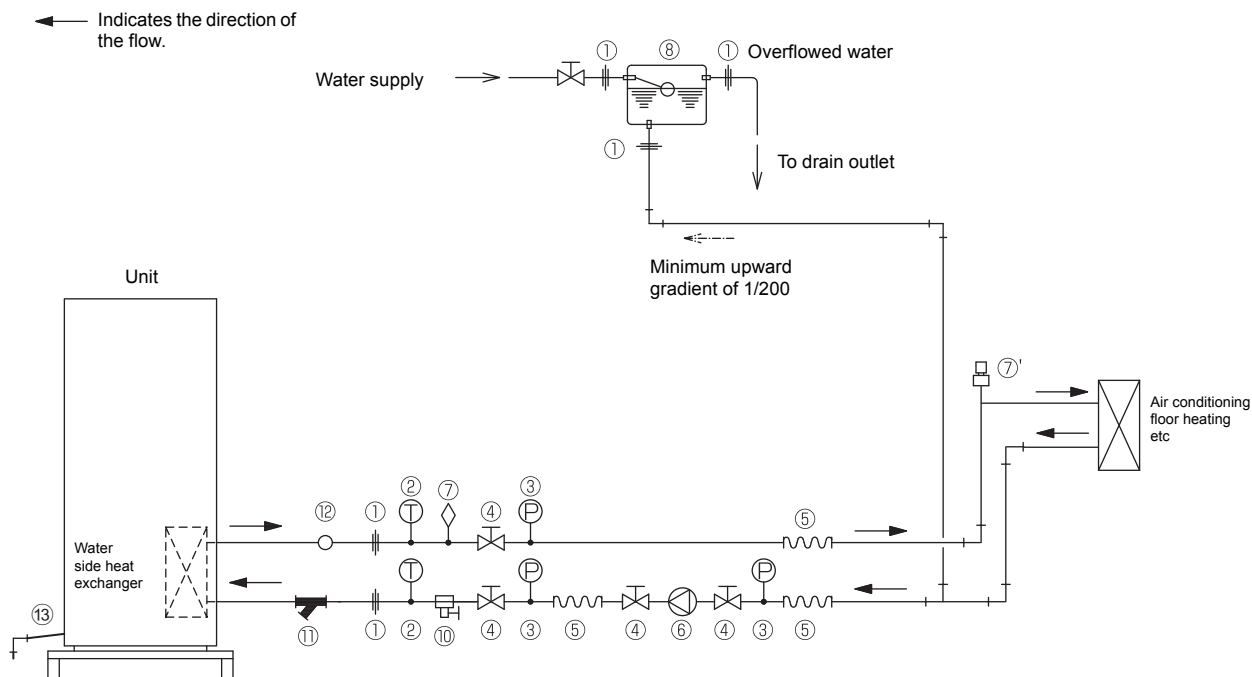

① Union joints/flange joints	Required to allow for a replacement of equipment.
② Thermometer	Required to check the performance and monitor the operation of the units.
③ Water pressure gauge	Recommended for checking the operation status.
④ Valve	Required to allow for a replacement or cleaning of the flow adjuster.
⑤ Flexible joint	Recommended to prevent the noise and vibration from the pump from being transmitted.
⑥ Pump	Use a pump that is large enough to compensate for the total water pressure loss and supply sufficient water to the unit.
⑦ Air vent valve	Install air venting valves to the places where air can accumulate. Automatic air vent valves (such as ⑦') are effective.
⑧ Expansion tank	Install an expansion tank to accommodate expanded water and to supply water.
⑨ Water pipe	Use pipes that allow for easy air purging, and provide adequate insulation.
⑩ Drain valve	Install drain valves so that water can be drained for servicing.
⑪ Strainer	Install a strainer near the unit to keep foreign materials from entering the water-side head exchanger.
⑫ Flow switch	Required to protect the unit.
⑬ Drain pipe	Install the drain pipe with a downward inclination of between 1/100 and 1/200. To prevent drain water from freezing in winter, install the drain pipe as steep an angle as practically possible and minimize the straight line. For cold climate installation, take an appropriate measure (e.g., drain heater) to prevent the drain water from freezing.

[2] Water piping attachment method

Standard piping type

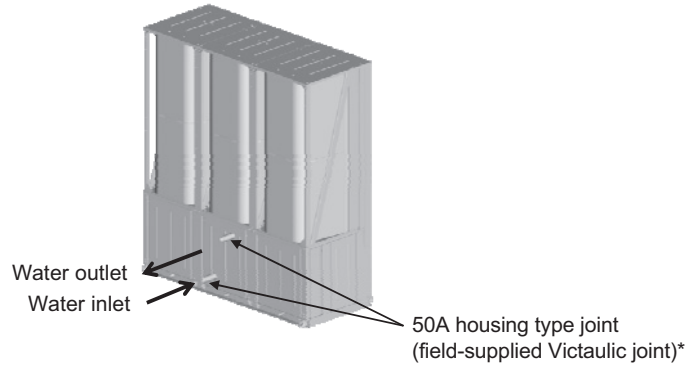

* Victaulic standard groove specifications

Machine grooves to secure housing joints to field-supplied pipes based on the following dimensions.

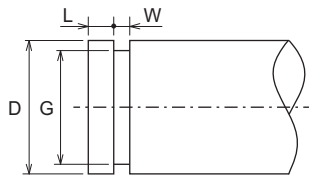

	Pipe size
	50A
D	$\varnothing 60.3 \pm 0.61$
G	$\varnothing 57.15 \begin{smallmatrix} 0 \\ -0.38 \end{smallmatrix}$
L	15.88 ± 0.76
W	7.95 ± 0.76

Inside header piping type

It requires optional Inside header piping kit.

Option Parts: EA-01HK

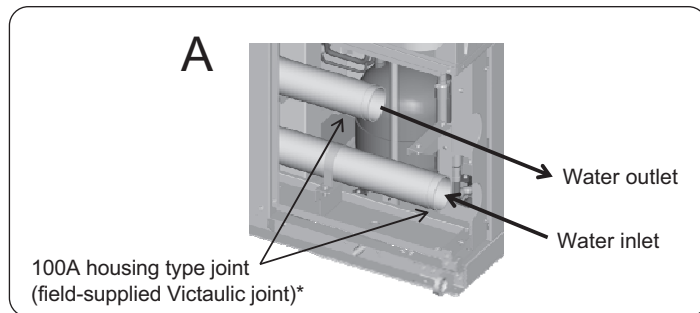
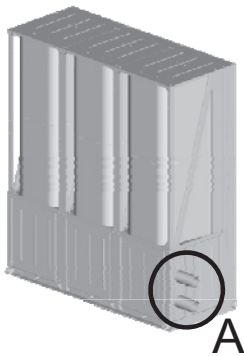

* Victaulic standard groove specifications

Machine grooves to secure housing joints to field-supplied pipes based on the following dimensions.

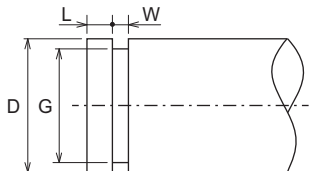

	Pipe size
	100A
D	$\varnothing 114.3 \begin{smallmatrix} +1.14 \\ -0.79 \end{smallmatrix}$
G	$\varnothing 110.08 \begin{smallmatrix} 0 \\ -0.51 \end{smallmatrix}$
L	15.88 ± 0.76
W	9.53 ± 0.76

On-site module connection and terminal work

The module connection requires the option of both Inside header piping kit (EA-01HK) and Inside header connecting kit (EA-02HK). Inside header connecting kit requires the same number as the number of connections.

Option Parts: EA-01HK
EA-02HK

* Refer to the installation instructions for the details of installation of the optional parts.

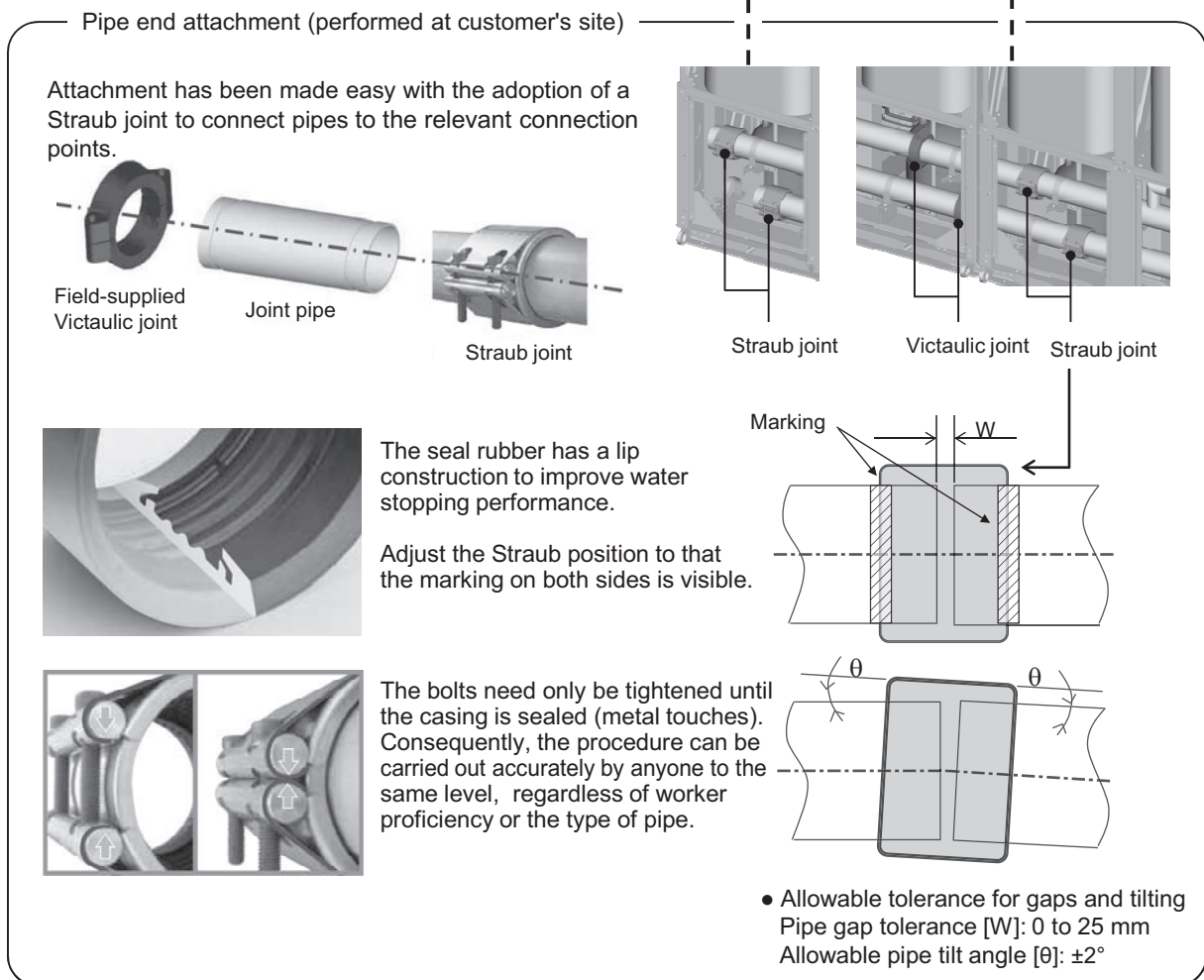
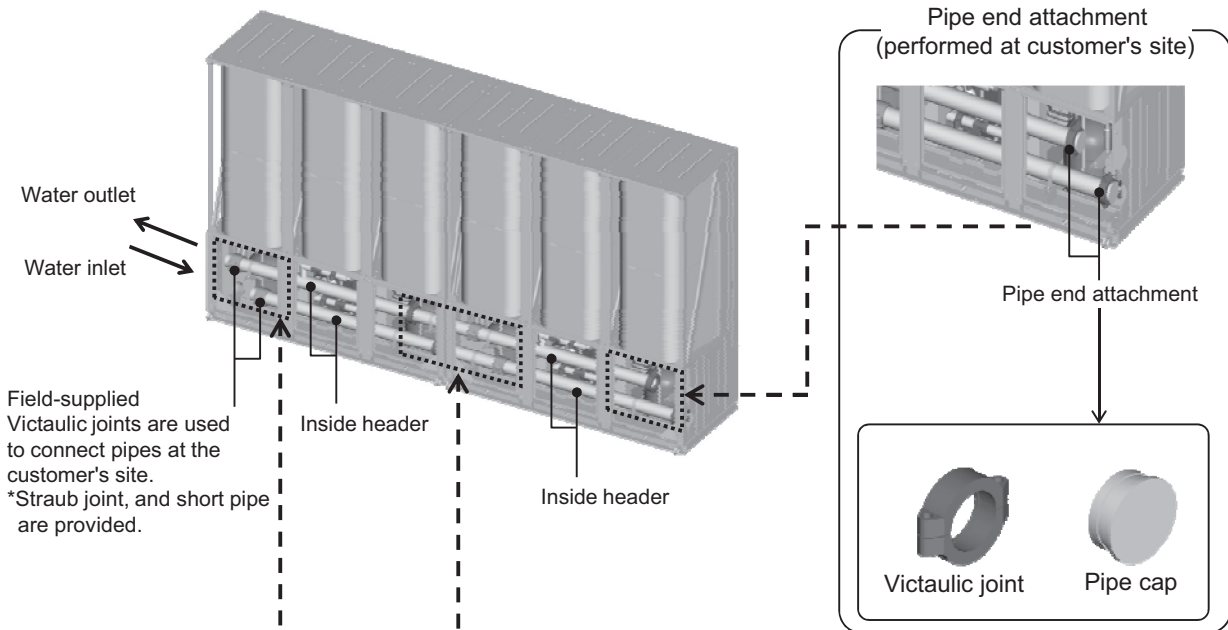

The Victaulic joints and Straub joints used in the explanation are actual product names.

[3] Notes on Pipe Corrosion

Water treatment and water quality control

Poor-quality circulating water can cause the water-side heat exchanger to scale up or corrode, reducing heat-exchange performance. Properly control the quality of the circulating water.

- Removing foreign objects and impurities in the pipes
During installation, keep foreign objects, such as welding and sealant fragments and rust, out of the pipes.
- Water Quality Control
 - (1) Poor-quality water can corrode or scale up the heat exchanger. Regular water treatment is recommended.
Water circulation systems using open heat storage tanks are particularly prone to corrosion.
When using an open heat storage tank, install a water-to-water heat exchanger, and use a closed-loop circuit.
If a water supply tank is installed, keep contact with air to a minimum, and keep the level of dissolved oxygen in the water no higher than 1 mg/ℓ.

(2) Water quality standard

Items		Lower mid-range temperature water system		Higher mid-range temperature water system		Tendency	
		Water Temp. ≤ 60°C		Water Temp. > 60°C		Corrosive	Scale-forming
		Recirculating water	Make-up water	Recirculating water	Make-up water		
Standard items	pH (25°C)	7.0 ~ 8.0	7.0 ~ 8.0	7.0 ~ 8.0	7.0 ~ 8.0	○	○
	Electric conductivity (mS/m) (25°C)	30 or less	30 or less	30 or less	30 or less	○	○
	(μS/cm) (25°C)	[300 or less]	[300 or less]	[300 or less]	[300 or less]		
	Chloride ion (mg Cl ⁻ /ℓ)	50 or less	50 or less	30 or less	30 or less	○	
	Sulfate ion (mg SO ₄ ²⁻ /ℓ)	50 or less	50 or less	30 or less	30 or less	○	
	Acid consumption (pH4.8) (mg CaCO ₃ /ℓ)	50 or less	50 or less	50 or less	50 or less		○
	Total hardness (mg CaCO ₃ /ℓ)	70 or less	70 or less	70 or less	70 or less		○
	Calcium hardness (mg CaCO ₃ /ℓ)	50 or less	50 or less	50 or less	50 or less		○
Ionic silica (mg SiO ₂ /ℓ)	30 or less	30 or less	30 or less	30 or less		○	
Reference items	Iron (mg Fe/ℓ)	1.0 or less	0.3 or less	1.0 or less	0.3 or less	○	○
	Copper (mg Cu/ℓ)	1.0 or less	1.0 or less	1.0 or less	1.0 or less	○	
	Sulfide ion (mg S ²⁻ /ℓ)	Not to be detected	Not to be detected	Not to be detected	Not to be detected	○	
	Ammonium ion (mg NH ₄ ⁺ /ℓ)	0.3 or less	0.1 or less	0.1 or less	0.1 or less	○	
	Residual chlorine (mg Cl/ℓ)	0.25 or less	0.3 or less	0.1 or less	0.3 or less	○	
	Free carbon dioxide (mg CO ₂ /ℓ)	0.4 or less	4.0 or less	0.4 or less	4.0 or less	○	
	Ryzner stability index	—	—	—	—	○	○

Reference: Guideline of Water Quality for Refrigeration and Air Conditioning Equipment. (JRA GL02E-1994)

- (3) Please consult with a water quality control specialist about water quality control methods and water quality calculations before using anti-corrosive solutions for water quality management.
- (4) When replacing an air conditioner (including when only the heat exchanger is replaced), first analyze the water quality and check for possible corrosion.
Corrosion can occur in water systems in which there has been no signs of corrosion. If the water quality level has dropped, adjust the water quality before replacing the unit.

(5) Suspended solids in the water

Sand, pebbles, suspended solids, and corrosion products in water can damage the heating surface of the heat exchanger and cause corrosion. Install a good quality strainer (20 mesh or better) at the inlet of the unit to filter out suspended solids.

Removing foreign substances from the water system

Consider installing a settlement tank or a bypass strainer to remove foreign substances from the water system. Select a strainer capable of handling two to three percent of the circulating water. The figure below shows a sample system with a bypass strainer.

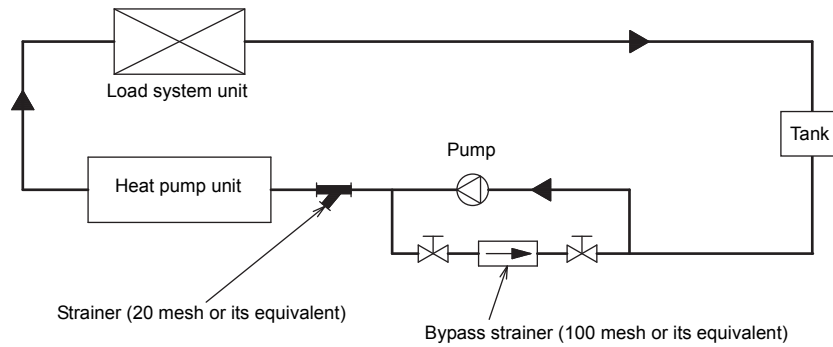

(6) Connecting pipes made from different materials

If different types of metals are placed in direct contact with each other, the contact surface will corrode. Install an insulating material between pipes that are made of different materials to keep them out of direct contact with each other.

(7) Piping material

Use hot water output piping material that can withstand heat of 60°C or more. Use hot water input piping material that can withstand the maximum input water temperature. All piping must be made of SUS or similar material to withstand corrosion.

[4] Installing the Strainer and Flow Switch

<1> Installing the strainer

Install a strainer on the inlet pipe near the unit to filter out suspended solids and prevent clogging or corrosion of the heat exchanger.

Install a strainer in a way that allows for easy access for cleaning, and instruct the user to clean it regularly.

Operating the units with a clogged strainer may cause the units to make an abnormal stop.

Select a location to install a strainer, taking into consideration the installation angle, insulation thickness, and maintenance space.

* The dimensions given below indicate the amount of space necessary when screwing in a Y-shaped strainer.

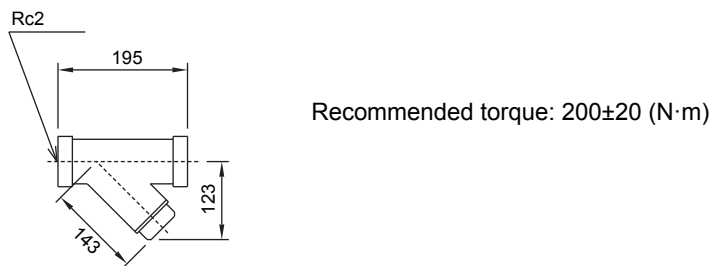

<Unit: mm>

Option Parts: YS-50A*

* YS-50A is for standard piping type.
Inside header type will need to supply a strainer (20 mesh or its equivalent) for 100A piping to the site.

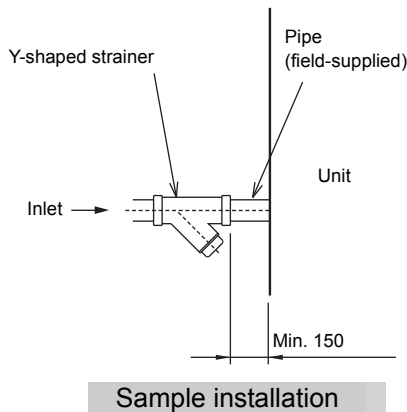

Sample installation

<2> Installing a flow switch

Install a flow switch that meets the following specifications on the water pipe.

Connect the flow switch to the flow switch contact on the unit.

Minimum flow rate= 7.7 m³/h (128 L/min)

Unit usage range (water flow rate): 7.7 - 25.8 m³/h

[5] Ensuring enough water in the water circuit

<1> Required amount of water

If the amount of water in the water circuit (circulating water circuit) is insufficient, the unit operation hours may become

shorter or the amount of water temperature change to be controlled may become extremely large. Also, the defrost operation during the heating mode may not function properly. Refer to the table below for the minimum amount of water required in the circuit. If the water pipe is too short to keep enough amount of water, install a cushion tank in the water pipe to ensure enough amount of water.

Model	Minimum amount of water (ℓ)
EAHV-P900YA(-H)	780
EACV-P900YA	420

<2> Calculating the required amount of water in the water circuit

The required amount of water in the water circuit can be obtained from the following formula.

(Required amount of water in the water circuit) = (Amount of water that can be held in the water pipe) + (Amount of water that can be held in the heat source unit) + (Amount of water that can be held in the load-side unit)

The amount of water that can be held per meter of the water pipe (ℓ/m)

Pipe size					
1 1/2B (40A)	2B (50A)	2 1/2B (65A)	3B (80A)	4B (100A)	5B (125A)
1.36	2.20	3.62	5.12	8.71	13.44

The amount of water that can be held in the heat source unit (ℓ)

EAHV-P900YA(-H), EACV-P900YA	EAHV-P900YA(-H)-N, EACV-P900YA-N
20	55

<3> Inlet/Outlet pipe connection size and material

The table below shows the inlet/outlet pipe connection size.

Inlet/Outlet pipe connection size

Model	Inlet pipe connection	Outlet pipe connection
EAHV-P900YA(-H) EACV-P900YA	50A housing type joint (Field-supplied Victaulic joint)	50A housing type joint (Field-supplied Victaulic joint)
EAHV-P900YA(-H)-N EACV-P900YA-N	100A housing type joint (Field-supplied Victaulic joint)	100A housing type joint (Field-supplied Victaulic joint)

[6] Water Piping Size and Location

<1> Standard piping type

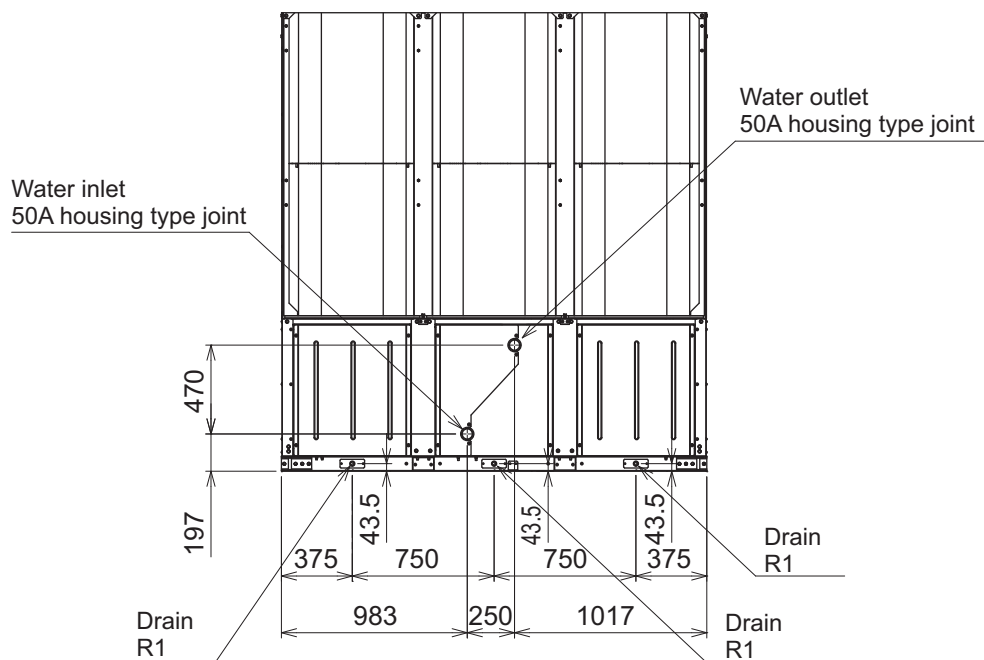

<2> Inside header piping type

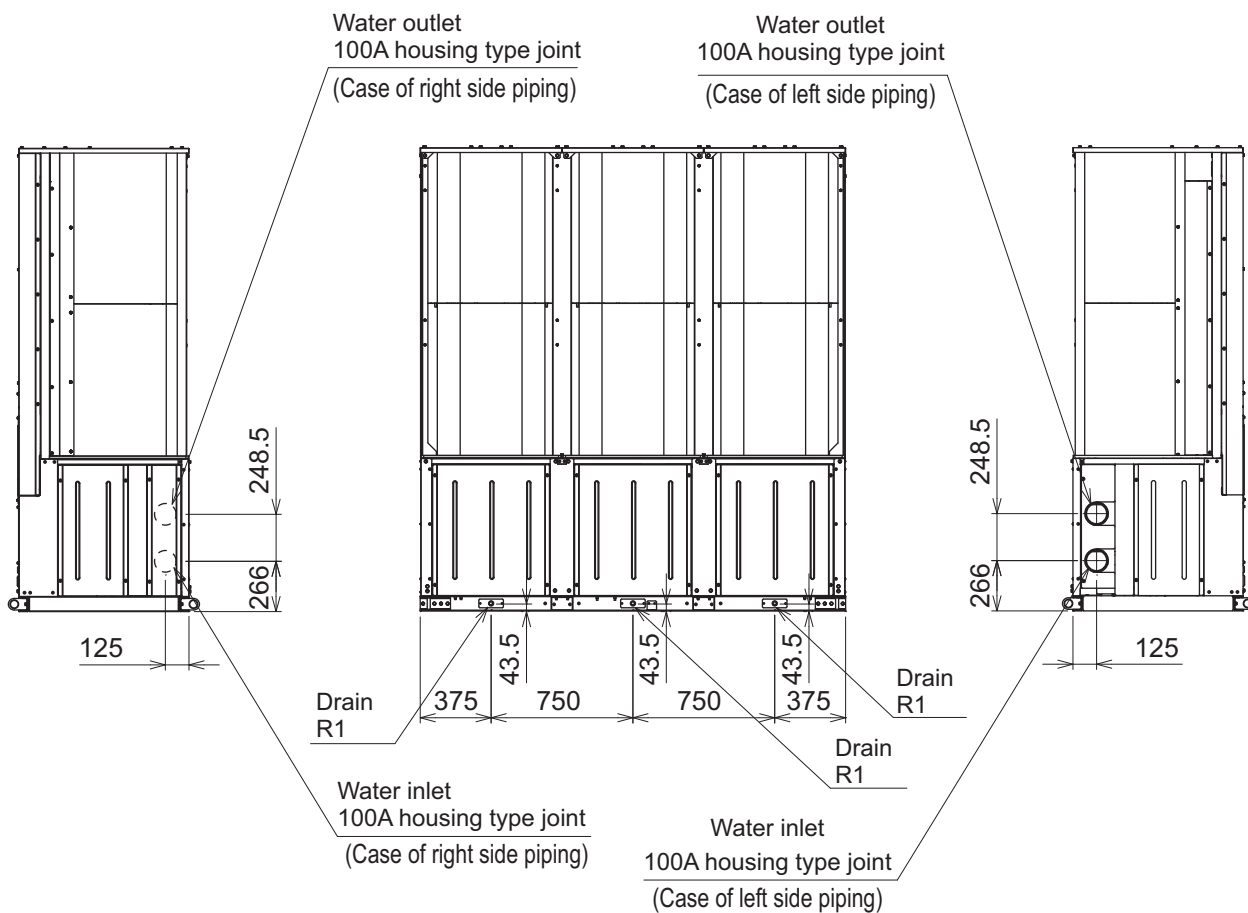

4. System Configurations

The system must be configured only by personnel certified by Mitsubishi Electric.

[1] Schematic Diagrams of Individual and Multiple Module Connection Systems

(1) Individual system

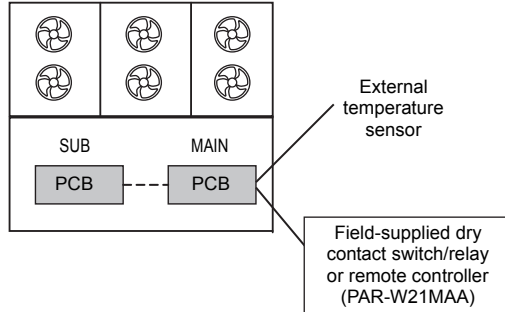

Refer to the sections "Switch Types and the Factory Settings" on the next page and "System configuration procedures: Individual system" (page 30) for further details.

(2) Multiple module connection system (2-6 modules)

* A group of module that consists of one main module and up to 5 sub modules is operated collectively by connecting an external water temperature sensor and a dry contact switch/relay to the main module.

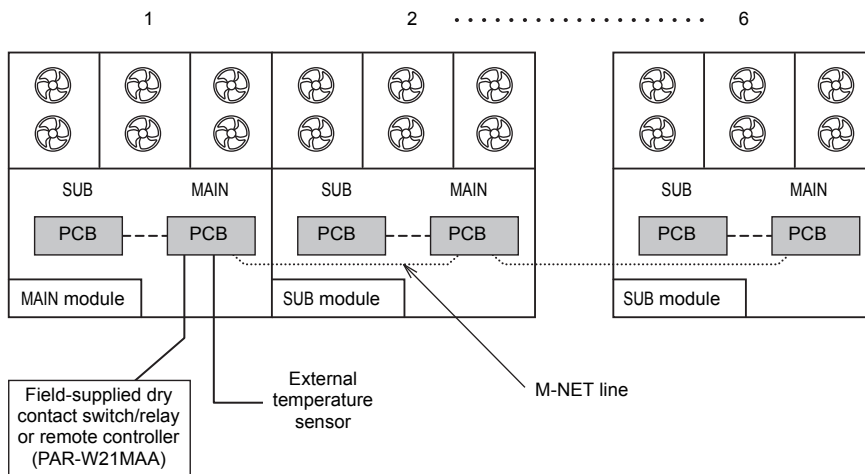

Refer to the sections "Switch Types and the Factory Settings" on the next page and "System configuration procedures: Multiple module connection system" (page 31) for further details.

[2] Switch Types and the Factory Settings

(1) Switch names and functions

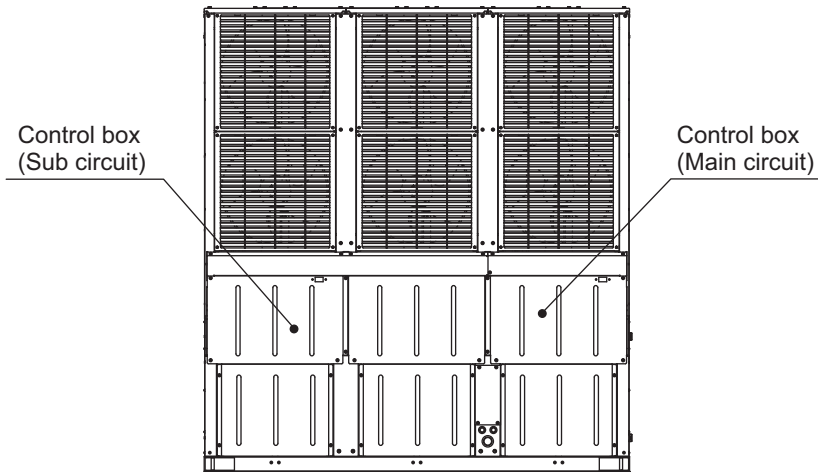

There are four main ways to set the settings as follows:

- ① Dip switches (SW1 - SW3, SW421)
- ② Dip switches used in combination with the push switches
- ③ Rotary switches
- ④ Slide switches

See below for how these switches are used to set certain items.

Different types of switches on the PCB

[Entire view of a PCB]

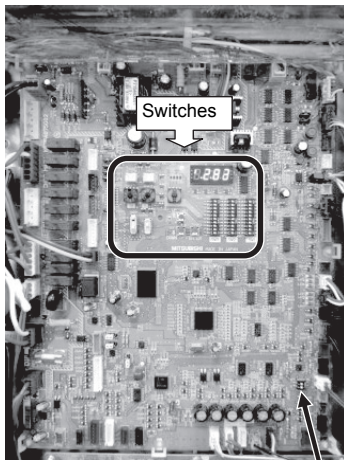

[Enlarged view of the switches]

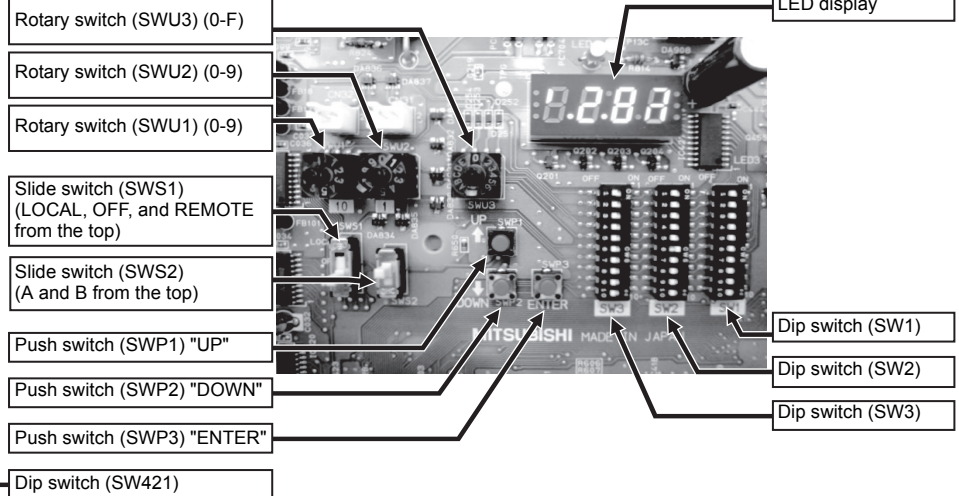

		Initial Setting					
		MAIN circuit	SUB circuit				
Rotary switch (SWU1)	Sets the 10's digit of the unit address (Multiple system).	"0"	"5"				
Rotary switch (SWU2)	Sets the 1's digit of the unit address (Multiple system).	"1"	"1"				
Rotary switch (SWU3)	Unused	"0"	"0"				
Slide switch (SWS1)	<table border="1" style="display: inline-table; vertical-align: middle;"> <tr> <td>LOCAL</td> <td rowspan="3">The action that the switch takes when set to a certain position depends on the type of system configuration (e.g., individual or multiple system)</td> </tr> <tr> <td>OFF</td> </tr> <tr> <td>REMOTE</td> </tr> </table>	LOCAL	The action that the switch takes when set to a certain position depends on the type of system configuration (e.g., individual or multiple system)	OFF	REMOTE	REMOTE	OFF (Unused)
LOCAL	The action that the switch takes when set to a certain position depends on the type of system configuration (e.g., individual or multiple system)						
OFF							
REMOTE							
Slide switch (SWS2)	Cooling/Heating switching (Only EAHV-P900YA) (Effective only when SWS1 is set to LOCAL.)	A	A (Unused)				
Push switch (SWP1)	Switches the display between the current value for a specific item. Increases value.	-	-				
Push switch (SWP2)	Switches the display between the current value for a specific item. Decreases value.	-	-				
Push switch (SWP3)	Enables the change of value. Saves the changed value.	-	-				
Dip switches (SW1-3)	Setting change or view the settings	-	-				
Dip switch (SW421)	Analog input type setting (Refer to Page 39)	-	(Unused)				

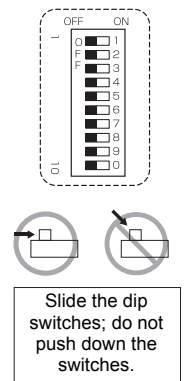

(2) Factory Switch Settings (Dip switch settings table)

SW	Function	Usage	Factory setting		OFF setting	ON setting	Setting timing					
			MAIN circuit	SUB circuit								
SW1	1	Settings change or view the settings	These switches are used for setting change with push switch SWP 1, 2 and 3.	OFF	OFF	The 7-segment LED display is changed.	Depends on the setting					
	2											
	3											
	4											
	5											
	6											
	7											
	8											
	9											
	10											
SW2	1	Model setting		Depends on the unit	-	Leave the setting as it is.	At a reset					
	2											
	3											
	4											
	5	Water-temperature control option	Selects either the external water temperature sensor or the built-in sensor to be used to control water temperature.	OFF	-	Built-in sensor on the unit	External water temperature sensor	At a reset				
	6	Model setting		OFF	-	Leave the setting as it is.		At a reset				
	7	Analog input setting	Allows or disallows the analog signals from a remote location.	OFF	-	Disallows the external analog signals.	Allows the external analog signals.	At a reset				
	8	Analog input signal switching	Selects either the water temperature or the capacity control ratio. (Effective only when SW2-7 is set to ON.)	OFF	-	Water temperature	Capacity control ratio	At a reset				
	9	Auto restart after power failure	Enables or disables the automatic restoration of operation after power failure (in the same mode as the unit was in before a power failure).	ON	-	An alarm will be issued when power is restored after a power outage. The alarm will be reset when the power is turned off and then turned back on.	Automatically restores operation after power failure.	Any time				
	10	Model setting		OFF	OFF	Leave the setting as it is.		Any time				
SW3	1	Analog input type setting	Selects analog input 4-20mA/0-10V/1-5V/2-10V. (Effective only when SW2-7 is set to ON.)	OFF	OFF	<table border="0"> <tr><td>1 / 2</td></tr> <tr><td>4-20mA : OFF OFF</td></tr> <tr><td>0-10V : ON OFF</td></tr> <tr><td>1-5V : OFF ON</td></tr> <tr><td>2-10V : ON ON</td></tr> </table>	1 / 2	4-20mA : OFF OFF	0-10V : ON OFF	1-5V : OFF ON	2-10V : ON ON	Any time
	1 / 2											
	4-20mA : OFF OFF											
	0-10V : ON OFF											
	1-5V : OFF ON											
	2-10V : ON ON											
	2											
	3	Display setting *	Switches the LED display of the control board. (Display is switched in the 3 second intervals.)	ON	ON	High pressure Low pressure	High pressure Low pressure Inlet water temperature Outlet water temperature Ambient temperature	Any time				
	4	Model setting		OFF	-	Leave the setting as it is.		At a reset				
	5											
6												
7												
8	Model setting		OFF	OFF	Leave the setting as it is.		Any time					
9	Model setting		OFF	-	Leave the setting as it is.		Any time					
10	Model setting		OFF	-	Leave the setting as it is.		Any time					

"-" in the table indicates that the function in the corresponding row will be disabled regardless of the actual switch setting. The factory setting for these items is OFF.

* LED display

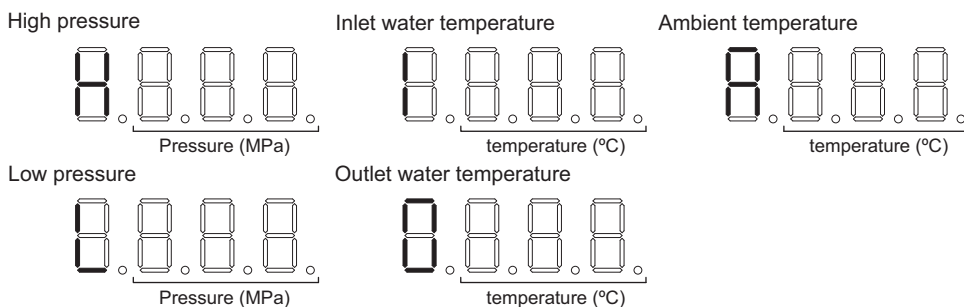

[3] Configuring the Settings

The settings must be set only by a qualified personnel.

<1> Making the settings

Use the LED display and the three push switches (SWP1 (↑), SWP2 (↓), and SWP3 (Enter)) to change the current settings on the circuit board and to monitor various monitored values.

(1) Setting procedures

Take the following steps to set the push switches SWP1 through SWP3. These switches must be set after the dip switch SW1 has been set.

① Normally a value of setting item appears on the display.

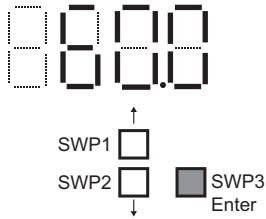

↓
Press SWP3 (Enter) to enable the configuration changes.

② The current setting value will blink.

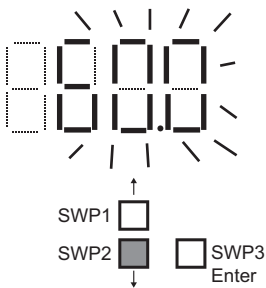

↓
The left figure shows that the current setting value is "60.0."
To decrease this value to 58.0, for example, press SWP2 (↓).
Press SWP1 (↑) to increase the value.

③ When the desired value is displayed (58.0 in the example at left), press SWP3 (Enter).

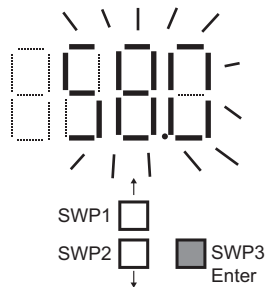

↓
The displayed value will stop blinking and stay lit.

A lit LED indicates that the new setting has been saved.

* Pressing SWP1 (↑) or SWP2 (↓) will change the blinking setting value, but the change will not be saved until SWP3 (Enter) is pressed.
Press and hold SWP1 (↑) or SWP2 (↓) for one second or longer to fast forward through the numbers.

(2) Table of settings items

Set the dip switch SW1 as shown in the table below to set the value for the items in the "Setting item" column.

No.	Dip switch setting (SW1) *1										Setting Item	Default	Notes
	■:ON □:OFF												
1				4	5	6		8	9	10	Maximum peak-demand capacity	100%	Range 60-100%
2	1			4			7	8		10	Peak-demand control start time	13:00	
3		2		4			7	8		10	Peak-demand control end time	13:00	
4	1			4					9	10	Setting temp 1 (Cooling mode) *2	7°C	Range 5-25°C
5	1					6			9	10	Setting temp 2 (Cooling mode) *2	20°C	Range 5-25°C
6		2		4					9	10	Setting temp 1 (Heating mode) *3	45°C	Range 30-55°C
7		2				6			9	10	Setting temp 2 (Heating mode) *3	55°C	Range 30-55°C
8	1	2		4			7	8		10	Setting water temp A at Heating ECO mode *3	55°C	Range 30-55°C
9			3	4			7	8		10	Setting outdoor temp A at Heating ECO mode *3	0°C	Range -30-50°C
10	1		3	4			7	8		10	Setting water temp B at Heating ECO mode *3	35°C	Range 30-55°C
11		2	3	4			7	8		10	Setting outdoor temp B at Heating ECO mode *3	25°C	Range -30-50°C
12					5		7	8		10	Setting water temp C at Heating ECO mode *3	45°C	Range 30-55°C
13	1				5		7	8		10	Setting outdoor temp C at Heating ECO mode *3	15°C	Range -30-50°C
14			3		5			8		10	Enable/disable schedule setting *4	0	Set to "1" to enable scheduled operation.
15			3	4				8		10	ON time 1 (at schedule mode without remote) *2	0:00	Cooling mode ON
16	1		3	4				8		10	OFF time 1 (at schedule mode without remote) *2	0:00	Cooling mode OFF
17		2	3	4				8		10	ON time 2 (at schedule mode without remote) *3	0:00	Heating mode ON
18	1	2	3	4				8		10	OFF time 2 (at schedule mode without remote) *3	0:00	Heating mode OFF
19	1	2			5		7	8		10	ON time 3 (at schedule mode without remote) *3	0:00	Heating ECO mode ON
20			3		5		7	8		10	OFF time 3 (at schedule mode without remote) *3	0:00	Heating ECO mode OFF
21	1	2		4					9	10	Thermo differential 1 (Cooling mode) *2	2°C	Range 0.2-5°C
22			3	4					9	10	Thermo differential 2 (Cooling mode) *2	2°C	Range 0.2-5°C
23	1		3	4					9	10	Thermo differential 1 (Heating mode) *3	2°C	Range 0.2-5°C
24		2	3	4					9	10	Thermo differential 2 (Heating mode) *3	2°C	Range 0.2-5°C
25					5	6		8		10	Drain pan heater operation outdoor temp	0°C	Range -40-20°C
26	1		3				7	8		10	Supplementary heater operation water temp *3	40°C	Range 0-55°C
27	1	2	3				7	8		10	Supplementary heater operation outdoor temp *3	-10°C	Range -30-50°C
28		2			5		7	8		10	Select a heating curve *3	1	0: 2-point system, 1: curve
29		2	3	4	5	6	7	8	9	10	Current time	-	
30	1		3	4	5	6	7	8	9	10	Month/Date setting	-	
31			3	4	5	6	7	8	9	10	Year setting	-	

*1: Do not apply undue force when changing the Dip switch settings as this may cause malfunctions.

*2: They are enabled during the cooling. (EAHV-P900YA, EACV-P900YA)

*3: They are enabled during the heating. (EAHV-P900YA, EAHV-P900YA-H)

*4: Disable the schedule setting when using the remote controller.

<2> System configuration

(1) System configuration procedures: Individual system

1. Set the dip switches on the MAIN circuit board.

Switch settings on the MAIN circuit

Set the dip switches (labeled A in the figure at right) that correspond to the items below, according to the local system.

- Water temperature control based on the external water temperature reading
- Analog signals from a remote location

Refer to "Dip switch settings table" (page 27) for further details.

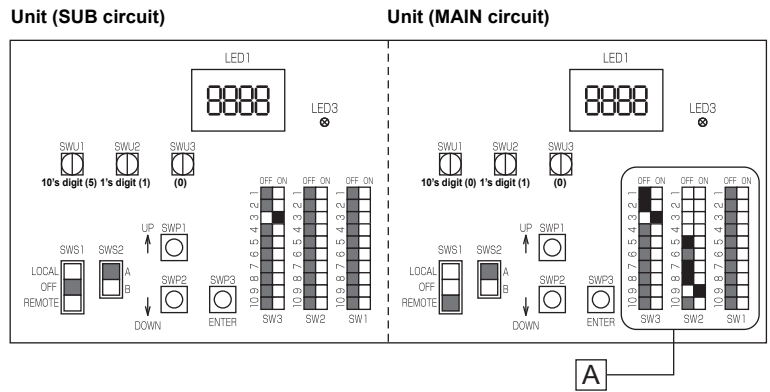

2. Switch on the power to the unit.

Check for loose or incorrect wiring, and then switch on the power to the unit.

When the power is switched on, the following codes will appear on the LED:

- [EEEE] will appear on LED1 in the MAIN circuit board (labeled A in the figure at right).
- [9999] will appear on LED1 in the SUB circuit board (labeled B in the figure at right).

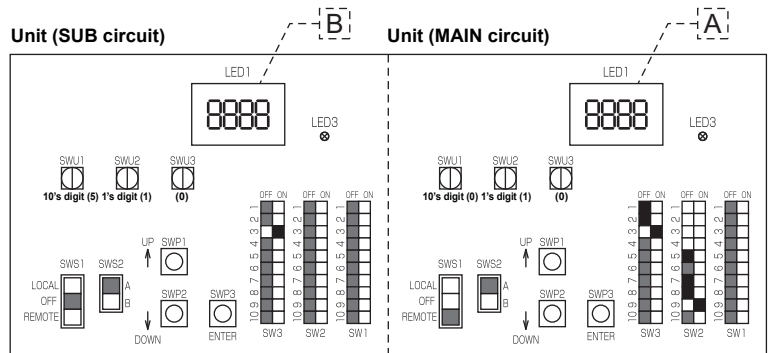

Within 50 seconds after the power is switched on, the following codes will appear on the LED:

- [****] will appear on LED1 in the MAIN circuit board (labeled A in the figure above).
- [0000]→[****] will appear on LED1 in the SUB circuit board (labeled B in the figure above).

****	Model
0000	EACV-P900YA
0001	EAHV-P900YA
0002	EAHV-P900YA-H

Then, the setting item "SW3-3" (page 27) will appear on the LED.

(2) System configuration procedures : Multiple modules connection system

1. Set the rotary switches.

System configuration diagram

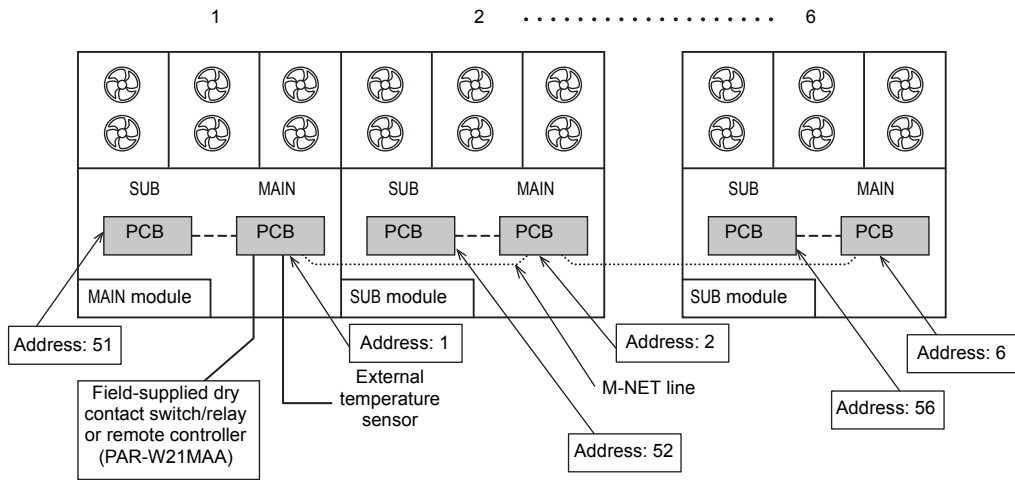

Setting the switches on the main module

Make sure the address of the MAIN circuit on the main module is set to "1" (labeled A in the figure at right) and that the address of the SUB circuit on the main module is set to "51" (labeled B in the figure at right).

The address of each SUB circuit should equal the sum of the MAIN circuit address on the same module and 50.

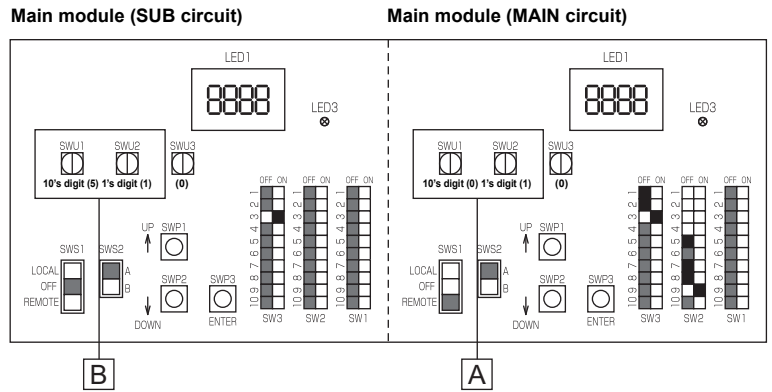

Setting the switches on all sub modules

MAIN circuit

(1) Set the MAIN circuit addresses with the rotary switches. (labeled A in the figure at right). Set the 10's digit with SWU1, and set the 1's digit with SWU2. Assign sequential addresses to the MAIN circuit on all sub modules starting with 2.

SUB circuit

(2) Set the SUB circuit addresses with the rotary switches (labeled B in the figure at right). Set the 10's digit with SWU1, and set the 1's digit with SWU2. Assign sequential addresses to the SUB circuit on all sub modules starting with 52.

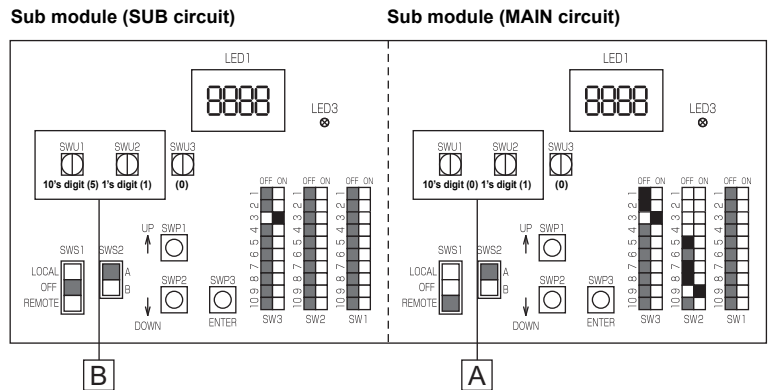

2. Switch on the power to the unit.

Check for loose or incorrect wiring, and then switch on the power to all modules.

When the power is switched on, the following codes will appear on the LED:

- [EEEE] will appear on LED1 in the MAIN circuit board.
- [9999] will appear on LED1 in the SUB circuit board.

Within 50 seconds after the power is switched on, the following codes will appear on the LED:

- [****] will appear on LED1 in the MAIN circuit board.
- [0000]→[****] will appear on LED1 in the SUB circuit board.

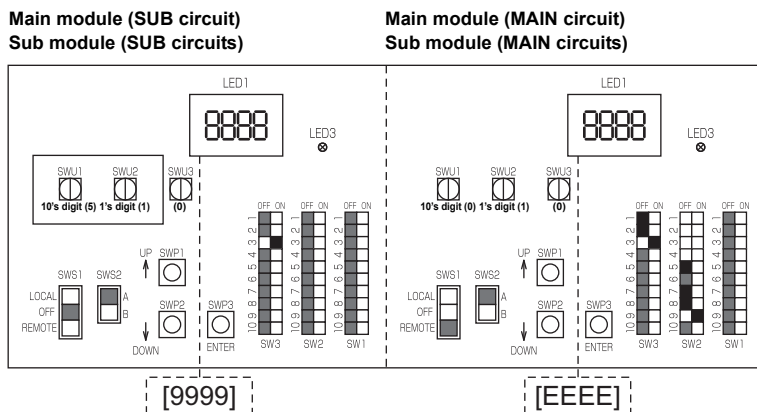

****	Model
0000	EACV-P900YA
0001	EAHV-P900YA
0002	EAHV-P900YA-H

Then, the setting item "SW3-3" (page 27) will appear on the LED.

3. Perform an initial setup on the main and sub modules

Perform the initial setup of all modules in accordance with the table below.

No.	Dip switch setting (SW1)								Setting Item	Main module	Sub module	Default	
	1	2	3	4	5	6	7	8					
1								8	10	Setting the multiple modules	1	1	0
2	1							8	10	Setting the main module	1	0	0
3		2						8	10	Setting the total number of modules	2-6	-	1
4			3					8	10	Setting the pump system *	0 or 1	0 or 1	1

*Change the setting to "0" in the multiple modules of the Standard piping type in one pump system and the Inside header piping type.

Slide switch (SWS1) settings

Individual system (SWS1 in the SUB circuit is ineffective.)

SWS1 Setting		Unit Operation	
MAIN circuit	SUB circuit	MAIN circuit	SUB circuit
LOCAL	-	Follows the input signal of the MAIN circuit	Follows the input signal of the MAIN circuit
OFF	-	Ignores the signal input	Ignores the signal input
REMOTE	-	Follows the input signal fed through a No-voltage contact interface	Follows the input signal of the MAIN circuit

Multiple system (SWS1 in the SUB circuit is ineffective.)

SWS1 Setting		Unit Operation			
Main module MAIN circuit	Sub module MAIN circuit	Main module MAIN circuit	Main module SUB circuit	Sub module MAIN circuit	Sub module SUB circuit
LOCAL	LOCAL	Follows the input signal of the MAIN circuit on the Main module	Follows the input signal of the MAIN circuit on the Main module	Follows the input signal of the MAIN circuit on the Sub module	Follows the input signal of the MAIN circuit on the Sub module
	OFF			Ignores the signal input	Ignores the signal input
	REMOTE			Follows the input signal of the MAIN circuit on the Main module	Follows the input signal of the MAIN circuit on the Main module
OFF	LOCAL	Ignores the signal input	Ignores the signal input	Follows the input signal of the MAIN circuit on the Sub module	Follows the input signal of the MAIN circuit on the Sub module
	OFF			Ignores the signal input	Ignores the signal input
	REMOTE				
REMOTE	LOCAL	Follows the input signal fed through a dry contact interface	Follows the input signal of the MAIN circuit on the Main module	Follows the input signal of the MAIN circuit on the Sub module	Follows the input signal of the MAIN circuit on the Sub module
	OFF			Ignores the signal input	Ignores the signal input
	REMOTE			Follows the input signal of the MAIN circuit on the Main module	Follows the input signal of the MAIN circuit on the Main module

Priority order of the water-temperature-setting-input-signal sources

Water temperature can be controlled by using the signals from the four types of input sources listed below. The setting for the item with higher priority will override the settings for the items with lower priorities. The water temperature will be controlled according to the temperature setting in the "Target water temperature" column that corresponds to a specific combination of the settings for the four items.

No-voltage contact input K04-K05 ON: Heating (EAHV-P900YA, EAHV-P900YA-H)

Priority 1	Priority 2	Priority 3	Priority 4	Priority 5			Target water temperature	Sensor that becomes active (when SW2-5 is set to ON) (*1)	
No-voltage contact input K07-K08	Analog input	Main board on the unit	No-voltage contact input K13-K15	Remote controller PAR-W21MAA					
Anti freeze		Schedule setting	Mode change	No remote controller	Manual setting	Schedule setting			
ON	Ineffective	Ineffective	Ineffective	-	Ineffective	Ineffective	30°C	TH3	
OFF	SW2-7: ON	Ineffective	Ineffective	-	Ineffective	Ineffective	Temperature setting for the analog signal input	TH15	
	SW2-7: OFF	When schedule has been set	Ineffective	-	Ineffective	Ineffective	Heating or Heating ECO	TH15	
			ON (Heating ECO)	-	Ineffective	Ineffective	Heating ECO	TH15	
		When no schedule has been set	OFF (Heating)	When no RC is used	-	-	-	Heating	TH15
				-	Anti freeze	-	-	30°C	TH3
				-	Heating ECO	-	-	Heating ECO	TH15
				-	Heating	-	-	Heating	TH15
				-	Cooling (*2)	-	-	Cooling	TH15
-	-	-	When schedule has been set (*3)	Target water temp is controlled according to the setting on the remote controller.	TH15				

*1 If SW2-5 is set to OFF, water temperature will be controlled by the built-in thermistor TH3 on the unit.

*2 This mode is disabled in EAHV-P900YA-H.

*3 EAHV-P900YA can also set Cooling.

No-voltage contact input K04-K05 OFF: Cooling (EAHV-P900YA, EACV-P900YA)

* When the operation mode is Cooling, K07-K08 (Anti freeze) and K13-K15 (Mode change) are disabled.

Priority 1	Priority 2	Priority 3			Target water temperature	Sensor that becomes active (when SW2-5 is set to ON) (*1)	
Analog input	Main board on the unit	Remote controller PAR-W21MAA					
	Schedule setting	No remote controller	Manual setting	Schedule setting			
SW2-7: ON	Ineffective	-	Ineffective	Ineffective	Temperature setting for the analog signal input	TH15	
SW2-7: OFF	When schedule has been set	-	Ineffective (Cooling)	Ineffective (Cooling)	Cooling	TH15	
		When no schedule has been set	When no RC is used	-	-	-	Cooling
	-		Anti freeze (*2)	-	-	30°C	TH3
	-		Heating ECO (*2)	-	-	Heating ECO	TH15
	-		Heating (*2)	-	-	Heating	TH15
	-		Cooling	-	-	Cooling	TH15
-	-	-	When schedule has been set (*3)	Target water temp is controlled according to the setting on the remote controller.	TH15		

*1 If SW2-5 is set to OFF, water temperature will be controlled by the built-in thermistor TH3 on the unit.

*2 This mode is disabled in EACV-P900YA.

*3 EAHV-P900YA can also set Heating or Heating ECO.

<3> Setting procedures

(1) Water-temperature setting

Different water temperature settings can be set for different modes.

Set the dip switches on the circuit board as follows to make the settings for the items described in this section.

Press the push switch SWP3 to enable the configuration changes.

Press the push switches SWP1 (↑) or SWP2 (↓) to increase or decrease the value.

When the desired value is displayed, press SWP3 to save the setting value.

Settings table

No.	Dip switch setting (SW1) ■:ON □:OFF										Setting Item	Initial value	Unit	Setting			Setting change from an optional remote controller (PAR-W21MAA) *1
	1	2	3	4	5	6	7	8	9	10				Increments	Lower limit	Upper limit	
1	1			4					9	10	Setting temp 1 (Cooling mode)	7	°C	0.1°C	5	25	Possible *2
2	1					6			9	10	Setting temp 2 (Cooling mode)	20	°C	0.1°C	5	25	Possible *3
3		2		4					9	10	Setting temp 1 (Heating mode)	45	°C	0.1°C	30	55	Possible *2
4		2				6			9	10	Setting temp 2 (Heating mode)	55	°C	0.1°C	30	55	Possible *3
5	1	2		4			7	8		10	Setting water temp A at Heating ECO mode	55	°C	0.1°C	30	55	Not possible
6			3	4			7	8		10	Setting outdoor temp A at Heating ECO mode	0	°C	0.1°C	-30	50	Not possible
7	1		3	4			7	8		10	Setting water temp B at Heating ECO mode	35	°C	0.1°C	30	55	Not possible
8		2	3	4			7	8		10	Setting outdoor temp B at Heating ECO mode	25	°C	0.1°C	-30	50	Not possible
9					5		7	8		10	Setting water temp C at Heating ECO mode	45	°C	0.1°C	30	55	Not possible
10	1				5		7	8		10	Setting outdoor temp C at Heating ECO mode	15	°C	0.1°C	-30	50	Not possible
11		2			5		7	8		10	Select a heating curve	1	-	0: 2-point system, 1: curve		Not possible	

*1 Temperature setting increments: 1°C

*2 No-voltage contact K10-K12: OFF

*3 No-voltage contact K10-K12: ON

Heating ECO (2-point system)

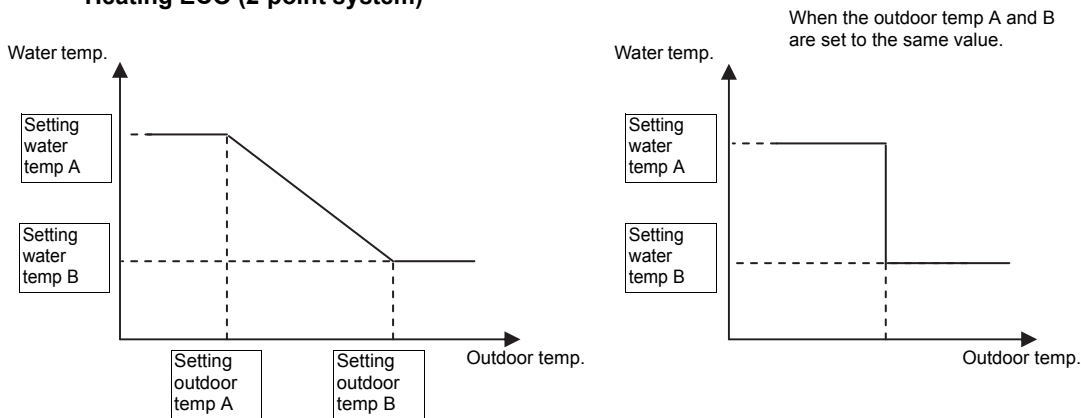

* Setting temp C cannot be used.

Heating ECO (Curve)

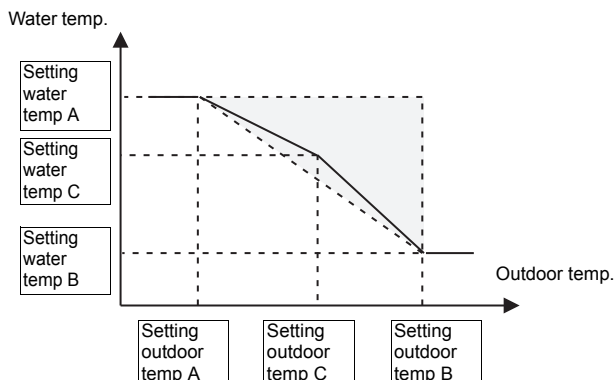

* Always use a value for setting C that is between setting value A and setting value B.

(2) Scheduled operation

Up to three sets of start/end times can be assigned for each day.

Note Disable the schedule setting when using the remote controller.

Note The operation schedule function will operate only when SWS1 is set to "REMOTE."

Set the dip switches on the circuit board as follows to make the settings for the items described in this section.

Press the push switch SWP3 to enable the configuration changes.

Press the push switches SWP1 (↑) or SWP2 (↓) to increase or decrease the value.

When the desired value is displayed, press SWP3 to save the setting value.

Settings table

No.	Dip switch setting (SW1) ■:ON □:OFF										Setting Item	Initial value	Unit	Setting		
	1	2	3	4	5	6	7	8	9	10				Increments	Lower limit	Upper limit
1			3		5			8		10	Enable/disable schedule setting	0	-	0: Disable, 1: Enable		
2			3	4				8		10	ON time 1 (Cooling mode without remote)	0000	Hour: minute	1 minute	0000	2359
3	1		3	4				8		10	OFF time 1 (Cooling mode without remote)	0000	Hour: minute	1 minute	0000	2359
4		2	3	4				8		10	ON time 2 (Heating mode without remote)	0000	Hour: minute	1 minute	0000	2359
5	1	2	3	4				8		10	OFF time 2 (Heating mode without remote)	0000	Hour: minute	1 minute	0000	2359
6	1	2			5		7	8		10	ON time 3 (Heating ECO mode without remote)	0000	Hour: minute	1 minute	0000	2359
7			3		5		7	8		10	OFF time 3 (Heating ECO mode without remote)	0000	Hour: minute	1 minute	0000	2359
8		2	3	4	5	6	7	8	9	10	Current time	-	Hour: minute	1 minute	0000	2359
9	1		3	4	5	6	7	8	9	10	Month/Date setting	-	Month: day	1 day	0101	1231
10			3	4	5	6	7	8	9	10	Year setting	-	Year	1 year	2000	2099

Note A mode (preset temperatures) can be selected for each operation time period. See the next page for how to make the settings.

[When the operation ON/OFF times do not overlap]

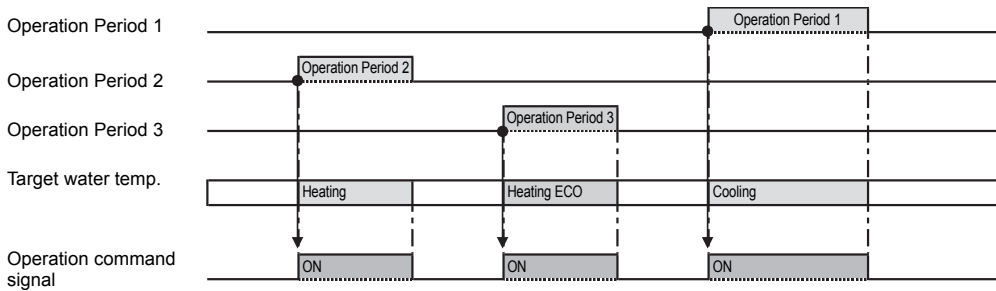

If two operation periods overlap, the settings for the period with a larger number will be ineffective.
 If ON time 1 and ON time 3 are set to the same value, the setting for ON time 3 will be ineffective.

[When operation period 1 and 2 overlap]

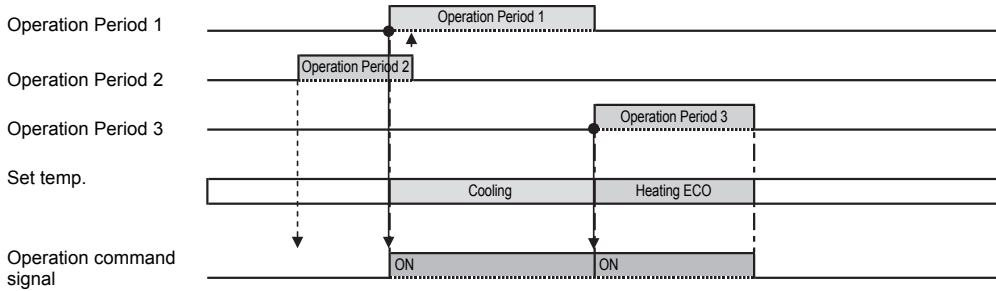

[When operation periods 1 and 3 overlap]

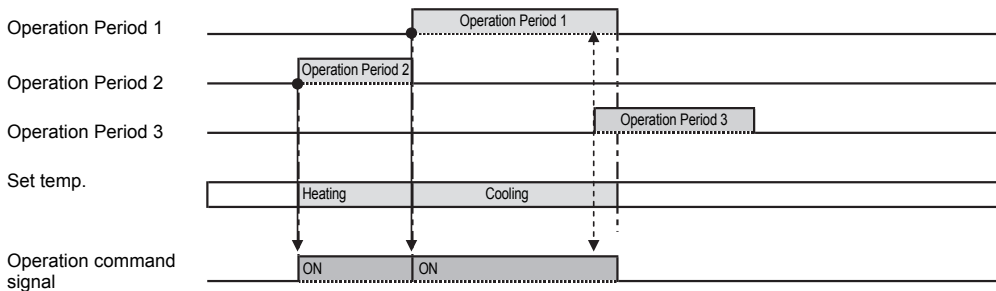

[When operation periods 2 and 3 overlap]

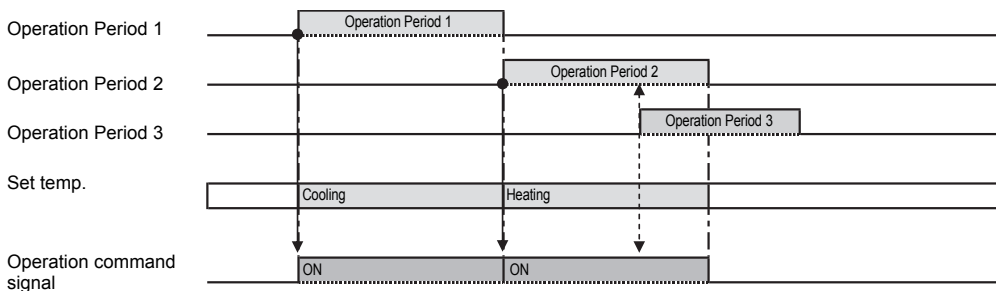

If "ON time1 - OFF time 1", "ON time 2 - OFF time 2", "ON time 3 - OFF time 3" overlap, the settings for the period with a larger number will be ineffective.

[When operation periods 1 and 2 overlap and operation periods 2 and 3 overlap]

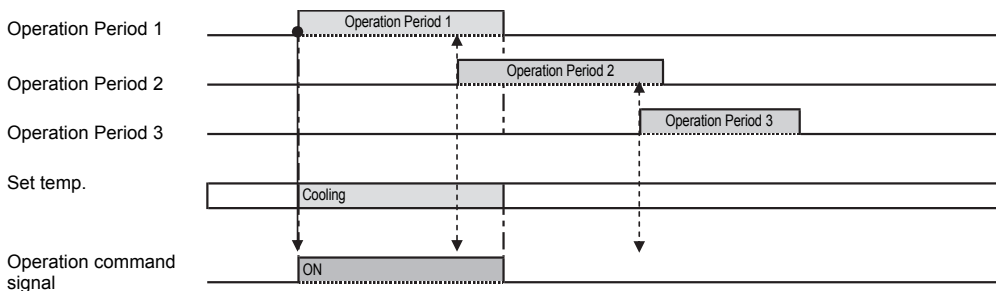

(3) Peak-demand control operation

Peak-demand control is a function used to control the power consumptions of the units during peak-demand hours.

The compressor's maximum operating frequency will be controlled according to the peak-demand control signal.

Set the dip switches on the circuit board as follows to make the settings for the items described in this section.

Press the push switch SWP3 to enable the configuration changes.

Press the push switches SWP1 (↑) or SWP2 (↓) to increase or decrease the value.

When the desired value is displayed, press SWP3 to save the setting value.

Settings table

No.	Dip switch setting (SW1) ■:ON □:OFF										Setting Item	Initial value	Unit	Setting			Setting change from an optional remote controller (PAR-W21MAA)
				4	5	6		8	9	10				Increments	Lower limit	Upper limit	
1				4	5	6		8	9	10	Maximum peak-demand capacity	100	%	1%	60	100	Not possible
2	1			4			7	8		10	Peak-demand control start time	1300	Hour: minute	1 minute	0000	2359	Not possible
3		2		4			7	8		10	Peak-demand control end time	1300	Hour: minute	1 minute	0000	2359	Not possible

(4) Remote water temperature or capacity control ratio setting input signal type

When SW2-7 is ON and SW2-8 is OFF, external analog signals can be used to set the water temperatures.

When SW2-7 and SW2-8 are ON, external analog signals can be used to set the capacity control ratio.

Analog input type can be selected from the following four types:

4-20 mA

0-10 V

1-5 V

2-10 V

Select SW3-1 and SW3-2 to set the type of analog input signal from a remote location.

Set the dip switches on the circuit board as follows to change the settings.

	SW421-1	SW421-2	SW3-1	SW3-2
4-20 mA	ON	ON	OFF	OFF
0-10 V	OFF	OFF	ON	OFF
1-5 V	OFF	ON	OFF	ON
2-10 V	OFF	OFF	ON	ON

*Incorrectly setting SW421 may cause damage to the circuit board.

(5) Setting the water temperature using analog signal input

When dip switch SW2-7 is set to ON (Enable external input) and SW2-8 is set to OFF, the target water temperature varies with the preset temperatures A and B and the type of analog input signal.

Set the dip switches on the circuit board as follows to make the settings for the items described in this section.

Press the push switch SWP3 to enable the configuration changes.

Press the push switches SWP1 (↑) or SWP2 (↓) to increase or decrease the value.

When the desired value is displayed, press SWP3 to save the setting value.

Settings table

No.	Dip switch setting (SW1) ■:ON □:OFF										Setting Item	Initial value	Unit	Setting			Setting change from an optional remote controller (PAR-W21MAA)
	1	2	3	4	5	6	7	8	9	10				Increments	Lower limit	Upper limit	
1		2		4	5	6		8		10	Preset temp. A (Cooling)	5	°C	1°C	5	25	Not possible
2	1	2		4	5	6		8		10	Preset temp. B (Cooling)	25	°C	1°C	5	25	Not possible
3	1						7	8		10	Preset temp. A (Heating)	30	°C	1°C	30	55	Not possible
4		2					7	8		10	Preset temp. B (Heating)	55	°C	1°C	30	55	Not possible

* Due to the resistance of the wire that is connected to the analog input, the preset temperature may not properly be sent. If this is the case, check the current value of the analog input, and adjust the output value of the connected signal output device. Refer to the tables below for how to display the value of the analog input.

No.	Dip switch setting (SW1) ■:ON □:OFF										Monitorable items	Unit
1		2					7				Current value (4-20 mA)	mA
2	1	2					7				SV voltage value (1-5 V)	V
3			3				7				10V voltage value (0-10 V or 2-10 V)	V

- When the water temperature setting input signal type is 4-20 mA
 - External analog input signal of 6 mA: Preset temp. A
 - External analog input signal of 18 mA: Preset temp. B
 - External analog input signal of between 6 and 18 mA: the preset temperature will be linearly interpolated.

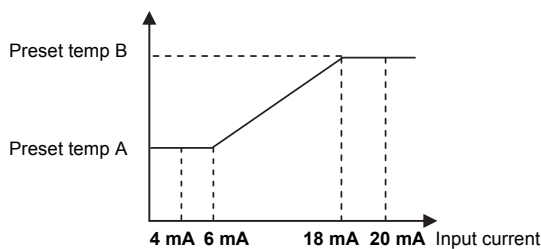

- When the water temperature setting input signal type is 0-10 V
 - External analog input signal of 1 V: Preset temp. A
 - External analog input signal of 9 V: Preset temp. B
 - External analog input signal of between 1 and 9 V: the preset temperature will be linearly interpolated.

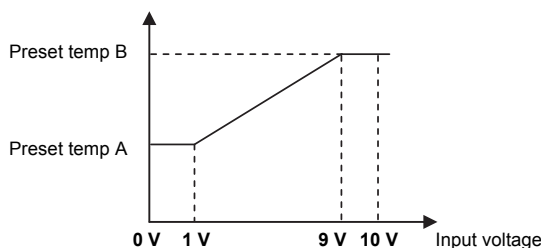

- When the water temperature setting input signal type is 1-5 V

- External analog input signal of 1.5 V: Preset temp. A
- External analog input signal of 4.5 V: Preset temp. B
- External analog input signal of between 1.5 and 4.5 V: the preset temperature will be linearly interpolated.

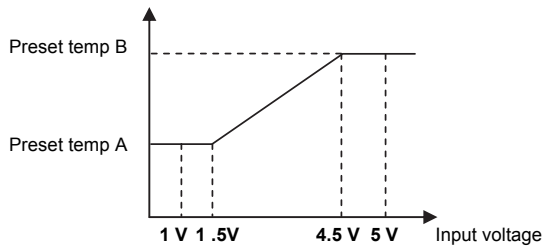

- When the water temperature setting input signal type is 2-10 V

- External analog input signal of 3 V: Preset temp. A
- External analog input signal of 9 V: Preset temp. B
- External analog input signal of between 3 and 9 V: the preset temperature will be linearly interpolated.

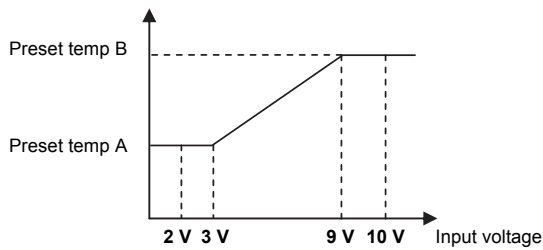

(6) Setting the capacity control ratio using analog signal input

When dip switch SW2-7 is set to ON (Enable external input) and SW2-8 is set to ON, the capacity control ratio varies with the type of analog input signal.

- When the water temperature setting input signal type is 4-20 mA
 - External analog input signal of 6 mA: 0%
 - External analog input signal of 18 mA: 100%
 - External analog input signal of between 6 and 18 mA: the percent will be linearly interpolated.

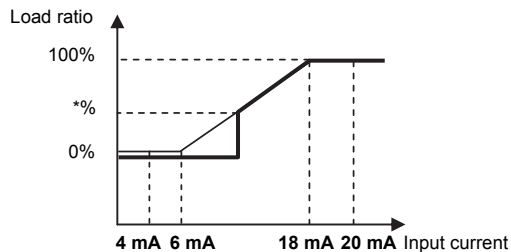

- When the water temperature setting input signal type is 0-10 V
 - External analog input signal of 1 V: 0%
 - External analog input signal of 9 V: 100%
 - External analog input signal of between 1 and 9 V: the percent will be linearly interpolated.

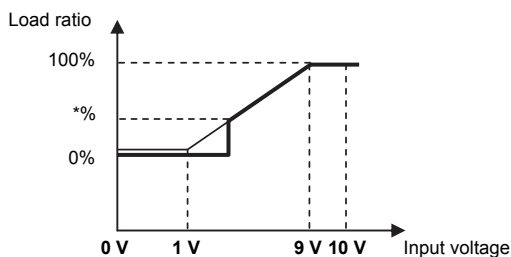

- When the water temperature setting input signal type is 1-5 V
 - External analog input signal of 1.5 V: 0%
 - External analog input signal of 4.5 V: 100%
 - External analog input signal of between 1.5 and 4.5 V: the percent will be linearly interpolated.

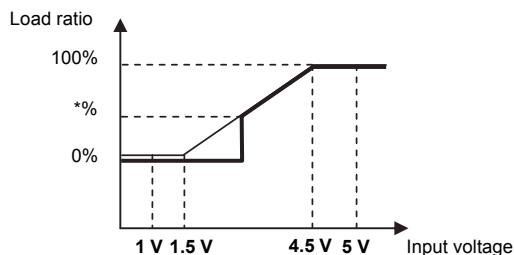

- When the water temperature setting input signal type is 2-10 V

- External analog input signal of 3 V: 0%
- External analog input signal of 9 V: 100%
- External analog input signal of between 3 and 9 V: the percent will be linearly interpolated.

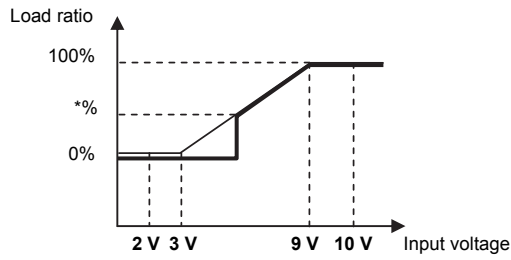

*%: When the compressor frequency drops below 16 Hz, the compressor stops.

The frequency value that causes the compressor to stop varies depending on the outside temperature and water temperature.

(7) Setting the supplementary heater signal output conditions

A temperature at which the signal output to operate supplementary heaters can be selected.

Supplementary heater signal output conditions

The operation command signal is ON and at least one of the following two conditions is met.

- 1 Water-temperature control option (SW2-5) is set to OFF, the inlet water temperature drops below a set water temperature, and the outdoor temperature drops below a set outdoor temperature.
- 2 Water-temperature control option (SW2-5) is set to ON, the external water temperature sensor reading (TH15) drops below a set water temperature, and the outdoor temperature drops below a set outdoor temperature.

The supplementary heater signal is output from K51-K52.

Supplementary heater signal output stop conditions

The operation command signal is OFF or at least one of the following two conditions is met.

- 1 The inlet water temperature is at or above a set water temperature +2°C or the outdoor temperature is at or above a set outdoor temperature +2°C.
- 2 External water temperature sensor reading (TH15) is at or above a set water temperature +2°C.

Set the dip switches on the circuit board as follows to make the settings for the items described in this section.

Press the push switch SWP3 to enable the configuration changes.

Press the push switches SWP1 (↑) or SWP2 (↓) to increase or decrease the value.

When the desired value is displayed, press SWP3 to save the setting value.

Settings table

No.	Dip switch setting (SW1) ■:ON □:OFF										Setting Item	Initial value	Unit	Setting			Setting change from an optional remote controller (PAR-W21MAA)
	1	2	3	4	5	6	7	8	9	10				Increments	Lower limit	Upper limit	
1	1		3				7	8		10	Supplementary heater operation water temp	40	°C	0.1°C	0	55	Not possible
2	1	2	3				7	8		10	Supplementary heater operation outdoor temp	-10		0.1°C	-30	50	Not possible

(8) Setting the drain pan heater signal output condition

A temperature at which the signal output to operate drain pan heaters can be selected.

Drain pan heater signal output condition

The following condition is met.

The outdoor temperature drops below a set outdoor temperature.

The drain pan signal is output from K63-K64.

Drain pan heater signal output stop condition

The following condition is met.

The outdoor temperature is at or above a set outdoor temperature +2°C.

Set the dip switches on the circuit board as follows to make the settings for the items described in this section.

Press the push switch SWP3 to enable the configuration changes.

Press the push switches SWP1 (↑) or SWP2 (↓) to increase or decrease the value.

When the desired value is displayed, press SWP3 to save the setting value.

Settings table

No.	Dip switch setting (SW1) ■:ON □:OFF										Setting Item	Initial value	Unit	Setting			Setting change from an optional remote controller (PAR-W21MAA)
					5	6		8		10				Increments	Lower limit	Upper limit	
1					5	6		8		10	Drain pan heater operation outdoor temp	0	°C	1°C	-40	20	Not possible

5. Electrical Wiring Installation

[1] Main Power Supply Wiring and Switch Capacity

Schematic Drawing of Wiring (Example)

(A): Switch (with current breaking capability)

(B): Current leakage breaker

(C): Unit

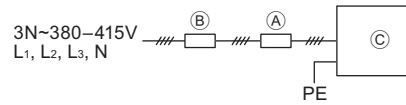

Main power supply wire size, switch capacities, and system impedance

Model	Minimum wire thickness (mm ²)			Current leakage breaker	Local switch (A)		No-fuse breaker (A)	Max. Permissible System Impedance
	Main cable	Branch	Ground		Capacity	Fuse		
EACV/EAHV-P900YA	25	-	25	75 A 100 mA 0.1 sec. or less	75	75	75	0.12 Ω

1. Use a dedicated power supply for each unit. Ensure that each unit is wired individually.
2. When installing wiring, consider ambient conditions (e.g., temperature).
3. The wire size is the minimum value for metal conduit wiring. If voltage drop is a problem, use a wire that is one size thicker.
Make sure the power-supply voltage does not drop more than 5%.
4. Specific wiring requirements should adhere to the wiring regulations of the region.
5. Power supply cords of appliances shall not be lighter than polychloroprene sheathed flexible cord (design 60245 IEC57).
6. A switch with at least 3 mm contact separation in each pole shall be provided by the Air Conditioner installer.
7. Do not install a phase advancing capacitor on the motor. Doing so may damage the capacitor and result in fire.

⚠ Warning:

- Be sure to use specified wires and ensure no external force is imparted to terminal connections. Loose connections may cause overheating and fire.
- Be sure to use the appropriate type of overcurrent protection switch. Note that overcurrent may include direct current.

⚠ Caution:

- Some installation sites may require an installation of an earth leakage breaker for the inverter. If no earth leakage breaker is installed, there is a danger of electric shock.
- Only use properly rated breakers and fuses. Using a fuse or wire of the wrong capacity may cause malfunction or fire.

Note:

- This device is intended for the connection to a power supply system with a maximum permissible system impedance shown in the above table at the interface point (power service box) of the user's supply.
- Ensure that this device is connected only to a power supply system that fulfills the requirements above. If necessary, consult the public power supply company for the system impedance at the interface point.
- This equipment complies with IEC 61000-3-12 provided that the short-circuit power S_{SC} is greater than or equal to $S_{SC} (*2)$ at the interface point between the user's supply and the public system. It is the responsibility of the installer or user of the equipment to ensure, in consultation with the distribution network operator if necessary, that the equipment is connected only to a supply with a short-circuit power S_{SC} greater than or equal to $S_{SC} (*2)$.

$S_{SC} (*2)$

S_{SC} (MVA)
4.74

Control cable specifications

Remote controller cable	Size	0.3 - 1.25 mm ² (Max. 200 m total)*2
	Recommended cable types	CVV
M-NET cable between units	Size	Min. 1.25 mm ² (Max. 120 m total)
	Recommended cable types	Shielded cable CVVS, CPEVS or MVVS
External input wire size		Min. 0.3 mm ²
External output wire size		1.25 mm ²

*1 Use a CVVS or CPEVS cable (Max. total length of 200 m) if there is a source of electrical interference near by (e.g., factory) or the total length of control wiring exceeds 120 m.

*2 When the wiring length exceeds 10 m, use field-supplied wire of 1.25 mm².

[2] Cable Connections

<1> Schematic Diagram of a Unit and Terminal Block Arrangement

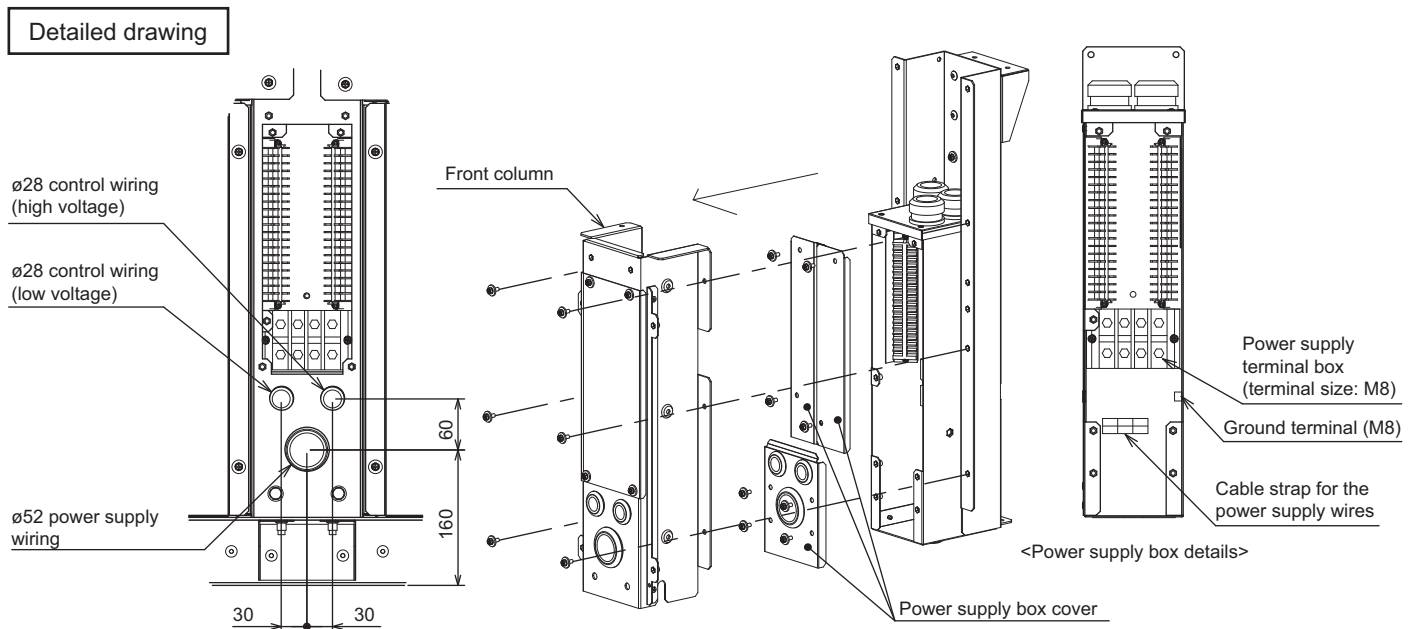
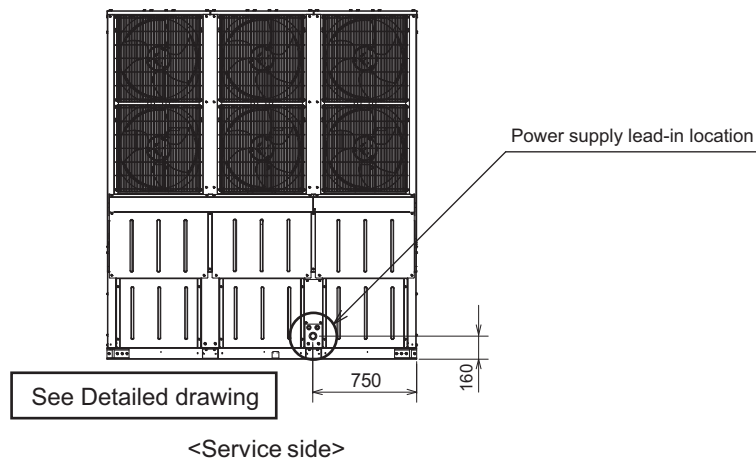

- (1) Remove the front column and power supply box cover.
- (2) Wire the power supply and control wires. The power supply box is covered with a bush with membrane. Cut the bush with membrane before connecting wires to the terminal box.
- (3) Fasten the power supply wires by the cable strap.
- (4) Secure the cable conduit, and then waterproof the area around the pipe with silicon, etc.
- (5) Reattach the power supply box cover and front column.

<2> Precautions when fastening screws

- * Faulty contacts due to loose screws may cause overheating and fire.
- * Using the circuit board while it is damaged may cause overheating and fire.

① Screw fastening torque

Power supply terminal block (TB4)...M8 screw: **10 to 13.5 N·m**

Use the following methods to check that the screws have been fastened.

1. Check that the spring washer is in a parallel position.

* If the screw is biting into the washer, simply fastening the screw to the specified torque cannot determine whether it has been installed properly.

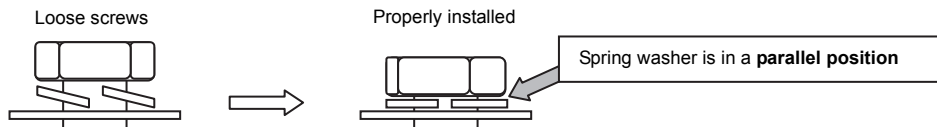

2. Check that the wiring does not move at the screw terminal.

- ② Take extra care not to ruin the screw thread due to fastening the screw at an angle.
* To prevent fastening the screw at an angle, install the round terminals so they are back to back.
- ③ After fastening the screw, use a permanent marker to tick off the screw head, washer and terminal.

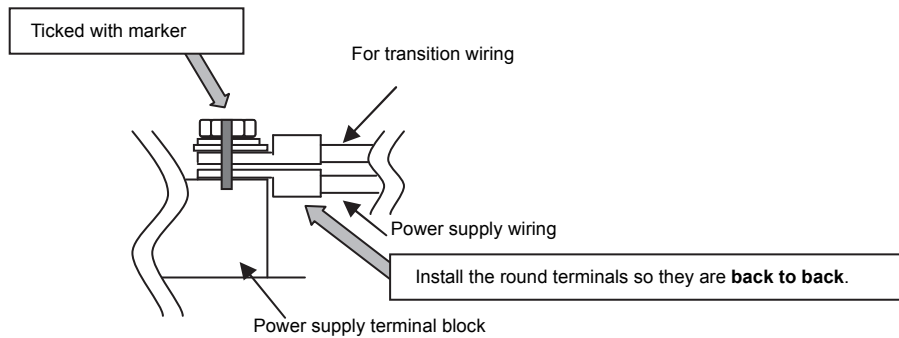

Important: Power supply cables larger than 25 mm² in diameter are not connectable to the power supply terminal block (TB4). Use a pull box to connect them.

<3> Installing the conduit tube

- Always use a conduit to run the power supply wiring.
- Select the conduit size based on the hole.
- The cable conduits must be prepared locally.
- Do not store the 24VDC or less low-voltage circuit and 100VAC or higher main circuit and control circuit cables in the same multi-core cable, or bundle them together.
- Attach cable conduits securely to the foundation, etc. to ensure that excessive loads are not applied to the power supply terminal box.
- Seal the area around the cable conduit connection to ensure that no water penetrates the cable conduit connection port.

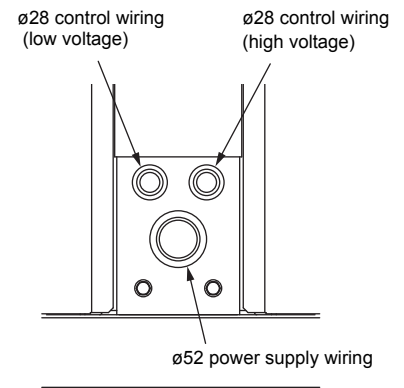



EAHV-P900YA(-H)(-N)(-BS)/EACV-P900YA(-N)(-BS) ELECTRICAL WIRING DIAGRAM

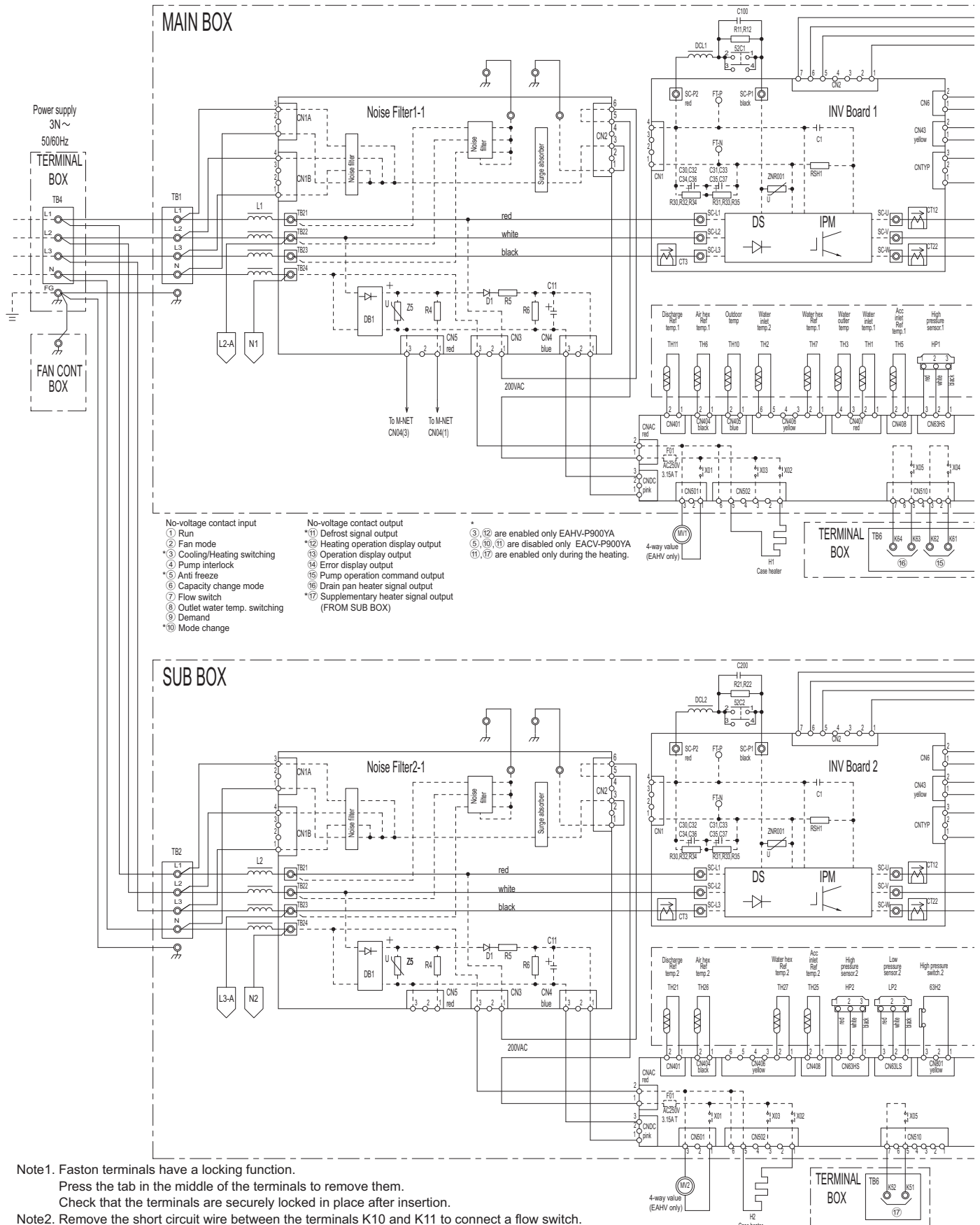

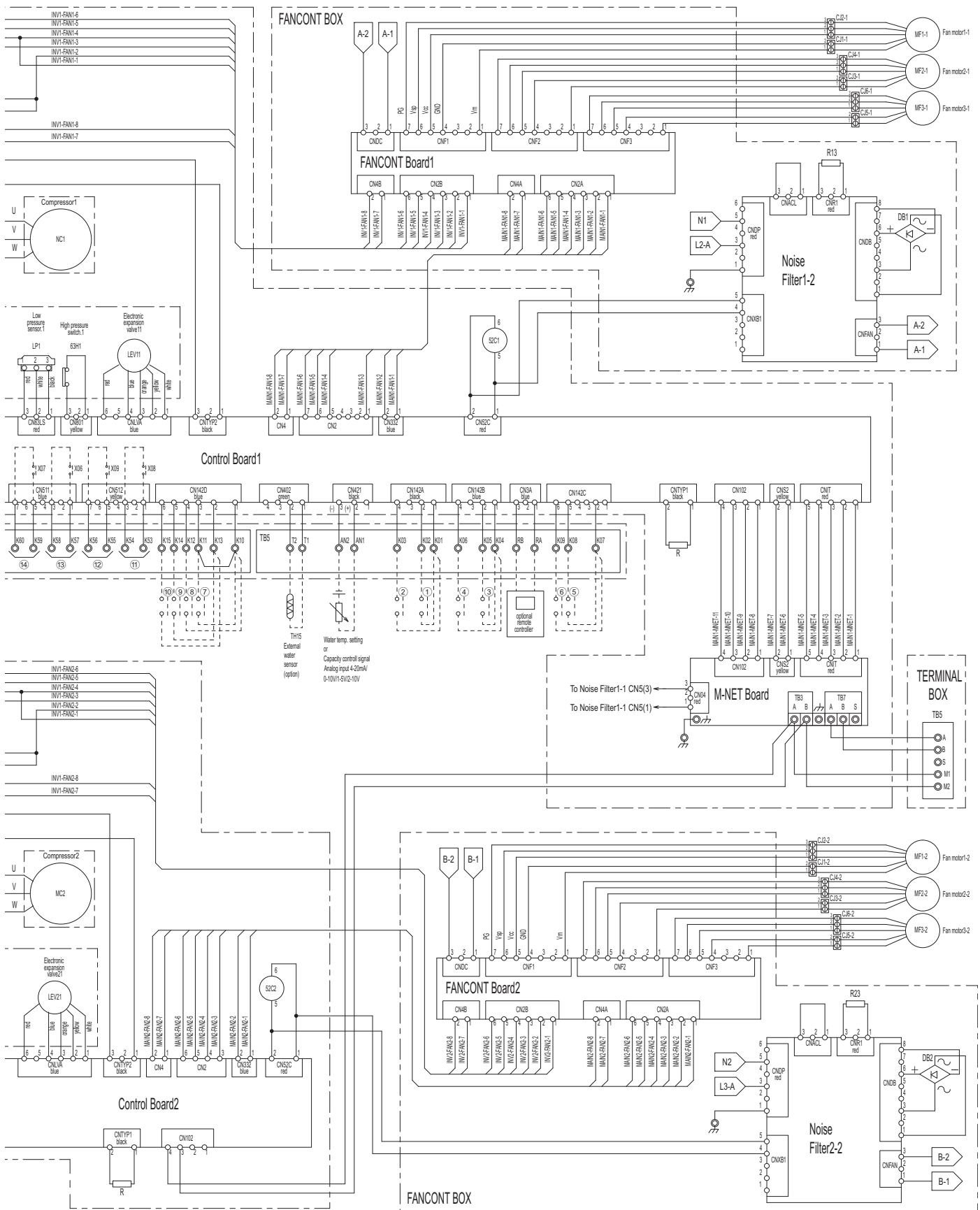

- Note7. Leave a space of at least 5 cm between the low voltage external wiring (No-voltage contact input and remote controller wiring) and wiring of 100V or greater. Do not place them in the same conduit tube or cabyre cable as this will damage the circuit board.
- Note8. When cabyre cable is used for the control cable wiring, use a separate cabyre cable for the following wiring.
Using the same cabyre cable may cause malfunctions and damage to the unit.
- Optional remote controller wiring
 - No-voltage contact input wiring
 - No-voltage contact output wiring
 - Analog input wiring
- Note9. Use a contact that takes 12VDC 1mA for No-voltage contact input.

FAN control (front view)

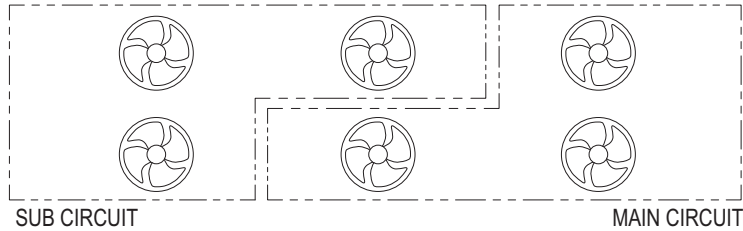

Inside of the control box (front view)

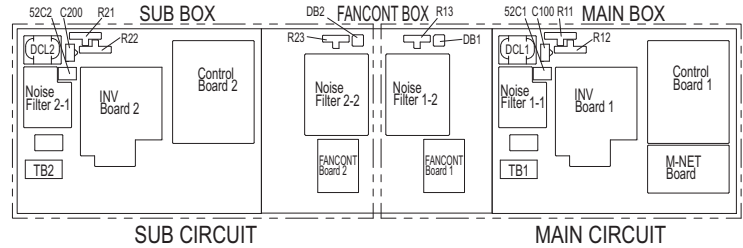

Error Codes

No.	Error code	Error type	Error reset *1
1	1102	Discharge temperature fault	○
2	1138	Hot water abnormal rise	○
3	1176	Discharge SH fault	○
4	1189	ACC inlet SH fault	○
5	1301	Low pressure fault	○
6	1302,1303	High pressure fault	○
7	1503	Cold water abnormal drop	○
8	1510	Gas leak fault	○
9	1512	Low evaporation temperature fault	○
10	2500	Water supply cutoff (Flow switch)	○
11	2501,2550	Water supply cutoff (Sensor)	○
12	4102	Open phase	×
13	4106	Power supply fault *2	○
14	4115	Power supply frequency fault	×
15	4116	Fan motor fault	○
16	4122	Fan interlock fault	○
17	4126	Analog input error	—
18	4220	Inverter bus voltage fault	○
19	4230	Inverter overheat protection fault	○
20	4240	Inverter overload protection	○
21	4250	IPM error(inclusive)/overcurrent relay	○
22	5101	Water inlet temp 1 thermistor error(TH1)	○
23	5102	Water inlet temp 2 thermistor error(TH2)	○
24	5103	Water inlet temp 3 thermistor error(TH3)	○
25	5105	ACC inlet refrigerant temperature thermistor error(TH5/TH25)	○
26	5106	Air heat exchanger refrigerant thermistor error(TH6/TH26)	○
27	5107	Water heat exchanger refrigerant thermistor error(TH7/TH27)	○
28	5110	Outdoor temperature thermistor error(TH10)	○
29	5111	Discharge refrigerant temperature thermistor error(TH11/TH21)	○
30	5114	THHS sensor/Circuit fault	○
31	5115	External water sensor fault	○
32	5201	High pressure sensor fault	○
33	5202	Low pressure sensor fault	○
34	5301	ACCT sensor fault/Circuit fault	○
35	0403	Serial communication error	○
36	6500	Communication error between the MAIN and SUB units	—
37	6600		×
38	6602		—
39	6603	Communication error between the MAIN and SUB units	—
40	6606	(Simple multiple unit control)	—
41	6607		—
42	6831	Remote controller signal reception error 1	—
43	6832	Remote controller signal transmission error	—
44	6834	Remote controller signal reception error 2	—
45	6833	Remote controller over current	×
46	7113,7117	Model setting error	×

*1. Definition of symbols in the "Error reset" column.

- ... Errors that can be reset
- ×
- ... Errors that will be automatically reset after the cause of the error is removed

*2. Power supply fault can be detected only when the switch setting "Automatic recovery after power supply fault" on the unit is set to "Disable." (The default setting is "Enable.")

Display setting(Control board display *)

SW3-3:OFF	SW3-3:ON
High pressure	High pressure
Low pressure	Low pressure
	Inlet water temperature
	Outlet water temperature
	Ambient temperature

* Display settings can be either of the MAIN BOX and the SUB box.
Display is switched in the 3 second intervals.

When using a local controller, refer to the table below for the types of input/output signals that are available and the operations that correspond to the signals.

External Input/Output

Input type	Dry contact		ON (Close)	OFF (Open)	Terminal block
	(a) UNIT OPERATION	Run/Stop	The unit will go into operation when the water temperature drops below the preset temperature.	The unit will stop except when the unit is in the Anti-Freeze mode.	TB5 K01-K02
(b) MODE CHANGE * EAHV-P900YA EAHV-P900YA-H	Heating ECO/Heating	Heating ECO mode (EAHV-P900YA: When "COOLING/HEATING SWITCHING" contact (item (j) below) is ON, this mode is enabled.)	Heating mode (EAHV-P900YA: When "COOLING/HEATING SWITCHING" contact (item (j) below) is ON, this mode is enabled.)	TB6 K13-K15	
(c) CAPACITY CHANGE MODE	COP priority/ Capacity priority	The unit will operate in the energy-efficient mode (COP priority mode).	The unit will operate at the maximum capacity setting (Capacity priority mode).	TB5 K07-K09	
(d) FAN MODE	Forced/Normal	When the outdoor temperature is 5°C or less, the fan will remain in operation after the compressor has stopped.	The fan will stop when the compressor stops.	TB5 K01-K03	
(e) ANTI FREEZE * EAHV-P900YA EAHV-P900YA-H	On/Off	The unit will operate in the Anti-Freeze mode (with the target temperature 30°C) when the contact status of (a) "UNIT OPERATION" is "Stop" OR the ON/OFF button on the remote controller is turned off.	The unit will operate according to the status of the "UNIT OPERATION" contact (item (a) above) or the ON/OFF command from the remote controller.	TB5 K07-K08	
(f) FLOW SWITCH	Normal/Error	The unit is allowed to operate.	The unit will not operate.	TB6 K10-K11	
(g) PUMP INTERLOCK	Normal/Error	The unit is allowed to operate.	The unit will not operate.	TB5 K04-K06	
(h) PEAK-DEMAND CONTROL	On/Off	The unit will operate at or below the maximum capacity level that was set for the Peak-demand control setting.	The unit will operate at or below the maximum capacity setting for either "Capacity Priority Mode" or "COP Priority Mode" that was selected for item (c) "CAPACITY CHANGE MODE" above.	TB6 K13-K14	
(i) OUTLET WATER TEMP SWITCHING	2nd/1st	Setting temp 2 (Refer to page 35 Settings table)	Setting temp 1 (Refer to page 35 Settings table)	TB6 K10-K12	
(j) COOLING/HEATING SWITCHING * EAHV-P900YA	Heating/ Cooling	Heating mode	Cooling mode	TB5 K04-K05	
Analog					Terminal block
Input type		Action			
(k) WATER TEMP SETTING/CAPACITY CONTROL SIGNAL		Water temperature or capacity control signal can be set by using the external analog input to the CN421 on the MAIN circuit board. One analog input type can be selected from the following types: 4-20 mA, 1-5 V, 0-10 V, or 2-10 V. * Use a 4-20 mA signal output device with insulation.			AN1(+)-AN2(-)
(l) EXTERNAL WATER SENSOR (optional)		-			TB5 T1-T2
Output type	Contact type		Conditions in which the contact closes (turns on)	Conditions in which the contact opens (turns off)	Terminal block
	(m) ERROR INDICATOR	Close/Open	The unit has made an abnormal stop.	During normal operation	TB6 K59-K60
(n) OPERATION INDICATOR	Close/Open	The "UNIT OPERATION" contact (item (a) above) or the ON/OFF button on the remote controller is ON.	The "UNIT OPERATION" contact (item (a) above) or the ON/OFF button on the remote controller is OFF.	TB6 K57-K58	
(o) PUMP OPERATION COMMAND	Close/Open	The pump will operate according to the status of the "UNIT OPERATION" contact or the ON/OFF button on the remote controller button.	Under all conditions other than the ones listed on the left	TB6 K61-K62	
(p) SUPPLEMENTARY HEATER SIGNAL	Close/Open	Water and outdoor temperature has dropped below a setting water temperature and a set outdoor temperature.	Water temperature is at or above a set water temperature +2°C or the outdoor temperature is at or above a set outdoor temperature +2°C.	TB6 K51-K52	
(q) DEFROST SIGNAL	Close/Open	The unit is in defrost mode.	The unit is not in defrost mode.	TB6 K53-K54	
(r) DRAIN PAN HEATER SIGNAL	Close/Open	Outdoor temperature has dropped below a set outdoor temperature.	Outdoor temperature is at or above a set outdoor temperature +2°C.	TB6 K63-K64	
RC/M- NET	REMOTE CONTROLLER	PAR-W21MAA			TB5 RA-RB
	M-NET	-			TB5 M1-M2

External signal interface

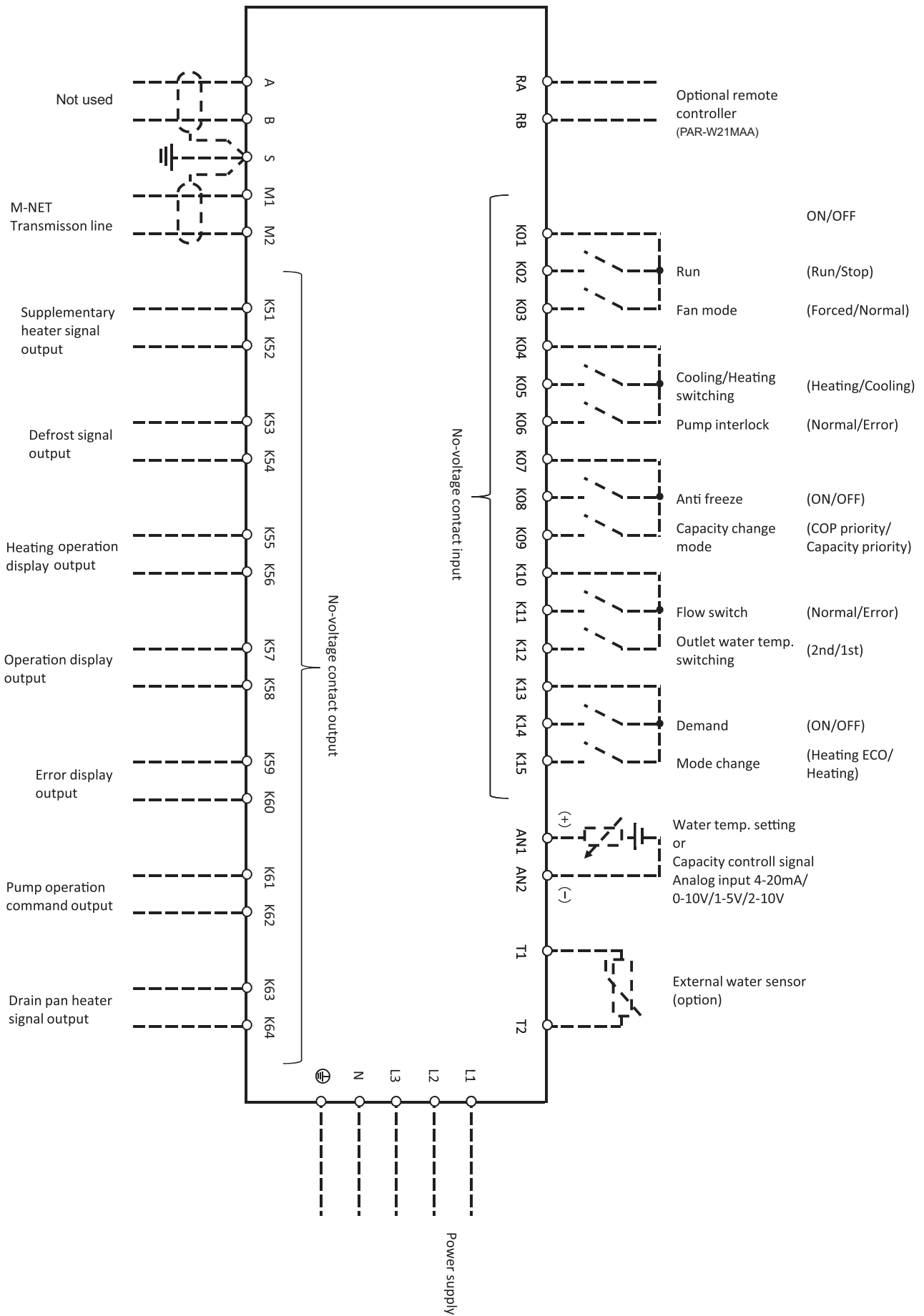

6. Troubleshooting

Troubleshooting must be performed only by personnel certified by Mitsubishi Electric.

[1] Diagnosing Problems for which No Error Codes Are Available

If a problem occurs, please check the following. If a protection device has tripped and brought the unit to stop, resolve the cause of the error before resuming operation.

Resuming operation without removing the causes of an error may damage the unit and its components.

Problem	Check item		Cause	Solution
The unit does not operate.	The fuse in the control box is not blown.	The power lamp on the circuit board is not lit.	The main power is not turned on.	Switch on the power.
		The power lamp on the circuit board is lit.	The pump interlock circuit is not connected.	Connect the pump interlock circuit wiring to the system.
			The flow switch wiring is not connected.	Connect the flow switch wiring to the system.
	The fuse in the control box is blown.	Measure the circuit resistance and the earth resistance.	Short-circuited circuit or ground fault	Resolve the cause, and replace the fuse.
	Automatic Start/Stop thermistor has tripped.	Water temperature is high. (Cooling)	The setting for the automatic Start/Stop thermistor is too high.	Change the setting for the automatic Start/Stop thermistor.
		Water temperature is low. (Heating)	The setting for the automatic Start/Stop thermistor is too low.	Change the setting for the automatic Start/Stop thermistor.
The unit is in operation, but the water does not heat up. (Heating)	Water temperature is low.	The water inlet/outlet temperature differential is normal.	The water-heating load is too high.	Install more units.
			Low refrigerant charge due to a leak.	Perform a leakage test, repair the leaks, evacuate the system, and charge the refrigerant circuit with refrigerant.
		The water inlet/outlet temperature differential is small.	LEV fault in the main circuit	Replace the LEV in the main circuit.
			Compressor failure	Replace the compressor.
	Water temperature is high.	-	High pressure is too high, or low pressure is too low.	Operate the units within the specified pressure range.
			Water flow shortage	Increase the water flow rate.
			Problem with the external devices	Repair the devices.
			Problem with the external devices	Repair the devices.
The unit is in operation, but the water does not heat up. (Cooling)	Water temperature is low.	-	Water flow shortage	Increase the water flow rate.
			Problem with the external devices	Repair the devices.
	Water temperature is high.	The water inlet/outlet temperature differential is normal.	The water-cooling load is too high.	Install more units.
			Low refrigerant charge due to a leak.	Perform a leakage test, repair the leaks, evacuate the system, and charge the refrigerant circuit with refrigerant.
		The water inlet/outlet temperature differential is small.	LEV fault in the main circuit	Replace the LEV in the main circuit.
			Compressor failure	Replace the compressor.
			High pressure is too high, or low pressure is too low.	Operate the units within the specified pressure range.
				Operate the units within the specified pressure range.

[2] Diagnosing Problems Using Error Codes

If a problem occurs, please check the following before calling for service.

(1) Check the error code against the table below.

(2) Check for possible causes of problems listed in the "Cause" column that correspond to the error code.

(3) If the error codes that appear on the display are not listed in the table below, or no problems were found with the items listed in the "Cause" column, please consult your dealer or servicer.

Diagnosing Problems Using Error Codes

Error code *1	Error type		Cause (Installation/Setting error)	Cause (Parts problems)	Error reset *2	
					Unit side (PCB)	Remote
					SWS1	Operation SW
4 106	Power supply fault *3		Power supply fault occurred when the operation switch is switched on.	-	○	○
2500	Water supply cutoff (Flow switch has been triggered.)		The water flow rate dropped below the flow switch threshold. Water supply cutoff	<ul style="list-style-type: none"> Open-circuited flow switch Broken flow switch wiring 	○	○
2501 2550	Water supply cutoff (detection by sensor)		No water Water supply cutoff	<ul style="list-style-type: none"> Inlet water thermistor fault Outlet water thermistor fault 	○	○
1302 1303	High pressure fault		No water Water supply cutoff	<ul style="list-style-type: none"> Linear expansion valve fault High-pressure sensor fault 	○	○
1176	Discharge SH fault		-	<ul style="list-style-type: none"> Low-pressure sensor fault ACC inlet refrigerant temperature thermistor fault High-pressure sensor fault Discharge refrigerant temperature thermistor fault Linear expansion valve fault 	○	○
1301	Low pressure fault		The outdoor temperature was below the operating range.	<ul style="list-style-type: none"> Low-pressure sensor fault ACC inlet refrigerant temperature thermistor fault Linear expansion valve fault Refrigerant deficiency (refrigerant gas leak) 	○	○
1189	ACC inlet SH fault		-	<ul style="list-style-type: none"> ACC inlet refrigerant temperature thermistor fault Linear expansion valve fault Low-pressure sensor fault 	○	○
5 110	Thermistor fault	Outdoor temperature (TH10)	-	Broken or shorted thermistor wiring	○	○
5 101		Inlet water temperature (TH1)	-	Broken or shorted thermistor wiring	○	○
5 102		Inlet water temperature (TH2)	-	Broken or shorted thermistor wiring	○	○
5 103		Outlet water temperature (TH3)	-	Broken or shorted thermistor wiring	○	○
5 105		ACC inlet refrigerant temperature (TH5/TH25)	-	Broken or shorted thermistor wiring	○	○
5 106		Air heat exchanger refrigerant temperature (TH6/TH26)	-	Broken or shorted thermistor wiring	○	○
5 107		Water heat exchanger refrigerant temperature (TH7/TH27)	-	Broken or shorted thermistor wiring	○	○
5 111		Discharge refrigerant temperature (TH11/TH21)	-	Broken or shorted thermistor wiring	○	○
5 115	External water temperature (TH15)	-	Broken or shorted thermistor wiring	○	○	
5201	High-pressure sensor fault/high-pressure fault		-	Broken or shorted pressure sensor wiring	○	○
5202	Low-pressure sensor fault/low-pressure fault		-	Broken or shorted pressure sensor wiring	○	○
7113	Model setting error 1		Dip switches on the PCB were set incorrectly during maintenance.	-	×	×
7117	Model setting error 2		-	CNTYP1 resistor fault (connected to the Main control board)	×	×
4 115	Power supply frequency fault		Power supply frequency is a frequency other than 50 Hz or 60 Hz.	-	×	×
4 102	Open phase		There is an open phase.	<ul style="list-style-type: none"> Circuit board fault 	×	×
1102	Discharge temperature fault (A discharge refrigerant temperature of 120°C or above is detected momentarily while the compressor is in operation.)		No water Abrupt change in water temperature (5K/min. or greater) Pump failure	<ul style="list-style-type: none"> High-pressure sensor fault Linear expansion valve fault Refrigerant deficiency (refrigerant gas leak) 	○	○
1138	Hot water abnormal rise		Drop in water flow or water supply cutoff Water temperature rise	-	○	○
1503	Cold water abnormal drop *4		Drop in water flow or water supply cutoff Water temperature drop	-	○	○

Error code *1	Error type		Cause (Installation/Setting error)	Cause (Parts problems)	Error reset *2	
					Unit side (PCB)	Remote
					SWS1	Operation SW
15 10	Gas leak fault		-	<ul style="list-style-type: none"> High pressure sensor fault Refrigerant deficiency (refrigerant gas leak) 	○	○
15 12	Low evaporation temperature fault		Drop in water flow Water temperature drop	-	○	○
4 1 16	Fan motor fault		Strong wind from the outside	<ul style="list-style-type: none"> Fan motor fault FANCONT board fault 	○	○
4 1 22	Fan interlock fault		Disconnection of wiring	<ul style="list-style-type: none"> Fan motor fault FANCONT board fault 	○	○
4250 (101)	Inverter error	IPM error	-	<ul style="list-style-type: none"> INV board fault Ground fault of the compressor Coil problem IPM error (loose terminal screws, cracked due to swelling) Items listed under "Heatsink overheat protection" below 	○	○
		ACCT overcurrent	-	<ul style="list-style-type: none"> INV board fault Ground fault of the compressor Coil problem IPM error (loose terminal screws, cracked due to swelling) 	○	○
		DCCT overcurrent	-	<ul style="list-style-type: none"> IPM error (loose terminal screws, cracked due to swelling) 	○	○
		Overcurrent relay trip (effective value) (During operation)	-		○	○
		Overcurrent relay trip (momentary value) (During operation)	-		○	○
		Short-circuited IPM/ground fault (During operation)	-	<ul style="list-style-type: none"> Ground fault of the compressor IPM error (loose terminal screws, cracked due to swelling) 	○	○
		Overcurrent error due to a short-circuited (During operation)	Inter-phase voltage drop (Inter-phase voltage at or below 180 V)	<ul style="list-style-type: none"> Ground fault of the compressor Shorted output wiring 	○	○
4220 (108)	Voltage related problems during operation	Bus voltage drop protection	Momentary power failure/power failure Power supply voltage drop (Inter-phase voltage is 180 V or below.) Voltage drop	<ul style="list-style-type: none"> INV board CNDC2 wiring fault INV board fault 52C fault Diode stack failure 	○	○
		Bus voltage rise protection	Incorrect power supply voltage	<ul style="list-style-type: none"> INV board fault 	○	○
		VDC error	Power supply voltage rise or drop	<ul style="list-style-type: none"> PCB fault 	○	○
		Logic error	Malfunction due to external noise interference <ul style="list-style-type: none"> Faulty grounding Improper transmission and external wiring installation (Shielded cable is not used.) Low-voltage signal wire and high-voltage wire are in contact. (Placing the signal wire and power wire in the same conduit) 	<ul style="list-style-type: none"> INV board fault 	○	○
4230	Heatsink fault (Heatsink overheat protection)	Power supply voltage drop (Inter-phase voltage is 180 V or below.) Clogged heatsink cooling air passage	<ul style="list-style-type: none"> Fan motor fault THHS sensor fault IPM error (loose terminal screws, cracked due to swelling) 	○	○	
		Overload protection	Clogged heatsink cooling air passage Power supply voltage drop (Inter-phase voltage is 180 V or below.)	<ul style="list-style-type: none"> THHS sensor fault Current sensor fault INV circuit fault Compressor fault 	○	○
530 1 (115)	ACCT sensor fault		-	<ul style="list-style-type: none"> INV board fault Ground fault of the compressor and IPM error 	○	○
530 1 (116)	DCCT sensor		-	<ul style="list-style-type: none"> Poor contact at the INV board connector CNCT Poor contact at the INV board connector DCCT Ground fault of the compressor and IPM error 	○	○
530 1 (117)	ACCT sensor/circuit fault		-	<ul style="list-style-type: none"> Poor contact at the INV board connector CNCT2 (ACCT) ACCT sensor fault 	○	○

Error code *1	Error type	Cause (Installation/Setting error)	Cause (Parts problems)	Error reset *2		
				Unit side (PCB)	Remote	
				SWS1	Operation SW	
5301 (118)	Inverter error	DCCT sensor/circuit fault	-	• Poor contact at the INV board connector CNCT • Poor contact at the INV board connector DCCT • DCCT sensor fault • INV board fault	○	○
5301 (119)		Open-circuited IPM/loose ACCT sensor	-	• Disconnected ACCT sensor (CNCT2) • ACCT sensor fault • Broken compressor wiring • INV circuit fault (IPM error etc.)	○	○
5301 (120)		Faulty wiring	-	• ACCT sensor is connected in the wrong phase. • ACCT sensor is connected in the wrong orientation.	○	○
5114		THHS sensor/circuit fault	-	• THHS sensor contact failure • THHS sensor fault • INV board fault	○	○
0403		Serial communication error	-	• Communication error between control board and INV board (noise interference, broken wiring)	○	○
-		IPM system error	INV board switch setting error	• Wiring or connector connection between connectors on IPM-driven power supply circuit • INV board fault	○	○
6831	Remote controller error (incl. remote controller wiring fault)	Remote controller signal reception error 1	Remote controller cable is not connected. Broken wiring	• Broken remote controller wiring • Main control board communication circuit fault	-	-
6832		Remote controller signal transmission error	Communication error due to external noise interference	• Main control board communication circuit fault	-	-
6834		Remote controller signal reception error 2	Communication error due to external noise interference	• Main control board communication circuit fault	-	-
6833		Remote controller over current	Remote controller cable short circuit Remote controller malfunction	• Broken remote controller wiring	×	×
4126	Analog input error (Control board (MAIN) CN421)	Analog input type fault (SW3-1, SW3-2)	• Broken or open analog signal output device wiring (CN421)	-	-	
6500	Communication error between the main and sub units Communication error between the MAIN and SUB circuits	-	-	-	-	
6500	Transmission line power supply PCB fault	Communication error due to external noise interference	• Broken wiring to the transmission power supply circuit board (between the main and sub units) • Transmission power supply PCB communication circuit fault	×	×	
6502	Communication error between the main and sub units (Simple multiple unit control mode)	Communication error due to external noise interference		-	-	
6503				-	-	
6506				-	-	
6507			-	-		

*1: If an error occurs, error codes shown above will appear in the 4-digit digital display on the PCB and the remote controller.

*2: Definition of symbols in the "Error reset" column.

○: Errors that can be reset if the remote reset setting on the unit is set to "Enable" (factory setting)
Errors that cannot be reset if the remote reset setting on the unit is set to "Disable"

×: Errors that cannot be reset

-: Errors that will be automatically cancelled once its cause is removed

*3: Power failure will be detected as an error only when the "Automatic recovery after power failure" setting on the unit is set to "Disable."
(The default setting for the "Automatic recovery after power failure" setting is "Enable.")

*4: Before resetting this error, remove its causes. Resuming operation without removing the causes of heat exchanger freeze up will cause heat exchanger damage.

[3] Calling for Service

If the problem cannot be solved by following the instructions provided in the table on the previous pages, please contact your dealer or servicer along with the types of information listed below.

(1) Model name

The model name is a string that starts with "EAHV" or "EACV" and is found on the lower part of the unit.

(2) Serial number

Example: 75W00001

(3) Error code

(4) Nature of the problem in detail

Example: The unit stops approximately one minute after it was started.

7. Operating the Unit

[1] Initial Operation

1. Make sure the Run/Stop switch that controls the unit on the local control panel is switched off.
2. Switch on the main power.
3. Leave the main power switched on for at least 12 hours before turning on the Run/Stop switch that controls the unit on the on-site control panel to warm up the compressor.
4. Switch on the Run/Stop switch that controls the unit on the on-site control panel.

[2] Daily Operation

To start an operation

Switch on the Run/Stop switch that controls the unit on the local control panel, or press the ON/OFF button on the remote controller. (*1)

Note

The unit described in this manual features a circuit that protects the compressor from short-cycling. Once the compressor stops, it will not start up again for up to 12 minutes. If the unit does not start when the ON/OFF switch is turned on, leave the switch turned on for 12 minutes. The unit will automatically start up within 12 minutes.

To stop an operation

Switch off the Run/Stop switch that controls the unit on the on-site control panel, or press the ON/OFF button on the remote controller. (*1)

*1 Refer to the following pages for how to use the remote controller.

IMPORTANT

- Keep the main power turned on throughout the operating season, in which the unit is stopped for three days or shorter (e.g., during the night and on weekends).
- Unless in areas where the outdoor temperature drops to freezing, switch off the main power when the unit will not be operated for four days or longer. (Switch off the water circulating pump if the pump is connected to a separate circuit.)
- When resuming operation after the main power has been turned off for a full day or longer, follow the steps under "Initial Operation".
- If the main power was turned off for six days or longer, make sure that the clock on the unit is correct.

[3] Using the Unit in Sub-freezing

In areas where temperature drops to freezing during the periods of non-use, blow the water out of the pipes or fill the pipes with anti-freeze solution.

Not doing so may cause the water to freeze, resulting in burst pipes and damage to the unit or the furnishings.

In areas where temperature can drop low enough to cause the water in the pipes to freeze, operate the unit often enough to prevent the water from freezing.

Frozen water in the water circuit may cause the water to freeze, resulting in burst pipes and damage to the unit or the furnishings.

In areas where temperature drops to freezing, use an anti-freeze circuit and leave the main power turned on to prevent the water in the water circuit from freezing and damaging the unit or causing water leakage and resultant damage to the furnishings.

- In areas where the air around the unit drops below freezing, leave the main switch turned on even when the unit will not be operated for four days or longer. Leave the switch on the water circulation pump turned on if the pump is connected to a separate circuit.
- If the unit is left turned off for a while (e.g., overnight) when the temperature around the unit drops below freezing, the water in the water circuit will freeze and damage the pipes and the heat exchanger.
- The recommended electric circuit has an anti-freeze circuit. For this circuit to function, the main power must be turned on.
- If the water circulation pump is connected differently from the recommended way, make sure the circuit has some type of anti-freeze function*.
(* A function that automatically operates the water circulation pump to prevent the water in the circuit from freezing when the water temperature drops.)

[4] Using the Remote Controller

<1> Starting and Stopping Operation and Changing the Operation Mode

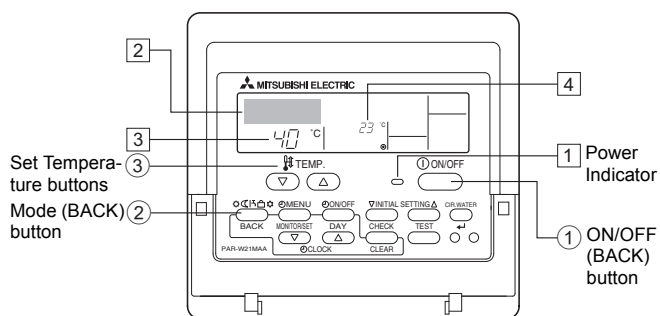

To Start Operation

1. Press the ON/OFF (BACK) button ①.
The power indicator ④ and the display will light up.

To Stop Operation

1. Press the ON/OFF (BACK) button ① while the unit is in operation.
The power indicator ④ and the display will light off.
The remote controller will remember the last mode and temperature settings when turned off.

To select the Mode

1. With the power turned on, press the Mode (BACK) button ② until the desired mode appears.
 - Each press changes the operation mode in the following sequence (see notes *1 and *2 below):
Heating→Heating ECO→Anti-freeze→Cooling→Back to Heating.
The currently selected mode will appear in the area labeled ④.

*1 If K07-K08 or K13-K15 is ON (CLOSE), the operation mode except Cooling mode cannot be changed from the remote controller.

*2 The available modes vary depending on the model.

*3 Refer to section [5] "Function Settings" [5]-2. (2) for how to change the settings for a specific function.

<2> Setting the Water Temperature

The current water temperature will appear in the area labeled [3].

How to Change the Temperature Setting

- To lower the water temperature setting
Press the Set Temperature button [3].
- To raise the water temperature setting
Press the Set Temperature button [3].
 - Each press increases or decreases the temperature by 1 °C (1 °F).
The current setting will appear in the area labeled [3] in the figure on the previous page.
 - The settable ranges for the "Hot Water" and "Heating" modes are as follows. *1, *2

Heating	Cooling
30 °C - 55 °C	5 °C - 25 °C
86 °F - 131 °F *3	41 °F - 77 °F *3

Note:

- *1 Available ranges vary depending on the type of unit connected.
- *2 If the temperature ranges are restricted from the remote controller, the settable ranges may be narrower than shown above. If an attempt is made to set a value outside of the restricted range, the display will show a message indicating that the range is currently restricted.
For information about how to set and clear the restrictions, refer to section [5], item [5]-2. (3).
- *3 Temperatures can be displayed in Celsius or Fahrenheit (factory setting: Fahrenheit). For information about how to select °C or °F, refer to section [5], item [5]-4. (1).
 - Water temperature can be controlled based on the outlet temperature.
 - The water temperature range that can be displayed is between 0 °C to 100 °C. Outside this range, the display flashes either 0 °C or 100 °C.

<3> Setting the Day of the Week and Time

Use this screen to set and change the current day of the week and time settings.

Note:

The day and time will not appear if the clock display is disabled from the remote controller on the Function Selection menu.

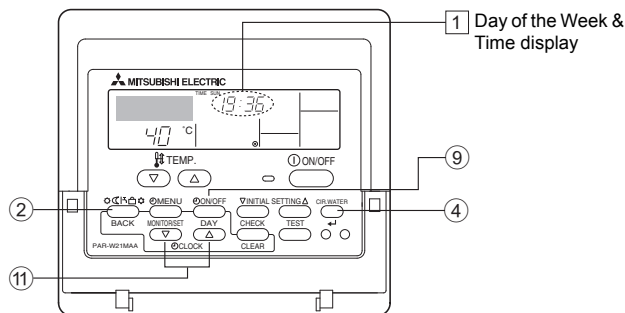

How to Set the Day of the Week and Time

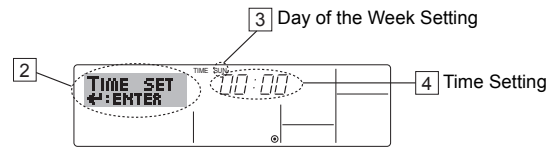

- Press the or Set Time button [11] to bring up **TIME SET** in the area labeled [2].
- Press the **TIMER ON/OFF (SET DAY)** button [9] to set the day (labeled [3] in the figure).
 - * Each press advances the day.
- Press the Set Time button [11] as necessary to set the time.
 - * When the button is held down, the time (at [4]) will increment first in one-minute intervals, then in ten-minute intervals, and then in one-hour intervals.
- After making the appropriate settings in Steps 2 and 3, press the **CIR.WATER** button [4] to save the values.

Note:

The changes will be lost unless the Mode (BACK) button [2] is pressed before the **CIR.WATER** button [4] is pressed.

- Press the Mode (BACK) button [2] to complete the setting procedure and return the display to the normal operation screen. The new day and time will appear in the area labeled [3].

<4> Using the Timer

Three types of timers are available as follows: [1] Weekly timer, [2] Simple timer, or [3] Auto-Off timer. The timer type can be selected from the remote controller on the Function Selection menu.

For information about how to use the Function Selection menu on the remote controller, refer to section [5], item [5]-3. (3).

Using the Weekly Timer

- The weekly timer can be used to schedule up to six events for each day of the week.
 - Each operation event can consist of any of the following: ON/OFF time together with a temperature setting, ON/OFF time only, or temperature setting only.
 - When the timer reaches the preset time, the schedule event will take place.
- The time can be set to the nearest minute.

Note:

- *1 The Weekly, Simple, and Auto-Off timers cannot be used concurrently.
- *2 The weekly timer will not operate when any of the following conditions is met.
The timer is off; the system is in error; a test run is in progress; the remote controller is performing self-check or remote controller check; the timer, function, day, or time is being set. If the ON/OFF status and/or the temperature setting is centrally controlled, their settings cannot be changed according to a schedule that was set from the remote controller.

Operation No.

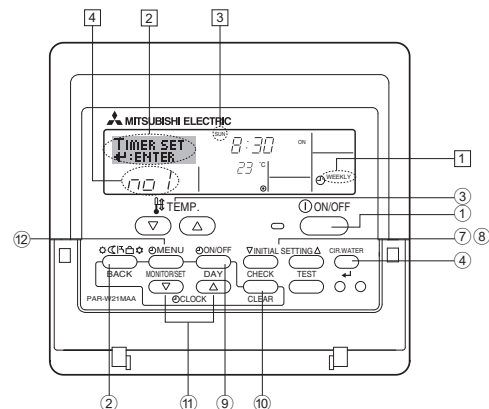

How to Set the Weekly Timer

- On the Normal Operation screen, make sure that the weekly timer icon **(1)** is displayed.
- Press the TIMER MENU button **(2)**, so that the "Set Up" appears on the screen **(2)**. (Each press toggles between "Set Up" and "Monitor".)
- Press the TIMER ON/OFF (SET DAY) button **(9)** to set the day. Each press advances the day, which appears in the area labeled **(3)**.
- Press the **(▽)** or **(△)** INITIAL SETTING button **(7)** or **(8)** to select a desired operation pattern number (1 through 6) **(4)**.
 - * (The remote-controller display on the previous page shows how the display would appear if operation No. 1 for Sunday were set to the values shown below.)

Setup Matrix

Op No.	Sunday	Monday	...	Saturday
No. 1	<ul style="list-style-type: none"> 8:30 ON 23 °C (73 °F) 			
No. 2	<ul style="list-style-type: none"> 10:00 OFF 	<ul style="list-style-type: none"> 10:00 OFF 	<ul style="list-style-type: none"> 10:00 OFF 	<ul style="list-style-type: none"> 10:00 OFF
...				
No. 6				

<Operation 1 settings for Sunday>
Start the unit at 8:30, with the temperature set to 23 °C (73 °F).

<Operation 2 settings for every day>
Turn off the unit at 10:00.

Note:

By selecting the day to "Sun Mon Tues Wed Thurs Fri Sat", the same action can be carried out at the same time every day.
(Example: In Operation No. 2 above, the unit is scheduled to be turned off at 10:00 every day.)

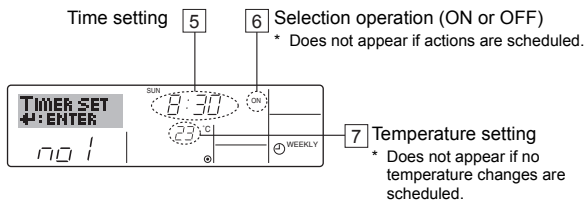

- Press the Set Time button **(11)** to set the time **(5)**.
 - * Time will first increment in one-minute intervals, then in ten-minute intervals, and then in one-hour intervals.
- Press the ON/OFF button **(1)** to select the desired operation (ON or OFF), at **(6)**.
 - * Each press toggles through the following options:
No display (no setting) → "ON" → "OFF"
- Press the Set Temperature button **(3)** to set the temperature **(7)**.
 - * Each press:
No display (no setting) ↔ 5 (41) ↔ 6 (43) ↔ ... ↔ 89 (192) ↔ 90 (194) ↔ No display. (Available temperature range: The temperature display range is between 5 °C (41 °F) and 90 °C (194 °F). The actual range which the temperature can be controlled will vary according to the type of the connected unit.)
- To clear the current values for the selected operation, press and quickly release the CHECK (CLEAR) button **(10)** once.
 - * The displayed time setting will change to "—:—", and the ON/OFF and temperature settings will disappear.
(To clear all weekly timer settings at once, hold down the CHECK (CLEAR) button **(10)** for two seconds or more. The display will begin flashing, indicating that all settings have been cleared.)
- After making the appropriate settings in Steps 5, 6, and 7, press the CIR.WATER **(4)** button **(4)** to save the values.

Note:

The changes will not be saved unless the Mode (BACK) button **(2)** is pressed before the CIR.WATER **(4)** button **(4)** is pressed.

If two or more different operation patterns have been scheduled for exactly the same time, only the operation with the highest Operation No. will be carried out.

- Repeat Steps 3 through 9 as necessary to add more settings.
- Press the Mode (BACK) button **(2)** to return to complete the setting procedure and return to the Normal Operation screen.
- To activate the timer, press the TIMER ON/OFF button **(9)**, so that the "Timer Off" icon **(10)** disappears.
 - * If no timer settings have been made, the "Timer Off" icon will flash on the screen.

How to View the Weekly Timer Settings

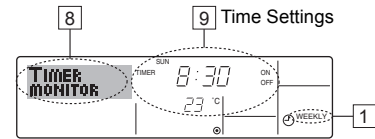

- Make sure that "WEEKLY" is displayed **(1)**.
- Press the TIMER MENU button **(2)** so that "Monitor" appears on the screen **(8)**.
- Press the TIMER ON/OFF (SET DAY) button **(9)** to select the desired day.
- Press the **(▽)** or **(△)** INITIAL SETTING button **(7)** or **(8)** to toggle through the settings **(9)**.
 - * Each press will advance the display to the next timer operation in order of time.
- To close the monitor display and return to the Normal Operation screen, press the Mode (BACK) button **(2)**.

To Turn Off the Weekly Timer

Press the TIMER ON/OFF button **(9)** so that "Timer Off" appears at **(10)**.

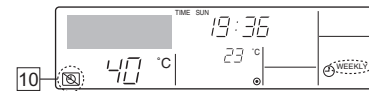

To Turn On the Weekly Timer

Press the TIMER ON/OFF button **(9)** so that the "Timer Off" icon **(10)** disappears.

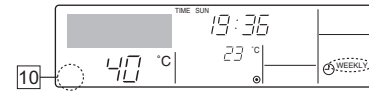

Using the Simple Timer

- The simple timer can be set in any of the following three ways.
 - Start time only: The unit starts when the set time has elapsed.
 - Stop time only: The unit stops when the set time has elapsed.
 - Start & stop times: The unit starts and stops at the respective elapsed times.
- The simple timer can be set to start and stop the unit only once each within a 72-hour period.
The time setting can be made in one-hour increments.

Note:

- *1 Weekly, Simple, and AUTO-off timers cannot be used concurrently.
- *2 The simple timer will not operate when any of the following conditions is met. The timer is disabled; the system is in error; a test run is in progress; the remote controller is performing self-check or remote controller check; or a function or the timer is being set. If the ON/OFF status and/or the temperature setting is centrally controlled, their settings cannot be changed according to the schedule that was set from the remote controller.

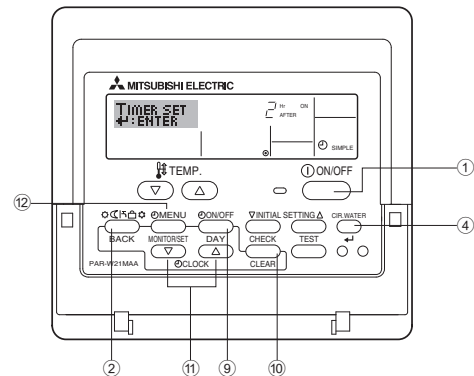

How to Set the Simple Timer

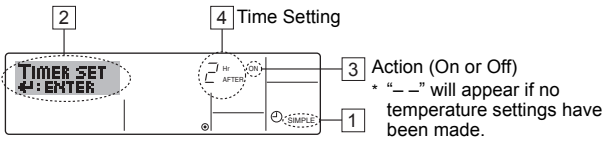

- On the normal operation screen, make sure that the simple timer icon is displayed (1). If anything other than "SIMPLE" is displayed, select the SIMPLE TIMER by referring to section [5], item [5]-3. (3).
- Press the TIMER MENU button (2), so that "Set Up" appears (2). (Each press toggles between "Set Up" and "Monitor".)
- Press the ON/OFF button (1) to display the current ON or OFF setting. Each press toggles between the time remaining until the unit turns on or off. ("ON" or "OFF" will appear in the area labeled 3.)
 - ON timer The unit will start operation when the specified hours have elapsed.
 - OFF timer The unit will stop operation when the specified hours have elapsed.
- With "ON" or "OFF" displayed on the screen (3), press the Set Time button (1) to set the hours until the unit turns on or off (4).
 - Available Range: 1 to 72 hours
- To set both the ON and OFF times, repeat Steps 3 and 4.
 - * Note that ON and OFF times cannot be set to the same value.
- To clear the current ON or OFF setting: Display the ON or OFF setting (see step 3) and then press the CHECK (CLEAR) button (10) so that "-" appears where the remaining time was. To use only the ON-timer or the OFF-timer, make sure that the time setting for the timer that will not be used is set to "-".
- After completing steps 3 through 6 above, press the CIR.WATER button (4) to save the value.

Note:

The changes will not be saved unless the Mode (BACK) button (2) is pressed before the CIR.WATER button (4) is pressed.

- Press the Mode (BACK) button (2) to return to the Normal Operation screen.
- Press the TIMER ON/OFF button (9) to start the timer countdown. When the timer is running, the remaining time should appear on the screen. **Make sure that the remaining time is displayed on the screen and that it is correct.**

Viewing the Current Simple Timer Settings

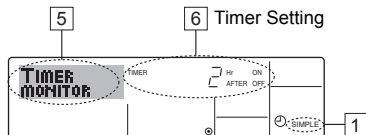

- Make sure that "SIMPLE" is displayed (1).
- Press the TIMER MENU button (2), so that "Monitor" appears on the screen (5).
 - If the ON or OFF simple timer is running, the current timer value will appear in the area labeled 6.
 - If ON and OFF values have both been set, the two values will appear alternately.
- Press the Mode (BACK) button (2) to close the monitor display and return to the Normal Operation screen.

To Turn Off the Simple Timer

Press the TIMER ON/OFF button (9) so that the timer setting no longer appears on the screen (at 7).

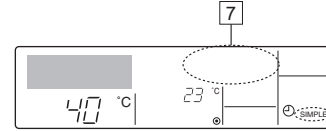

To Turn On the Simple Timer

Press the TIMER ON/OFF button (9) so that the timer setting appears in the area labeled 7.

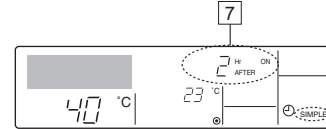

Examples

The two examples below show how the screen will appear when both the ON- and Off- timers have been set.

Example 1:

The ON-timer is set to 3 hours, and the OFF-timer is set to 7 hours.

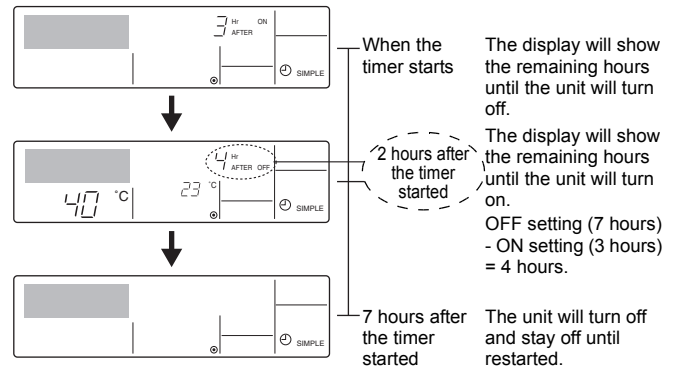

Example 2:

The ON-timer is set to 5 hours, and the OFF-timer is set to 2 hours.

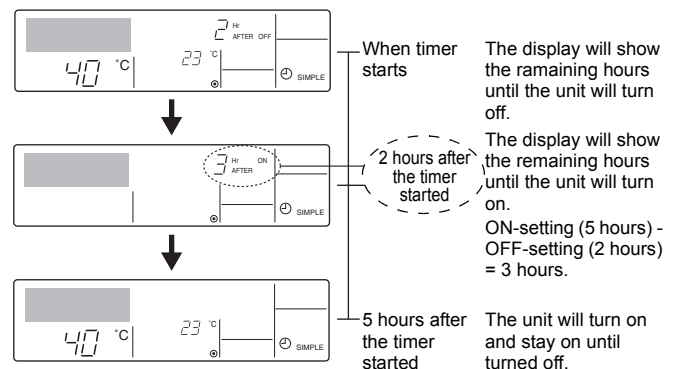

Using the Auto-Off Timer

1. This timer begins countdown when the unit starts, and shuts the unit off when the set time has elapsed.
2. Available settings range from 30 minutes to 4 hours in 30-minute intervals.

Note:

- *1 Weekly Timer/Simple Timer/Auto Off Timer cannot be used at the same time.
- *2 The Auto Off timer will not operate when any of the following conditions is in effect.
The timer is off; the system is in error; a test run is in progress; the remote controller is performing self-check or remote controller check; or a function or the timer is being set. If the ON/OFF status and/or the temperature setting is centrally controlled, their settings cannot be changed according to the schedule that was set from the remote controller.

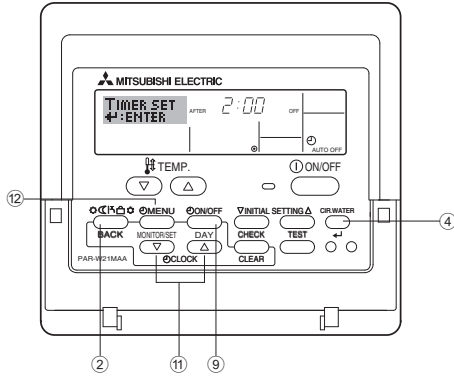

How to Set the Auto-Off TIMER

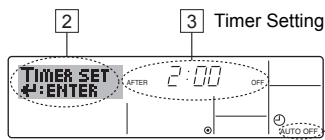

1. On the Normal Operation screen, make sure that "AUTO OFF" is displayed (1). If anything other than "AUTO OFF" is displayed, select the AUTO-OFF TIMER by referring to section [5], item [5]-3. (3).
2. Press and hold the TIMER MENU button (2) for 3 seconds, so that "Set Up" appears on the screen (2). (Each press toggles between "Set Up" and "Monitor".)
3. Press the Set Time button (11) to set the OFF time (3).
4. Press the CIR.WATER button (4) to save the setting.

Note:

The changes will not be saved unless the Mode (BACK) button (2) is pressed before the CIR.WATER button (4) is pressed.

5. Press the Mode (BACK) button (2) to complete the setting procedure and return to the Normal Operation screen.
6. If the unit is already running, the timer will start counting down immediately. **Make sure that the remaining time is displayed on the screen and that it is correct.**

Checking the Current Auto-Off Timer Setting

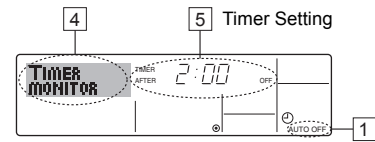

1. Make sure that "AUTO OFF" is displayed (1).
2. Press and hold the TIMER MENU button (2) for 3 seconds so that "Monitor" appears (4).
 - The time remaining until the unit will turn off will appear in the area labeled (5).
3. To close the monitor display and return to the Normal Operation screen, press the Mode (BACK) button (2).

To Turn Off the Auto-Off Timer

- Press and hold the TIMER ON/OFF button (9) for 3 seconds so that "Timer Off" appears (6) and the timer value (7) disappears.

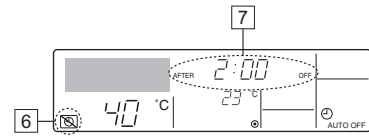

- Alternatively, turn off the unit itself. The timer value (7) will disappear from the screen.

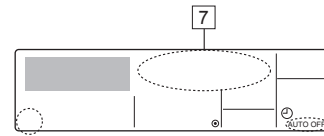

To Turn On the Auto-Off Timer

- Press and hold the TIMER ON/OFF button (9) for 3 seconds. The "Timer Off" will disappear (6), and the timer setting will appear on the display (7).
- Alternatively, turn on the unit. The timer value will appear in the area labeled (7).

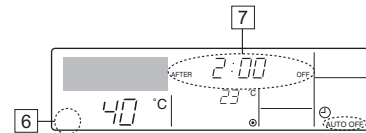

[5] Function Settings

The settings for the following remote controller functions can be changed using the remote controller function selection mode. Change the settings as necessary.

Item 1	Item 2	Item 3 (Setting content)
1. Display language setting ("CHANGE LANGUAGE")	Display language selection	<ul style="list-style-type: none"> Use to select the display language from available languages.
2. Function lock settings ("FUNCTION SELECTION")	(1) Function lock ("LOCKING FUNCTION")	<ul style="list-style-type: none"> Use to lock functions.
	(2) Operation mode skip setting ("SELECT MODE")	<ul style="list-style-type: none"> Use to show or hide specific modes.
	(3) Temperature range limit setting ("LIMIT TEMP FUNCTION")	<ul style="list-style-type: none"> Use to restrict the temperature range.
3. Basic function settings ("MODE SELECTION")	(1) Remote controller main/sub setting ("CONTROLLER MAIN/SUB")	<ul style="list-style-type: none"> Use to designate the remote controller as Main or Sub. *When two remote controllers are connected to one group, one controller must be set to sub.
	(2) Use of clock setting ("CLOCK")	<ul style="list-style-type: none"> Use to enable or disable the clock.
	(3) Timer function setting ("WEEKLY TIMER")	<ul style="list-style-type: none"> Use to select a timer type.
	(4) Contact number setting ("CALL.")	<ul style="list-style-type: none"> Use to show or hide, or enter the emergency contact number.
	(5) Temp offset setting ("TEMP OFF SET FUNCTION")	<ul style="list-style-type: none"> Use to show or hide the offset value.
4. Display options ("DISP MODE SETTING")	(1) Temperature unit °C/°F setting ("TEMP MODE °C/°F")	<ul style="list-style-type: none"> Use to show or hide the temperature unit (°C or °F).
	(2) Water temperature display setting ("WATER TEMP DISP SELECT")	<ul style="list-style-type: none"> Use to show or hide the water temperature.

Function setting flowchart

[1] Stop the unit and go into the remote controller function selection mode. → [2] Select from item 1. → [3] Select from item 2. → [4] Make the setting. → [5] Return to the Normal Operation screen.

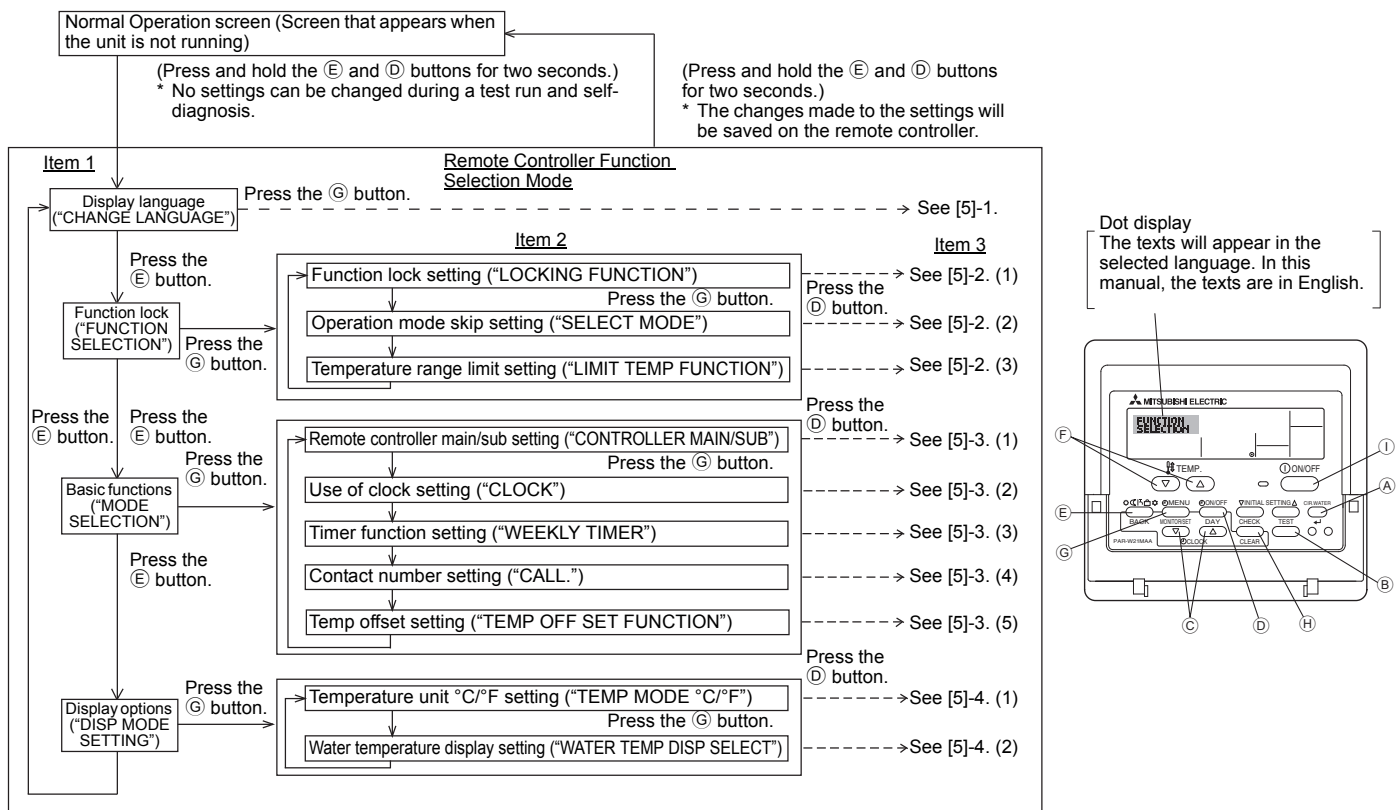

Settings details

[5]-1. Display language setting

The display language can be selected from the languages listed below.

- Press the [MENU] button to change the language.
 - ① English (GB), ② German (D), ③ Spanish (E), ④ Russian (RU), ⑤ Italian (I), ⑥ French (F), ⑦ Swedish (SW)

[5]-2. Function lock settings

(1) Function lock

- Press the [ON/OFF] button to toggle through the following options.
 - ① no1: All buttons except the [ON/OFF] button will be locked.
 - ② no2: All buttons will be locked.
 - ③ OFF (Default): No buttons will be locked.
- * Press and hold the [CIR.WATER] and [ON/OFF] buttons simultaneously for two seconds on the Normal Operation screen to enable the button-lock function.

(2) Operation mode skip setting

The following modes can be made available for selection or can be hidden.

- Press the [ON/OFF] button to toggle through the following options.
 - ① Heating mode
 - ② Heating ECO mode
 - ③ Hot Water mode
 - ④ Anti-freeze mode
 - ⑤ Cooling mode
 - ⑥ OFF (Default): All modes will be available for selection.
- * The mode that is not supported on the connected unit will not be available, even if the mode is available for selection on the display.

(3) Temperature range limit setting

The temperature range for the following modes can be restricted. Once the range has been restricted, the preset temperature can only be set to a value within the restricted range.

- Press the [ON/OFF] button to toggle through the following options.
 - ① LIMIT TEMP HEATING MODE
 - ② LIMIT TEMP HOT WATER MODE
 - ③ LIMIT TEMP ANTI-FREEZE MODE
 - ④ LIMIT TEMP COOLING MODE
 - ⑤ OFF (Default) : The temperature ranges are not active.
- To increase or decrease the temperature, press the [TEMP. or] button.
- Settable range

Heating mode	: Lower limit: 30 ~ 55 °C (86 ~ 131 °F)
	Upper limit: 55 ~ 30 °C (131 ~ 86 °F)
Cooling mode	: Lower limit: 5 ~ 25 °C (41 ~ 77 °F)
	Upper limit: 25 ~ 5 °C (77 ~ 41 °F)
- * The settable range varies depending on the type of unit to be connected.

[5]-3. Basic functions

(1) Remote controller main/sub setting

- Press the [ON/OFF] button to toggle between the following options.
 - ① Main The controller will be designated as the main controller.
 - ② Sub The controller will be designated as the sub controller.

(2) Use of clock setting

- Press the [ON/OFF] button to toggle between the following options.
 - ① ON The clock function.
 - ② OFF The clock function.

(3) Timer function setting

- Press the [ON/OFF] button to toggle through the following options.
 - ① WEEKLY TIMER (Default)
 - ② AUTO OFF TIMER
 - ③ SIMPLE TIMER
 - ④ TIMER MODE OFF
- * When the use of clock setting is set to OFF, the "WEEKLY TIMER" cannot be used.

(4) Contact number setting

- Press the [ON/OFF] button to toggle through the following options.
 - ① CALL OFF The contact number will not be displayed when a problem occurs.
 - ② CALL **** * * * * * The contact number will be displayed when a problem occurs.
CALL_ Use this option to enter the contact number.
- Setting the contact number
To set the contact number, follow the following procedures.
Press the [TEMP. or] button to move the cursor to the right (left). Press the [CLOCK or] button to set the contact number.

(5) Temp offset setting

- Press the [ON/OFF] button to toggle between the following options.
 - ① ON The offset value will be displayed under the water temperature initial setting mode.
 - ② OFF The offset value will not be displayed.

[5]-4. Display options

(1) Temperature unit °C/°F setting

- Press the [ON/OFF] button to toggle between the following options.
 - ① °C Celsius
 - ② °F Fahrenheit

(2) Water temperature display setting

- Press the [ON/OFF] button to toggle between the following options.
 - ① ON The water temperature will be displayed.
 - ② OFF The water temperature will not be displayed.

8. Main Specifications

[1] Model name

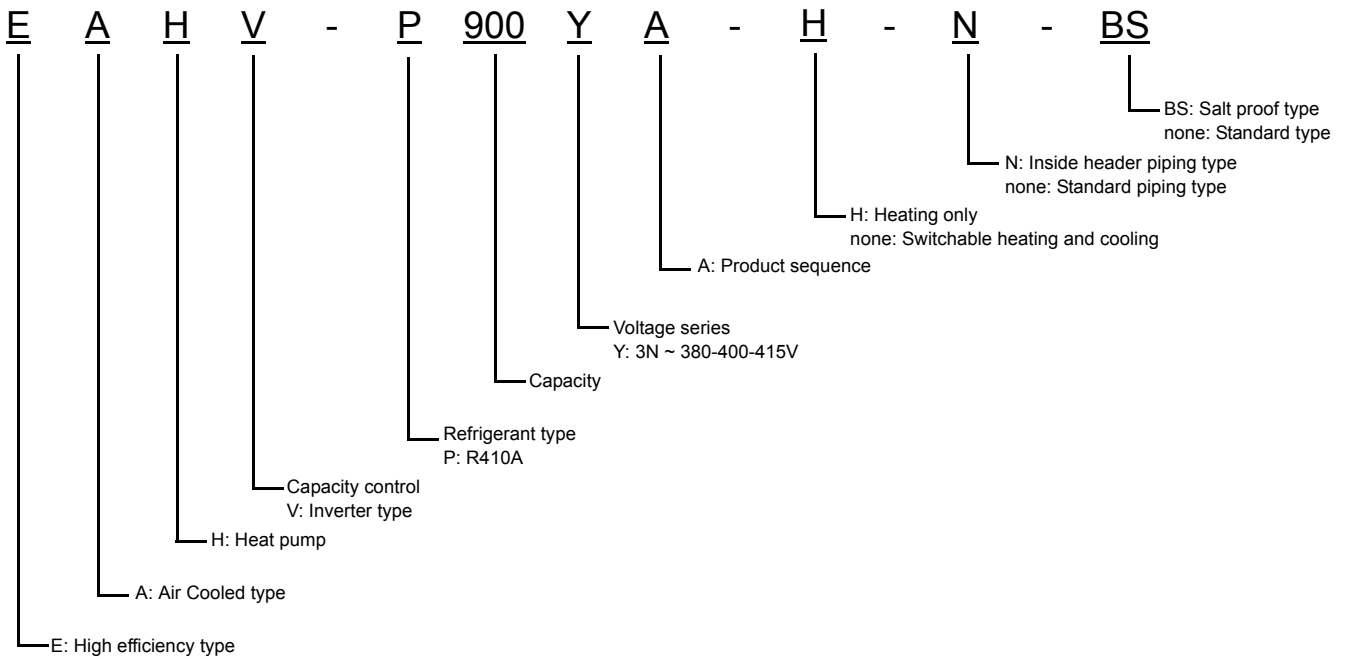
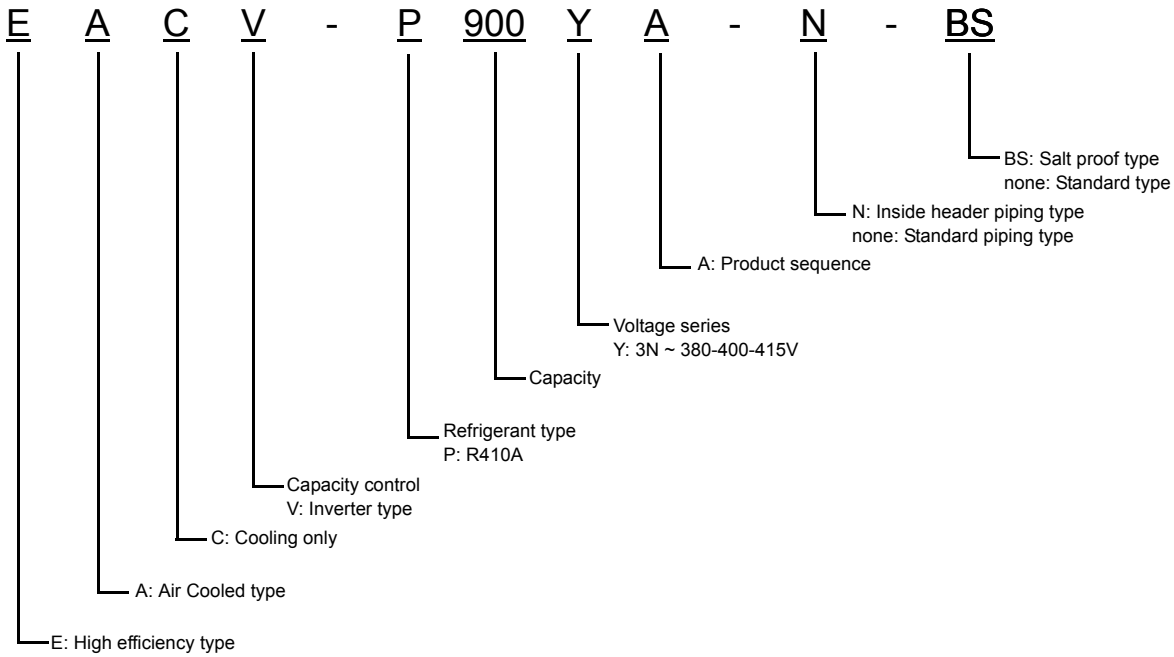

[2] Specifications

Model		EAHV-P900YA(-H)(-N)(-BS)/EACV-P900YA(-N)(-BS)	
Power source		3-phase 4-wire 380-400-415V 50/60Hz	
Cooling capacity*1 <Except EAHV-P900YA(-H)(-N)(-BS)>		kW	90.00
		kcal/h	77,400
		BTU/h	307,080
	Power input *3	kW	27.27
	Current input 380-400-415V	A	46.0 - 43.7 - 42.2
	EER (Pump input is not included)		3.30
	ESEER (Pump input is not included)		5.66
	EER (Includes pump input based on EN14511) *4		3.08
	ESEER (Includes pump input based on EN14511) *5		5.46
Water flow rate	m³/h	15.5	
Heating capacity*2 <Except EACV-P900YA(-N)(-BS)>		kW	90.00
		kcal/h	77,400
		BTU/h	307,080
	Power input *3	kW	25.71
	Current input 380-400-415V	A	43.4 - 41.2 - 39.7
	COP		3.50
	COP (Includes pump input based on EN14511) *4		3.25
	Water flow rate	m³/h	15.5
Maximum current input		A	61
Water pressure drop*6		kPa	135
Temp range	Cooling	°C	Outlet water 5~25 *8
		°F	Outlet water 41~77 *8
	Heating	°C	Outlet water 30~55 *8
		°F	Outlet water 86~131 *8
	Outdoor	°C	-15~43 *8
		°F	5~109.4 *8
Circulating water volume range		m³/h	7.7~25.8
Sound pressure level (measured in anechoic room) at 1m *6		dB (A)	65
Sound power level (measured in anechoic room) *6		dB (A)	77
Diameter of water pipe (Standard piping)	Inlet	mm (in)	50A (2B) housing type joint
	Outlet	mm (in)	50A (2B) housing type joint
Diameter of water pipe (Inside header piping)	Inlet	mm (in)	100A (4B) housing type joint
	Outlet	mm (in)	100A (4B) housing type joint
External finish		Polyester powder coating steel plate	
External dimensions H x W x D		mm	2450 x 2250 x 900
Net weight	Standard piping	kg (lbs)	EAHV: 987 (2176)/EACV: 957 (2110)
	Inside header piping	kg (lbs)	EAHV: 1022 (2253)/EACV: 992 (2187)
Design pressure	R410A	MPa	4.15
	Water	MPa	1.0
Heat exchanger	Water side	Stainless steel plate and copper brazing	
	Air side	Plate fin and copper tube	
Compressor	Type	Inverter scroll hermetic compressor	
	Maker	MITSUBISHI ELECTRIC CORPORATION	
	Starting method	Inverter	
	Quantity	2	
	Motor output	kW	11.7 x 2
	Case heater	kW	0.045 x 2
	Lubricant	MEL32	
Fan	Air flow rate	m³/min	77 x 6
		L/s	1283 x 6
		cfm	2719 x 6
	Type, Quantity	Propeller fan x 6	
	Starting method	Inverter	
	Motor output	kW	0.19 x 6
Protection	High pressure protection	High pres.Sensor & High pres.Switch at 4.15MPa (601psi)	
	Inverter circuit	Over-heat protection, Over current protection	
	Compressor	Over-heat protection	
Refrigerant	Type x charge	R410A x 19(kg) x 2 *7	
	Contorol	LEV	

*1 Under normal cooling conditions at outdoor temp 35°CDB/24°CWB (95°FDB/75.2°FWB)
outlet water temp 7°C (44.6°F)
inlet water temp 12°C (53.6°F)

- *2 Under normal heating conditions at outdoor temp 7°CDB/6°CWB (44.6°FDB/42.8°FWB)
outlet water temp 45°C (113°F)
inlet water temp 40°C (104°F)
- *3 Pump input is not included.
- *4 Pump is not included in e-series.
- *5 Calculated based on EUROVENT condition.
- *6 Under normal cooling or heating conditions
capacity 90kW
water flow rate 15.5m³/h
- *7 Amount of factory-charged refrigerant is 6 (kg) × 2.
Please add the refrigerant at the field.

- Please do not use the steel material for the water piping.
- Please always make water circulate, or pull the circulation water out completely when not in use.
- Please do not use groundwater or well water in direct.
- The water circuit must be closed circuit.
- Due to continuous improvement, the above specifications may be subject to change without notice.

*8

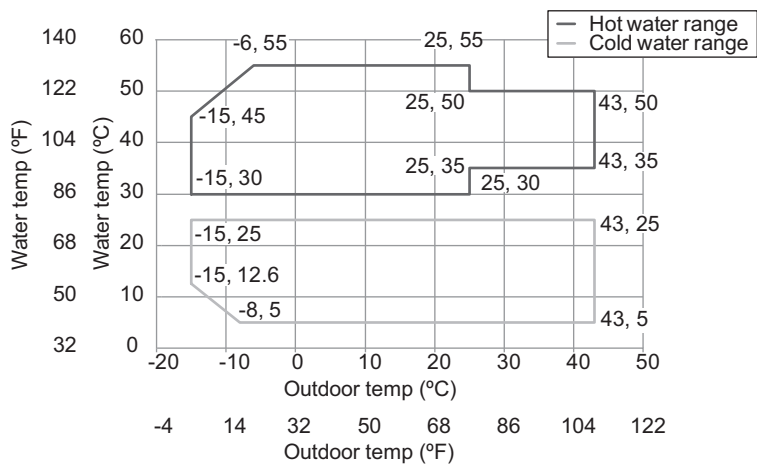

Unit converter

kcal/h = kW x 860

BTU/h = kW x 3,412

lbs = kg/0.4536

cfm = m³/min x 35.31

Spec label



AIR-COOLED CHILLING UNIT

MODEL **EAHV-P900YA <G>**

REFRIGERANT	R410A 19.0kg×2
LEGAL REFRIGERATION TON	10.60RT (5.30RT×2)
ALLOWABLE PRESSURE(Ps)	HP 4.15MPa (41.5bar) LP 2.21MPa (22.1bar)
WEIGHT	987kg
IP CODE	IP24
YEAR OF MANUFACTURE	

SERIAL No.

OPERATION	COOLING			HEATING		
	380	400	415	380	400	415
RATED VOLTAGE 3N~ V	380	400	415	380	400	415
FREQUENCY Hz	50/60			50/60		
CAPACITY	90.0			90.0		
	kcal/h			77400		
	Btu/h			307080		
RATED INPUT kW	29.2			27.6		
EER/COP	3.08			3.25		
RATED CURRENT A	46.0	43.7	42.2	43.4	41.2	39.7
MAX CURRENT A	61			61		
RATED CONDITION						
OUTLET WATER TEMP. °C	7			45		
INLET WATER TEMP. °C	12			40		
OUTDOOR DB/WB. °C	35/24			7/6		

EER/COP and capacity according to EN14511

Contains fluorinated greenhouse gases covered by the Kyoto Protocol.

MANUFACTURER:
MITSUBISHI ELECTRIC CORPORATION
AIR-CONDITIONING & REFRIGERATION SYSTEMS WORKS
5-66, TEBIRA, 6-CHOME, WAKAYAMA CITY, JAPAN
MADE IN JAPAN

DWG.No.KC79R665H05

[3] Technical documentation of fan

TECHNICAL DOCUMENTATION

TECHNICAL DOCUMENTATION & PRODUCT INFORMATION

PRODUCT MODEL	EAHV-P900YA(-H)(-N)(-BS)/EACV-P900YA(-N)(-BS)
---------------	---

Requirements		Information
(1)	Overall efficiency (%)	34.2
(2)	Measurement category	A
(3)	Efficiency category	STATIC
(4)	Efficiency grade (N)	40
(5)	VSD	The VSD is integrated within the fan
(6)	Year of manufacture	2015
(7)	Manufacturer	<p> MITSUBISHI ELECTRIC CORPORATION HEAD OFFICE: TOKYO BUILDING 2-7-3, MARUNOUCHI, CHIYODA-KU, TOKYO 100-8310, JAPAN AUTHORIZED REPRESENTATIVE IN EU: MITSUBISHI ELECTRIC EUROPE B.V. HARMAN HOUSE, 1GEORGE STREET, UXBRIDGE, MIDDLESEX UB8 1QQ, U.K. COMMERCIAL REGISTRATION NO.33279602 </p>
(8)	Model number	EAHV-P900YA(-H)(-N)(-BS)/EACV-P900YA(-N)(-BS)
(9)	Motor power input (kW)	0.19
	Flow rate (m ³ /s)	1.28
	Pressure (Pa)	50.6
(10)	Rotations per minute	820
(11)	Specific ratio	1.0
(12)	Information relevant for facilitating disassembly, recycling or disposal at end-of-life	<p> Your product should be disposed of separately from household waste in line with local laws and regulations. When this product reaches its end of life, dispose of it at your local waste collection point/recycling centre. The separate collection and recycling of your product at the time of disposal will help conserve natural resources and ensure that it is recycled in a manner that protects human health and the environment. For more information for WEEE recyclers please contact us at http://www.mitsubishielectric.eu/contact_us_form </p>
(13)	Information relevant to minimise impact on the environment and ensure optimal life expectancy as regards installation, use and maintenance of the fan	<p> In addition to daily checks (eg cleaning of filters), periodic maintenance and checks by a skilled technician are required to ensure that the unit is maintained in a good condition for a long period of time, and that it may be used with confidence. </p>
(14)	Description of additional items used when determining the fan energy efficiency	-





This product is designed and intended for use in the residential,
commercial and light-industrial environment.

The product at hand is
based on the following
EU regulations:

- Low Voltage Directive 2006/95/EC
- Electromagnetic Compatibility Directive
2004/108/EC
- Pressure Equipment Directive 97/23/EC
- Machinery Directive 2006/42/EC

Please be sure to put the contact address/telephone number on
this manual before handing it to the customer.

MITSUBISHI ELECTRIC CORPORATION

HEAD OFFICE: TOKYO BLDG., 2-7-3, MARUNOUCHI, CHIYODA-KU, TOKYO 100-8310, JAPAN

Authorized representative in EU: MITSUBISHI ELECTRIC EUROPE B.V.

HARMAN HOUSE, 1 GEORGE STREET, UXBRIDGE, MIDDLESEX UB8 1QQ, U.K.