

**2012**

**R410A**

# TECHNICAL & SERVICE MANUAL

Models

**PEFY-P20VMA(L)-E, PEFY-P71VMA(L)-E  
PEFY-P25VMA(L)-E, PEFY-P80VMA(L)-E  
PEFY-P32VMA(L)-E, PEFY-P100VMA(L)-E  
PEFY-P40VMA(L)-E, PEFY-P125VMA(L)-E  
PEFY-P50VMA(L)-E, PEFY-P140VMA(L)-E  
PEFY-P63VMA(L)-E**

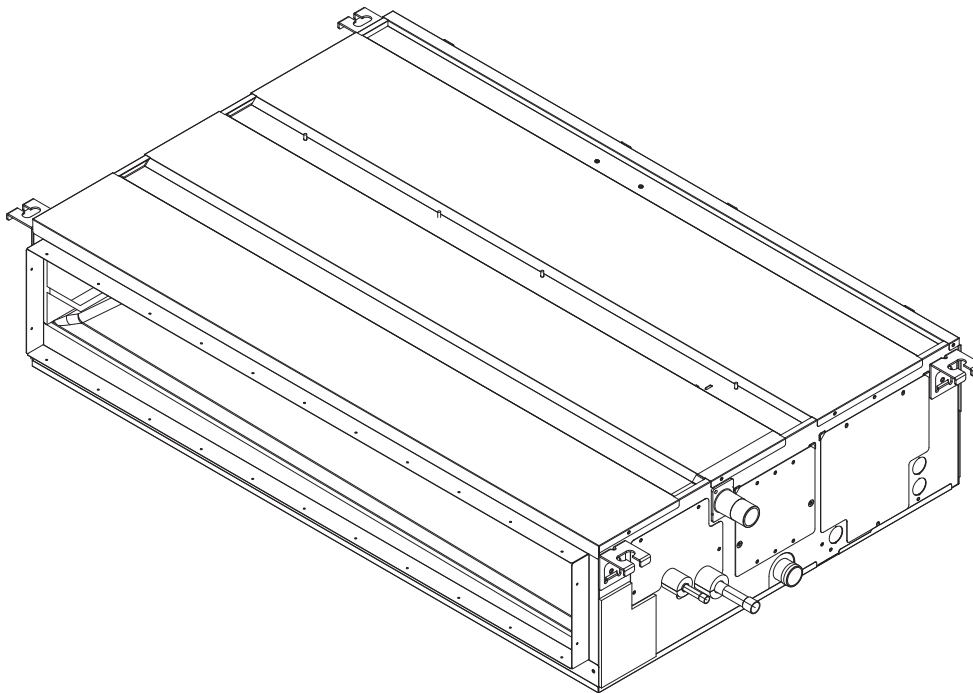

# CITY MULTI

# Safety Precautions

## Read before installation and performing electrical work

- Thoroughly read the following safety precautions prior to installation.
- Observe these safety precautions for your safety.
- This equipment may have adverse effects on the equipment on the same power supply system.
- Contact the local power authority before connecting to the system.

### Symbol explanations

#### **WARNING**

This symbol indicates that failure to follow the instructions exactly as stated poses the risk of serious injury or death.

#### **CAUTION**

This symbol indicates that failure to follow the instructions exactly as stated poses the risk of serious injury or damage to the unit.



Indicates an action that must be avoided.



Indicates important instructions.



Indicates a parts that requires grounding.



Indicates that caution must be taken with rotating parts. (This symbol is on the main unit label.) <Color: Yellow>



Indicates that the parts that are marked with this symbol pose a risk of electric shock. (This symbol is on the main unit label.) <Color: Yellow>

#### **WARNING**

Carefully read the labels affixed to the main unit.

#### **WARNING**

Ask your dealer or a qualified technician to install the unit.

Improper installation by the user may result in water leakage, electric shock, or fire.

Properly install the unit on a surface that can withstand its weight.

Unit installed on an unstable surface may fall and cause injury.

Only use specified cables. Securely connect each cable so that the terminals do not carry the weight of the cable.

Improperly connected cables may produce heat and start a fire.

Take appropriate safety measures against wind gusts and earthquakes to prevent the unit from toppling over.

Improper installation may cause the unit to topple over and cause injury or damage to the unit.

Only use accessories (i.e., air cleaners, humidifiers, electric heaters) recommended by Mitsubishi Electric.

Do not make any modifications or alterations to the unit. Consult your dealer for repair.

Improper repair may result in water leakage, electric shock, or fire.

Do not touch the heat exchanger fins with bare hands.

The fins are sharp and pose a risk of cuts.

In the event of a refrigerant leak, thoroughly ventilate the room.

If gaseous refrigerant leaks out and comes in contact with an open flame, toxic gases will be generated.

Properly install the unit according to the instructions in the Installation Manual.

Improper installation may result in water leakage, electric shock, or fire.

Have all electrical work performed by an authorized electrician according to the local regulations and the instructions in this manual. Use a dedicated circuit.

Insufficient power supply capacity or improper installation of the unit may result in malfunctions of the unit, electric shock, or fire.

## WARNING

Keep electrical parts away from water.

Wet electrical parts pose a risk of electric shock, smoke, or fire.

Securely attach the control box cover.

If the cover is not installed properly, dust or water may infiltrate and pose a risk of electric shock, smoke, or fire.

Only use the type of refrigerant that is indicated on the unit when installing or relocating the unit.

Infiltration of any other types of refrigerant or air into the unit may adversely affect the refrigerant cycle and may cause the pipes to burst or explode.

When installing the unit in a small space, take appropriate precautions to prevent leaked refrigerant from reaching the limiting concentration.

Leaked refrigerant gas will displace oxygen and may cause oxygen starvation. Consult your dealer before installing the unit.

Consult your dealer or a qualified technician when moving or reinstalling the unit.

Improper installation may result in water leakage, electric shock, or fire.

After completing the service work, check for a refrigerant leak.

If leaked refrigerant is exposed to a heat source, such as a fan heater, stove, or electric grill, toxic gases will be generated.

Do not try to defeat the safety features of the unit.

Forced operation of the pressure switch or the temperature switch by defeating the safety features for these devices, or the use of accessories other than the ones that are recommended by Mitsubishi Electric may result in smoke, fire, or explosion.

Consult your dealer for proper disposal method.

Do not use a leak detection additive.

## Precautions for handling units for use with R410A

### CAUTION

Do not use the existing refrigerant piping.

A large amount of chlorine that may be contained in the residual refrigerant and refrigerator oil in the existing piping may cause the refrigerator oil in the new unit to deteriorate.

Use refrigerant piping materials made of phosphorus deoxidized copper. Keep the inner and outer surfaces of the pipes clean and free of such contaminants as sulfur, oxides, dust, dirt, shaving particles, oil, and moisture.

Contaminants in the refrigerant piping may cause the refrigerator oil to deteriorate.

Store the piping materials indoors, and keep both ends of the pipes sealed until immediately before brazing. (Keep elbows and other joints wrapped in plastic.)

Infiltration of dust, dirt, or water into the refrigerant system may cause the refrigerator oil to deteriorate or cause the compressor to malfunction.

Use a small amount of ester oil, ether oil, or alkyl benzene to coat flares and flanges.

Infiltration of a large amount of mineral oil may cause the refrigerator oil to deteriorate.

Charge the system with refrigerant in the liquid phase.

If gaseous refrigerant is drawn out of the cylinder first, the composition of the remaining refrigerant in the cylinder will change and become unsuitable for use.

Only use R410A.

The use of other types of refrigerant that contain chloride may cause the refrigerator oil to deteriorate.

Use a vacuum pump with a check valve.

If a vacuum pump that is not equipped with a check valve is used, the vacuum pump oil may flow into the refrigerant cycle and cause the refrigerator oil to deteriorate.

Prepare tools for exclusive use with R 410A. Do not use the following tools if they have been used with the conventional refrigerant: gauge manifold, charging hose, gas leak detector, check valve, refrigerant charge base, vacuum gauge, and refrigerant recovery equipment.

If the refrigerant or the refrigerator oil that may be left on these tools are mixed in with R410A, it may cause the refrigerator oil in the new system to deteriorate.

Infiltration of water may cause the refrigerator oil to deteriorate. Leak detectors for conventional refrigerants will not detect an R410A leak because R410A is free of chlorine.

Do not use a charging cylinder.

If a charging cylinder is used, the composition of the refrigerant in the cylinder will change and become unsuitable for use.

Exercise special care when handling tools for use with R410A.

Infiltration of dust, dirt, or water into the refrigerant system may cause the refrigerator oil to deteriorate.

# CONTENTS

---

## I Features

[1] Features.....	1
-------------------	---

## II Components and Functions

[1] Components and Functions.....	2
-----------------------------------	---

## III Specifications

[1] Specifications.....	4
1.Specifications.....	4
2.Electrical component specifications.....	7

## IV Outlines and Dimensions

[1] Outlines and Dimensions.....	8
[2] Service Space.....	10

## V Wiring Diagram

[1] Wiring Diagram.....	11
-------------------------	----

## VI Refrigerant System Diagram

[1] Refrigerant system diagram.....	13
-------------------------------------	----

## VII Troubleshooting

[1] Troubleshooting.....	14
1.Check methods.....	14
2.DC fan motor (fan motor/indoor control board).....	18
3.Address switch setting.....	19
4.Voltage test points on the control board.....	20
5.Dipswitch setting (Factory setting).....	21

## VIII Disassembly Procedure

[1] Disassembly Procedure.....	24
1.Control box.....	24
2.Thermistor (Intake air).....	25
3.Drainpan.....	26
4.Thermistor (Gas pipe) (Liquid pipe).....	27
5.Fan and fan motor.....	28
6.Heat exchanger.....	29



**[1] Features**

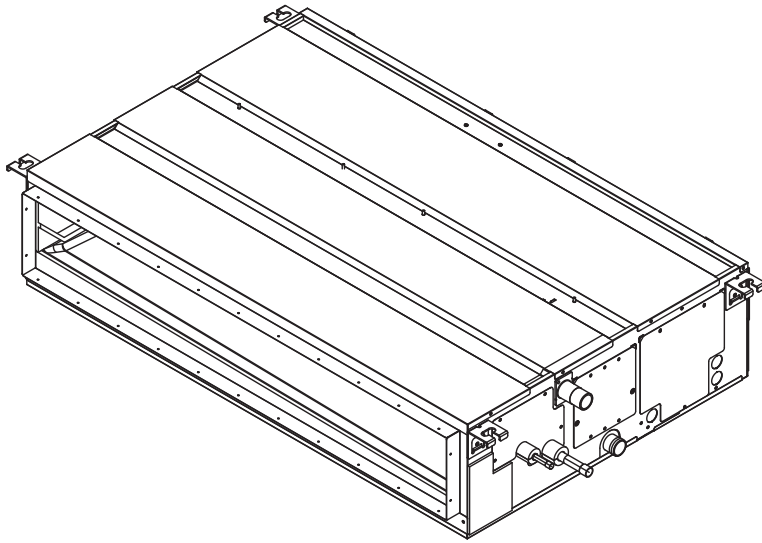

Model	Cooling capacity/Heating capacity
	kW
PEFY-P20VMA(L)-E	2.2/2.5
PEFY-P25VMA(L)-E	2.8/3.2
PEFY-P32VMA(L)-E	3.6/4.0
PEFY-P40VMA(L)-E	4.5/5.0
PEFY-P50VMA(L)-E	5.6/6.3
PEFY-P63VMA(L)-E	7.1/8.0
PEFY-P71VMA(L)-E	8.0/9.0
PEFY-P80VMA(L)-E	9.0/10.0
PEFY-P100VMA(L)-E	11.2/12.5
PEFY-P125VMA(L)-E	14.0/16.0
PEFY-P140VMA(L)-E	16.0/18.0

## [1] Components and Functions

### 1. Indoor (Main) Unit

(1) In case of rear inlet

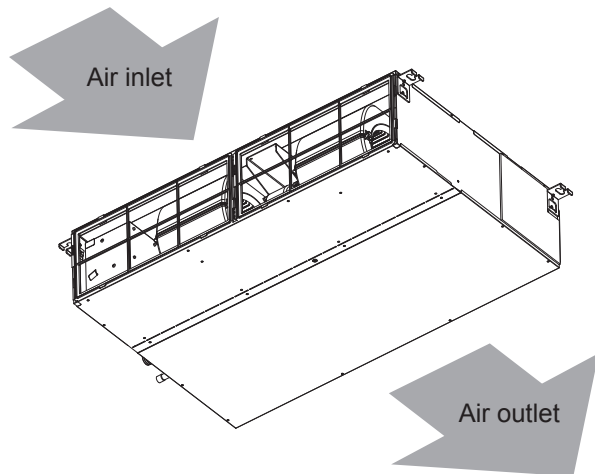

(2) In case of bottom inlet

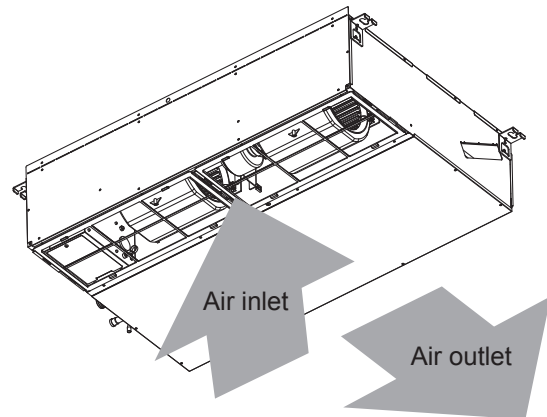

### 2. Remote Controller

[PAR-21MAA]

Once the operation mode is selected, the unit will remain in the selected mode until changed.

#### (1) Remote Controller Buttons

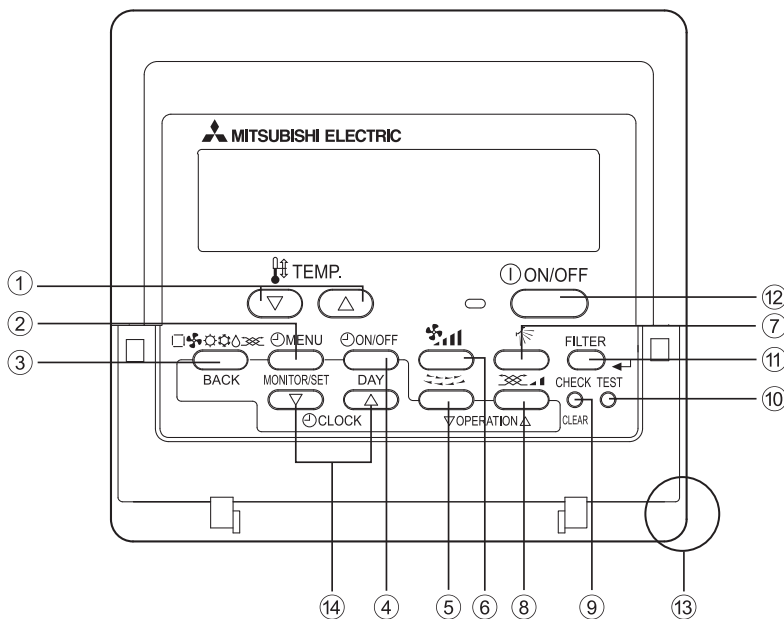

- |                            |   |
|----------------------------|---|
| 1 [Set Temperature] Button | 7 [Vane Control] Button                 |
| 2 [Timer Menu] Button      | 8 [Ventilation] Button                  |
| [Monitor/Set] Button       | [Operation] Button                      |
| 3 [Mode] Button            | 9 [Check/Clear] Button                  |
| [Back] Button              | 10 [Test Run] Button                    |
| 4 [Timer On/Off] Button    | 11 [Filter] Button                      |
| [Set Day] Button           | [ ] Button                              |
| 5 [Louver] Button          | 12 [ON/OFF] Button                      |
| [Operation] Button         | 13 Position of built-in room thermistor |
| 6 [Fan Speed] Button       | 14 [Set Time] Button                    |

- Keep the remote controller out of direct sunlight to ensure accurate measurement of room temperature.
- The thermistor at the lower right-hand section of the remote controller must be free from obstructions to ensure accurate measurement of room temperature.

(2) Remote Controller Display

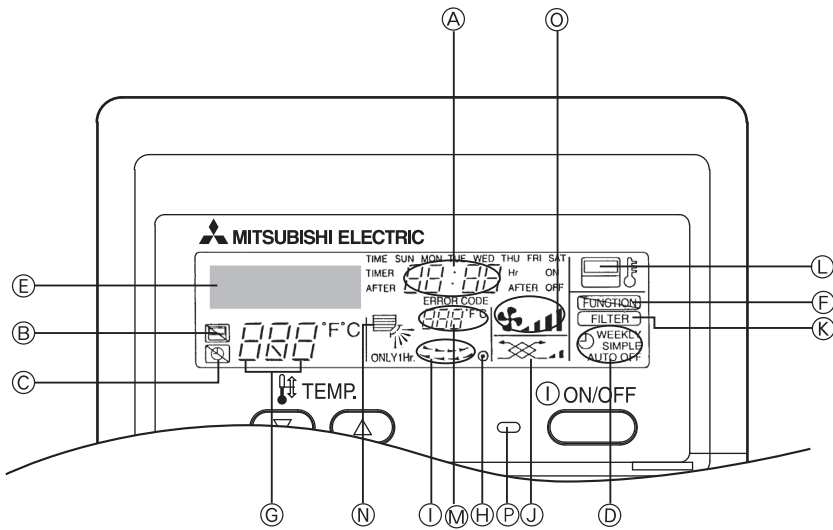

- |   |   |   |                  |
|---|---|---|------------------|
| A | Current time/Timer time                                 | I | Louver swing     |
| B | Centralized control indicator                           | J | Ventilation      |
| C | Timer OFF indicator                                     | K | Filter sign      |
| D | Timer mode indicator                                    | L | Sensor position  |
| E | Operation mode display:  COOL,  DRY,  AUTO,  FAN,  HEAT | M | Room temperature |
| F | Function mode indicator                                 | N | Vane setting     |
| G | Preset temperature                                      | O | Fan speed        |
| H | Power indicator   | P | Operation lamp   |



**[1] Specifications**

**1. Specifications**

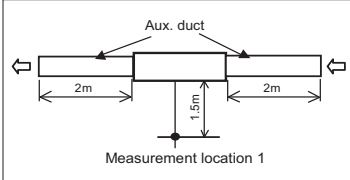
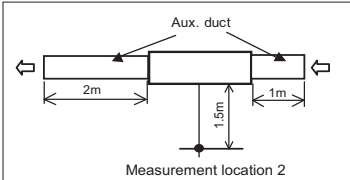
Model			PEFY-P20VMA(L)-E	PEFY-P25VMA(L)-E	PEFY-P32VMA(L)-E	PEFY-P40VMA(L)-E
Power supply	Voltage	V	1-phase 220-230-240			
	Frequency	Hz	50/60			
Cooling capacity *1		kW	2.2	2.8	3.6	4.5
Heating capacity *1		kW	2.5	3.2	4.0	5.0
Power consumption *2	Cooling	kW	0.06(0.04)		0.07(0.05)	0.09(0.07)
	Heating	kW	0.04(0.04)		0.05(0.05)	0.07(0.07)
Current consumption *2	Cooling	A	0.53(0.42)		0.55(0.44)	0.64(0.53)
	Heating	A	0.42(0.42)		0.44(0.44)	0.53(0.53)
External finish			Galvanized			
Dimensions	Height	mm	250			
	Width	mm	700			900
	Depth	mm	732			
Net weight *2		kg	23(22)			26(25)
Heat exchanger			Cross fin(Aluminium fin and copper tube)			
Fan	Type		Sirocco fan x 1			
	Airflow rate (Low-Mid-High)	m <sup>3</sup> /min	6.0-7.5-8.5		7.5-9.0-10.5	10.0-12.0-14.0
	External static pressure	Pa	35/50/70/100/150			
Motor	Output	kW	0.085			
Air filter			PP Honeycomb fabric (washable)			
Refrigerant pipe dimensions	Gas (Brazed connection)	mm[in.]	ø12.7[ø1/2]			
	Liquid (Brazed connection)	mm[in.]	ø6.35[ø1/4]			
Drain pipe dimensions		mm[in.]	O.D. 32[1-1/4]			
Operating noise(Low-Mid-High)  * Measured in anechoic room.  * Measured in anechoic room.	35Pa	dB (A)	23-24-25		23-25-28	23-26-29
	50Pa		23-25-26		23-26-29	23-27-30
	70Pa		23-26-28		24-27-30	24-28-31
	100Pa		24-27-30		25-28-32	26-29-33
	150Pa		25-30-34		28-32-36	29-33-37
	35Pa		26-27-28		28-30-34	
	50Pa		26-28-29		28-30-34	
	70Pa		26-29-31		29-32-36	
	100Pa		27-30-33		29-33-37	
	150Pa		28-33-37		31-35-40	32-36-40

\*1 <Cooling> Indoor temperature: 27°CDB/19°CWB (81°FDB/66°FWB) Outdoor temperature: 35°CDB (95°FDB)  
 <Heating> Indoor temperature: 20°CDB (68°FWB) Outdoor temperature: 7°CDB/6°CWB (45°FDB/43°FWB)

\*2 Figures in the parentheses indicate drainpump-less Model (L).

[ III Specifications ]

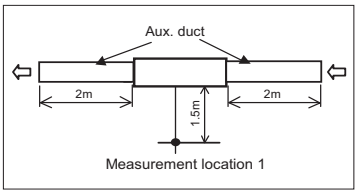
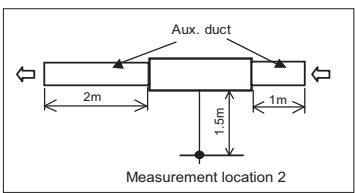
Model			PEFY-P50VMA(L)-E	PEFY-P63VMA(L)-E	PEFY-P71VMA(L)-E	PEFY-P80VMA(L)-E
Power supply	Voltage	V	1-phase 220-230-240			
	Frequency	Hz	50/60			
Cooling capacity *1		kW	5.6	7.1	8.0	9.0
Heating capacity *1		kW	6.3	8.0	9.0	10.0
Power consumption *2	Cooling	kW	0.11(0.09)	0.12(0.10)	0.14(0.12)	
	Heating	kW	0.09(0.09)	0.10(0.10)	0.12(0.12)	
Current consumption *2	Cooling	A	0.74(0.63)	1.01(0.90)	1.15(1.04)	
	Heating	A	0.63(0.63)	0.90(0.90)	1.04(1.04)	
External finish			Galvanized			
Dimensions	Height	mm	250			
	Width	mm	900	1100		
	Depth	mm	732			
Net weight *2		kg	26(25)	32(31)		
Heat exchanger			Cross fin(Aluminium fin and copper tube)			
Fan	Type		Sirocco fan x 1	Sirocco fan x 2		
	Airflow rate (Low-Mid-High)	m <sup>3</sup> /min	12.0-14.5-17.0	13.5-16.0-19.0	14.5-18.0-21.0	
	External static pressure	Pa	35/50/70/100/150			
Motor	Output	kW	0.085	0.121		
Air filter			PP Honeycomb fabric (washable)			
Refrigerant pipe dimensions	Gas (Braze connection)	mm[in.]	ø12.7[ø1/2]	ø15.88[ø5/8]		
	Liquid (Braze connection)	mm[in.]	ø6.35[ø1/4]	ø9.52[ø3/8]		
Drain pipe dimensions		mm[in.]	O.D. 32[1-1/4]			
Operating noise(Low-Mid-High)						
 <p>* Measured in anechoic room.</p>		35Pa	dB (A)	24-28-31	25-28-32	26-29-33
		50Pa		25-29-32	25-29-33	26-29-34
		70Pa		26-30-33	26-30-34	26-30-35
		100Pa		27-31-34	27-31-35	29-33-37
		150Pa		29-34-38		32-37-41
		35Pa		28-31-35	29-32-35	30-33-37
		50Pa		28-32-35	29-32-36	30-34-38
		70Pa		29-33-37	30-33-38	31-36-39
		100Pa		30-34-38	31-35-39	33-37-41
		150Pa		32-37-41	33-38-41	36-41-44
 <p>* Measured in anechoic room.</p>		35Pa		28-31-35	29-32-35	30-33-37
		50Pa		28-32-35	29-32-36	30-34-38
		70Pa		29-33-37	30-33-38	31-36-39
		100Pa		30-34-38	31-35-39	33-37-41
		150Pa		32-37-41	33-38-41	36-41-44

\*1 <Cooling> Indoor temperature: 27°CDB/19°CWB (81°FDB/66°FWB) Outdoor temperature: 35°CDB (95°FDB)

<Heating> Indoor temperature: 20°CDB (68°FWB) Outdoor temperature: 7°CDB/6°CWB (45°FDB/43°FWB)

\*2 Figures in the parentheses indicate drainpump-less Model (L).

[ III Specifications ]

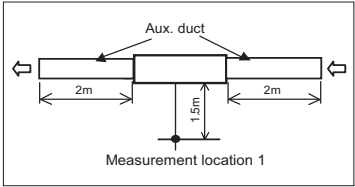
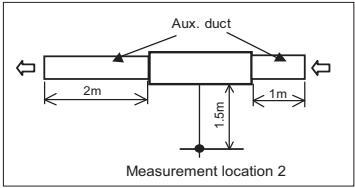
Model			PEFY-P100VMA(L)-E	PEFY-P125VMA(L)-E	PEFY-P140VMA(L)-E
Power supply	Voltage	V	1-phase 220-230-240		
	Frequency	Hz	50/60		
Cooling capacity *1		kW	11.2	14.0	16.0
Heating capacity *1		kW	12.5	16.0	18.0
Power consumption *2	Cooling	kW	0.24(0.22)	0.34(0.32)	0.36(0.34)
	Heating	kW	0.22(0.22)	0.32(0.32)	0.34(0.34)
Current consumption *2	Cooling	A	1.47(1.36)	2.05(1.94)	2.21(2.10)
	Heating	A	1.36(1.36)	1.94(1.94)	2.10(2.10)
External finish			Galvanized		
Dimensions	Height	mm	250		
	Width	mm	1400	1600	
	Depth	mm	732		
Net weight *2		kg	42(41)	46(45)	
Heat exchanger			Cross fin(Aluminium fin and copper tube)		
Fan	Type		Sirocco fan x 2		
	Airflow rate (Low-Mid-High)	m <sup>3</sup> /min	23.0-28.0-33.0	28.0-34.0-40.0	29.5-35.5-42.0
	External static pressure	Pa	35/50/70/100/150		
Motor	Output	kW	0.244		
Air filter			PP Honeycomb fabric (washable)		
Refrigerant pipe dimensions	Gas (Brazed connection)	mm[in.]	ø15.88[ø5/8]		
	Liquid (Brazed connection)	mm[in.]	ø9.52[ø3/8]		
Drain pipe dimensions		mm[in.]	O.D. 32[1-1/4]		
Operating noise(Low-Mid-High)  * Measured in anechoic room.  * Measured in anechoic room.	35Pa	dB (A)	28-32-36	31-35-39	31-35-40
	50Pa		28-33-37	32-36-40	33-37-42
	70Pa		30-35-39	32-37-41	34-38-43
	100Pa		31-36-40	33-39-42	35-39-44
	150Pa		33-38-43	37-40-44	37-41-45
	35Pa		31-36-40	35-40-44	36-41-45
	50Pa		32-37-41	35-40-44	36-41-45
	70Pa		33-38-42	37-41-45	38-42-46
	100Pa		35-39-43	38-42-46	39-43-47
	150Pa		37-42-45	39-44-47	40-45-48

\*1 <Cooling> Indoor temperature: 27°CDB/19°CWB (81°FDB/66°FWB) Outdoor temperature: 35°CDB (95°FDB)  
 <Heating> Indoor temperature: 20°CDB (68°FWB) Outdoor temperature: 7°CDB/6°CWB (45°FDB/43°FWB)

\*2 Figures in the parentheses indicate drainpump-less Model (L).

## 2. Electrical component specifications

Component	Symbol	PEFY-P20VMA(L)-E	PEFY-P25VMA(L)-E	PEFY-P32VMA(L)-E
Room temperature thermistor	TH21	Resistance 0°C/15kΩ, 10°C/9.6kΩ, 20°C/6.3kΩ, 25°C/5.4kΩ, 30°C/4.3kΩ, 40°C/3.0kΩ		
Liquid pipe thermistor	TH22	Resistance 0°C/15kΩ, 10°C/9.6kΩ, 20°C/6.3kΩ, 25°C/5.4kΩ, 30°C/4.3kΩ, 40°C/3.0kΩ		
Gas pipe thermistor	TH23	Resistance 0°C/15kΩ, 10°C/9.6kΩ, 20°C/6.3kΩ, 25°C/5.4kΩ, 30°C/4.3kΩ, 40°C/3.0kΩ		
Fuse	FUSE	250V 6.3A		
Fan motor		8-pole, Output 85W SIC-70CW-D885-1		
Linear expansion valve	LEV	12VDC Stepping motor drive port diameter ø3.2 (0~2000 pulse)		
Power supply terminal block	TB2	(L, N, ⊕) 250V 20A		
Transmission terminal block	TB5 TB15	(1, 2) 250V 15A, (M1, M2, S) 250V 20A		
Drain float switch	DS	Open/short detection Initial contact resistance 500 mΩ or less		

Component	Symbol	PEFY-P40VMA(L)-E	PEFY-P50VMA(L)-E	PEFY-P63VMA(L)-E	PEFY-P71VMA(L)-E	PEFY-P80VMA(L)-E
Room temperature thermistor	TH21	Resistance 0°C/15kΩ, 10°C/9.6kΩ, 20°C/6.3kΩ, 25°C/5.4kΩ, 30°C/4.3kΩ, 40°C/3.0kΩ				
Liquid pipe thermistor	TH22	Resistance 0°C/15kΩ, 10°C/9.6kΩ, 20°C/6.3kΩ, 25°C/5.4kΩ, 30°C/4.3kΩ, 40°C/3.0kΩ				
Gas pipe thermistor	TH23	Resistance 0°C/15kΩ, 10°C/9.6kΩ, 20°C/6.3kΩ, 25°C/5.4kΩ, 30°C/4.3kΩ, 40°C/3.0kΩ				
Fuse	FUSE	250V 6.3A				
Fan motor		8-pole, Output 85W SIC-70CW-D885-2		8-pole, Output 121W SIC-70CW-D8121-1		
Linear expansion valve	LEV	12VDC Stepping motor drive port diameter ø3.2 (0~2000 pulse)				
Power supply terminal block	TB2	(L, N, ⊕) 250V 20A				
Transmission terminal block	TB5 TB15	(1, 2) 250V 15A, (M1, M2, S) 250V 20A				
Drain float switch	DS	Open/short detection Initial contact resistance 500 mΩ or less				

Component	Symbol	PEFY-P100VMA(L)-E	PEFY-P125VMA(L)-E	PEFY-P140VMA(L)-E
Room temperature thermistor	TH21	Resistance 0°C/15kΩ, 10°C/9.6kΩ, 20°C/6.3kΩ, 25°C/5.4kΩ, 30°C/4.3kΩ, 40°C/3.0kΩ		
Liquid pipe thermistor	TH22	Resistance 0°C/15kΩ, 10°C/9.6kΩ, 20°C/6.3kΩ, 25°C/5.4kΩ, 30°C/4.3kΩ, 40°C/3.0kΩ		
Gas pipe thermistor	TH23	Resistance 0°C/15kΩ, 10°C/9.6kΩ, 20°C/6.3kΩ, 25°C/5.4kΩ, 30°C/4.3kΩ, 40°C/3.0kΩ		
Fuse	FUSE	250V 6.3A		
Fan motor		8-pole, Output 244W SIC-101CW-D8244-1		
Linear expansion valve	LEV	12VDC Stepping motor drive port diameter ø3.2 (0~2000 pulse)		
Power supply terminal block	TB2	(L, N, ⊕) 250V 20A		
Transmission terminal block	TB5 TB15	(1, 2) 250V 15A, (M1, M2, S) 250V 20A		
Drain float switch	DS	Open/short detection Initial contact resistance 500 mΩ or less		

**[1] Outlines and Dimensions**

1. PEFY-P20, 25, 32, 40, 50, 63, 71, 80, 100, 125, 140VMA-E

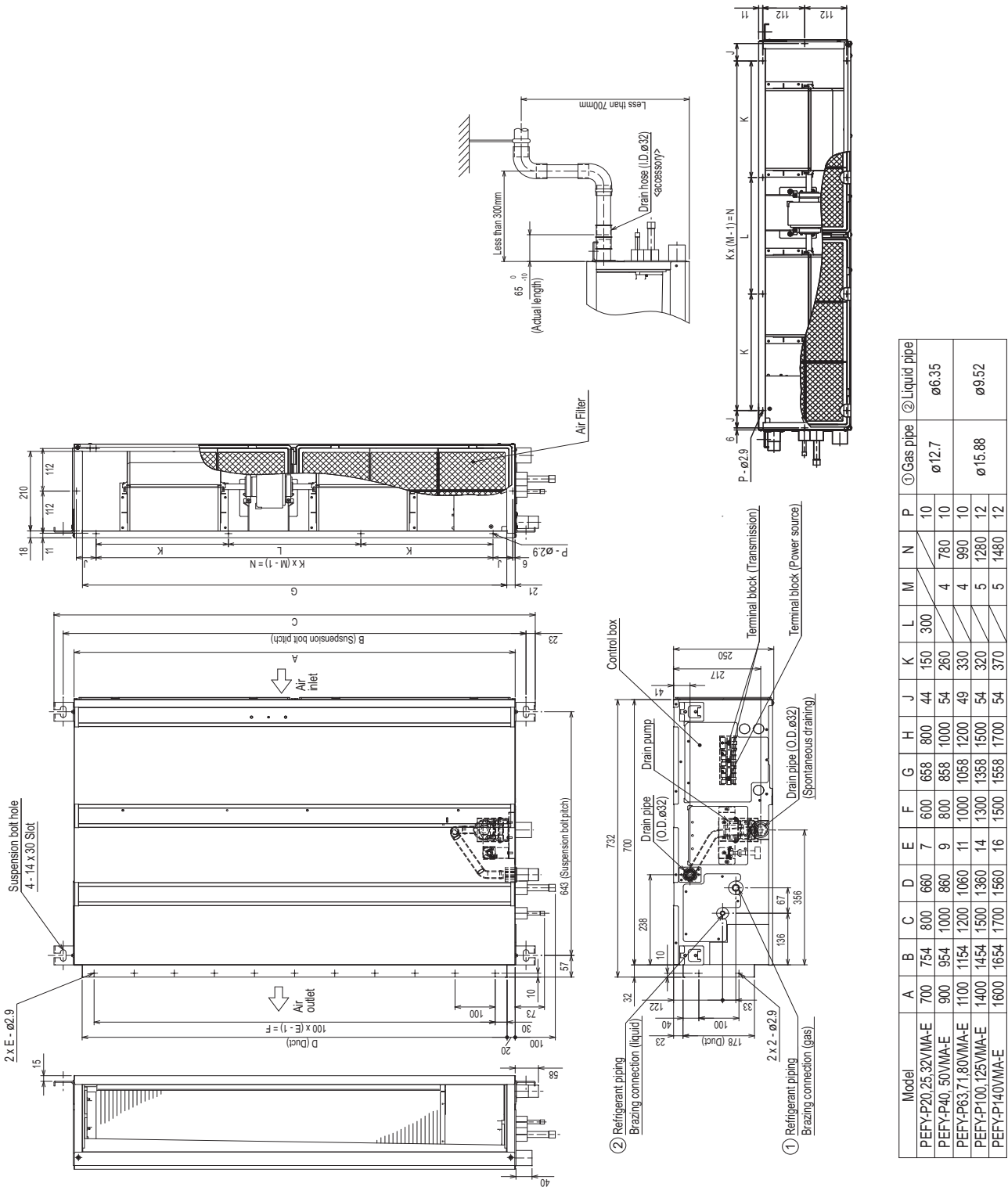

- Note
- 1 Use M10 suspension bolts. (not supplied)
  - 2 Provide an access door for maintenance at the bottom.
  - 3 The dimensions in the table are those of the PEFY-P63, 71, 80, 100, 125, 140VMA-E models, which have 2 fans. The PEFY-P20~50VMA-E model have 1 fans.
  - 4 To connect an intake duct, uninstall the air filter on the unit, and install a locally procured air filter on the intake duct on the intake side.

2. PEFY-P20, 25, 32, 40, 50, 63, 71, 80, 100, 125, 140VMAL-E

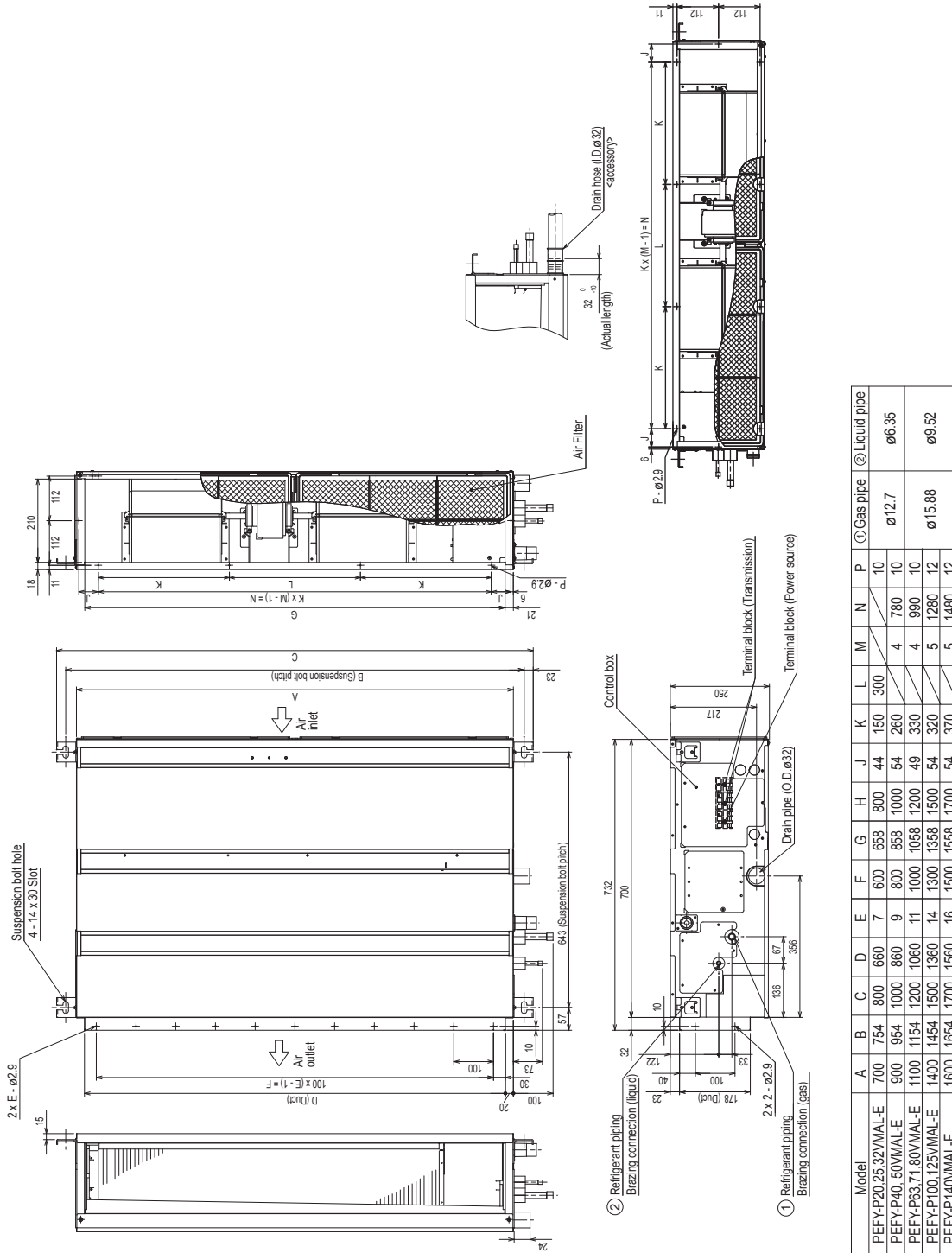

- Note
- 1 Use M10 suspension bolts. (not supplied)
  - 2 Provide an access door for maintenance at the bottom.
  - 3 The dimensions in the table are those of the PEFY-P63, 71, 80, 100, 125, 140VMAL-E models, which have 2 fans. The PEFY-P20~50VMAL-E model have 1 fans.
  - 4 To connect an intake duct, uninstall the air filter on the unit, and install a locally procured air filter on the intake duct on the intake side.

**[2] Service Space**

**1. PEFY-P20, 25, 32, 40, 50, 63, 71, 80, 100, 125, 140VMA(L)-E**

Secure enough access space to allow for the maintenance, inspection, and replacement of the motor, fan, drain pump, heat exchanger, and electric box in one of the following ways.

Select an installation site for the indoor unit so that its maintenance access space will not be obstructed by beams or other objects.

(1) When a space of 300 mm or more is available below the unit between the unit and the ceiling (Fig. 1)

- Create access door 1 and 2 (450 × 450 mm each) as shown in Fig. 2.

(Access door 2 is not required if enough space is available below the unit for a maintenance worker to work in.)

(2) When a space of less than 300 mm is available below the unit between the unit and the ceiling (At least 20 mm of space should be left below the unit as shown in Fig. 3.)

- Create access door 1 diagonally below the electric box and access door 3 below the unit as shown in Fig. 4.

or

- Create access door 4 below the electric box and the unit as shown in Fig. 5.

Model	Q	R	S	T
PEFY-P20, 25, 32VMA(L)-E	700	50~150	800	1300
PEFY-P40, 50VMA(L)-E	900	150~250	1000	1500
PEFY-P63, 71, 80VMA(L)-E	1100	250~350	1200	1700
PEFY-P100, 125VMA(L)-E	1400	400~500	1500	2000
PEFY-P140VMA(L)-E	1600	500~600	1700	2200

Unit: mm

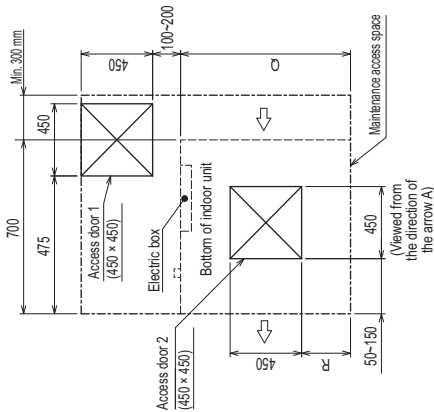

Fig. 2

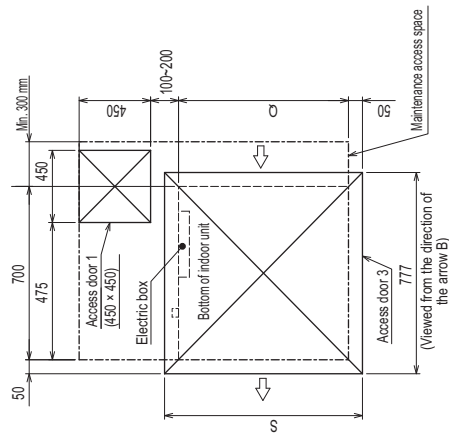

Fig. 4

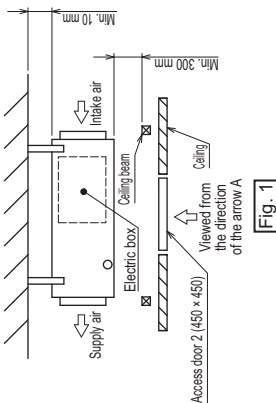

Fig. 1

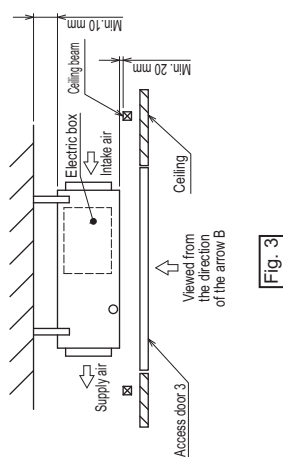

Fig. 3

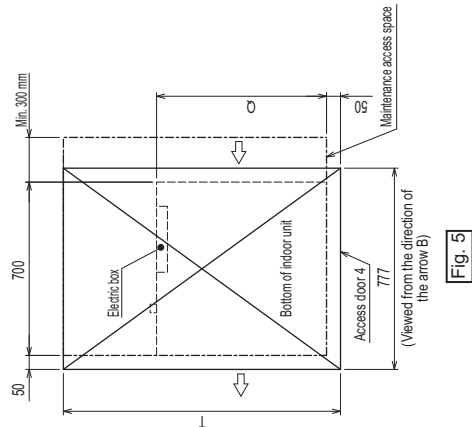

Fig. 5

**[1] Wiring Diagram**

1. PEFY-P20, 25, 32, 40, 50, 63, 71, 80, 100, 125, 140VMA(L)-E

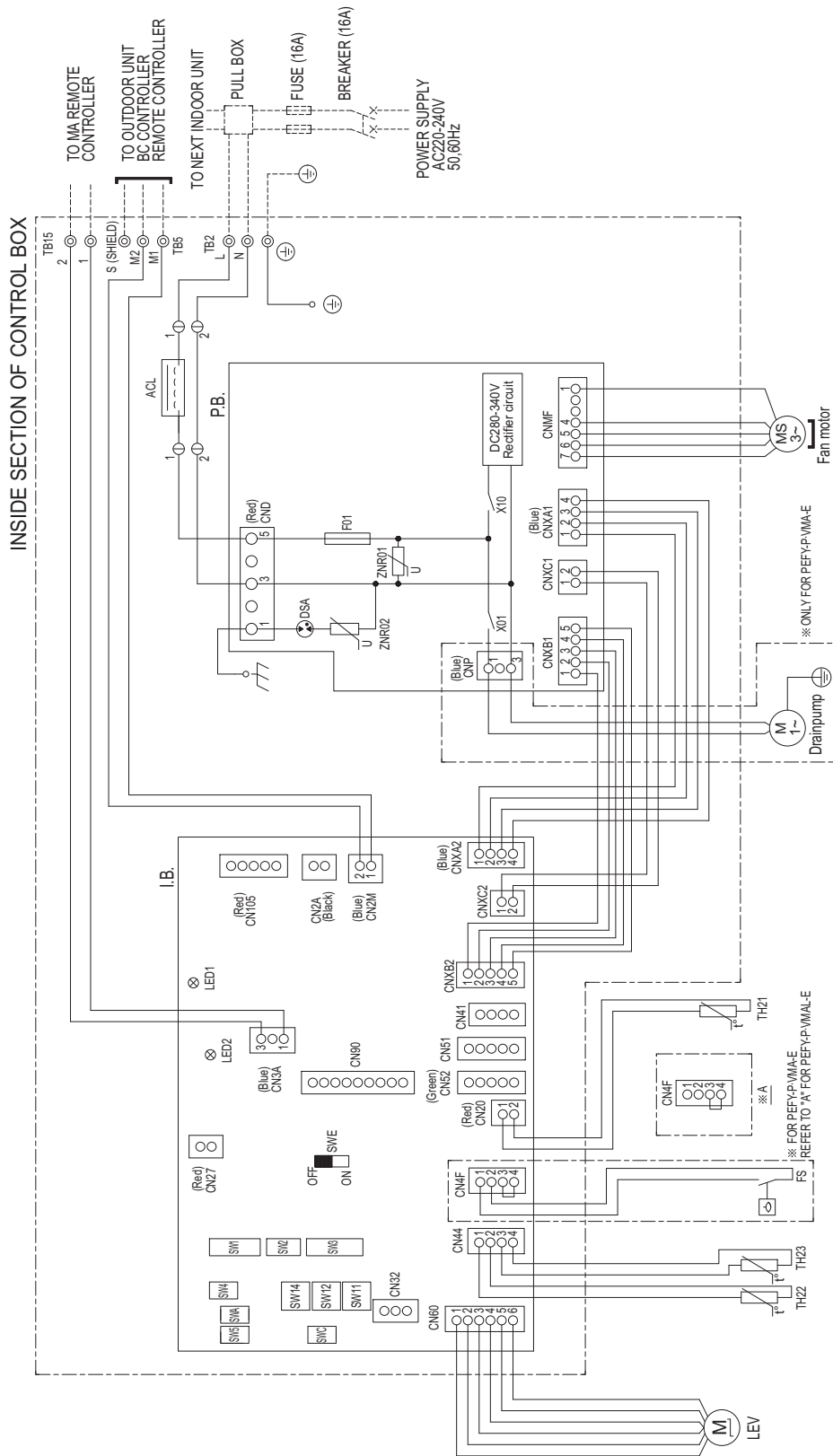

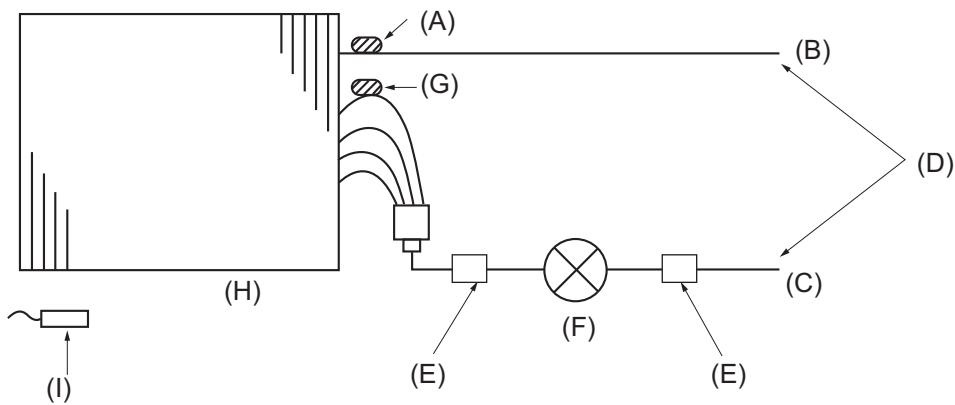

Table.1 SYMBOL EXPLANATION

SYM-BOL	NAME	SYM-BOL	NAME	SYM-BOL	NAME
I.B.	Indoor controller board	CN32	Connector (Remote switch)	SW2 (I.B.)	Switch (for capacity code)
P.B.	Power supply board	CN41	Connector (HA terminal-A)	SW3 (I.B.)	Switch (for mode selection)
TB2	Power source terminal block	CN51	Connector (Centrally control)	SW4 (I.B.)	Switch (for model selection)
TB5	Transmission terminal block	CN52	Connector (Remote indication)	SW5 (I.B.)	Switch (for mode selection)
TB15	Transmission terminal block	CN90	Connector (Wireless)	SWE (I.B.)	Connector (emergency operation)
F01	Fuse AC 250V 6.3A	CN105	Connector (IT terminal)	SW11 (I.B.)	Switch (1s digit address set)
ZNR01, 02	Varistor	CN2A	Connector (0-10V Analog input)	SW12 (I.B.)	Switch (10ths digit address set)
DSA	Arrester	FS	Float switch	SW14 (I.B.)	Switch (BRANCH No.)
X01	Aux. relay	TH21	Thermistor (inlet air temp. detection)	SWA (I.B.)	Switch (for static pressure selection)
X10	Aux. relay	TH22	Thermistor (piping temp. detection / liquid)	SWC (I.B.)	Switch (for static pressure selection)
ACL	AC reactor (Power factor improvement)	TH23	Thermistor (piping temp. detection / gas)		
CN27	Connector (Damper)	SW1 (I.B.)	Switch (for mode selection)		

- Note 1 Wiring to TB2, TB5, and TB15 indicated by the double-dashed lines is on-site work.  
 2 ⊙ terminal block, ⊖ connector.

**[1] Refrigerant system diagram**



- (A) Gas pipe thermistor TH23
- (B) Gas pipe
- (C) Liquid pipe
- (D) Brazed connections
- (E) Strainer (#100 mesh)
- (F) Linear expansion valve
- (G) Liquid pipe thermistor TH22
- (H) Heat exchanger
- (I) Room temperature thermistor TH21

Capacity	PEFY- P20, 25, 32, 40, 50VMA(L)-E	PEFY- P63, 71, 80, 100, 125, 140VMA(L)-E
Gas pipe	ø12.7 [1/2]	ø15.88 [5/8]
Liquid pipe	ø6.35 [1/4]	ø9.52 [3/8]

## [1] Troubleshooting

### 1. Check methods

#### 1. Component and check points

##### (1) Thermistor

- Room temperature thermistor (TH21)
- Liquid pipe thermistor (TH22)
- Gas pipe thermistor (TH23)

Disconnect the connector and measure the resistance between terminals with a tester.  
(Ambient temperature 10°C - 30°C)

Normal	Abnormal
4.3kΩ - 9.6kΩ	Open or short

(Refer to the thermistor characteristic graph below.)

##### 1) Thermistor characteristic graph

###### Low-temperature thermistor

- Room temperature thermistor (TH21)
- Liquid pipe thermistor (TH22)
- Gas pipe thermistor (TH23)
- Drain sensor (DS)

- Thermistor  $R_0 = 15 \text{ k}\Omega \pm 3\%$
- Multiplier of B =  $3480 \text{ k}\Omega \pm 2\%$

$$R_t = 15 \exp \left\{ 3480 \left( \frac{1}{273+t} - \frac{1}{273} \right) \right\}$$

- 0°C 15kΩ
- 10°C 9.6kΩ
- 20°C 6.3kΩ
- 25°C 5.2kΩ
- 30°C 4.3kΩ
- 40°C 3.0kΩ

(A) Temperature (°C)

(B) Resistance (kΩ)

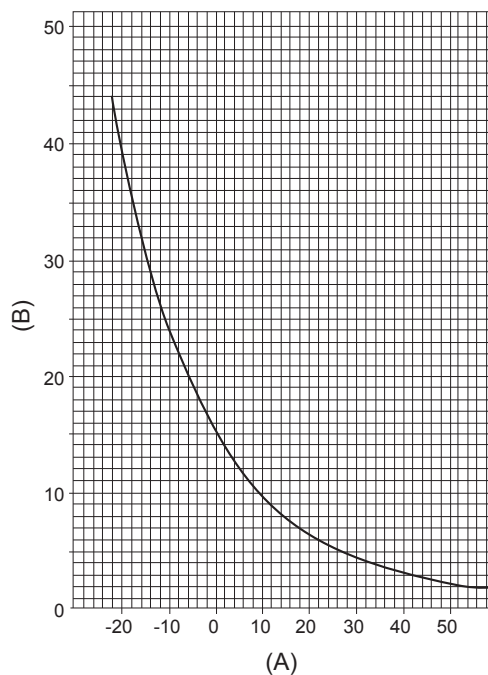

##### (2) Fan motor (CNMF)

Refer to the page on "DC fan motor (fan motor/indoor control board)."

##### (3) Linear expansion valve

Disconnect the connector, and measure the resistance between terminals with a tester.  
Refer to the next page for details.

	Normal				Abnormal
	1-5 White-Red	2-6 Yellow-Brown	3-5 Orange-Red	4-6 Blue-Brown	
200 kΩ ± 10%					

- (A) Brown
- (B) Red
- (C) Blue
- (D) Orange
- (E) Yellow
- (F) White

1) Summary of linear expansion valve (LEV) operation

- The LEV is operated by a stepping motor, which operates by receiving a pulse signal from the indoor control board.
- The LEV position changes in response to the pulse signal.

**Indoor control board and LEV connection**

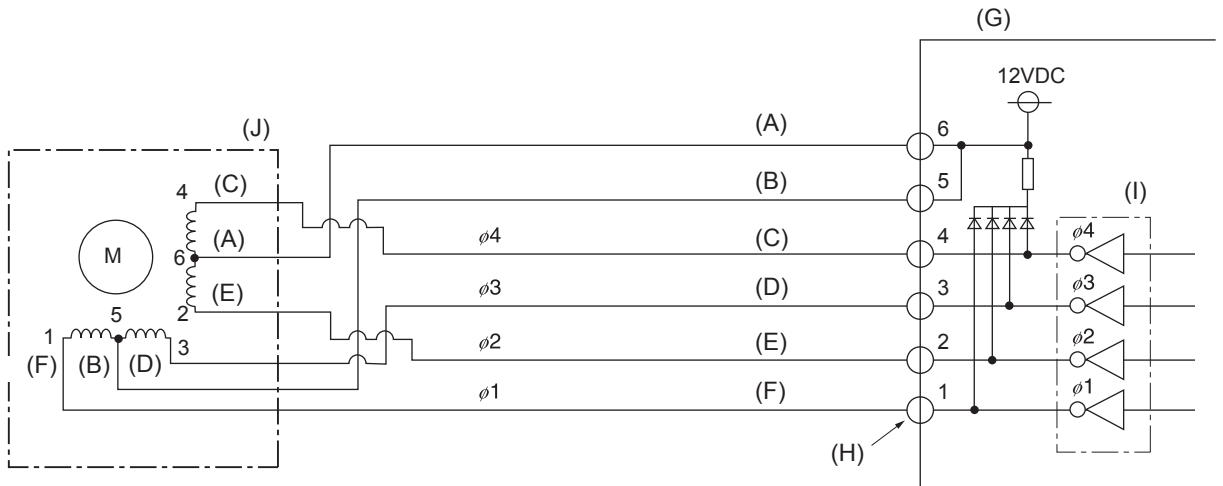

- |            |                            |
|------------|----------------------------|
| (A) Brown  | (F) White                  |
| (B) Red    | (G) Control board          |
| (C) Blue   | (H) Connection (CN60)      |
| (D) Orange | (I) Drive circuit          |
| (E) Yellow | (J) Linear expansion valve |

**Pulse signal output and valve operation**

Phase number	Output pulse			
	1	2	3	4
ø1	ON	OFF	OFF	ON
ø2	ON	ON	OFF	OFF
ø3	OFF	ON	ON	OFF
ø4	OFF	OFF	ON	ON

The output pulse changes in the following order:

When the valve closes 1 -> 2 -> 3 -> 4 -> 1

When the valve opens 4 -> 3 -> 2 -> 1 -> 4

- When the valve position remains the same, all output signals will be OFF.
- If any output signal is missing or if the signal remains ON, the motor vibrates and makes clicking noise.

2) LEV operation

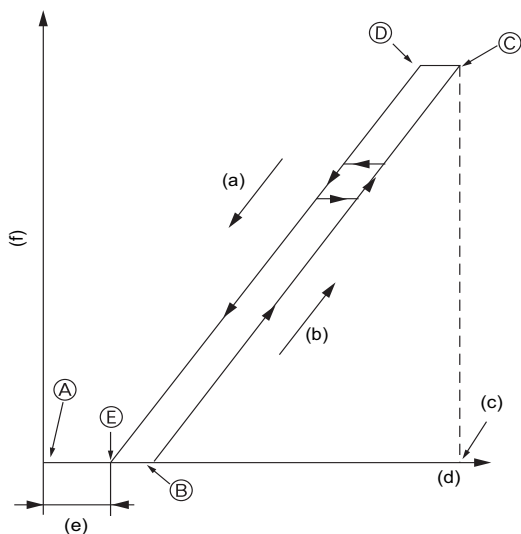

- (a) Close
- (b) Open
- (c) Fully open valve (2000 pulses)
- (d) No. of pulses
- (e) Extra tightning (80 - 100 pulse)
- (f) Valve opening degree

- When the power is turned on, a pulse signal of 2200 pulses is output (valve closure signal), to bring the valve to position A.
- When the valve is operating normally, it is free of vibration noise. If the valve locks or when it goes from point E to A in the figure, it makes louder noise than would be heard when there is an open phase.
- Check for abnormal sound/vibration by placing the metal tip of a screwdriver against the valve and the handle side against your ear.

3) Troubleshooting

Symptom	Checking Criteria	Remedy
Circuit failure on the microcomputer	Disconnect the connectors on the control board, and connect LEDs to test the circuit as shown below. <p>Pulse signals are output for 10 seconds when the main power is turned on. If there are LEDs that do not light up at all or remain lit after the pulses are turned off, there is a problem with the driving circuit.</p>	Replace the indoor control board if driving circuit failure is detected.
Locked LEV	The motor will idle and make small clicking noise if it is run while the LEV is locked. If this clicking noise is heard both when the valve is fully closed and while it is being opened, it indicates a problem.	Replace the LEV.
Disconnected or shorted LEV motor coils	Measure the resistance between the coils with a tester (red-white, red-orange, brown-yellow, brown-blue). The normal range of resistance is $150 \Omega \pm 10\%$	Replace the LEV.

Symptom	Checking Criteria	Remedy
Valve closure failure (leaky valve)	<p>To check the LEV on the indoor unit, check the indoor unit liquid pipe temperature that appears on the operation monitor on the outdoor unit's multi control board while operating the indoor unit in question in the FAN mode and the other indoor units in the cooling mode.</p> <p>(A) Termistor (TH21)</p> <p>Normally, the LEV is fully closed while the unit is in the FAN mode. If the valve is leaky, liquid pipe thermistor reading will be lower than normal. If it is significantly lower than the inlet temperature on the remote controller, valve closure failure is suspected. If the amount of leakage is insignificant, replacement of LEV is unnecessary unless it is causing a problem.</p>	Replace the LEV if the amount of leakage is great.
Misconnections of connectors or contact failure	<p>Perform a visual check for disconnected connectors.</p> <p>Perform a visual check of lead wire color.</p>	Disconnect the connectors on the control board and perform a continuity test.

(4) Drain-up mechanism

Measure the resistance between the terminals with a tester.  
(coil temperature 20°C)

	Normal	Abnormal
	340 Ω	Open or short

(5) Drain float switch (CN4F)

Disconnect the connector, and measure the resistance between terminals with a tester.

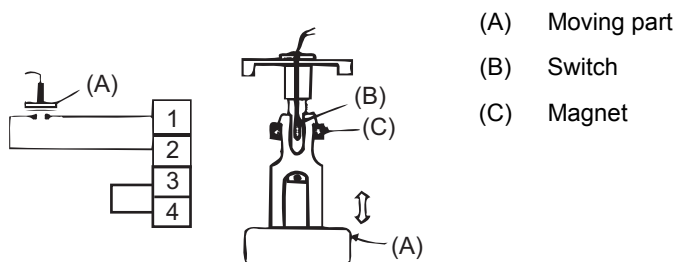

Position of the moving part	Normal	Abnormal
Up	Short	(any position but short)
Down	Open	(any position but open)

## 2. DC fan motor (fan motor/indoor control board)

### 1. CAUTION

- A high voltage is applied to the connector for connection to the fan motor (CNMF).
- Do not unplug the connector CNMF with the unit energized to avoid damage to the indoor control board and fan motor.

### 2. Troubleshooting

- Symptom: Indoor unit fan does not run.

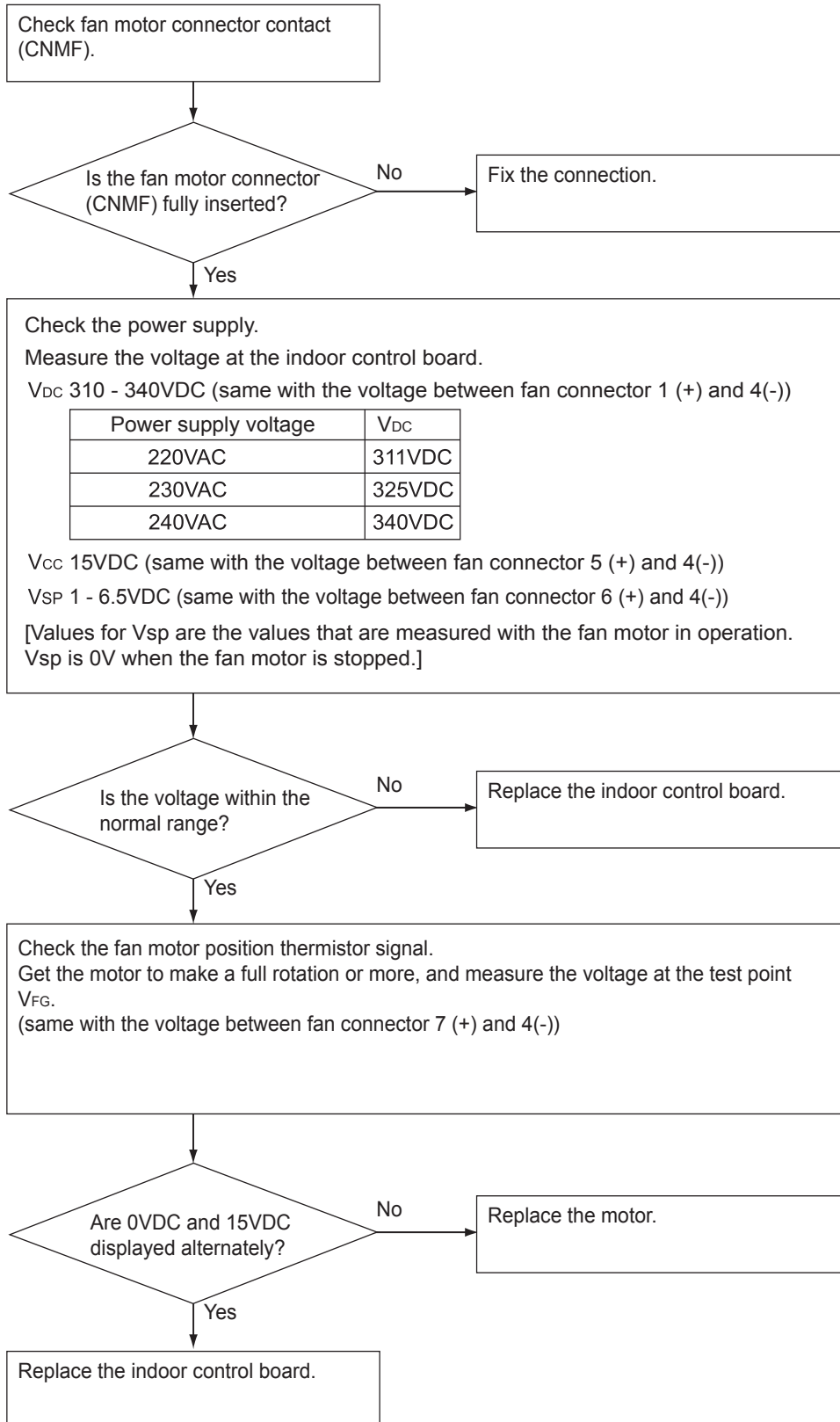

### 3. Address switch setting

Make sure that power to the unit is turned off.

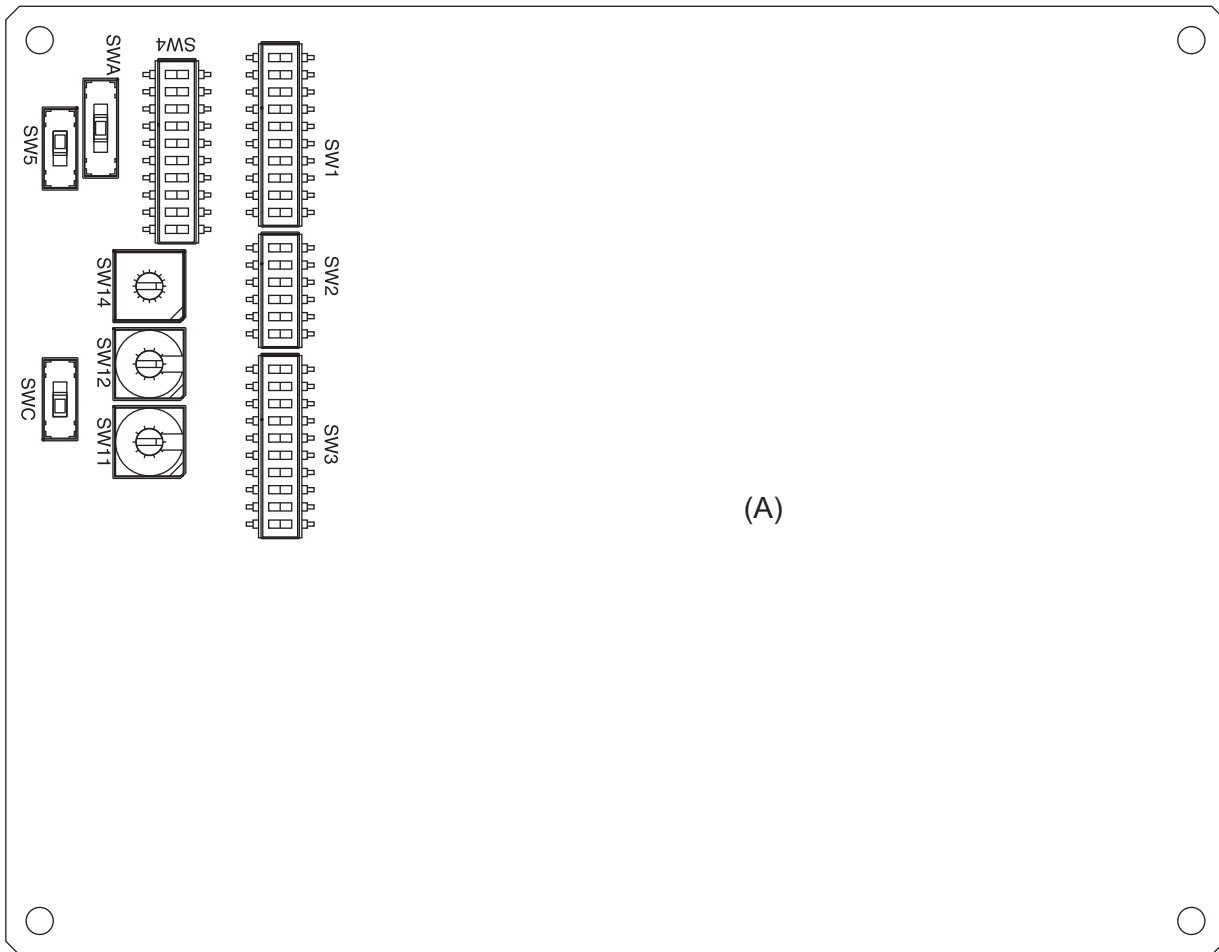

(A)

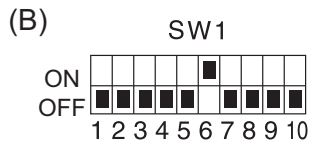

Please see the WIRING LABEL on the control box.

- (A) Indoor unit control board
- (B) Factory setting

1. When using an ME remote controller, set the address with the rotary switches (SW11, SW12).  
 •Address setting is not required when the unit remote controller is used.  
**On-site address setting is required for the indoor units to run.**
2. Address settings vary in different systems.  
 Refer to the section on address setting in the outdoor unit installation manual.
3. Address is set with a combination of SW12 (10's digit) and SW11 (1's digit).  
 To set the address to "3," set SW12 to "0" and SW11 to "3."  
 To set the address to "25," set SW 12 to "2" and SW 11 to "5."



### 4. Voltage test points on the control board

1. PEFY-P20, 25, 32, 40, 50, 63, 71, 80, 100, 125, 140VMA(L)-E

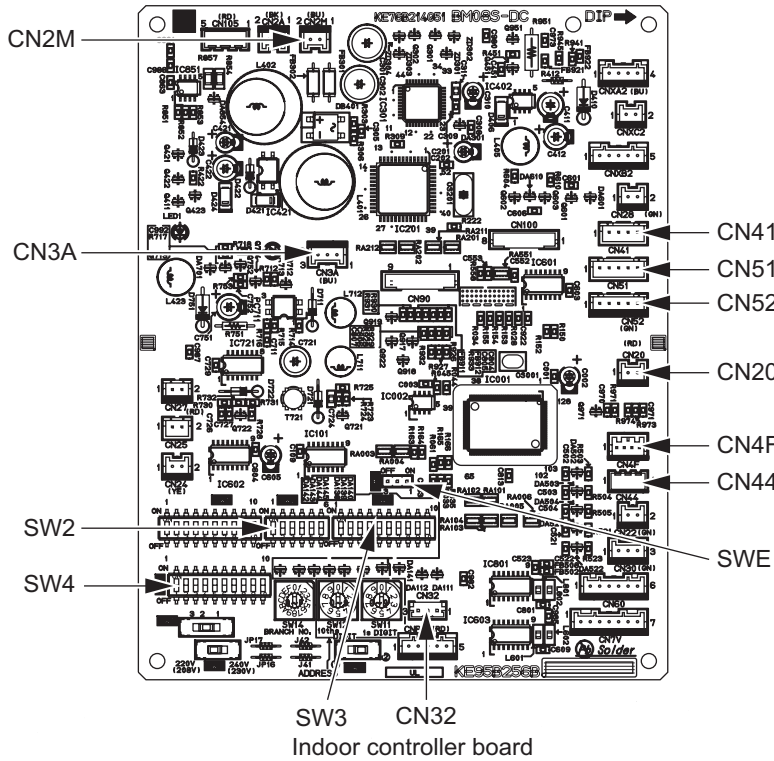

Indoor controller board

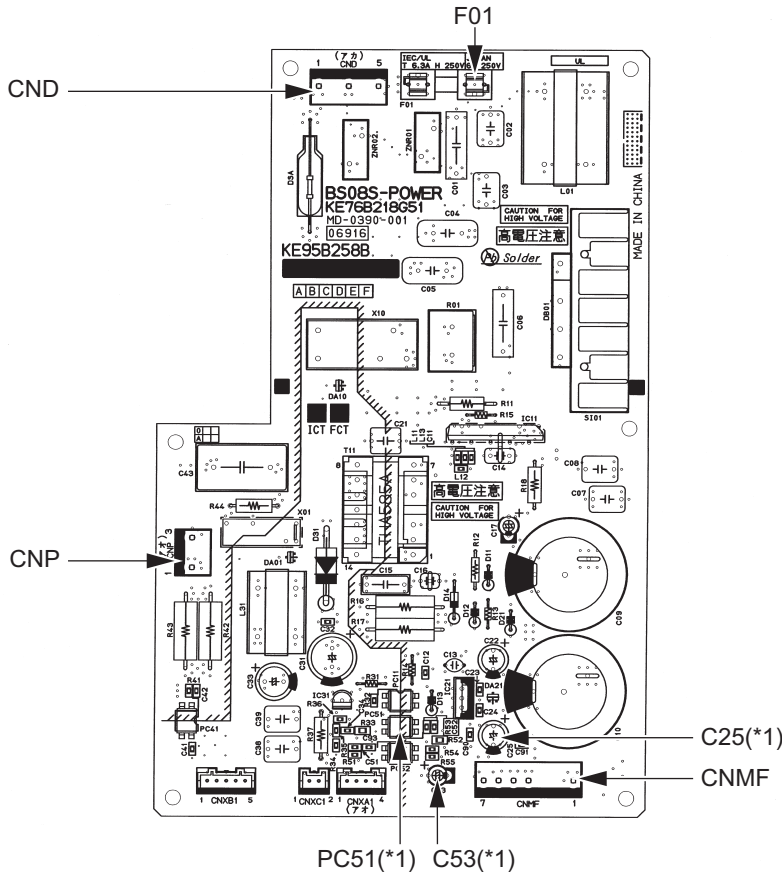

Power supply board

- F01 Fuse(AC 250V 6.3A)
- CND Power supply voltage (220 - 240VAC)
- CN2M For M-NET transmission cable connection (24 - 30VDC)
- SWE Emergency operation
- SW2 Capacity setting
- SW4 Function setting
- SW3 Function setting
- CN32 Remote start/stop adapter
- CN3A For MA remote controller cable connection (10 - 13 VDC (Between 1 and 3.))
- CN52 Remote display
- CN51 Centralized control
- CN41 JAMA standard HA terminal A
- CN44 Thermistor (liquid/gas temperature)
- CN4F Float thermistor
- CN20 Thermistor (Inlet temperature)
- CNMF Fan motor output  
 1 - 4: 310 - 340 VDC  
 5 - 4: 15 VDC  
 6 - 4: 0 - 6.5 VDC  
 7 - 4: Stop 0 or 15 VDC  
 Run 7.5 VDC  
 (0 - 15 pulse)
- CNP Drain-up mechanism output (200VAC)
- (\*1)  
 $V_{FG}$  Voltage on the (-) side of PC51 and C25  
 (Same with the voltage between 7 (+) and 4 (-) of CNMF)  
 $V_{CC}$  Voltage between the C25 pins  
 15 VDC  
 (Same with the voltage between 5 (+) and 4 (-) of CNMF)  
 $V_{sp}$  Voltage between the C53 pins  
 0VDC (with the fan stopped)  
 1 - 6.5VDC (with the fan in operation)  
 (Same with the voltage between 6 (+) and 4 (-) of CNMF)

### 5. Dipswitch setting (Factory setting)

1. Function setting

(1) SW1

Switch position	Function	Switch setting	
		ON	OFF
1	Active Thermistor (Intake air thermistor)	Built-in thermistor on the remote controller	Indoor unit
2	Filter clogging detection	Available	Unavailable
3	Filter life	2500 hr	100 hr
4	Outdoor air intake	Enabled	Disabled
5	Remote display	Thermo-ON signal	Fan output
6	Humidifier operation	During heating mode	During heating operation
7	Fan speed	Low	Very low
8	Fan speed at heating Thermo-OFF	Preset fan speed	Follows the setting of SW1-7
9	Auto restart after power failure	Enabled	Disabled
10	Power start/stop	Enabled	Disabled

1) Address board

Factory setting

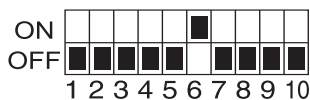

(2) SW3

Switch position	Function	Switch setting	
		ON	OFF
1	Unit type	Cooling only	Heat pump
2	-	-	-
3	-	-	-
4	-	-	-
5	-	-	-
6	-	-	-
7	-	-	-
8	Heating 4-deg up	Disabled	Enabled
9	-	-	-
10	-	-	-

1) Indoor control board

Dipswitch settings must be made while the unit is stopped.

Factory setting

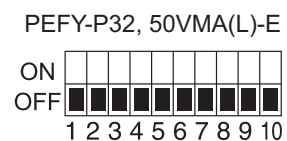
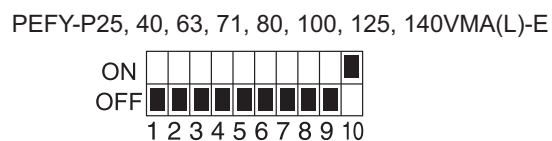

2. Capacity code setting

(1) SW2

1) Indoor control board

Dipswitch settings must be made while the unit is stopped.

Factory setting

The switches are set to correspond to the unit capacity.

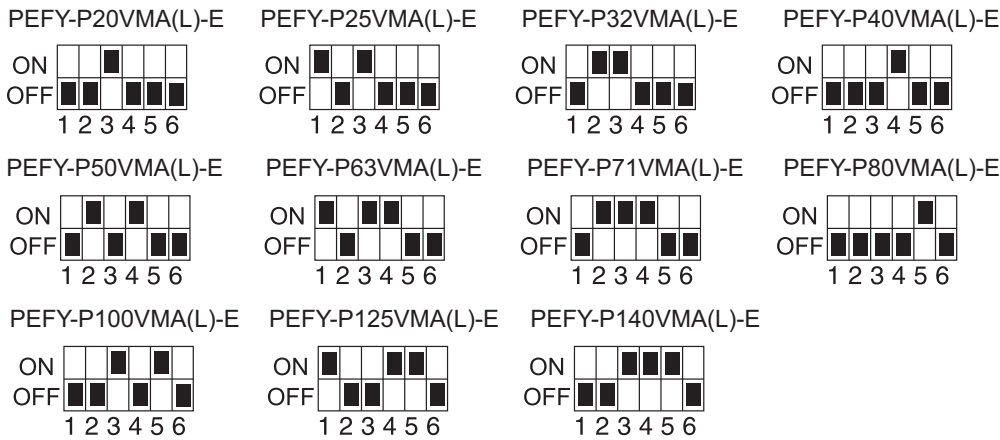

3. Model setting

(1) SW4

1) Indoor control board

Dipswitch settings must be made while the unit is stopped.

Factory setting

Please see the WIRING LABEL on the control box.

Note:

Changes made to the dipswitches SW1, SW2, and SW3 will become effective when the unit comes to a stop (remote controller off). There is no need to power cycle the unit.

4. Power voltage setting

(1) SW5

1) Indoor control board

Dipswitch settings must be operated with the main power turned OFF.

Factory setting

Please see the WIRING LABEL on the control box.

Set SW5 to 240V side when the power supply is 240 volts.  
When the power supply is 220 and 230 volts, set SW5 to 220V side.

5. External static pressure

(1) SWA, SWC

1) Indoor control board

All models

35Pa		50Pa		70Pa		100Pa		150Pa	
3	②	3	②	3	②	3	②	3	②
2		2		2		2		2	
1	①	1	①	1	①	1	①	1	①
SWA	SWC	SWA	SWC	SWA	SWC	SWA	SWC	SWA	SWC

Factory setting

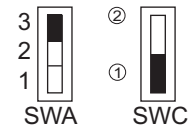

Note:

Changes that are made to the dipswitches SWA and SWC immediately become effective regardless of the unit's operation status (RUN/STOP) or the remote controller status (ON/OFF).

6. 1s and 10ths digits

(1) SW11, SW12 (Rotary switch)

The use of a network remote controller (PAR-F27MEA) requires address setting.

1) Indoor control board

Address settings must be made while the unit is stopped.

Factory setting

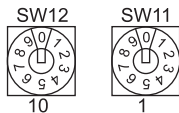

7. Connection No. setting

(1) SW14 (Rotary switch)

This switch is used when the unit connected to an R2 series of outdoor unit.

1) Indoor control board

Factory setting



Note:

Changes to the dipswitches SW11, SW12, SW14, and SW15 must be made while the unit is stopped and the remote controller is OFF.

---

## [1] Disassembly Procedure

---

### 1. Control box

**Exercise caution when removing heavy parts.**

1. Removing the control box cover
  - (1) Remove the three fixing screws on the cover (A) to remove it.

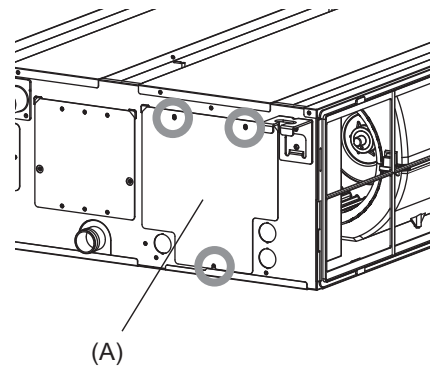

Fig.1

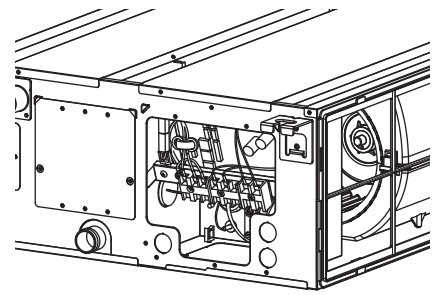

Fig.2

## 2. Thermistor (Intake air)

**Exercise caution when removing heavy parts.**

1. Remove the control box cover according to the procedure in section [1].
2. Remove the thermistor.
  - (1) Pull out the thermistor holder (B) and thermistor (C) on the control box.

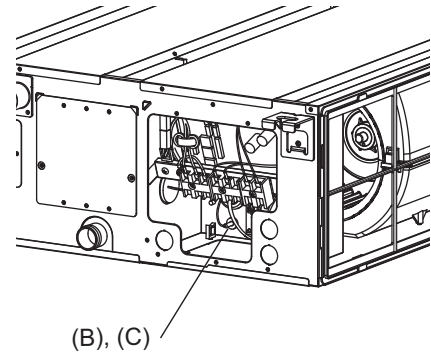

Fig.3

### 3. Drainpan

Exercise caution when removing heavy parts.

1. Removing the filter and the bottom plate

- (1) Push down the tab on the filter, and pull out the filter in the direction of the arrow 1.
- (2) Remove the fixing screws on the bottom plate (D), (E) to remove it.

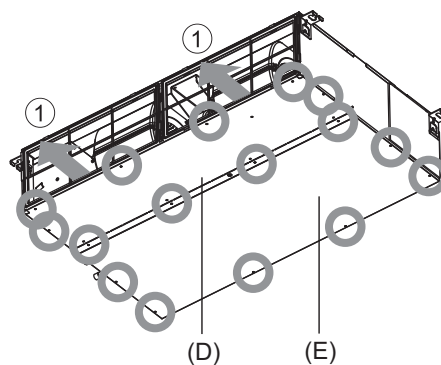

Fig.4

2. Removing the drainpan

- (1) Pull out the drain pan in the direction of the arrow 2.

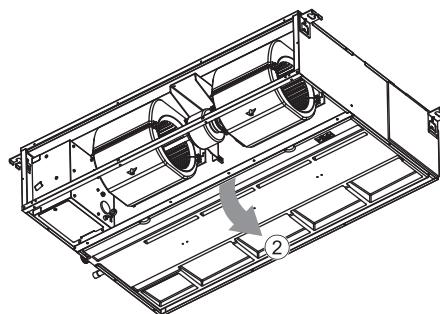

Fig.5

**Note**  
•Drain the water out of the drain pan before removing it.

#### 4. Thermistor (Gas pipe) (Liquid pipe)

Exercise caution when removing heavy parts.

1. Remove the drain pan according to the procedure in section [1].
2. Removing the Heat exchanger cover
  - (1) Remove the four fixing screws on the heat exchanger cover (F) to remove it.

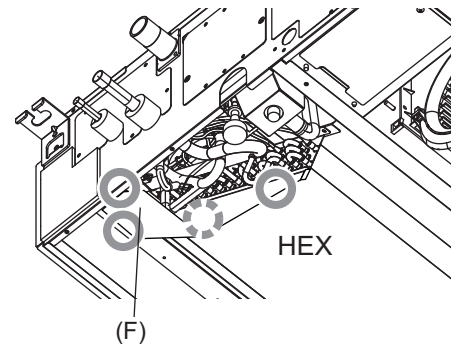

Fig.6

3. Removing the thermistor
  - (1) Remove the thermistor (G) from the thermistor holder (H) on the copper tube.

Thermistor size  
Liquid pipe:  $\varnothing 8\text{mm}$   
Gas pipe:  $\varnothing 6\text{mm}$

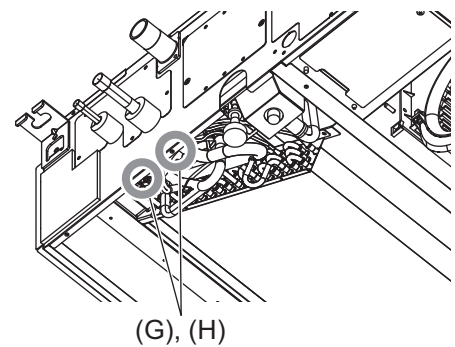

Fig.7



## 5. Fan and fan motor

Exercise caution when removing heavy parts.

### 1. Removing the filter and the bottom plate

- (1) Push down the tab on the filter, and pull out the filter in the direction of the arrow 1.
- (2) Remove the fixing screws on the bottom plate (J) to remove it.

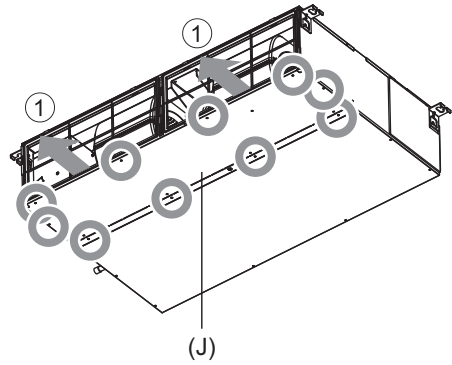

Fig.8

(a) Tab

### 2. Removing the fan casing (bottom half)

- (1) Squeeze the tabs on the fan casing to remove it in the direction of arrow 2.

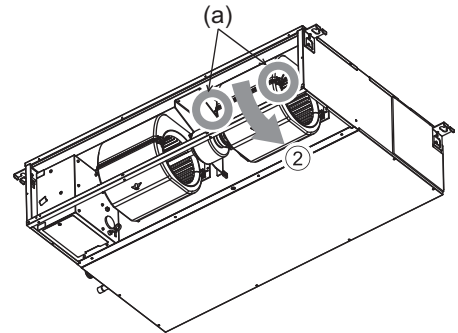

Fig.9

### 3. Removing the motor cable

- (1) Remove the motor cable through the rubber bush.

### 4. Removing the fan motor and the Sirocco fan

- (1) Remove the two motor fixing screws to remove the motor and the Sirocco fan in the direction of arrow 3.

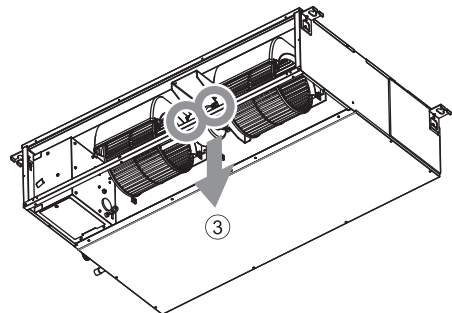

Fig.10

- (2) Remove the four fan case fixing screws to take the top half of the fan casing off.

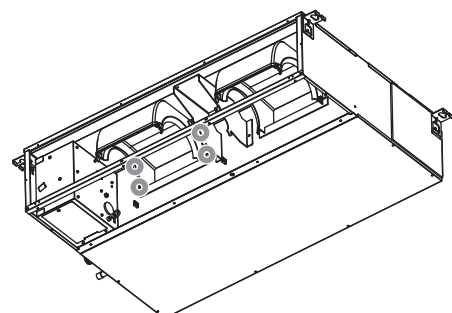

Fig.11

## 6. Heat exchanger

Exercise caution when removing heavy parts.

1. Remove the drain pan according to the procedure in section [1].
2. Remove the heat exchanger cover according to the procedure in section [4] 2.
3. Removing the cover
  - (1) Remove the five fixing screws on the cover (K) to remove it.

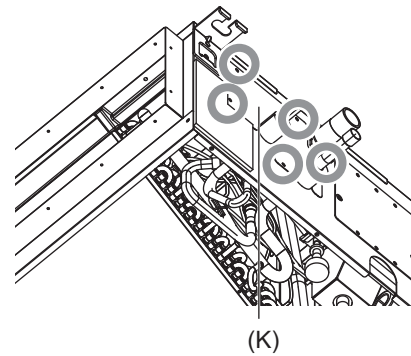

Fig.12

(K) Pipe support plate

4. Removing the Heat exchanger
  - (1) Remove the fixing screws on the heat exchanger (M) to remove it.

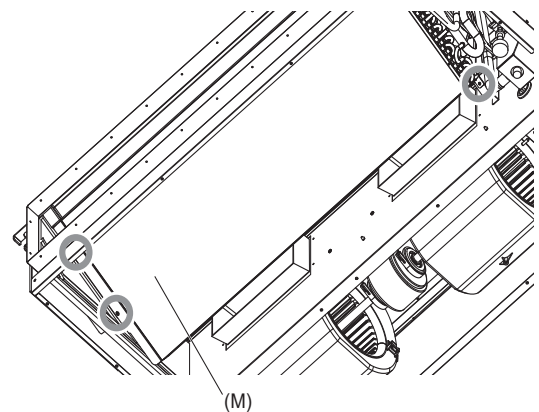

Fig.13



# **mitsubishi electric corporation**

<http://Global.MitsubishiElectric.com>

---