

# — Lossnay Control —

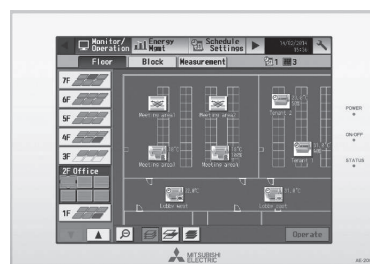

## 1. System Examples

Basic System (Refer to page C-10)	<p>One Lossnay with one remote controller</p> <ul style="list-style-type: none"> <li>● A simple system in which Lossnay is operated independently with one remote controller.</li> </ul>	<p>Multiple Lossnay units with one remote controller</p> <ul style="list-style-type: none"> <li>● Up to 15 Lossnay units can be controlled at one time with one remote controller.</li> </ul>	<p>Two remote controller system with one Lossnay</p> <ul style="list-style-type: none"> <li>● Lossnay can be controlled from two remote locations.</li> <li>● The remote controller gives priority to the last operation function request.</li> </ul>
-----------------------------------	--	---	---

Operation with an Air Conditioning Unit (Refer to page C-11)	<p>Operating with Mr. Slim (without Lossnay remote controller)</p> <ul style="list-style-type: none"> <li>● Use MA remote controller of Mr.Slim for switching Lossnay ON/OFF or the fan speed.</li> <li>● The ventilation mode is "automatic ventilation".</li> </ul>	Operating with an External Device (Refer to page C-12)	<p>Operating with Mr. Slim (with Lossnay remote controller)</p> <ul style="list-style-type: none"> <li>● Lossnay starts or stops according to Mr.Slim.</li> </ul>
--	---	--	---

<b>M-NET System</b>	<p>City Multi and Lossnay Interlocked System</p> <ul style="list-style-type: none"> <li>● One Lossnay can be interlocked with 16 indoor units. In addition, PZ-61DR-E can be connected for each Lossnay units.</li> </ul>
	<p>Centralized Management System</p> <ul style="list-style-type: none"> <li>● ON/OFF, fan speed and ventilation mode control is possible from the centralized controller.</li> <li>● Controller can set up the group including maximum of 15 indoor or Lossnay units.</li> </ul>

Two remote controller system with multiple Lossnay units

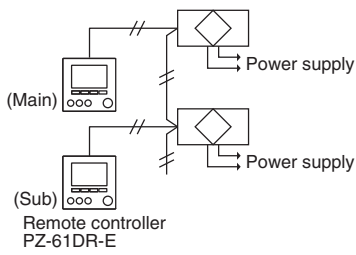

- It is also possible to operate two remote controller units when using multiple Lossnay units.

Operating with an external device

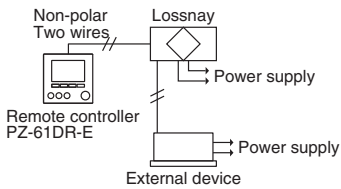

- Selection of interlocked operation mode is possible.
- Delayed start interlocked operation is possible.

- Lossnay starts or stops according to the external device.
- Level signal or pulse signal input (12VDC, 24VDC, and volt-free contact) is available.

Interlocking/individual combined systems

Interlock settings are possible with the inclusion of a group setting. (Joint use of the air conditioner remote controller and Lossnay remote controller is possible.)

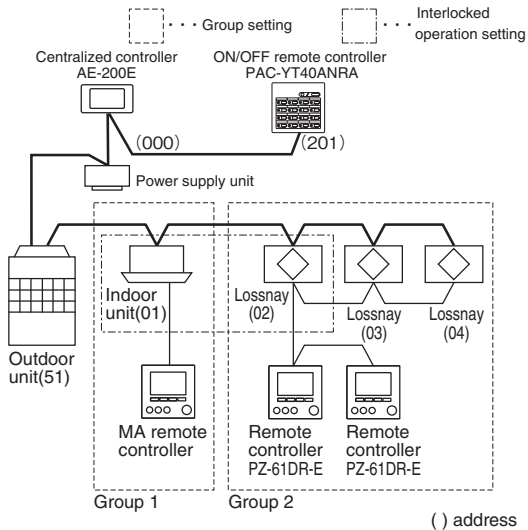

- Applicable indoor units are C type or later (for use with MA remote controller) models
- Set the different groups of indoor unit of air conditioner and Lossnay unit.

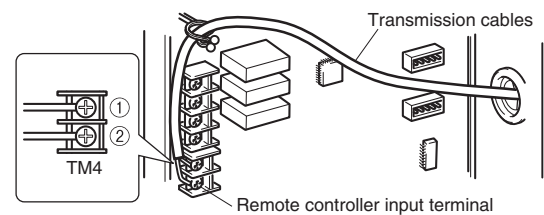
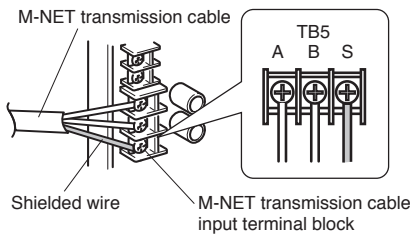
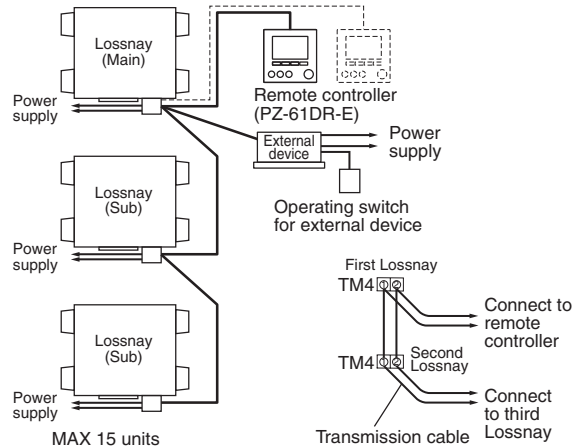
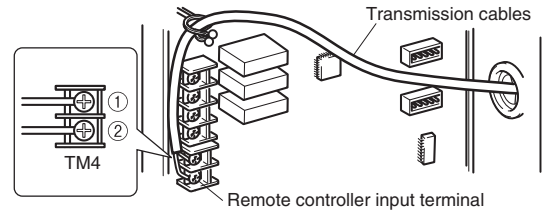

Address Setting

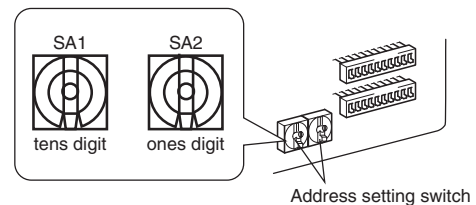

- When the address number has been changed, the data in the memory is automatically reset.

## 2. Function list and outline

### 2.1 Function list of LGH-RVX-E

No.	Item		LGH-RVX-E		Remarks	Page	
			PZ-61DR-E	PZ-43SMF-E			
1	Basic function	ON/OFF	○	○	Refer to RC manual	-	
		ON timer, OFF timer	○	○	Refer to RC manual	-	
		Weekly timer	○	×	8 pattern in a day	-	
		Fan speed switching (4 fan speeds)	○	×	PZ-61DR-E: all fan speed can be used and be skipped	-	
		Fan speed switching (2 fan speeds)	-	○	PZ-43SMF-E: 2 of 4 fan speed can be used	-	
		Ventilation mode selection (Energy recovery / Bypass / Automatic)	○	○		-	
		Night-purge	○	×		C-45	
		Night-purge from AG-150A/AE-200E	○	○	Not possible from PZ-43SMF-E	C-46	
		Max. fan speed operation during the first 30 minutes	○	×		C-38	
		Multi ventilation mode (Indoor negative / positive pressure)	○	○		C-37 C-38	
		Temperature display	○	×		C-33	
		Operation lock	○	×	Refer to RC manual	-	
		Function setting from remote controller	○	×		C-29	
2	Connectable remote controller	One LGH to one remote controller operation	○	○		C-10	
		Multiple LGHs to one remote controller operation	(Max 15 units)	(Max 15 units)		C-10	
		One or more LGHs to 2 remote controller operation	(Max 15 units)	(Max 15 units)		C-10	
3	Usage in M-NET systems	○	○		C-14		
4	Error code display	○	○		-		
5	Maintenance sign display	Filter	○	○		C-31	
		Lossnay core	○	×		C-31	
6	Operation by external device	External device or Type of input signal	City Multi	○	○		C-14
			Mr. Slim (without remote controller)	-	-	Use the cable attached with LGH product	C-11
			Mr. Slim (with remote controller)	△	△	PAC-SF40RM-E is necessary	C-12
			12/24VDC input	○	○		C-19
			Volt-free contact input	○	○		C-19
		Pulse input	○	○		C-20	
		Delay operation	LGH starts operation after air conditioner/external device turns ON	○ (15 or 30 min. later)	○ (30 min. later)		C-38
		Interlocked mode	ON/OFF interlock	Function is available either with or without remote controller		RC switching is available when interlocked	C-23
			ON interlock			Available only when becoming ON for not to forget to start operations	C-23
			OFF interlock			Available only when becoming OFF for not to forget to stop operation	C-23
External priority ON/OFF interlock	OFF from RC is not available during operation		C-23				
7	Switching fan speed by input signal			PAC-SA88HA-E is necessary	C-54		
	Switching ventilation mode by input signal			PAC-SA88HA-E is necessary	C-56		
8	Output signal	Operation monitor				C-52	
		Malfunction monitor				C-51	
		Bypass monitor or pre-heater				C-48 C-51	

○: Possible to use. △: Need accessory parts. ×: NOT available

## 2.2. Function list for Lossnay from local remote controller and system controller

The table below is a function table of controllers in the case that Lossnay is NOT interlocked with City Multi indoor unit.

When not interlocked with City Multi (Lossnay group)		Local remote controller		System controller			
		Lossnay remote controller		ON/OFF remote controller	Advanced touch controller	Centralized controller	Centralized controller
		PZ-61DR-E	PZ-43SMF-E	PAC-YT40ANRA	AT-50B	AG-150A	AE-200E
Maximum No. of controllable Groups/Units		1 / 15 *2	1 / 15 *2	16 / 50 *3	50 / 50 *3	50 / 50 *3	50 / 50 *3
Operation	ON/OFF	○	○	◎	◎	◎	◎
	Fan speed	4 fan speeds	2 of 4 fan speeds *6	×	2 of 4 fan speeds *6	3 of 4 fan speeds *7	3 of 4 fan speeds *7 4 fan speeds (ver.7.30 or later)
	Ventilation mode	○	○	×	○	○	○
	Local permit / prohibit	×	×	△ *4	◎	◎	◎
	Emergency stop *1	×	×	×	○	○	○
Status Monitoring	ON/OFF	○	○	○	○	○	○
	Fan speed	○	○	×	○	○	○
	Ventilation mode	○	○	×	○	○	○
	Temperature display	○	×	×	×	×	×
	Error indicator	○	○	○ *5	○	○	○
	Filter maintenance indicator	○	○	×	○	○	○
	Lossnay core maintenance indicator	○	×	×	×	×	×
	Local permit / prohibit	○	○	×	○	○	○
Scheduling/Recording	One-day	○	○	×	○	○	○
	Times of ON/OFF per day	1	1	×	16	24	24
	Weekly	○	×	×	○	○	○
	Times of ON/OFF per week	8 x 7	×	×	16 x 7	24 x 7	24 x 7
	Auto-off timer	○	○	×	×	×	×
	Minimum setting (minutes)	5	30	×	5	1	1
	Error record	○	×	×	○	○	○
Others	Operation restrictions (ON/OFF, Ventilation mode, fan speed)	○	×	×	△ *8	△ *8	△ *8
	Operation restrictions (Fan speed skip setting)	○	×	×	×	×	×
	Night-purge (given conditions)	×	×	×	×	△	△(-ver.7.11)
	Night-purge (free setting)	○	×	×	×	×	○(ver.7.20~)
	Bypass temp. free setting	○	×	×	×	×	×
	Heater-On temp. free setting	○	×	×	×	×	×
Fan power up after installation	○	×	×	×	×	×	

◎: Each group / Batched ○:Each group △: Available under some conditions ×: NOT available

\*1: Only available for bulk operation.

\*2: Maximum number of controllable units may change according to system configuration of the group.

\*3: Up to 16 units in a group can be operated with one system controller

\*4: By using an external volt-free contact signal it is possible to send ON/OFF or Prohibit/Permit local remote controller operation commands to all units being controlled.

\*5: LED flashes during failure.

\*6: High fan speed of remote controller is fan speed 3 or 4 of Lossnay unit. Lo is 1 or 2.

\*7: High fan speed of remote controller is fan speed 3 or 4 of Lossnay unit. Middle is 2. Lo is 1.

\*8: It is possible to lock the touch screen operation.

## 2.3. Function list for Lossnay interlocked with indoor unit from local remote controller and system controller

The table below is a function table of controllers in the case that Lossnay is interlocked with City Multi indoor unit.

When interlocked with City Multi		Local remote controller			System controller			
		MA remote controller	Smart ME Controller	Simple MA remote controller	ON/OFF remote controller	Advanced touch controller	Centralized controller	Centralized controller
		PAR-31MAA	PAR-U02MEDA	PAC-YT52CRA	PAC-YT40ANRA	AT-50B	AG-150A	AE-200E (Later ver7.20)
Operation	ON/OFF *1	○	○	○	◎	◎	◎	◎
	Fan speed	2 of 4 fan speeds *2	2 of 4 fan speeds *2	N	N	2 of 4 fan speeds *2	2 of 4 fan speeds *2	2 of 4 fan speeds *2
	Ventilation mode	x	x	x	x	x	x	x
	Local permit / prohibit	x	x	x	x	x	x	x
	Emergency stop	x	x	x	x	○	◎	◎
Status Monitoring	ON/OFF	○	○	○	○	○	◎	◎
	Fan speed	○	○	x	x	○	○	○
	Ventilation mode	x	x	x	x	x	x	x
	Temperature display	x	x	x	x	x	x	x
	Error indicator	○	○	○	○*3	◎	◎	◎
	Filter maintenance indicator	○	○	x	x	○	○	○
	Lossnay core maintenance indicator	x	x	x	x	x	x	x
	Local permit / prohibit	x	x	x	x	x	x	x
Scheduling/ Recording	One-day *1	○	○	x	x	○	○	○
	Times of ON/OFF per day	1	1	x	x	16	24	24
	Weekly *1	○	○	x	x	○	○	○
	Times of ON/OFF per week	8 x 7	8 x 7	x	x	16 x 7	24 x 7	24 x 7
	Auto-off timer *1	○	○	x	x	x	x	x
	Minimum setting (minutes)	5	5	x	x	5	1	1
	Error history	○	x	x	x	○	○	○
Others	Operation restrictions (ON/OFF, Ventilation mode, fan speed)	x	x	x	x	x	x	x
	Operation restrictions (Fan speed skip setting)	x	x	x	x	x	x	x
	Night-purge (given conditions)	x	x	x	x	x	x	x
	Night-purge (free setting)	x	x	x	x	x	x	x
	Bypass temp. free setting	x	x	x	x	x	x	x
	Heater-On temp. free setting	x	x	x	x	x	x	x
	Fan power up after installation	x	x	x	x	x	x	x

◎: Each group / Batched ○:Each group △: Available under some conditions x: NOT available

\*1: When City Multi indoor unit is ON, Lossnay is ON.

\*2: High fan speed of remote controller is fan speed 3 or 4 of Lossnay unit. Lo is 1 or 2.

\*3: LED flashes during failure.

## 3. System structure

### 3.1 Notes/Cautions when system configuration

#### 3.1.1 Basic system Operation by local remote controller (Refer to page C-10)

Following local remote controllers can be used.

- Lossnay Remote Controller PZ-61DR-E
- Lossnay Remote Controller PZ-43SMF-E

- (1) Different model remote controllers cannot be used together in a group.
- (2) Maximum 2 remote controllers can be connected in a group.
- (3) When two PZ-61DR-E are used in a group, set one remote controller as main and the other as sub.  
(Refer to installation manual of PZ-61DR-E.)
- (4) Adequate remote controller cable
  - Securely connect the transmission cable from the remote controller to the terminal block (TM4①②). (No polarity)
  - Keep the overall length of the transmission cable between Lossnay and the remote controller within 200 m.
  - Maximum torque:0.5N·m.

Wire type	2 core sheathed cable
Wire diameter	0.3mm <sup>2</sup>
Max overall length between Lossnay and remote controller	200m

#### 3.1.2 Group setting

Lossnay units set in a group can be operated at the same time from local remote controller.

- (1) It is not possible to set Lossnay and Indoor unit of air conditioner in a group.
- (2) When using local remote controller or interlocking with external device,
  - Lossnay units connected via the terminal block (TM4①②) each other become the same group.
  - The maximum number of Lossnay units in one group is 15.
  - When connected to MELANS\*, perform group setting from system controller so that each Lossnay unit connected via the terminal block (TM4①②) becomes the same group.
- (3) When connected to MELANS\*, without Lossnay remote controller and not interlocked with City Multi indoor units or any external device.
  - Set the groups by the System controller.
  - The maximum number of Lossnay units in one group is 16.
  - Connection via the terminal block (TM4①②) is not necessary.

However, in order to perform Night-purge function by using the system controller (AE-200E), connect them to each other.

\*MELANS : MITSUBISHI ELECTRIC's Air-conditioner Network System

#### 3.1.3 Interlocking with City Multi(Refer to page C-14)

When Lossnay and City Multi are connected to MELANS, it is possible to switch Lossnay "ON/OFF" and "High/Low" operation from the indoor unit remote controller.

Ventilation mode is fixed to Automatic mode.

- (1) One Lossnay unit can be interlocked with up to 16 indoor units.
- (2) Perform interlock settings at the system controller or local remote controller of City Multi indoor unit.
- (3) The Lossnay remote controller (PZ-61DR-E, PZ-43SMF-E) can be used.
- (4) It is not possible to be interlocked together with Mr. Slim or external device.
- (5) When interlocking City Multi indoor unit and Lossnay,
  - Perform interlock wiring from the main indoor unit (smallest address number unit) in the group.
  - Connect the terminal block (TM4①②) of each Lossnay unit.
- (6) Following interlock mode are NOT available.(Refer to page C-23)
  - ON interlock (DIP-SW5-7 ON, DIP-SW5-8 OFF)
  - OFF interlock (DIP-SW5-7 OFF, DIP-SW5-8 ON)

**3.1.4 Interlocking with Mr. Slim (Refer to page C-11)**

When Lossnay is connected to Mr. Slim with Slim-Lossnay connection cable (enclosed accessory parts with Lossnay unit), it is possible to switch Lossnay “ON/OFF ” and “High/Low” operation from the indoor unit remote controller.

Ventilation mode is fixed to Automatic mode.

- (1) One Lossnay can be interlocked with an indoor unit of air conditioner, but cannot be interlocked with multiple indoor units .
- (2) The Lossnay remote controller (PZ-61DR-E, PZ-43SMF-E) cannot be used on systems interlocked with Mr. Slim.
- (3) Use malfunction monitor output (TM3⑧⑩) to notice Lossnay error.
- (4) It is not possible to be interlocked together with City Multi or external device.
- (5) It is not possible to stop Lossnay unit during Mr. Slim operation.

**3.1.5 Interlocking with indoor unit of air conditioner or other external device including other manufacturers (Refer to page C-11, C-19)**

It is possible to control Lossnay unit ON/OFF by the signal to the terminal block TM2 from the external device interlocked with Lossnay.

- (1) When volt-free contact is used. (Refer to page C-19)
  - Securely connect signal cable to the input terminal block (TM2 ① ③).
  - The units start operation when contact is closed.
  - More than 10 sec. is necessary to turn Lossnay ON and OFF.
  - The total length of transmission cables should be no longer than 500 m.
  - When using relay contact, contact rating must be more than 15 VDC/0.1 A, and minimum application load must be less than 1 mA.
  - If an photocoupler or any other type of polar coupler is used at the volt-free contact, connect the live side to TM2 ③ and the neutral side to TM2 ①.
- (2) When 12VDC/24VDC level input is used. (Refer to page C-19)
  - Securely connect signal cable to the input terminal block (TM2 ① ②). (No polarity)
  - The unit starts operation when 12VDC or 24VDC input is received.
  - More than 10 sec. is necessary to turn Lossnay ON and OFF.
  - Follow the operation manual for the external equipment about overall connection extension length of signal cable.
  - Use external device which has input voltage 12VDC or 24VDC and output current more than 0.1A.
- (3) When pulse input is used. (Refer to page C-20)
  - Turn the [DIP-SW2-2] to ON. When using PZ-61DR-E, it can be set also from the remote controller.
  - ON/OFF is inverted each time the pulse signal is input.
  - A pulse width of at least 200 msec is needed to turn Lossnay ON or OFF, and 10 sec. absence is necessary to next input.
  - External device priority interlock mode and delay operation are not available.
  - Both volt-free contact and 12VDC/24VDC input are available.

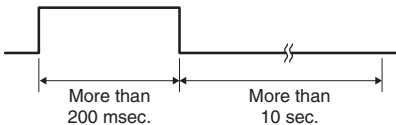

- (4) Controlling a Lossnay group from the external device.
  - Be sure to input the signal to main unit in the group. Refer to page C-9
  - Connect the terminal block (TM4①②) of each Lossnay unit.
- (5) Use signal cable 0.5mm<sup>2</sup> to 1.5mm<sup>2</sup> wire diameter.
- (6) Local remote controller can be used.
- (7) When not connected to MELANS and not using local remote controller, use monitor output (TM3⑧⑩) to notice Lossnay error.
- (8) Cannot be interlocked together with City Multi or Mr. Slim.

**3.1.6 Connecting to MITSUBISHI ELECTRIC's Air-conditioner Network System (MELANS)**

Lossnay can be used with MELANS. Multiple Lossnay units and groups can be operated by centralized controller.

- (1) Perform group setting from system controller. Refer to “System controller manual”
- (2) The Lossnay unit which has smallest address in a group is the main unit. Set the address number of each Lossnay sub unit in the sequential number from the main unit address number.
- (3) Local remote controller can be used.
- (4) When interlocking with Mr. Slim, install M-NET connection adapter (PAC -SF83MA-E etc.) to outdoor unit in order to connect Mr. Slim to MELANS.
- (5) Securely connect the M-NET transmission cables to TB5 [A],[B] (No-Polar).  
Adequate transmission cable

Wire type	2 core shielded wire CVVS / CPEVS
Wire diameter	1.25mm <sup>2</sup> to 2.0mm <sup>2</sup>
Max total length	500m
Max length between Lossnay and power supply unit or outdoor unit	200m



### 3.1.7 Main unit setting

When multiple Lossnay units are in one group, main unit setting is needed depending on system configuration or intended end-usage. Main unit exist only one in a group, and it communicates with MELANS, City Multi and external devices. There are two ways to set main unit, (1) Address setting and (2) DIP-SW setting. If both (1) and (2) are needed, make sure to set the same Lossnay as main unit by both setting.

Check the necessary settings in following chart.

System configuration / Intended end-usage	Main unit settings of multiple Lossnay units
When Lossnay unit make an error, its address number will be displayed on Lossnay remote controller *1 Connection to M-NET	“(1) Address setting” is necessary. Make any unit as main unit.
Interlocking with indoor unit of non-Mitsubishi air conditioner or other external device *1 Use the remote/local switching and the ON/OFF input (CN32) *1	“(2) DIP-SW setting” is necessary. Set the Lossnay unit connected signal input as main unit.
Make the same operation to the Lossnay units in the group by the following signal input *1*2*3 • Fan speed switching externally by volt-free contact (CN17) • Fan speed switching externally by 0-10VDC input (CN26) • Bypass switching externally by volt-free contact (CN26)	
None of the above	Main unit setting is not necessary.

\*1 Connect the terminal block (TM4①②) of each Lossnay unit in the group. Refer to page C-3

\*2 PZ-61DR-E is necessary.

\*3 When performing a signal input to each Lossnay unit in the group, (2)DIP-SW setting is not necessary.

**<Caution>**

- When there is only one Lossnay unit, main unit setting is not necessary.
- Be sure to set only one unit as main in a group.
- If there is no external input signal, main unit setting is not necessary even if the group includes multiple Lossnay units.
- When using in M-NET (with address setting), Lossnay unit which has the smallest address number is recognized as main unit. In this case, main unit setting is not necessary.

(1) Address setting

Address is identification number set to each unit of Lossnay, indoor unit, outdoor unit, ME remote controller and system controller in MELANS. Set address number not to overlap in a system (connected with M-NET transmission cable).

- Main unit  
Set main unit address number within the range of “01” to “50” .  
Be sure to set any address number in MELANS not to overlap.
- Sub unit (Except main unit)  
Address number is set in the sequential number from the main unit address number (see the example on the right). Be sure to set in MELANS not to overlap address number.

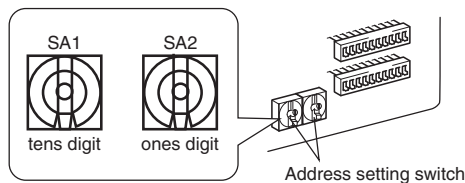
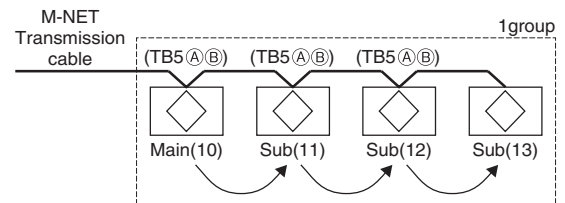

(2) DIP-SW setting

DIP-SW		Main / Sub
SW No.	Setting	
SW5-10	OFF (Factory setting)	Sub unit
	ON	Main unit

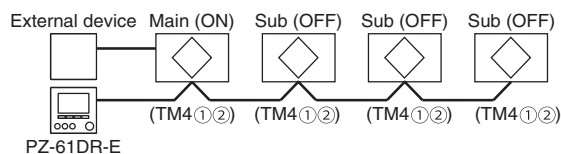

Connect the input terminal block (TM4①②) of each Lossnay units.

## 3.2 Basic System

### 3.2.1 Connecting with remote controller

Securely connect the transmission cable from the remote controller to the terminal block (TM4 ①②).

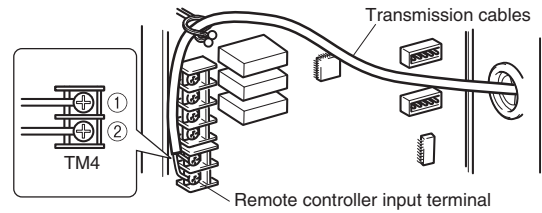

#### (1) Connecting with PZ-61DR-E

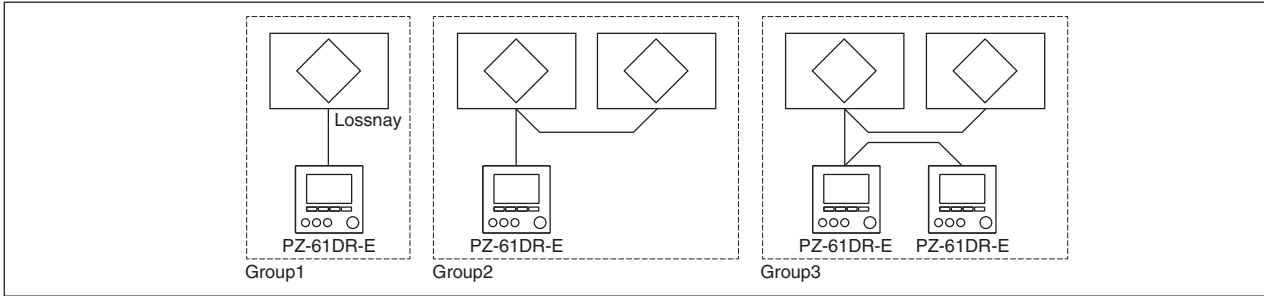

Group	Feature
Group1	One Lossnay unit and one Lossnay remote controller.
Group2	Multiple Lossnay units and one Lossnay remote controller. <ul style="list-style-type: none"> <li>• Up to 15 Lossnay units can be controlled in a group.</li> <li>• The main unit setting on the Lossnay is not necessary.</li> </ul>
Group3	Multiple Lossnay units and two Lossnay remote controllers. <ul style="list-style-type: none"> <li>• Up to 15 Lossnay units can be connected in a group.</li> <li>• Maximum 2 remote controllers can be used.</li> <li>• 2 of the remote controllers must be the same model.</li> <li>• Set one remote controller as the main and the other as the sub.</li> <li>• The remote controller gives priority to the last touch.</li> <li>• The main unit setting on the Lossnay is not necessary.</li> </ul>

#### (2) Connecting with PZ-43SMF-E

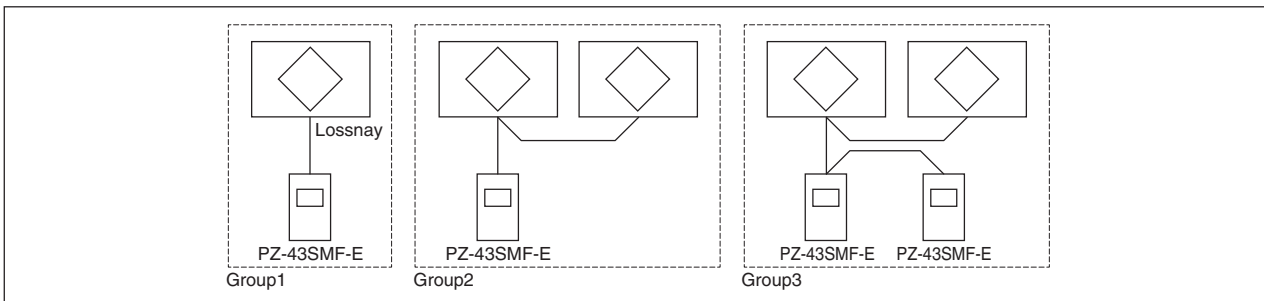

Group	Feature
Group1	One Lossnay unit and one Lossnay remote controller.
Group2	Multiple Lossnay units and one Lossnay remote controller. <ul style="list-style-type: none"> <li>• Up to 15 Lossnay units can be controlled in a group.</li> <li>• The main unit setting on the Lossnay is not necessary.</li> </ul>
Group3	Multiple Lossnay units and two Lossnay remote controllers. <ul style="list-style-type: none"> <li>• Up to 15 Lossnay units can be connected in a group.</li> <li>• Maximum 2 remote controllers can be used.</li> <li>• 2 of the remote controllers must be the same model.</li> <li>• The remote controller gives priority to the last touch.</li> <li>• The main unit setting on the Lossnay is not necessary.</li> </ul>

#### <CAUTION>

- When it is interlocked with an external device (TM2, CN17, CN26, CN32), turn ON the setting switch (DIP-SW5-10) of the main Lossnay to which the external signal is input.
- See 3.1.1 (page C-7) for the other cautions.

## 3.3 Interlocking with Mr. Slim

### 3.3.1 Connecting with Slim-Lossnay connection cable

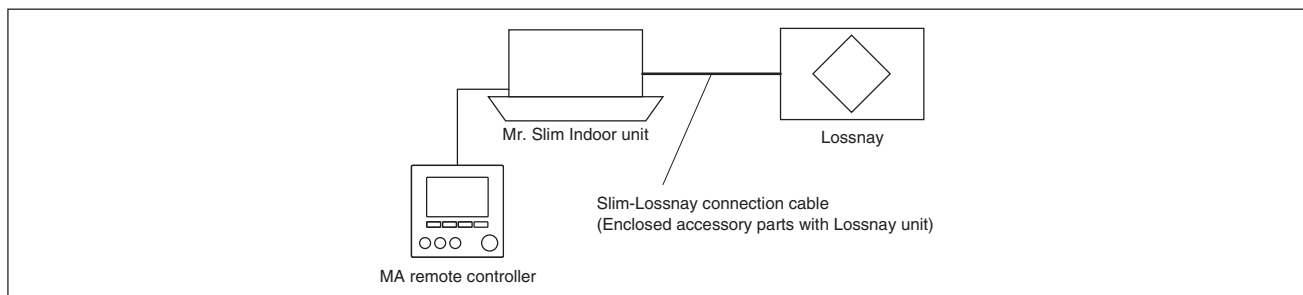

#### <Feature>

- It is possible to control both of Mr. Slim and Lossnay unit with MA remote controller.
- It is possible to use MA remote controller of the Mr. Slim for switching Lossnay ON/OFF or the fan speed.
- If Lossnay supply duct is connected to Mr. Slim indoor unit, supply fan of Lossnay unit will stop during defrosting of the indoor unit.

#### <Caution>

- The Lossnay remote controller (PZ-61DR-E) cannot be used with this system.
- The ventilation mode is fixed to “automatic mode”.
- When indoor unit is operating, it is not possible to stop the Lossnay unit independently.
- It is not possible to interlock with multiple Mr. Slim indoor units.
- It is necessary to take malfunction monitor output by connection to TM3⑧⑩. (Refer to page C-51)
- See 3.1.4 (page C-8) for the other cautions.

#### < Wiring >

- Connect CN2L on the PCB of Mr. Slim indoor unit to TM2①② of Lossnay PCB.
- The Slim-Lossnay connection cable is 100 mm long. Extend it to fit the configuration. (Maximum 500m)  
Ensure that all connections are secure and that the appropriate insulation is provided.  
Use extension cable sheathed PVC cable or cable 0.5 mm<sup>2</sup> to 0.75 mm<sup>2</sup>.  
Always separate the power supply cable and the Slim-Lossnay connection cable by 5 cm or more to prevent the unit from malfunction.

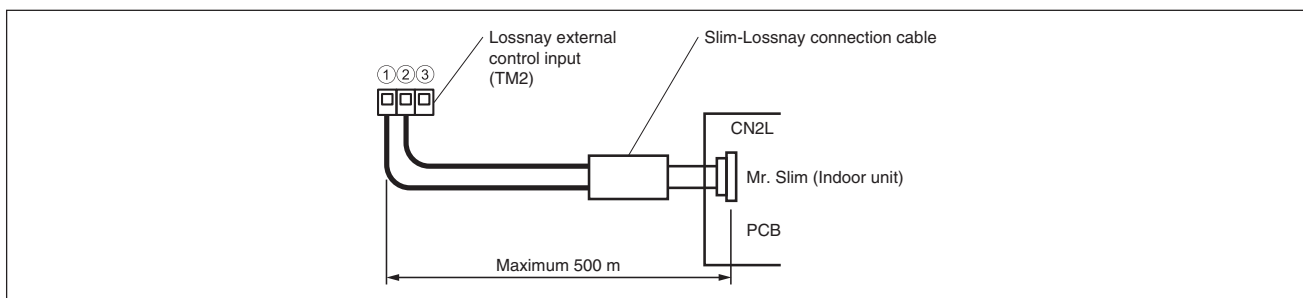

#### <Operation>

##### (1) Interlocking operation

- Lossnay unit turns ON at the same time when Mr. Slim starts operation.
- Switching High/Low fan speed is possible.  
“High” is fan speed 4 and “Low” is fan speed 2 at the factory setting. They can be changed. (Refer to page C-40)

##### (2) Individual operation

[When using MA remote controller PAR-31MAA]

- Select “Vane, Louver, Vent.(Lossnay)” from the main menu, and press the **SELECT** button.
- Press **F3** button to go through ventilation setting options in order of “High,” “Low” and “Off”.

**3.3.2 Connecting with a-control remote operation adapter PAC-SF40RM-E**

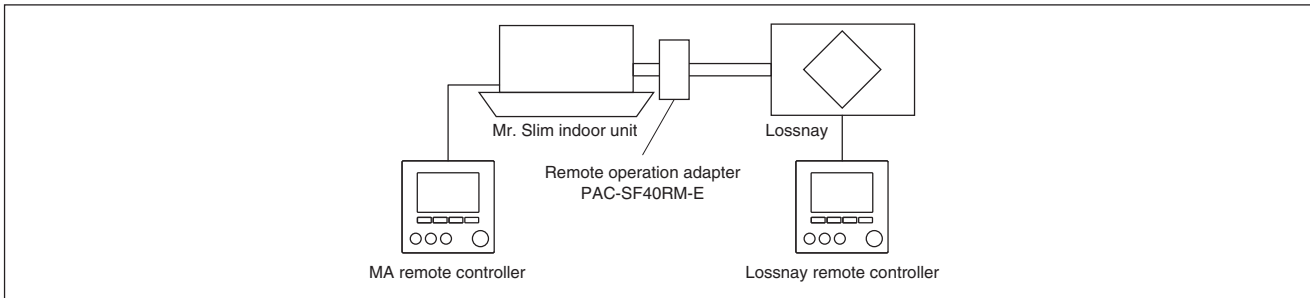

**<Feature>**

- Lossnay operation can be interlocked with Mr. Slim operation.
- Lossnay can be interlocked with multiple Mr. Slim units.
- This system is similar control to level signal input of volt-free contact. Refer to page C-19

**<Caution>**

- Ventilation fan speed selection button cannot be used on MA remote controller (Air conditioner remote controller).
- Lossnay cannot operate independently from MA remote controller (Air conditioner remote controller). (Possible from Lossnay remote controller.)
- If Lossnay unit operates during Mr. Slim stop operation, in the case that Lossnay supply air duct is connected to Mr. Slim indoor unit (outside air intake), Lossnay unit cannot supply the air into the room properly because the fan of Mr. Slim does not work.
- Cannot switch ventilation mode automatically in accordance with the operation mode of Mr. Slim.

**<Wiring>**

- Connect remote operation adapter connector side to CN41, CN90 on the PCB of the Mr. Slim indoor unit, then connect the lead wire side to the TM2①③ of Lossnay PCB. (No polarity)
- Keep the overall length of the transmission cable between Lossnay and the remote operation adapter within 100 m. Use transmission cable 0.5 mm<sup>2</sup> to 1.25 mm<sup>2</sup> sheathed PVC cable. Always separate the power supply cable and the signal cable by 5 cm or more to prevent the unit from malfunction.

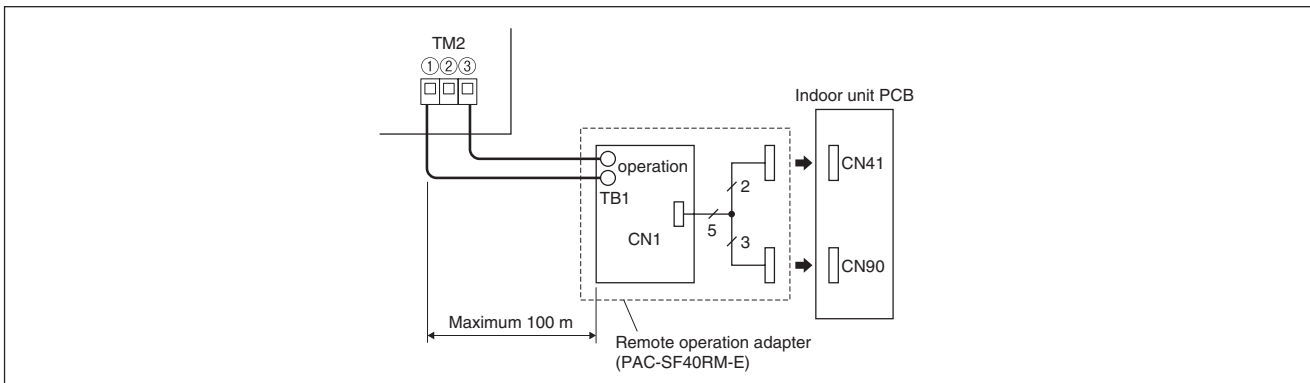

**<Operation>**

- Lossnay unit turns ON at the same time when Mr. Slim starts operation.
- The fan speed is fixed to “fan speed 4” and ventilation mode is fixed to “automatic mode. However, if there is a remote controller (PZ-61DR-E or PZ-43SMF-E), the unit will follow the settings from the remote controller.

### 3.3.3 Connecting with M-NET connection adapter PAC-SF83MA-E

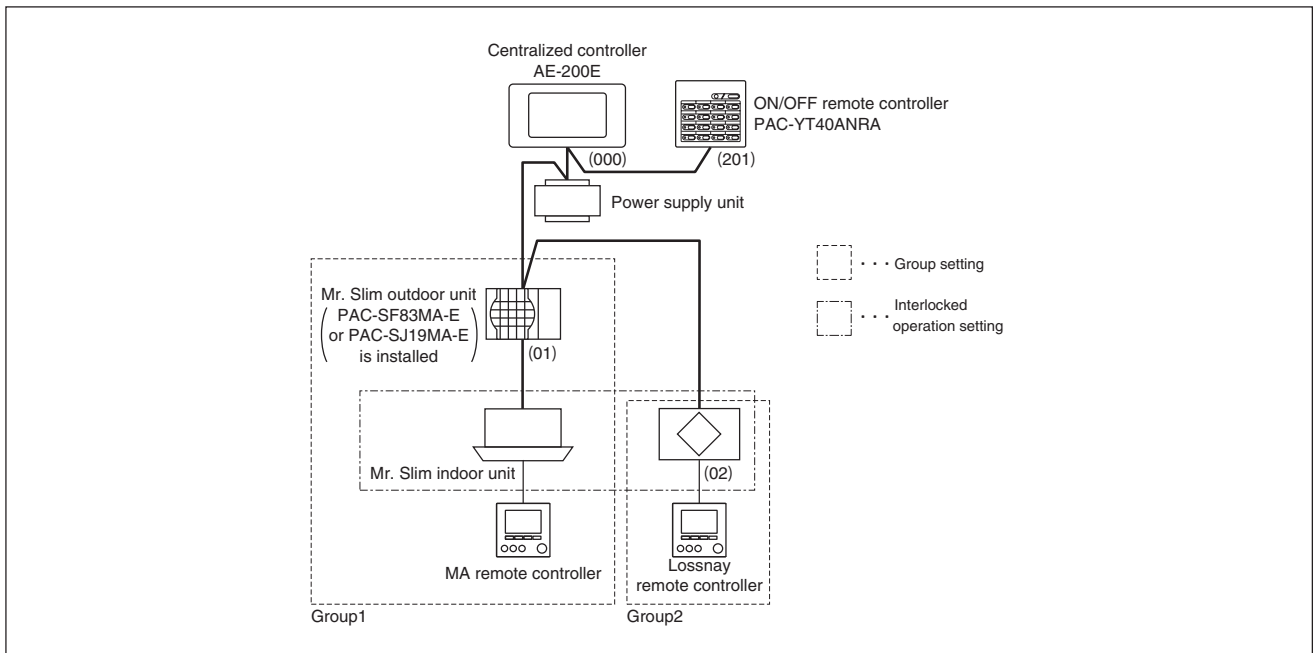

#### <Feature>

- Lossnay can be turned ON/OFF with Mr. Slim operation.
- Lossnay can be interlocked with multiple Mr. Slim units.
- Possible to use with MELANS as same as page C-14

#### <Caution>

- If Lossnay unit operates when Mr. Slim is OFF, in the case when Lossnay supply air duct is connected to Mr. Slim indoor unit (outside air intake), Lossnay unit cannot supply the air into the room properly because the fan of Mr. Slim does not work.
- When not using ON/OFF remote controller PAC-YT40ANRA, the power supply unit is not necessary.

#### <Wiring>

- Connect M-NET transmission cable to TB5 [A], [B] on Lossnay PCB.

#### <Operation>

##### (1) Interlock operation

- Lossnay unit turns ON at the same time when Mr. Slim starts operation.
- Switching High/Low fan speed is possible.  
“High” is fan speed 4 and “Low” is fan speed 2 at the factory setting. (Refer to page C-40)

##### (2) Individual operation

[When using MA remote controller PAR-31MAA]

- Select “Vane, Louver, Vent.(Lossnay)” from the main menu, and press the **[SELECT]** button.
- Press **[F3]** button to go through ventilation setting options in order of “High”, “Low” and “Off”.  
It is possible to set the fan speed when receiving “High/Low” signal. (Refer to page C-40)

### 3.4 M-NET system

#### 3.4.1 Wiring

- Securely connect the M-NET transmission cables to TB5 [A] [B] and shielded wire to TB5 (S).  
 Type: Shielded wire (CVVS/CPEVS)  
 Wire diameter: 1.25 mm<sup>2</sup> to 2.0 mm<sup>2</sup>  
 Maximum torque: 0.5 N·m

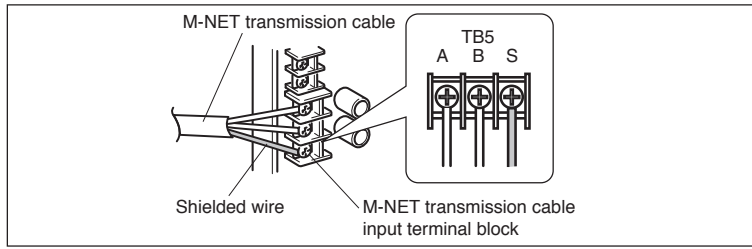

#### 3.4.2 Address setting

Address setting is required when connecting to City Multi and MELANS. Refer to page C-9

#### 3.4.3 Lossnay system

<Feature>

- The MELANS can operate and monitor each group of Lossnay units.
- The Lossnay remote controller can also be used to operate.

<Caution>

- All of Lossnay units require an address.
- When not using ON/OFF remote controller PAC-YT40ANRA, the power supply unit is not necessary.

<System example 1>

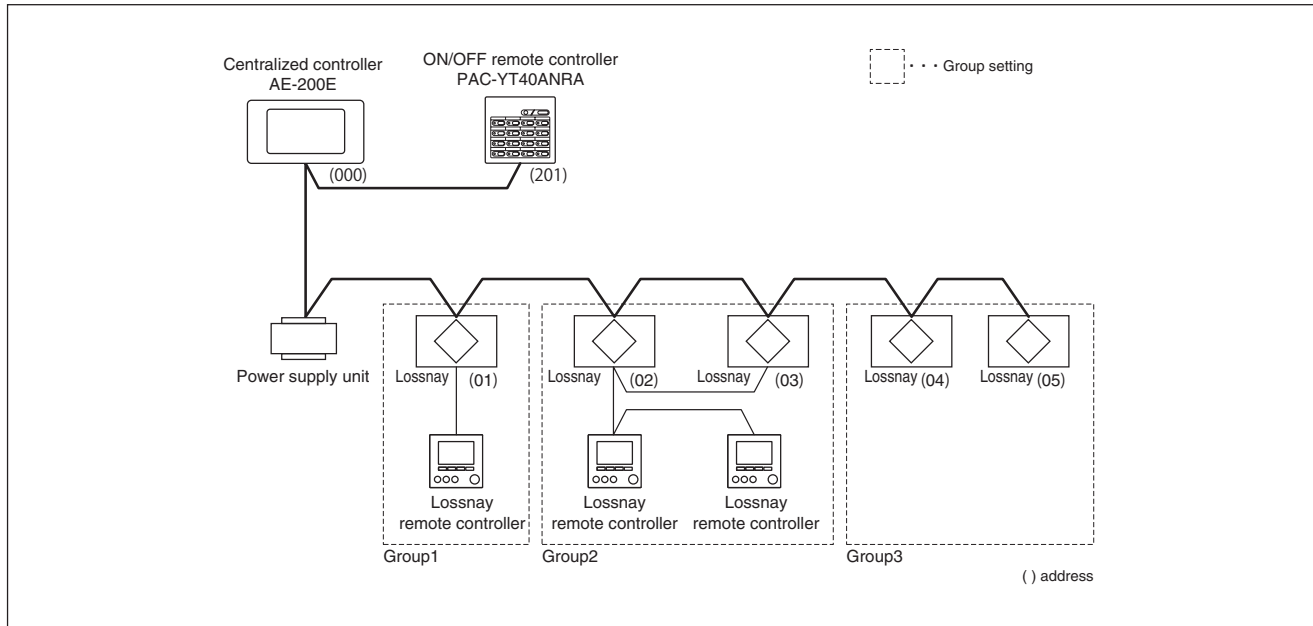

Group	Feature
Group1	One Lossnay unit and one Lossnay remote controller. Lossnay unit can be controlled by Lossnay remote controller. All of Lossnay units can be controlled by centralized controller and ON/OFF remote controller, and each group can be controlled individually.
Group2	Multiple Lossnay units and two Lossnay remote controllers. Lossnay can be controlled by Lossnay remote controller. Up to 2 Lossnay remote controllers can be used in a group and they must be the same model. When 2 of PZ-61DR-E are used, one of them must be “sub” setting. For details, refer to the installation manual of PZ-61DR-E. When 2 Lossnay remote controllers are used, the last touch has a priority. All of Lossnay units can be controlled by centralized controller and ON/OFF remote controller, and each group can be controlled individually. Up to 15 Lossnay units can be connected in a group. It is necessary to connect the terminal TM4 ①② of each Lossnay units.
Group3	Multiple Lossnay units without remote controllers. All of Lossnay units can be controlled by centralized controller and ON/OFF remote controller, and each group can be controlled individually. Up to 16 Lossnay units can be connected in a group. It is NOT necessary to connect the terminal TM4 ①② of each Lossnay unit. (It is necessary to connect the terminal TM4 ①② of each Lossnay unit when the Night-purge function is used by a centralized controller.)

### 3.4.4 City Multi and Lossnay interlocked system

**<Feature>**

- Lossnay unit operation can be interlocked to City Multi indoor unit.
- ON/OFF and fan speed switching of Lossnay unit can be performed by MA remote controller.
- When Lossnay remote controller is used, the last touch of Lossnay remote controller or MA remote controller has a priority.
- The ventilation mode is automatically selected by the operation mode of City Multi.

**<Caution>**

- All Lossnay units require an address.
- One Lossnay unit can be interlocked to up to 16 indoor units.
- Indoor unit can NOT be interlocked to 2 or more Lossnay units.
- MA remote controller can switch Lossnay fan speed "High" / "Low".
- When not using ON/OFF remote controller PAC-YT40ANRA, the power supply unit is not necessary.

**<System example 2>**

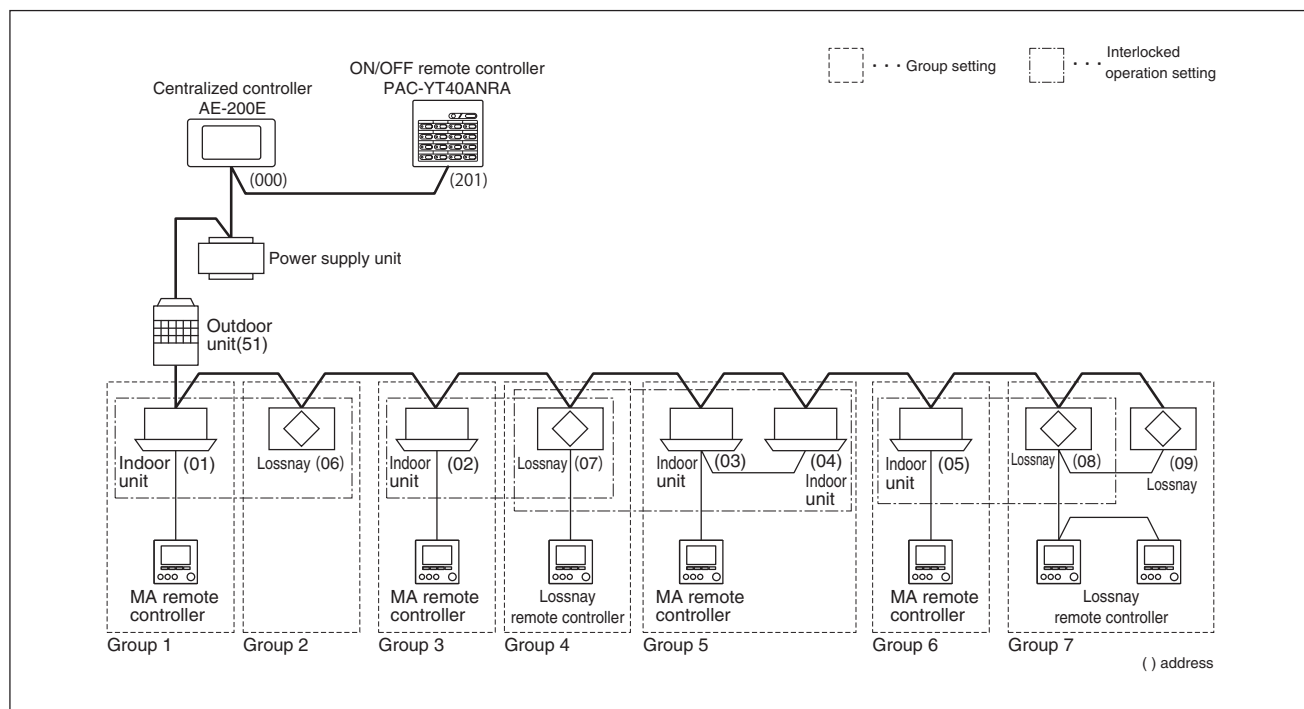

Group	Feature
Group2	One Lossnay unit which are interlocked to indoor unit of group 1. Operation of Lossnay unit can be performed by MA remote controller. All of Lossnay units can be controlled by centralized controller and ON/OFF remote controller, and each group can be controlled individually.
Group4	One Lossnay unit which is interlocked to multiple indoor units. Operation of Lossnay unit can be performed by Lossnay remote controller and 2 MA remote controllers. The last touch of Lossnay remote controller or MA remote controller has a priority. All of Lossnay units can be controlled by centralized controller and ON/OFF remote controller, and each group can be controlled individually. One Lossnay unit can be interlocked to up to 16 indoor units.
Group7	Multiple Lossnay units which are interlocked to indoor unit of group 6. Operation of Lossnay unit can be performed by 2 Lossnay remote controllers and MA remote controller. The last touch of Lossnay remote controller or MA remote controller has a priority. Up to 2 Lossnay remote controllers can be used in a group and they must be the same model. When 2 PZ-61DR-Es are used, one of them must be done "sub" setting. For details, refer to the installation manual of PZ-61DR-E. All of Lossnay units can be controlled by centralized controller and ON/OFF remote controller, and each group can be controlled individually. Up to 15 Lossnay units can be connected in a group. It is necessary to connect the terminal TM4 ①② of each Lossnay units.

### 3.4.5 System configuration of more than 50 units (Lossnay and indoor units)

<Feature>

- One AE-200E can control maximum 50 units (including Lossnay). Up to 200 units (including Lossnay) can be controlled from one AE-200E connected with three AE-50E.
- The integrated centralized control software TG-2000A can manage maximum 2000 units.
- For details, refer to City Multi technical manual and other manuals.

<System example 3>

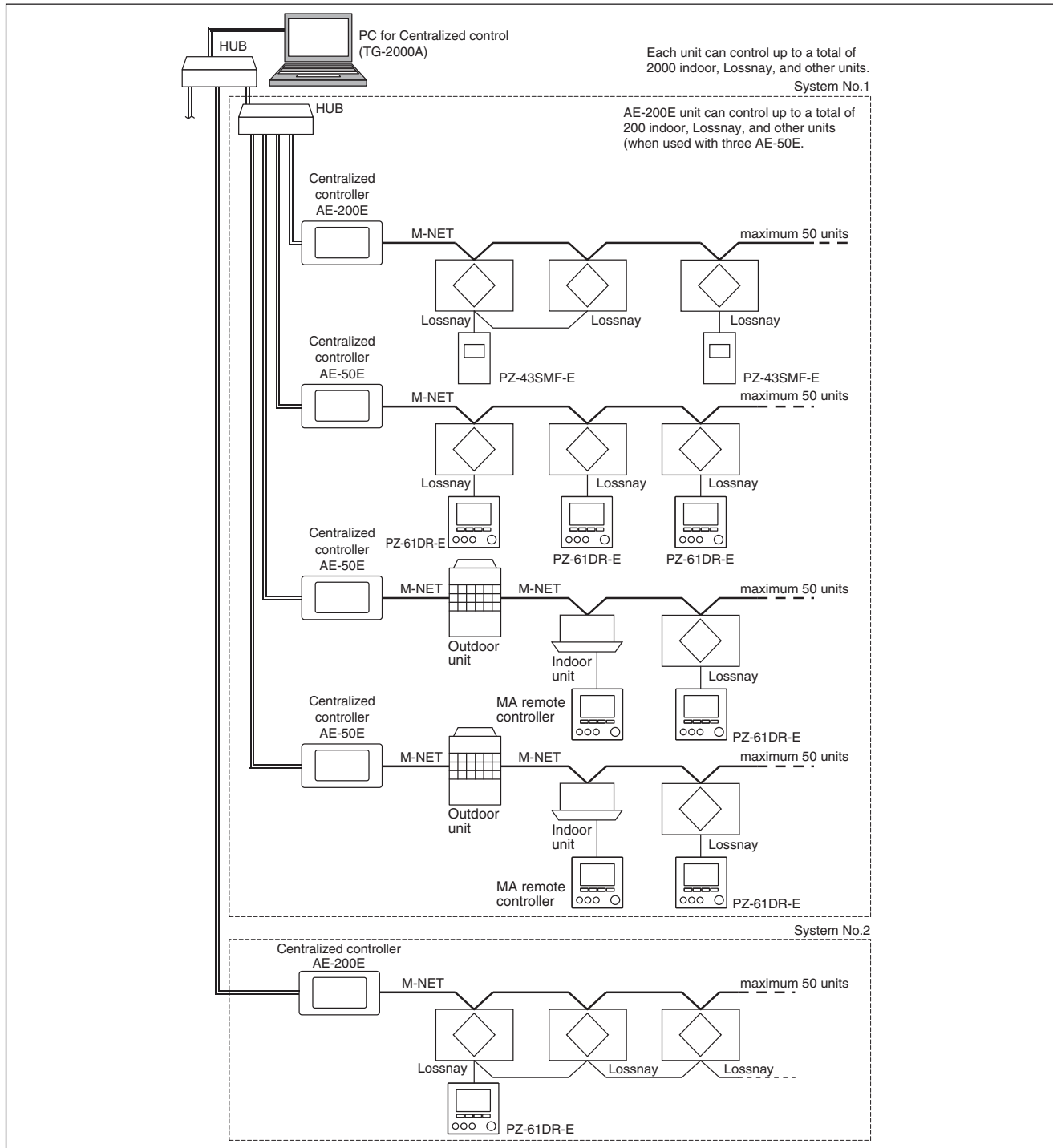

Group	Feature
All	All of indoor and Lossnay units can be controlled by the PC for centralized control.
System No. 1	All units of system No.1 can be controlled by centralized controller AE-200E in system No. 1. Each indoor and Lossnay unit can be controlled by each local remote controller.
System No. 2	All units of system No.2 can be controlled by centralized controller AE-200E in system No. 2. Lossnay unit can be controlled by Lossnay remote controller.



### 3.4.6 Interlocking system with system controller interface MAC-333IF-E

**<Feature>**

- Lossnay unit operation can be interlocked to RAC (M series) and Mr. Slim (S series) through system controller interface MAC-333IF-E.
- ON/OFF and fan speed switching of Lossnay unit can be performed by MA remote controller.
- When Lossnay remote controller is used, the last touch of Lossnay remote controller or MA remote controller has a priority.

**<Caution>**

- Select “External priority ON/OFF interlock mode” for interlocking mode otherwise the operation does not work properly. Refer to page C-23.
- One Lossnay unit can be interlocked to up to 16 indoor units.
- Indoor unit can NOT be interlocked to 2 or more Lossnay units.
- MA remote controller can switch Lossnay fan speed “High” / “Low”.
- When not using ON/OFF remote controller PAC-YT40ANRA, the power supply unit is not necessary.

**<System example 4>**

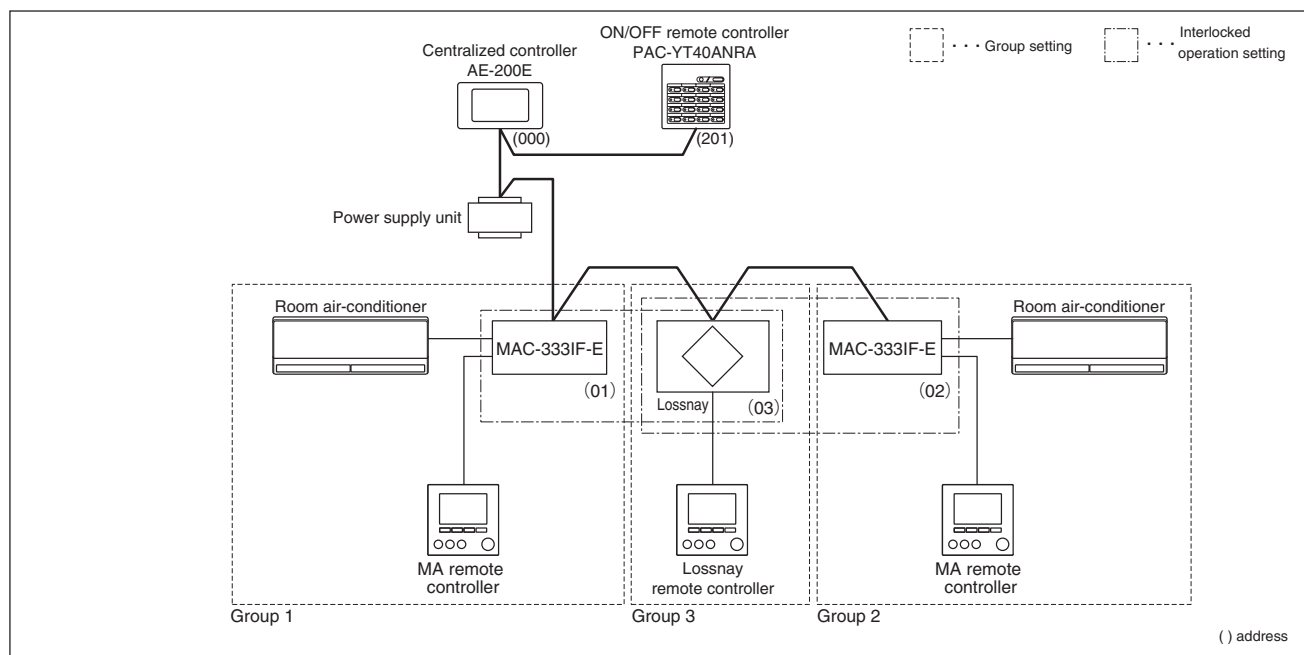

Group	Feature
Group 3	One Lossnay unit which is interlocked to multiple indoor units. Operation of Lossnay unit can be performed by Lossnay remote controller and 2 MA remote controllers. The last touch of Lossnay remote controller or MA remote controller has a priority. It is possible to control Lossnay unit from PZ-61DR-E when air-conditioner is off. Lossnay unit can be controlled by centralized controller and ON/OFF remote controller. It is impossible to stop Lossnay unit when air-conditioner is operating. One Lossnay unit can be interlocked to up to 16 indoor units.

**3.4.7 Automatic-address-start-up function**

**<Feature>**

- Under the following conditions, Lossnay can be automatically interlocked to indoor unit without setting the address of Lossnay unit.  
 There is indoor unit(s) in a system.  
 There is only one Lossnay unit in a system.  
 There are NO outdoor-air processing units (GUF series) in a system.

**<How to use Automatic-address-start-up function>**

- Set the address of Lossnay and indoor units as "00" (factory setting).
- There are some limitations other than above. For details, contact your dealer.

**<System example 4>**

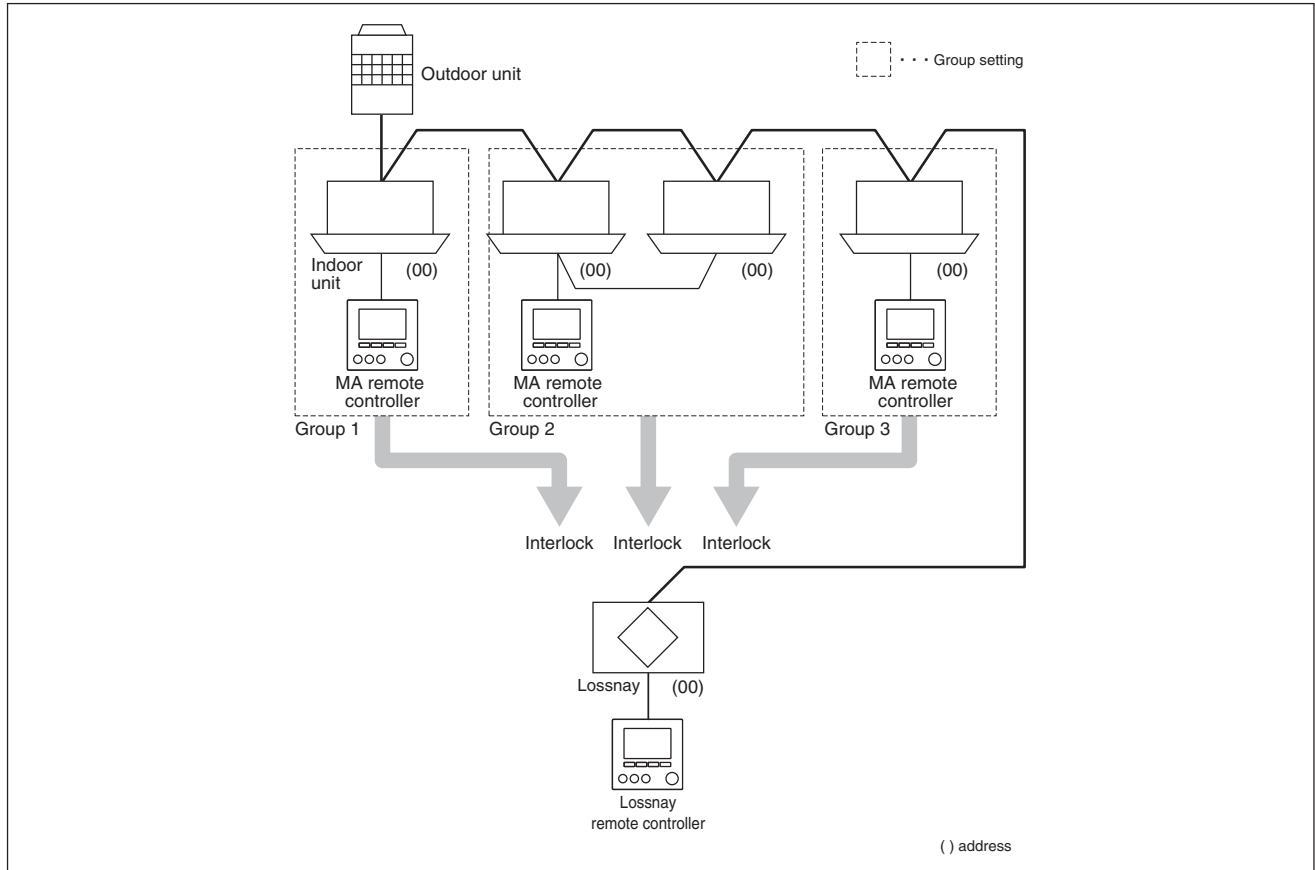

**<Function explanation>**

- Lossnay unit is interlocked to all of indoor units.
- One Lossnay unit can be interlocked to up to 16 indoor units.

### 3.5 Interlocked system with an external device

ON/OFF operation of Lossnay unit is possible by the input signal from an air-conditioner, a BMS (Building Management Systems) etc. to the terminal (TM2 ① ~ ③) of Lossnay PCB.

The type of input signal shall be volt-free contact or 12VDC/24VDC. Both level signal and pulse signal are available.

**<Caution>**

City Multi and Mr. Slim can NOT be interlocked to Lossnay unit together with an external device.

#### 3.5.1 How to use

An external signal should be connected to the terminal (TM2 ① ~ ③) of Lossnay PCB. Maximum wiring length and the exact terminal number depend on the type of signal.

Type of signal	Max wiring length	Terminal
Volt-free contact	500m	<p><b>&lt;Caution&gt;</b> When use a relay contact, follow the usage conditions below; Rating: 15VDC/0.1A or more    Min: 1mA or less When use a signal with polarity, the minus side should be connected to TM2 ①, the plus side should be connected to TM2 ③.</p>
24VDC or 12VDC	See manual of the external device	<p><b>&lt;Caution&gt;</b> TM2 ①② is a non-polar terminal. The input signal should follow the usage conditions below; Voltage: 24VDC or 12VDC    Current: 0.1A or more</p>

**(1) Wiring**

Use 0.5 mm<sup>2</sup> to 1.5 mm<sup>2</sup> sheathed PVC cable for wiring.

The signal wire should be away from the power cable and the wires of remote controller more than 5cm.

**(2) Level signal**

The duration of ON and OFF should be 10 seconds or more.

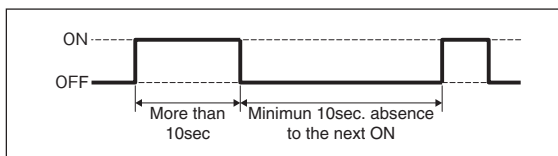

Type of signal	Lossnay operation
Volt-free contact	When the contact is closed, Lossnay is ON. When it is opened, Lossnay is OFF.
24VDC or 12VDC	When the signal has voltage, Lossnay is ON. When it is 0VDC, Lossnay is OFF.

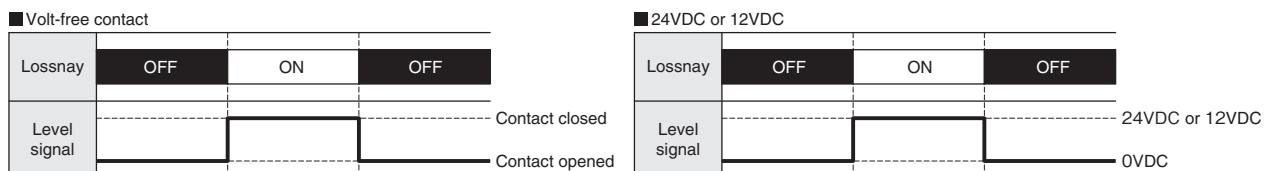

**(3) Pulse signal**

When using a pulse signal input, set the DIP-SW 2-2 ON or set the function **No.28** by PZ-61DR-E. See the table below.

DIP-SW		Setting check	PZ-61DR-E		Setting check	Pulse input setting
SW No.	Setting		Function No.	Setting Data		
SW2-2	-	-	28	0 (Factory setting)		DIP-SW priority
	OFF (Factory setting)			1		NOT pulse input
	ON			2		Pulse input

The duration of ON should be 200 msec. or more and 10 sec. or more absence is necessary to the next pulse .

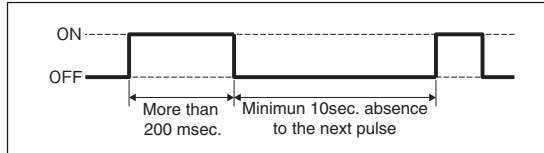

ON/OFF of Lossnay unit is inverted each time a pulse signal is inputted.

■ Volt-free contact

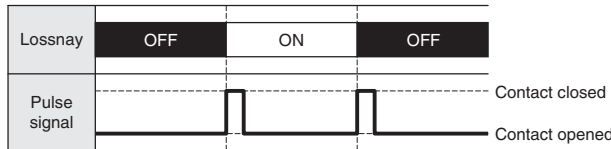

■ 24VDC or 12VDC

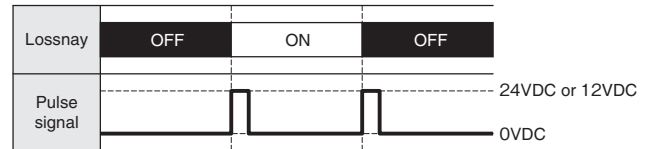

**<Caution>**

In conditions of pulse input is set to ON, following functions are not available.

- Delay start setting (Refer to page C-38)
- "External priority ON/OFF interlock mode" of interlock mode setting (Refer to page C-25)

**(4) Group control**

In the case that multiple Lossnay units are controlled by an input signal, follow the connection and setting below.

- Connect the terminal TM4 ①② of each Lossnay units.
- An input signal from the external device must be input to only one "main" Lossnay unit in a group.
- When Lossnay is in MELANS system, the "main" Lossnay unit should have the smallest address number in a group.

**(5) Interlocked to multiple external devices**

When the input signal is level signal, one Lossnay unit can be interlocked to multiple external devices.

- Lossnay unit turns ON when at least one external device is ON. Lossnay unit turns OFF when all external devices are OFF.

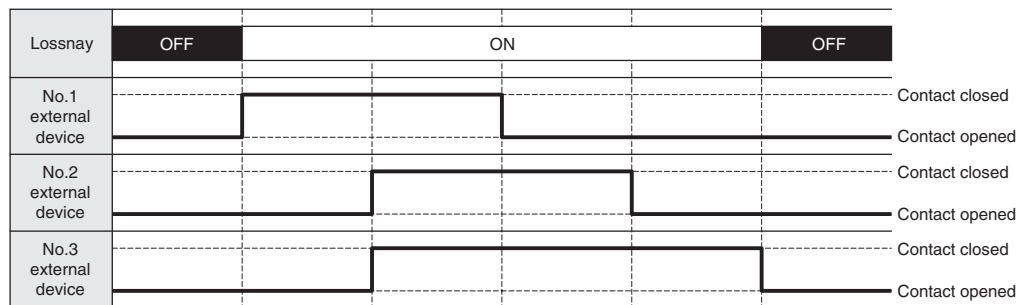

- When volt-free contact is used, make wiring as the picture below.

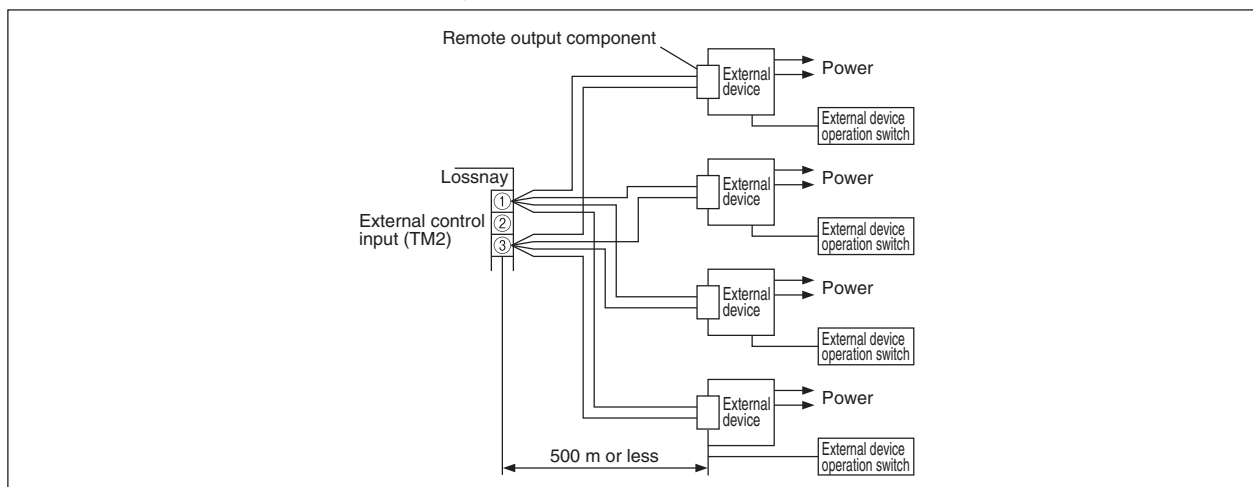

**(6) Operation monitor output** (Refer to page C-52)

The ON/OFF status of Lossnay can be checked by the operation monitor output.

When Lossnay unit is ON, the relay X15 of PCB (TM3 ⑨⑩) is closed.

The operation monitor output follows the external input signal with maximum 200 msec delay.

**(7) Malfunction monitor output** (Refer to page C-51)

When Lossnay unit is not connected to MELANS or Lossnay remote controller, the error monitor output function should be used to know the malfunction of Lossnay unit.

When Lossnay unit has an error, the relay X14 of PCB (TM3 ⑧⑩) is closed.

**3.5.2 Interlocked system with non-Mitsubishi air-conditioner**

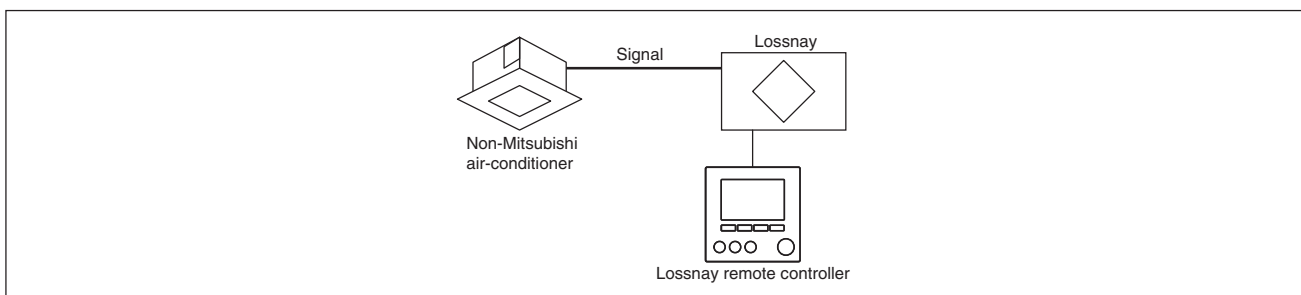

**<Feature>**

- Lossnay unit turns ON/OFF by a signal from an air-conditioner.
- Lossnay unit can be controlled, ON/OFF and fan speed switching, by Lossnay remote controller individually.
- When an error occurs, the error number will appear on Lossnay remote controller.

**<Caution>**

- When Lossnay remote controller is NOT connected, the fan speed is fixed at 4, the ventilation mode is fixed at automatic mode. Use malfunction monitor output function to notice Lossnay error.

3.5.3 Interlocked system with BMS (Building Management Systems)

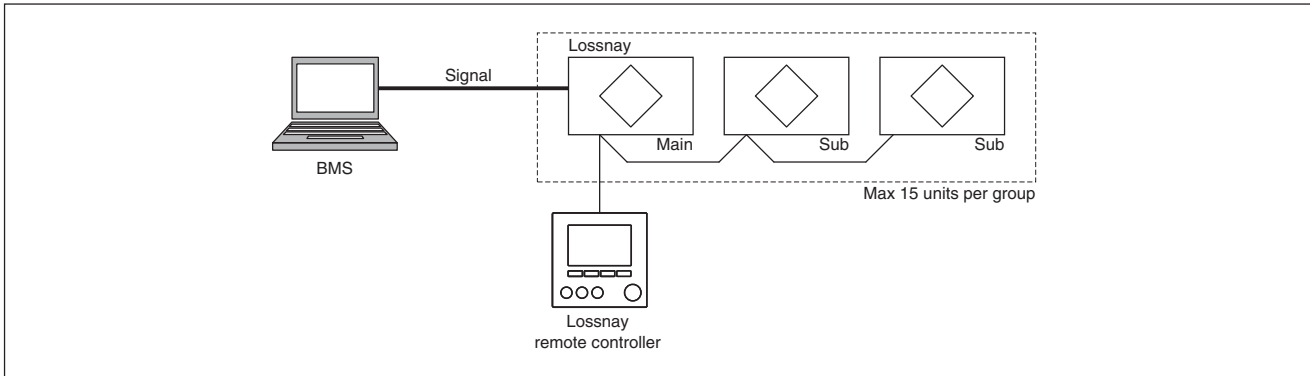

<Feature>

- Lossnay unit turns ON/OFF by a signal from BMS, also fan speed switching is available by analogue 0-10VDC input. For details, refer to page C-54.
- Lossnay unit can be controlled, ON/OFF and fan speed switching, by Lossnay remote controller individually.
- When an error occurs, the error number will appear on Lossnay remote controller.

<Caution>

- When Lossnay remote controller is NOT connected, the fan speed is fixed at 4, the ventilation mode is fixed at automatic mode. Use malfunction monitor output function to notice Lossnay error.

3.5.4 Combination system of MELANS and external devices

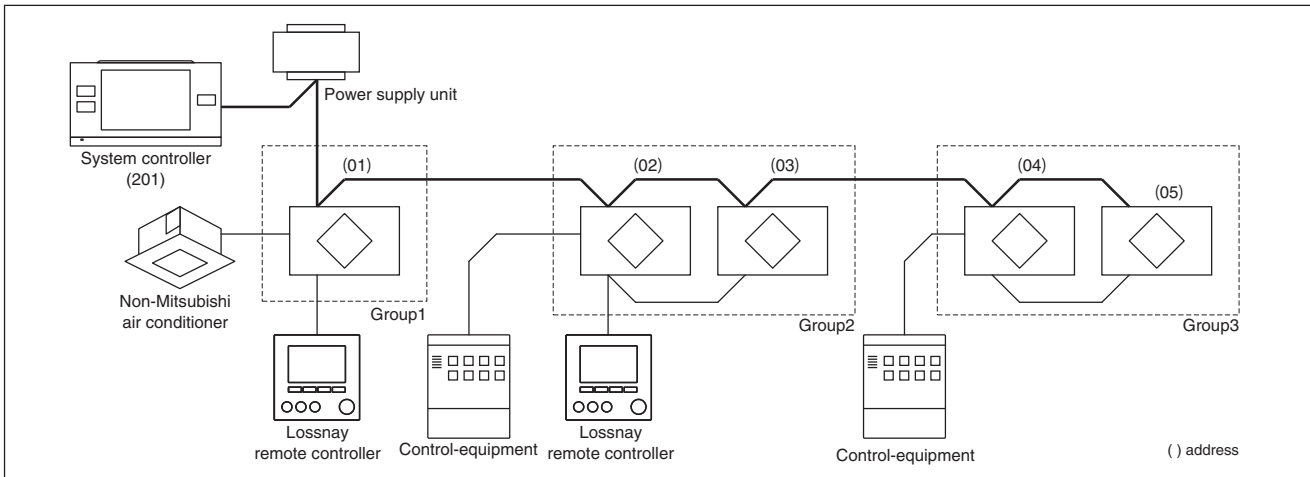

Group	Feature
Group1	MELANS control Lossnay unit. Lossnay unit is interlocked with non-Mitsubishi air-conditioner. Lossnay unit turns ON/OFF by a signal from the air-conditioner. Lossnay unit can be controlled, ON/OFF or fan speed switching, by Lossnay remote controller or system controller individually. When an error occurs, the error number will appear on Lossnay remote controller and system controller.
Group2	MELANS control Lossnay unit. Lossnay unit is interlocked to a control-equipment. Lossnay unit turns ON/OFF by a signal from a control-equipment. Lossnay unit can be controlled, ON/OFF or fan speed switching, by Lossnay remote controller or system controller individually. When an error occurs, the error number will appear on Lossnay remote controller and system controller.
Group3	MELANS control Lossnay unit. Lossnay unit is interlocked to a control-equipment. Group 3 is an example as same as group 2 other than Lossnay remote controller. Lossnay unit turns ON/OFF by a signal from a control-equipment. Lossnay unit can be controlled, ON/OFF or fan speed switching, by system controller individually. When an error occurs, the error number will appear on system controller.

### 3.5.5 Interlock mode setting (External control operating mode)

There are four operation modes of interlocked system from external devices.

- a: ON/OFF interlock mode (Factory setting)
- b: ON interlock mode
- c: OFF interlock mode
- d: External priority ON/OFF interlock mode

**<How to select the mode>**

Set the DIP-SW 5-7 and 5-8 or function setting of PZ-61DR-E as the table below.

DIP-SW		Setting check	PZ-61DR-E		Setting check	Interlock setting
SW No.	Setting		Function No.	Setting Data		
SW5-7 SW5-8	-	-	15	0 (Factory setting)		DIP-SW priority
	5-7 OFF 5-8 OFF (Factory setting)			1		a) ON/OFF interlock mode
	5-7 ON 5-8 OFF			2		b) ON interlock mode
	5-7 OFF 5-8 ON			3		c) OFF interlock mode
	5-7 ON 5-8 ON			4		d) External priority ON/OFF interlock mode

**<Caution>**

- DO NOT set "d) External priority ON/OFF interlock mode", when "pulse signal input setting" is ON by the DIP-SW 2-2 or the function setting **No.28** by PZ-61DR-E.
- When interlocked with MITSUBISHI A/C, "a) ON/OFF interlock mode" and "d) External priority ON/OFF interlock mode" are available. Do NOT set to other mode.
- In the case that PZ-61DR-E is used,
  - "⏻" icon appears on the display when both the Lossnay and external device are operating.
  - When "d) External priority ON/OFF interlock mode" is selected, "INTERLOCKED" is displayed for 3 seconds and ON/OFF button is invalid when both the Lossnay and external device is operating.
- In the case that PZ-43SMF-E is used,
  - "INTERLOCKED" is displayed when both the Lossnay and external device are operating.
  - When "d) External priority ON/OFF interlock mode" is selected, "CENTRAL" is also displayed and ON/OFF button is invalid when both the Lossnay and external device is operating.
- In the case that system controller is used
  - No special indicator on the display.
  - When "d) External priority ON/OFF interlock mode" is selected, ON/OFF button is invalid when both the Lossnay and external device is operating. (The display changes to OFF when pressing ON/OFF button, but it returns soon.)

**a) ON/OFF interlock mode (Factory setting)**

Lossnay unit turns ON externally.

Lossnay unit turns OFF externally.

Regardless of the signal of external device, Lossnay unit can be controlled by Lossnay remote controller and MELANS controller.

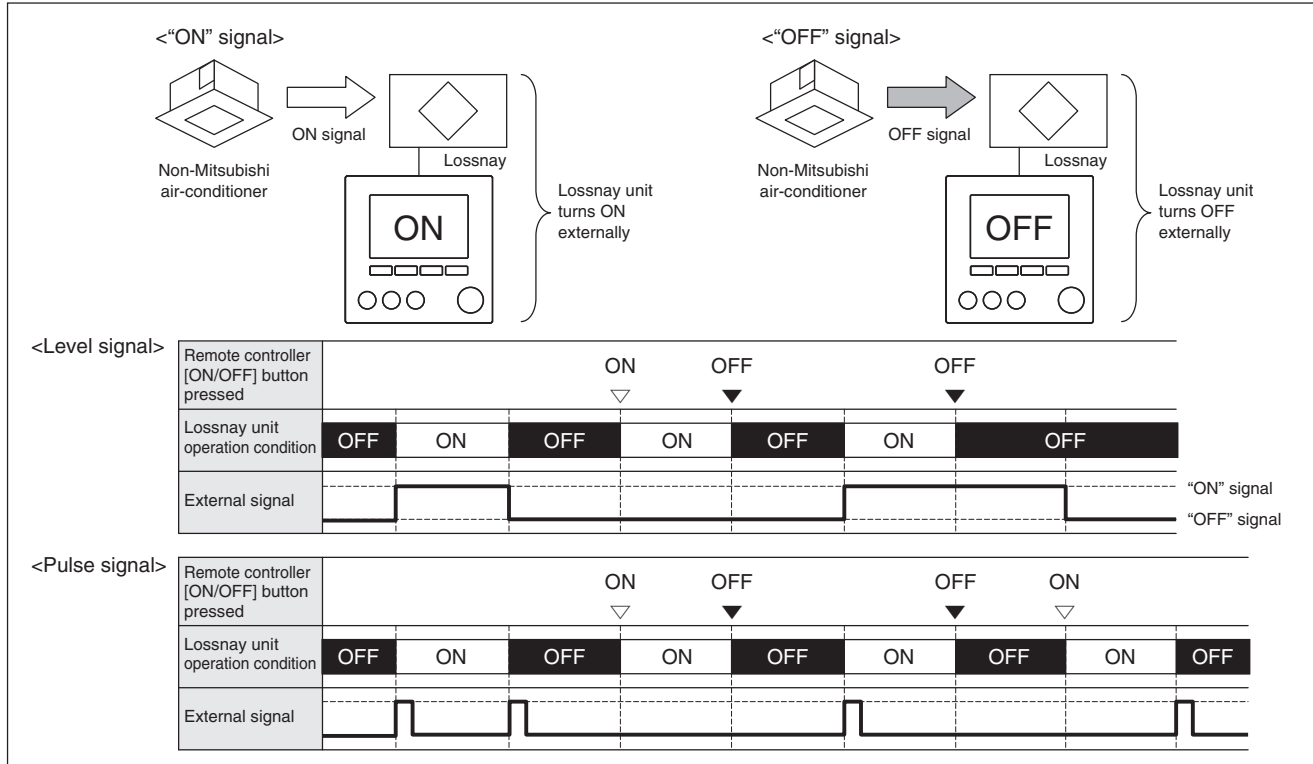

**b) ON interlock mode**

Lossnay unit turns ON externally.

Lossnay unit does not turn OFF externally.

Regardless of the signal of external device, Lossnay unit can be controlled by Lossnay remote controller and MELANS controller.

Note; This mode is not available when Lossnay is interlocked with Mr.Slim or C/M indoor unit via TM2①~③.

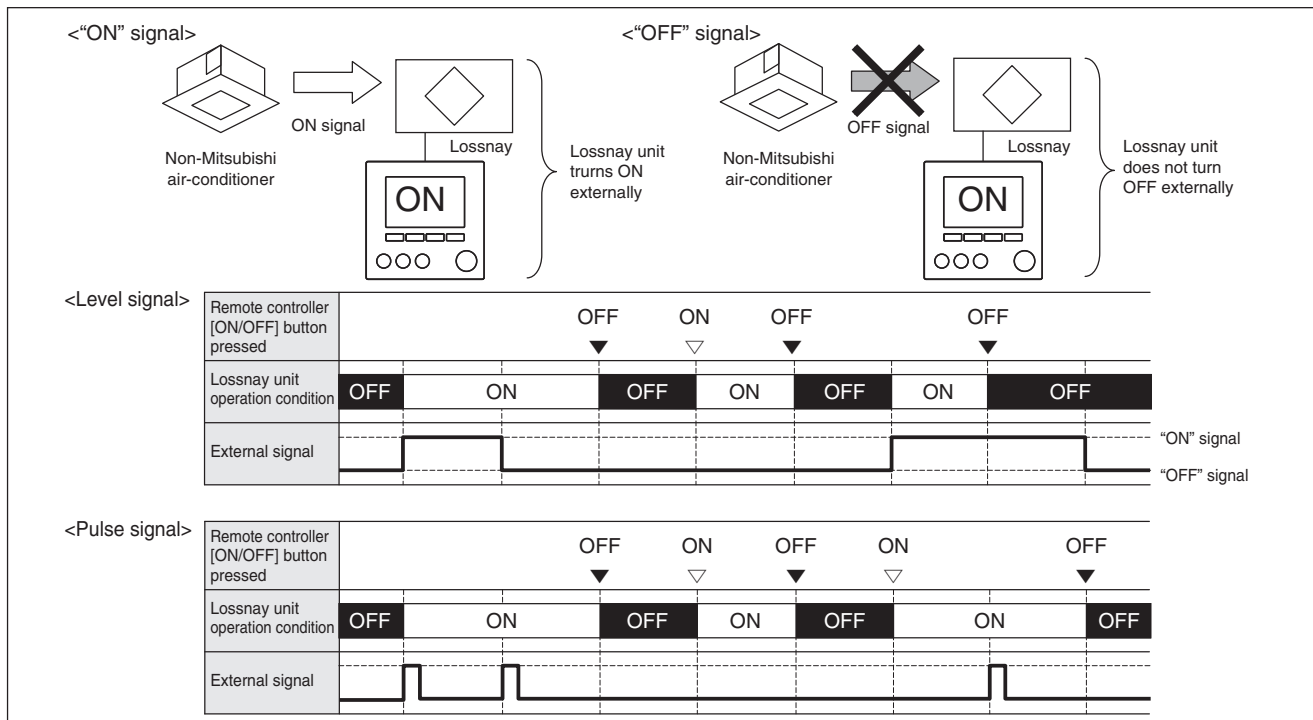



**c) OFF interlock mode**

Lossnay unit does not turn ON externally.

Lossnay unit turns OFF externally.

Regardless of the signal of external device, Lossnay unit can be controlled by Lossnay remote controller and MELANS controller.

Note; This mode is not available when Lossnay is interlocked with Mr.Slim or C/M indoor unit via TM2①~③.

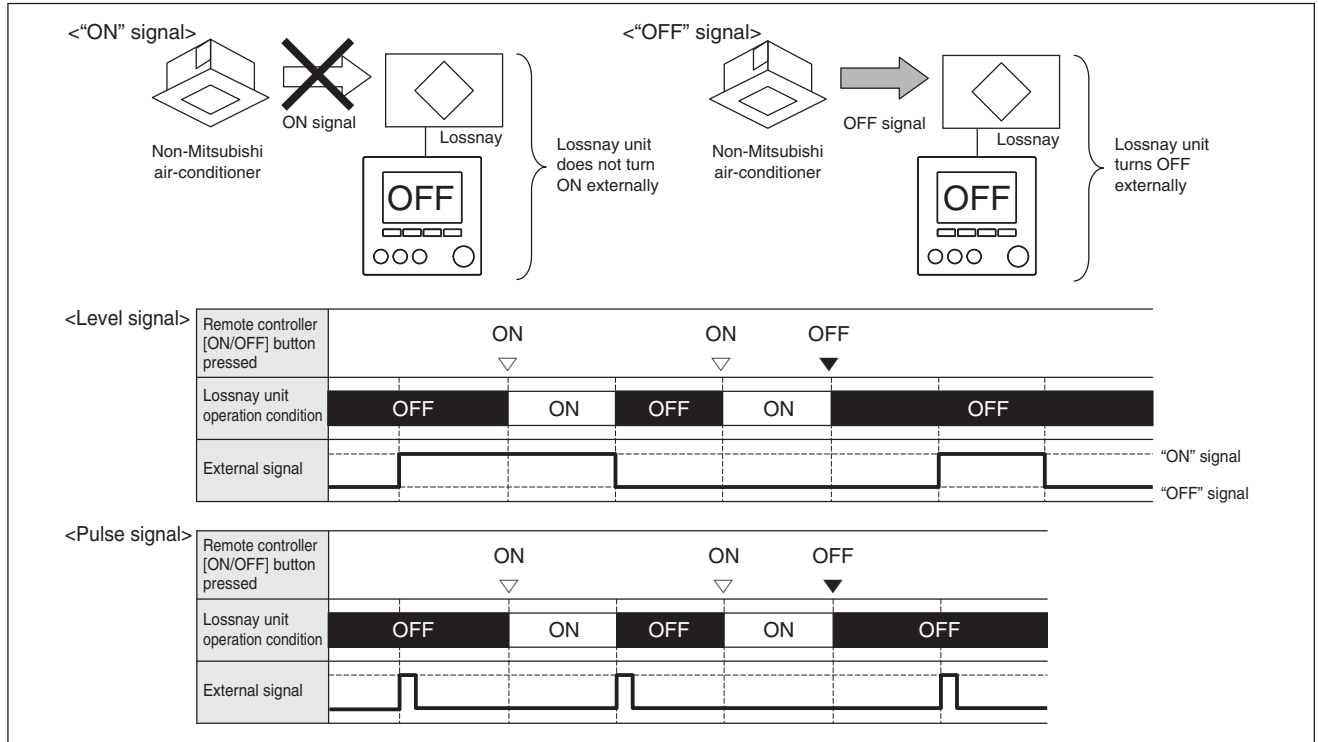

**d) External priority ON/OFF interlock mode**

Lossnay unit turns ON externally.

Lossnay unit turns OFF externally.

During Lossnay unit is operating by signal of external device, Lossnay can NOT be turned OFF by Lossnay remote controller or MELANS controller.

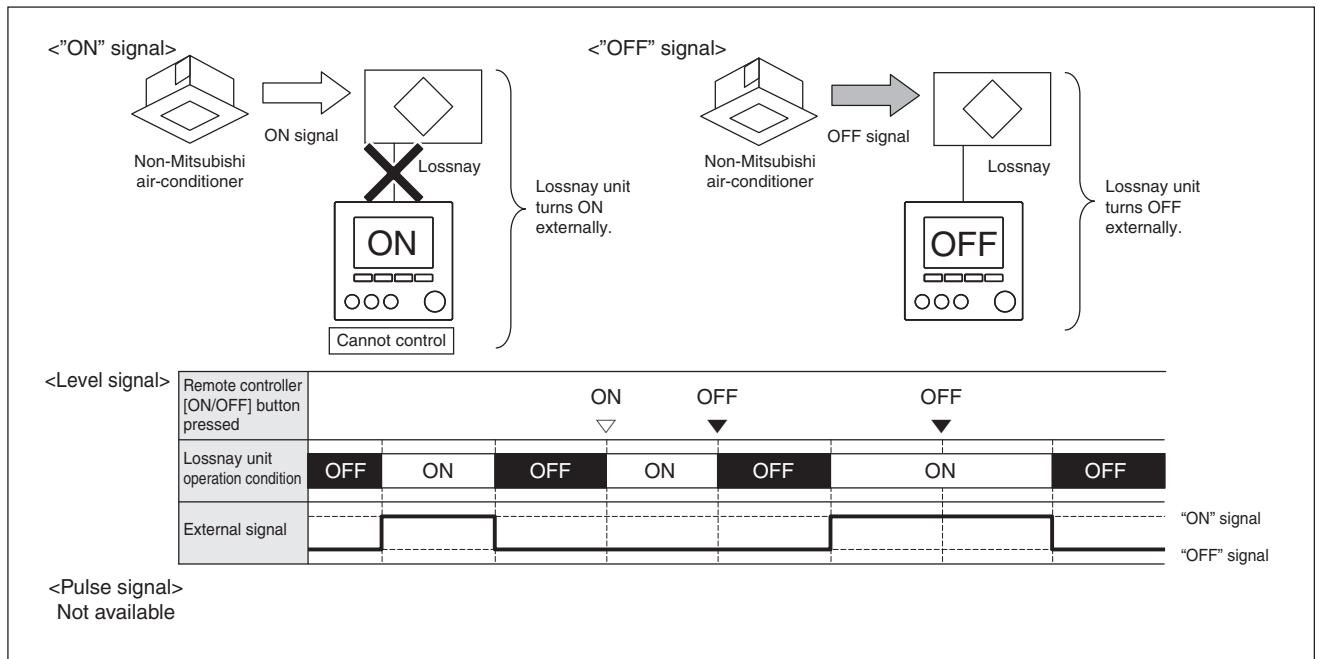

Note; This mode is NOT available with pulse signal.



## 1. Comparison of Lossnay remote controller

LGH-RVX-E series can be connected to 2 types of Lossnay remote controllers.

### <Appearance>

Lossnay remote controller	PZ-61DR-E	PZ-43SMF-E
Exterior		
Size	120x120x19mm	120x70x15mm
Color	Munsell 1.0Y9.2/0.2	Munsell 1.0Y9.2/0.2

### <Installation>

Remote controller	PZ-61DR-E	PZ-43SMF-E
M-NET address	No need	No need
Main/Sub setting	Necessary when using 2 remote controllers in a group	No need
Lossnay connection	Any Lossnay unit is OK as long as it is in the same group.	
Group change	<ul style="list-style-type: none"> <li>Not available from Lossnay RC. Setting from system controller is necessary.</li> <li>Also the wiring between Lossnay units and RC should be rechecked and modified.</li> </ul>	
Max No. of remote controller in a group	2	2
Features	<ul style="list-style-type: none"> <li>Same face with Mitsubishi A/C RC</li> <li>Various functions like weekly timer Night-purge, Bypass free setting etc. are available.</li> </ul>	<ul style="list-style-type: none"> <li>Basic functions like ON/OFF, fan speed switching and ventilation mode selecting are available.</li> <li>Small installation space</li> </ul>

\*It is NOT available to use both PZ-61DR-E and PZ-43SMF-E in a group.

### <Function>

Function (Communicating mode)	PZ-61DR-E	PZ-43SMF-E
Fan speed selection	4 fan speeds	2 of 4 fan speeds
Ventilation mode selection	Energy recovery / Bypass / Automatic	Energy recovery / Bypass / Automatic
Night-purge (time)	Any time selectable	No
Night-purge (fan speed)	Selectable from 4 fan speeds	No
DIP-SW setting and function setting from RC	Yes	No
Bypass temp. free setting	Yes	No
Pre-heater control free setting	Yes	No
Fan power up after installation	Yes	No
0 - 10VDC external input	Yes	Yes
ON/OFF timer	Yes	Yes*
Auto-Off timer	Yes	No
Weekly timer	Yes	No
Operation restrictions (ON/OFF, Ventilation mode, fan speed)	Yes	No
Operation restrictions (Fan speed skip setting)	Yes	No
Screen contrast adjustment	Yes	No
Language selection	Yes (8 languages)	No (English only)
Initializing remote controller	Yes	No
Filter cleaning sign	Yes	Yes
Lossnay core cleaning sign	Yes	No
Error indication	Yes	Yes
Error history	Yes	No
OA/RA/SA temp. display	Yes	No

\*ON/OFF timer of PZ-43SMF-E : count-down timer to Lossnay ON/OFF

## 2. Function setting

### 2.1 Model selection switch

DIP-SW 6 is to identify the model for PCB. When replacing to new PCB, set the same setting as old one.

#### DIP-SW6

	DIP-SW6-1	DIP-SW6-2	DIP-SW6-3	DIP-SW6-4
LGH-15RVX-E	ON	OFF	OFF	OFF
LGH-25RVX-E	OFF	ON	OFF	OFF
LGH-35RVX-E	ON	ON	OFF	OFF
LGH-50RVX-E	OFF	OFF	ON	OFF
LGH-65RVX-E	ON	OFF	ON	OFF
LGH-80RVX-E	OFF	ON	ON	OFF
LGH-100RVX-E	ON	ON	ON	OFF
LGH-150RVX-E	OFF	OFF	OFF	ON
LGH-200RVX-E	ON	OFF	OFF	ON

\* Do not change from factory setting. If changed, please set as factory setting.

### 2.2 Function selection switches (DIP-SW 2, 5)

Set the selection switches (DIP-SW 2, 5) to perform the appropriate function.

- All function except trial operation and main unit setting can be set also from PZ-61DR-E.  
If the function is switched by PZ-61DR-E. Setting from PZ-61DR-E has priority to DIP-SW except "DIP-SW priority" setting of PZ-61DR-E.
- Shut down the power supply before setting the switches (except DIP-SW2-1).
- Depending on system configuration, some functions may be not available.
- When replacing to new PCB, set the same setting as old one.

#### DIP-SW2

	OFF	ON	
1	<input type="checkbox"/>	<input type="checkbox"/>	Trial operation
2	<input type="checkbox"/>	<input type="checkbox"/>	No. 28 Pulse input setting
3	<input type="checkbox"/>	<input type="checkbox"/>	No. 63 External fan speed input setting (0 - 10 VDC)
4	<input type="checkbox"/>	<input type="checkbox"/>	No. 6 Indoor negative pressure setting
5	<input type="checkbox"/>	<input type="checkbox"/>	No. 7 Indoor positive pressure setting
6	<input type="checkbox"/>	<input type="checkbox"/>	No. 63 External fan speed input setting (0 - 10 VDC)
7	<input type="checkbox"/>	<input type="checkbox"/>	No. 51 Automatic ventilation mode setting
8	<input type="checkbox"/>	<input type="checkbox"/>	No. 57 Operation monitor output synchronized with exhaust fan or supply fan
9	<input type="checkbox"/>	<input type="checkbox"/>	No. 61 Fan speed for air volume "High" input
10	<input type="checkbox"/>	<input type="checkbox"/>	No. 62 Fan speed for air volume "Low" input

#### DIP-SW5

	OFF	ON	
1	<input type="checkbox"/>	<input type="checkbox"/>	No. 9 Delay start setting for air conditioner starting
2	<input type="checkbox"/>	<input type="checkbox"/>	No. 57 Operation monitor output synchronized with exhaust fan or supply fan
3	<input type="checkbox"/>	<input type="checkbox"/>	No. 13, No. 14 Exhaust fan setting
4	<input type="checkbox"/>	<input type="checkbox"/>	No. 5 Automatic recovery setting after power interruption
5	<input type="checkbox"/>	<input type="checkbox"/>	No. 1 Filter maintenance and fan power up setting against filter choking
6	<input type="checkbox"/>	<input type="checkbox"/>	No. 58 Bypass monitor output or pre-heater output setting
7	<input type="checkbox"/>	<input type="checkbox"/>	No. 15 Interlock mode setting
8	<input type="checkbox"/>	<input type="checkbox"/>	No. 15 Interlock mode setting
9	<input type="checkbox"/>	<input type="checkbox"/>	No. 14 Exhaust fan setting at OA temperature lower than -15°C
10	<input type="checkbox"/>	<input type="checkbox"/>	Main unit setting (Refer to page C-9)

No. \*\* Shows the function No. which can be set from remote controller PZ-61DR-E

## 2.3 Function setting from PZ-61DR-E

### 2.3.1 Function list

No	Function	Setting Data								Factory setting	DIP-SW No.	Reference page	Individual setting
		0	1	2	3	4	5	6	7				
*1	Filter maintenance and fan power up setting against filter choking	DIP-SW priority	Indicator available Fan power up N/A	Indicator N/A Fan power up N/A	Indicator available Fan power up available	-	-	-	-	0	5-5	C-31	-
2	Lossnay core maintenance indicator setting	N/A	Available	-	-	-	-	-	-	0	N/A	C-31	-
5	Automatic recovery setting after power interruption	DIP-SW priority	Stop when the power is ON	Start when the power is ON	Return to the state before interruption	-	-	-	-	0	5-4	C-31	-
6	Indoor negative pressure setting	DIP-SW priority	N/A	Supply 1 down	Supply 2 down	-	-	-	-	0	2-4	C-37	○
7	Indoor positive pressure setting	DIP-SW priority	N/A	Exhaust 1 down	Exhaust 2 down	-	-	-	-	0	2-5	C-38	○
8	Max. fan speed setting during the first 30 minutes	N/A	Available	-	-	-	-	-	-	0	N/A	C-38	○
9	Delay start setting for air conditioner starting	DIP-SW priority	N/A	15 min	30 min	-	-	-	-	0	5-1	C-38	-
13	Exhaust fan setting during air conditioner defrosting	DIP-SW priority	Stop	No change	-	-	-	-	-	0	5-3	C-39	-
14	Exhaust fan setting at OA temperature lower than -15 °C	DIP-SW priority	Stop	Fan speed 1 or 2	No change	-	-	-	-	0	5-3 5-9	C-39	-
15	Interlock mode setting	DIP-SW priority	ON/OFF interlock	ON interlock	OFF interlock	External input given priority	-	-	-	0	5-7 5-8	C-23	-
28	Pulse input setting	DIP-SW priority	Non-pulse input	Pulse input	-	-	-	-	-	0	2-2	C-20	-
*30	Night-purge setting 1) Air volume	N/A	Fan speed 1	Fan speed 2	Fan speed 3	Fan speed 4	-	-	-	0	N/A	C-47	-
*31	Night-purge setting 2) Outdoor and indoor temperature difference	0 °C	1 °C	2 °C	3 °C	4 °C	5 °C	6 °C	7 °C	5	N/A	C-47	-
*32	Night-purge setting 3) Threshold of outdoor temperature	Setting Data 0 to 15 --> Threshold temperature for Night-purge 15 °C to 30 °C								2	N/A	C-47	-
*34	Input priority setting	Main unit input priority	Individual input priority	-	-	-	-	-	-	0	N/A	C-57	○
36	Outdoor temperature display setting	N/A	Available	-	-	-	-	-	-	0	N/A	C-33	-
37	Indoor temperature display setting	N/A	Available	-	-	-	-	-	-	0	N/A	C-33	-
38	Calculated supply air temperature display setting	N/A	Available	-	-	-	-	-	-	0	N/A	C-33	-
39	Temperature exchange efficiency setting (tens digit)	Setting Data 0 to 9 --> tens digit of temperature exchange efficiency 0 to 9								7	N/A	C-34	-
40	Temperature exchange efficiency setting (ones digit)	Setting Data 0 to 9 --> ones digit of temperature exchange efficiency 0 to 9								0	N/A	C-34	-
*41	Outdoor temperature correction	Setting Data 0 to 14 --> Outdoor temperature correction -7 °C to 7 °C								7	N/A	C-35	-
*42	Indoor temperature correction	Setting Data 0 to 14 --> Room temperature correction -7 °C to 7 °C								7	N/A	C-35	-
*51	Automatic mode setting	DIP-SW priority	Pattern A	Pattern B	Free setting	-	-	-	-	0	2-7	C-43	-
*52	Automatic mode setting 1) Outdoor and indoor temperature difference	Setting Data 0 to 7 --> Temperature difference 0 °C to 7 °C								0	N/A	C-44	-
*53	Automatic mode setting 2) The lowest outdoor temperature setting	Setting Data 0 to 15 --> Lowest outdoor temperature 10 °C to 25 °C								6	N/A	C-44	-
*54	Automatic mode setting 3) The lowest indoor temperature setting	Setting Data 0 to 15 --> Lowest indoor temperature 15 °C to 30 °C								1	N/A	C-44	-
*55	Supply fan power up setting	N/A	1 level up	2 level up	3 level up	4 level up	-	-	-	0	N/A	C-40	○
*56	Exhaust fan power up setting	N/A	1 level up	2 level up	3 level up	4 level up	-	-	-	0	N/A	C-40	○
57	Operation monitor output synchronized with exhaust fan or supply fan	DIP-SW priority	Operation monitor output	SA fan monitor output	SA fan monitor with delay operation	-	-	-	-	0	2-8 5-2	C-52	○
58	Bypass monitor output or pre-heater output setting	DIP-SW priority	Bypass monitor output	Operation monitor output for pre-heater	-	-	-	-	-	0	5-6	C-51	○
*59	Pre-heater output setting 1) ON temperature	0 °C	-1 °C	-2 °C	-3 °C	-4 °C	-5 °C	-6 °C	-7 °C	0	N/A	C-48	○
*60	Pre-heater output setting 2) OFF interval	1 hr	2 hrs	3 hrs	4 hrs	5 hrs	-	-	-	0	N/A	C-49	○
*61	Fan speed for air volume "High" input	DIP-SW priority	Fan speed 4	Fan speed 3	-	-	-	-	-	0	2-9	C-40	-
*62	Fan speed for air volume "Low" input	DIP-SW priority	Fan speed 2	Fan speed 1	-	-	-	-	-	0	2-10	C-40	-
*63	External fan speed input setting (0 - 10 VDC)	DIP-SW priority	N/A	Pattern X	Pattern Y	Pattern Z	-	-	-	0	2-3 2-6	C-54	○
100	Initialization	-	Initialize	-	-	-	-	-	-	0	N/A	C-36	-

This table shows the summary of function settings. Please refer to the following pages for more details.

The functions indicated with \* are newly added or modified from Lossnay LGH-RX<sub>5</sub>-E series.

The functions indicated with "N/A" in the "DIP-SW No." column are available only when using with remote controller PZ-61DR-E.

The functions indicated with "○" in the "Individual setting" column are available to set the data for each Lossnay in the multiple Lossnay group individually. Refer to page C-30.

### 2.3.2 How to set function setting from PZ-61DR-E

Make the Lossnay units' function settings from PZ-61DR-E as necessary (Not available from PZ-43SMF-E).  
Every modified setting needs to be recorded to trace.

#### <Button operation>

1

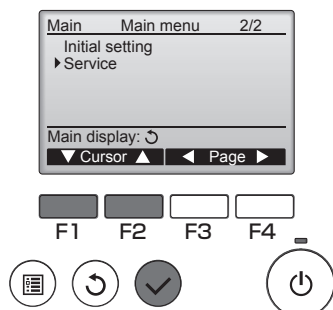

Press the **MENU** button.  
The main menu will appear.  
Select Service on the Main menu and press the **SELECT** button.

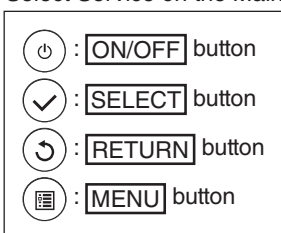

2

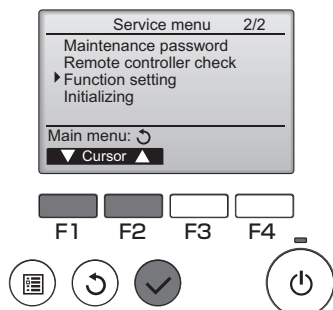

Select Function Setting on the Service Menu screen, and press the **SELECT** button.

3

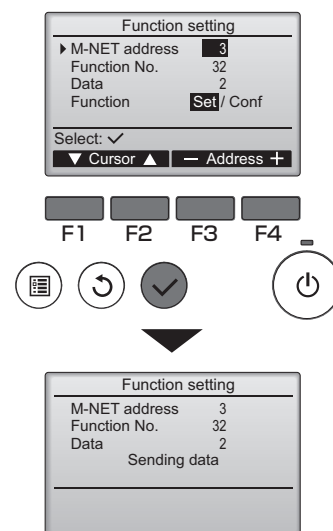

The Function Setting screen will appear.  
Press the **F1** or **F2** button to move the cursor to one of the following: M-NET address, function setting number, or setting value. Then, press the **F3** or **F4** button to change the settings to the desired settings.

Once the settings have been completed, press the **SELECT** button.  
A screen will appear that indicates that the settings information is being sent.

To check the current settings of a given unit, enter the setting for its M-NET address and function setting number, select Conf for the Function, and press the **SELECT** button.  
A screen will appear that indicates that the settings are being searched for. When the search is done, the current settings will appear.

4

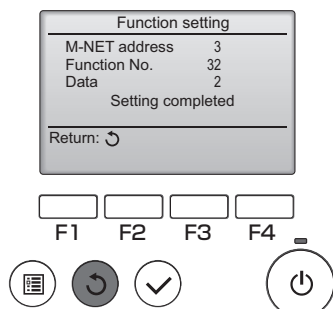

When the settings information has been sent, a screen will appear that indicates its completion.

To make additional settings, press the **RETURN** button to return to the screen shown in Step 3 above. Set the function numbers for other Lossnay units by following the same steps.

Navigating through the screens

- To return to the Service Menu screen ..... **MENU** button
- To return to the previous screen ..... **RETURN** button

**<Cautions of M-NET address setting>**

Only when each Lossnay has individual M-NET address, it is possible to do individual function setting by selecting its M-NET address. In other cases when address setting is not done, "All" should be selected for "M-NET address". In the case of multiple Lossnay units system, both "Bulk setting" and "Individual setting" is possible. Use "Bulk setting" for the functions which cannot be available to use "Individual setting". Refer to the table in page C-28.

- Bulk setting: Function setting data of all Lossnay units in a group become the same.
- Individual setting: Function setting data of each Lossnay unit can be set individually.
- To use "Bulk setting", select "All" for "M-NET address".
- To use "Individual setting", select address of the unit to be changed for "M-NET address".
- If the address setting is not done, only "Bulk setting" is available.
- Function setting data will be reset when address number is changed.

**Note;**

- By pressing F3 button, "M-NET address" is decreased by 1. ( ··· 2 → 1 → 0 → All → 127 → 126 ··· )
- By pressing F4 button, "M-NET address" is increased by 1. ( ··· 126 → 127 → All → 0 → 1 → 2 ··· )

## 3. Function setting contents

### 3.1 Trial Operation

After the system has been installed and before the ceiling panel is installed, make sure that wires are properly connected, then test the system's operation, referring to the operation manual for the remote controller.

#### 3.1.1 Trial operation using the remote controllers (PZ-61DR-E)

Follow the procedure shown in the operation manual for the remote controller the functions below.

- (1) Start operation.
- (2) Fan speed selection.
- (3) Ventilation mode selection.
- (4) Stop operation.

#### 3.1.2 Lossnay trial operation

This function can be used in the following situations.

- When there is no remote controller installed for operating the Lossnay.
- When heater output, malfunction monitor output, operation monitor output, and other output are connected.
- When the outdoor temperature is 8°C or lower. (To check Bypass damper operation)

- (1) Supply power to the Lossnay unit.
- (2) Turn the trial operation switch (DIP-SW2-1) "ON."

Terminal	DIP-SW	Setting	Minutes	0		1		2		3		4												
			Seconds	0	10	20	30	40	50	0	10	20	30	40	50	0	10	20	30	40	50	0	10	20
-	-	-	FanSpeed	STOP	4	STOP	4																	
-	-	-	Ventilation mode	Bypass		Lossnay																		
TM3⑦⑩	SW5-6	OFF	Bypass monitor output	OFF	ON		OFF																	
		ON	Pre-heater output	OFF				ON																
TM3⑨⑩	SW2-8/ SW5-2	OFF/OFF	EA fan monitor output	ON																				
		OFF/ON	SA fan monitor output	ON																				
		ON/OFF or ON/ON	SA fan monitor output delay operation	OFF						ON														
TM3⑧⑩	-	-	Malfunction monitor output	ON																				

Error code "0900" appears on the remote controller.

- (3) Check each function is operating normally.
- (4) Turn the trial operation switch (DIP-SW2-1) "OFF."

#### 3.1.3 Complete system trial operation

- Interlock system containing an indoor unit and/or external device
  - Use the remote controller for the indoor unit or the operating switches for the external device and confirm that the indoor unit and Lossnay are interlocked.
  - If delay time has been set, check that the Lossnay operates after the delay time has passed.
- If MELANS System
  - Use MELANS to confirm the operation of the Lossnay.

## 3.2 Pulse input setting

Refer to page C-20

## 3.3 Filter maintenance and fan power up setting against filter choking

Set the schedule for filter cleaning based on the estimated concentration of dust in the air. When fan power up is available, exhaust and supply fans power up at 1,000 hours and 2,000 hours gradually. If function **No.55** or **No.56** is already worked, fan power up function may not be available. Estimated hour differs by actual operated fan speed.

DIP-SW		Setting check	PZ-61DR-E		Setting check	Filter maintenance indicator	Fan power UP
SW No.	Setting		Function No.	Setting Data			
SW5-5	-	-	1	0 (Factory setting)		DIP-SW priority	
	-	-		1		Indicate at estimated 3,000 hrs	N/A
	OFF (Factory setting)			2		N/A	N/A
	ON			3		Indicate at estimated 3,000 hrs	Available

### <Caution>

- When the setting for the cumulative operation time of the Lossnay is exceeded, the filter cleaning icon will appear on the indoor unit remote controller or the Lossnay remote controller.  
After cleaning the filter, the filter cleaning icon can be reset. Refer to the Instruction book for the remote controller.
- When PZ-43SMF-E is connected, DIP-SW 5-5 should be turned ON to display filter sign and fan power up function also becomes effective.

## 3.4 Lossnay core maintenance indicator setting

Set to enable Lossnay core maintenance indicator. Estimated hour differs by actual operated fan speed. This function is N/A from Lossnay unit DIP-SW. Estimated hour differs by actual operated fan speed.

DIP-SW		Setting check	PZ-61DR-E		Setting check	Lossnay core maintenance indicator
SW No.	Setting		Function No.	Setting Data		
N/A	-	-	2	0 (Factory setting)		N/A
	-	-		1		Indicate at estimated 6,000 hrs

## 3.5 Automatic recovery setting after power interruption

Set for automatic recovery following power interruption.

DIP-SW		Setting check	PZ-61DR-E		Setting check	Automatic recovery
SW No.	Setting		Function No.	Setting Data		
SW5-4	-	-	5	0 (Factory setting)		DIP-SW priority
	OFF (Factory setting)			1		Stop when the power is on
	-	-		2		Start when the power is on
	ON			3		Lossnay returns to the state before interruption

### **3.6 Indoor negative pressure setting**

Refer to “Fan speed control ”(C-37).

### **3.7 Indoor positive pressure setting**

Refer to “Fan speed control ”(C-38).

### **3.8 Max. fan speed setting during the first 30 minutes**

Refer to “Fan speed control ”(C-38).

### **3.9 Delay start setting for air conditioner starting**

Refer to “Fan speed control ”(C-38).

### **3.10 Exhaust fan setting during air conditioner defrosting or at OA temperature lower than -15 °C**

Refer to “Fan speed control ”(C-39).

### **3.11 Interlock mode setting**

Refer to “Interlocked system with an external device”(C-23).

### **3.12 Pulse input setting**

Refer to “4.5 Interlocked system with an external device”(C-20).

### **3.13 Night-purge setting 1) Air volume**

Refer to “Night-purge function ”(C-47).

### **3.14 Night-purge setting 2) Outdoor and indoor temperature difference**

Refer to “Night-purge function ”(C-47).

### **3.15 Night-purge setting 3) Threshold of outdoor temperature**

Refer to “Night-purge function ”(C-47).

### **3.16 Input priority setting**

Refer to “Input terminal ”(C-57).



### 3.17 Outdoor temperature display setting

Set to display outdoor temperature detected by Lossnay unit thermistor or not.

It is also necessary that "Temp. display" is selected as "Yes" on initial setting menu of PZ-61DR-E. Refer to the installation manual of PZ-61DR-E

(During Night-purge, outdoor temperature is not displayed.)

DIP-SW		Setting check	PZ-61DR-E		Setting check	Outdoor temperature display
SW No.	Setting		Function No.	Setting Data		
N/A	-	-	36	0 (Factory setting)		N/A
	-	-		1		Display on the screen of PZ-61DR-E

\*Outdoor temp. display flashes when 0°C or lower and 38°C or higher.

### 3.18 Indoor temperature display setting

Set to display indoor temperature detected by Lossnay unit thermistor or not.

It is also necessary that "Temp. display" is selected as "Yes" on initial setting menu of PZ-61DR-E. Refer to the installation manual of PZ-61DR-E

(During Bypass ventilation and Night-purge, indoor temperature is not displayed.)

DIP-SW		Setting check	PZ-61DR-E		Setting check	Indoor temperature display
SW No.	Setting		Function No.	Setting Data		
N/A	-	-	37	0 (Factory setting)		N/A
	-	-		1		Display on the screen of PZ-61DR-E

\*Indoor temp. display flashes when 8°C or lower and 38°C or higher

### 3.19 Calculated supply air temperature display setting

Set to display calculated supply air temperature or not.

It is also necessary that "Temp. display" is selected as "Yes" on initial setting menu of PZ-61DR-E. Refer to the installation manual of PZ-61DR-E

(During Bypass ventilation and Night-purge, calculated supply air temperature is not displayed.)

DIP-SW		Setting check	PZ-61DR-E		Setting check	Calculated supply air temperature display
SW No.	Setting		Function No.	Setting Data		
N/A	-	-	38	0 (Factory setting)		N/A
	-	-		1		Display on the screen of PZ-61DR-E

\*Supply air temp. display flashes when 8°C or lower and 38°C or higher.

### 3.20 Temperature exchange efficiency setting

Set the tens digit of temperature exchange efficiency which is used to calculate supply air temperature.

DIP-SW		Setting check	PZ-61DR-E		Setting check	Tens digit of temperature exchange efficiency
SW No.	Setting		Function No.	Setting Data		
N/A	-	-	39	0		0
	-	-		1		1
	-	-		2		2
	-	-		3		3
	-	-		4		4
	-	-		5		5
	-	-		6		6
	-	-		7 (Factory setting)		7
	-	-		8		8
	-	-		9		9

Set the ones digit of temperature exchange efficiency which is used to calculate supply air temperature.

DIP-SW		Setting check	PZ-61DR-E		Setting check	Ones digit of temperature exchange efficiency
SW No.	Setting		Function No.	Setting Data		
N/A	-	-	40	0 (Factory setting)		0
	-	-		1		1
	-	-		2		2
	-	-		3		3
	-	-		4		4
	-	-		5		5
	-	-		6		6
	-	-		7		7
	-	-		8		8
	-	-		9		9

**Note;**

- Factory setting is 70%. 0~99% is selectable to set.
- For example, in the case that setting data of **No.39** is 8 and setting data of **No.40** is 5, the temperature exchange efficiency is 85%.

### 3.21 Outdoor temperature correction

Set the correction for the outdoor temperature displayed on the PZ-61DR-E screen by function **No.36**.

DIP-SW		Setting check	PZ-61DR-E		Setting check	The correction to thermistor detection	
SW No.	Setting		Function No.	Setting Data			
N/A	-	-	41	0		-7 °C	
	-	-		1		-6 °C	
	-	-		2		-5 °C	
	-	-		3		-4 °C	
	-	-		4		-3 °C	
	-	-		5		-2 °C	
	-	-		6		-1 °C	
	-	-		7	(Factory setting)		0 °C
	-	-		8			+1 °C
	-	-		9			+2 °C
	-	-		10			+3 °C
	-	-		11			+4 °C
	-	-		12			+5 °C
	-	-		13			+6 °C
-	-	14			+7 °C		

For example, in the case that setting data is 10, when the detected temp. is 20°C, the display temp. becomes 23°C.

**<Caution>**

- The temperature displayed on PZ-61DR-E is corrected, but the temperature used in the control software is not corrected.
- It is also necessary that "Temp. display" is selected as "Yes" on initial setting menu of PZ-61DR-E. Refer to the installation manual of PZ-61DR-E

### 3.22 Indoor temperature correction

Set the correction for the indoor temperature displayed on the PZ-61DR-E screen by function **No.37**.

DIP-SW		Setting check	PZ-61DR-E		Setting check	The correction to thermistor detection	
SW No.	Setting		Function No.	Setting Data			
N/A	-	-	42	0		-7 °C	
	-	-		1		-6 °C	
	-	-		2		-5 °C	
	-	-		3		-4 °C	
	-	-		4		-3 °C	
	-	-		5		-2 °C	
	-	-		6		-1 °C	
	-	-		7	(Factory setting)		0 °C
	-	-		8			+1 °C
	-	-		9			+2 °C
	-	-		10			+3 °C
	-	-		11			+4 °C
	-	-		12			+5 °C
	-	-		13			+6 °C
-	-	14			+7 °C		

For example, in the case that setting data is 10, when the detected temp is 20°C, the display temp. becomes 23°C.

**<Caution>**

- The temperature displayed on PZ-61DR-E is corrected, but the temperature used in the control software is not corrected.
- It is also necessary that "Temp. display" is selected as "Yes" on initial setting menu of PZ-61DR-E. Refer to the installation manual of PZ-61DR-E

### 3.23 Automatic ventilation mode setting

Refer to “Ventilation mode control” (C-43)

### 3.24 Automatic mode setting 1) Outdoor and indoor temperature difference

Refer to “Ventilation mode control” (C-44)

### 3.25 Automatic mode setting 2) The lowest outdoor temperature

Refer to “Ventilation mode control” (C-44)

### 3.26 Automatic mode setting 3) The lowest indoor temperature setting

Refer to “Ventilation mode control” (C-44)

### 3.27 Supply fan power up setting and Exhaust fan power up setting

Refer to “Fan speed control” (C-40)

### 3.28 Operation monitor output synchronized with exhaust fan or supply fan

Refer to “External input / output terminal” (C-52)

### 3.29 Bypass monitor output or Pre-heater output setting

Refer to “External input / output terminal” (C-51)

### 3.30 Pre-heater output setting 1) ON temperature

Refer to “Cautions of Lossnay operation in cold region” (C-48)

### 3.31 Pre-heater output setting 2) OFF interval

Refer to “Cautions of Lossnay operation in cold region” (C-49)

### 3.32 Fan speed for air volume “High” input

Refer to “Fan speed control” (C-40).

### 3.33 Fan speed for air volume “Low” input

Refer to “Fan speed control” (C-40).

### 3.34 External fan speed input setting (0 - 10 VDC)

Refer to “External input / output terminal” (C-54).

### 3.35 Initialization

Set to initialize the remote controller PZ-61DR-E function setting.  
All function settings which are changed by users are cancelled.

DIP-SW		Setting check	PZ-61DR-E		Setting check	Initialization
SW No.	Setting		Function No.	Setting Data		
N/A	-	-	100	0		N/A
	-	-		1		Available

## 4. Fan speed control

### 4.1 Fan speed control for each system

Following controls can be performed according to system configuration.

System		Remote controllers System controllers	Air volume
Basic System	Stand-alone/multiple Lossnay and Lossnay remote controller: PZ-61DR-E	Lossnay remote controller PZ-61DR-E	Fan speed 4 / 3 / 2 / 1 are selectable by the "Fan" button of the remote controller.
	Stand-alone/multiple Lossnay and Lossnay remote controller: PZ-43SMF-E	Lossnay remote controller PZ-43SMF-E	Fan speed High / Low are selectable by "Fan speed" button of the remote controller.
	System interlocked with Mr.Slim	MA remote controller PAR-31MAA (Remote controller connection prohibited with Lossnay)	Fan speed High / Low are selectable by ventilation operation of the remote controller.
	Level signal/pulse signal output device and external device only	None	Fixed to fan speed 4
M-NET Control	Stand-alone/multiple Lossnay and Lossnay remote controller: PZ-61DR-E	Lossnay remote controller PZ-61DR-E	Fan speed 4 / 3 / 2 / 1 are selectable by the "Fan" button of the remote controller
	Stand-alone/multiple Lossnay and Lossnay remote controller: PZ-43SMF-E	Lossnay remote controller PZ-43SMF-E	Fan speed High / Low are selectable by "Fan speed" button of the remote controller.
	M-NET Lossnay central control system	M-NET controller	Selectable fan speed depends on the remote controller.
	M-NET System interlocked with City Multi indoor units	Smart ME Controller PAR-U02MEDA MA remote controller PAR-31MAA	Fan speed High / Low are selectable by ventilation operation of the remote controller.

### 4.2 Fan speed control by function settings

Fan speed controls listed below can be set by function setting of remote controller PZ-61DR-E or DIP-SW 2, 5.

#### 4.2.1 Indoor negative pressure setting

Exhaust fan speed is bigger than supply fan speed.  
Remote controller indicates fan speed of exhaust fan.

Fan speed Display	Exhaust fan	Supply fan	
		1 down	2 down
4	4	3	2
3	3	2	1
2	2	1	1
1	1	1	1

DIP-SW		Setting check	PZ-61DR-E		Setting check	Down level of supply fan speed
SW No.	Setting		Function No.	Setting Data		
SW2-4	-	-	6	0 (Factory setting)		DIP-SW priority
	OFF (Factory setting)			1		N/A
	ON			2		Supply fan speed is 1 down to exhaust fan speed
	-	-		3		Supply fan speed is 2 down to exhaust fan speed

**Note;**

- In the case of multiple Lossnay units and PZ-61DR-E, setting from PZ-61DR-E is available only when Lossnay units have individual address.

**4.2.2 Indoor positive pressure setting**

Supply fan speed is bigger than exhaust fan speed.  
Remote controller indicates fan speed of supply fan.

Fan speed Display	Supply fan	Exhaust fan	
		1 down	2 down
4	4	3	2
3	3	2	1
2	2	1	1
1	1	1	1

DIP-SW			PZ-61DR-E		Setting check	Down level of exhaust fan speed
SW No.	Setting	Setting check	Function No.	Setting Data		
SW2-5	-	-	7	0 (Factory setting)		DIP-SW priority
	OFF (Factory setting)			1		N/A
	ON			2		Exhaust fan speed is 1 down to supply fan speed
	-	-		3		Exhaust fan speed is 2 down to supply fan speed

**Note;**

- In the case of multiple Lossnay units and PZ-61DR-E, setting from PZ-61DR-E is available only when Lossnay units have individual address.

**4.2.3 Max. fan speed setting during the first 30 minutes**

This sets the fan to run forcibly for 30 minutes when operation starts to ventilate the indoor area. After 30 minutes, fan speed can be changed.

Use this setting if the indoor air is contaminated at night when the system is shut down and you desire to ventilate the indoor area quickly when operation is started in the morning.

When this function is working,  is displayed on PZ-61DR-E and selected fan speed is displayed.

DIP-SW			PZ-61DR-E		Setting check	Max. fan speed setting during the first 30 minutes
SW No.	Setting	Setting check	Function No.	Setting Data		
N/A	-	-	8	0 (Factory setting)		N/A
	-	-		1		Available

**4.2.4 Delay start setting for air conditioner starting**

Delays Lossnay operation for 15 or 30 minutes when City Multi or Mr. Slim starts operating or when a external device starts operating.

This function is not available during Night-purge or with pulse input setting.

When this function is working,  is displayed on PZ-61DR-E and "AFTER 00:30 Hr ON" is displayed on PZ-43SMF-E.

When not using Lossnay remote controller, it is possible to check the delay duration by seeing the LED1 on PCB.

When the interval from the last Lossnay operation is 2hrs or less, Lossnay ignores this function.

DIP-SW			PZ-61DR-E		Setting check	Lossnay delay start
SW No.	Setting	Setting check	Function No.	Setting Data		
SW5-1	-	-	9	0 (Factory setting)		DIP-SW priority
	OFF (Factory setting)			1		N/A
	-	-		2		15 min
	ON			3		30 min

**(1)Initiation condition**

This function is available when MITSUBISHI air conditioner starts at cooling (drying) or heating mode or non-MITSUBISHI air conditioner starts.

**(2)Usage example**

Following example shows the conditions when interlocked with City Multi (delay time is set to 30min).

- City Multi starts heating operation at 8:00. In order to enhance heating effectiveness, Lossnay starts 30 min. later.
- Both City Multi and Lossnay is stopped during 12:00 to 13:00 due to lunch break.

When City Multi turns ON again at 13:00, Lossnay start operation immediately.

Time	8:00	8:30	12:00	13:00	17:00
City Multi	OFF	Heating	OFF	Heating	OFF
Lossnay	OFF	ON	OFF	ON	OFF

★ Delay start function does not be activate, because the interval is less than 2 hours.

**4.2.5 Exhaust fan setting during air conditioner defrosting or at OA temperature lower than -15 °C**

When the Lossnay unit is interlocked with Mr.Slim or City Multi indoor units and supply duct of Lossnay is connected to the indoor unit, the supply fan of the Lossnay unit will be forced to stop during air conditioner defrosting or stopping by error.

This function is to set the operation of the exhaust fan during defrosting of the air conditioner.

To enable this function, it is necessary to set the DIP-SW of the indoor unit also. Please refer to its manual.

DIP-SW		Setting check	PZ-61DR-E		Setting check	Exhaust fan operation during air conditioner defrosting
SW No.	Setting		Function No.	Setting Data		
SW5-3	-	-	13	0 (Factory setting)		DIP-SW priority
	ON			1		Stop
	OFF (Factory setting)			2		No change

Set the operation of the exhaust fan when the outdoor air is lower than -15 °C (when supply fan stop).

DIP-SW		Setting check	PZ-61DR-E		Setting check	Exhaust fan operation at outdoor temp. -15 °C or less
SW No.	Setting		Function No.	Setting Data		
SW5-3 SW5-9	-	-	14	0 (Factory setting)		DIP-SW priority
	5-3 OFF 5-9 ON			1		Stop
	5-3 ON 5-9 OFF			2		Forced to fan speed 2 or less*
	5-3 OFF 5-9 OFF (Factory setting)			3		No change
	5-3 ON 5-9 ON					

\* In case Lossnay is operating at fan speed 1, exhaust fan keeps fan speed 1.

Function **No.13** and **No.14** are included in DIP-SW 5-3, then it is impossible to set independently without PZ-61DR-E.

**4.2.6 Supply fan power up setting / Exhaust fan power up setting**

Use these functions when the air volume needs to be increased after installation.  
 Function **No.55** is for supply fan power up and function **No.56** is for exhaust fan power up.  
 When function **No.1** is ON and fan speed already reached the maximum power, this function is N/A.  
 The air volume at "4 level up" is increased by about 5-10% from the original.

DIP-SW		Setting check	PZ-61DR-E		Setting check	Supply fan power up
SW No.	Setting		Function No.	Setting Data		
N/A	-	-	55	0 (Factory setting)		N/A
	-	-		1		1 level up
	-	-		2		2 level up
	-	-		3		3 level up
	-	-		4		4 level up

DIP-SW		Setting check	PZ-61DR-E		Setting check	Exhaust fan power up
SW No.	Setting		Function No.	Setting Data		
N/A	-	-	56	0 (Factory setting)		N/A
	-	-		1		1 level up
	-	-		2		2 level up
	-	-		3		3 level up
	-	-		4		4 level up

**4.2.7 Fan speed for air volume “High” input**

Set the fan speed setting when receiving “High” signal from remote controllers (e.g. remote controller of City Multi and Mr. Slim, PZ-43SMF-E) that have High/Low or High/Middle/Low air volume.

DIP-SW		Setting check	PZ-61DR-E		Setting check	Operating fan speed
SW No.	Setting		Function No.	Setting Data		
SW2-9	-	-	61	0 (Factory setting)		DIP-SW priority
	OFF (Factory setting)			1		Fan speed 4
	ON			2		Fan speed 3

**<Caution>**

- In the case of multiple Lossnay units system, all Lossnay should be the same setting.

**4.2.8 Fan speed for air volume “Low” input**

Set the fan speed setting when receiving “Low” signal from remote controllers (e.g. remote controller of City Multi and Mr. Slim, PZ-43SMF-E) that have High/Low.

DIP-SW		Setting check	PZ-61DR-E		Setting check	Operating fan speed
SW No.	Setting		Function No.	Setting Data		
SW2-10	-	-	62	0 (Factory setting)		DIP-SW priority
	OFF (Factory setting)			1		Fan speed 2
	ON			2		Fan speed 1

**<Caution>**

- In the case of multiple Lossnay units system, all Lossnay should be the same setting.

**4.2.9 External fan speed input setting (0-10VDC)**

Refer to page C-54



## 5. Ventilation mode control

### 5.1 Effect of Bypass Ventilation

The automatic mode provides the correct ventilation for the room conditions. It eliminates the need for troublesome switch operations when setting the Lossnay to Bypass mode. The following shows the effect of Bypass mode.

#### 1. Reduces cooling load

If the air outside is cooler than the air inside the building during the cooling season (such as early morning or night), Bypass mode will intake the cooler outside air without energy recovery and reduce the cooling load of air conditioner.

#### 2. Free cooling

Bypass mode can be used to cool inside the building with cooler outside air in the season when cooling load is not so big like spring or autumn.

#### 3. Night-purge

Bypass ventilation can be used to release any accumulated hot air from inside the building during the hot summer season.

#### 4. Office equipment room cooling

During cold season, outdoor air can be drawn in and used as is to cool rooms where the temperature has risen due to office equipment use. (Only when interlocked with City Multi and Mr. Slim indoor unit)

### 5.2 Ventilation mode

There are 3 ventilation modes.

1	Energy recovery mode	Energy recovery mode is performed regularly via the Lossnay core.
2	Bypass (non-energy recovery) mode	Ventilation is performed regularly without going through the Lossnay core.
3	Automatic mode	A temperature sensor built into the unit provides automatic ventilation to a suitable ventilation mode. In addition, energy saving ventilation is provided by interlocking with a Mr. Slim or City Multi indoor unit.

- Maximum 30 sec. delay exists from button operation or external input to the start of damper operation.

#### <Caution>

The fan motor stops approx. 20 sec. prior to the damper operation for switching ventilation mode.

### 5.3 Prohibition conditions of Bypass mode during Bypass mode operation

When the conditions described below are applicable, the ventilation mode will be changed to energy recovery mode. The RC display keeps "↔" indicator even when actual operation is energy recovery.

- When the outdoor temperature is 8°C or lower. (Product condensation prevention)
- When there is an outdoor temperature (Outdoor Air) thermistor fault.
- When pre-heater is ON and for one hour after that pre-heater becomes OFF.
- When City Multi or Mr. Slim indoor unit which is interlocked with Lossnay is defrosting.

## 5.4 Ventilation mode control for each system

Following controls can be performed according to system configuration.

System		Remote controllers System controllers	Ventilation mode
Basic System	Stand-alone/multiple Lossnay and Lossnay remote controller: PZ-61DR-E	Lossnay remote controller PZ-61DR-E	The "Mode" button of the remote controller permits ventilation mode switching for automatic, energy recovery and Bypass mode. Bypass mode is set at the time of Night-purge operation, and mode switching is not possible.
	Stand-alone/multiple Lossnay and Lossnay remote controller: PZ-43SMF-E	Lossnay remote controller PZ-43SMF-E	The "Ventilation mode" button of the remote controller permits mode switching for automatic, energy recovery, and Bypass mode.
	System interlocked with Mr.Slim	MA remote controller PAR-31MAA (Remote controller connection prohibited with Lossnay)	Fixed to automatic mode.
	Level signal/pulse signal output device and external device only	None	Fixed to automatic mode.
M-NET Control	Stand-alone/multiple Lossnay and Lossnay remote controller: PZ-61DR-E	Lossnay remote controller PZ-61DR-E	The "Mode" button of the remote controller permits ventilation mode switching for automatic, energy recovery and Bypass mode. Bypass mode is set at the time of Night-purge operation, and mode switching is not possible.
	Stand-alone/multiple Lossnay and Lossnay remote controller: PZ-43SMF-E	Lossnay remote controller PZ-43SMF-E	The "Ventilation mode" button of the remote controller permits ventilation mode switching for automatic, energy recovery, and Bypass mode.
	M-NET Lossnay central control system	M-NET controller	The "Operation mode" button of the system remote controller and the centralized controller permits ventilation mode switching for automatic, energy recovery, and Bypass mode. (The schedule timer, ON/OFF remote controller, and the group remote controller do not permit ventilation mode selection.)
	M-NET System interlocked with City Multi indoor units	Smart ME Controller PAR-U02MEDA MA remote controller PAR-31MAA	Fixed to automatic mode.

## 5.5 Automatic mode algorithm temperature map

In automatic mode, energy recovery mode and Bypass mode switches in accordance with room temp. (RA) and outdoor temp. (OA).

### 5.5.1 Prohibition conditions of Bypass mode during automatic mode operation

When the conditions described below are applicable, the ventilation mode will be fixed at energy recovery mode.

- When the outdoor temperature is 8°C or lower. (Product condensation prevention)
- When Lossnay, interlocked with Mr.Slim or City Multi indoor unit, is set to the automatic mode and A/C is operating at the fan operation mode or heating mode.
- When there is an outdoor temperature (Outdoor Air) thermistor fault.
- When there is a room temperature (Return Air) thermistor fault.

### 5.5.2 Automatic mode [Pattern A, Pattern B, Free setting]

LGH-RVX-E decides Bypass mode or energy recovery mode by the temperature of OA and RA every 30 minutes. Set the pattern of conditions to go into Bypass mode in automatic mode from Pattern A, Pattern B or Free setting by the following table. Pattern A is more likely to go into Bypass mode than Pattern B.

When setting data of function **No.51** is set "3" by PZ-61DR-E, function **No.52**, **No.53**, and **No.54** are available.

#### **No.51** Automatic mode setting

DIP-SW		Setting check	PZ-61DR-E		Setting check	Automatic mode
SW No.	Setting		Function No.	Setting Data		
SW2-7	-	-	51	0 (Factory setting)		DIP-SW priority
	OFF (Factory setting)			1		Pattern A Indoor temperature is 16 °C or more Outdoor temperature is 16 °C or more Indoor temperature - outdoor temperature ≥ 0K
	ON			2		Pattern B Indoor temperature is 22 °C or more Outdoor temperature is 18 °C or more Indoor temperature - outdoor temperature ≥ 2K
	-	-		3		Free setting

Pre-defined Pattern A and B are the following maps.

By using "Free setting", it is possible to make a free Bypass ventilation area like following examples.

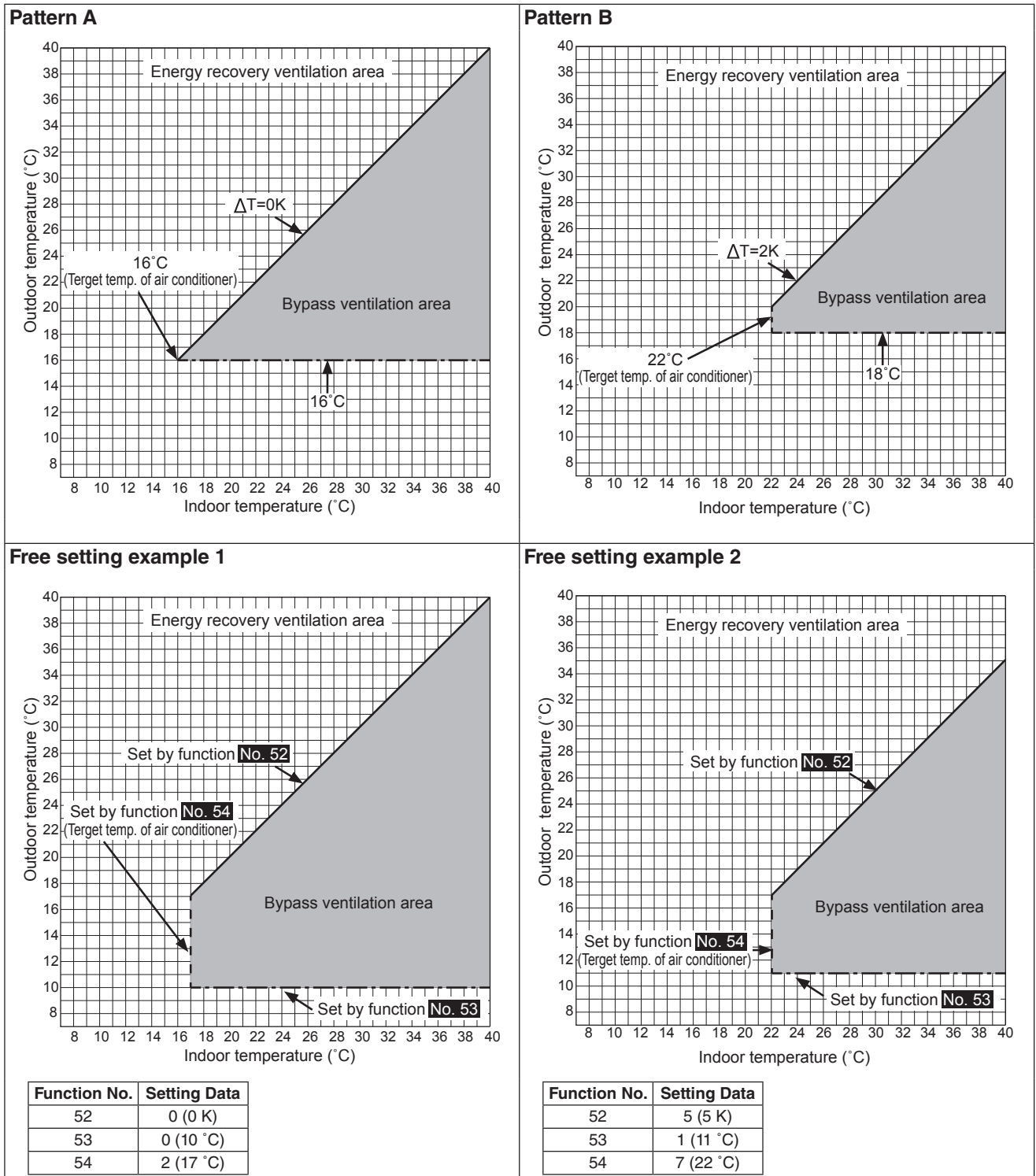

**Note;**

- When Lossnay is interlocked to Mr. Slim or City Multi indoor unit, the lowest indoor temperature for Bypass mode is the average target temperature of indoor units.

**5.5.3 How to set Free setting from PZ-61DR-E**

The details of function **No.52** to **No.54** are as followings

**No.52 Automatic mode setting 1) Outdoor and indoor temperature difference**

DIP-SW			PZ-61DR-E		Setting check	Indoor temperature - outdoor temperature
SW No.	Setting	Setting check	Function No.	Setting Data		
N/A	-	-	52	0 (Factory setting)		0 K or more
	-	-		1		1 K or more
	-	-		2		2 K or more
	-	-		3		3 K or more
	-	-		4		4 K or more
	-	-		5		5 K or more
	-	-		6		6 K or more
-	-	7		7 K or more		

**No.53 Automatic mode setting 2) The lowest outdoor temperature**

DIP-SW			PZ-61DR-E		Setting check	Outdoor temperature
SW No.	Setting	Setting check	Function No.	Setting Data		
N/A	-	-	53	0		10 °C or more
	-	-		1		11 °C or more
	-	-		2		12 °C or more
	-	-		3		13 °C or more
	-	-		4		14 °C or more
	-	-		5		15 °C or more
	-	-		6 (Factory setting)		16 °C or more
	-	-		7		17 °C or more
	-	-		8		18 °C or more
	-	-		9		19 °C or more
	-	-		10		20 °C or more
	-	-		11		21 °C or more
	-	-		12		22 °C or more
	-	-		13		23 °C or more
	-	-		14		24 °C or more
-	-	15		25 °C or more		

**No.54 Automatic mode setting 3) The lowest indoor temperature setting**

When Lossnay is interlocked to Mr. Slim or City Multi indoor unit, the lowest indoor temperature for Bypass mode is the average target temperature of indoor units.

DIP-SW			PZ-61DR-E		Setting check	Indoor temperature
SW No.	Setting	Setting check	Function No.	Setting Data		
N/A	-	-	54	0		15 °C or more
	-	-		1 (Factory setting)		16 °C or more
	-	-		2		17 °C or more
	-	-		3		18 °C or more
	-	-		4		19 °C or more
	-	-		5		20 °C or more
	-	-		6		21 °C or more
	-	-		7		22 °C or more
	-	-		8		23 °C or more
	-	-		9		24 °C or more
	-	-		10		25 °C or more
	-	-		11		26 °C or more
	-	-		12		27 °C or more
	-	-		13		28 °C or more
	-	-		14		29 °C or more
-	-	15		30 °C or more		

**Note;**

- This "Free setting" function is available only when Lossnay is used with PZ-61DR-E and is N/A from Lossnay unit DIP-SW.
- When the setting of Function **No.53** is low, and using with pre-heater, the outdoor temperature may be detected as higher and the mode may change to Bypass mode even in winter. Set the setting 16°C or more, or use energy recovery mode.

## 6. Night-purge function

### 6.1 Descriptions of Night-purge function.

During the summer season, the Night-purge mode draws cooler outside air into the room at night. This energy conservation mode reduces the starting load of the air conditioner the next morning.

PZ-61DR-E or centralized controller is necessary for Night-purge function.

 appears on the PZ-61DR-E when the Night-purge function is available.

It is possible to freely set the Night-purge operation for the start conditions, fan speed, and operation time. (Settings can be made by PZ-61DR-E or AE-200E (Ver.7.30~))

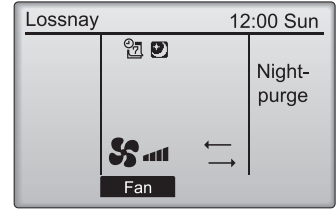

#### <Night-purge starting condition>

No.	Content
1	Lossnay is OFF
2	The time display is between operation starting time and end time. *1
3	Summer condition judgement (correspond to any of the following) <ul style="list-style-type: none"> <li>• Outdoor temperature was detected more than 17°C within 24 hours. *2</li> <li>• The Lossnay unit is interlocked with City Multi and operation mode of indoor unit was “cool” or “dry”.</li> </ul>
4	Indoor temperature is higher than 22°C
5	Indoor temperature is 5K higher than outdoor temperature. *3

\*1 Night-purge starting time and ending time are settable by a controller. Refer to “How to set Night-purge from the remote controller”(C-47). (for PZ-61DR-E)

\*2 The threshold of outdoor temperature can be set to between 15°C and 30°C (1K increments). Factory setting is 17°C. If the maximum outdoor temperature in the last 24 hours exceeded this temperature value (threshold), Lossnay starts the temperature monitoring operation. By setting the lower threshold, Lossnay is more likely to start Night-purge operation. Refer to “Night-purge setting 3) Threshold of outdoor temperature” (C-47) (for PZ-61DR-E)

\*3 Outdoor and indoor temperature difference can be set to between 0K and 7K (1K increments). Factory setting is 5K Refer to Night-purge setting 2) Outdoor and indoor temperature difference”(C-47) (for PZ-61DR-E)

\*4 Fan speed during Night-purge must be set.

\*5 Outdoor and indoor temperature are sensed by Lossnay unit. Those are different from actual outdoor / indoor temperature

- When time display is equal to Night-purge starting time, if starting condition No.1 and No.3 are satisfied, temperature monitor operation starts for 5 minutes to detect outdoor and indoor temperature. If not, the unit stops.

- The unit stops if starting condition No.2, No.4 and No.5 aren't satisfied during Night-purge operation.

- If starting condition No.4 and No.5 are not satisfied during Night-purge active time, the unit perform temperature monitoring operation for 5 minutes every 1 hour. If starting condition No.2 and No.3 are satisfied after that monitoring operation, Night-purge operation will start. If not, the unit will stop.

- If Lossnay unit is turned ON by controller button, Night-purge will not operate until next time.

#### Note;

- Fan speed can be selected by function setting, but cannot be selected in the Weekly timer. If you change fan speed during Night-purge by the remote controller (PZ-61DR-E), Lossnay follows it.
- If the Night-purge function is not enabled, Lossnay will not operate it properly even if it is set in the Weekly timer.
- Night-purge operation is always Bypass mode so that if the temperature conditions and others are the prohibition conditions of Bypass mode (5.5.1, page C-42), Night-purge operation does not start.
- If ventilation mode is switched by system controller during Night-purge operation, Lossnay will end the Night-purge and continue to operate normally.

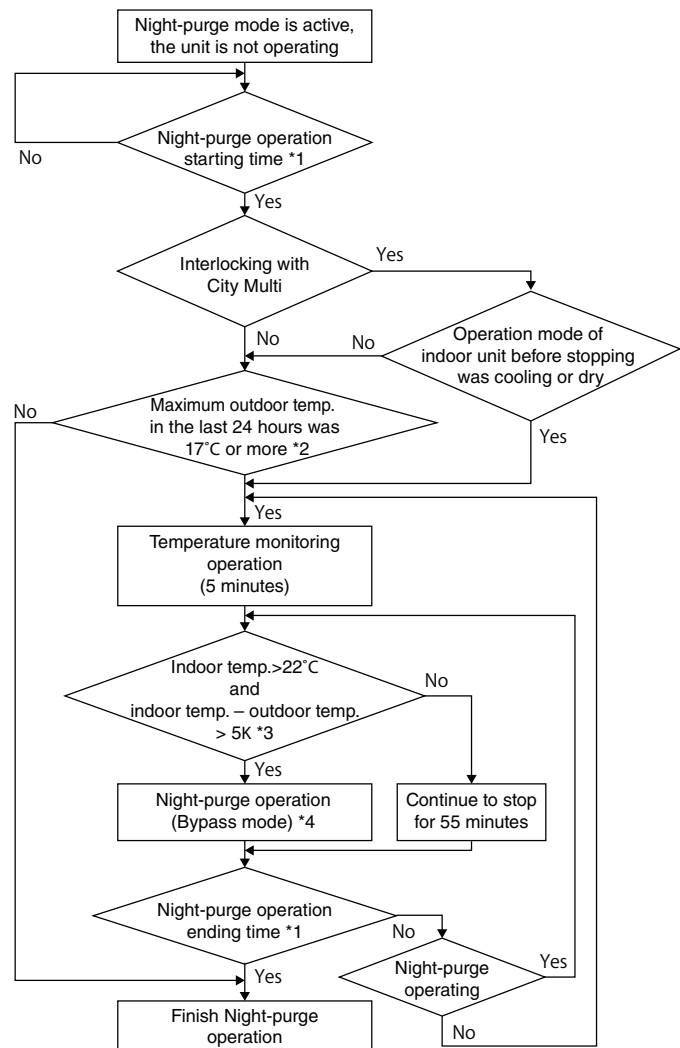

## CHAPTER 2 Function / 6. Night-purge function

For more details about settable functions by each controller, see the below tables.

	PZ-61DR-E alone	PZ-61DR-E + AG-150A or AE-200E (~ Ver. 7.11)	PZ-61DR-E + AE-200E (Ver. 7.20) *6	PZ-61DR-E + AE-200E (Ver. 7.30 ~) *6	AG-150A or AE-200E (~ Ver. 7.11) alone	AE-200E (Ver. 7.20) alone	AE-200E (Ver. 7.30 ~) alone
Setting Night-purge starting / ending time	○	△ (Fixed to 1:00-6:00)	○	○	Night-purge Not Available	○	○
Setting fan speed during Night-purge	○	×	△ (Fan speed 1, 2 and 3 or 4)	○		△ (Fan speed 1, 2 and 3 or 4)	○
Setting the threshold of outdoor temperature to start Night-purge	○	×	○	○		○	○
Setting outdoor and indoor temperature difference condition	○	×	○	○		○	○

\*6 When using PZ-61DR-E and AE-200E ( Ver. 7.20 ~ ) together, set all conditions from AE-200E.

• This information is based on the schedule at Jan. 2015. Please confirm to the latest AE-200E manuals.

### <Night-purge time chart>

- This example shows when Night-purge function is active, starting condition No.2 and No.5 are factory setting and timer is set as follows.  
20:00 Off ; (next day) 1:00 Night-purge start ; 6:00 Off
- When time is 1:00 and 2:00, Night-purge operation does not start because the difference between indoor and outdoor temperature is less than 5K.
- When time is 3:00, Lossnay start Night-purge operation because the difference between indoor and outdoor temperature exceeds 5K.

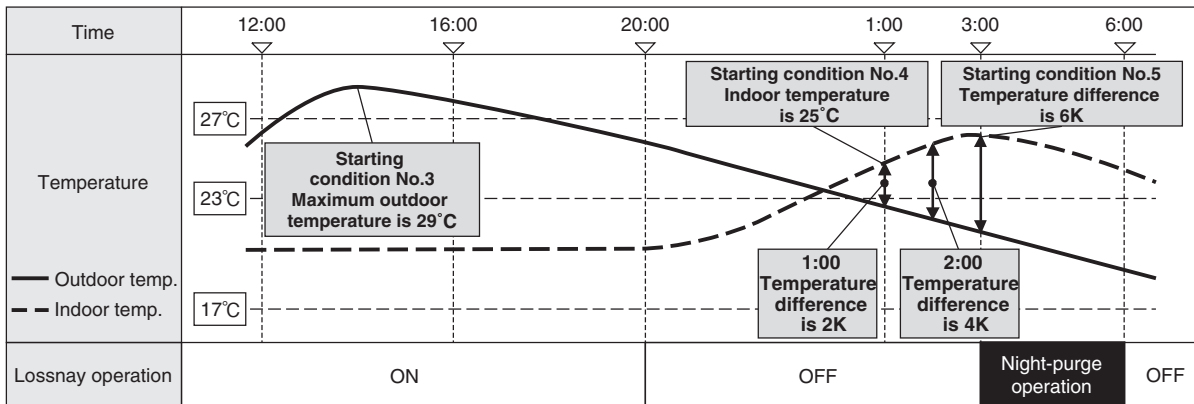

This graph is only an illustration, not an actual representation

## 6.2 How to set Night-purge from the remote controller (PZ-61DR-E)

### <STEP 1> Night-purge setting 1) Air volume

Set fan speed during Night-purge.  
When setting data is "0", Night-purge function is not available.  
This function is N/A from Lossnay unit DIP-SW.

DIP-SW		Setting check	PZ-61DR-E		Setting check	Air volume
SW No.	Setting		Function No.	Setting Data		
N/A	-	-	30	0 (Factory setting)		N/A (Night-purge function is not available)
	-	-		1		Fan speed 1
	-	-		2		Fan speed 2
	-	-		3		Fan speed 3
	-	-		4		Fan speed 4

### <STEP 2> Night-purge setting 2) Outdoor and indoor temperature difference

Set one of the conditions for Night-purge start, temperature difference between indoor and outdoor.  
When the actual difference between indoor and outdoor becomes bigger than the setting, Night-purge starts.  
This function is N/A from Lossnay unit DIP-SW.

DIP-SW		Setting check	PZ-61DR-E		Setting check	Indoor temperature - outdoor temperature
SW No.	Setting		Function No.	Setting Data		
N/A	-	-	31	0		0 K or more
	-	-		1		1 K or more
	-	-		2		2 K or more
	-	-		3		3 K or more
	-	-		4		4 K or more
	-	-		5 (Factory setting)		5 K or more
	-	-		6		6 K or more
	-	-		7		7 K or more

### <STEP 3> Night-purge setting 3) Threshold of outdoor temperature

Set one of the conditions for Night-purge start, maximum outdoor temperature within 24 hours.  
When this setting temperature is low, it is likely to start Night-purge.  
This function is N/A from Lossnay unit DIP-SW.

DIP-SW		Setting check	PZ-61DR-E		Setting check	Threshold of outdoor temperature
SW No.	Setting		Function No.	Setting Data		
N/A	-	-	32	0		15 °C or more
	-	-		1		16 °C or more
	-	-		2 (Factory setting)		17 °C or more
	-	-		3		18 °C or more
	-	-		4		19 °C or more
	-	-		5		20 °C or more
	-	-		6		21 °C or more
	-	-		7		22 °C or more
	-	-		8		23 °C or more
	-	-		9		24 °C or more
	-	-		10		25 °C or more
	-	-		11		26 °C or more
	-	-		12		27 °C or more
	-	-		13		28 °C or more
	-	-		14		29 °C or more
-	-	15		30 °C or more		

### <STEP 4> Night-purge schedule setting

Set the "Night-purge schedule" after "Off schedule" like the example on the right (upper).  
Off setting is necessary before Night-purge setting.  
If not, Night-purge does not start.

For example, the setting as shown on the right (lower) is NOT correct.  
Night-purge operation continues until next "Off schedule" or "On schedule" time which is set in the weekly timer.  
Then be sure to set "Off schedule" or "On schedule" after "Night-purge schedule".  
\*If there is no schedule after a Night-purge, Lossnay will stop after 24 hours of Night-purge operation.

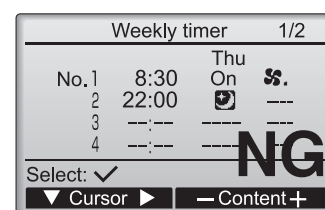
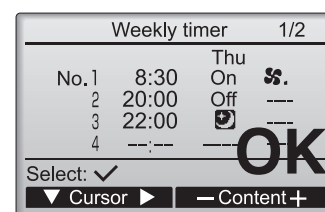

#### Note;

How to set Night-purge from the centralized controller (AE-200E, ver. 7.30 or later), refer to the manual of the centralized controller.

## 7. Cautions of Lossnay Operation in cold region

### 7.1 Intermittent operation in cold region

In the event of the following, continuous fan operation for drawing in supply air is cancelled and intermittent operation starts.

-10°C to -15°C : Intermittent operation 60 min ON, 10 min OFF.

-15°C or less : Intermittent operation 55 min OFF, 5 min ON. This is sensing operation for OA temp.

The  icon is displayed on PZ-61DR-E when the supply fan is stopping.

### 7.2 Pre-heater control from Lossnay

Lossnay can output a signal to a pre-heater.

#### <Output setting>

- Pre-heater output can be set at function setting **No.58** or DIP-SW5-6. (refer to page C-51)

#### <Output condition>

- Pre-heater output basically corresponds with supply fan operation, but 10 sec. delay exists at the start.
- When pre-heater output is set, supply fan continues operation for 3 min. extra for cooling down after OFF button pushed or OFF signal input.
- Pre-heater output starts when OA temp. becomes lower than the threshold temp. selectable between -7°C and 0°C. (C-48)
- Pre-heater output stops when OA temp. becomes higher than 15°C.
- Pre-heater output stops 1~5 hours after output start. The interval is selectable between 1 hour and 5 hours. (C-49)
- Note; When pre-heater output is activated, low temperature intermittent operation is not available.

#### <Error>

- Error code is displayed on the monitor and malfunction monitor is output in the following cases.
  - 1) OA thermistor detects higher than 15°C within 15 minutes after the output starts.
  - 2) OA thermistor detects -10°C or lower, 60 minutes after the output starts.

#### 7.2.1 Pre-heater output setting 1) ON temperature

DIP-SW		Setting check	PZ-61DR-E		Setting check	Outdoor temp. for Preheater output ON
SW No.	Setting		Function No.	Setting Data		
N/A	-	-	59	0 (Factory setting)		0 °C or less
	-	-		1		-1 °C or less
	-	-		2		-2 °C or less
	-	-		3		-3 °C or less
	-	-		4		-4 °C or less
	-	-		5		-5 °C or less
	-	-		6		-6 °C or less
	-	-		7		-7 °C or less



**7.2.2 Pre-heater output setting 2) OFF interval**

DIP-SW		Setting check	PZ-61DR-E		Setting check	Pre-heater output OFF interval
SW No.	Setting		Function No.	Setting Data		
N/A	-	-	60	0 (Factory setting)		1hr
	-	-		1		2hrs
	-	-		2		3hrs
	-	-		3		4hrs
	-	-		4		5hrs

**7.2.3 Wiring**

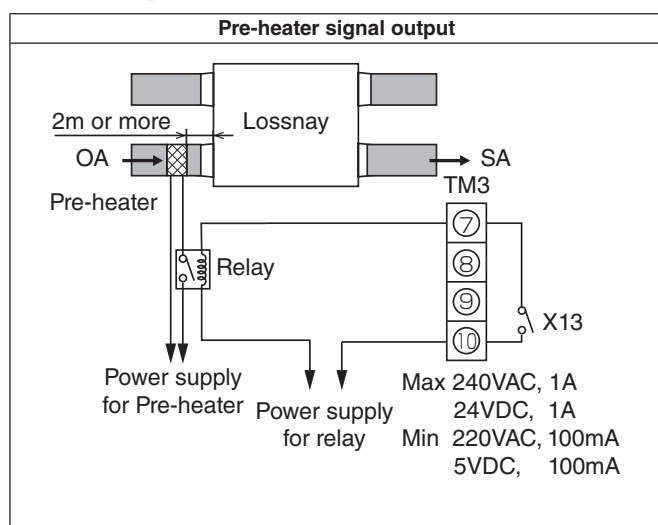

**7.2.4 Cautions of selecting a pre-heater**

- Select a duct heater in compliance with local and national laws, ordinances, and standards. Select a duct heater that has obtained the CE mark.
- Always select a heater that is equipped with a non-self-resetting safety device. Do not directly supply power from the Lossnay unit to the duct heater. (Doing so could cause fire.)
- Install a circuit breaker for the duct heater in compliance with all applicable laws, ordinances, and standards.
- Install the duct heater separated from the product by a distance of 2 m or more. (Failure to do so may result in equipment damage due to the transmission of residual heat from the heater.)
- When using a heater without a temperature control function, select a heater with a capacity that is matched to the air volume.
- Do not use the heater outside the set air volume. (If the heater's capacity is too large, this may result in the heater frequently turning ON/OFF.) (If the heater's capacity is too small, this may result in an inability to heat.)
- Ensure that the duct heater and Lossnay are wired and that the Lossnay function settings have been configured, and then always check operation by trial operation.
- When set to automatic mode while using the pre-heater function, the outdoor temperature may be detected as higher and the mode may change to Bypass mode, even in winter.
- When the pre-heater is ON, Lossnay does not go to fan speed 1. Even remote controller displays fan speed 1, Lossnay is operated at fan speed 2.
- When the Lossnay unit has duct connections and is interlocked with Mr. Slim or City Multi indoor units, the supply fan and pre-heater output stop during air conditioner defrosting.

**7.2.5 Reference of heater capacity**

Heater capacity can be calculated by the following formula.

$$W1 = Sf \times Q \times \gamma \times C \times (Toa2-Toa1) \div 3600$$

$$= 1.0 \times Q \times 1.2 \times 1.0 \times (Toa2-Toa1) \div 3600 \text{ [kW]} \dots\dots\dots \textcircled{1}$$

Q [m<sup>3</sup>/h] : Air volume

γ [kg/m<sup>3</sup>] : Specific air density, 1.2

C [kJ/kg] : Specific heat of air, 1.0

Toa1 [°C] : Primary temp.

Toa2 [°C] : Secondly temp.

Sf : Safety ratio, 1.0 ..... Safety ratio is 1.0 to prevent selecting too big capacity.



Quick reference for heater capacity calculation for each model.

When heater capacity is calculated with fan speed 2

[kW]

Model		LGH-15RVX-E	LGH-25RVX-E	LGH-35RVX-E	LGH-50RVX-E	LGH-65RVX-E	LGH-80RVX-E	LGH-100RVX-E	LGH-150RVX-E	LGH-200RVX-E
Air flow rate m <sup>3</sup> /h		75	125	175	250	325	400	500	750	1000
Heater capacity	Target OA temp. increase 5K	0.13	0.21	0.29	0.42	0.54	0.67	0.83	1.25	1.67
	Target OA temp. increase 10K	0.25	0.42	0.58	0.83	1.08	1.33	1.67	2.50	3.33

When heater capacity is calculated with fan speed 3

[kW]

Model		LGH-15RVX-E	LGH-25RVX-E	LGH-35RVX-E	LGH-50RVX-E	LGH-65RVX-E	LGH-80RVX-E	LGH-100RVX-E	LGH-150RVX-E	LGH-200RVX-E
Air flow rate m <sup>3</sup> /h		113	188	263	375	488	600	750	1125	1500
Heater capacity	Target OA temp. increase 5K	0.19	0.31	0.44	0.63	0.81	1.00	1.25	1.88	2.50
	Target OA temp. increase 10K	0.38	0.63	0.88	1.25	1.63	2.00	2.50	3.75	5.00

When heater capacity is calculated with fan speed 4

[kW]

Model		LGH-15RVX-E	LGH-25RVX-E	LGH-35RVX-E	LGH-50RVX-E	LGH-65RVX-E	LGH-80RVX-E	LGH-100RVX-E	LGH-150RVX-E	LGH-200RVX-E
Air flow rate m <sup>3</sup> /h		150	250	350	500	650	800	1000	1500	2000
Heater capacity	Target OA temp. increase 5K	0.25	0.42	0.58	0.83	1.08	1.33	1.67	2.50	3.33
	Target OA temp. increase 10K	0.50	0.83	1.17	1.67	2.17	2.67	3.33	5.00	6.67

## 8. External Input/output terminal

There are terminals and connectors on the PCB to output operating conditions of Lossnay to an external device and to receive signals to switch ON/OFF, fan speed and ventilation mode from an external device.

### 8.1 Output terminal

Output	Terminal block	Signal form	Contact rating	
			Maximum	Minimum
Bypass monitor or pre-heater signal output	TM3(7)(10)	Volt-free contact signal	240 VAC, 1A 24 VDC, 1A	220 VAC, 100mA 5 VDC, 100mA
Malfunction monitor output	TM3(8)(10)			
Operation monitor output	TM3(9)(10)			

\*TM3 (10) is common terminal for each output.

#### 8.1.1 Bypass monitor output or pre-heater output setting

Bypass monitor or pre-heater signal can be selected at DIP-SW5-6 or PZ-61DR-E

Always check that it is the intended setting.

Set Bypass monitor or pre-heater output from TM3(7)(10) synchronized with supply of exhaust fan.

DIP-SW		Setting check	PZ-61DR-E		Setting check	Output setting from TM3(7)(10)
SW No.	Setting		Function No.	Setting Data		
SW5-6	-	-	58	0 (Factory setting)		DIP-SW priority
	OFF (Factory setting)			1		Bypass monitor output. Corresponds to operation mode output of Bypass damper.
	ON			2		Pre-heater signal output Refer to 7.2 (C-48)

#### <Wiring>

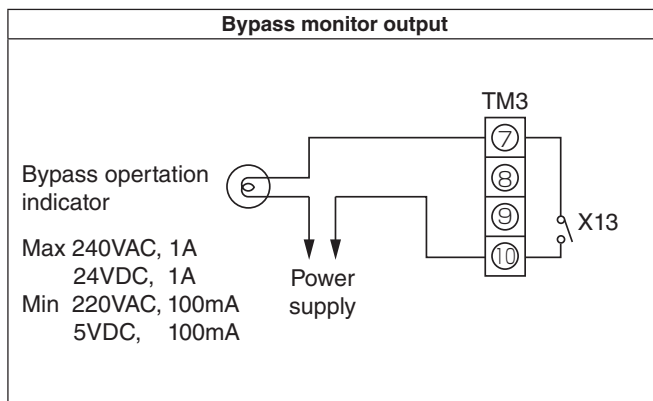

#### 8.1.2 Malfunction monitor output

This function is to enable Lossnay error display when there is no remote controller which can display error.

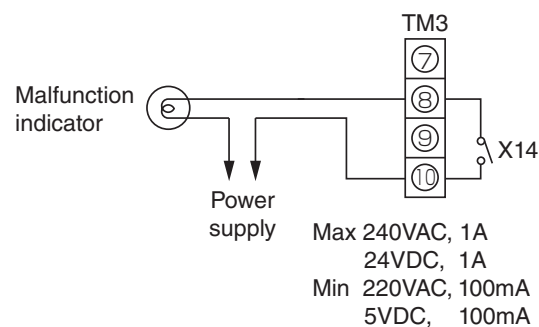

**8.1.3 Operation monitor output**

Operation monitor output can be selected for exhaust fan or supply fan.  
 Also supply fan delay operation, ex. for after-heater, can be set.  
 Always check that it is the intended setting.

DIP-SW		Setting check	PZ-61DR-E		Setting check	Operation monitor output from TM3 <sup>⑨⑩</sup>
SW No.	Setting		Function No.	Setting Data		
SW2-8 SW5-2	-	-	57	0 (Factory setting)		DIP-SW priority
	2-8 OFF 5-2 OFF (Factory setting)			1		Operation monitor output
	2-8 OFF 5-2 ON			2		SA fan monitor output * When supply fan stops during cold outdoor temp. or defrosting, output stops.
	2-8 ON (Either 5-2 ON or OFF)			3		SA fan operation monitor output with delayed operation.

**<Operation monitor output>**

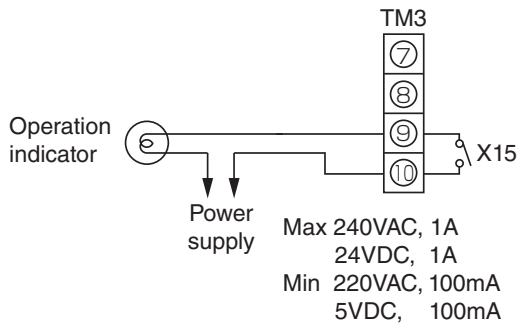

**<Supply fan operation monitor output with delayed operation>**

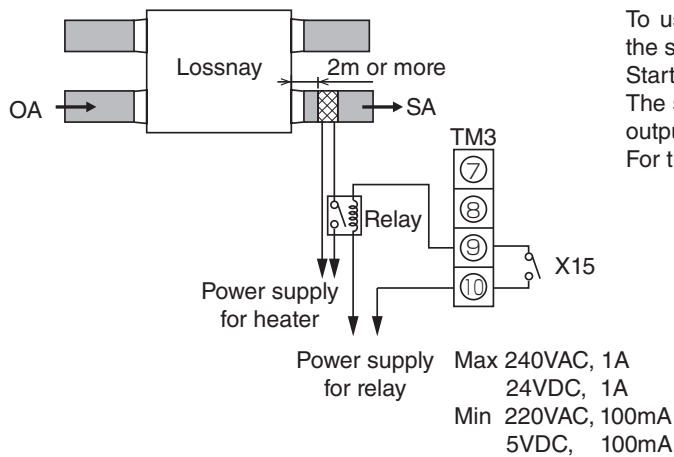

To use operation monitor output for a supply after-heater, use the supply fan operation monitor output with delayed operation. Starts the output 10 seconds after supply fan operates. The supply fan continues to operate for 3 min after stopping the output. For the heater, observe the cautions listed in C-49.

## 8.2 Input terminal

### 8.2.1 ON/OFF switching by using CN32 (When using the remote/local switching and the ON/OFF input)

Use when intending to prohibit switching ON/OFF from remote controller or centralized controller.

■ In the case of using 2 switches (field supply) for ON/OFF

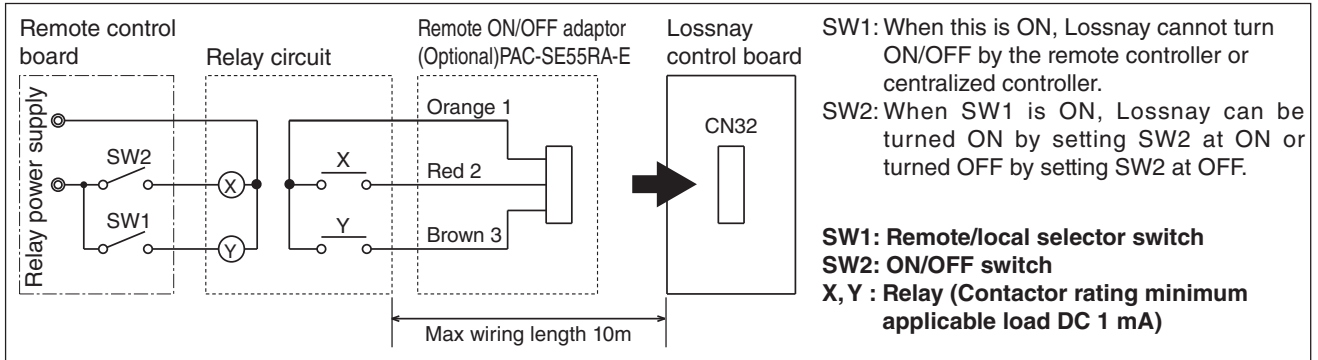

**Note;**

Cannot use together with external input signal by TM2.

When using in a group of multiple Lossnay units, be sure to connect to main unit. Refer to page C-9.

Connect the TM4①② of each Lossnay unit.

In the case that Lossnay is connected to MELANS, operation lock from system controller has a priority.

■ In the case of forcing stop

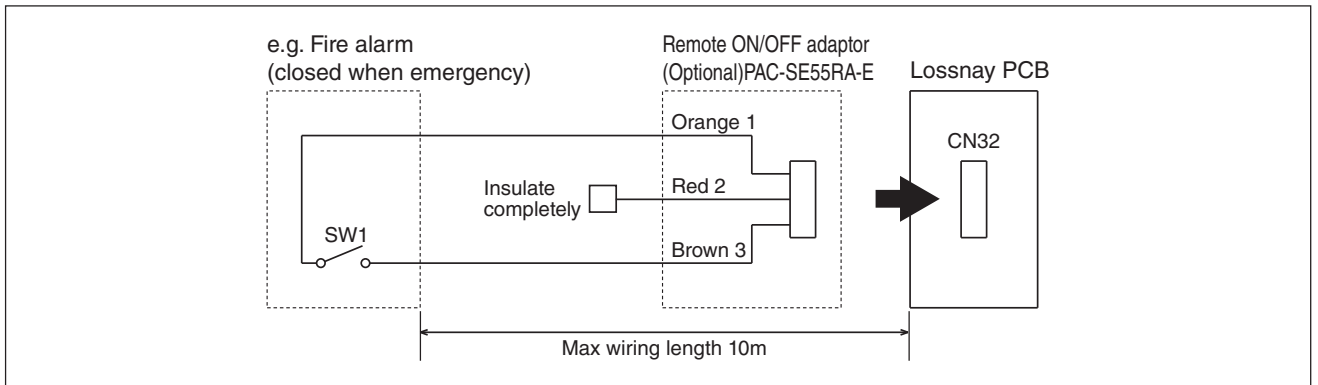

**8.2.2 External fan speed control (Volt-free contact, CN17)**

Lossnay changes fan speed by external input from field supply CO<sub>2</sub> sensor, etc.

Using a field supply sensor, etc., make connection by inserting the optional remote display adaptor (PAC-SA88HA-E) in the connector CN17 (Red) as shown by the figure.

**<Operation>**

When external fan speed control is activated, the icon  will be displayed on PZ-61DR-E and it is not possible to change fan speed from PZ-61DR-E. In the case of using the other remote controller, it is possible to change the display of fan speed, however the actual fan speed is the fan speed that is set by the external control, i.e. the external fan speed control has higher priority.

**<How to set>**

Lossnay will operate the fan speed as shown in the table below, regardless of the remote controller setting.

CN17(Red)	Fan speed
1-2 (Brown-Red)	4
1-3 (Brown-Orange)	3
1-4 (Brown-Yellow)	2
1-5 (Brown-Green)	1

**<Wiring example of “Fan speed 4”>**

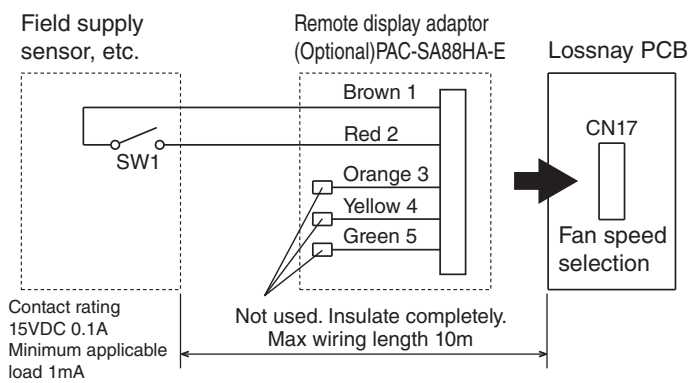

Use this in such a way that it ventilates at fan speed 1, 2 or 3 normally, and when the external sensor detects contamination of indoor air, it changes to fan speed 4 operation.

**<Multiple Lossnay units control>**

Refer to 8.2.5 (page C-57)

**8.2.3 External fan speed control (Analogue input 0 - 10 VDC, CN26)**

Lossnay changes fan speed according to input voltage to CN26 from a field supply CO<sub>2</sub> sensor or a BMS (Building Management System) etc. When using this function, the external fan speed control by volt-free contact (CN17) is not available.

**<Operation>**

When external fan speed control is activated, the icon  will be displayed on PZ-61DR-E and it is not possible to change fan speed from PZ-61DR-E. In the case of using the other remote controller, it is possible to change the display of fan speed, however the actual fan speed is the fan speed that is set by the external control, i.e. the external fan speed control has higher priority.

When pattern X or Y is selected, it is not possible to change fan speed from remote controllers. (External input has higher priority)

**<How to select pattern>**

Set external fan speed input setting by DIP-SW or function **No.63** from PZ-61DR as following table.

DIP-SW		Setting check	PZ-61DR-E		Setting check	External fan speed control using CN26
SW No.	Setting		Function No.	Setting Data		
SW2-3 SW2-6	-	-	63	0 (Factory setting)		DIP-SW priority
	2-3 OFF 2-6 OFF (Factory setting)			1		External fan speed control is N/A.
	2-3 ON 2-6 OFF			2		Refer to Pattern X
	2-3 OFF 2-6 ON			3		Refer to Pattern Y
	2-3 ON 2-6 ON			4		Refer to Pattern Z

<Differentiation of each pattern>

[Pattern X]

When the input voltage is more than 6.0 VDC, Lossnay operates at fan speed 4 (maximum air volume). Lower voltage than 6.0 VDC, Lossnay operate at lower fan speed. (Connection example: if you use a CO<sub>2</sub> sensor which 0 - 10 VDC equals to 0 - 2000 ppm, 6.0 VDC equals to 1200 ppm)

Input voltage [VDC]	CO <sub>2</sub> concentration [ppm]	Fan speed
0 - 2.6	0 - 520	1
3.0 - 4.1	600 - 820	2
4.5 - 5.6	900 - 1120	3
6.0 or mote	1200 or mote	4

**Note;**

- Input voltage and CO<sub>2</sub> concentration are guidelines, not guaranteed values.  
When the input voltage is in-between, operating fan speed depends on the situations.
- Please select a CO<sub>2</sub> sensor which the relationship formula between CO<sub>2</sub> concentration and output voltage is "2000ppm=10VDC."

[Pattern Y]

When the input voltage is more than 5.0 VDC, Lossnay operates at fan speed 4 (maximum air volume). Lower voltage than 5.0 VDC, Lossnay operate at lower fan speed. (Connection example: if you use a CO<sub>2</sub> sensor which 0 - 10 VDC equals to 0 - 2000 ppm, 5.0 VDC equals to 1000 ppm)

Input voltage [VDC]	CO <sub>2</sub> concentration [ppm]	Fan speed
0 - 2.1	0 - 420	1
2.5 - 3.4	500 - 680	2
3.8 - 4.6	760 - 920	3
5.0 or mote	1000 or mote	4

**Note;**

- Input voltage and CO<sub>2</sub> concentration are guidelines, not guaranteed values.  
When the input voltage is in-between, operating fan speed depends on the situations.
- Please select a CO<sub>2</sub> sensor which the relationship formula between CO<sub>2</sub> concentration and output voltage is "2000ppm=10VDC."

[Pattern Z]

Lossnay changes fan speed as the table below.

Input voltage [VDC]	Fan speed	Fan speed changing from Remote controller
0 - 1.0	-	Available
1.5 - 2.5	1	Not available
3.5 - 4.5	2	Not available
5.5 - 7	3	Not available
8.5 - 10	4	Not available

When the input voltage is in-between, it will cause unstable operation.

When the input voltage is 0 - 1.0 VDC, control from the remote controller is available.

<Wiring>

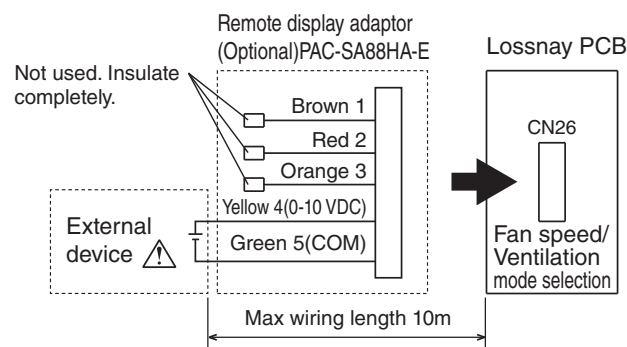

**CAUTION**

- Make sure of correct polarity.

<Multiple Lossnay units control>

Refer to 8.2.5 (page C-57)

**8.2.4 External Bypass control (CN26)**

The ventilation mode of Lossnay is changed to Bypass mode by input from external switch, etc. When SW1 is “ON”, the ventilation mode of Lossnay is changed to the Bypass mode regardless of the setting on the remote controller.

**<Operation>**

When external ventilation mode control is activated, the icon  will be displayed on PZ-61DR-E and it is not possible to change ventilation mode from PZ-61DR-E. When using other remote controllers it is also not possible to change ventilation mode (Once changed, but return automatically). In other word, the external ventilation mode control has higher priority.

**Note;**

- When the outdoor air temperature drops lower than 8°C, it changes to the energy recovery mode in spite of the input. (Display of the remote controller does not change.)

**<Wiring>**

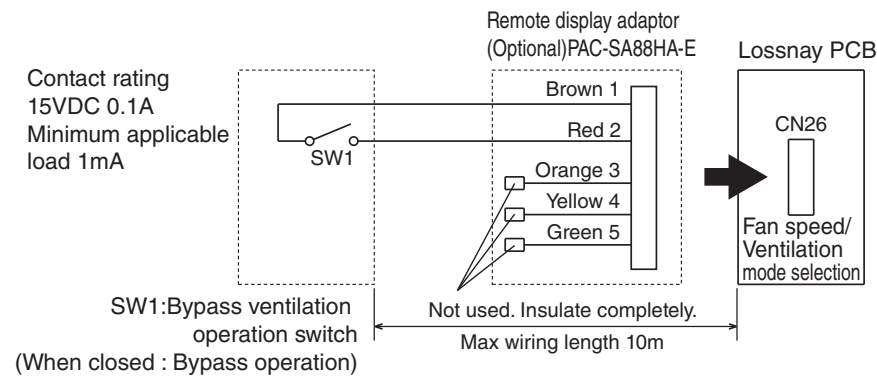

**<Multiple Lossnay units control>**

Refer to 8.2.5 (page C-57)



### 8.2.5 Sub unit setting (Multiple Lossnay units control by external input)

When using PZ-61DR-E, it is necessary for sub unit to select 'Main unit input priority' or 'Individual input priority'. This function is available to the following external input;

- External fan speed control (CN17 and CN26)
- External Bypass control (CN26)

When not using PZ-61DR-E, sub unit does not follow the main unit. See the case 3 below.

<How to set>

DIP-SW		Setting check	PZ-61DR-E		Setting check	Input priority setting
SW No.	Setting		Function No.	Setting Data		
N/A	-	-	34	0 (Factory setting)		Main unit input priority
	-	-		1		Individual input priority

<Usage examples>

**Case 1** Sub units follow the main unit

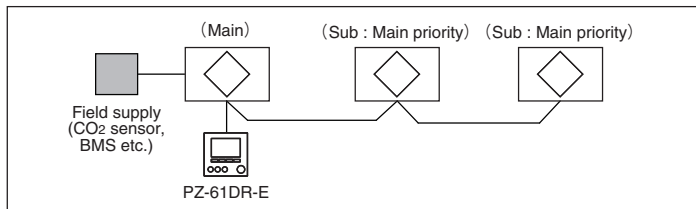

**Note;** To control sub units by one CO<sub>2</sub> sensor, PZ-61DR-E is necessary.

**Case 2** Sub 1 unit follows the individual input from CO<sub>2</sub> sensor, sub 2 unit follows the main unit

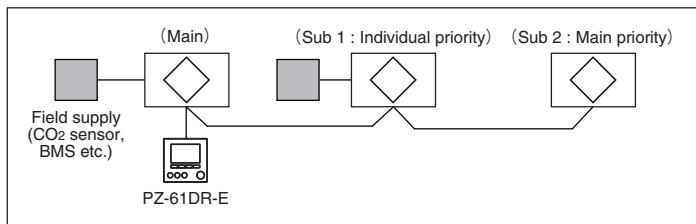

**Case 3** Sub units do not follow the main unit

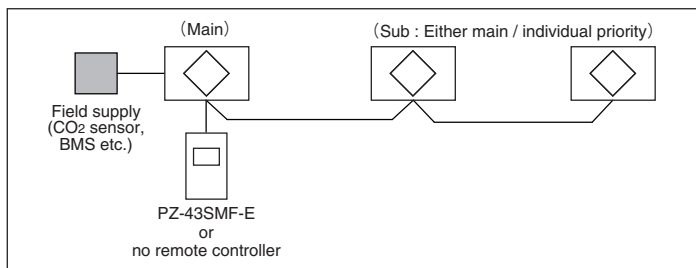

**DO NOT** make a system like below.

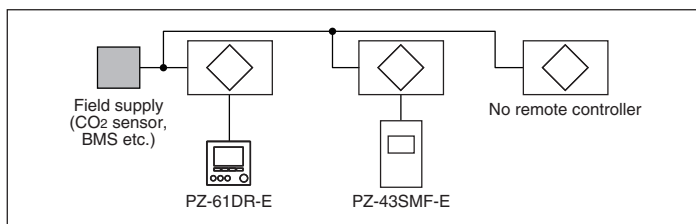

<Caution>

- To input volt-free contact and analogue voltage from one contact or voltage supply into multiple Lossnay PCB is prohibited. Some malfunction will occur.

## 1. Lossnay Remote Controller (PZ-61DR-E)

### 1.1 Controller interface

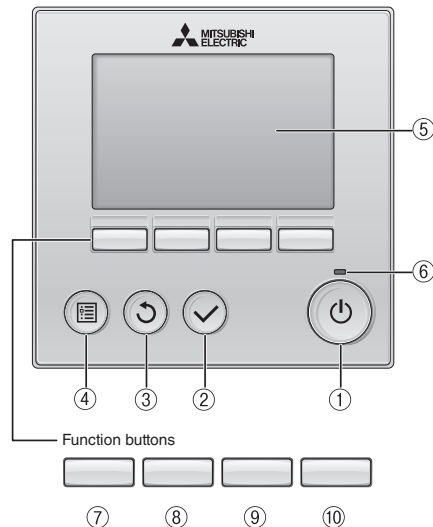

#### ① ON/OFF button

Press to turn ON/OFF the Lossnay unit.

#### ② SELECT button

Press to save the setting.

#### ③ RETURN button

Press to return to the previous screen.

#### ④ MENU button

Press to bring up the Main menu.

#### ⑤ Backlit LCD

Operation settings will appear.

When the backlight is off, pressing any button turns the backlight on and it will stay lit for a certain period of time depending on the screen.

When the backlight is off, pressing any button turns the backlight on and does not perform its function. (except for the ON/OFF button)

#### ⑥ ON/OFF lamp

This lamp lights up in green while the unit is in operation. It blinks while the remote controller is starting up or when there is an error.

The functions of the function buttons change depending on the screen. Refer to the button function guide that appears at the bottom of the LCD for the functions they serve on a given screen.

When the system is centrally controlled, the button function guide that corresponds to the locked button will not appear.

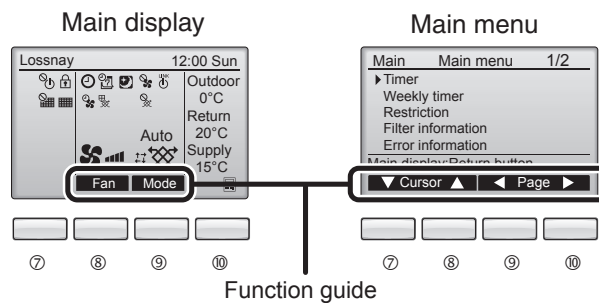

#### ⑦ Function button F1

Main menu: Press to move the cursor down.

#### ⑧ Function button F2

Main display: Press to change the fan speed.  
Main menu: Press to move the cursor up.

#### ⑨ Function button F3

Main display: Press to change the ventilation mode  
Main menu: Press to go to the previous page.

#### ⑩ Function button F4

Main menu: Press to go to the next page.

\* If LOSSNAY does not have the function or operation is not possible, the operation guide is not displayed.

## 1.2 Display

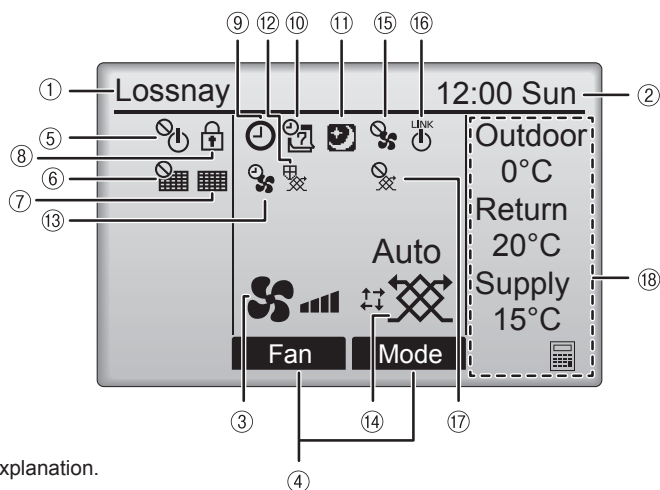

\* All icons are displayed for explanation.

### ① Remote controller name

Lossnay is always displayed.

### ② Clock (See the Installation Manual.)

Current time appears here.

### ③ Fan speed

Fan speed setting appears here.

### ④ Button function guide

Functions of the corresponding buttons appear here.



Appears when the ON/OFF operation is centrally controlled.



Appears when the filter reset function is centrally controlled.



Indicates when filter and/or Lossnay core needs maintenance.



Appears when the buttons are locked and/or a fan speed is skipped.



Appears when the On/Off timer, or Auto-off timer function is enabled.



Appears when the Weekly timer is enabled.



Appears when the night-purge function is available.



Appears when performing operation to protect the equipment.



Appears when performing the power supply/exhaust function or the delay operation at the start of operation.

### ⑭ Ventilation mode

Indicates the ventilation mode setting.



Appears when external fan speed operation.



Appears when operation interlocked with external unit.



Appears when external ventilation mode operation.

### ⑱ Temperature

Displays the outdoor temperature, return temperature, and supply temperature (calculated value).

The outdoor temperature indication flashes when 0°C or lower or 38°C or higher.  
The return temperature and supply temperature (calculated value) indications flash when 8°C or lower or 38°C or higher.

Most settings (except ON/OFF, fan speed, ventilation mode) can be made from the Menu screen.

## 2. Lossnay Remote Controller (PZ-43SMF-E)

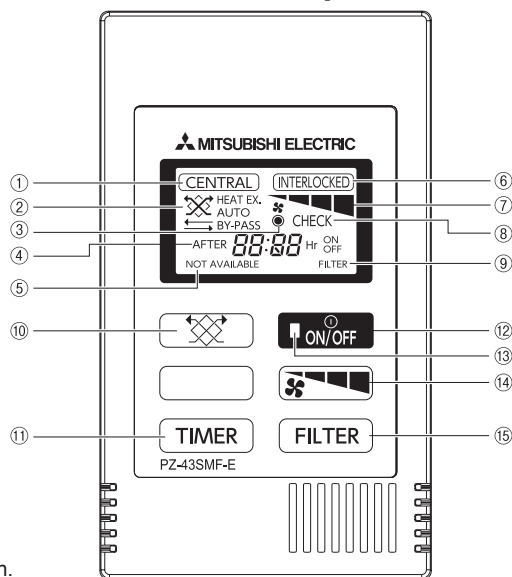





\* All icons are displayed for explanation.

### 1 [CENTRAL] Display

Displayed during remote operation prohibited by centralized control unit, etc.

### 2 Ventilation mode

Displayed the ventilation mode status.

- Heat exchange  HEAT EX.
- Bypass  BY-PASS
- Automatic (HEAT EX./Bypass)  HEAT EX. AUTO  
or  
AUTO  
 BY-PASS

### 3 Power Display

Displayed while the Lossnay remote controller is powered on.

### 4 [TIMER] Display

Displayed on-timer or off-timer duration.

### 5 [NOT AVAILABLE] Display

When a button is pressed for a function which the Lossnay unit cannot perform, this display flashes concurrently with the display of the function.

### 6 [INTERLOCKED] Display

Displayed when the Lossnay starts off by interlocked indoor unit or external signal.

### 7 Fan speed Display

Displayed the selected fan speed.

### 8 [CHECK] Display

Displayed together with the malfunctioning unit (3 digits) and an error code (4 digits).

#### Note:

-When power is restored after an outage or when the corresponding breaker for the distribution box is reset, all models will return to the condition before the supply of power was interrupted.

-When the back light is off, the first pressing any button (except "ON/OFF" button) will not activate but make the back light on.

### 9 [FILTER] Display

Displayed when the accumulated operating time reaches at the time set for filter maintenance.

### 10 [Ventilation mode] Button

Used to select the ventilation mode among heat exchange, Bypass or automatic.

### 11 [TIMER] Button

Increasing 0:30 by pressing it once.  
Keep pressing the button for fast-forwarding.

### 12 [ON/OFF] Button

Switch for start and stop.

### 13 Operation lamp

On during operation. Flashes when a malfunction occurs.

### 14 [Fan Speed] Button

Used to select the fan speed either "Low" or "High"

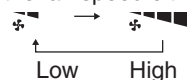

Note: If this button is pressed when trying to switch the fan speed of a Lossnay unit which is not equipped with the fan speed adjustment, the fan speed display and NOT AVAILABLE display flash and the unit's fan speed does not change.

### 15 [FILTER] Button

Press twice to reset the filter sign display.

## 1. Name of components in control box

With this product, the wiring installation method will vary according to the design of the system. Perform electrical installation to meet local electrical regulations.

\* Always use double insulated PVC cable for the transmission cables.

\* Wiring work must be performed by qualified professionals.

\* All supply circuits must be disconnected before obtaining access to the terminal devices.

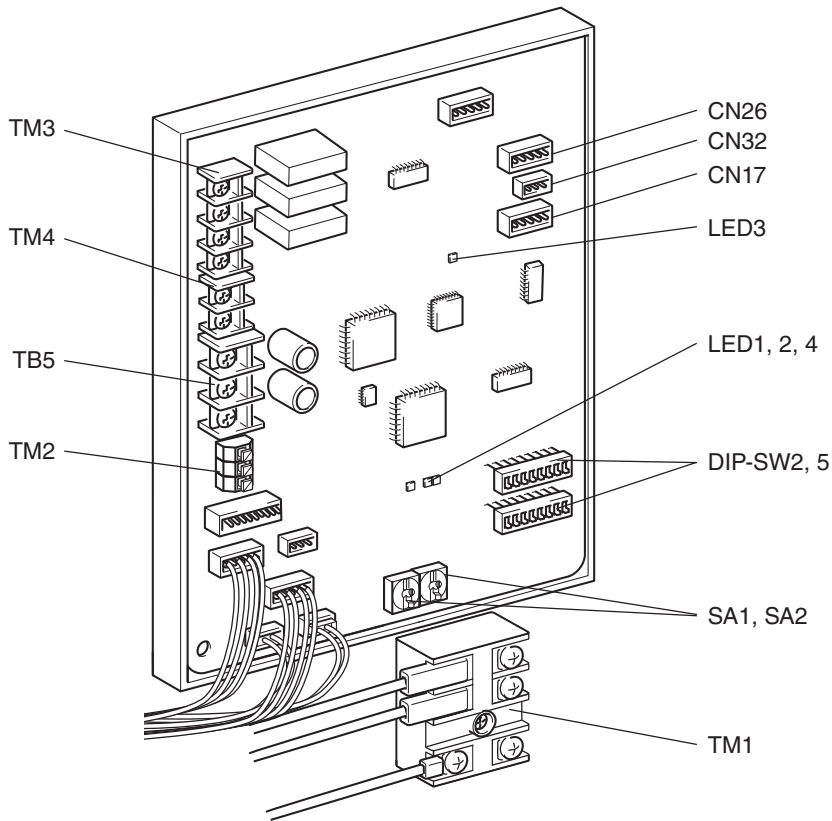

## 2. Wiring diagram --- Models LGH-15 to 100 RVX-E

- \* TM1, TM2, TM3, TM4, TB5 shown in dotted lines are field work.
- \* Be sure to connect the ground wire.
- \* A power supply isolator must be installed.
- \* Always use an isolator for the main switch power connection.

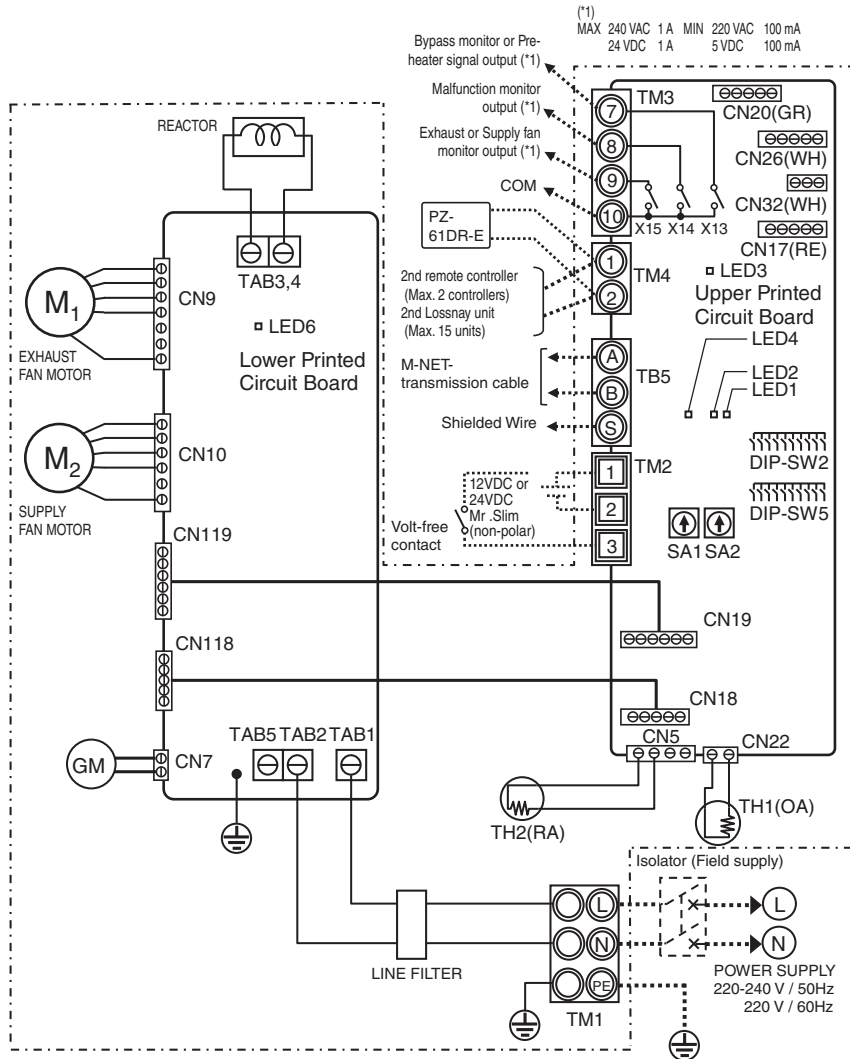

Definition of symbols		
M1: Motor for exhaust fan	X13: Relay contact	CN26: Connector (Bypass, 0 - 10 VDC Fan speed control)
M2: Motor for supply fan	X14: Relay contact	CN32: Connector (Remote control selection)
GM: Motor for Bypass damper	X15: Relay contact	SA1: Address setting rotary switch (10 digit)
TH1: Thermistor for outside air	CN5: Connector (Thermistor RA)	SA2: Address setting rotary switch (1 digit)
TH2: Thermistor for return air	CN7: Connector (Motor for Bypass damper)	LED1 to LED3: Inspection indicator lamp
SW2,5: Switch (Function selection)	CN9: Connector (Fan motor)	LED4, LED6: Power supply indicator lamp
TM1: Terminal block (Power supply)	CN10: Connector (Fan motor)	SYMBOL ○ □: Terminal block
TM2: Terminal block (External control input)	CN17: Connector (Fan speed 1/2/3/4)	⊗ : Connector on PCB
TM3: Terminal block (Monitor output)	CN18: Connector	
TM4: Terminal block (Transmission cable)	CN118: Connector	
TB5: Terminal block (M-NET Transmission cable)	CN19: Connector	
TAB1, TAB2, (TAB5): Connector (Power supply)	CN119: Connector	
TAB3, TAB4: Connector (Reactor)	CN22: Connector (Thermistor OA)	

### 3. Wiring diagram --- Models LGH-150 and 200 RVX-E

- \* TM1, TM2, TM3, TM4, TB5 shown in dotted lines are field work.
- \* Be sure to connect the ground wire.
- \* A power supply isolator must be installed.
- \* Always use an isolator for the main switch power connection.

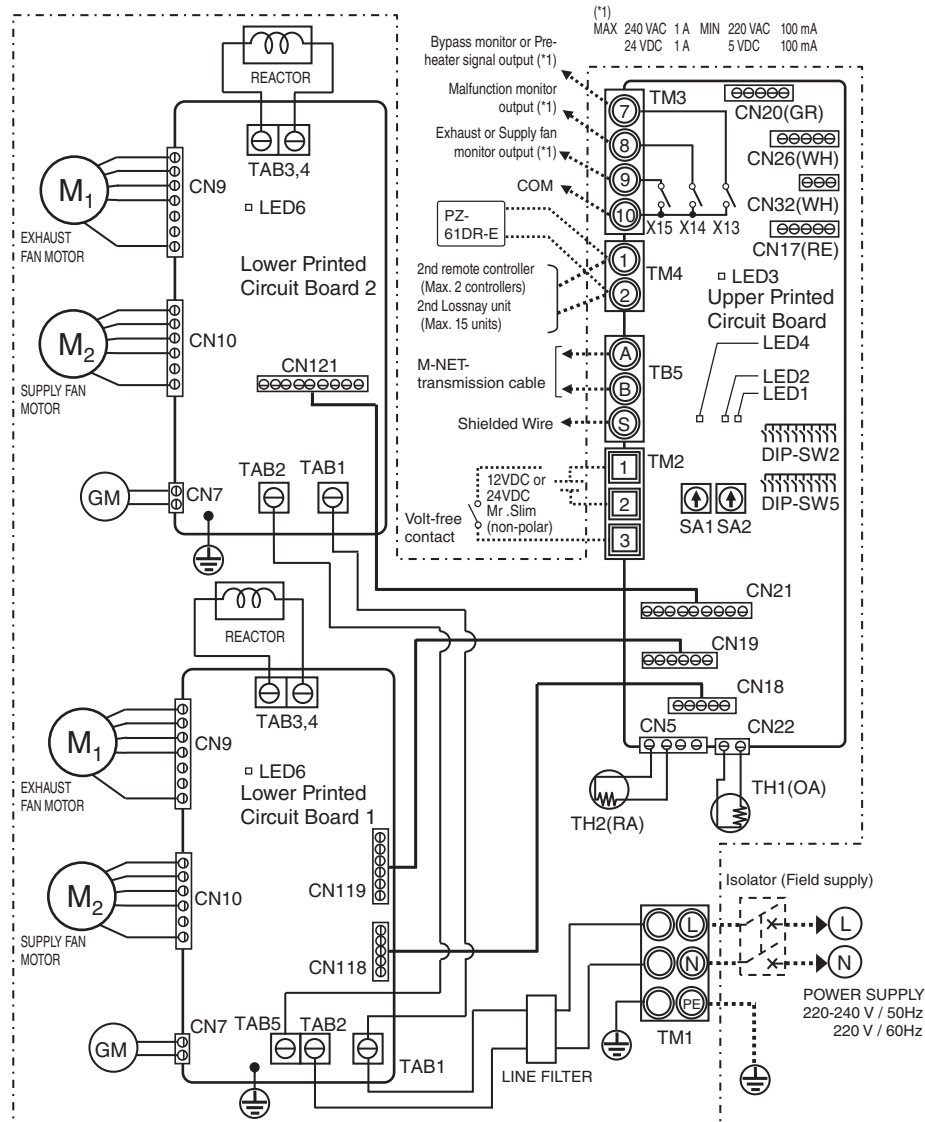

Definition of symbols		
M1: Motor for exhaust fan	X13: Relay contact	CN21: Connector
M2: Motor for supply fan	X14: Relay contact	CN121: Connector
GM: Motor for Bypass damper	X15: Relay contact	CN22: Connector (Thermistor OA)
TH1: Thermistor for outside air	CN5: Connector (Thermistor RA)	CN26: Connector (Bypass, 0 - 10 VDC Fan speed control)
TH2: Thermistor for return air	CN7: Connector (Motor for Bypass damper)	CN32: Connector (Remote control selection)
SW2, 5: Switch (Function selection)	CN9: Connector (Fan motor)	SA1: Address setting rotary switch (10 digit)
TM1: Terminal block (Power supply)	CN10: Connector (Fan motor)	SA2: Address setting rotary switch (1 digit)
TM2: Terminal block (External control input)	CN17: Connector (Fan speed 1/2/3/4)	LED1 to LED3: Inspection indicator lamp
TM3: Terminal block (Monitor output)	CN18: Connector	LED4, LED6: Power supply indicator lamp
TM4: Terminal block (Transmission cable)	CN118: Connector	SYMBOL : Terminal block
TB5: Terminal block (M-NET Transmission cable)	CN19: Connector	: Connector on PCB
TAB1, TAB2, TAB5: Connector (Power supply)	CN119: Connector	
TAB3, TAB4: Connector (Reactor)		

**MITSUBISHI ELECTRIC CORPORATION**