

SERVICE PARTS LIST FOR MITSUBISHI ELECTRIC PACKAGED AIR-CONDITIONERS

Series : PWFY-P•VM-E

REVISED

Jan. 2009

BWE0810A

INDEX
<p>PWFY-P100VM-E-BU PWFY-P100VM-E-AU PWFY-P200VM-E-AU</p>



PWFY-P100VM-E-BU
PWFY-P100VM-E-AU
PWFY-P200VM-E-AU

EXTERNAL PARTS

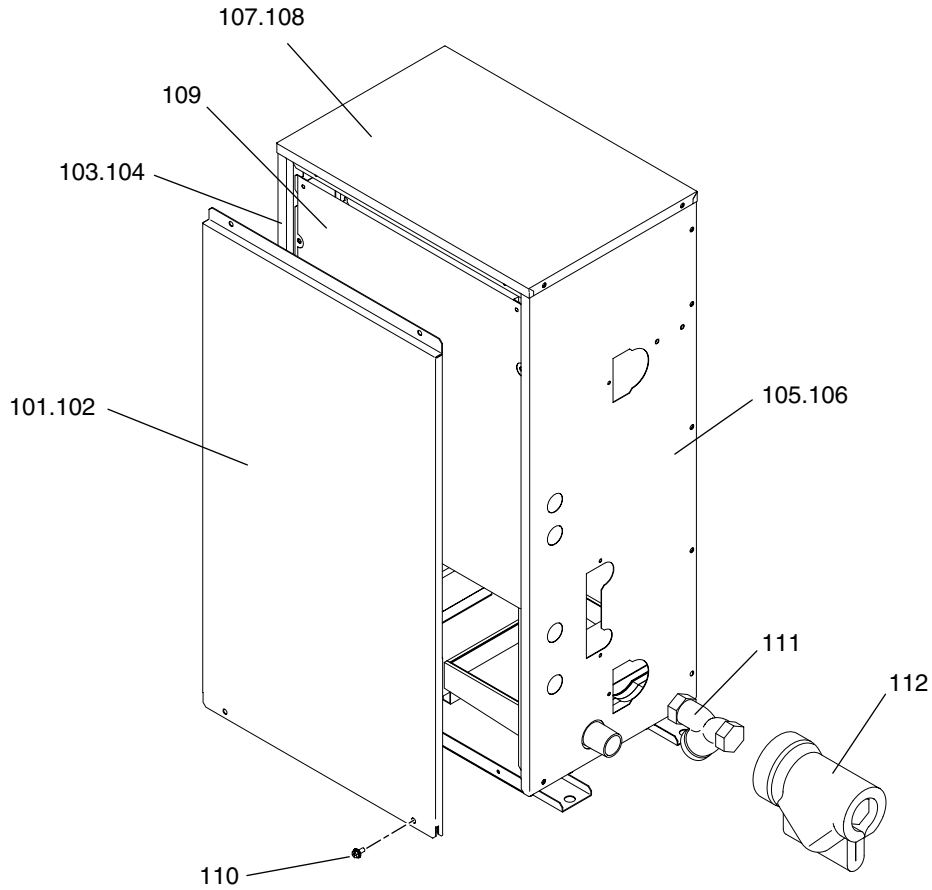

No.	Part No.	G : RoHS Apply Only W : RoHS Apply by Running Change		Spec.	PWFY-P100VM-E-BU	PWFY-P100VM-E-AU	PWFY-P200VM-E-AU			Dwg. No.	Price	Revision History
			Part Name									
101	R61 084 651	G	Panel F assy		1					KB00K970G01		
102	R61 085 651	G	Panel F		1	1				KB02L998H01		
103	R61 086 651	G	Panel R assy		1					KB00R058G02		
104	R61 087 651	G	Panel R		1	1				KB02B899H01		
105	R61 088 651	G	Panel SR assy		1					KB00K972G02		
106	R61 089 651	G	Panel SR		1	1				KB02B900H01		
107	R61 090 651	G	Panel T assy		1					KB00R053G01		
108	R61 091 651	G	Panel T		1	1				KB02L999H02		
109	R61 036 232	G	Sheet FR60		1	1	1			KE73D404H01		
110	R63 007 087	G	H Screw	5x14 KNURLED (30Pcs)	1	1	1			KB00H418G02		
111	R61 006 454	G	Strainer 3/4B		1	1	1			P641135X01		
112	R61 006 600	G	Insulator		1	1	1			KB33L902G01		

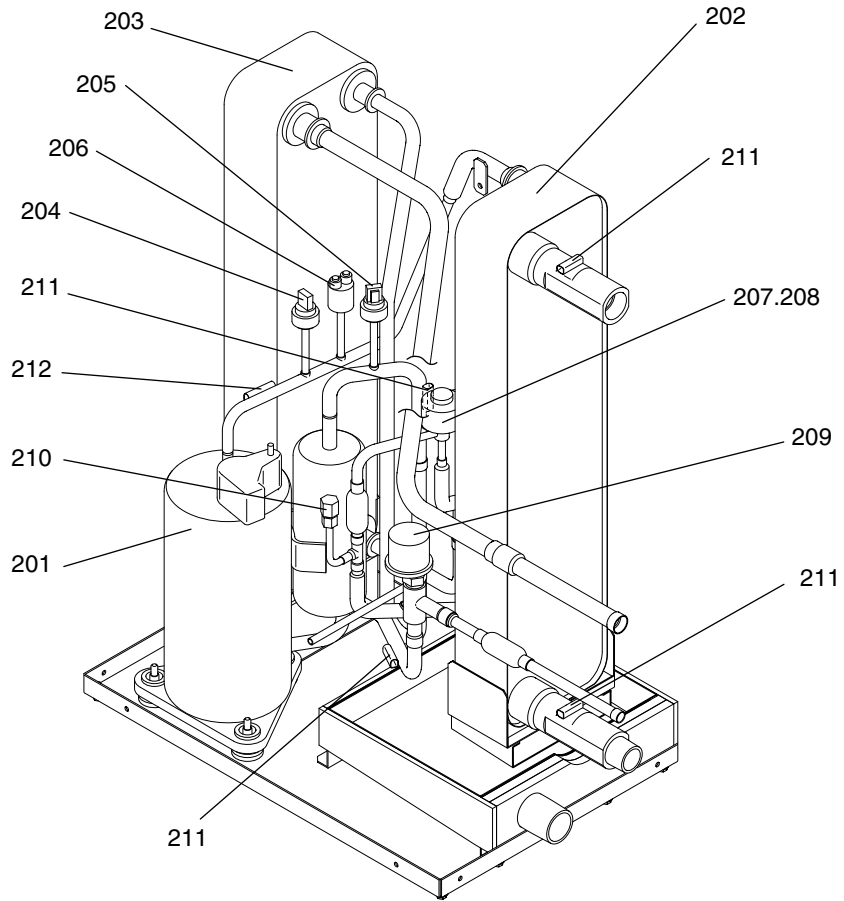

No.	Part No.	G : RoHS Apply Only W : RoHS Apply by Running Change		Spec.	PWFY-P100VM-E-BU					Dwg. No.	Price	Revision History
			Part Name									
201	R69 051 478	G	Compressor	SBB172FDG	1					P720046X01		A
202	R61 225 480	G	Heat exchanger assy		1					KB00R120G01		
203	R61 239 480	G	Heat exchanger assy		1					KB00R121G02		
204	R61 010 288	G	Pressure sensor	HP <63HS>	1					P418048X01		
205	R61 011 288	G	Pressure sensor	LP <63LS>	1					P418052X01		
206	R61 003 208	G	Pressure switch	ACB-1UB57W <63H1>	1					P426330X01		
207	R63 4H6 401	G	Linear expansion valve	CAM35-S	1					P632444X01		
208	R61 018 401	G	Linear expansion valve coil	CAM <LEV2W>	1					P472053X01		
209	R63 004 401	G	Linear expansion valve	EFM-80YGMD-4 <LEV1W>	1					P632453X01		
210	R63 F14 413	G	Check joint		1					P639131X01		
211	R61 060 200	G	Thermistor	<TH6,TH8,TH13,TH22>	4					P418065X01		
212	R63 911 202	G	Thermistor	<TH11>	1					P425416X02		

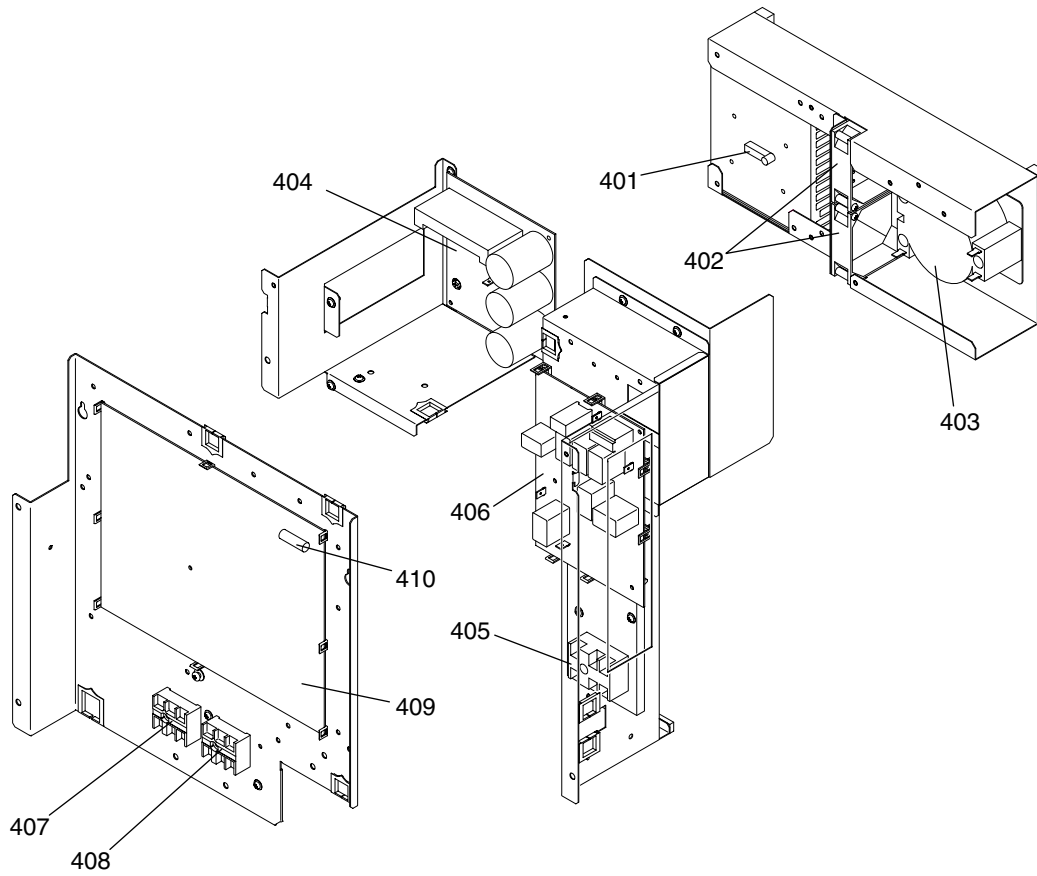

No.	Part No.	G : RoHS Apply Only W : RoHS Apply by Running Change		Spec.	PWFY-P100VM-E-BU						Dwg. No.	Price	Revision History
			Part Name										
401	R63 P89 200	G	Thermistor	<THHS>	1						P418011X01		
402	R61 001 198	G	Fan		2						P712410X01		
403	R61 015 259	G	Reactor	<ACL>	1						P715451X01		
404	R61 075 280	G	INV board		1						W647875G12		
405	R61 002 246	G	Terminal block	<TB2>	1						BG00R200G26		
406	R61 006 293	G	Noise filter		1						KE80C276G01		
407	R61 003 246	G	Terminal block	<TB5>	1						BG00R200G45		
408	R61 016 246	G	Terminal block	<TB15>	1						KE00D459G01		
409	R61 024 281	G	Control board		1						KE80C274G01		
410	R63 993 964	G	Fuse	6.3A AC250V T <F01>	1						S423001H30		

