

FRESH MASTER

HAND BOOK

FOR DEALERS

Model: GUF-50RD3
GUF-100RD3

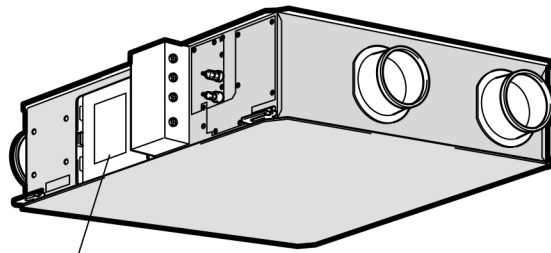

Model name

The picture is shown GUF-50RD3.
Humidifier function not available.

Notice:

The term of validity is for a year from the issued date.

5. Parts list

Please note the following when using the parts list.

1. When ordering parts, always indicate the part number, part name, and number of parts required.
2. Parts are not always available, and it may take time for you to receive them.
3. There may be specification improvements or prices changes.
4. Specifications and prices are as of July 2004.
5. Parts marked \triangle are critical for safety. To maintain safety and performance, always replace these parts with the parts prescribed.
6. The numbers that are circled in the exploded view are the same as the reference number for the part being indicated.

Description of screw abbreviations

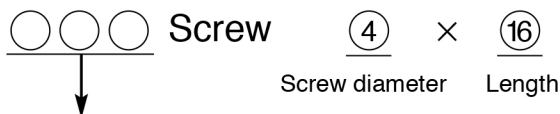

Abbreviation	Description
PC screw	Cross recess flat head machine screw
PRC screw	Cross recess oval head machine screw
PP screw	Cross recess pan head machine screw
SW · PP screw	Cross recess pan head screw with spring washer
PPT screw	Cross recess tapping screw
PCT screw	Cross recess flat head tapping screw
PTT screw	Cross recess truss head tapping screw
PT screw	Cross recess truss head machine screw
SET screw	Slotted head stop screw
SQ · SET screw	Square head stop screw
P · SET screw	Pan head stop screw
PMT screw	Primer truss head screw
HS · SET screw	Hexagon head stop screw
P · R · W screw	Cross recess round wood screw
P · C · W screw	Cross recess flat head wood screw
P · R · C · W screw	Cross recess round and flat wood screw
R · W screw	Slotted round wood screw
PW · PP screw	Cross recess pan head screw with small washer
SW-PW · PP screw	Cross recess pan head machine screw with spring washer and flat washer

Model GUF-50RD3

No.	Parts No.	Name of part	Q'ty pcs/unit	Critical for safety	Remarks	Price
1.	Y50 062 718	Filter	2	▲		
2.	H00 000 488	PTT screw 4×12	2			
3.	R50 216 381	Core guide	1			
4.	R50 216 710	Lossnay core	2	▲		
5.	R50 263 381	Core guide	1			
6.	R50 474 737	Linear expansion valve	1	▲		
7.	H00 000 487	PTT screw 4×8	38			
8.	R50 028 610	Flange	4			
9.	R50 351 708	Cover	2			
10.	R50 466 344	Hinge	1			
11.	Y50 029 712	Fix plate	1			
12.	R50 095 380	Hanger	4			
13.	H00 000 244	PT screw 6×12	8			
14.	M34 074 017	Special screw 4×11	1			
15.	R50 429 691	Cover(L)	1			
16.	Y55 009 366	Model name	1			
17.	X50 002 707	Meintenanace cover	1			
18.	H00 189 007	PTT screw 5×10	13			
19.	R50 429 697	Cover(S)	1			
20.	R50 429 698	Humidifier cover	1			
21.	R50 429 700	Fix plate	1			
22.	R50 429 699	Fix plate	1			
23.	R40 647 340	Thermistor	1	▲	Liquid pipe	
23.	R40 632 936	Thermistor	1	▲	Gas pipe	
24.	R50 429 486	Humidifier cover(IN)	1			
25.	R50 117 708	Water sensor	2	▲		
26.	M35 282 045	Special screw 4×12	1			
27.	H00 260 045	PPT screw 4×8	5			
28.	Y55 007 692	Water sensor plate	1			
29.	R50 472 699	Heat exchanger	1	▲	Refrigerant	

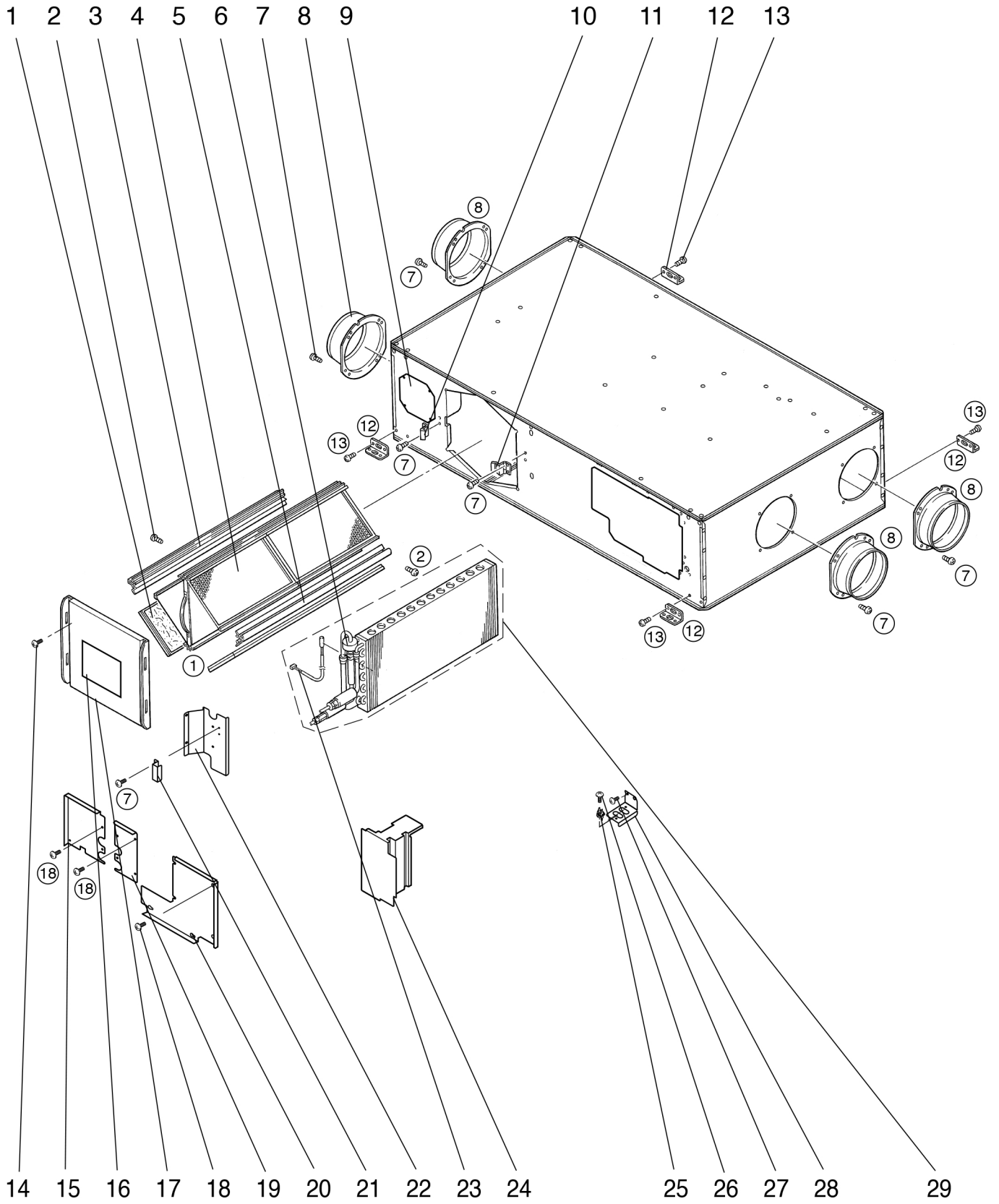

Model GUF-50RD3

No.	Parts No.	Name of part	Q' ty pcs/unit	Critical for safety	Remarks	Price
51.	R50 331 067	Special nut	2			
52.	M34 398 077	Tab washer	2			
53.	R50 351 480	Centrifugal fan	2	▲	φ 220	
54.	R50 478 707	Motor base	2			
55.	M34 706 465	Special washer	2			
56.	Y50 062 452	Motor	1	▲		
57.	R50 351 713	Motor fix plate	2			
58.	H00 189 007	PTT screw 5x10	16			
59.	Y55 003 451	Motor	1	▲		

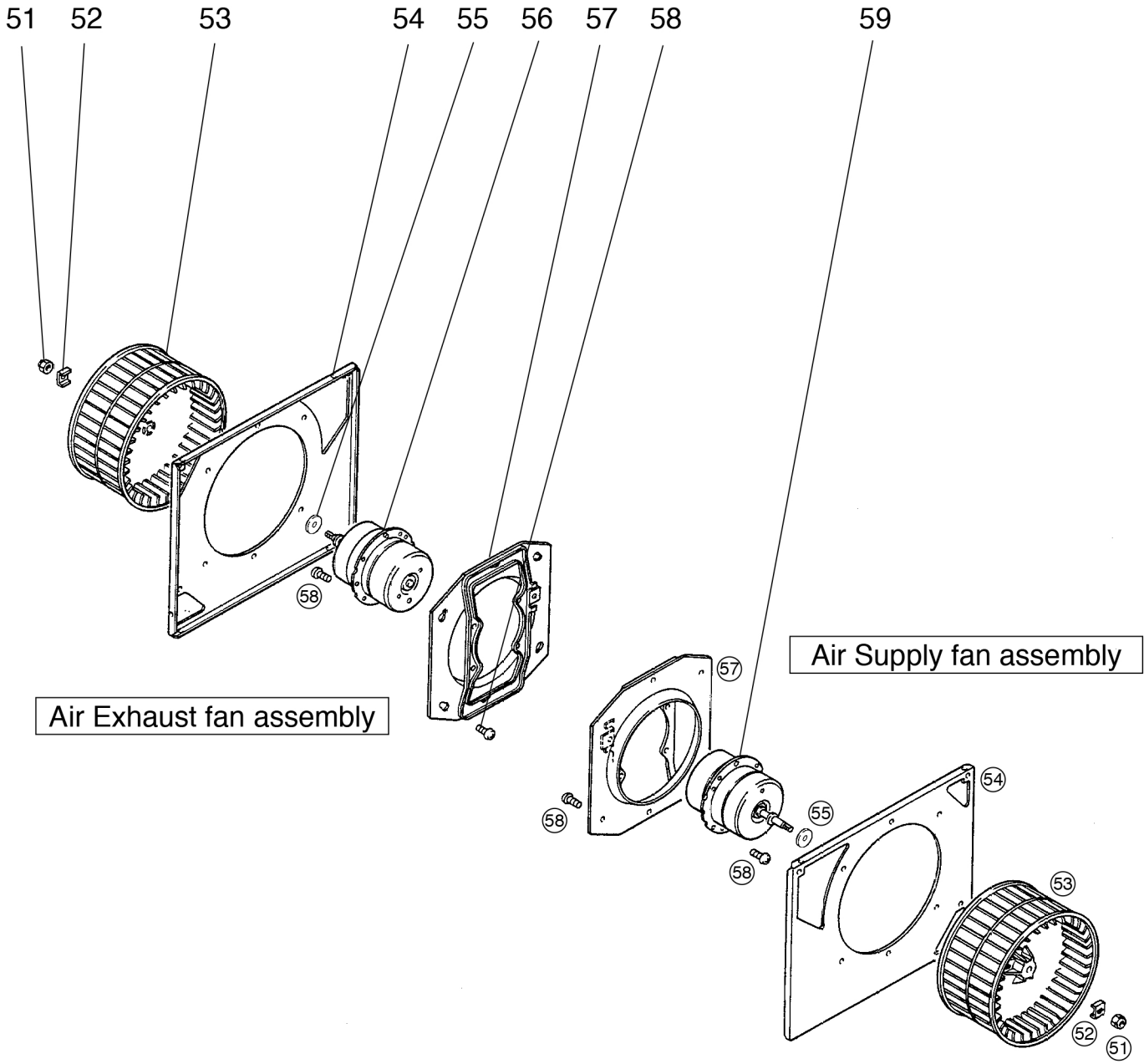

Model GUF-50RD3

No.	Parts No.	Name of part	Q'ty pcs/unit	Critical for safety	Remarks	Price
71.	R50 472 716	Damper support	1			
72.	R50 069 156	Pull spring	1			
73.	R50 054 225	Bush	2			
74.	R50 232 150	Rod	1			
75.	Y50 061 693	Damper motor cover	1			
76.	Y50 061 260	Damper motor	1	▲	220×240V	
77.	H00 312 007	PTT screw 4×6	2			
78.	Y55 003 216	Thermistor	1	▲		
79.	D41 093 224	Cord clamper	1			
80.	R50 399 224	Cord clip	5			
81.	H00 000 349	PT screw 4×8	1			
82.	Y55 001 217	Transformer	1	▲		
83.	H00 013 076	Lock washer	3			
84.	H00 011 008	PT screw 4×8 (BS)	3		For earth	
85.	Y55 009 367	Wiring diagram	1			
86.	R50 429 693	Cover	1			
87.	R50 430 693	Side plate	1			
88.	R50 351 225	Bush	4			
89.	R50 472 715	Damper	1			
90.	M31 234 089	Special bush	2			
91.	R50 429 701	Terminal fix plate	1			
92.	M13 100 242	Terminal	1	▲	3P	
93.	H00 000 007	PPT screw 4×25	1			
94.	Y55 007 235	Capacitor	1	▲	4μF·440VAC	
95.	H00 000 332	PTT screw 4×10	2			
96.	Y55 003 235	Capacitor	1	▲	4μF·440VAC	
97.	R50 429 695	PCB fix plate	1			
98.	R50 327 730	PCB fix plate	1			
99.	Y55 007 171	Circuit board	1	▲	FU-M04-D4	
100.	Y55 001 698	Separator	1			
101.	Y55 001 699	Separator	1			

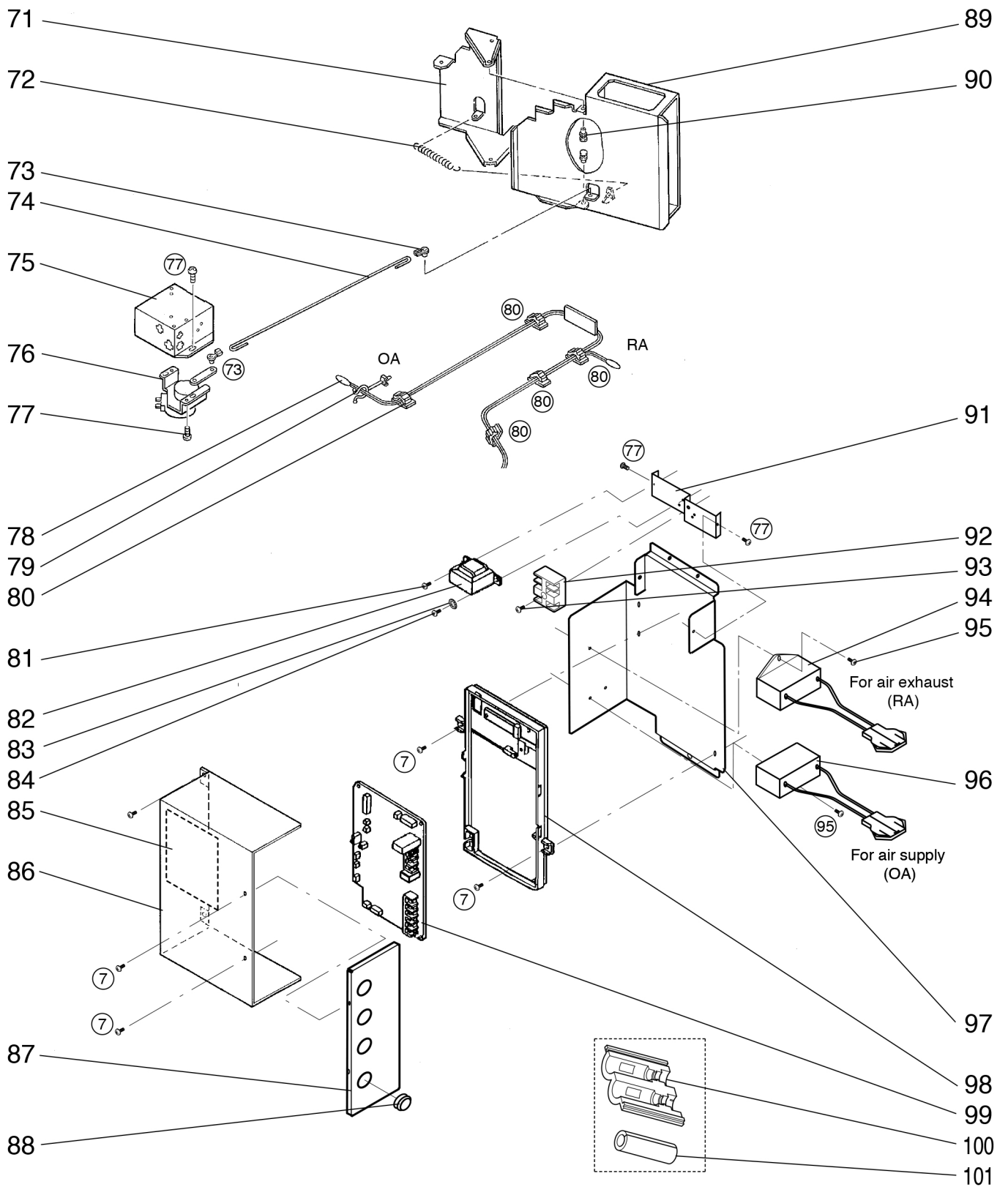

Model GUF-100RD3

No.	Parts No.	Name of part	Q'ty pcs/unit	Critical for safety	Remarks	Price
1.	Y50 063 718	Filter	2	▲		
2.	H00 000 488	PTT screw 4×12	2			
3.	R50 219 381	Core guide	1			
4.	R50 219 710	Lossnay core	2	▲		
5.	R50 266 381	Core guide	1			
6.	R50 474 737	Linear expansion valve	1	▲		
7.	H00 000 487	PTT screw 4×8	76			
8.	R50 430 609	Flange	4			
9.	R50 358 704	Cover	2			
10.	R50 466 344	Hinge	1			
11.	Y50 029 712	Fix plate	2			
12.	R50 054 383	Hanger	4			
13.	H00 000 244	PT screw 6×12	8			
14.	M34 074 017	Special screw 4×11	1			
15.	R50 430 691	Cover(L)	1			
16.	X50 004 707	Maintenance cover	1			
17.	Y55 010 366	Model name	1			
18.	H00 189 007	PTT screw 5×10	16			
19.	R50 430 692	Cover(S)	1			
20.	R50 430 694	Humidifier cover	1			
21.	R50 429 700	Fix plate	1			
22.	R50 430 695	Fix plate	1			
23.	R40 647 340	Thermistor	1	▲	Liquid pipe	
23.	R40 632 936	Thermistor	1	▲	Gas pipe	
24.	R50 430 486	Humidifier cover(IN)	1			
25.	R50 117 708	Water sensor	2	▲		
26.	M35 282 045	Special screw 4×12	1			
27.	H00 260 045	PPT screw 4×8	5			
28.	Y55 007 692	Water sensor plate	1			
29.	R50 473 699	Heat exchanger	1	▲	Refrigerant	

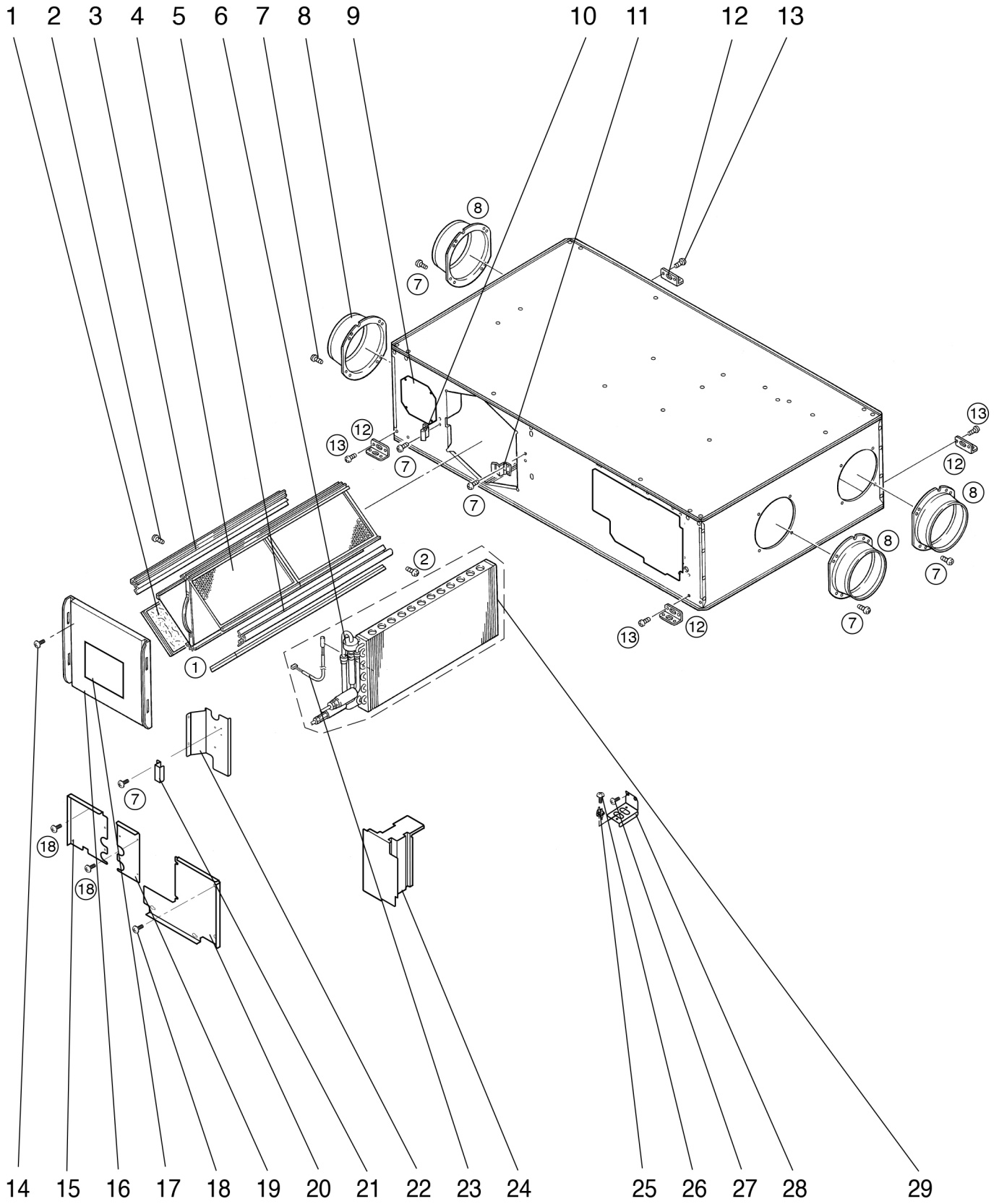

Model GUF-100RD3

No.	Parts No.	Name of part	Q'ty pcs/unit	Critical for safety	Remarks	Price
51.	R50 218 067	Special nut (12)	2			
52.	K83 466 113	Special washer (12)	2			
53.	R50 479 480	Centrifugal fan	2	▲	φ 245	
54.	R50 480 707	Fan base	2			
55.	H00 189 007	PTT screw 5×10	16			
56.	R50 264 711	Inlet plate	2			
57.	H00 157 008	PT screw 6×20	8			
58.	M34 043 080	Special washer	8			
59.	R50 000 095	Spacer	8			
60.	R50 217 225	Bush	8			
61.	R50 218 712	Motor fix leg	2			
62.	Y50 033 104	Key	1		5×5×11.5	
63.	Y50 063 452	Motor	1	▲		
64.	H00 061 050	Nut (6)	8			
65.	K83 195 080	Special washer	1			
66.	Y55 004 451	Motor	1	▲		

51 52 53 54 55 56 57 58 59 60 61 62 63 64

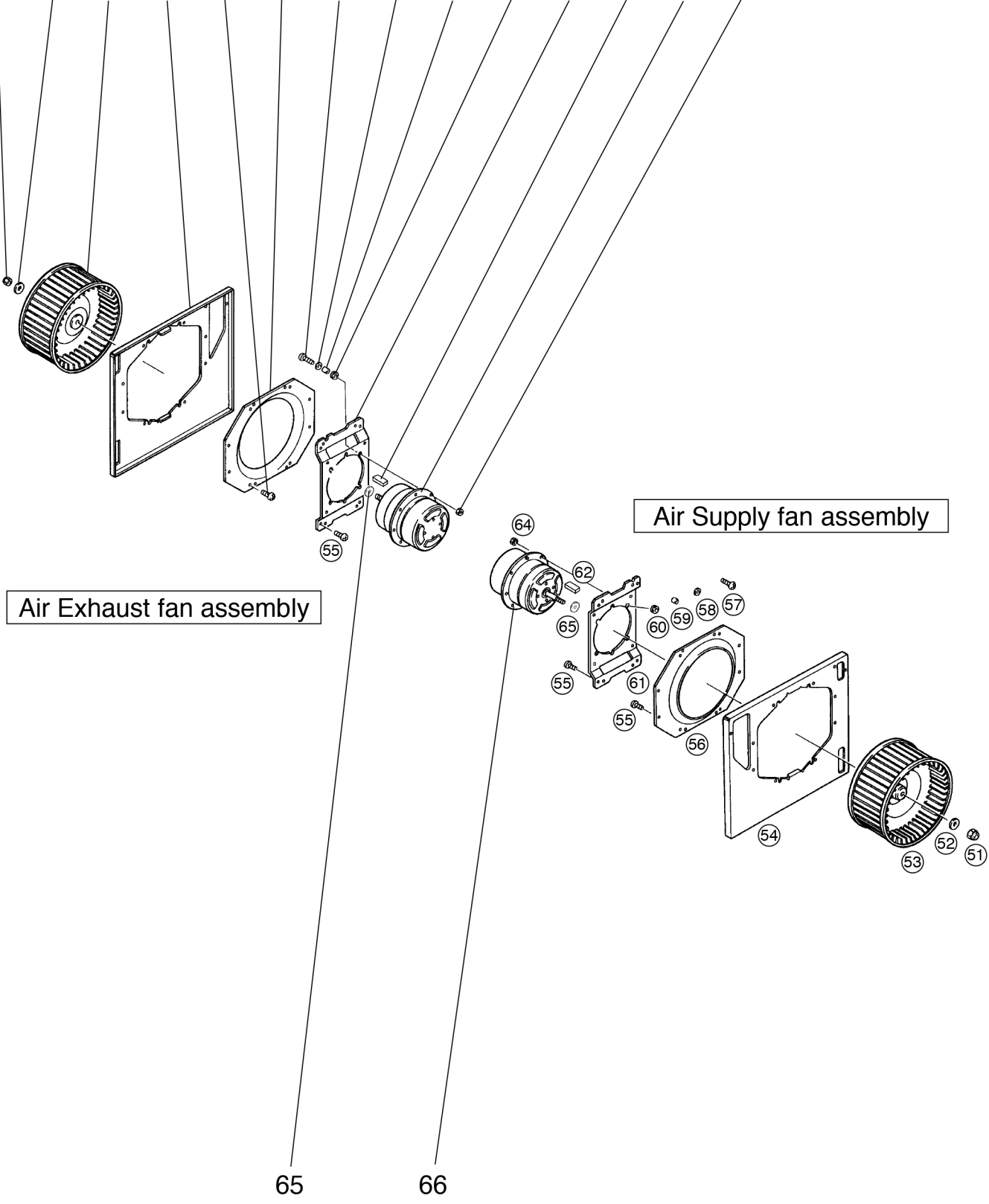

Air Exhaust fan assembly

Air Supply fan assembly

Model GUF-100RD3

No.	Parts No.	Name of part	Q'ty pcs/unit	Critical for safety	Remarks	Price
71.	R50 473 715	Damper support	1			
72.	R50 074 156	Pull spring	1			
73.	R50 054 225	Bush	2			
74.	R50 265 150	Rod	1			
75.	Y50 061 693	Damper motor cover	1			
76.	Y50 061 260	Damper motor	1	▲	220×240V	
77.	H00 312 007	PTT screw 4×6	2			
78.	Y55 004 215	Thermistor	1	▲		
79.	D41 093 224	Cord clamper	2			
80.	R50 399 224	Cord clip	7			
81.	H00 000 349	PT screw 4×8	1			
82.	Y55 001 217	Transformer	1	▲		
83.	H00 013 076	Lock washer	3			
84.	H00 011 008	PT screw 4×8 (BS)	3		For earth	
85.	Y55 009 367	Wiring diagram	1			
86.	R50 429 693	Cover	1			
87.	R50 430 693	Side plate	1			
88.	R50 351 225	Bush	4			
89.	R50 473 716	Damper	1			
90.	M31 234 089	Special bush	2			
91.	R50 429 701	Terminal fix plate	1			
92.	M13 100 242	Terminal	1	▲	3P	
93.	H00 000 007	PPT screw 4×25	1			
94.	H00 000 332	PTT screw 4×10	3			
95.	Y55 008 235	Capacitor	1	▲	7μF·440VAC	
96.	R50 429 695	PCB fix plate	1			
97.	Y55 008 236	Capacitor (2)	1	▲	4.5μF·440VAC	
98.	R50 327 730	PCB fix plate	1			
99.	Y55 007 171	Circuit board	1	▲	FU-M04-D4	
100.	Y55 001 698	Separator	1			
101.	Y55 001 699	Separator	1			

