

2-BRANCH JOINT PIPE (CMY-Y102S-G2, CMY-Y102L-G2, CMY-Y202-G2, CMY-Y302-G2)

INSTALLATION MANUAL

Caution The incorrect selection of the type of branch pipe and the size of connecting pipe does not allow the air conditioner to provide the rated capacity. Please read this instruction manual carefully for correct mounting work.

1] The following parts are contained in this box. Please identify the quantity with types.

Table with 13 columns for parts 1-13. Rows include CMY-Y102S-G2, CMY-Y102L-G2, CMY-Y202-G2, CMY-Y302-G2. Columns list part names, instructions, and quantities for various pipe types.

2] Please observe the items below for the mounting work.

- 1. Observe the restrictions on refrigerant piping length in Table-1.
2. Observe the restrictions regarding the connection of indoor units in Table-2.
3. Braze the pipes under nitrogen purge.
4. The 2-branch joint is equipped with a stopper. Push in the pipes into the branch joint until they stop.
5. Be careful that foreign materials like dust do not enter into the piping when connecting pipes.
6. Apply insulation material to all refrigerant pipings.
7. When attaching the branch joint to the gas side of the CMY-Y202-G2, CMY-Y302-G2 make sure that it is either horizontal or vertical as shown in the illustrations below. There are no restrictions on the installation of other joints.

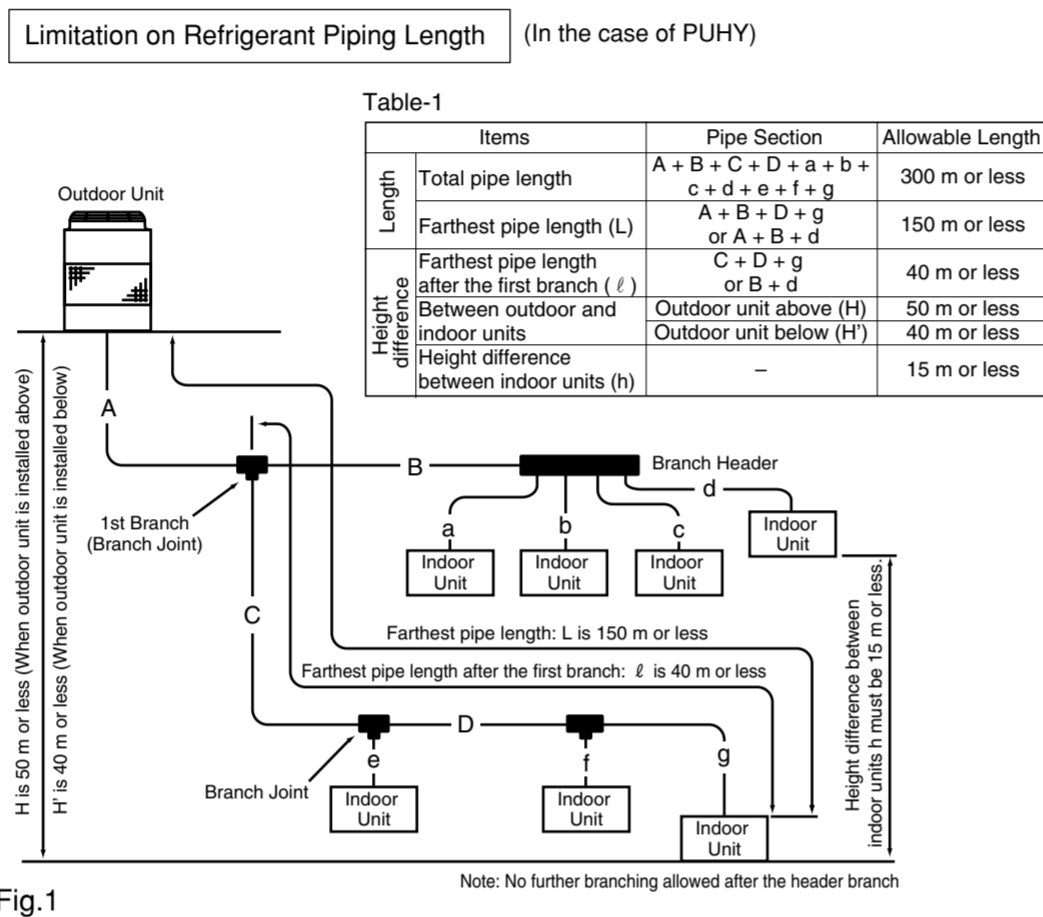

Limitation on indoor unit connection

<Example: PUHY>

Table-2 Limitation on indoor unit connection. Matrix showing compatible models and total indoor unit capacity for various outdoor unit models.

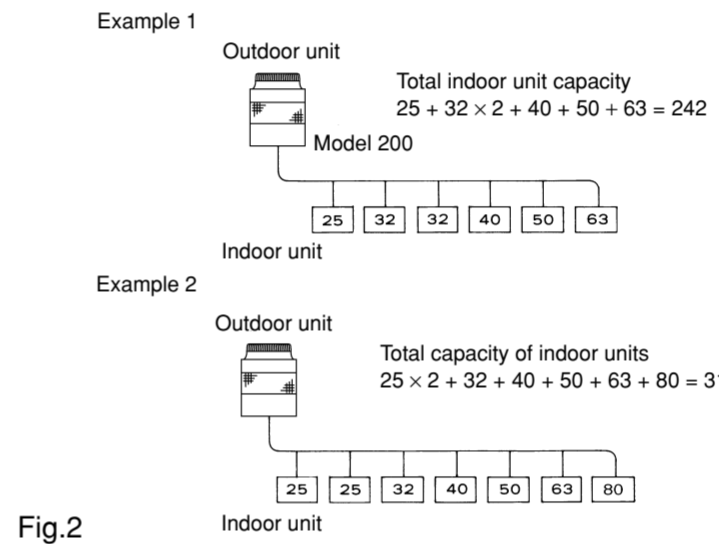

3] Selection of refrigerant piping size and use of 2-branch joint.

- 1. Prepare the pipe to be connected in the field.
2. Determine the piping sizes of each part from Table-3,4 and 5.
3. The 2-branch joint can be connected to all piping sizes selected in the item 2. to match a specified piping size.
(1) use the joint as standard. (no auxiliary pipe is necessary. Direct connection available)
(2) use it by connecting the auxiliary pipe. Please conduct actual work by referring Fig.3, and Table-6~12.
4. When pipe is cut with a pipe cutter or the like, remove burr, dust and foreign materials inside the pipe, and connect the pipe.

Table-3 Piping size between outdoor unit and 1st branching (Fig. 1-A)*. Table with columns for Outdoor unit model, Liquid pipe, and Gas pipe.

Table-6 Between branching (Fig.1-C). Table with columns for Pipe types, Down stream capacity, and various dimension ranges.

Table-4 Piping size between branching (Fig. 1-B-C-D). Table with columns for Total capacity of indoor units, Liquid pipe, and Gas pipe.

Table-5 Piping size branching (Fig. 1-a-g). Table with columns for Indoor unit model, Liquid pipe, and Gas pipe.

Table-7 Between outdoor unit and 1st branching (Fig.1-A). Table with columns for Outdoor unit model and various piping dimensions.

Table-8 Between branching (Fig.1-C). Table with columns for Pipe types, Down stream capacity, and various dimension ranges.

Table-9 Between branching and indoor unit (Fig.1-e-f). Table with columns for Pipe types, Indoor unit model, and various piping dimensions.

Table-10 Between branching (Fig.1-D). Table with columns for Pipe types, Down stream capacity, and various dimension ranges.

Table-11 Between branching and indoor unit (Fig.1-g). Table with columns for Pipe types, Indoor unit model, and various piping dimensions.

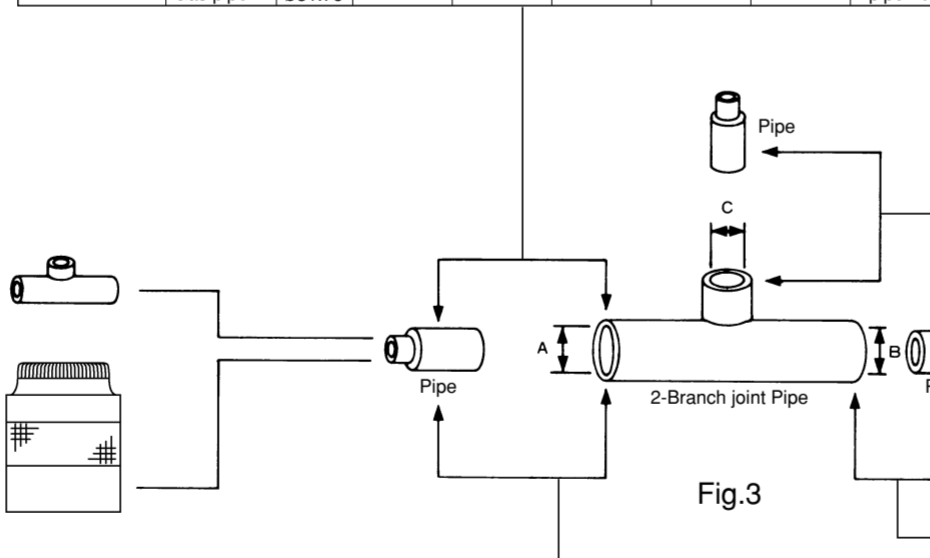

4] Installing the cover (insulation material)

Fig.4 (Example for liquid line)

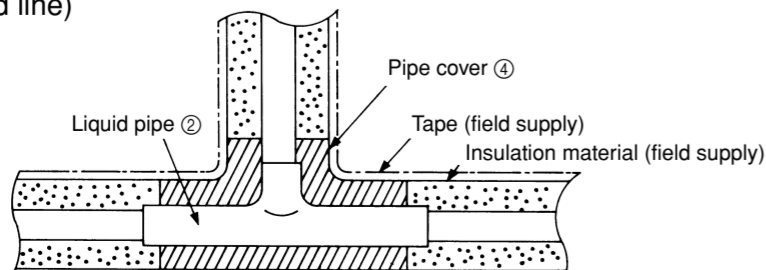

- Install the pipe cover along the liquid pipe.
Seal the joint section of pipe cover with insulated sealing tape (field supply). (Refer to Fig.4.)
• Apply the same procedures to the gas pipe also.

Fig.5

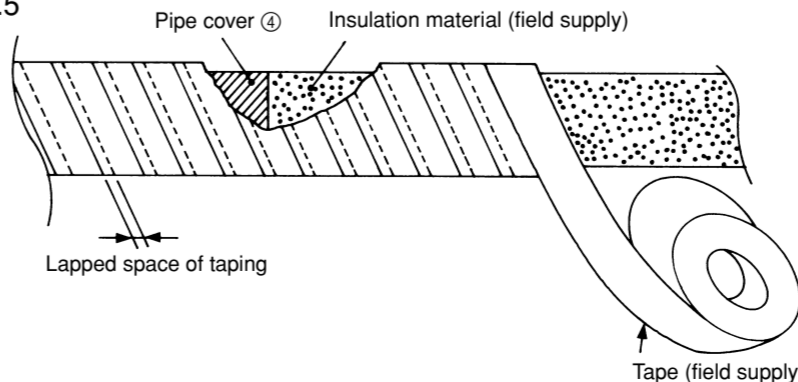

- Note 1. Apply insulation to all refrigerant piping (field supply). When using a commercially available insulation material, make sure to use the heat-resistant insulation material (heat resistant 120 °C minimum).
Note 2. The insulation cover shrinks slightly, so wrap the pipe cover and the field-installed insulation material securely with tape by overlapping the tape as shown in Fig. 5.