



A Group Company of MITSUBISHI ELECTRIC

GENERAL MANUAL FOR INSTALLATION

“Translation of the original instructions”

C0210101-04-15-EN

EN

*The information contained in this document may be modified without prior notice.
No part of this document may be reproduced and/or disclosed to third parties or competitors.*

Contents

1	DOCUMENTATION	3
2	GUARANTEE	3
2.1	Summary of the terms of the guarantee.....	3
2.2	Receipt of the unit.....	3
2.3	Performance of Climaveneta units.....	3
2.4	Manual reset of the alarms.....	3
2.5	Useful life.....	3
3	SAFETY REGULATIONS	4
3.1	Foreword.....	4
3.2	Definitions.....	4
3.3	Access to the unit.....	4
3.4	Precautions against residual risks.....	4
3.5	General precautions.....	6
3.6	Environmental information.....	6
4	POSITIONING	7
4.1	Handling, lifting and positioning the unit.....	7
4.2	Clearance.....	8
4.3	Checking that compressors are secured in position.....	8
4.4	Place of installation.....	8
5	HYDRAULIC CONNECTIONS	9
5.1	Evaporator / recuperator.....	10
5.2	Evaporator / recuperator hydraulic circuit diagram.....	11
6	CONNECTION OF THE COOLING CIRCUITS	11
7	ELECTRICAL CONNECTIONS	12
7.1	Electricity supply.....	12
7.2	POWER CONNECTIONS.....	12
7.3	Control circuit interlocking.....	12
7.4	INPUT VOLTAGE PHASE DIFFERENCE.....	13
7.5	Phase sequence checks for units with scroll compressors.....	13
8	GAS SUPPLY CONNECTIONS	13
8.1	SUPPLY SPECIFICATIONS.....	13
8.2	GAS SUPPLY LAYOUT.....	14
9	AIR CONNECTIONS (TO THE AIR DISTRIBUTION DUCTS)	14
9.1	With roof curb.....	14
9.2	Without roof curb.....	14
10	OBLIGATORY CHECKS FOR INITIAL START-UP	14
11	COMMISSIONING AND ADJUSTMENTS	14
12	MAINTENANCE	15
12.1	Precautions that must be taken during maintenance.....	15
12.2	Description of operations.....	16
12.3	Cleaning the finned coils.....	19
12.3.1	Procedure for cleaning Cu-Al "tube and fin" coils.....	19
12.3.2	Procedure for cleaning coated Cu-Al "tube and fin" coils.....	20
12.3.3	Procedure for cleaning "bare" micro-channel coils.....	20
12.3.4	Procedure for cleaning "e-coated" micro-channel coils.....	21
13	RECOMMENDED SPARE PARTS	22
13.1	1 year.....	22
13.2	2 years.....	22
13.3	5 years.....	23
14	DECOMMISSIONING AND DISPOSAL OF THE COMPONENTS AND MACHINE	23

1 DOCUMENTATION

In addition to this manual, the following documents are delivered with the unit:

- declaration of conformity
- technical bulletin
- dimensional and lifting drawings
- cooling circuit/hydraulic diagrams
- wiring diagrams
- manual of the electronic controller
- maintenance handbook

Before carrying out any operation, make sure that you have read and understand all the documents in the list.

2 GUARANTEE

2.1 Summary of the terms of the guarantee

The equipment supplied by Climaveneta is guaranteed for 12 months from the date of initial start-up but not more than 18 months from the date of invoicing. Date of initial start-up is considered as that on the appropriate "Start-up Form" contained in the "Machine maintenance logbook" fully filled in and promptly sent to Climaveneta.

The guarantee is valid only if the installation regulations (not only those issued by Climaveneta but also those dictated by current practice) have been respected, and if the "Start-up Form" has been fully filled in and sent to Climaveneta, for the attention of the After-Sales Service.

The guarantee covers flaws and defects reported within eight days of their being found. Furthermore, the guarantee will hold only on the condition that the client suspends using the equipment as soon as a defect is detected.

The guarantee is considered valid only if the initial start-up was carried out by an authorised Service Centre.

The guarantee is valid if regular maintenance of the equipment has been properly recorded in the "Machine maintenance logbook" located inside the control panel.

The guarantee covers replacement of parts which are found to be faulty.

Climaveneta shall not be liable for any costs of handling on the site (i.e., for cranes, dismantling pipes, etc. ...) required to replace instruments such as compressors, heat exchangers, fans, etc. ..., nor for travel and accommodation for technicians for operations in the place of installation.

2.2 Receipt of the unit

When the unit is received the client must check that there is no evident damage and no parts are missing. Otherwise, a claim for damages or non-delivery must immediately be sent to the shipper, reporting conditional acceptance on the bill. If the damage is conspicuous, a photographic record must also be forwarded.

2.3 Performance of Climaveneta units

Climaveneta units are factory tested according to strict internal procedures. Performance tests can only be carried out on the system if the same conditions found in the test rooms are reproduced and maintained (the same constant load, temperature and flow rates to the heat exchangers).

2.4 Manual reset of the alarms

Warn a technician of any alarm that may have appeared on the unit. **If an alarm should go off, the unit must not be reset manually until the cause has been checked out and removed. Repeated manual resets can render the guarantee null and void.**

2.5 Useful life

In normal operating conditions, the unit is expected to have a lifetime of 10 years if it is properly serviced as described in chapter 9. After that period, the unit should be overhauled by technicians authorised by Climaveneta.

3 SAFETY REGULATIONS

3.1 Foreword

This product is a complex machine. During installation, operation, maintenance and repairs, people and objects might be exposed to risks associated with certain conditions or components such as, but not limited to: refrigerant, oils, moving mechanical parts, pressure, heat sources, electrical power. Each of these elements might result in damage to objects and possibly serious personal injury or even death. The people who operate the product have the obligation and responsibility to identify and recognise dangers and to protect themselves and always proceed in safety.

This product and the relative documents, including this manual, are intended for people who have received independent training and have been taught how to work in a correct and safe manner. Before handling this equipment in any way, it is essential that the personnel involved have read and understand all the manuals and all the other reference material. The personnel must also be familiar with and observe the standards that apply to the work in hand.

Climaveneta S.p.A. and its TECHNICIANS (as described in this manual) decline all responsibility for non-compliance with safety regulations that were in force at the moment of installation.

3.2 Definitions

- **Owner:** Legal representative of the company, a body, or a natural person who owns the plant where the Climaveneta unit is installed and is responsible for checking compliance with all the safety rules in this manual and the national regulations in force.
- **Installer:** Legal representative of the firm that the owner has put in charge of positioning and connecting hydraulically, electrically, etc. the Climaveneta unit to the plant: he/she is responsible for the handling and correct installation in conformity with what is indicated in this manual and the national regulations in force.
- **Operator:** Any natural or legal person who has effective control over the technical operation of the equipment and air-conditioning systems. A member state of the European Community can, in very specific circumstances, consider the owner responsible for the obligations of the operator.
- **Maintenance person:** The person authorised by the owner to carry out on the Climaveneta unit all operations of regulation and checking expressly indicated in this manual, and which must be strictly followed. His/her work will be limited only to what is clearly allowed.
- **Technician:** The person authorised directly by Climaveneta to carry out all operations of ordinary and extraordinary maintenance. He/she will also carry out all regulations, checks, repairs and replacement of parts that should become necessary during the life of the unit itself. Outside Italy and those countries where Climaveneta and its subsidiary are not directly present, the Climaveneta agent is personally responsible for acquiring a suitable number of Technicians proportional to the area and to the business.

3.3 Access to the unit

The unit must be placed in an area where only the **OPERATORS, MAINTENANCE PEOPLE** and **TECHNICIANS** can gain access to it; otherwise it must be surrounded by a fence that is at least 2 metres from the external surface of the machine.

The staff of the **INSTALLER** or any other visitors must always be accompanied by an **OPERATOR**. For no reason whatsoever must non-authorized persons be left on their own with the unit.

The **MAINTENANCE MAN** must limit him/herself to the controls of the unit only; the only panel that can be opened by him/her is the one that accesses the control module - no other must be touched. The **INSTALLER** must limit him/herself to connecting the plant to the unit.

Access the unit using the relative personal protective equipment and only after having read and understood the documents and instructions, which must always be kept close at hand.

3.4 Precautions against residual risks

Prevention of residual mechanical risks

- install the unit according to the instructions set out in this manual
- regularly carry out all the maintenance operations foreseen in this manual
- wear protective equipment (gloves, eye protection, hard hat, etc.) suited to the work in hand; do not wear clothes or accessories that can get caught or sucked in by flows of air; tie back long hair before entering the unit
- before opening the machine panelling make sure that it is firmly hinged to the machine
- the fins on heat exchangers and the edges of metal components and panels can cause cuts
- do not remove the guards from mobile components while the unit is operating
- make sure that mobile component guards are fitted correctly before restarting the unit

- fans, motors and belts drives might be running: before entering, always wait for these to stop and take appropriate measures to prevent them from starting up
- the surfaces of the machine and pipes can get very hot or cold and cause the risk of scalding
- never exceed the maximum pressure limit (PS) of the water circuit of the unit indicated on the rating plate
- before removing parts on the pressurised water circuits, close the section of the piping concerned and drain the fluid gradually to stabilise the pressure at the atmospheric level
- do not use your hands to check possible refrigerant leaks.

Prevention of residual electrical risks

- disable the unit from the mains using the main switch before opening the control panel
- check that the unit has been grounded correctly before starting it
- install the machine in a suitable area; in particular, do not install it outdoors if it is intended for use indoors
- do not use cables with inadequate sections nor extension cord connections, even for very short periods or emergencies
- for units with power correction capacitors, wait 3 minutes after removing the electric power supply before accessing the inside of the switch board
- if the unit is equipped with centrifugal compressors with integrated inverter, disconnect it from the mains and wait a minimum of 15 minutes before accessing it to carry out maintenance: residual energy in the components, which takes at least this length of time to dissipate, poses the risk of electrocution

Prevention of other residual risks

- the unit contains pressurised refrigerant gas: the pressurised equipment must not be touched except during maintenance, which must be entrusted to qualified and authorised personnel
- connect up the utilities to the unit following the indications set out in this manual and on the panelling of the unit itself
- the water circuit contains harmful substances. Do not drink from the hydraulic circuit and make sure the material contained in it does not touch your skin, eyes or clothing.
- In order to avoid an environmental risk, make sure that any leaking fluid is collected in suitable devices in accordance with local regulations.
- if a part needs to be dismantled, make sure it is correctly re-assembled before starting the unit
- keep extinguishers near the machine that are suitable for putting out electrical fires and are suited to the lubricant oil in the compressor and the refrigerant, as indicated in the relative safety data sheets (for example, a CO2 extinguisher)
- the unit is equipped with pressure relief valves (safety valves): when these valves are triggered, the refrigerant gas is released at a high temperature and speed; prevent the release of gas from harming people or objects and, if necessary, discharge the gas according to the provisions of EN 378-3 and the local regulations in force, making sure in particular to discharge fluids that belong to a safety class other than A1 into safe, open areas (see Tab.3)
- keep all the safety devices in good working order and check them periodically according to the regulations in force
- keep all lubricants in suitably marked containers
- do not store inflammable liquids near the unit
- solder or braze only empty pipes after removing all traces of lubricant oil; do not use flames or other heat sources in the vicinity of pipes containing refrigerant fluid
- do not use naked flames near the unit
- the machinery must be installed in structures protected against atmospheric discharge according to the applicable laws and technical standards
- do not bend or hit pipes containing pressurised fluids
- it is not permitted to walk or rest other objects on the machines
- the user is responsible for overall evaluation of the risk of fire in the place of installation (for example, calculation of the fire load)
- during transport, always secure the unit to the bed of the vehicle to prevent it from moving about and overturning
- the machine must be transported according to the regulations in force taking into account the characteristics of the fluids in the machine and the description of these on the safety data sheet
- inappropriate transport can cause damage to the machine and even leaking of the refrigerant fluid. Before start-up, the machine must be checked for leaks and repaired accordingly.

- the accidental discharge of refrigerant in a closed area can cause a lack of oxygen and, therefore, the risk of asphyxiation: install the machinery in a well ventilated environment according to EN 378-3 and the local regulations in force.
- the installation must comply with the requirements of EN 378-3 and the local regulations in force; in the case of installations indoors, good ventilation must be guaranteed and refrigerant detectors must be fitted when necessary.
- unless arranged otherwise with Climaveneta, the machine be installed in environments where there is no risk of explosion (SAFE AREA)

3.5 General precautions

- during storage and transport, keep the machine within the following temperature ranges in relation to the refrigerant inside (wider ranges are possible and must be requested when ordering):

	R134a	R410A	R404A	R407C	HFO-1234ze(E)
T min (°C)	-10	-10	-10	-10	-10
T max (°C)	55	46	45	46	55

Tab.1

- prevent the fluids in contact with the heat exchangers from exceeding the temperature ranges indicated above and from freezing, even when the unit is turned off.
- do not bring in contact with the heat exchangers any fluids other than water or water mixed with ethylene/propylene glycol at a maximum concentration of 50%
- the machine must only be put to the use for which it was designed; any other uses can be dangerous and will render the guarantee null and void
- carrying out maintenance on the product can be dangerous: in the event of a fault or malfunctioning, please contact an authorised assistance centre
- the installation must guarantee that the temperature of the fluid entering the unit remains stable and within the range indicated; be careful, therefore, when adjusting any external heat exchanging and control equipment (dry coolers, cooling towers, zone valves, etc.), sizing the mass of fluid circulating the plant (particularly when parts of the plant are excluded) and installing systems for circulating the required amount of fluid, in order to keep the temperature of the machine within the allowable ranges (e.g. during start-up).
- the packaging used to protect the machine must always be kept out of the reach of children as it represents a hazard
- in units with compressors in parallel, do not disable the individual compressors for long periods of time; always respect the demand limit function

3.6 Environmental information

The cooling circuit contains fluorinated greenhouse gas covered by the Kyoto Protocol. The units may only be serviced and disposed of by qualified technicians.

The fluorinated greenhouse gases contained in the cooling circuit must not be disposed of in the atmosphere.

	R134a	R410A	R404A	R407C	HFO-1234ze(E)
GWP ₁₀₀	1300	1975	3784	1653	6

Tab.2

4 POSITIONING

4.1 Handling, lifting and positioning the unit

Before handling the unit, read with care the following instructions, the information on the yellow label on the product and in the dimensional drawing, and the instruction manual of the lifting equipment used.

Handling and transport must be carried out by qualified personnel using suitable personal protective equipment and materials suited to the weight and size of the unit.

The units can be lifted using either tubular rods or eye-bolts. Follow the procedure below:

- Handle the unit at an ambient temperature above -10°C and when there is no wind
- Make sure that all the panels and connections (bolts, rivets, etc.) are not damaged and are fastened and secured correctly
- Use all, and only, the lifting points indicated in the dimensional drawing and marked on the unit
- Use cables of suitable load-bearing capacity and length, as indicated in the dimensional drawing.
- Make sure that the cables are securely fastened to the unit:

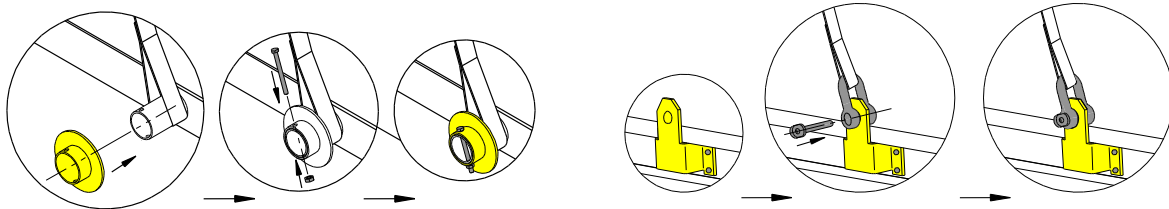
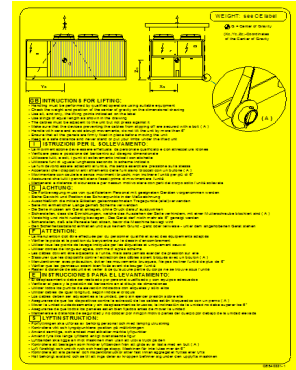

- It is obligatory to use a sling bar of suitable weight-bearing capacity to guarantee stability when lifting and to prevent the cables from coming in contact with the unit

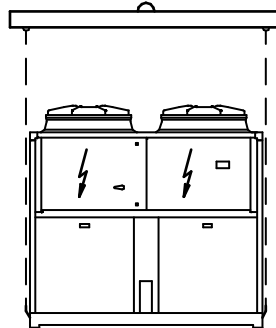

- Handle the unit carefully without making sudden movements or tilting the unit at an angle of more than 6° .
- Keep at a safe distance and do not, for any reason, stand with parts of the body under or near the lifted unit

The surface on which the unit is placed must be level and sufficiently strong to take the weight of the machine when it is full of water and running.

To reduce vibrations to the supporting structures, assemble vibration dampers at each fastening point indicated in the dimensional drawing. Install the vibration dampers under the base with the unit lifted no more than 200 mm off the ground and avoid standing with parts of the body under the unit.

In any case, always secure the unit on the ground.

4.2 Clearance

Observe the clearances indicated in the dimensional drawing

Caution:

- When two units are set side by side on the battery side, add up the measurements to be respected on the battery side of the two units.
- When the unit is in its final position and full of water, adjust the jacks of the vibration dampers.

4.3 Checking that compressors are secured in position

When the compressors are installed on spring vibration dampers, remove the block before start-up observing the instructions in the vicinity of the compressor.

4.4 Place of installation

The unit must be installed according to the requirements of standard EN 378-3 and the local regulations in force, in particular taking into account the category of occupation of the premises and the safety class defined by EN 378-1

	R134a	R410A	R404A	R407C	HFO-1234ze(E)
safety class	A1	A1	A1	A1	A2

Tab.3

The air-cooled machines must be protected against wind: because wind can affect control of cooling and prevent defrosting in the heat pumps. The finned coils must also be protected against dirt (dust, leaves, wood chips, etc.) and atmospheric conditions that can cause corrosion.

5 HYDRAULIC CONNECTIONS

The connection pipes must be suitably supported so that they do not weigh down on the unit. Avoid rigid connections between the machine and the pipes, and install vibration dampers.

For temperatures, minimum and maximum water flow rates and the content of water in the heat exchanger hydraulic circuit refer to the unit bulletin or ask the supplier. These indications must be respected both when the unit is working and when it is switched off.

Protect the hydraulic circuit with an anti-freeze mix when the room temperature can drop below zero or eliminate all the water in the exchangers and in the lowest points of the hydraulic circuit.

Any heating elements installed to prevent the pipes from freezing must be kept away from devices, sensors and materials that the heating elements could damage or cause to malfunction (for example, temperature sensors, plastic components and power cables).

The temperature of the fluid at the machine outlet must always respect, even during the start-up phase, the work field envisaged by the manufacturer. For that purpose a by-pass valve and/or other system devices can be inserted on the hydraulic circuit.

The water system of the units must be designed in such a way as to guarantee that, in all working conditions, the fluid circulating in the primary circuit remains within the minimum limit set down in the technical bulletin of the unit.

If the unit is not equipped with a device for controlling the flow of vector fluid, it is necessary to guarantee that this is kept constant.

The vector fluid must never flow backwards in the water circuits. This could damage the pumps and cause bypassing, compromising the capacity and temperature of the plant.

When several machines are installed in parallel:

- prevent the back-flow of vector fluid, particularly when the machines are turned off; one way to do this is to fit non-return valves or other suitable devices on the water circuit, specifically on the delivery side of the pumps or machines; units fitted with several separate pumps in parallel have check valves on the delivery side of the pumps for this reason, but it is important to check that this is not the case for twin pumps
- reduce the overall flow and shut off the flow to machines that are turned off in order to prevent mixing of fluids at different temperatures that can affect performance and the operating limits

Check that the water contained in the hydraulic circuit respects the following characteristics for the whole lifetime of the system:

	Description	Symbol	Value
1	Concentration of hydrogen ions	pH	7.5 ÷ 9
2	Presence of calcium (Ca) and magnesium (Mg)	Hardness	4 ÷ 8.5 °D
3	Chloride ions	Cl ⁻	< 150 ppm
4	Iron ions	Fe ³⁺	< 0.5 ppm
5	Manganese ions	Mn ²⁺	< 0.05 ppm
6	Carbon dioxide	CO ₂	< 10 ppm
7	Hydrogen sulphide	H ₂ S	< 50 ppb
8	Oxygen	O ₂	< 0.1 ppm
9	Chlorine	Cl ₂	< 0.5 ppm
10	Ammonia	NH ₃	< 0.5 ppm
11	ratio between carbonates and sulphates	HCO ₃ ⁻ / SO ₄ ²⁻	> 1

Tab.4

where: $1/1.78 \text{ °D} = 1 \text{ °Fr}$ with $1 \text{ °Fr} = 10 \text{ gr CaCO}_3 / \text{m}^3$
 ppm = parts per million; ppb = parts per billion

Explanatory notes

- ref. 1: A greater concentration of hydrogen ions (pH) than 9 implies a high risk of deposits, whereas a lower pH than 7 implies a high risk of corrosion
- ref. 2: The hardness measures the amount of Ca and Mg carbonate dissolved in the water with a temperature lower than 100°C (temporary hardness).
A high hardness implies a high risk of deposits.
- ref. 3: The concentration of chloride ions with higher values than those indicated causes corrosion
- ref. 4 - 5 - 8: The presence of iron and manganese ions and oxygen leads to corrosion
- ref. 6 - 7: Carbon dioxide and hydrogen sulphide are impurities that promote corrosion
- ref. 9: Usually in water from the waterworks it is a value of between 0.2 and 0.3 ppm. High values cause corrosion
- ref. 10: The presence of ammonia reinforces the oxidising power of oxygen
- ref. 11: Below the value shown in the table, there is a risk of corrosion due to the trigger of galvanic currents between copper and other less noble metals.

In the case of service fluids other than water (e.g. ethylene or propylene glycol), it is advisable to always use fluids containing special inhibitors that offer thermal stability within the operating temperature ranges and protection against corrosion phenomena.

It is absolutely essential that, in the presence of dirty and/or aggressive water, an intermediate heat exchanger is placed upstream of the refrigeration system heat exchangers.

5.1 Evaporator / recuperator

The following must be installed on the heat exchanger hydraulic circuit taking care to respect the correct positioning (see Fig. 1):

- Two pressure gauges with a suitable range (inlet - outlet).
- Two service cocks for the pressure gauges.
- Air bleed valves to be fitted to the highest points of the circuit.
- Two vibration damping joints (inlet - outlet) positioned horizontally.
- One flow switch to be fitted at the unit outlet in a linear stretch of a length of about 7 times the diameter of the pipe itself. The flow switch must be calibrated so as to guarantee a minimum water flow to the heat exchangers, not less than the value indicated in the unit bulletin or declared by the supplier. If this value is not available, calibrate the flow switch to 70% of the rated water flow of the unit (not envisaged for desuperheaters).
- A calibration valve at the outlet.
- Two shut-off valves (inlet - outlet).
- A mechanical filter with a maximum mesh size of 1 mm to be fitted as near as possible (maximum distance 2 metres) to the heat exchanger inlet
- A drain cock to be fitted in the lowest point of the hydraulic system.
- A circulation pump.
- All other equipment listed in Fig. 1
- There must also be no air in the water circuit, the pressure must not be lower than atmospheric pressure at any point and the water flow rate must not be subject to changes higher than 10% per minute but kept constant during operation: for this reason it is advisable to install an independent pump unit for each single evaporator with a circuit separate from the rest of the system.

For the production of domestic water it is recommended to install an intermediate exchanger to prevent dirt, corrosion and pollution of the water from any oxides.

Type Q and type R multi-purpose machines are for 4 pipe systems whose hydraulic circuits must always be able to have circulating water.

The directions for installation set out above represent a necessary condition for the validity of the guarantee. However, Climaveneta is willing to examine any different needs, which must in any case be approved before the refrigeration system is started up.

5.2 Evaporator / recuperator hydraulic circuit diagram

Fig. 1

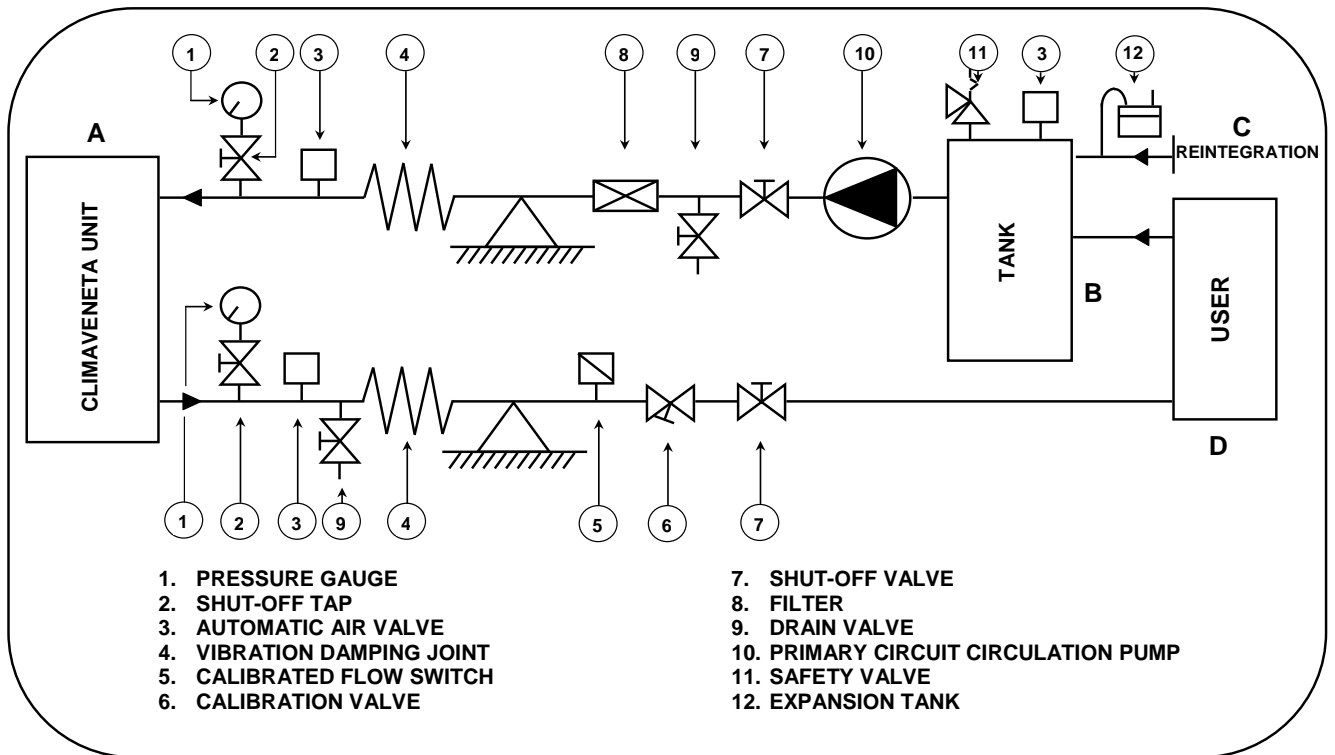

6 CONNECTION OF THE COOLING CIRCUITS

When designing and laying the cooling circuits of a two-section plant, the following must be kept in mind:

- The pipes must be positioned so that they are easily accessible for maintenance.
- The load losses of the cooling circuits reduce the efficient cooling power and increase the power absorbed by the compressor.
- Lubricating oil must return to the compressor with the same flow rate in all operating conditions, in order to guarantee correct lubrication. For this purpose, the following instructions should be complied with:
 - horizontal stretches must have a minimum slope of 0.5% in the direction of refrigerant flow;
 - in vertical stretches fit suitable oil collection wells to facilitate flow (siphon);
 - in particularly long stretches of piping fit an oil separator along the compressor delivery pipe;
- The cooling circuit must always be clean, dry and free from any kind of contaminating substance.
- Provide a liquid line with a suitable diameter in order to prevent gas from being present upstream of the thermostatic valve.
- Liquid must never be allowed to enter during compressor suction.
- Expansion of the copper piping must be appropriately calculated.
- Absorption of expansion must be guaranteed by joints or achieved with stretches of U or L bends.
- The brackets foreseen for the lines must support their weight and allow correct alignment.
- To limit propagation of vibrations, which shorten the life-span of the cooling lines and make the plant run more noisily, fit flexible joints and resilient brackets.
- The liquid line must be suitably insulated.
- Check that any liquid receiver contained in the machine is suitably large for the entire plant.
- Check that any safety devices on the machine are suitable for the whole system; fit extra safety devices if necessary.
- Use copper pipes of a thickness that is appropriate for the pressure involved.
- If two evaporators run parallel in the circuit, siphons must be used to prevent oil from collecting in the evaporator that is not in use.

- If the condenser is installed remotely from the compressor a siphon and a check valve must be fitted in the delivery line at the level of the compressor, to prevent liquid from back-flowing during shut-down.
- The condensing unit must keep the condensation pressure stable in order to allow the thermal expansion valve to work as best as possible.
- If using R134a, R407C, R404A and R410A or other refrigerants that are not compatible with mineral oils, specifically designed and tested accessories must be utilised.

The Declaration of Conformity and CE marking of the system pursuant to applicable European Community Standards and Directives shall be issued by the system manufacturer, as shall its warranty.

7 ELECTRICAL CONNECTIONS

7.1 Electricity supply

The specifications of the mains power supply must comply with EN 60204-1 and the local regulations in force and be sufficient for the absorption requirements of the unit indicated in the wiring diagram and on the data plate. Mains voltage must correspond to the rated value +/- 10% with a maximum phase difference of 2%. The unit must be connection to a three-phase TN(S) type electric power supply. Should the installation of a circuit breaker be envisaged in the electrical system, it must be type A or B.

Refer to local bylaws. Only power the system if the hydraulic circuit is charged.

7.2 POWER CONNECTIONS

Install an overload cut-out device, not included in the supply, on the supply line of the switchboard in compliance with the regulations in force.

Supply the unit switchboard with a cable of a diameter suited to the absorption capacity of the machine indicated on the data plate. The control circuit is shunted off the power circuit from inside the switchboard.

Do not touch hot and/or sharp surfaces. It is forbidden to lay electric cables in positions that have not been specifically identified.

The supply must never be disconnected, except during maintenance operations, in order to guarantee operation of the compressor crankcase heater and any anti-freeze resistances on the heat exchangers.

7.3 Control circuit interlocking

In order for the guarantee to be valid:

- **connect the calibrated flow switch to the specific terminals of the control circuit (if not included in the standard supply)**
- **connect the auxiliary pump contacts to the specific terminals of the control circuit (if present in the wiring diagram).**
- **unit input connectors (remote ON/OFF, flow switch, pumps enable, etc.) must be clean and single contacts for each unit (never make a parallel connection to more than one machine with a single enable).**

It is advisable for the connection cables of the above safety devices to be laid separately from any power cables. Otherwise, screened cables should be used. To make serial connections, use only screened cables with characteristic impedance of 120 ohm. The maximum length of the cable that connects safety devices to the farthest away unit must not exceed 1000 metres.

These devices must be connected to the first unit by a single serial cable, which then goes on to connect subsequent units. The screens of each stretch must be connected to each other but not to the unit terminal block. One of the ends of these screens must be grounded.

If the remote ON/OFF control is used, cables must be laid following the same method as the flow switch cable.

Moreover, for remote ON/OFF control from external contact or from the serial protocol control, the following minimum times must be complied with:

- Delays between 2 subsequent start-ups: 15 minutes
- Delay between shut-down and start-up: 3 minutes

Furthermore, the pump must be operated for at least 1 minute before starting the unit and be switched off 1 minute after the unit is shut down, otherwise the guarantee will be considered null and void.

7.4 INPUT VOLTAGE PHASE DIFFERENCE

Do not operate the electric motors when the voltage phase difference is greater than 2%. Use the following formula to check:

$$\% \text{ difference} = \frac{\text{Max voltage difference from the average}}{\text{average voltage}} \times 100$$

Example: Rated mains voltage 400 - 3 - 50

AB = 409 V; BC = 398 V; AC 396 V

average voltage = $(409 + 398 + 396) / 3 = 401 \text{ V}$

$$\text{difference \%} = \frac{(409 - 401)}{401} \times 100 = 1,99$$

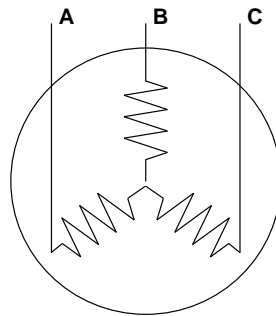

IMPORTANT:

If the mains voltage has a phase difference greater than 2%, contact the electricity company. If the unit is operated with a voltage phase difference of more than 2% THE GUARANTEE SHALL BE CONSIDERED NULL AND VOID.

Before starting up the unit, it is advisable to check that electrical systems have been implemented to guarantee conformity with the Electromagnetic Compatibility Directive (2004/108/EC).

7.5 Phase sequence checks for units with scroll compressors

After starting, check that the noise level of the compressor is normal and that the inlet temperature is lower than the outlet temperature. If not, invert a phase.

NOTE: some compressors are fitted with a phase sequence control device that displays “overload alarm” if the phases are inverted.

8 GAS SUPPLY CONNECTIONS

The rated net calorific value of natural gas is 8,250 kcal/Nm³ and 11,000 kcal/kg for LPG. If fuels with different calorific values are used, please get in touch with Climaveneta.

Caution:

LPG must always be supplied as a vapour.

8.1 SUPPLY SPECIFICATIONS

The gas supply must guarantee the gas flows required to power the unit correctly at a pressure lying between 20-300 mbar for units powered with natural gas and 0.7-1.4 bar for units powered with LPG.

Consult the relative “Use, installation and maintenance manual” of the Heating Module if supplied with the unit.

8.2 GAS SUPPLY LAYOUT

The supply network, both for natural gas and LPG, must comprise the following:

Fig. 2

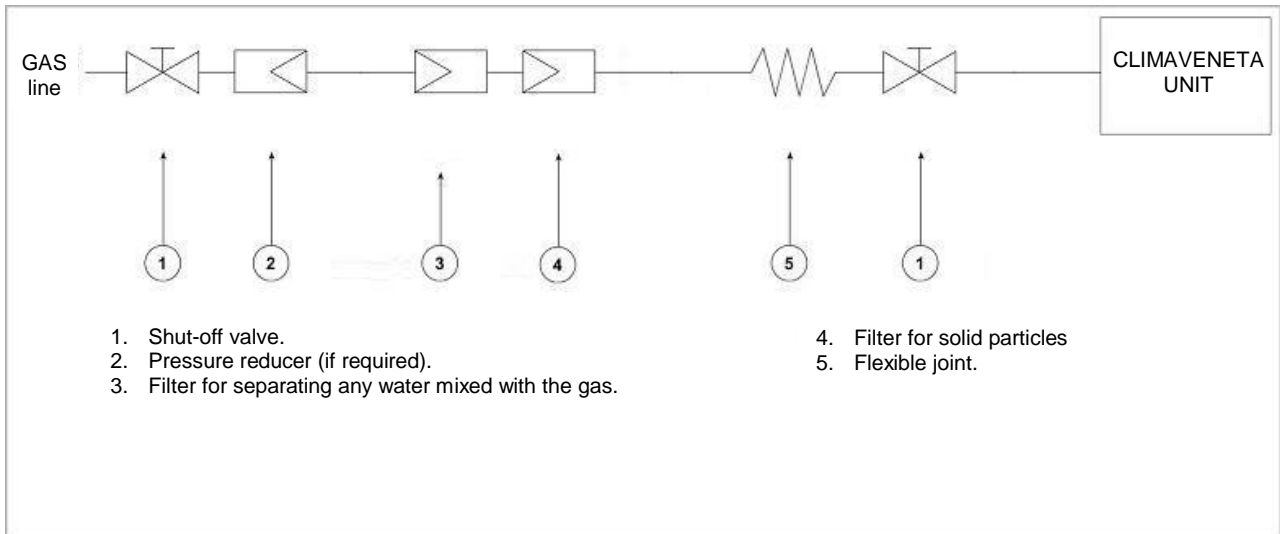

9 AIR CONNECTIONS (TO THE AIR DISTRIBUTION DUCTS)

9.1 With roof curb

Make sure that the contact surfaces between the frame and the bottom of the unit are clean and flat in order to ensure perfect connection without air escaping or humidity entering. In this case the air ducts will be connected with vibration proof gaskets to the Roof Curb flanges.

9.2 Without roof curb

If the Roof Curb is not used, connect the ducts directly to the unit with vibration-proof gaskets. The ducts must not weigh down on the flanges of the unit. The inspection panels must always be accessible for maintenance purposes.

10 OBLIGATORY CHECKS FOR INITIAL START-UP

Climaveneta tests the cooling circuit for leaks after final assembly of the unit at the production site. An additional test must be carried out before start-up to check for leaks caused by faults created during transport or installation.

Check that the product and installation comply with the local regulations. In particular, make sure that the installation and commissioning certificates have been produced and communicated.

11 COMMISSIONING AND ADJUSTMENTS

Refer to the manual of the electronic controller.

12 MAINTENANCE

Maintenance operations are fundamental to keep the refrigeration system in perfect working order, not only for purely functional reasons but also for saving energy and ensuring safety.

Each Climaveneta Unit is supplied with a Machine Maintenance Logbook in which the user or person in charge of maintenance will log the operation of the Climaveneta unit according to the prescribed schedules. Lack of records in the logbook may be considered proof of improper maintenance.

When there are no relevant standards on the use of HFO refrigerants, the Manufacturer requires application and compliance with the provisions of:

- (EC) regulation no. 842/2006, Article 3 on "containment of leaks"
 - (EC) regulation no. 1516/2007 on "standard leakage checking requirements"
- and the relative domestic laws implementing the European regulations listed above.

12.1 Precautions that must be taken during maintenance

Maintenance must be carried out only by authorised technicians. Before any kind of maintenance is carried out the following measures must be observed:

- the unit must be isolated from the electricity mains using the external main switch, suitable for the insertion of up to 3 padlocks, for locking in the "open" position;
- hang a "Maintenance - do not switch on" notice on the external main switch;
- use the appropriate personal protective equipment (hard hat, insulated gloves, protective glasses, safety footwear, etc.)
- use tools that are in good condition and be sure to be familiar with the instructions before putting them into practice.

Whenever measurements must be taken or checks performed with the machine running, it is necessary to:

- make sure that any remote control systems are disconnected; be aware that the PLC on the machine controls these and can enable and disable the components, posing a degree of danger (for example, by powering and running the fans and their mechanical systems, which can drag).
- work on the open switch board for as short a time as possible
- close the switch board as soon as the single measurement or check has been performed
- for external units, do not work on the machine in adverse weather conditions such as rain, snow, fog, etc.

Furthermore, the following precautions must always be taken:

- the cooling circuit contains pressurised gas: all maintenance must be carried out by qualified personnel with the authorisation or certification required by the laws in force
- the fluids contained in the cooling circuit must be disposed of correctly
- never keep the cooling circuit open, as the oil absorbs humidity and deteriorates
- take measures to protect yourself from any leakage of fluids at dangerous temperatures during bleeding;
- when replacing an EPROM or electronic cards, always use tools suitable for the task (extractors, anti-static bracelet, etc.)
- if replacing a motor, compressor, evaporator, condensation batteries or any other heavy component, make sure that the lifting mechanism is suitable for the weight to be lifted
- in the air units with a separate compressor compartment, do not enter the fan compartment without first having isolated the machine with the main switch on the panel and hung out a "Maintenance - do not switch on" notice
- contact Climaveneta whenever modifications must be made to the cooling circuit, hydraulic or electrical diagram of the unit, or its control logic
- contact Climaveneta whenever particularly complicated disassembly or re-assembly operations are to be performed
- always use only original spare parts purchased directly from Climaveneta or from official dealers
- contact Climaveneta whenever the unit must be moved after a year of its being positioned on the site or when dismantling becomes necessary
- make sure that all tools, electrical cables or loose objects have been removed and that the machine has been connected perfectly before closing and starting the unit again

12.2 Description of operations

	Recommended periodic maintenance interventions					
	Operation description	Frequency*				
		3/4 months	6 months	12 months	24 months	operating hours
General	Tighten the electrical connections and replace any worn or damaged cables	•				
	Check for any leaks on the cooling circuit. Perform this operation at the frequencies indicated in the relative European regulations	•				
	Check the unit power supply voltages	•				
	Check the compressor power supply voltages	•				
	Check the fan power supply voltages	•				
	Check the operation of exchanger and/or pipe anti-freeze resistances (where fitted)	•				
	Check the operation of solenoid valves	•				
	Check the operation and calibration of minimum and maximum safety pressure switches (where fitted)	•				
	Clean the safety valve drains			•		
	Replace or calibrate the operation of safety valves				•	
	Check the pressure probe reading, calibration	•				
	Check and if necessary replace dehydrator filters on the liquid line			•		
	Check the condition of the hoses	•				
	Check the wear on the compressor contacts	•				
	Check the wear on the fan contacts			•		
	Check the wear and tension of centrifugal fan transmission belts (only units with centrifugal and rooftop fans)**	•				
	Clean/replace rooftop unit filters	•				
	Clean the condensing coils (only units that are air-cooled and preferably from the inside outwards) See para. 12.3		•			
	Check the cleanliness of the shell and tube exchangers and clean them if necessary (swabbing can damage the internal scoring of the pipes: use appropriate chemical products)			•		
	Check evaporator resistance operation		•			
Check horizontal unit positioning			•			
Check the presence of rusting on the cooling circuit especially as regards pressure vessels. Apply appropriate surface protection if necessary.			•			
General unit cleaning			•			
	Vent the water circuit and heat exchangers					

	(the combination of fluid and air reduces performance and can cause corrosion)						
Cooling circuit, unit operation on full load	Measure overheating temperature value		•				
	Measure overcooling temperature value		•				
	Measure compressor discharge gas temperature value		•				
	Measure low pressure value		•				
	Measure high pressure value		•				
	Measure fan absorption, 3 phases (L1, L2, L3) or single phase where single-phase fans present		•				
	Measure compressor absorption, 3 phases (L1, L2, L3)		•				
	Measure pump absorption where fitted on the machine, 3 phases (L1, L2, L3)		•				
	Measure outdoor air temperature		•				
	Measure evaporator and condenser inlet and outlet water temperature where fitted		•				
Compressor	Check oil level	•					
	Check oil acidity			•			
	Check oil cleaning			•			
	Replace oil						Screw compressor: 8000 hours
							Scroll compressor: 12000 hours
							Piston compressor: 5000 hours
	Check correct operation of compressor oil case resistance		•				
Check dielectric rigidity			•				
Check correct operation of oil level sensor (where fitted)			•				
Hydraulic circuit	Check and calibrate correct operation of evaporator flow switch and condenser/recuperator	•					
	Check operation of water differential pressure switch	•					
	Check tightening of shell and tube exchanger heads		•				
	Check rotating seal / pump gaskets	•					
	Check concentration of glycol solution where appropriate	•					
	Check and clean water filter at water heat exchanger inlet	•					

* The frequency of the operations described in the table above should be considered indicative. In fact, it may undergo variations according to the method of use of the unit and the system in which the latter is required to operate

** The degree of tightness of the belts depends on many factors, including motor power, speed, the type and size of the belts and pulleys, etc. It is important to know the correct degree of tightness and to set it as precisely as possible. Tighten the belt as follows:

1. check alignment of the pulleys of the motor shafts and fan
2. make sure that the sides of the throat are clean
3. apply the drive belts, loosening the tensioning system in order not to damage them by stretching them too tight
4. tighten the belts by gradually adjusting the tensioning system

If there are no specific instruments for measuring belt tension, the approximate method below can be followed: To ascertain the correct tension, measure the free section T; for each belt, use a dynamometer half-way along the T to apply a perpendicular force F capable of causing a displacement of 1.5 mm for each 100 mm of T; compare the F value of the dynamometer with the values F' and F'' in the table.

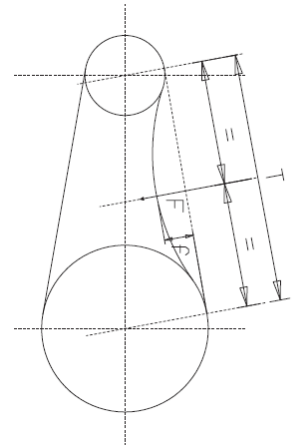

Tipo di cinghia Type of belt	Diametro puleggia minore (mm) Minor pulley diameter (mm)	Giri puleggia minore (RPM) Minor pulley speed (rpm)	Min. F' (Newton) Min. F' (Newton)	Max. F'' (Newton) Max. F'' (Newton)
SPZ	50 ÷ 90	1200 ÷ 5000	10	15
	100 ÷ 150	900 ÷ 1800	20	30
	155 ÷ 180	600 ÷ 1200	25	35
SPA	90 ÷ 145	900 ÷ 1800	25	35
	150 ÷ 195	600 ÷ 1200	30	45
	200 ÷ 250	400 ÷ 900	35	50
SPB	170 ÷ 235	900 ÷ 1800	35	45
	250 ÷ 320	600 ÷ 1500	40	60
	330 ÷ 400	400 ÷ 900	45	65
SPC	250 ÷ 320	900 ÷ 1800	70	100
	330 ÷ 400	600 ÷ 1200	80	115
	440 ÷ 520	400 ÷ 900	90	130

Tab.5

For units installed in aggressive climates, request air exchangers with a protective covering. In such climates the maintenance intervals must be reduced (to be evaluated according to the specific climatic condition).

	Periodic preventive maintenance intervals recommended on centrifugal compressors			
	Operation description	frequency		
		6 months	12 months	other
General	Check for any visible mechanical damage to the compressor	•		
	Check for any excessive vibrations caused by other mechanical components operating	•		
Checks on electrical parts	Check the power supply voltage [V] as illustrated on the compressor service manual	•		
	Check that the terminals of the power supply cables to the compressor are correctly fixed		•	
	Check for any melted or blackened points on the power cables	•		
	Check that the current value [A] is as specified in the rating plate data	•		
	Check the value of the direct current after the SCR (refer to service manual)	•		
	Check the value of the voltage [V] on the storage condensers (refer to the compressor service manual)	•		
	Replace the 4 storage condensers			every 5 years

	Check the correct operation of the safety systems (alarms)		•	
	Apply the insulating grease and lanolin as indicated in section 6.1 of the centrifugal compressor maintenance manual		•	
Checks on electrical parts	Check that all the communication cables between the compressor and its components are correctly fixed	•		
	Check that all the electronic devices are well fixed into their housing and position	•		
	Visually check that all the printed electronic cards (e.g. backplane, interface module, BMCC etc.) do not have any signs of burning or damage		•	
	Visually check that all the printed electronic cards (e.g. backplane, interface module, BMCC etc.) are not dusty or dirty at all. Otherwise clean with suitable tools		•	
	Check that the temperature and pressure sensor readings are correct; otherwise replace the component		•	
Cooling circuit check	Check that the IGV valve is operating correctly		•	
	Check the load of refrigerant in the circuit	•		
	Check the correct operation of the cooling circuit (liquid line) solenoid valves	•		
	Check/clean the compressor cooling circuit filter		•	

12.3 Cleaning the finned coils

The air exchangers (coils) must be cleaned correctly following the instructions below, in order to guarantee the best energy efficiency of the unit and to protect the product against the effects of weathering.

12.3.1 Procedure for cleaning Cu-Al "tube and fin" coils

As a minimum requirement, the coils must be inspected and cleaned on an annual basis after initial commissioning. The frequency of inspections should be increased in the case of aggressive weather conditions or a high degree of dirt.

Follow the instructions below on how to clean the coils properly:

- a. **Remove all traces of dirt on the surface.** Remove any deposits like leaves, fibres, etc. using a vacuum cleaner (or, if necessary, a brush or other soft accessory, making sure not to scratch and damage the metal parts). If using compressed air, always keep the flow of air perpendicular to the surface of the coil to avoid bending the aluminium fins. Be careful not to bend the fins with the nozzle of the compressed air gun.
- b. **Rinse.** Rinse with water. It is possible to use chemical substances (special detergents for finned coils). Rinse by letting water flow through each passage in the fins until they are perfectly clean. Always aim the jet of water perpendicularly to the surface of the coil in order to avoid bending the aluminium fins. Avoid hitting the coil with the hose. It is advisable to put a thumb on the end of the hose to adjust the pressure of the jet of water, rather than use nozzles that could knock against the coil and damage it.

Attention!

Do not use high pressure cleaners to clean the coil as excessive pressure can cause irreparable damage. Damage caused by cleaning with unsuitable chemical substances or excessive water pressure is not covered by the guarantee.

Attention!

The aluminium fins are thin and sharp. Make sure to always wear appropriate PPE to avoid cuts and abrasions. Protect the eyes and face against the spraying of water and dirt during the cleaning process. Wear waterproof shoes or boots and clothes that cover all the body.

In the case of units installed in aggressive atmosphere where there is a high degree of dirt, cleaning of the coil must be included in routine maintenance. This type of installation should in any case be cleaned on a regular basis, removing all dust and particles that settle on the coil as soon as possible and following the instructions above.

12.3.2 Procedure for cleaning coated Cu-Al "tube and fin" coils

There are various types of surface treatment for protecting Cu-Al coils. The general rules are given below. It is advisable, in any case, to always refer to the specific documentation provided by the supplier with whom we recommend establishing a maintenance contract with guarantee (Blygold and Fin Guard Silver offer this option).

As a minimum requirement, the coils must be inspected and cleaned on an **six-monthly** basis after initial commissioning. In coastal and/or industrial areas, inspections and cleaning should be carried out on a **quarterly or monthly basis**, depending on the characteristics of the place and the degree of pollution.

Routine maintenance.

Follow the instructions below on how to clean the coils properly:

- a. **Remove all traces of dirt on the surface.** Remove any deposits like leaves, fibres, etc. using a vacuum cleaner (or, if necessary, a brush or other soft accessory, making sure not to scratch and damage the metal parts). If using compressed air, always keep the flow of air perpendicular to the surface of the coil to avoid bending the aluminium fins. Be careful not to scratch the coil with the nozzle of the compressed air gun.
- b. **Rinse.** Use a low pressure jet of hot or cold water (refer to the instructions of the producer of the coating) to rinse the coil, then wash it with water mixed with the cleaning agent specified by the producer of the coating, and rinse it again.
- c. **Inspection.** After washing, always inspect the coil to check the coating for any signs of damage, deterioration and corrosion phenomena. Notify the qualified applicator immediately of any signs of damage, deterioration or corrosion on the coil.

Detergent for coated Cu-Al "tube & fin" coils.

The following detergent has been approved for use on coated coils to remove mould, dust, soot, traces of grease, fluff and other particles, providing that it is used in compliance with the manufacturer's instructions on mixing and cleaning:

Product	Retailer	Code
Blygold Coil Clean	Blygold	/

Attention!

Do not use high pressure cleaners to clean the coil as excessive pressure can cause irreparable damage. Damage caused by cleaning with unsuitable chemical substances or excessive water pressure is not covered by the guarantee.

Attention!

The aluminium fins are thin and sharp. Make sure to always wear appropriate PPE to avoid cuts and abrasions. Protect the eyes and face against the spraying of water and dirt during the cleaning process. Wear waterproof shoes or boots and clothes that cover all the body.

Supplementary maintenance.

The salient feature of the coating is the fact that it can be reapplied.

Solid particles (like sand) can enter from the side of the coil where air flows in, and erode the corrosion protection exposing the metal. Should this happen, the surface coating must be reapplied. Reapplication should be carried out by qualified personnel.

The coating can be reapplied several times during the useful life of the coil.

Normally, good routine maintenance reduces the need for supplementary maintenance.

12.3.3 Procedure for cleaning "bare" micro-channel coils

Micro-channel tube & fin coils tend to accumulate dirt more on the outside and less on the inside, and are, therefore, easier to clean.

As a minimum requirement, the coils must be inspected and cleaned on an **quarterly** basis after initial commissioning. The frequency of inspections should be increased in the case of aggressive weather conditions or a high degree of dirt.

Follow the instructions below on how to clean the coils properly:

- a. **Remove all traces of dirt on the surface.** Remove any deposits like leaves, fibres, etc. using a vacuum cleaner (or, if necessary, a brush or other soft accessory, making sure not to scratch and damage the metal parts). If using compressed air, always blow this from the inside outwards (the air should flow in the direction

opposite that during normal operation). In this case, too, be careful not to scratch the coil with the hose or nozzle of the compressed air gun.

- b. **Rinse.** Rinse only with water. Do not use chemical substances (including special detergents for finned coils). These substances can cause corrosion. Rinse preferably from the inside outwards, aiming the jet perpendicularly to the face of the coil and allowing the water to flow in each passage of the fins until these are perfectly clean. These fins are sturdier than those of conventional coils but should still be handled with care. Avoid hitting the coil with the hose. It is advisable to put a thumb on the end of the hose to adjust the pressure of the jet of water, rather than use nozzles that could knock against the coil and damage it. Gently blow out any residual water at the centre of the fins.

Attention!

Do not use high pressure cleaners to clean the coil as excessive pressure can cause irreparable damage. Damage caused by cleaning with chemical substances or excessive water pressure is not covered by the guarantee.

Attention!

Make sure to always wear appropriate PPE to avoid cuts and abrasions. Protect the eyes and face against the spraying of water and dirt during the cleaning process. Wear waterproof shoes or boots and clothes that cover all the body.

12.3.4 Procedure for cleaning "e-coated" micro-channel coils

The cleaning procedures below are recommended and should be carried out as part of routine maintenance for e-coated coils. A record of all routine cleaning of the coils must be kept in accordance with the terms and conditions of the guarantee provided by the supplier of the e-coating treatment.

Follow the instructions below on how to clean the coils properly:

- a. **Remove all traces of dirt on the surface.** Remove any deposits like leaves, fibres, etc. using a vacuum cleaner (or, if necessary, a brush or other soft accessory, making sure not to scratch and damage the metal parts). If using compressed air, blow this from the inside outwards (the air should flow in the direction opposite that during normal operation). In this case, too, be careful not to scratch the coil with the hose or nozzle of the compressed air gun.
- b. **Routine cleaning.** In coastal or industrial areas, the coil must be rinsed on a monthly basis using just water to remove chlorides, dirt and debris. It is important to use water at a temperature below 45°C and at a pressure below 40 bar to reduce surface tension and thereby facilitate the removal of dirt and chlorides without damaging the coil. Do not use chemical substances (including special detergents for finned coils). These substances can cause corrosion. Rinse preferably from the inside outwards, aiming the jet perpendicularly to the face of the coil and allowing the water to flow in each passage of the fins until these are perfectly clean. These fins are sturdier than those of conventional coils but should still be handled with care. Avoid hitting the coil with the hose. It is advisable to put a thumb on the end of the hose to adjust the pressure of the jet of water, rather than use nozzles that could knock against the coil and damage it. Gently blow out any residual water at the centre of the fins.
- c. **Quarterly cleaning.** Quarterly cleaning is required under the terms of the guarantee and can extend the useful life of the e-coated coil. Failure to perform quarterly cleaning renders the guarantee null and void and can reduce the performance and life-span of the coil. Follow the instructions below on routine quarterly cleaning:
 - I. First clean the coil using the approved type of detergent (refer to the list of approved products further on).
 - II. Next, use the approved product to remove chloride (**CHLOR * RID DTS™**). Treatment with this product eliminates soluble salts and revitalises the unit. This product must be applied directly on the salts in order for it to be effective. The salts may be under a layer of grease or dirt. It is essential, therefore, to clean the surfaces thoroughly with detergent before applying the product. Apply a sufficient amount of **CHLOR * RID DTS™** in a uniform manner all over the surface of the coil. Make sure to coat the surface thoroughly without leaving any gaps. The product can be applied using a spray pump or a standard spray gun. When the surface has been completely wetted, the salts are made soluble. Lastly, rinse the surface with water as instructed in the section "b. routine cleaning".

Approved detergent for e-coated coils.

The following detergent has been approved for use on e-coated coils to remove mould, dust, soot, traces of grease, fluff and other particles, providing that it is used in compliance with the manufacturer's instructions on mixing and cleaning:

Product	Retailer	Code
Enviro-Coil Concentrate	HYDRO-BALANCE CORPORATION	H-EC01
Enviro-Coil Concentrate	Home Depot Supply	H-EC01
EnviroCoil Cleaner	Universal Coil Advanced Engineering	/

Attention!

Do not use high pressure cleaners to clean the coil as excessive pressure can cause irreparable damage. Damage caused by cleaning with chemical substances or excessive water pressure is not covered by the guarantee.

Attention!

Make sure to always wear appropriate PPE to avoid cuts and abrasions. Protect the eyes and face against the spraying of water and dirt during the cleaning process. Wear waterproof shoes or boots and clothes that cover all the body.

13 RECOMMENDED SPARE PARTS

The list of spare parts is provided on request.

13.1 1 year

• Fuse	• all
• Dehydrator filters	• all
• Solenoid valve coils	• 1 per type
• Air filters	• all
• Water differential pressure switch	• 1 per type
• Belts	• all
• Probes	• 1 per type
• Casing resistances	• 1 per type

13.2 2 years

In addition to the 1 year list:

• Pressure switches	• all
• Safety valves	• all
• Contactors and auxiliary relays	• all
• Compressor thermal overload cut-outs	• all
• Automatic circuit breakers	• all
• Transducers	• all
• Fans	• 1 per type

13.3 5 years

In addition to the 1 year and 2 year lists:

• Solenoid valves	• all
• Thermostat valves	• all
• Pressure gauges	• all
• Compressors	• 1 per type
• Electronic components	• all
• Fans	• 50% of the number per type
• Set of condensers for centrifugal compressor	

14 DECOMMISSIONING AND DISPOSAL OF THE COMPONENTS AND MACHINE

WARNING! The unit contains fluorinated greenhouse gases covered by the Kyoto protocol. In accordance with the law, these must not be dispersed in the environment but collected and delivered to the retailer or collection centre.

When components are replaced, or when the entire unit is removed from the installation at the end of its useful life, the following requirements must be observed to minimise impact on the environment:

- the refrigerant gas must all be collected by specialist personnel with the necessary certification and delivered to the collection centres;
- the lubrication oil in the compressors and cooling circuit must be collected and delivered to the collection centres;
- the structure, the electrical and electronic equipment and the components must be sorted according to category and material and delivered to the collection centres;
- if the water circuit contains mixtures with antifreeze, these must be collected and delivered to the collection centres;
- observe the domestic laws in force.



A Group Company of **mitsubishi electric**

Climaveneta SpA

Via Sarson 57/c
36061 Bassano del Grappa (VI)
Italy
Tel +39 0424 509 500
Fax +39 0424 509 509
info@climaveneta.com
www.climaveneta.com

Subsidiaries

France
www.climaveneta.fr

Spain
www.climaveneta.es

Poland
www.climaveneta.pl

Germany
www.climaveneta.de

Great Britain
www.climaveneta.co.uk

Russia
ru.climaveneta.com
<http://ru.climaveneta.com/>

China
www.climaveneta.com.cn

India
www.climaveneta.in

Middle East
ae.climaveneta.com

Southeast Asia
www.climaveneta.com

Hong Kong
www.climaveneta.com



For more information:
www.climaveneta.com