

PARTS CATALOG

Series PLA Ceiling Cassettes

R410A

Indoor unit
[Model Name]

[Service Ref.]

PLA-RP35EA **PLA-RP35EA.UK**

PLA-RP50EA **PLA-RP50EA.UK**

PLA-RP60EA **PLA-RP60EA.UK**

PLA-RP71EA **PLA-RP71EA.UK**

PLA-RP100EA **PLA-RP100EA.UK**

PLA-RP125EA **PLA-RP125EA.UK**

PLA-RP140EA **PLA-RP140EA.UK**

Note:

- RoHS compliant products have <G> mark on the spec name plate.

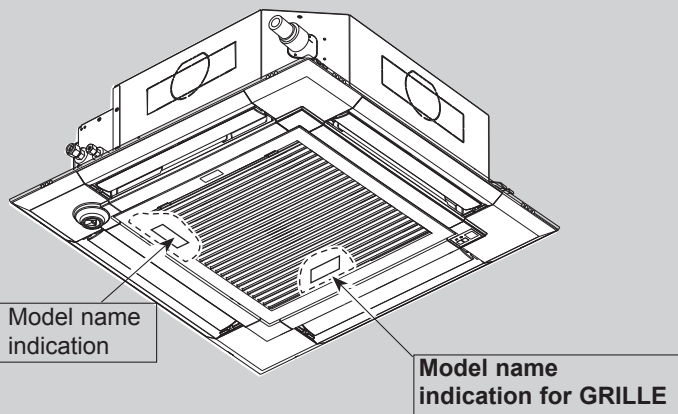

**WIRELESS REMOTE
CONTROLLER**
(Option)

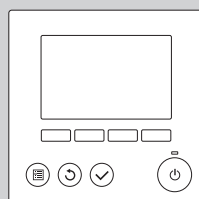

**WIRED REMOTE
CONTROLLER**
(Option)

CONTENTS

1. RoHS PARTS LIST2

SERVICE MANUAL (OCH626)

Mr. SLIM

PANEL PARTS

PLP-6EA (Standard)

PLP-6EAL (with signal receiver)

PLP-6EAE (with i-see Sensor)

PLP-6EALE (with signal receiver and i-see Sensor)

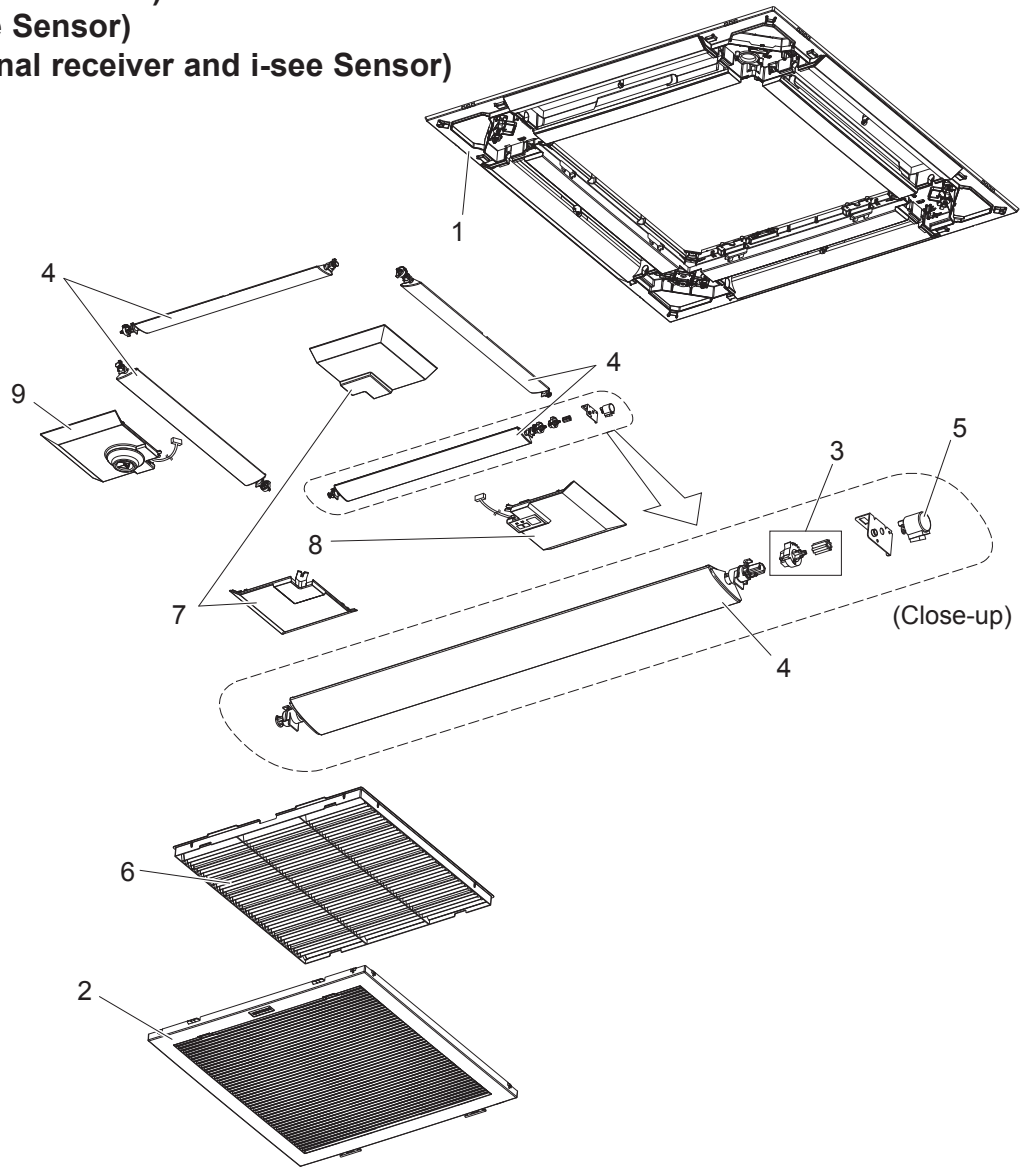

No.	RoHS	Part No.	Part Name	Specification	Q'ty/unit				Remarks (Drawing No.)	Wiring Diagram Symbol
					PLP-6					
					EA	EAL	EAE	EALE		
1	G	E17 D72 003	AIR OUTLET GRILLE		1	1	1	1		
2	G	E17 D72 010	INTAKE GRILLE		1	1	1	1		
3	G	E17 D72 031	GEAR (VANE&S/M)		4	4	4	4		
4	G	E17 D72 037	AUTO VANE&VANE BUSH	1PC/SET	4	4	4	4		
5	G	E17 103 303	VANE MOTOR	1PC/SET	4	4	4	4		MV
6	G	E17 D72 100	AIR FILTER		1	1	1	1		
7	G	E17 D72 975	CORNER PANEL		4	3	3	2		
8	G	E17 D73 975	CORNER PANEL (Signal receiver)			1		1		
9	G	E17 D74 975	CORNER PANEL (i-see Sensor)				1	1		

RoHS PARTS LIST

STRUCTURAL AND FUNCTIONAL PARTS

PLA-RP35EA.UK
 PLA-RP50EA.UK
 PLA-RP60EA.UK
 PLA-RP71EA.UK
 PLA-RP100EA.UK
 PLA-RP125EA.UK
 PLA-RP140EA.UK

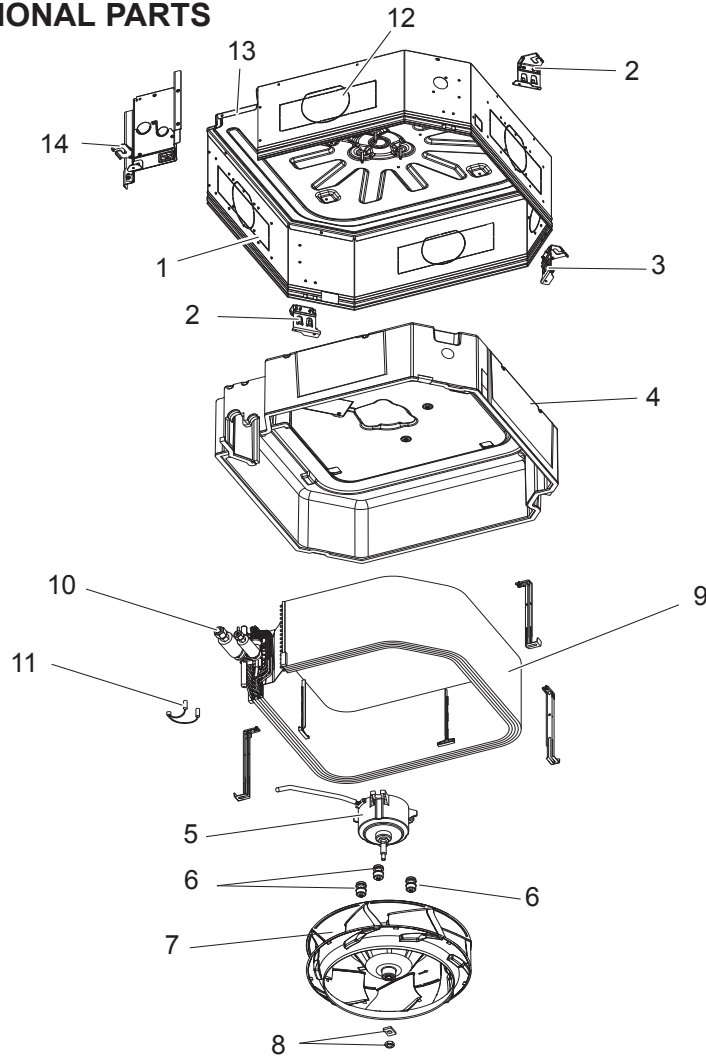

7LE00-A00JS

No.	RoHS	Part No.	Part Name	Specification	Q'ty/unit							Wiring Diagram Symbol
					PLA-RP-EA.UK							
					35	50	60	71	100	125	140	
1	G	S70 0B7 688	DRUM 2 ASSY		1	1	1	1				
	G	S70 0B8 688	DRUM 2 ASSY						1	1	1	
2	G	S70 EA2 130	LEG PUMP		2	2	2	2	2	2	2	
3	G	S70 EA1 130	LEG FA		1	1	1	1	1	1	1	
4	G	S70 0B4 659	INNER COVER ASSY-S		1	1	1	1				
	G	S70 0B5 659	INNER COVER ASSY-L						1	1	1	
5	G	S70 0B4 762	FAN MOTOR	(DC)-S	1	1	1	1				MF
	G	S70 0B5 762	FAN MOTOR	(DC)-M					1	1	1	MF
6	G	S70 0B1 105	MOTOR MOUNT		3	3	3	3	3	3	3	
7	G	S70 0B4 114	TURBO FAN		1	1	1	1	1	1	1	
8	G	S70 08K 097	SPL WASHER / NUT		1	1	1	1	1	1	1	
9	G	S70 B15 480	HEAT EXCHANGER		1	1						
	G	S70 B16 480	HEAT EXCHANGER				1					
	G	S70 B17 480	HEAT EXCHANGER					1				
	G	S70 B13 480	HEAT EXCHANGER						1			
	G	S70 B14 480	HEAT EXCHANGER							1	1	
10	G	S70 0B1 097	FLARE NUT	1/2"	1	1						
	G	S70 E10 097	FLARE NUT	1/4"	1	1						
	G	S70 E15 097	FLARE NUT	5/8"			1	1	1	1	1	
	G	S70 E17 097	FLARE NUT	3/8"			1	1	1	1	1	
11	G	S70 0B4 202	THERMISTOR		1	1	1	1	1	1	1	TH2/TH5
12	G	S70 0B5 688	DRUM 1 ASSY		1	1	1	1				
	G	S70 0B6 688	DRUM 1 ASSY						1	1	1	
13	G	S70 0B2 687	BASE		1	1	1	1	1	1	1	
14	G	S70 EA3 130	LEG PIPE		1	1	1	1	1	1	1	

RoHS PARTS LIST

FUNCTIONAL AND ELECTRICAL PARTS

PLA-RP35EA.UK
 PLA-RP50EA.UK
 PLA-RP60EA.UK
 PLA-RP71EA.UK
 PLA-RP100EA.UK
 PLA-RP125EA.UK
 PLA-RP140EA.UK

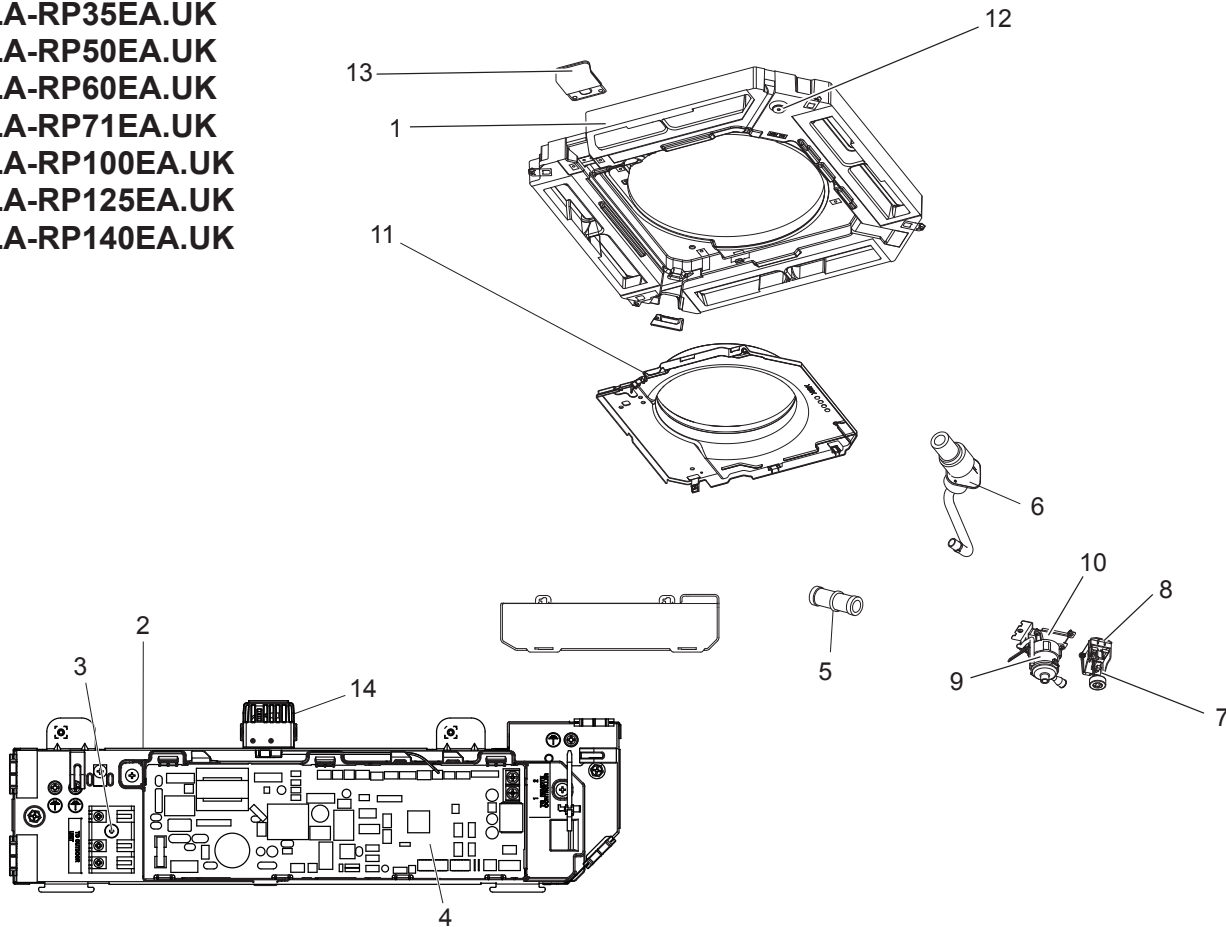

No.	RoHS	Part No.	Part Name	Specification	Q'ty/unit						Remarks (Drawing No.)	Wiring Diagram Symbol	
					PLA-RP-EA.UK								
					35	50	60	71	100	125			140
1	G	S70 0B4 529	DRAIN PAN		1	1	1	1	1	1	1		
2	G	S70 0B7 501	ELECTRICAL CONTROL BOX		1	1	1	1	1	1	1		
3	G	S70 K03 716	TERMINAL BLOCK	3P(S1,S2,S3)	1	1	1	1	1	1	1		TB4
4	G	S70 B14 310	INDOOR CONTROLLER BOARD		1	1	1	1	1	1	1		I.B
5	G	S70 29H 523	DRAIN SOCKET		1	1	1	1	1	1	1	Accessory	
6	G	S70 0B2 527	DRAIN HOSE ASSY		1	1	1	1	1	1	1		
7	G	S70 0B2 266	FLOAT SWITCH		1	1	1	1	1	1	1		FS
8	G	S70 0B2 533	FLOAT SWITCH BASE		1	1	1	1	1	1	1		
9	G	S70 0B2 355	DRAIN PUMP	220-240 V	1	1	1	1	1	1	1		DP
10	G	S70 0B3 533	DRAIN PUMP BASE		1	1	1	1	1	1	1		
11	G	S70 0B3 502	BELLMOUTH-S		1	1	1	1					
	G	S70 0B4 502	BELLMOUTH-L						1	1	1		
12	G	S70 A41 524	DRAIN PLUG		1	1	1	1	1	1	1		
13	G	S70 EA1 663	WIRE COVER		1	1	1	1	1	1	1		
14	G	S70 0B3 202	ROOM TEMP. THERMISTOR	220XAP	1	1	1	1	1	1	1		TH1

MITSUBISHI ELECTRIC CORPORATION

HEAD OFFICE : TOKYO BUILDING, 2-7-3, MARUNOUCHI, CHIYODA-KU, TOKYO 100-8310, JAPAN