

SERVICE MANUAL

Series PLA Ceiling Cassettes

R410A

 Indoor unit
 [Model Name] [Service Ref.]

PLA-RP35EA	PLA-RP35EA.UK
PLA-RP50EA	PLA-RP50EA.UK
PLA-RP60EA	PLA-RP60EA.UK
PLA-RP71EA	PLA-RP71EA.UK
PLA-RP100EA	PLA-RP100EA.UK
PLA-RP125EA	PLA-RP125EA.UK
PLA-RP140EA	PLA-RP140EA.UK

Notes:

- This manual describes service data of the indoor units only.
- RoHS compliant products have <G> mark on the spec name plate.

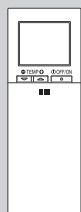
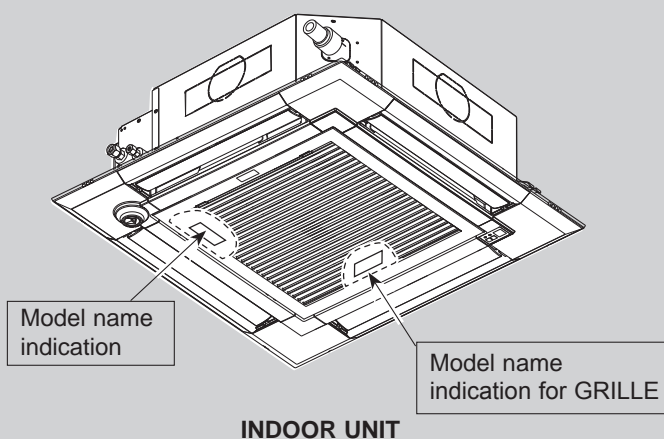
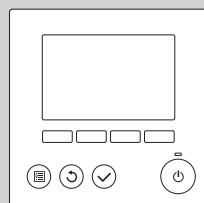
**WIRELESS REMOTE
CONTROLLER**
 (Option)

**WIRED REMOTE
CONTROLLER**
 (Option)

CONTENTS

1. REFERENCE MANUAL.....	2
2. SAFETY PRECAUTION.....	3
3. PARTS NAMES AND FUNCTIONS.....	4
4. SPECIFICATIONS.....	9
5. NOISE CRITERION CURVES.....	12
6. OUTLINES AND DIMENSIONS.....	14
7. WIRING DIAGRAM.....	15
8. REFRIGERANT SYSTEM DIAGRAM.....	16
9. TROUBLESHOOTING.....	17
10. SPECIAL FUNCTION.....	32
11. DISASSEMBLY PROCEDURE.....	38

PARTS CATALOG (OCB626)

OUTDOOR UNIT'S SERVICE MANUAL

Model Name	Service Ref.	Service Manual No.
PUHZ-ZRP35/50VKA2 PUHZ-ZRP60/71VHA2	PUHZ-ZRP35/50VKA2(-ER/ET) PUHZ-ZRP60/71VHA2(-ER/ET)	OCH635/OCB635
PUHZ-ZRP100/125/140VKA3 PUHZ-ZRP100/125/140YKA3 PUHZ-ZRP200/250YKA2	PUHZ-ZRP100/125/140VKA3.UK PUHZ-ZRP100/125/140YKA3.UK PUHZ-ZRP200/250YKA2.UK	OCH645/OCB645
SUZ-KA35VA6 SUZ-KA50VA6 SUZ-KA60VA6 SUZ-KA71VA6	SUZ-KA35VA6.TH(-ER/ET) SUZ-KA50VA6.TH(-ER/ET) SUZ-KA60VA6.TH(-ER/ET) SUZ-KA71VA6.TH(-ER/ET)	TCH004 TCB004
PUHZ-P100VHA5 PUHZ-P100YHA3 PUHZ-P125VHA4 PUHZ-P125YHA2 PUHZ-P140VHA4 PUHZ-P140YHA2	PUHZ-P100VHA5.UK PUHZ-P100YHA3.UK PUHZ-P125VHA4.UK PUHZ-P125YHA2.UK PUHZ-P140VHA4.UK PUHZ-P140YHA2.UK	OCH646/OCB646
PUHZ-P200YKA2 PUHZ-P250YKA2	PUHZ-P200YKA2.UK PUHZ-P250YKA2.UK	OCH647/OCB647
PUHZ-SHW112VHA PUHZ-SHW112/140YHA	PUHZ-SHW112VHAR4.UK PUHZ-SHW112/140YHAR4.UK	OCH526/OCB526
PUHZ-SHW230YKA2	PUHZ-SHW230YKA2	OCH594/OCB594
PUMY-P112/125/140VKM3 PUMY-P112/125/140YKM3 PUMY-P112/125/140YKME3	PUMY-P112/125/140VKM3(-BS) PUMY-P112/125/140YKM3(-BS) PUMY-P112/125/140YKME3(-BS)	OCH632/OCB632
PUMY-P200YKM1	PUMY-P200YKM1(-BS)	OCH634/OCB634
MXZ-3E54/68VA MXZ-4E72VA MXZ-4E83VA MXZ-5E102VA MXZ-4E83VAHZ	MXZ-3E54/68VA(-E1/-ET1/-ER1) MXZ-4E72VA(-E1/-ET1/-ER1) MXZ-4E83VA(-E2/-ET2/-ER1) MXZ-5E102VA(-E2/-ET2/-ER1) MXZ-4E83VAHZ(-E1/-ER1)	OBH723/OBB723
MXZ-6D122VA	MXZ-6D122VA(-E1/-ET1/-ER1)	OBH626/OBB626

2

SAFETY PRECAUTION

2-1. ALWAYS OBSERVE FOR SAFETY

Before obtaining access to terminal, all supply circuits must be disconnected.

2-2. CAUTIONS RELATED TO NEW REFRIGERANT

Caution for units utilising refrigerant R410A

Use new refrigerant pipes.

In case of using the existing pipes for R22, be careful with the following.

- Be sure to clean the pipes and make sure that the insides of the pipes are clean.
- Change flare nut to the one provided with this product. Use a newly flared pipe.
- Avoid using thin pipes.

Make sure that the inside and outside of refrigerant piping is clean and it has no contaminants such as sulfur, oxides, dirt, shaving particles, etc, which are hazard to refrigerant cycle. In addition, use pipes with specified thickness.

Contamination inside refrigerant piping can cause deterioration of refrigerant oil, etc.

Store the piping indoors, and keep both ends of the piping sealed until just before brazing. (Leave elbow joints, etc. in their packaging.)

If dirt, dust or moisture enters into refrigerant cycle, that can cause deterioration of refrigerant oil or malfunction of compressor.

The refrigerant oil applied to flare and flange connections must be ester oil, ether oil or alkylbenzene oil in a small amount.

If large amount of mineral oil enters, that can cause deterioration of refrigerant oil, etc.

Charge refrigerant from liquid phase of gas cylinder.

If the refrigerant is charged from gas phase, composition change may occur in refrigerant and the efficiency will be lowered.

Do not use refrigerant other than R410A.

If other refrigerant (R22, etc.) is used, chlorine in refrigerant can cause deterioration of refrigerant oil, etc.

Use a vacuum pump with a reverse flow check valve.

Vacuum pump oil may flow back into refrigerant cycle and that can cause deterioration of refrigerant oil, etc.

Use the following tools specifically designed for use with R410A refrigerant.

The following tools are necessary to use R410A refrigerant.

Tools for R410A	
Gauge manifold	Flare tool
Charge hose	Size adjustment gauge
Gas leak detector	Vacuum pump adaptor
Torque wrench	Electronic refrigerant charging scale

Handle tools with care.

If dirt, dust or moisture enters into refrigerant cycle, that can cause deterioration of refrigerant oil or malfunction of compressor.

Do not use a charging cylinder.

If a charging cylinder is used, the composition of refrigerant will change and the efficiency will be lowered.

Use the specified refrigerant only.

Never use any refrigerant other than that specified.

Doing so may cause a burst, an explosion, or fire when the unit is being used, serviced, or disposed of.

Correct refrigerant is specified in the manuals and on the spec labels provided with our products.

We will not be held responsible for mechanical failure, system malfunction, unit breakdown or accidents caused by failure to follow the instructions.

Ventilate the room if refrigerant leaks during operation. If refrigerant comes into contact with a flame, poisonous gases will be released.

[1] Cautions for service

- (1) Perform service after recovering the refrigerant left in unit completely.
- (2) Do not release refrigerant in the air.
- (3) After completing service, charge the cycle with specified amount of refrigerant.
- (4) When performing service, install a filter drier simultaneously.
Be sure to use a filter drier for new refrigerant.

[2] Additional refrigerant charge

When charging directly from cylinder

- (1) Check that cylinder for R410A available on the market is a syphon type.
- (2) Charging should be performed with the cylinder of syphon stood vertically. (Refrigerant is charged from liquid phase.)

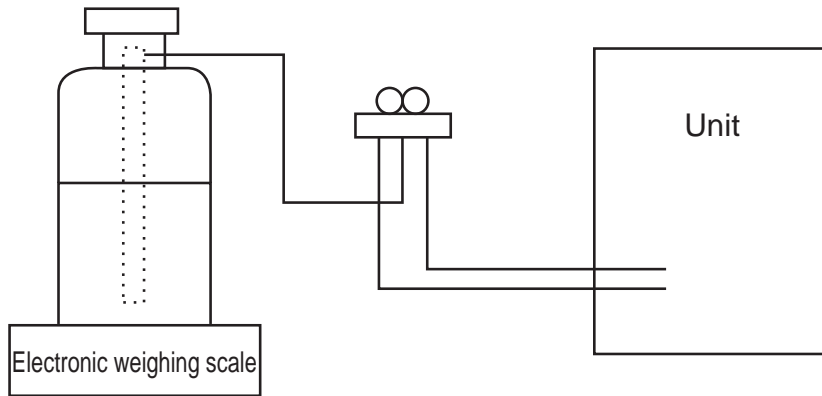

[3] Service tools

Use the below service tools as exclusive tools for R410A refrigerant.

No.	Tool name	Specifications
①	Gauge manifold	· Only for R410A
		· Use the existing fitting specifications. (UNF1/2)
		· Use high-tension side pressure of 5.3MPa-G or over.
②	Charge hose	· Only for R410A
		· Use pressure performance of 5.09MPa-G or over.
③	Electronic scale	—
④	Gas leak detector	· Use the detector for R134a, R407C or R410A.
⑤	Adaptor for reverse flow check	· Attach on vacuum pump.
⑥	Refrigerant charge base	—
⑦	Refrigerant cylinder	· Only for R410A · Top of cylinder (Pink)
		· Cylinder with syphon
⑧	Refrigerant recovery equipment	—

3 PARTS NAMES AND FUNCTIONS

3-1. INDOOR UNIT

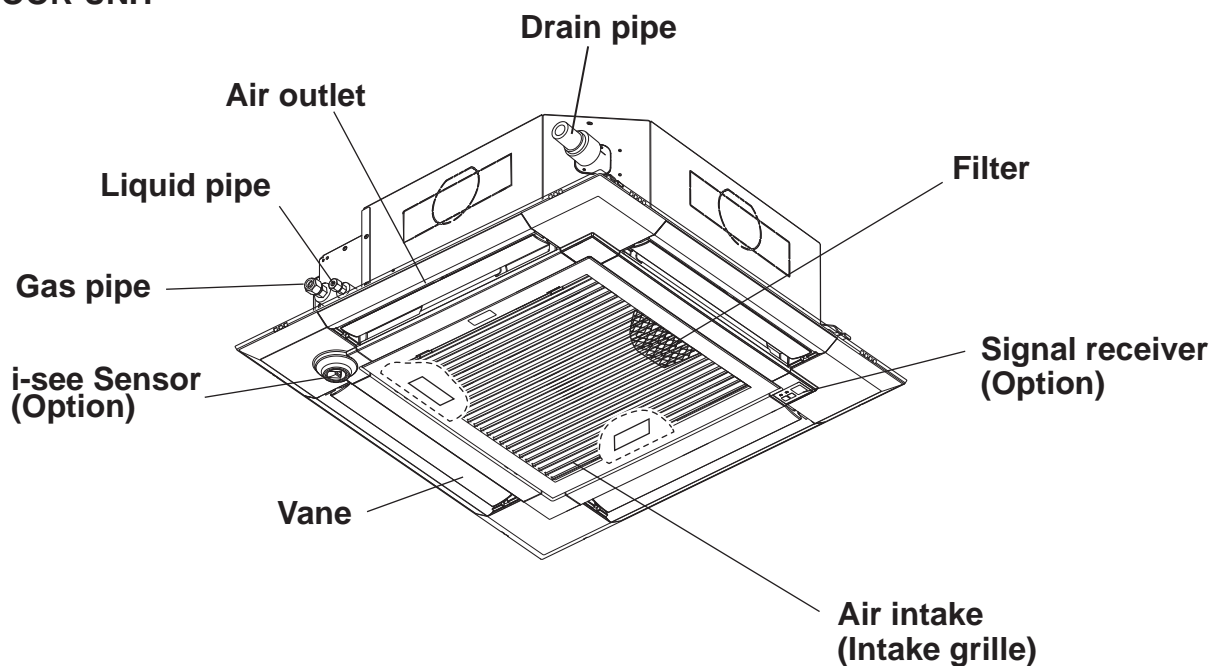

3-2. WIRELESS REMOTE CONTROLLER (Option)

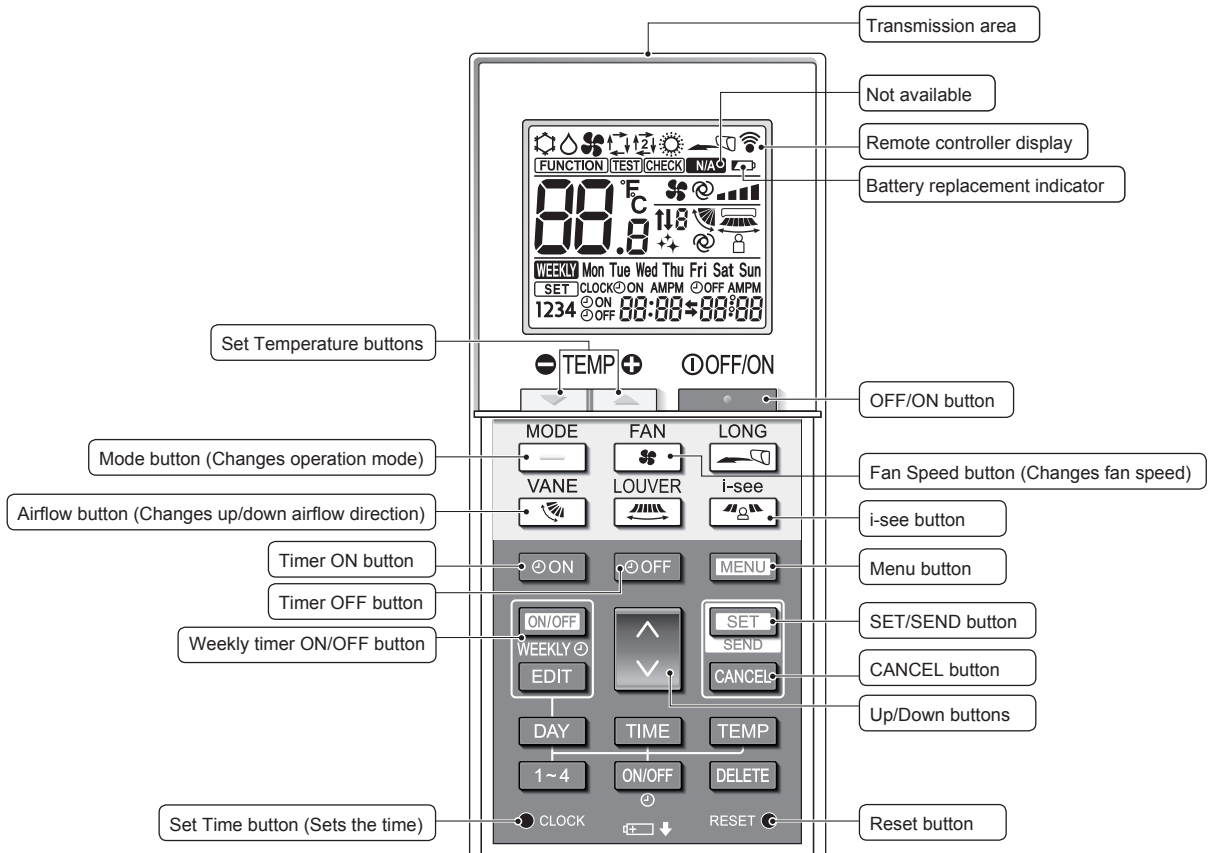

Operation mode

- Cool Dry
- Fan Auto
- Heat

Temperature setting
The units of temperature can be changed. For details, refer to the Installation Manual.

Vane setting
Step 1 Step 2 Step 3 Step 4 Step 5 Swing Auto

Not available
Appears when a non-supported function is selected.

Battery replacement indicator
Appears when the remaining battery power is low.

Fan speed setting

3D i-see Sensor (Air distribution)
Default Direct Indirect When Direct or Indirect is selected, the vane setting is set to "Auto".

3-3. Wired remote controller (Option) PAR-32MAA

The functions which can be used are restricted according to each model.

Display

The main display can be displayed in 2 different modes: "Full" and "Basic."
The initial setting is "Full."

Full mode

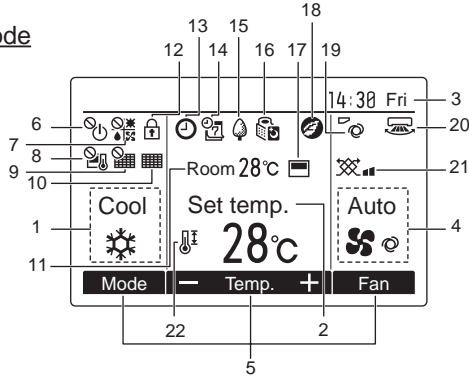

Basic mode

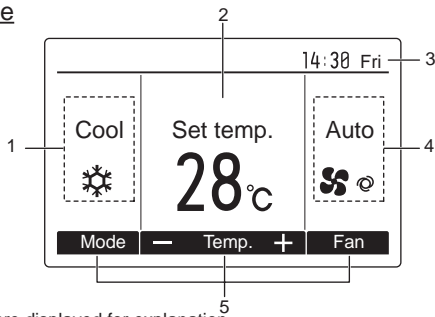

Note: All icons are displayed for explanation.

- 1 Operation mode**
Indoor unit operation mode appears here.
- 2 Preset temperature**
Preset temperature appears here.
- 3 Clock**
(See the Installation Manual.)
Current time appears here.
- 4 Fan speed**
Fan speed setting appears here.
- 5 Button function guide**
Functions of the corresponding buttons appear here.
- 6**
Appears when the ON/OFF operation is centrally controlled.
- 7**
Appears when the operation mode is centrally controlled.
- 8**
Appears when the preset temperature is centrally controlled.
- 9**
Appears when the filter reset function is centrally controlled.
- 10**
Indicates when filter needs maintenance.
- 11 Room temperature**
(See the Installation Manual.)
Current room temperature appears here.
- 12**
Appears when the buttons are locked.
- 13**
Appears when the On/Off timer or Night setback function is enabled.
- 14**
Appears when the Weekly timer is enabled.
- 15**
Appears while the units are operated in the energy-save mode.
- 16**
Appears while the outdoor units are operated in the silent mode.
- 17**
Appears when the built-in thermistor on the remote controller is activated to monitor the room temperature (a).
appears when the thermistor on the indoor unit is activated to monitor the room temperature.
- 18**
Appears when the units are operated in the energy-save mode with 3D i-See sensor.
- 19**
Indicates the vane setting.
- 20**
Indicates the louver setting.
- 21**
Indicates the ventilation setting.
- 22**
Appears when the preset temperature range is restricted.

Controller interface

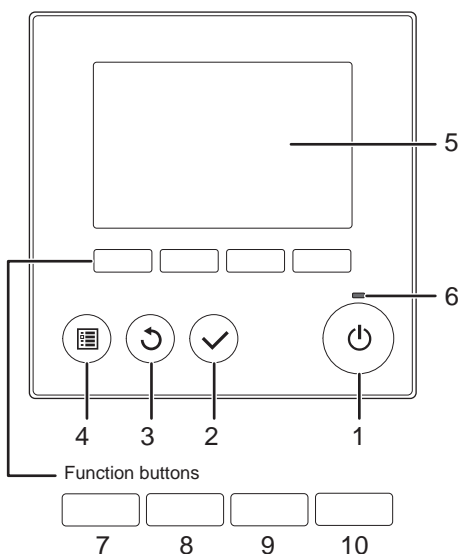

- When the backlight is off, pressing any button turns the backlight on and does not perform its function. (except for the ON/OFF button)
- Most settings (except ON/OFF, mode, fan speed, temperature) can be made from the Menu screen.

- 1 ON/OFF button**
Press to turn ON/OFF the indoor unit.
- 2 SELECT button**
Press to save the setting.
- 3 RETURN button**
Press to return to the previous screen.
- 4 MENU button**
Press to bring up the Main menu.
- 5 Backlit LCD**
Operation settings will appear.
When the backlight is off, pressing any button turns the backlight on and it will stay lit for a certain period of time depending on the screen.
- 6 ON/OFF lamp**
This lamp lights up in green while the unit is in operation. It blinks while the remote controller is starting up or when there is an error.

The functions of the function buttons change depending on the screen. Refer to the button function guide that appears at the bottom of the LCD for the functions they serve on a given screen. When the system is centrally controlled, the button function guide that corresponds to the locked button will not appear.

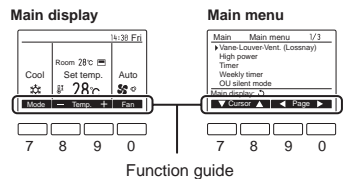

- 7 Function button [F1]**
Main display: Press to change the operation mode.
Main menu: Press to move the cursor down.
- 8 Function button [F2]**
Main display: Press to decrease temperature.
Main menu: Press to move the cursor up.
- 9 Function button [F3]**
Main display: Press to increase temperature.
Main menu: Press to go to the previous page.
- 10 Function button [F4]**
Main display: Press to change the fan speed.
Main menu: Press to go to the next page.

Menu structure

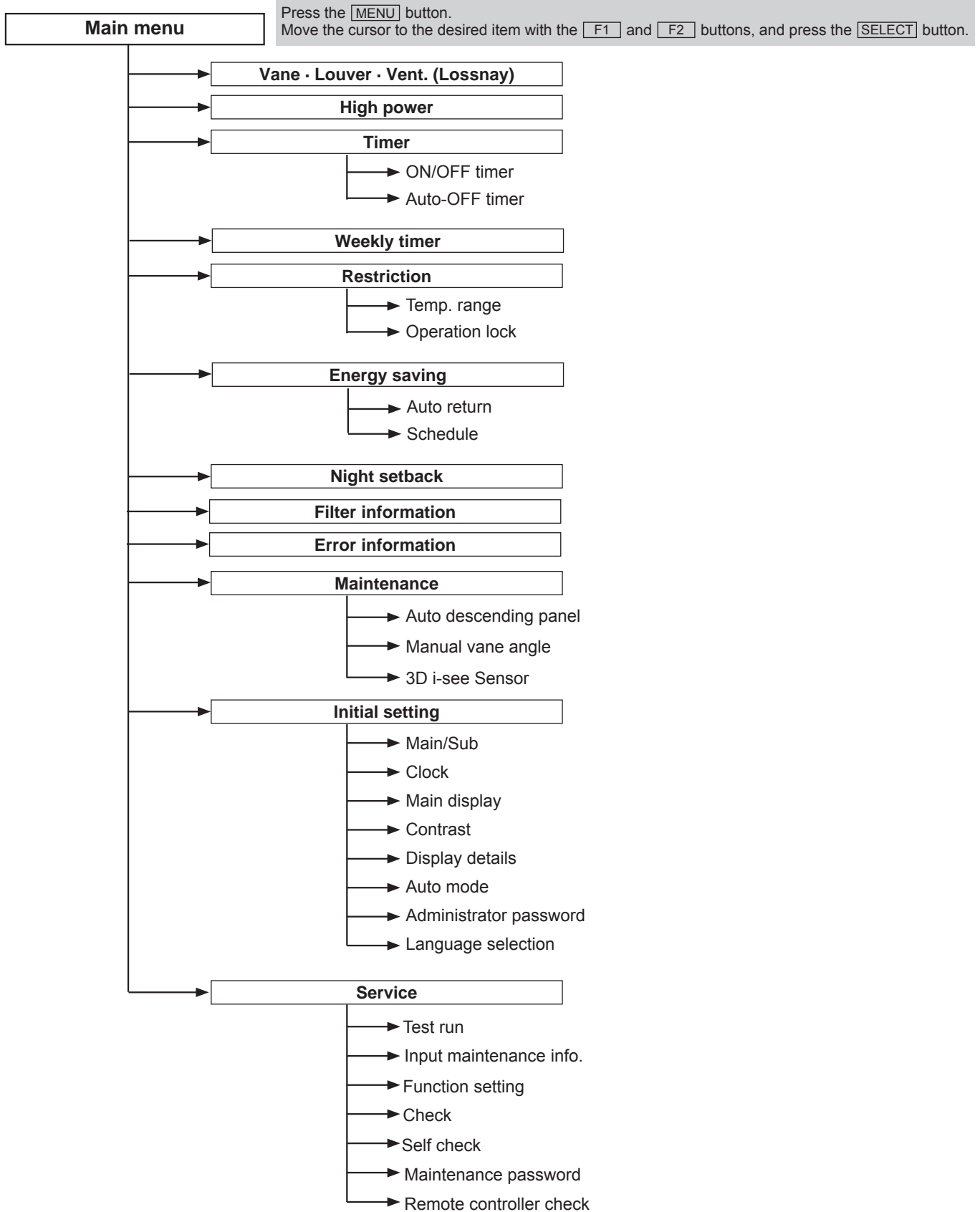

Not all functions are available on all models of indoor units.

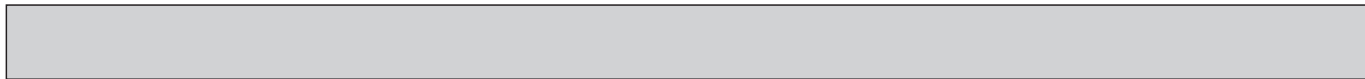

Setting and display items		Setting details
Vane · Louver · Vent. (Lossnay)		<p>Use to set the vane angle.</p> <ul style="list-style-type: none"> • Select a desired vane setting from 5 different settings. <p>Use to turn ON/OFF the louver.</p> <ul style="list-style-type: none"> • Select a desired setting from "ON" and "OFF." <p>Use to set the amount of ventilation.</p> <ul style="list-style-type: none"> • Select a desired setting from "OFF," "Low," and "High."
High power**		<p>Use to reach the comfortable room temperature quickly.</p> <ul style="list-style-type: none"> • Units can be operated in the High-power mode for up to 30 minutes.
Timer	ON/OFF timer*	<p>Use to set the operation ON/OFF times.</p> <ul style="list-style-type: none"> • Time can be set in 5-minute increments.
	Auto-Off timer	<p>Use to set the Auto-OFF time.</p> <ul style="list-style-type: none"> • Time can be set to a value from 30 to 240 in 10-minute increments.
Filter information		<p>Use to check the filter status.</p> <ul style="list-style-type: none"> • The filter sign can be reset.
Error information		<p>Use to check error information when an error occurs.</p> <ul style="list-style-type: none"> • Check code, error source, refrigerant address, unit model, manufacturing number, contact information (dealer's phone number) can be displayed. (The unit model, manufacturing number, and contact information need to be registered in advance to be displayed.)
Weekly timer*		<p>Use to set the weekly operation ON/OFF times.</p> <ul style="list-style-type: none"> • Up to 8 operation patterns can be set for each day. (Not valid when the ON/OFF timer is enabled.)
Energy saving	Auto return	<p>Use to get the units to operate at the preset temperature after performing energy-save operation for a specified time period.</p> <ul style="list-style-type: none"> • Time can be set to a value from 30 and 120 in 10-minute increments. (This function will not be valid when the preset temperature ranges are restricted.)
	Schedule*	<p>Set the start/stop times to operate the units in the energy-save mode for each day of the week, and set the energy-saving rate.</p> <ul style="list-style-type: none"> • Up to 4 energy-save operation patterns can be set for each day. • Time can be set in 5-minute increments. • Energy-saving rate can be set to a value from 0% and 50 to 90% in 10% increments.
Night setback*		<p>Use to make Night setback settings.</p> <ul style="list-style-type: none"> • Select "Yes" to enable the setting, and "No" to disable the setting. The temperature range and the start/stop times can be set.
Restriction	Temp. range	<p>Use to restrict the preset temperature range.</p> <ul style="list-style-type: none"> • Different temperature ranges can be set for different operation modes.
	Operation lock	<p>Use to lock selected functions.</p> <ul style="list-style-type: none"> • The locked functions cannot be operated.
Maintenance	Auto descending panel	Auto descending panel (Optional parts) UP/DOWN you can do.
	Manual vane angle	Use to set the vane angle for each vane to a fixed position.
	3D i-See sensor	<p>Use to set the following functions for 3D i-see Sensor.</p> <ul style="list-style-type: none"> • Air distribution • Energy saving option • Seasonal airflow
Initial setting	Main/Sub	When connecting 2 remote controllers, one of them needs to be designated as a sub controller.
	Clock	Use to set the current time.
	Main display	<p>Use to switch between "Full" and "Basic" modes for the Main display.</p> <ul style="list-style-type: none"> • The initial setting is "Full."
	Contrast	Use to adjust screen contrast.
Initial setting	Display details	<p>Make the settings for the remote controller related items as necessary.</p> <p>Clock: The initial settings are "Yes" and "24h" format.</p> <p>Temperature: Set either Celsius (°C) or Fahrenheit (°F).</p> <p>Room temp.: Set Show or Hide.</p> <p>Auto mode: Set the Auto mode display or Only Auto display.</p>
	Auto mode	<p>Whether or not to use the AUTO mode can be selected by using the button.</p> <p>This setting is valid only when indoor units with the AUTO mode function are connected.</p>
	Administrator password	<p>The administrator password is required to make the settings for the following items.</p> <ul style="list-style-type: none"> • Timer setting • Energy-save setting • Weekly timer setting • Restriction setting • Outdoor unit silent mode setting • Night set back
	Language selection	Use to select the desired language.
Service	Test run	<p>Select "Test run" from the Service menu to bring up the Test run menu.</p> <ul style="list-style-type: none"> • Test run • Drain pump test run
	Input maintenance	<p>Select "Input maintenance Info." from the Service menu to bring up the Maintenance information screen. The following settings can be made from the Maintenance Information screen.</p> <ul style="list-style-type: none"> • Model name input • Serial No. input • Dealer information input
	Function setting	Make the settings for the indoor unit functions via the remote controller as necessary.
	LOSSNAY setting (City Multi only)	This setting is required only when the operation of City Multi units is interlocked with LOSSNAY units.
	Check	<p>Error history: Display the error history and execute "delete error history".</p> <p>Refrigerant leak check (**): Refrigerant leaks can be judged.</p> <p>Smooth maintenance (**): The indoor and outdoor maintenance data can be displayed.</p> <p>Request code (**): Details of the operation data including each thermistor temperature and error history can be checked.</p>
	Self check	Error history of each unit can be checked via the remote controller.
	Maintenance password	Use to change the maintenance password.
Remote controller check	When the remote controller does not work properly, use the remote controller checking function to troubleshoot the problem.	

* Clock setting is required.

** The function is not available for SUZ models/some of P models.

4

SPECIFICATIONS

Service Ref.			PLA-RP35EA.UK		
INDOOR UNIT	Mode		Cooling	Heating	
	Power supply (phase, cycle, voltage)		Single phase, 50Hz, 230 V		
	Input	kW	0.03	0.03	
	Running current	A	0.20	0.18	
	External finish (Grille)		Munsell 1.0Y 9.2/0.2		
	Heat exchanger		Plate fin coil		
	Fan	Fan (drive) × No.		Turbo fan (direct) × 1	
		Fan motor output	kW	0.050	
		Airflow (Low-Medium2-Medium1-High)	m ³ /min	11-13-15-16	
		External static pressure	Pa (mmAq)	0(direct blow)	
	Booster heater		kW	-	
	Operation control & Thermostat		Remote controller & built-in		
	Noise level SPL(Low-Medium2-Medium1-High)		dB(A)		26-28-29-31
	Field drain pipe O.D.		mm (in)		32 (1-1/4)
	Dimensions	W	mm (in)	UNIT : 840 (33-1/16)	GRILLE : 950 (37-3/8)
		D	mm (in)	UNIT : 840 (33-1/16)	GRILLE : 950 (37-3/8)
		H	mm (in)	UNIT : 258 (10-3/16)	GRILLE : 40 (1-9/16)
Weight		kg	UNIT : 19	GRILLE : 5	

Service Ref.			PLA-RP50EA.UK		
INDOOR UNIT	Mode		Cooling	Heating	
	Power supply (phase, cycle, voltage)		Single phase, 50Hz, 230 V		
	Input	kW	0.03	0.03	
	Running current	A	0.22	0.20	
	External finish (Grille)		Munsell 1.0Y 9.2/0.2		
	Heat exchanger		Plate fin coil		
	Fan	Fan (drive) × No.		Turbo fan (direct) × 1	
		Fan motor output	kW	0.050	
		Airflow (Low-Medium2-Medium1-High)	m ³ /min	12-14-16-18	
		External static pressure	Pa (mmAq)	0(direct blow)	
	Booster heater		kW	-	
	Operation control & Thermostat		Remote controller & built-in		
	Noise level SPL (Low-Medium2-Medium1-High)		dB(A)		27-29-31-32
	Field drain pipe O.D.		mm (in)		32(1-1/4)
	Dimensions	W	mm (in)	UNIT : 840 (33-1/16)	GRILLE : 950 (37-3/8)
		D	mm (in)	UNIT : 840 (33-1/16)	GRILLE : 950 (37-3/8)
		H	mm (in)	UNIT : 258 (10-3/16)	GRILLE : 40 (1-9/16)
Weight		kg	UNIT : 19	GRILLE : 5	

Service Ref.			PLA-RP60EA.UK		
INDOOR UNIT	Mode		Cooling	Heating	
	Power supply (phase, cycle, voltage)		Single phase, 50Hz, 230 V		
	Input	kW	0.03	0.03	
	Running current	A	0.24	0.22	
	External finish (Grille)		Munsell 1.0Y 9.2/0.2		
	Heat exchanger		Plate fin coil		
	Fan	Fan (drive) × No.		Turbo fan (direct) × 1	
		Fan motor output	kW	0.050	
		Airflow (Low-Medium2-Medium1-High)	Pa (mmAq)	12-14-16-18	
		External static pressure	kW	0(direct blow)	
	Booster heater		kW	-	
	Operation control & Thermostat		Remote controller & built-in		
	Noise level SPL (Low-Medium2-Medium1-High)		dB(A)		27-29-31-32
	Field drain pipe O.D.		mm (in)		32(1-1/4)
	Dimensions	W	mm (in)	UNIT : 840 (33-1/16)	GRILLE : 950 (37-3/8)
		D	mm (in)	UNIT : 840 (33-1/16)	GRILLE : 950 (37-3/8)
		H	mm (in)	UNIT : 258 (10-3/16)	GRILLE : 40 (1-9/16)
Weight		kg	UNIT : 21	GRILLE : 5	

Service Ref.			PLA-RP71EA.UK	
Mode			Cooling	Heating
Power supply (phase, cycle, voltage)			Single phase, 50Hz, 230 V	
Input		kW	0.04	0.04
Running current		A	0.27	0.25
External finish (Grille)			Munsell 1.0Y 9.2/0.2	
Heat exchanger			Plate fin coil	
Fan	Fan (drive) × No.		Turbo fan (direct) × 1	
	Fan motor output		0.05	
	Airflow (Low-Medium2-Medium1-High)		14-17-19-21	
	External static pressure		0(direct blow)	
Booster heater		kW	-	
Operation control & Thermostat			Remote controller & built-in	
Noise level SPL (Low-Medium2-Medium1-High)		dB(A)	28-30-32-34	
Field drain pipe O.D.		mm (in)	32(1-1/4)	
Dimensions	W	mm (in)	UNIT : 840 (33-1/16)	GRILLE : 950 (37-3/8)
	D	mm (in)	UNIT : 840 (33-1/16)	GRILLE : 950 (37-3/8)
	H	mm (in)	UNIT : 258 (10-3/16)	GRILLE : 40 (1-9/16)
Weight		kg	UNIT : 21	GRILLE : 5

Service Ref.			PLA-RP100EA.UK	
Mode			Cooling	Heating
Power supply (phase, cycle, voltage)			Single phase, 50Hz, 230 V	
Input		kW	0.07	0.07
Running current		A	0.46	0.44
External finish (Grille)			Munsell 1.0Y 9.2/0.2	
Heat exchanger			Plate fin coil	
Fan	Fan (drive) × No.		Turbo fan (direct) × 1	
	Fan motor output		0.120	
	Airflow (Low-Medium2-Medium1-High)		19-23-26-29	
	External static pressure		0(direct blow)	
Booster heater		kW	-	
Operation control & Thermostat			Remote controller & built-in	
Noise level SPL (Low-Medium2-Medium1-High)		dB(A)	31-34-37-40	
Field drain pipe O.D.		mm (in)	32(1-1/4)	
Dimensions	W	mm (in)	UNIT : 840 (33-1/16)	GRILLE : 950 (37-3/8)
	D	mm (in)	UNIT : 840 (33-1/16)	GRILLE : 950 (37-3/8)
	H	mm (in)	UNIT : 298 (11-3/4)	GRILLE : 40 (1-9/16)
Weight		kg	UNIT : 24	GRILLE : 5

Service Ref.			PLA-RP125EA.UK	
Mode			Cooling	Heating
Power supply (phase, cycle, voltage)			Single phase, 50Hz, 230 V	
Input		kW	0.10	0.10
Running current		A	0.66	0.64
External finish (Grille)			Munsell 1.0Y 9.2/0.2	
Heat exchanger			Plate fin coil	
Fan	Fan (drive) × No.		Turbo fan (direct) × 1	
	Fan motor output		0.120	
	Airflow (Low-Medium2-Medium1-High)		21-25-28-31	
	External static pressure		0(direct blow)	
Booster heater		kW	-	
Operation control & Thermostat			Remote controller & built-in	
Noise level SPL (Low-Medium2-Medium1-High)		dB(A)	33-37-41-44	
Field drain pipe O.D.		mm (in)	32(1-1/4)	
Dimensions	W	mm (in)	UNIT : 840 (33-1/16)	GRILLE : 950 (37-3/8)
	D	mm (in)	UNIT : 840 (33-1/16)	GRILLE : 950 (37-3/8)
	H	mm (in)	UNIT : 298 (11-3/4)	GRILLE : 40 (1-9/16)
Weight		kg	UNIT : 26	GRILLE : 5

Service Ref.			PLA-RP140EA.UK		
INDOOR UNIT	Mode		Cooling	Heating	
	Power supply (phase, cycle, voltage)		Single phase, 50Hz, 230 V		
	Input	kW	0.10	0.10	
	Running current	A	0.66	0.64	
	External finish (Grille)		Munsell 1.0Y 9.2/0.2		
	Heat exchanger		Plate fin coil		
	Fan	Fan(drive) × No.		Turbo fan (direct) × 1	
		Fan motor output		0.120	
		Airflow (Low-Medium2-Medium1-High)		24-26-29-32	
		External static pressure		0(direct blow)	
	Booster heater		kW		
	Operation control & Thermostat		Remote controller & built-in		
	Noise level SPL (Low-Medium2-Medium1-High)		dB(A)		
	Field drain pipe O.D.		mm (in)		
	Dimensions	W	mm (in)	UNIT : 840 (33-1/16) GRILLE : 950 (37-3/8)	
D		mm (in)	UNIT : 840 (33-1/16) GRILLE : 950 (37-3/8)		
H		mm (in)	UNIT : 298 (11-3/4) GRILLE : 40 (1-9/16)		
Weight		kg	UNIT : 26	GRILLE : 5	

PLA-RP35EA.UK

NOTCH	SPL(dB)	LINE
High	31	○—○
Medium1	29	●—●
Medium2	28	△—△
Low	26	▲—▲

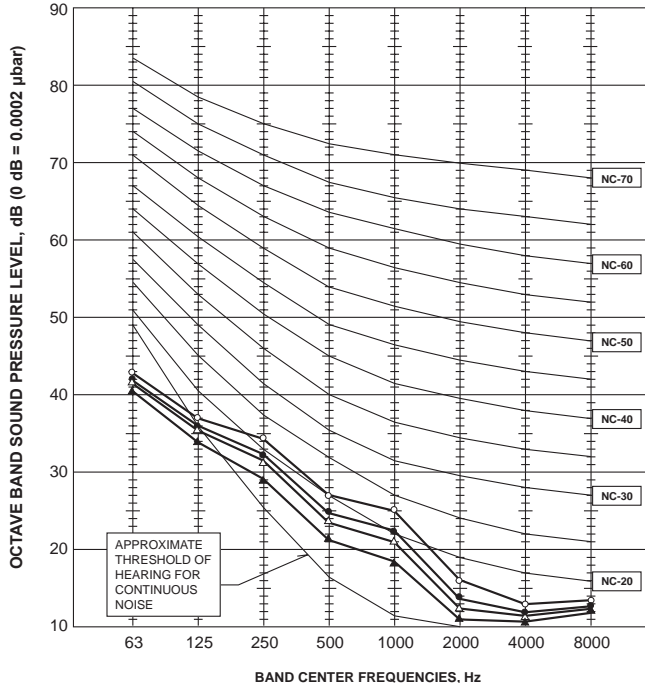

PLA-RP50EA.UK
PLA-RP60EA.UK

NOTCH	SPL(dB)	LINE
High	32	○—○
Medium1	31	●—●
Medium2	29	△—△
Low	27	▲—▲

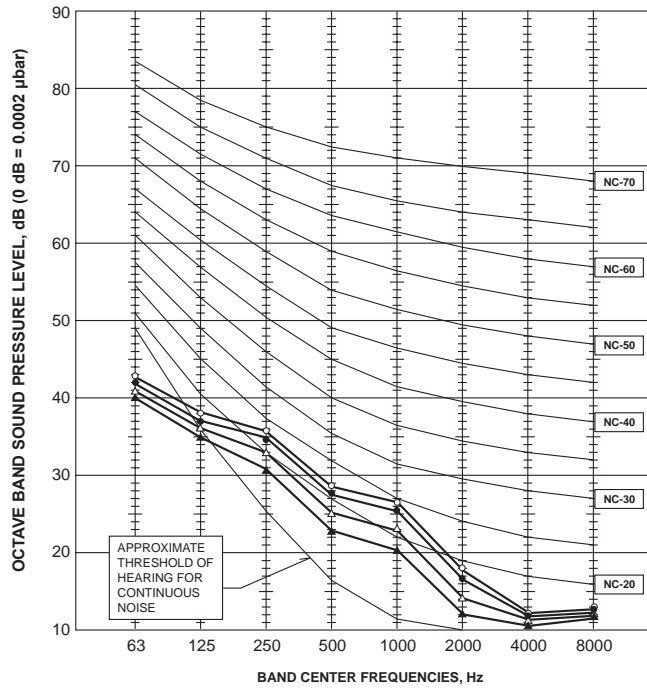

PLA-RP71EA.UK

NOTCH	SPL(dB)	LINE
High	34	○—○
Medium1	32	●—●
Medium2	30	△—△
Low	28	▲—▲

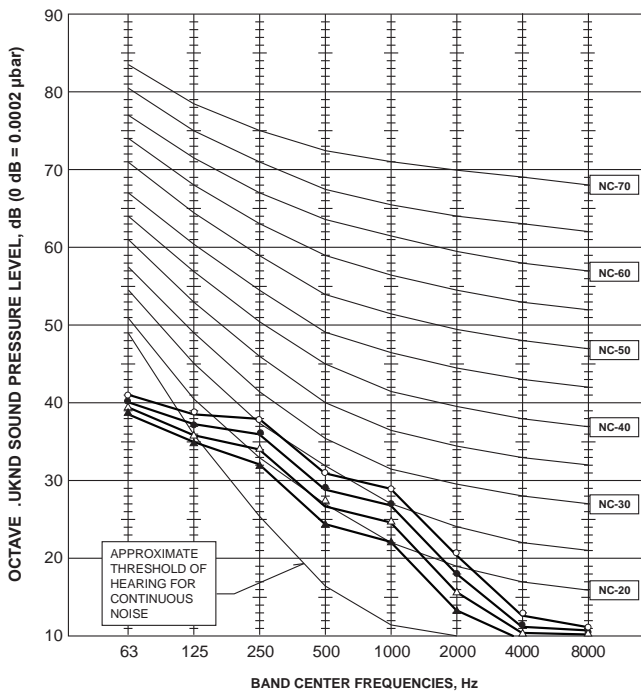

PLA-RP100EA.UK

NOTCH	SPL(dB)	LINE
High	40	○—○
Medium1	37	●—●
Medium2	34	△—△
Low	31	▲—▲

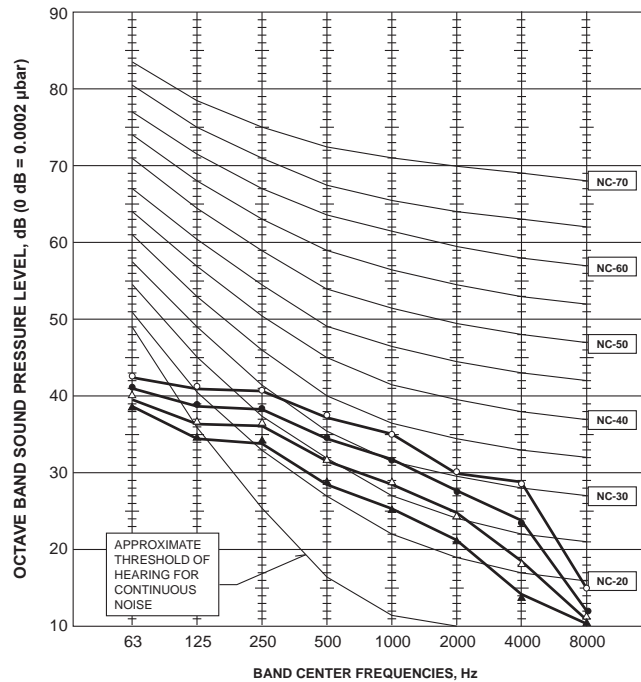

PLA-RP125EA.UK

NOTCH	SPL(dB)	LINE
High	44	○—○
Medium1	41	●—●
Medium2	37	△—△
Low	33	▲—▲

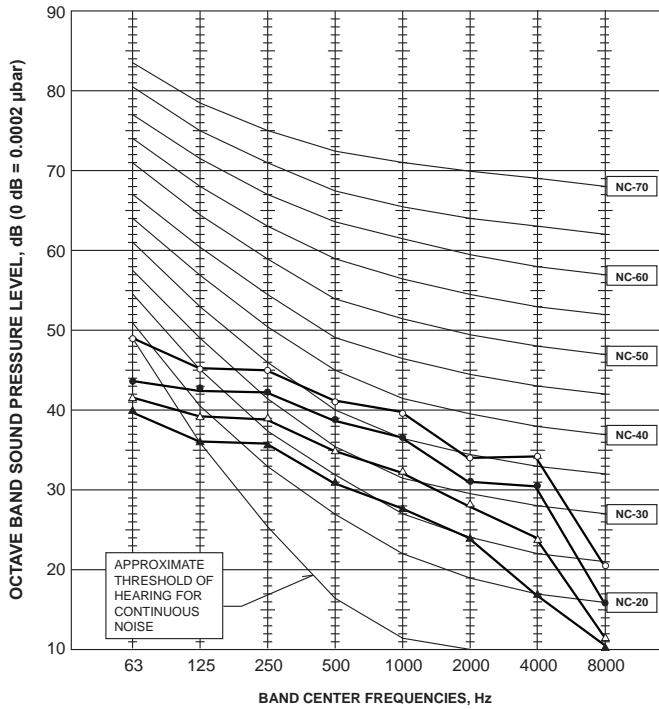

PLA-RP140EA.UK

NOTCH	SPL(dB)	LINE
High	44	○—○
Medium1	42	●—●
Medium2	39	△—△
Low	36	▲—▲

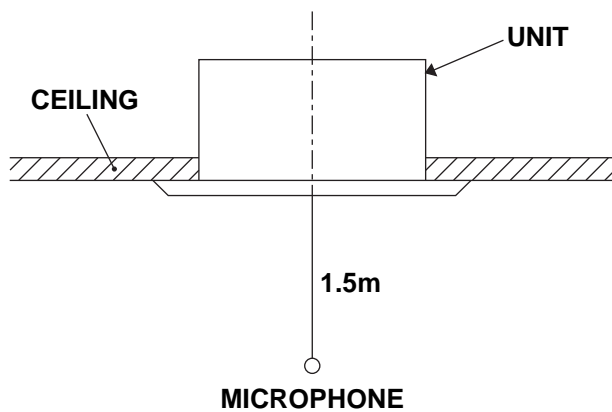
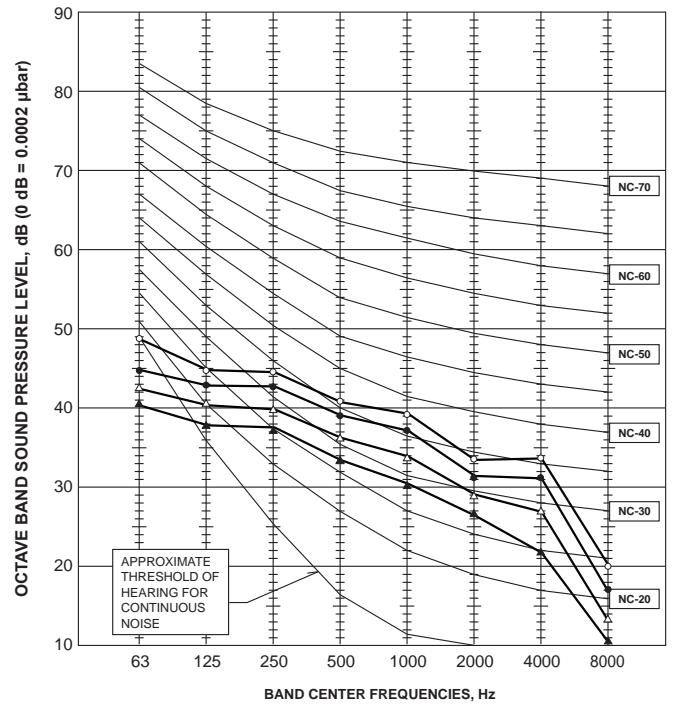

PLA-RP35EA.UK
PLA-RP71EA.UK

PLA-RP50EA.UK
PLA-RP100EA.UK

PLA-RP60EA.UK
PLA-RP125EA.UK

PLA-RP140EA.UK

Unit: mm

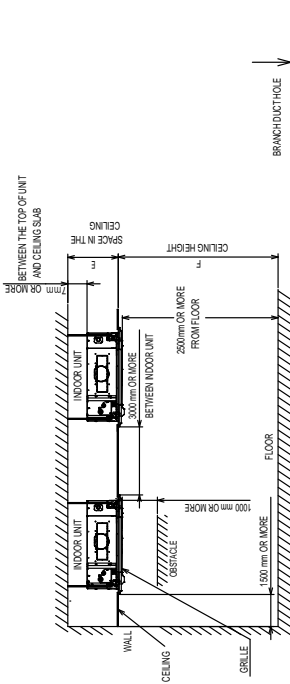
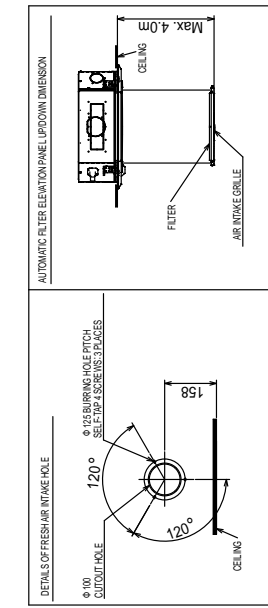

- NOTE1. CHOOSE THE GRILLE AMONG THE DEDICATED GRILLES.
2. REINFORCE THE SUSPENSION BOLT FOR EARTHQUAKE-RESISTANCE AS NEEDED.
3. FOR THE SUSPENSION BOLT USE M10 OR W3/8. (PROCURED AT THE LOCAL SITE.)
4. FOR DRAIN PIPE, USE VP-25 (O.D. ϕ 32 PVC TUBE).
5. DRAIN PUMP INCLUSION.
6. PAISE IS MAX 800mm FROM THE CEILING.
7. IN CASE OF USING SUSPENSION BOLT FOR THE SERVICE PURPOSE, PLEASE MAKE SURE TO SLACK THE ELECTRICAL WIRE LITTLE BIT FOR CONTROL POWER WIRES CONNECTION.
8. THE HEIGHT OF THE INDOOR UNIT IS ABLE TO BE ADJUSTED WITH THE GRILLE ATTACHED.
7. REQUIRES 'E' OR MORE SPACE BETWEEN TRANSOM AND CEILING FOR THE INSTALLATION.
8. WHEN INSTALLING THE BRANCH DUCTS, BE SURE TO INSULATE ADEQUATELY. OTHERWISE CONDENSATION AND DRIPPING MAY OCCUR. (IT BECOMES THE CAUSE OF DEW DROP-SWEAR DEW.)
9. AS FOR NECESSARY INSTALLATION/SERVICE SPACE, PLEASE REFER TO THE RIGHT AT FIGURE.
10. FOR THE INSTALLATION OF THE OPTIONAL HIGH EFFICIENCY FILTER OR MULTI-FUNCTIONAL CASEMENT, REFER TO SPECIAL DRAWING.

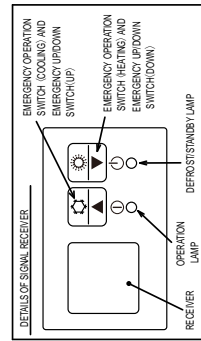
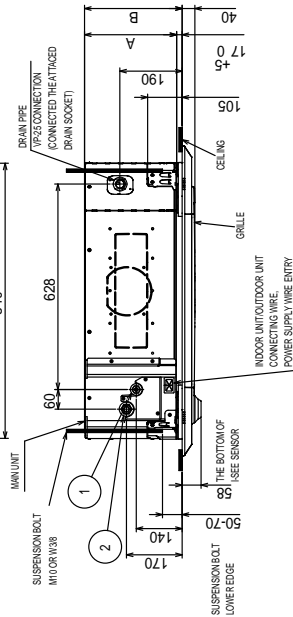
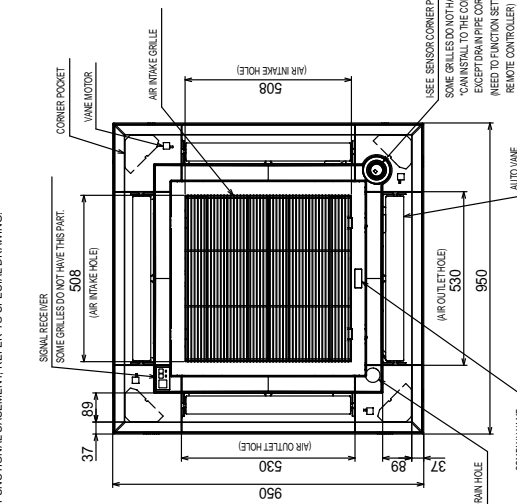
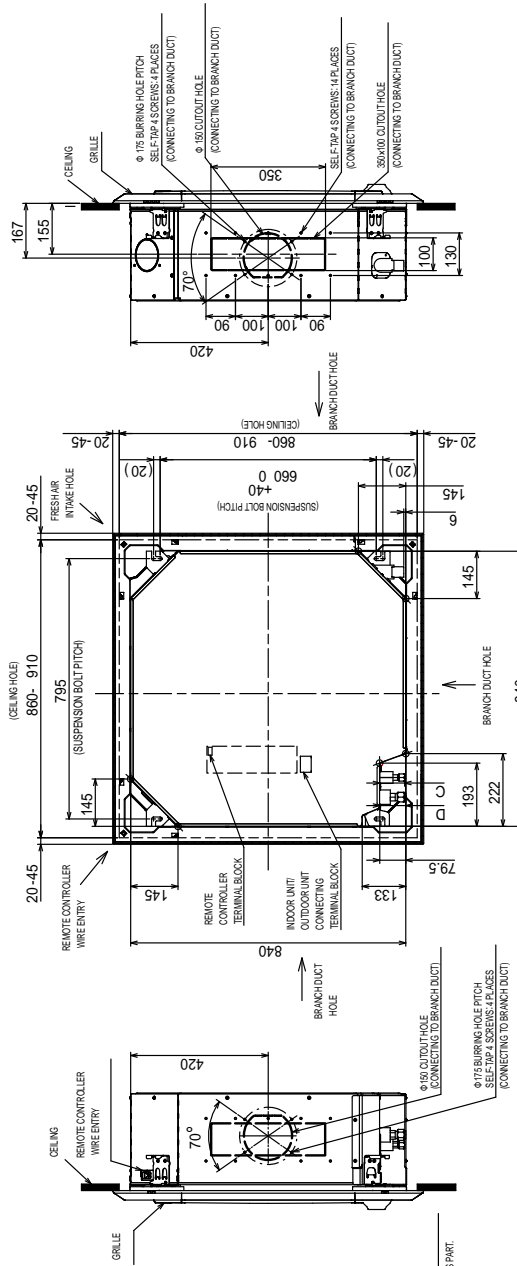

RP	(1)	(2)	A	B	C	D	E	F
35/50	REFRIGERANT PIPE $\phi 6.35$ FLARED CONNECTION 1/4"	REFRIGERANT PIPE $\phi 7.7$ FLARED CONNECTION 1/2"	76	76.5				
60	REFRIGERANT PIPE FLARED CONNECTION (COMPRESSOR)		241	259	80.5			
71	REFRIGERANT PIPE $\phi 15.88$ FLARED CONNECTION 3/8"				79.5			
100-140	REFRIGERANT PIPE $\phi 9.53$ FLARED CONNECTION 3/8"		281	288	79.5	30.5	4.00	30.5 OR MORE

PLA-RP35EA.UK
PLA-RP71EA.UK

PLA-RP50EA.UK
PLA-RP100EA.UK

PLA-RP60EA.UK
PLA-RP125EA.UK

PLA-RP140EA.UK

[LEGEND]

SYMBOL	NAME	SYMBOL	NAME
I.B	INDOOR CONTROLLER BOARD	TB4	TERMINAL BLOCK (INDOOR/OUTDOOR CONNECTING LINE)
CN2L	CONNECTOR (LOSSNAY)	TB5,TB6	TERMINAL BLOCK (REMOTE CONTROLLER TRANSMISSION LINE)
CN32	CONNECTOR (REMOTE SWITCH)	TH1	ROOM TEMP. THERMISTOR (0°C / 15kΩ, 25°C / 5.4kΩ DETECT)
CN41	CONNECTOR (HA TERMINAL-A)	TH2	PIPE TEMP. THERMISTOR/LIQUID (0°C / 15kΩ, 25°C / 5.4kΩ DETECT)
CN51	CONNECTOR (CENTRALLY CONTROL)	TH5	COND. / EVA. TEMP. THERMISTOR (0°C / 15kΩ, 25°C / 5.4kΩ DETECT)
F1	FUSE (T6.3AL250V)	R.B	WIRED REMOTE CONTROLLER
LED1	POWER SUPPLY (I.B)	OPTION PART	
LED2	POWER SUPPLY (R.B)	W.B	PCB OF SIGNAL RECEIVER
LED3	TRANSMISSION (INDOOR-OUTDOOR)	BZ	BUZZER
SW1	SWITCH (MODEL SELECTION) Refer to <Table 1>	LED1	LED (OPERATION INDICATION : GREEN)
SW2	SWITCH (CAPACITY CODE) Refer to <Table 2>	LED2	LED (PREPARATION FOR HEATING : ORANGE)
SWE	CONNECTOR (EMERGENCY OPERATION)	RU	RECEIVING UNIT
DP	DRAIN PUMP	SW1	EMERGENCY OPERATION (HEAT / DOWN)
FS	DRAIN FLOAT SWITCH	SW2	EMERGENCY OPERATION (COOL / UP)
MF	FAN MOTOR	MT	I-SEE SENSOR MOTOR
MV	VANE MOTOR	TB2	TERMINAL BLOCK (INDOOR UNIT POWER AND TRANSMISSION LINE)

<Table 1> SW1 (MODEL SELECTION)

MODELS	Manufacture/Service
PLA-RP-EA	

<Table 2> SW2 (CAPACITY CODE)

CAPACITY	Manufacture/Service	CAPACITY	Manufacture/Service	CAPACITY	Manufacture/Service
35		71		140	
50		100			
60		125			

The black square (■) indicates a switch position.

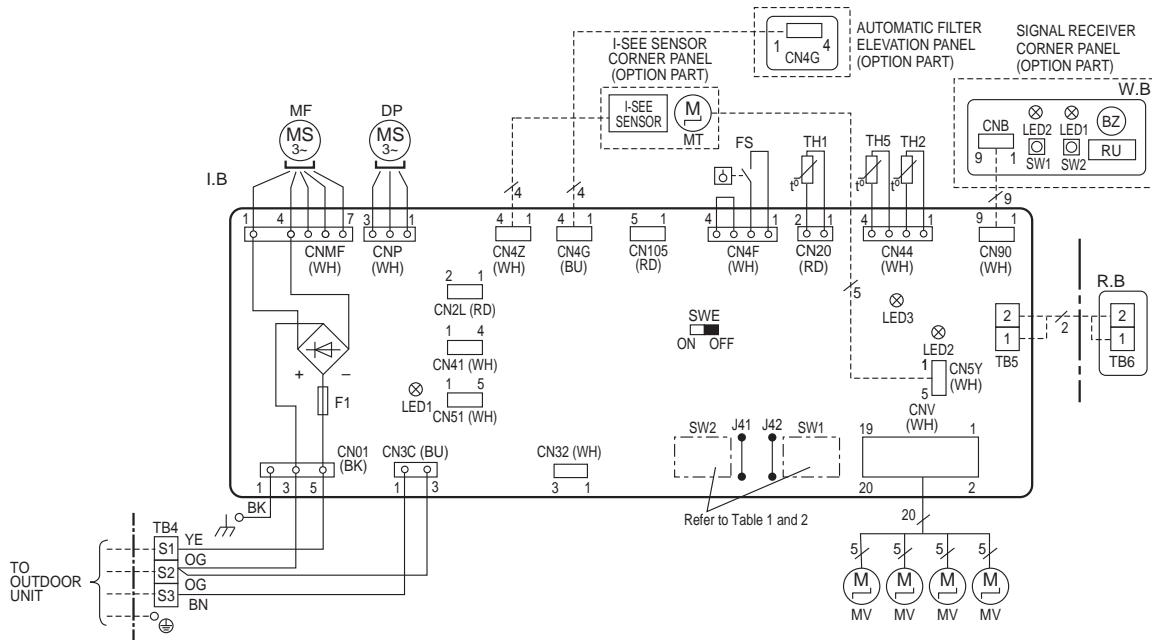

- Notes:
1. Symbols used in wiring diagram above are, : Terminal (block), : Connector.
 2. Indoor and outdoor connecting wires are made with polarities, make wiring matching terminal numbers (S1, S2, S3).
 3. Since the outdoor side electric wiring may change be sure to check the outdoor unit electric wiring for servicing.
 4. This diagram shows the wiring of indoor and outdoor connecting wires (specification of 230V), adopting superimposed system of power and signal.
 - If the separate indoor/outdoor unit power supplied system is applied, refer to Fig. 2.
 - For power supply system of this unit, refer to the caution label located near this diagram.

<Fig. 2>

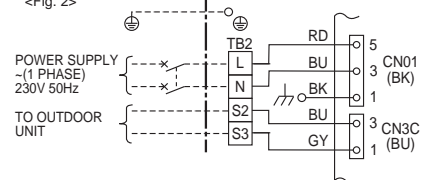

<Fig. 1> Caution when connecting the remote controller cable to the terminal block TB5

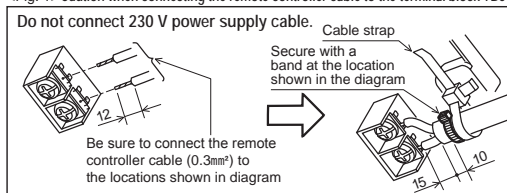

[Self-diagnosis]

1. For details on how to operate self-diagnosis with the wireless remote controller, refer to the technical manuals etc.

Check code	Symptom	Check code	Symptom
P1	Abnormality of room temperature thermistor (TH1).	PB (Pb)	Indoor unit fan motor error.
P2	Abnormality of pipe temperature thermistor / Liquid (TH2).	PL	Refrigerant circuit abnormal.
P4	Float switch connector open (FS).	E0-E5	Abnormality of the signal transmission between remote controller and indoor unit.
P5	Malfunction of Drain pump.	E6-EF	Abnormality of the signal transmission between indoor unit and outdoor unit.
P6	Freezing / overheating protection is working.	FB (Fb)	Abnormality of indoor controller board.
P8	Abnormality of pipe temperature.	U*, F*	Abnormality in outdoor unit. Refer to outdoor unit wiring diagram.
P9	Abnormality of pipe temperature thermistor / Cond. /Eva. (TH5).		
PA	Leakage error (refrigerant system)		

PLA-RP35EA.UK
PLA-RP71EA.UK

PLA-RP50EA.UK
PLA-RP100EA.UK

PLA-RP60EA.UK
PLA-RP125EA.UK

PLA-RP140EA.UK

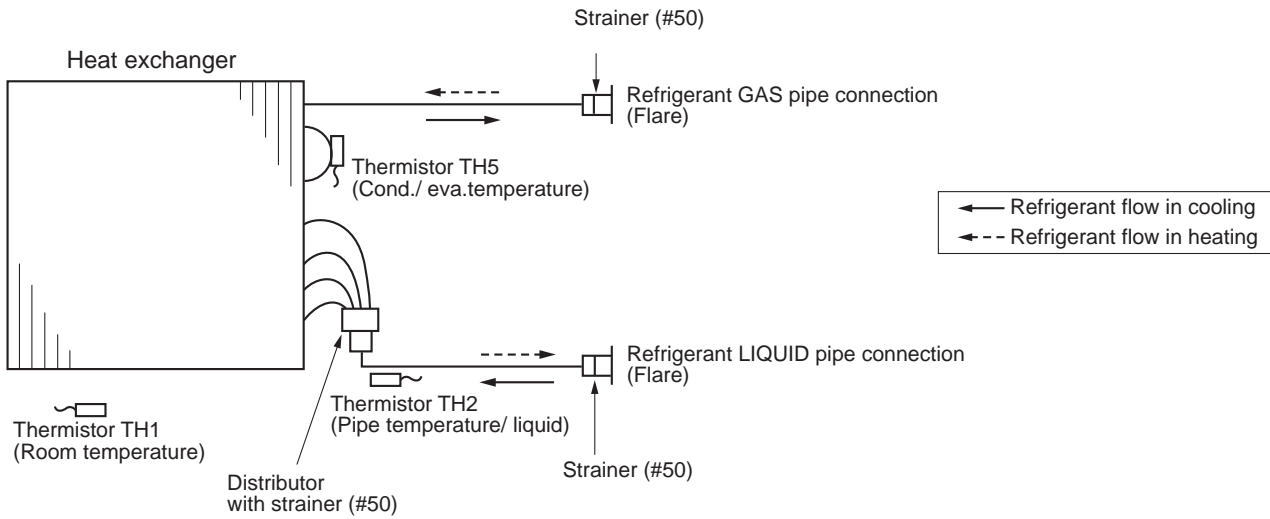

9-1. TROUBLESHOOTING

<Check code displayed by self-diagnosis and actions to be taken for service (summary)>

Present and past check codes are logged, and they can be displayed on the wired remote controller or controller board of outdoor unit. Actions to be taken for service, which depends on whether or not the trouble is reoccurring in the field, are summarized in the table below. Check the contents below before investigating details.

Unit conditions at service	Check code	Actions to be taken for service (summary)
The trouble is reoccurring.	Displayed	Judge what is wrong and take a corrective action according to "9-3. SELF-DIAGNOSIS ACTION TABLE".
	Not displayed	Conduct troubleshooting and ascertain the cause of the trouble according to "9-4. TROUBLESHOOTING OF PROBLEMS".
The trouble is not reoccurring.	Logged	① Consider the temporary defects such as the work of protection devices in the refrigerant circuit including compressor, poor connection of wiring, noise, etc. Re-check the symptom, and check the installation environment, refrigerant amount, weather when the trouble occurred, matters related to wiring, etc. ② Reset check code logs and restart the unit after finishing service. ③ There is no abnormality in electrical component, controller board, remote controller, etc.
	Not logged	① Re-check the abnormal symptom. ② Conduct troubleshooting and ascertain the cause of the trouble according to "9-4. TROUBLESHOOTING OF PROBLEMS". ③ Continue to operate unit for the time being if the cause is not ascertained. ④ There is no abnormality concerning of parts such as electrical component, controller board, remote controller, etc.

9-2. MALFUNCTION-DIAGNOSIS METHOD BY REMOTE CONTROLLER

<In case of trouble during operation>

When a malfunction occurs to air conditioner, both indoor unit and outdoor unit will stop and operation lamp blinks to inform unusual stop.

<Self-check>

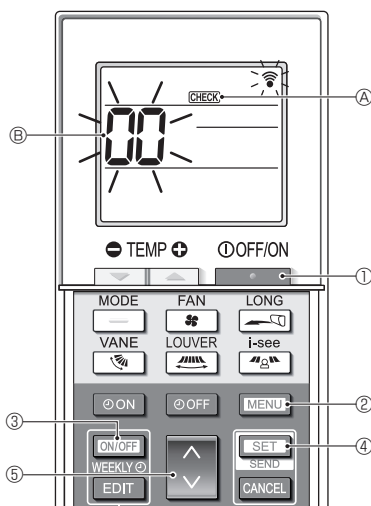

- Press the **ON/OFF** button ① to stop the air conditioner.
 - If the weekly timer is enabled (**WEEKLY** is on), press the **ON/OFF WEEKLY** button ③ to disable it (**WEEKLY** is off).
- Press the **MENU** button ② for 5 seconds.
 - CHECK** ④ comes on and the unit enters the self-check mode.
- Press the **DOWN** button ⑤ to select the refrigerant address (M-NET address) ⑥ of the indoor unit for which you want to perform the self-check.
- Press the **SET** button ④.
 - If an error is detected, the check code is indicated by the number of beeps from the indoor unit and the number of blinks of the OPERATION INDICATOR lamp.
- Press the **ON/OFF** button ①.
 - CHECK** ④ and the refrigerant address (M-NET address) ⑥ go off and the self-check is completed.

Refer to the following tables for details on the check codes.

[Output pattern A]

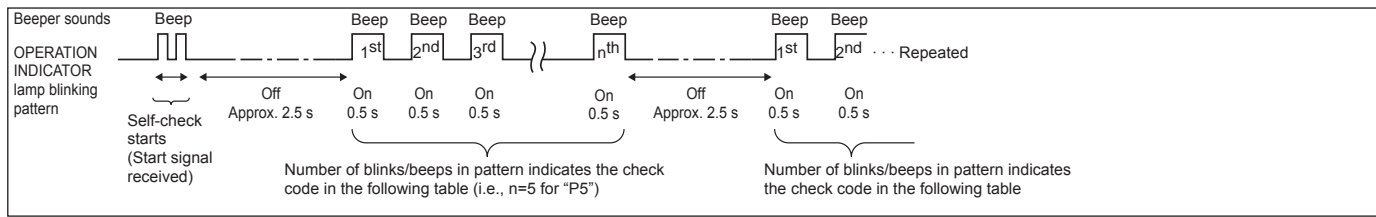

[Output pattern B]

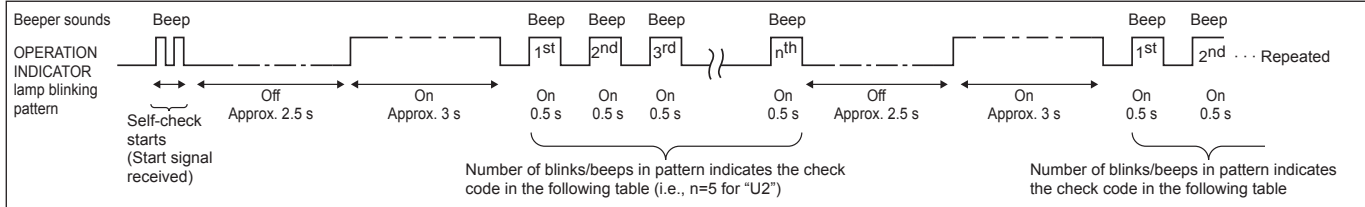

[Output pattern A] Errors detected by indoor unit

Wireless remote controller	Wired remote controller	Symptom	Remark
Beeper sounds/OPERATION INDICATOR lamp blinks (Number of times)	Check code		
1	P1	Intake sensor error	
2	P2	Pipe (TH2) sensor error	
	P9	Pipe (TH5) sensor error	
3	E6, E7	Indoor/indoor unit communication error	
4	P4	Drain sensor error / Float switch connector open	
5	P5	Drain overflow protection operation	
	PA	Forced compressor error (due to water leakage abnormality)	
6	P6	Freeze (during cooling operation)/Overheat protection operation (during heating operation)	
7	EE	Communication error between indoor and outdoor unit	
8	P8	Pipe temperature error	
9	E4, E5	Communication error between wired remote controller and indoor unit	
10	—	—	
11	Pb	Indoor unit fan motor error	
12	Fb	Indoor unit control system error (memory error, etc.)	
14	PL	Refrigerant circuit abnormal	
—	E0,E3	Remote controller transmission error	
—	E1,E2	Remote controller control board error	

[Output pattern B] Errors detected by unit other than indoor unit (outdoor unit, etc.)

Note: The supported check codes may vary depending on the connected outdoor unit.

Wireless remote controller	Wired remote controller	Symptom	Remark
Beeper sounds/OPERATION INDICATOR lamp blinks (Number of times)	Check code		
1	E9	Indoor/outdoor unit communication error	For details, check the LED display of the outdoor controller board.
2	UP	Compressor overcurrent interruption	
3	U3, U4	Open/short of outdoor unit thermistors	
4	UF	Compressor overcurrent interruption (When compressor locked)	
5	U2	Abnormal high discharging temperature/49C worked/insufficient refrigerant	
6	U1, Ud	Abnormal high pressure (63H worked)/Overheat protection operation	
7	U5	Abnormal temperature of heat sink	
8	U8	Outdoor unit fan protection stop	
9	U6	Compressor overcurrent interruption/Abnormal of power module	
10	U7	Abnormality of super heat due to low discharge temperature	
11	U9, UH	Abnormality such as overvoltage or voltage shortage and abnormal synchronous signal to main circuit/Current sensor error	
12	—	—	
13	—	—	
14	Others	Other errors (Refer to the technical manual for the outdoor unit.)	

Notes:

- If the beeper does not sound again after the initial 2 beeps to confirm the self-check start signal was received and the OPERATION INDICATOR lamp does not come on, there are no error records.
- If the beeper sounds 3 times continuously "beep, beep, beep (0.4 + 0.4 + 0.4 seconds)" after the initial 2 beeps to confirm the self-check start signal was received, the specified refrigerant address is incorrect.
 - On wireless remote controller
 - The continuous buzzer sounds from receiving section of indoor unit.
 - Blink of operation lamp
 - On wired remote controller
 - Check code displayed in the LCD.

Continued to the next page

- If the unit cannot be operated properly after the test run, refer to the following table to find out the cause.

Symptom		Cause
Wired remote controller		
PLEASE WAIT	For about 2 minutes after power-on	• For about 2 minutes after power-on, operation of the remote controller is not possible due to system startup. (Correct operation)
PLEASE WAIT → check code	Subsequent to about 2 minutes after power-on	• Connector for the outdoor unit's protection device is not connected. • Reverse or open phase wiring for the outdoor unit's power terminal block
No messages appear even when operation switch is turned ON (operation lamp does not light up).		• Incorrect wiring between indoor and outdoor units. (incorrect polarity of S1, S2, S3) • Remote controller wire short

On the wireless remote controller with condition above, following phenomena take place.

- No signals from the remote controller can be received.
- Operation lamp is blinking.
- The buzzer makes a short ping sound.

Note:

Operation is not possible for about 30 seconds after cancellation of function selection. (Correct operation)

For description of each LED (LED1, 2, 3) provided on the indoor controller, refer to the following table.

LED1 (power for microprocessor)	Indicates whether control power is supplied. Make sure that this LED is always lit.
LED2 (power for remote controller)	Indicates whether power is supplied to the remote controller. This LED lights only in the case of the indoor unit which is connected to the outdoor unit refrigerant address "0".
LED3 (communication between indoor and outdoor units)	Indicates state of communication between the indoor and outdoor units. Make sure that this LED is always blinking.

Note: Errors to be detected in outdoor unit, such as codes starting with F, U or E (excluding E0 to E7), are not covered in this document. Please refer to the outdoor unit's service manual for the details.

9-3. SELF-DIAGNOSIS ACTION TABLE

Check code	Abnormal point and detection method	Cause	Countermeasure										
P1	<p>Room temperature thermistor (TH1)</p> <p>① The unit is in 3-minute resume prevention mode if short/open of thermistor is detected. Abnormal if the unit does not reset normally after 3 minutes. (The unit returns to normal operation, if it has been reset normally.)</p> <p>② Constantly detected during cooling, drying, and heating operation. Short: -90°C or more Open: -40°C or less</p>	<p>① Defective thermistor characteristics</p> <p>② Contact failure of connector (CN20) on the indoor controller board (Insert failure)</p> <p>③ Breaking of wire or contact failure of thermistor wiring</p> <p>④ Defective indoor controller board</p>	<p>①-③ Check resistance value of thermistor.</p> <table border="1"> <tr> <td>0°C</td> <td>15.0 kΩ</td> </tr> <tr> <td>10°C</td> <td>9.6 kΩ</td> </tr> <tr> <td>20°C</td> <td>6.3 kΩ</td> </tr> <tr> <td>30°C</td> <td>4.3 kΩ</td> </tr> <tr> <td>40°C</td> <td>3.0 kΩ</td> </tr> </table> <p>If you put force on (draw or bend) the lead wire while measuring resistance value of thermistor, breaking of wire or contact failure can be detected.</p> <p>② Check contact failure of connector (CN20) on the indoor controller board. Refer to "9-7. TEST POINT DIAGRAM". Turn the power on again and check restart after inserting connector again.</p> <p>④ Check room temperature display on remote controller. Replace indoor controller board if there is abnormal difference with actual room temperature.</p> <p>Turn the power off, and on again to operate after check.</p>	0°C	15.0 kΩ	10°C	9.6 kΩ	20°C	6.3 kΩ	30°C	4.3 kΩ	40°C	3.0 kΩ
0°C	15.0 kΩ												
10°C	9.6 kΩ												
20°C	6.3 kΩ												
30°C	4.3 kΩ												
40°C	3.0 kΩ												
P2	<p>Pipe temperature thermistor/Liquid (TH2)</p> <p>① The unit is in 3-minute resume prevention mode if short/open of thermistor is detected. Abnormal if the unit does not reset normally after 3 minutes. (The unit returns to normal operation, if it has been reset normally.)</p> <p>② Constantly detected during cooling, drying, and heating (except defrosting) operation Short: 90°C or more Open: -40°C or less</p>	<p>① Defective thermistor characteristics</p> <p>② Contact failure of connector (CN44) on the indoor controller board (Insert failure)</p> <p>③ Breaking of wire or contact failure of thermistor wiring</p> <p>④ Defective refrigerant circuit is causing thermistor temperature of 90°C or more or -40°C or less.</p> <p>⑤ Defective indoor controller board</p>	<p>①-③ Check resistance value of thermistor. For characteristics, refer to (P1) above.</p> <p>② Check contact failure of connector (CN44) on the indoor controller board. Refer to "9-7. TEST POINT DIAGRAM". Turn the power on and check restart after inserting connector again.</p> <p>④ Check pipe <liquid> temperature with remote controller in test run mode. If pipe <liquid> temperature is extremely low (in cooling mode) or high (in heating mode), refrigerant circuit may have defective.</p> <p>⑤ Check pipe <liquid> temperature with remote controller in test run mode. If there is extremely difference with actual pipe <liquid> temperature, replace indoor controller board.</p> <p>Turn the power off, and on again to operate after check.</p>										
P4	<p>Contact failure of drain float switch (CN4F)</p> <ul style="list-style-type: none"> • Extract when the connector of drain float switch is disconnected. (③ and ④ of connector CN4F is not short-circuited.) • Constantly detected during operation 	<p>① Contact failure of connector (Insert failure)</p> <p>② Defective indoor controller board</p>	<p>① Check contact failure of float switch connector. Turn the power on again and check after inserting connector again.</p> <p>② Operate with connector (CN4F) short-circuited. Replace indoor controller board if abnormality reappears.</p>										
P5	<p>Drain over flow protection operation</p> <p>① Suspensive abnormality, if drain float switch is detected to be underwater for 1 minute and 30 seconds continuously with drain pump on. Compressor and indoor fan will be turned off.</p> <p>② Drain pump is abnormal if the condition above is detected during suspensive abnormality.</p> <p>③ Constantly detected during drain pump operation</p>	<p>① Malfunction of drain pump</p> <p>② Defective drain Clogged drain pump Clogged drain pipe</p> <p>③ Defective drain float switch Jamming of the drain float switch or malfunction of moving parts causing the drain float switch to be detected under water (Switch On)</p> <p>④ Defective indoor-controller board</p>	<p>① Check if drain pump works.</p> <p>② Check drain function.</p> <p>③ Remove drain float switch connector CN4F and check if it is short (Switch On) with the moving part of float switch UP, or OPEN with the moving part of float switch down. Replace float switch if it is short with the moving part of float switch down.</p> <p>④ Replace indoor controller board if it is short-circuited between ③-④ of the drain float switch connector CN4F and abnormality reappears.</p> <p>It is not abnormal if there is no problem about the above-mentioned ①-④. Turn the power off, and on again to operate after check.</p>										



Check code	Abnormal point and detection method	Cause	Countermeasure
P5	<p>Drain pump lock protection operation</p> <p>① Error postponement, if drain pump stops for 5 seconds continuously while drain pump is operating.</p> <p>② Drain pump is abnormal if above condition is repeated 4 times after error postponement is detected.</p>	<p>① Malfunction of drain pump</p> <p>② Clogged drain pump</p> <p>③ Contact failure of connector</p> <p>④ Defective indoor controller board</p>	<p>① Check if drain pump works.</p> <p>② Check if drain pump works.</p> <p>③ Check contact failure of connector CNP</p> <p>④ Press the indoor emergency switch (SWE) to check the voltage between CNP①-③.</p> <p>•If 13 V DC, change the drain pump. •If not 13 V DC, change the indoor controller board.</p>
P6	<p>Freeze/overheat protection is operating</p> <p>① Freeze protection (Cooling mode) The unit is in 6-minute resume prevention mode if pipe <liquid or condenser/evaporator> temperature stays under -15°C for 3 minutes, 3 minutes after the compressor started. Abnormal if it stays under -15°C for 3 minutes again within 16 minutes after 6-minute resume prevention mode.</p> <p>② Overheat protection (Heating mode) The unit is in 6-minute resume prevention mode if pipe <liquid or condenser/evaporator> temperature is detected as over 70°C after the compressor started. Abnormal if the temperature of over 70°C is detected again within 30 minutes after 6-minute resume prevention mode.</p>	<p>(Cooling or drying mode)</p> <p>① Clogged filter (reduced airflow)</p> <p>② Short cycle of air path</p> <p>③ Low-load (low temperature) operation out of the tolerance range</p> <p>④ Defective indoor fan motor • Fan motor is defective. • Indoor controller board is defective.</p> <p>⑤ Defective outdoor fan control</p> <p>⑥ Overcharge of refrigerant</p> <p>⑦ Defective refrigerant circuit (clogs)</p> <p>(Heating mode)</p> <p>① Clogged filter (reduced airflow)</p> <p>② Short cycle of air path</p> <p>③ Over-load (high temperature) operation out of the tolerance range</p> <p>④ Defective indoor fan motor • Fan motor is defective. • Indoor controller board is defective.</p> <p>⑤ Defective outdoor fan control</p> <p>⑥ Overcharge of refrigerant</p> <p>⑦ Defective refrigerant circuit (clogs)</p> <p>⑧ Bypass circuit of outdoor unit is defective.</p>	<p>(Cooling or drying mode)</p> <p>① Check clogs of the filter.</p> <p>② Remove blockage.</p> <p>④ Refer to "9-6. HOW TO CHECK THE PARTS".</p> <p>⑤ Check outdoor fan motor.</p> <p>⑥⑦ Check operating condition of refrigerant circuit.</p> <p>(Heating mode)</p> <p>① Check clogs of the filter.</p> <p>② Remove blockage.</p> <p>④ Refer to "9-6. HOW TO CHECK THE PARTS".</p> <p>⑤ Check outdoor fan motor.</p> <p>⑥-⑧ Check operating condition of refrigerant circuit.</p>
P8	<p>Pipe temperature <Cooling mode> Detected as abnormal when the pipe temperature is not in the cooling range 3 minutes after compressor start and 6 minutes after the liquid or condenser/evaporator pipe is out of cooling range. Note 1: It takes at least 9 minutes to detect. Note 2: Abnormality P8 is not detected in drying mode. Cooling range : -3°C ≧ (TH-TH1) TH: Lower temperature between liquid pipe temperature (TH2) and condenser/evaporator temperature (TH5) TH1: Intake temperature</p> <p><Heating mode> When 10 seconds have passed after the compressor starts operation and the hot adjustment mode has finished, the unit is detected as abnormal when condenser/evaporator pipe temperature is not in heating range within 20 minutes.</p> <p>Note 3: It takes at least 27 minutes to detect abnormality. Note 4: It excludes the period of defrosting. (Detection restarts when defrosting mode is over.) Heating range : 3°C ≦ (TH5-TH1)</p>	<p>① Slight temperature difference between indoor room temperature and pipe <liquid or condenser/evaporator> temperature thermistor • Shortage of refrigerant • Disconnected holder of pipe <liquid or condenser/evaporator> thermistor • Defective refrigerant circuit</p> <p>② Converse connection of extension pipe (on plural units connection)</p> <p>③ Converse wiring of indoor/outdoor unit connecting wire (on plural units connection)</p> <p>④ Defective detection of indoor room temperature and pipe <condenser/evaporator> temperature thermistor</p> <p>⑤ Stop valve is not opened completely.</p>	<p>①-④ Check pipe <liquid or condenser/evaporator> temperature with room temperature display on remote controller and outdoor controller circuit board. Pipe <liquid or condenser/evaporator> temperature display is indicated by setting SW2 of outdoor controller circuit board as follows.</p> <p>(Conduct temperature check with outdoor controller circuit board after connecting 'A-Control Service Tool(PAC-SK52ST)').</p> <p>②③ Check converse connection of extension pipe or converse wiring of indoor/outdoor unit connecting wire.</p>



Check code	Abnormal point and detection method	Cause	Countermeasure
P9	<p>Pipe temperature thermistor/ Condenser-Evaporator (TH5)</p> <p>① The unit is in 3-minute resume protection mode if short/open of thermistor is detected. Abnormal if the unit does not get back to normal within 3 minutes. (The unit returns to normal operation, if it has been reset normally.)</p> <p>② Constantly detected during cooling, drying, and heating operation (except defrosting) Short: 90°C or more Open: -40°C or less</p>	<p>① Defective thermistor characteristics</p> <p>② Contact failure of connector (CN44) on the indoor controller board (Insert failure)</p> <p>③ Breaking of wire or contact failure of thermistor wiring</p> <p>④ Temperature of thermistor is 90°C or more or -40°C or less caused by defective refrigerant circuit.</p> <p>⑤ Defective indoor controller board</p>	<p>①-③ Check resistance value of thermistor. For characteristics, refer to (P1) above.</p> <p>② Check contact failure of connector (CN44) on the indoor controller board. Refer to "9-7. TEST POINT DIAGRAM". Turn the power on and check restart after inserting connector again.</p> <p>④ Operate in test run mode and check pipe <condenser/evaporator> temperature with outdoor controller circuit board. If pipe <condenser/evaporator> temperature is extremely low (in cooling mode) or high (in heating mode), refrigerant circuit may have defect.</p> <p>⑤ Operate in test run mode and check pipe <condenser/evaporator> temperature with outdoor control circuit board. If there is extreme difference with actual pipe <condenser / evaporator> temperature, replace indoor controller board. There is no abnormality if none of above comes within the unit. Turn the power off, and on again to operate.</p> <p>(In case of checking pipe temperature with outdoor controller circuit board, be sure to connect A-control service tool (PAC-SK52ST).)</p>
E0 or E4	<p>Remote controller transmission error(E0)/signal receiving error(E4)</p> <p>① Abnormal if main or sub remote controller cannot receive any transmission normally from indoor unit of refrigerant address "0" for 3 minutes. (Check code : E0)</p> <p>② Abnormal if sub remote controller could not receive any signal for 2 minutes. (Check code: E0)</p> <p>① Abnormal if indoor controller board cannot receive any data normally from remote controller board or from other indoor controller board for 3 minutes. (Check code: E4)</p> <p>② Indoor controller board cannot receive any signal from remote controller for 2 minutes. (Check code: E4)</p>	<p>① Contact failure at transmission wire of remote controller</p> <p>② All remote controllers are set as "sub" remote controller. In this case, E0 is displayed on remote controller, and E4 is displayed at LED (LED1, LED2) on the outdoor controller circuit board.</p> <p>③ Miswiring of remote controller</p> <p>④ Defective transmitting receiving circuit of remote controller</p> <p>⑤ Defective transmitting receiving circuit of indoor controller board of refrigerant addresses "0".</p> <p>⑥ Noise has entered into the transmission wire of remote controller.</p>	<p>① Check disconnection or looseness of indoor unit or transmission wire of remote controller.</p> <p>② Set one of the remote controllers "main" if there is no problem with the action above.</p> <p>③ Check wiring of remote controller.</p> <ul style="list-style-type: none"> • Total wiring length: max. 500m (Do not use cable x 3 or more.) • The number of connecting indoor units: max. 16 units • The number of connecting remote controller: max. 2 units <p>When it is not the above-mentioned problem of ①-③</p> <p>④ Diagnose remote controllers.</p> <p>a) When "RC OK" is displayed, Remote controllers have no problem. Turn the power off, and on again to check. If abnormality generates again, replace indoor controller board.</p> <p>b) When "RC NG" is displayed, Replace remote controller.</p> <p>c) When "RC E3" or "ERC 00-66" is displayed, noise may be causing abnormality.</p> <p>Note: If the unit is not normal after replacing indoor controller board in group control, indoor controller board of address "0" may be abnormal.</p>
E3 or E5	<p>Remote controller transmission error(E3)/signal receiving error(E5)</p> <p>① Abnormal if remote controller could not find blank of transmission path for 6 seconds and could not transmit. (Check code: E3)</p> <p>② Remote controller receives transmitted data at the same time and compares the received and transmitted data. Abnormal if these data are judged to be different 30 continuous times. (Check code: E3)</p> <p>① Abnormal if indoor controller board could not find blank of transmission path. (Check code: E5)</p> <p>② Indoor controller board receives transmitted data at the same time and compares the received and transmitted data. Abnormal if these data are judged to be different 30 continuous times. (Check code: E5)</p>	<p>① 2 remote controllers are set as "main." (In case of 2 remote controllers)</p> <p>② Remote controller is connected with 2 indoor units or more.</p> <p>③ Repetition of refrigerant address</p> <p>④ Defective transmitting receiving circuit of remote controller</p> <p>⑤ Defective transmitting receiving circuit of indoor controller board</p> <p>⑥ Noise has entered into transmission wire of remote controller.</p>	<p>① Set a remote controller to main, and the other to sub.</p> <p>② Remote controller is connected with only one indoor unit.</p> <p>③ The address changes to a separate setting.</p> <p>④-⑥ Diagnose remote controller.</p> <p>a) When "RC OK" is displayed, remote controllers have no problem. Turn the power off, and on again to check. When becoming abnormal again, replace indoor controller board.</p> <p>b) When "RC NG" is displayed, replace remote controller.</p> <p>c) When "RC E3" or "ERC 00-66" is displayed, noise may be causing abnormality.</p>



Check code	Abnormal point and detection method	Cause	Countermeasure
E6	<p>Indoor/outdoor unit communication error (Signal receiving error)</p> <p>① Abnormal if indoor controller board cannot receive any signal normally for 6 minutes after turning the power on.</p> <p>② Abnormal if indoor controller board cannot receive any signal normally for 3 minutes.</p> <p>③ Consider the unit abnormal under the following condition: When 2 or more indoor units are connected to an outdoor unit, indoor controller board cannot receive a signal for 3 minutes from outdoor controller circuit board, a signal which allows outdoor controller circuit board to transmit signals.</p>	<p>① Contact failure, short circuit or, miswiring (converse wiring) of indoor/outdoor unit connecting wire</p> <p>② Defective transmitting receiving circuit of indoor controller board</p> <p>③ Defective transmitting receiving circuit of indoor controller board</p> <p>④ Noise has entered into indoor/outdoor unit connecting wire.</p> <p>⑤ Malfunction of fan motor</p>	<p>Note: Check LED display on the outdoor control circuit board. (Connect A-control service tool, PAC-SK52ST.) Refer to outdoor unit service manual.</p> <p>① Check disconnection or looseness of indoor/outdoor unit connecting wire of indoor unit or outdoor unit. Check all the units in case of twin triple indoor unit system.</p> <p>②-④ Turn the power off, and on again to check. If abnormality generates again, replace indoor controller board or outdoor controller circuit board.</p> <p>⑤ Turn the power off, and on again after removing the fan motor connectors (CNF1,2) from outdoor controller board.</p> <ul style="list-style-type: none"> • If normal, change fan motor. • If abnormal reappears, change outdoor controller board. <p>Note: Other indoor controller board may have defect in the case of twin triple indoor unit system.</p>
E7	<p>Indoor/outdoor unit communication error (Transmitting error)</p> <p>Abnormal if "1" receiving is detected 30 times continuously though indoor controller board has transmitted "0".</p>	<p>① Defective transmitting receiving circuit of indoor controller board</p> <p>② Noise has entered into power supply.</p> <p>③ Noise has entered into outdoor control wire.</p>	<p>①-③ Turn the power off, and on again to check. If abnormality generates again, replace indoor controller board.</p>
Fb	<p>Indoor controller board</p> <p>Abnormal if data cannot be read normally from the nonvolatile memory of the indoor controller board.</p>	<p>① Defective indoor controller board</p>	<p>① Replace indoor controller board.</p>
E1 or E2	<p>Remote controller control board</p> <p>① Abnormal if data cannot be read normally from the nonvolatile memory of the remote controller control board. (Check code: E1)</p> <p>② Abnormal if the clock function of remote controller cannot be operated normally. (Check code: E2)</p>	<p>① Defective remote controller</p>	<p>① Replace remote controller.</p>
PA	<p>Forced compressor stop (due to water leakage abnormality)</p> <p>① The unit has a water leakage abnormality when the following conditions, a) and b), are satisfied while the above-mentioned detection is performed.</p> <p>a) The intake temperature subtracted with liquid pipe temperature detects to be less than -10°C for a total of 30 minutes. (When the drain sensor is detected to be NOT soaked in the water, the detection record of a) and b) will be cleared.)</p> <p>b) Drain float switch detects to be in the water for more than 15 minutes.</p> <p>Note: Once the water leakage abnormality is detected, abnormality state will not be released until the main power is reset.</p>	<p>① Drain pump trouble</p> <p>② Drain defective</p> <ul style="list-style-type: none"> • Drain pump clogging • Drain pipe clogging <p>③ Open circuit of float switch</p> <p>④ Contact failure of float switch connector</p> <p>⑤ Dew condensation on float switch</p> <ul style="list-style-type: none"> • Drain water descends along lead wire. • Drain water is waving due to filter clogging. <p>⑥ Extension piping connection difference at twin, triple or quadruple system</p> <p>⑦ Miswiring of indoor/outdoor connecting at twin, triple or quadruple system</p> <p>⑧ Room temperature thermistor/liquid pipe temperature thermistor detection is defective.</p>	<p>① Check the drain pump.</p> <p>② Check whether water can be drained.</p> <p>③ Check the resistance of the float switch.</p> <p>④ Check the connector contact failure.</p> <p>⑤ Check the float switch leadwire mounted. Check the filter clogging.</p> <p>⑥ Check the piping connection.</p> <p>⑦ Check the indoor/outdoor connecting wires.</p> <p>⑧ Check the room temperature display of remote controller. Check the indoor liquid pipe temperature display of outdoor controller board.</p>



Check code	Abnormal point and detection method	Cause	Countermeasure
Pb	Fan motor trouble	① Defective fan motor ② Defective indoor controller board	①② Refer to "9-6-2. DC Fan Motor (Fan Motor/ Indoor Controller Board".)
PL	Abnormal refrigerant circuit During Cooling, Dry, or Auto Cooling operation, the following conditions are regarded as failures when detected for 1 second. a)The compressor continues to run for 30 or more seconds. b)The liquid pipe temperature or the condenser/evaporator temperature is 75°C or more. <u>These detected errors will not be cancelled until the power source is reset.</u>	① Abnormal operation of 4-way valve ② Disconnection of or leakage in refrigerant pipes ③ Air into refrigerant piping ④ Abnormal operation (no rotation) of indoor fan <ul style="list-style-type: none"> • Defective fan motor • Defective indoor control board. ⑤ Defective refrigerant circuit (clogging)	① <u>When this error occurs, be sure to replace the 4-way valve.</u> ② Check refrigerant pipes for disconnection or leakage. ③ After the recovery of refrigerant, vacuum dry the whole refrigerant circuit. ④ Refer to section "9-6-2. DC Fan motor (FAN MOTOR/INDOOR CONTROLLER BOARD)". ⑤ Check refrigerant circuit for operation. <u>To avoid entry of moisture or air into refrigerant circuit which could cause abnormal high pressure, purge air in refrigerant circuit or replace refrigerant.</u>

9-4. TROUBLESHOOTING OF PROBLEMS

Note: Refer to the outdoor unit's service manual for the detail of remote controller.

Phenomena	Cause	Countermeasure
<p>(1) LED2 on indoor controller board is off.</p>	<ul style="list-style-type: none"> • When LED1 on indoor controller board is also off. ① Power supply of rated voltage is not supplied to outdoor unit. ② Defective outdoor controller circuit board ③ Power supply of 220–240 V is not supplied to indoor unit. ④ Defective indoor controller board <p>(For the separate indoor/outdoor unit power supply system)</p> <ul style="list-style-type: none"> ① Power supply of 220–240 V AC is not supplied to indoor unit. ② The connectors of the optional replacement kit are not used. ③ Defective indoor controller board 	<ul style="list-style-type: none"> ① Check the voltage of outdoor power supply terminal block (L, N) or (L₃, N). <ul style="list-style-type: none"> • When 220–240 V AC is not detected, check the power wiring to outdoor unit and the breaker. • When 220–240 V AC is detected, check ② (below). ② Check the voltage between outdoor terminal block S1 and S2. <ul style="list-style-type: none"> • When 220–240 V AC is not detected, —check the fuse on outdoor controller circuit board. —check the wiring connection. • When 220–240 V AC is detected, check ③ (below). ③ Check the voltage between indoor terminal block S1 and S2. <ul style="list-style-type: none"> • When 220–240 V AC is not detected, check indoor/outdoor unit connecting wire for miswiring. • When 220–240 V AC is detected, check ④ (below). ④ Check the fuse on indoor controller board. Check the wiring connection. If no problem is found, indoor controller board is defective. <ul style="list-style-type: none"> ① Check the voltage of indoor power supply terminal block (L,N). <ul style="list-style-type: none"> • When 220–240 V AC is not detected, check the power supply wiring. • When 220–240 V AC is detected, check ② (below). ② Check that there is no problem in the method of connecting the connectors. <ul style="list-style-type: none"> • When there are problems in the method of connecting the connectors, connect the connector correctly referring to installation manual of an optional kit. • When there is no problem in the method of connecting the connectors, check ③ (below). ③ Check the fuse on indoor controller board. Check the wiring connection. If no problem is found, indoor controller board is defective.
	<ul style="list-style-type: none"> • When LED1 on indoor controller board is lit. ① Mis-setting of refrigerant address for outdoor unit (There is no unit corresponding to refrigerant address "0".) 	<ul style="list-style-type: none"> ① Check again the setting of refrigerant address for outdoor unit. Set the refrigerant address to "0". (For grouping control system under which 2 or more outdoor units are connected, set one of the units to "0".) Set refrigerant address using SW1 (3-6) on outdoor controller circuit board.

Note: Refer to the outdoor unit's service manual for the detail of remote controller.

Phenomena	Cause	Countermeasure
(2) LED2 on indoor controller board is blinking.	<ul style="list-style-type: none"> • When LED1 on indoor controller board is also blinking. Connection failure of indoor/outdoor unit connecting wire • When LED1 is lit. ① Miswiring of remote controller wires Under twin triple indoor unit system, 2 or more indoor units are wired together. ② Refrigerant address for outdoor unit is wrong or not set. Under grouping control system, there are some units whose refrigerant addresses are 0. ③ Short-circuit of remote controller wires ④ Defective remote controller 	<p>Check indoor/outdoor unit connecting wire for connection failure.</p> <ul style="list-style-type: none"> ① Check the connection of remote controller wires in case of twin triple indoor unit system. When 2 or more indoor units are wired in one refrigerant system, connect remote controller wires to one of those units. ② Check the setting of refrigerant address in case of grouping control system. If there are some units whose refrigerant addresses are 0 in one group, set one of the units to 0 using SW1 (3-6) on outdoor controller circuit board. ③④ Remove remote controller wires and check LED2 on indoor controller board. <ul style="list-style-type: none"> • When LED2 is blinking, check the short-circuit of remote controller wires. • When LED2 is lit, connect remote controller wires again and: if LED2 is blinking, remote controller is defective; if LED2 is lit, connection failure of remote controller terminal block, etc. has returned to normal.
(3) Upward/downward vane performance failure	<ul style="list-style-type: none"> ① The vane is not downward during defrosting and heat preparation and when the thermostat is OFF in HEAT mode. (Working of COOL protection function) ② Vane motor does not rotate. <ul style="list-style-type: none"> • Defective vane motor • Breaking of wire or connection failure of connector ③ Upward/downward vane does not work. <ul style="list-style-type: none"> • The vane is set to fixed position. 	<ul style="list-style-type: none"> ① Normal operation (The vane is set to horizontal regardless of remote control.) ② Check ② (left). <ul style="list-style-type: none"> • Check the vane motor. (Refer to "9-6. HOW TO CHECK THE PARTS".) • Check for breaking of wire or connection failure of connector. ③ Normal operation (Each connector on vane motor side is disconnected or setting the fixed vanes by wired remote controller.)
(4) Receiver for wireless remote controller	<ul style="list-style-type: none"> ① Weak batteries of wireless remote controller. ② Contact failure of connector (CNB) on wireless remote controller board (Insert failure) ③ Contact failure of connector (CN90) on indoor controller board (Insert failure) ④ Contact failure of connector between wireless remote controller board and indoor controller board 	<ul style="list-style-type: none"> ① Replace batteries of wireless remote controller. ②-④ Check contact failure of each connector. If no problems are found on connector, replace indoor controller board. When the same trouble occurs even if indoor controller board is replaced, replace wireless remote controller board.

9-5. EMERGENCY OPERATION

9-5-1. When wireless remote controller fails or its battery is exhausted

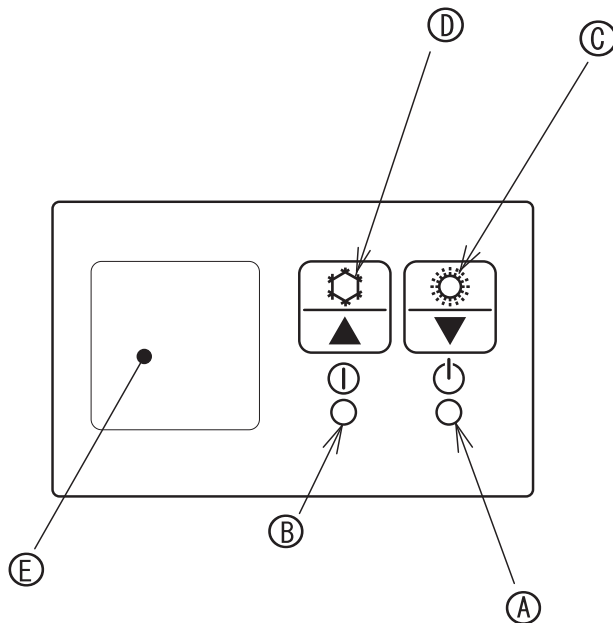

When the remote controller cannot be used

When the batteries of the remote controller run out or the remote controller malfunctions, the emergency operation can be done using the emergency buttons on the grille.

- Ⓐ DEFROST/STAND BY lamp
- Ⓑ Operation lamp
- Ⓒ Emergency operation switch (heating)
- Ⓓ Emergency operation switch (cooling)
- Ⓔ Receiver

Starting operation

- To operate the cooling mode, press the ❄️ button Ⓓ for more than 2 seconds.
- To operate the heating mode, press the ☀️ button Ⓒ for more than 2 seconds.

Note: Lighting of the Operation lamp Ⓑ means the start of operation.

Details of EMERGENCY MODE are as shown below.

Operation mode	COOL	HEAT
Set temperature	24°C	24°C
Fan speed	High	High
Air flow direction	Horizontal	Downward 5

Stopping operation

- To stop operation, press the ❄️ button Ⓓ or the ☀️ button Ⓒ.

9-5-2. When wired remote controller or indoor unit microprocessor fails

[Emergency operation procedure]

1. When the wired remote controller or the indoor unit microcomputer has failed, but all other components work properly, if you set the switch (SWE) on the indoor controller board ON, the indoor unit will begin emergency operation. When emergency operation is activated, the indoor unit operates as follows:
 - (1) Indoor fan is running at high speed.
 - (2) Drain pump is working.
 - Note on the wireless remote controller: When the remote controller does not function, it is possible to activate emergency operation by using the indoor unit emergency operation switch (SW1, SW2 of the wireless signal receiver board). However, if the indoor unit microcomputer has failed, it is necessary to proceed with points 2 and 3 below as in the case of the wired remote controller.
2. When you activate emergency operation of the cooling or heating, you have to set the switch (SWE) on the indoor controller board and activate emergency operation of the outdoor unit. For details on how to activate emergency operation of the outdoor unit, refer to the outdoor unit wiring diagram.
3. Before you activate emergency operation, check the following points:
 - (1) Emergency operation cannot be activated when:
 - The outdoor unit malfunctions.
 - The indoor fan malfunctions.
 - When it has detected the malfunction of drain pump during self-diagnosing.
 - (2) Emergency operation becomes continuous only by switching the power source on/off. ON/OFF on the remote controller or temperature control etc. does not function.
 - (3) Avoid operating for a long time when the outdoor unit begins defrosting while emergency operation of the heating is activated, because it will start to blow cold air.
 - (4) Emergency cooling should be limited to 10 hours maximum (The indoor unit heat exchanger may freeze).
 - (5) After emergency operation has been deactivated, set the switches etc. to their original positions.
 - (6) Movement of the vanes does not work in emergency operation, therefore you have to slowly set them manually to the appropriate positions.

9-6. HOW TO CHECK THE PARTS

PLA-RP35EA.UK
PLA-RP71EA.UK

PLA-RP50EA.UK
PLA-RP100EA.UK

PLA-RP60EA.UK
PLA-RP125EA.UK

PLA-RP140EA.UK

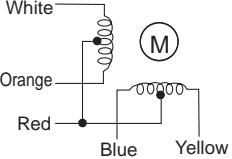
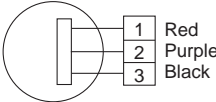
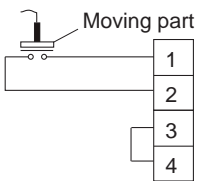
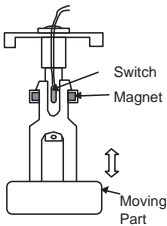
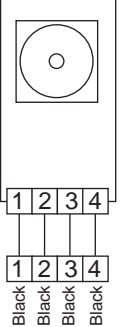
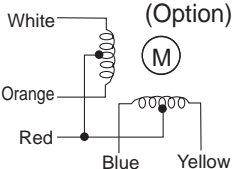
Parts name	Check method and criterion														
Room temperature thermistor (TH1)	Measure the resistance with a tester. (Parts temperature 10 to 30°C)														
Pipe temperature thermistor/liquid (TH2)	<table border="1"> <thead> <tr> <th>Normal</th> <th>Abnormal</th> </tr> </thead> <tbody> <tr> <td>4.3 to 9.6 kΩ</td> <td>Opened or short-circuited</td> </tr> </tbody> </table>	Normal	Abnormal	4.3 to 9.6 kΩ	Opened or short-circuited										
Normal	Abnormal														
4.3 to 9.6 kΩ	Opened or short-circuited														
Condenser/evaporator temperature thermistor (TH5)	Refer to "9-6-1 Thermister".														
Vane motor (MV)	<p>Measure the resistance between the terminals with a tester. (At the ambient temperature 20 to 30°C)</p>  <table border="1"> <thead> <tr> <th>Connector</th> <th>Normal</th> <th>Abnormal</th> </tr> </thead> <tbody> <tr> <td>Red–Yellow (⑤–③, ⑩–⑧, ⑮–⑬, ⑳–⑱)</td> <td rowspan="4">300 Ω</td> <td rowspan="4">Open or short</td> </tr> <tr> <td>Red–Blue (⑤–①, ⑩–⑥, ⑮–⑪, ⑳–⑱)</td> </tr> <tr> <td>Red–Orange (⑤–④, ⑩–⑨, ⑮–⑭, ⑳–⑱)</td> </tr> <tr> <td>Red–White (⑤–②, ⑩–⑦, ⑮–⑫, ⑳–⑱)</td> </tr> </tbody> </table>	Connector	Normal	Abnormal	Red–Yellow (⑤–③, ⑩–⑧, ⑮–⑬, ⑳–⑱)	300 Ω	Open or short	Red–Blue (⑤–①, ⑩–⑥, ⑮–⑪, ⑳–⑱)	Red–Orange (⑤–④, ⑩–⑨, ⑮–⑭, ⑳–⑱)	Red–White (⑤–②, ⑩–⑦, ⑮–⑫, ⑳–⑱)					
Connector	Normal	Abnormal													
Red–Yellow (⑤–③, ⑩–⑧, ⑮–⑬, ⑳–⑱)	300 Ω	Open or short													
Red–Blue (⑤–①, ⑩–⑥, ⑮–⑪, ⑳–⑱)															
Red–Orange (⑤–④, ⑩–⑨, ⑮–⑭, ⑳–⑱)															
Red–White (⑤–②, ⑩–⑦, ⑮–⑫, ⑳–⑱)															
Drain pump (DP)	<ol style="list-style-type: none"> Check if the drain float switch works properly. Check if the drain pump works and drains water properly in cooling operation. If no water drains, confirm that the check code P5 will not be displayed 10 minutes after the operation starts. <p>Note: The drain pump for this model is driven by the internal DC motor of controller board, so it is not possible to measure the resistance between the terminals.</p> <p>Normal Red–Black: Input 13 V DC → The motor starts to rotate. Purple–Black: Abnormal (check code P5) if it outputs 0–13 V square wave (5 pulses/rotation), and the number of rotation is not normal.</p> 														
Drain float switch (FS)	<p>Measure the resistance between the terminals with a tester.</p> <table border="1"> <thead> <tr> <th>State of moving part</th> <th>Normal</th> <th>Abnormal</th> </tr> </thead> <tbody> <tr> <td>UP</td> <td>Short</td> <td>Other than short</td> </tr> <tr> <td>DOWN</td> <td>Open</td> <td>Other than open</td> </tr> </tbody> </table>  	State of moving part	Normal	Abnormal	UP	Short	Other than short	DOWN	Open	Other than open					
State of moving part	Normal	Abnormal													
UP	Short	Other than short													
DOWN	Open	Other than open													
i-see Sensor (Option)	<p>Turn the power ON while the i-see Sensor connector is connected to the CN4Z on indoor controller board. A communication between the indoor controller board and i-see Sensor board is made to detect the connection.</p> <p>Normal: When the operation starts, the motor for i-see Sensor is driven to rotate the i-see Sensor. Abnormal: The motor for i-see Sensor is not driven when the operation starts.</p> <p>Note: The voltage between the terminals cannot be measured accurately since it is pulse output.</p> 														
i-see Sensor motor (Option)	<p>Measure the resistance between the terminals with a tester. (At the ambient temperature 20 to 30°C)</p> <table border="1"> <thead> <tr> <th colspan="4">Normal</th> <th>Abnormal</th> </tr> </thead> <tbody> <tr> <td>Red–Yellow</td> <td>Red–Blue</td> <td>Red–Orange</td> <td>Red–White</td> <td rowspan="2">Open or short</td> </tr> <tr> <td colspan="4">250 Ω</td> </tr> </tbody> </table> 	Normal				Abnormal	Red–Yellow	Red–Blue	Red–Orange	Red–White	Open or short	250 Ω			
Normal				Abnormal											
Red–Yellow	Red–Blue	Red–Orange	Red–White	Open or short											
250 Ω															

9-6-1. Thermistor

<Thermistor Characteristic Graph>

Thermistor for lower temperature

Room temperature thermistor (TH1)
 Pipe temperature thermistor/liquid (TH2)
 Condenser/evaporator temperature thermistor (TH5)

Thermistor $R_0=15k\Omega \pm 3\%$
 Fixed number of $B=3480 \pm 2\%$

$$R_t = 15 \exp \left\{ 3480 \left(\frac{1}{273+t} - \frac{1}{273} \right) \right\}$$

0°C	15 kΩ
10°C	9.6 kΩ
20°C	6.3 kΩ
25°C	5.4 kΩ
30°C	4.3 kΩ
40°C	3.0 kΩ

< Thermistor for lower temperature >

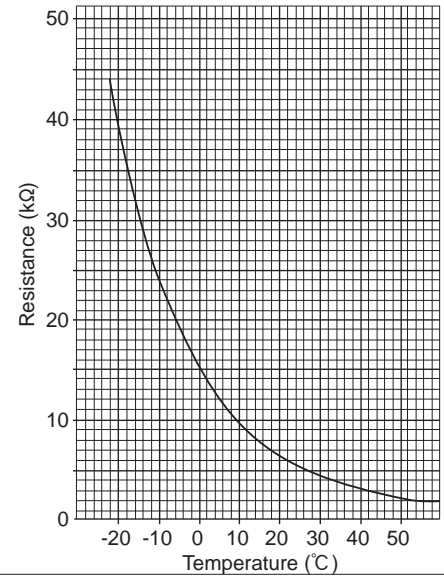

9-6-2. DC Fan motor (FAN MOTOR/INDOOR CONTROLLER BOARD)

Check method of DC fan motor (fan motor / indoor controller circuit board)

① Notes

- High voltage is applied to the connector (CNMF) for the fan motor. Pay attention to the service.
- Do not pull out the connector (CNMF) for the motor with the power supply on.
 (It causes trouble of the indoor controller circuit board and fan motor.)

② Self check

Symptom : The indoor fan cannot turn around.

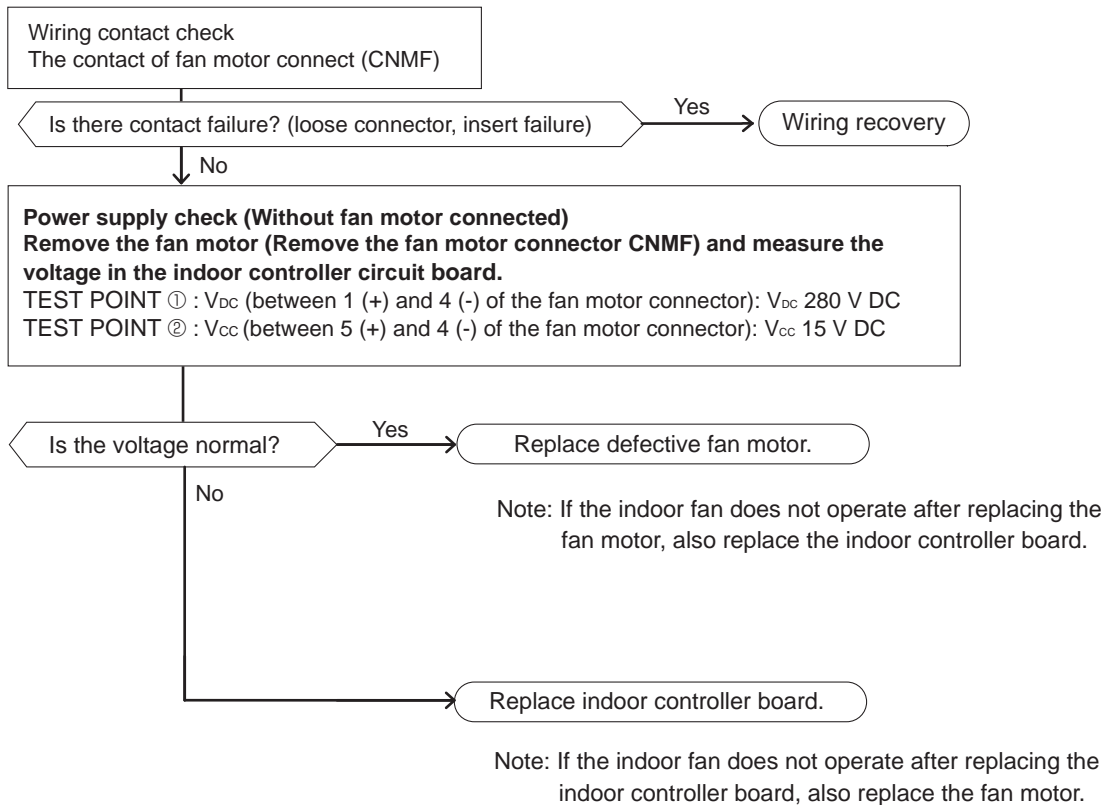

9-7. TEST POINT DIAGRAM

Indoor controller board

PLA-RP35EA.UK
PLA-RP71EA.UK

PLA-RP50EA.UK
PLA-RP100EA.UK

PLA-RP60EA.UK
PLA-RP125EA.UK

PLA-RP140EA.UK

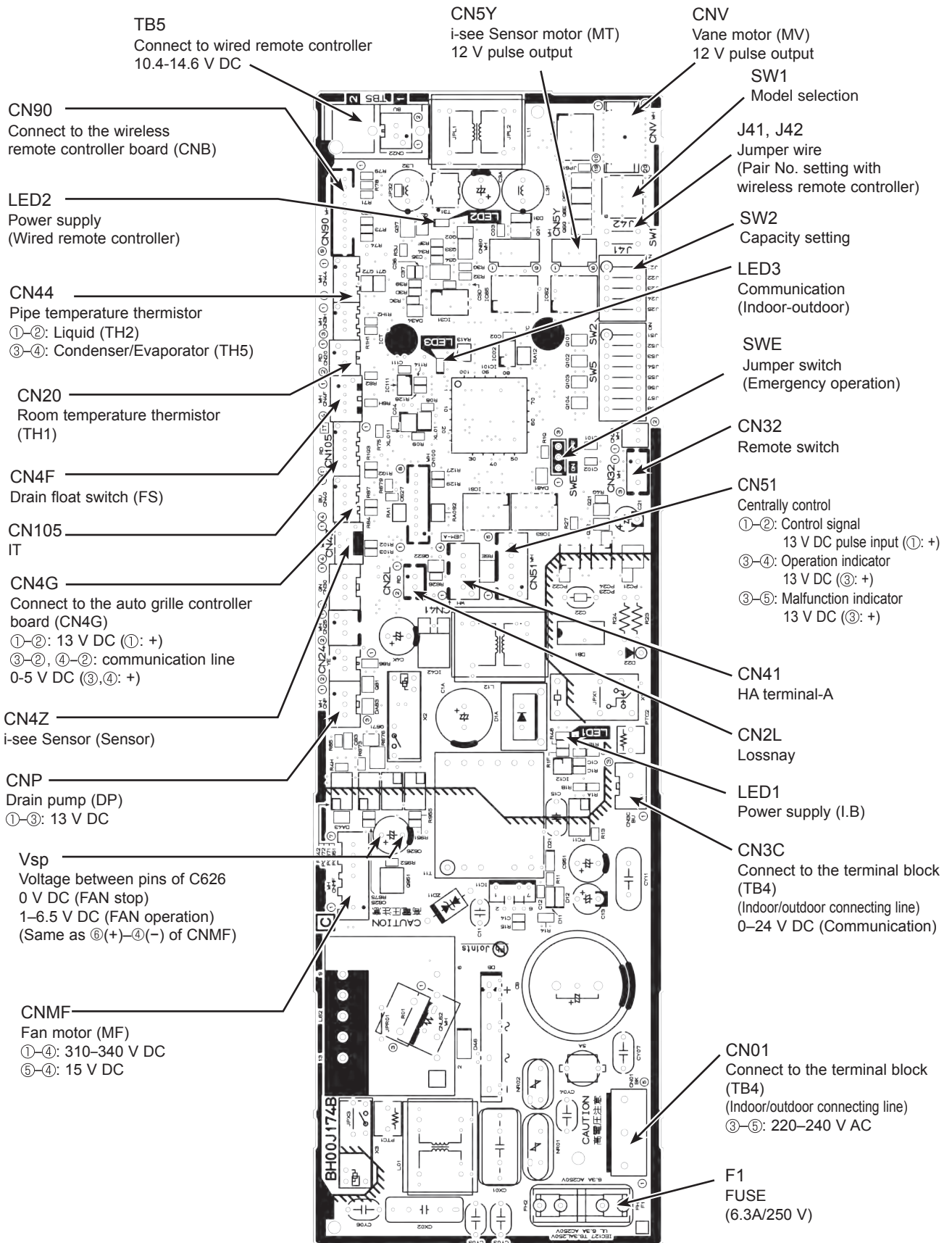

9-8. FUNCTIONS OF DIP SWITCH AND JUMPER WIRE

Each function is controlled by the DIP switch and the jumper wire on the indoor controller board.

The black square (■) indicates a switch position
 Jumper wire (○: Short ×: Open)

Jumper wire	Functions	Setting by the DIP switch and jumper wire	Remarks																																																																																																				
SW1	Model settings	<table border="1"> <thead> <tr> <th>MODEL</th> <th>SETTING</th> </tr> </thead> <tbody> <tr> <td>PLA-RP*EA</td> <td> <table border="1"> <tr> <td>1</td><td>2</td><td>3</td><td>4</td><td>5</td><td>6</td> <td>ON OFF</td> </tr> <tr> <td>■</td><td>■</td><td>■</td><td>■</td><td>■</td><td>■</td> <td></td> </tr> </table> </td> </tr> </tbody> </table>	MODEL	SETTING	PLA-RP*EA	<table border="1"> <tr> <td>1</td><td>2</td><td>3</td><td>4</td><td>5</td><td>6</td> <td>ON OFF</td> </tr> <tr> <td>■</td><td>■</td><td>■</td><td>■</td><td>■</td><td>■</td> <td></td> </tr> </table>	1	2	3	4	5	6	ON OFF	■	■	■	■	■	■																																																																																				
MODEL	SETTING																																																																																																						
PLA-RP*EA	<table border="1"> <tr> <td>1</td><td>2</td><td>3</td><td>4</td><td>5</td><td>6</td> <td>ON OFF</td> </tr> <tr> <td>■</td><td>■</td><td>■</td><td>■</td><td>■</td><td>■</td> <td></td> </tr> </table>	1	2	3	4	5	6	ON OFF	■	■	■	■	■	■																																																																																									
1	2	3	4	5	6	ON OFF																																																																																																	
■	■	■	■	■	■																																																																																																		
SW2	Capacity settings	<table border="1"> <thead> <tr> <th>MODELS</th> <th>SETTING</th> </tr> </thead> <tbody> <tr> <td>PLA-RP35EA</td> <td> <table border="1"> <tr> <td>1</td><td>2</td><td>3</td><td>4</td><td>5</td> <td>ON OFF</td> </tr> <tr> <td>■</td><td>■</td><td>■</td><td>■</td><td>■</td> <td></td> </tr> </table> </td> </tr> <tr> <td>PLA-RP50EA</td> <td> <table border="1"> <tr> <td>1</td><td>2</td><td>3</td><td>4</td><td>5</td> <td>ON OFF</td> </tr> <tr> <td>■</td><td>■</td><td>■</td><td>■</td><td>■</td> <td></td> </tr> </table> </td> </tr> <tr> <td>PLA-RP60EA</td> <td> <table border="1"> <tr> <td>1</td><td>2</td><td>3</td><td>4</td><td>5</td> <td>ON OFF</td> </tr> <tr> <td>■</td><td>■</td><td>■</td><td>■</td><td>■</td> <td></td> </tr> </table> </td> </tr> <tr> <td>PLA-RP71EA</td> <td> <table border="1"> <tr> <td>1</td><td>2</td><td>3</td><td>4</td><td>5</td> <td>ON OFF</td> </tr> <tr> <td>■</td><td>■</td><td>■</td><td>■</td><td>■</td> <td></td> </tr> </table> </td> </tr> <tr> <td>PLA-RP100EA</td> <td> <table border="1"> <tr> <td>1</td><td>2</td><td>3</td><td>4</td><td>5</td> <td>ON OFF</td> </tr> <tr> <td>■</td><td>■</td><td>■</td><td>■</td><td>■</td> <td></td> </tr> </table> </td> </tr> <tr> <td>PLA-RP125EA</td> <td> <table border="1"> <tr> <td>1</td><td>2</td><td>3</td><td>4</td><td>5</td> <td>ON OFF</td> </tr> <tr> <td>■</td><td>■</td><td>■</td><td>■</td><td>■</td> <td></td> </tr> </table> </td> </tr> <tr> <td>PLA-RP140EA</td> <td> <table border="1"> <tr> <td>1</td><td>2</td><td>3</td><td>4</td><td>5</td> <td>ON OFF</td> </tr> <tr> <td>■</td><td>■</td><td>■</td><td>■</td><td>■</td> <td></td> </tr> </table> </td> </tr> </tbody> </table>	MODELS	SETTING	PLA-RP35EA	<table border="1"> <tr> <td>1</td><td>2</td><td>3</td><td>4</td><td>5</td> <td>ON OFF</td> </tr> <tr> <td>■</td><td>■</td><td>■</td><td>■</td><td>■</td> <td></td> </tr> </table>	1	2	3	4	5	ON OFF	■	■	■	■	■		PLA-RP50EA	<table border="1"> <tr> <td>1</td><td>2</td><td>3</td><td>4</td><td>5</td> <td>ON OFF</td> </tr> <tr> <td>■</td><td>■</td><td>■</td><td>■</td><td>■</td> <td></td> </tr> </table>	1	2	3	4	5	ON OFF	■	■	■	■	■		PLA-RP60EA	<table border="1"> <tr> <td>1</td><td>2</td><td>3</td><td>4</td><td>5</td> <td>ON OFF</td> </tr> <tr> <td>■</td><td>■</td><td>■</td><td>■</td><td>■</td> <td></td> </tr> </table>	1	2	3	4	5	ON OFF	■	■	■	■	■		PLA-RP71EA	<table border="1"> <tr> <td>1</td><td>2</td><td>3</td><td>4</td><td>5</td> <td>ON OFF</td> </tr> <tr> <td>■</td><td>■</td><td>■</td><td>■</td><td>■</td> <td></td> </tr> </table>	1	2	3	4	5	ON OFF	■	■	■	■	■		PLA-RP100EA	<table border="1"> <tr> <td>1</td><td>2</td><td>3</td><td>4</td><td>5</td> <td>ON OFF</td> </tr> <tr> <td>■</td><td>■</td><td>■</td><td>■</td><td>■</td> <td></td> </tr> </table>	1	2	3	4	5	ON OFF	■	■	■	■	■		PLA-RP125EA	<table border="1"> <tr> <td>1</td><td>2</td><td>3</td><td>4</td><td>5</td> <td>ON OFF</td> </tr> <tr> <td>■</td><td>■</td><td>■</td><td>■</td><td>■</td> <td></td> </tr> </table>	1	2	3	4	5	ON OFF	■	■	■	■	■		PLA-RP140EA	<table border="1"> <tr> <td>1</td><td>2</td><td>3</td><td>4</td><td>5</td> <td>ON OFF</td> </tr> <tr> <td>■</td><td>■</td><td>■</td><td>■</td><td>■</td> <td></td> </tr> </table>	1	2	3	4	5	ON OFF	■	■	■	■	■		
MODELS	SETTING																																																																																																						
PLA-RP35EA	<table border="1"> <tr> <td>1</td><td>2</td><td>3</td><td>4</td><td>5</td> <td>ON OFF</td> </tr> <tr> <td>■</td><td>■</td><td>■</td><td>■</td><td>■</td> <td></td> </tr> </table>	1	2	3	4	5	ON OFF	■	■	■	■	■																																																																																											
1	2	3	4	5	ON OFF																																																																																																		
■	■	■	■	■																																																																																																			
PLA-RP50EA	<table border="1"> <tr> <td>1</td><td>2</td><td>3</td><td>4</td><td>5</td> <td>ON OFF</td> </tr> <tr> <td>■</td><td>■</td><td>■</td><td>■</td><td>■</td> <td></td> </tr> </table>	1	2	3	4	5	ON OFF	■	■	■	■	■																																																																																											
1	2	3	4	5	ON OFF																																																																																																		
■	■	■	■	■																																																																																																			
PLA-RP60EA	<table border="1"> <tr> <td>1</td><td>2</td><td>3</td><td>4</td><td>5</td> <td>ON OFF</td> </tr> <tr> <td>■</td><td>■</td><td>■</td><td>■</td><td>■</td> <td></td> </tr> </table>	1	2	3	4	5	ON OFF	■	■	■	■	■																																																																																											
1	2	3	4	5	ON OFF																																																																																																		
■	■	■	■	■																																																																																																			
PLA-RP71EA	<table border="1"> <tr> <td>1</td><td>2</td><td>3</td><td>4</td><td>5</td> <td>ON OFF</td> </tr> <tr> <td>■</td><td>■</td><td>■</td><td>■</td><td>■</td> <td></td> </tr> </table>	1	2	3	4	5	ON OFF	■	■	■	■	■																																																																																											
1	2	3	4	5	ON OFF																																																																																																		
■	■	■	■	■																																																																																																			
PLA-RP100EA	<table border="1"> <tr> <td>1</td><td>2</td><td>3</td><td>4</td><td>5</td> <td>ON OFF</td> </tr> <tr> <td>■</td><td>■</td><td>■</td><td>■</td><td>■</td> <td></td> </tr> </table>	1	2	3	4	5	ON OFF	■	■	■	■	■																																																																																											
1	2	3	4	5	ON OFF																																																																																																		
■	■	■	■	■																																																																																																			
PLA-RP125EA	<table border="1"> <tr> <td>1</td><td>2</td><td>3</td><td>4</td><td>5</td> <td>ON OFF</td> </tr> <tr> <td>■</td><td>■</td><td>■</td><td>■</td><td>■</td> <td></td> </tr> </table>	1	2	3	4	5	ON OFF	■	■	■	■	■																																																																																											
1	2	3	4	5	ON OFF																																																																																																		
■	■	■	■	■																																																																																																			
PLA-RP140EA	<table border="1"> <tr> <td>1</td><td>2</td><td>3</td><td>4</td><td>5</td> <td>ON OFF</td> </tr> <tr> <td>■</td><td>■</td><td>■</td><td>■</td><td>■</td> <td></td> </tr> </table>	1	2	3	4	5	ON OFF	■	■	■	■	■																																																																																											
1	2	3	4	5	ON OFF																																																																																																		
■	■	■	■	■																																																																																																			
J41 J42	Pair number setting with wireless remote controller	<table border="1"> <thead> <tr> <th rowspan="2">Wireless remote controller setting</th> <th colspan="2">Control PCB setting</th> </tr> <tr> <th>J41</th> <th>J42</th> </tr> </thead> <tbody> <tr> <td>0</td> <td>○</td> <td>○</td> </tr> <tr> <td>1</td> <td>×</td> <td>○</td> </tr> <tr> <td>2</td> <td>○</td> <td>×</td> </tr> <tr> <td>3 to 9</td> <td>×</td> <td>×</td> </tr> </tbody> </table>	Wireless remote controller setting	Control PCB setting		J41	J42	0	○	○	1	×	○	2	○	×	3 to 9	×	×	<p><Initial setting> Wireless remote controller: 0 Control PCB: ○ (for both J41 and J42) 4 pair number settings are supported. The pair number settings of the wireless remote controller and indoor control PCB (J41/J42) are given in the table on the left. ('×' in the table indicates the jumper wire is disconnected.)</p>																																																																																			
Wireless remote controller setting	Control PCB setting																																																																																																						
	J41	J42																																																																																																					
0	○	○																																																																																																					
1	×	○																																																																																																					
2	○	×																																																																																																					
3 to 9	×	×																																																																																																					

10-1. OPERATION (AUTO DESCENDING PANEL: PLP-6EAJ)

(1) Normal operation

① UP/DOWN

Air intake grille is raised/lowered by commands of UP and DOWN.

Air intake grille does not move under the state of no-load detection or obstacle detection.

Air intake grille automatically at the set lowering distance from the ceiling level.

② STOP

It stops in the cases below :

- When it reaches the set lowering distance from the ceiling level.

It automatically stops after a predetermined period of lowering.

- When it is stored in the panel.

The air intake grille is judged to be stored in the panel

when the storage detection switch is pressed for 5 seconds continuously.

- When receiving commands of STOP, DOWN while moving up or UP while moving down.

The STOP button is only available on the automatic filter elevation panel remote controller.

When the wired remote controller is used, there will be a slight delay in stopping due to transmission speed.

- When both string 1b and 2b are not loaded.

Only the string b in each UP/DOWN Machine has a tension detection switch.

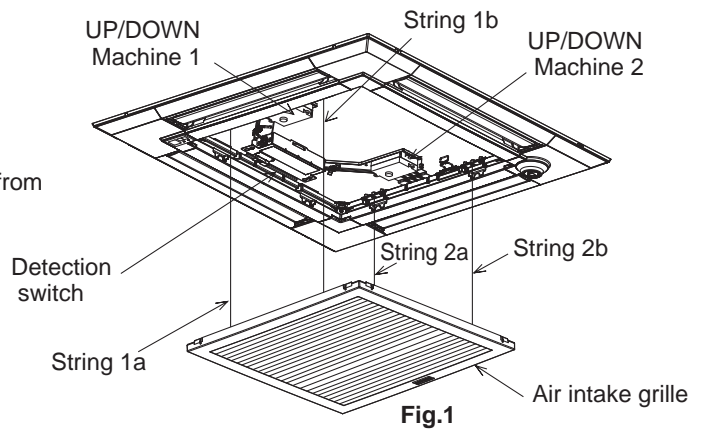

(2) Special operation

① Re-storage operation

Case : Obstruction of the raising grille before storage or malfunction of storage detection switch

Re-storage operation will be performed when the intake grille has been raised the set distance but the storage detection switch is not engaged.

In this case, the operation below will be repeated up to 4 times.

10 cm down → 30 cm up → ... → 10 cm down → 30 cm up

② No-load detection

Case : UP/DOWN commands with no grille suspended.

When both string 1b and string 2b are not loaded, the strings will not move.

③ Obstacle detection

Case : Making contact with something while lowering.

Should the loads on the string 1b and string 2b be removed due to the grille making contact with something while lowering,

the lowering operation will stop. The grille will then be raised 10 cm and stop again.

[EMERGENCY OPERATION]

1. If the wireless remote controller for ELEVATION PANEL is faulty or lost, operation will be possible using the emergency up/down switch at the wireless signal receiver or wired remote controller.

- For the operation using the emergency up/down switch at the wireless signal receiver, refer to SW1 and SW2 on the left [LEGEND].

2. When machine for ELEVATION PANEL breaks down, an intake grille is fixed for a while, and the operation of the unit can be done.

- Refer to installation manual with the grille for the details such as an installation method.

10-2. ELECTRICAL CIRCUIT (Controller board and wiring diagram (Panel))

10-2-1 DIP SW

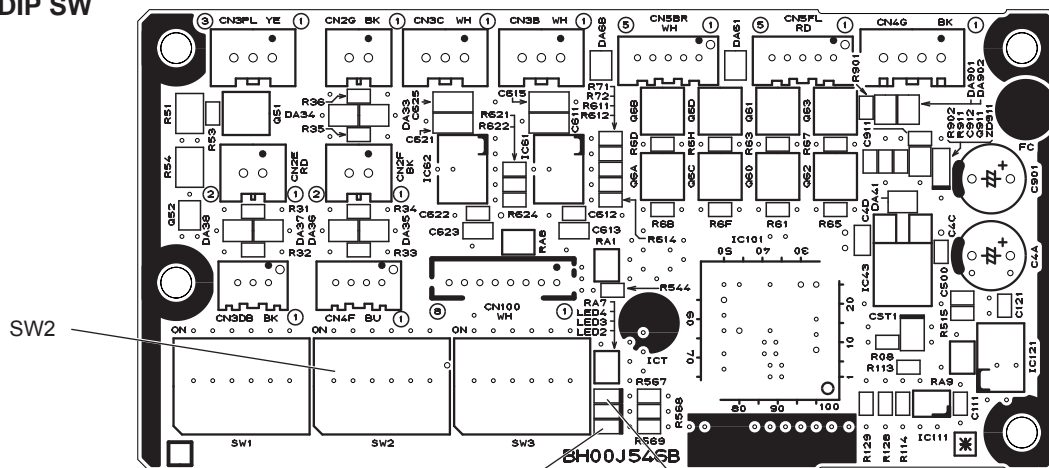

SYMBOL	NAME
U.B	ELEVATION PANEL CONTROLLER BOARD
LED2	LED ORANGE (INTAKE GRILLE CONDITION (See table *1))
LED4	LED GREEN (COMMUNICATION WITH INDOOR UNIT)
U.K 1	ELEVATION MACHINE
M	MOTOR (ELEVATION)
LS21	DETECTION SWITCH (STRING TENSION)
I.B	INDOOR UNIT CONTROLLER BOARD
W.B	PCB OF SIGNAL RECEIVER
BZ	BUZZER
RU	RECEIVING UNIT
LED1	LED GREEN (OPERATION INDICATION)
LED2	LED ORANGE (PREPARATION FOR HEATING)
SW1	EMERGENCY HEATING (INTAKE GRILLE DOWN (LONG PRESS FOR OVER 2SEC.)) (SHORT PRESS)
SW2	EMERGENCY COOLING (INTAKE GRILLE UP (LONG PRESS FOR OVER 2SEC.)) (SHORT PRESS)
LS1	DETECTION SWITCH (INTAKE GRILLE STORAGE)
R.B	WIRED REMOTE CONTROLLER

LOWERING DISTANCE	SET UP	LOWERING DISTANCE	SET UP
1.2m	ON OFF [■][■][■][■][■][■] 1 2 3 4 5 6	2.8m	ON OFF [■][■][■][■][■][■] 1 2 3 4 5 6
1.6m (Initial setting)	ON OFF [■][■][■][■][■][■] 1 2 3 4 5 6	3.2m	ON OFF [■][■][■][■][■][■] 1 2 3 4 5 6
2.0m	ON OFF [■][■][■][■][■][■] 1 2 3 4 5 6	3.6m	ON OFF [■][■][■][■][■][■] 1 2 3 4 5 6
2.4m	ON OFF [■][■][■][■][■][■] 1 2 3 4 5 6	4.0m	ON OFF [■][■][■][■][■][■] 1 2 3 4 5 6

Note: The actual lowering distance might be different from the distance in the table 2 since it can also be set using the wired remote controller.

LED2 LED4

[EMERGENCY OPERATION]

- If the wireless remote controller for ELEVATION PANEL is faulty or lost, operation will be possible using the emergency up/down switch at the wireless signal receiver or wired remote controller.
 - For the operation using the emergency up/down switch at the wireless signal receiver, refer to SW1 and SW2 on the left [LEGEND].
- When machine for ELEVATION PANEL breaks down, an intake grille is fixed for a while, and the operation of the unit can be done.
 - Refer to installation manual with the grille for the details such as an installation method.

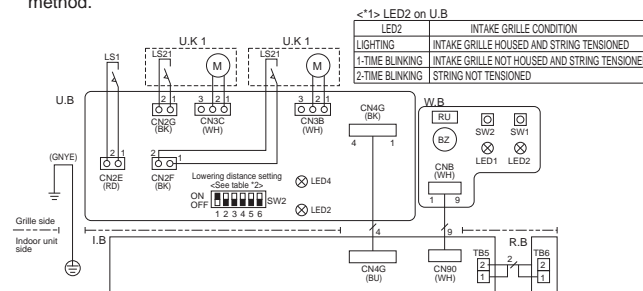

[Note]

- Symbols used in wiring diagram above are, [] : Connector, [] : Terminal (block).
- The black square (■) indicates a switch position.

10-2-2. Check point of trouble

<LED 2 Orange display>

- Turn OFF : No power supply
- Blink : Storage detection switch ON (short)
- One blink : Storage detection switch OFF (open)
- Two blinks : Tension detection switch OFF (open)

<LED 4 Green display>

- Blink : Connecting

<controller board>

Check item	Check point	Normal	Remarks
Up/down controller P.C. board supply voltage	CN4A (between 1-2)	11-14 V AC	—
Up/down machine supply voltage	CN3B (between 1-2) CN3C (between 1-2)	10-13.5 V DC	Check when instructing up/down with LED blinking once.

<Up/down machine>

Check item	Check point	Normal	Check contents
Storage detection switch	CN2E	open or short	Check if it is short when pressing push switch.
Tension detection switch	CN2F, CN2G	open or short	Check if it is short when string b is tensioned.
Motor	CN3B, CN3C	5-20 Ω	Check if it is not open or short.
Entwining strings	Pull string	Retention: about 2 kgf	Check if string is drawn out by pulling with 4 kgf.

10-3. TROUBLESHOOTING

- Check the following points.

Problem	Possible Reason	Corrective Action
Intake grille does not function with operation of the remote controller.	Air-conditioner is running.	Stop running the air-conditioner and try again.
	Power failure.	After recovering from power failure, try again.
	Batteries are not inserted into the wireless remote controller. Or battery power is running low.	Install or replace the battery.
	There is something on the intake grille. Or something is stuck in the intake grille.	Remove the objects or obstacles from the intake grille. Or, remove the stuck object.
Intake grille cannot be placed in the correct position.	There is something on the intake grille.	Remove the objects or obstacles from the intake grille.
	Filter is not properly installed.	Lower the intake grille again and check whether the filter is installed in the correct position.
	Intake grille is not hung with all 4 hooks.	Lower the intake grille again and hang the hook on the intake grille.
Intake grille stops lowering in mid flow. (Intake grille would not lower any further.)	Because the intake grille has finished lowering to the auto-stop position.	This is normal. Note: If you want to change the setting for the lowering distance, contact your dealer.
Noises are made during up/down operation. (While intake grille is moving up/down.)	This is the noise made when the string is wound and unwound.	This is normal.
Noises are made while placing the intake grille in.	This is the operational noise for placing the intake grille in securely.	
Intake grille repeats rising and lowering several times while being placed in the correct position.	This is the operation for placing the intake grille in securely.	
Intake grille leans toward one side during the up/down operation.	The speeds of winding each string is slightly different.	

10-4. ROTATION FUNCTION (AND BACK-UP FUNCTION, 2ND STAGE CUT-IN FUNCTION)

10-4-1. Operation

(1) Rotation function (and Back-up function)

• Outline of functions

- Main and sub unit operate alternately according to the interval of rotation setting.
Note: Main and sub unit should be set by refrigerant address. (Outdoor DIP switch setting)
Refrigerant address "00" → Main unit
Refrigerant address "01" → Sub unit
- When error occurs to one unit, another unit will start operation. (Back-up function)

• System constraint

- This function is available only by the grouping control system (INDOOR UNIT : OUTDOOR UNIT=1:1) of 2 refrigerant groups. (Refer to Fig. 1)
- Main indoor unit should be connected for wired remote controller and the transmission line (TB5) for main and sub unit should also be connected. (Refer to Fig. 1)
(This function cannot be set by wireless remote controller.)
- Set refrigerant address of each unit. (Dip switch on the outdoor unit ... Refrigerant address 00/01)

Operation pattern

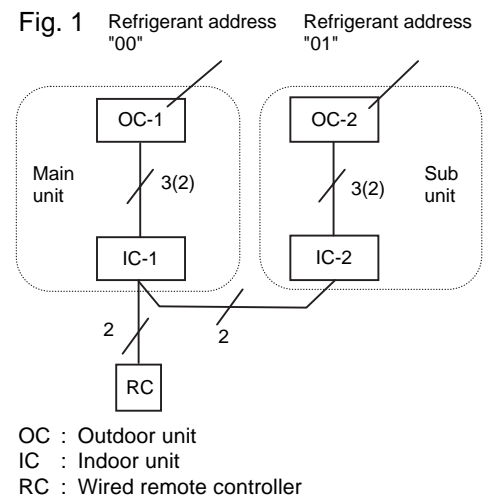
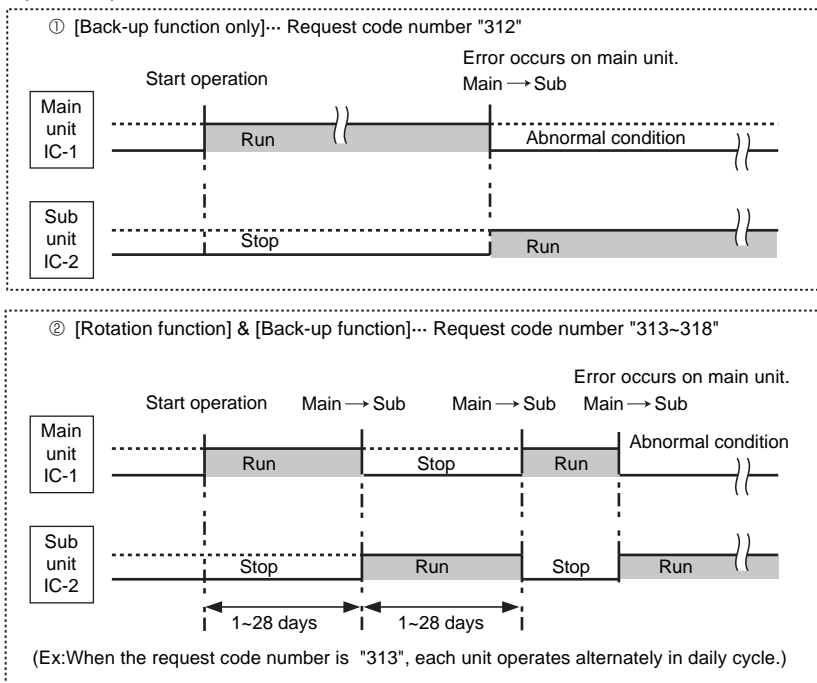

Note:

- When the unit is restarted to operate after turning off the power or OFF operation, the unit which was operating will start operation.
- To operate the main unit, refer to "10-4-2. How to set rotation function (Back-up function, 2nd stage cut-in function)" and set the request code No. which is not the same as the current one, then set again the former request code No.

(2) 2nd stage cut-in function

Outline of functions

- When the 1st unit cannot supply with sufficient capacity for exceptionally high-demand conditions and the actual room temperature reaches set point (*), the 2nd unit starts operation in conjunction with the 1st unit.
- Once the actual room temperature goes down to 4°C below set point (*), the 2nd unit stops operation automatically.
(* set point = set temperature by R/C (remote controller) + 4, 6, 8°C (selectable))
- Number of operating units is determined according to the room temperature and set point.
- When room temperature reaches higher than set point, standby unit starts. (2 units operation)
- When room temperature falls below set point -4°C, standby unit stops. (1 unit operation)

• **System constraint**

- This function is available only in cooling mode.

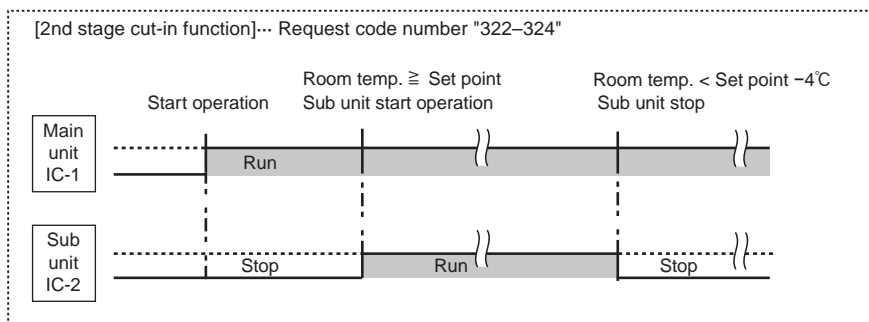
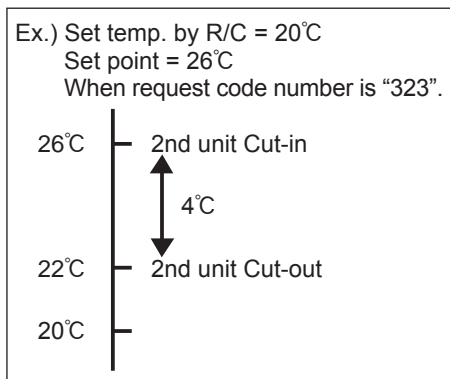

10-4-2. How to set rotation function (Back-up function, 2nd stage cut-in function)

You can set these functions by wired remote controller. (Maintenance monitor)

NOTICE

Both main and sub unit should be set in same setting.
Every time replacing indoor controller board for servicing, the function should be set again.

(1) Request Code List

Rotation setting

Setting No. (Request code)	Setting contents	Initial setting
No.1 (310)	Monitoring the request code of current setting	
No.2 (311)	Rotation and Back-up OFF (Normal group control operation)	☉
No.3 (312)	Back-up function only	
No.4 (313)	Rotation ON (Alternating interval = 1day) and back-up function	
No.5 (314)	Rotation ON (Alternating interval = 3days) and back-up function	
No.6 (315)	Rotation ON (Alternating interval = 5days) and back-up function	
No.7 (316)	Rotation ON (Alternating interval = 7days) and back-up function	
No.8 (317)	Rotation ON (Alternating interval = 14days) and back-up function	
No.9 (318)	Rotation ON (Alternating interval = 28days) and back-up function	

2nd unit cut-in setting

Setting No. (Request code)	Setting contents	Initial setting
No.1 (320)	Monitoring the request code of current setting	
No.2 (321)	Cut-in function OFF	☉
No.3 (322)	Cut-in function ON(Set point = Set temp.+ 4°C (7.2°F))	
No.4 (323)	Cut-in function ON(Set point = Set temp.+ 6°C (10.8°F))	
No.5 (324)	Cut-in function ON(Set point = Set temp.+ 8°C (14.4°F))	

(2) Rotation and back up operation

PAR-32MAA

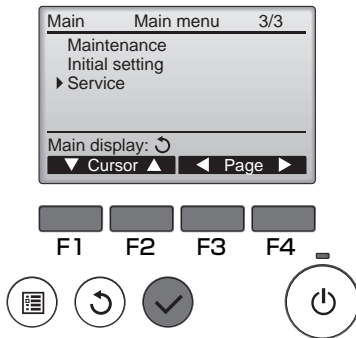

① Press the button.

② Select "Service" with the [Cursor] buttons (and) or the [Page] buttons (and), and press the button.

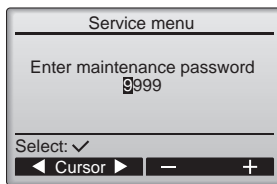

③ Enter the current maintenance password (4 numerical digits).
• Move cursor to the digit you want to change with the or button.
• Set each number (0 through 9) with the or button.
(Note: The initial maintenance password is "9999".)

④ Then, press the button.

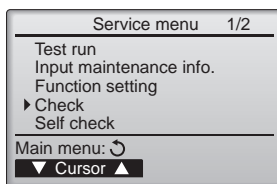

⑤ Select "Check" with the or button, and press the button.

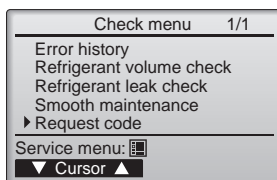

⑥ Select "Request code" with the or button, and press the button.

⑦ Set the Refrigerant address and Request code.
• Select the item to be changed with the or button.
• Select the required setting with the or button.

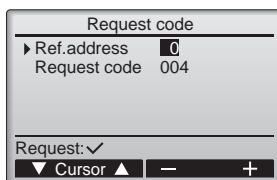

⑧ Press the or button to set the Refrigerant address "0".

⑨ Press the or button to set the desired request code No.
• Rotation & Back up operation: Enter one request code from 311–318.
• 2nd stage cut-in operation: Enter one request code from 321–324.

⑩ Press the button. Data will be collected and displayed.

⑪ Press the or button to set the Refrigerant address "1".
Set above ⑨–⑩.

⑫ To return to the Main menu, press the button.

PLA-RP35EA.UK
PLA-RP71EA.UK

PLA-RP50EA.UK
PLA-RP100EA.UK

PLA-RP60EA.UK
PLA-RP125EA.UK

PLA-RP140EA.UK

Be careful when removing heavy parts.

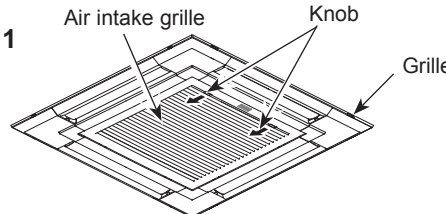
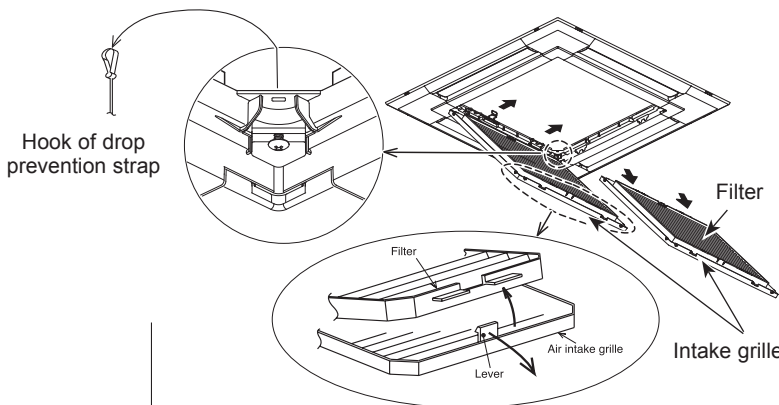
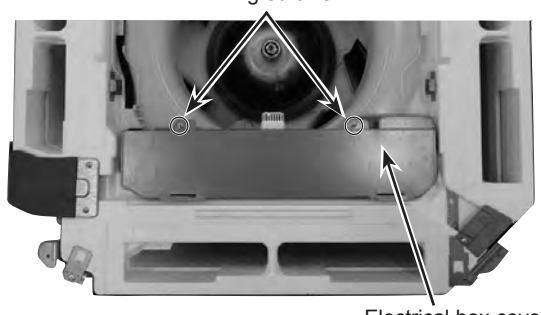
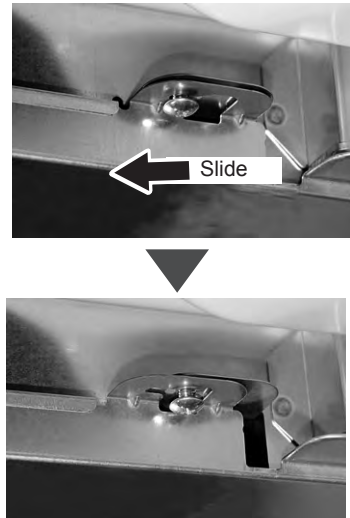
OPERATING PROCEDURE	PHOTOS & ILLUSTRATIONS
<p>1. Removing the filter</p> <p>(1) Slide the knob of air intake grille toward the arrow to open the air intake grille. (See Figure 1.)</p> <p>(2) Pull down the lever of the air intake grille to remove the filter. (See Figure 2.)</p>	<p>Figure 1</p> 
<p>2. Removing the air intake grille</p> <p>(1) Slide the knob of air intake grille toward the arrow to open the air intake grille. (See Figure 1.)</p> <p>(2) Remove the hook of drop prevention strap from the panel.</p> <p>(3) Remove the air intake grille.</p>	<p>Figure 2</p> 
<p>3. Removing the electrical box cover</p> <p>(1) Remove the air intake grille and the filter. (Refer to 2.)</p> <p>(2) Loosen the 2 electrical box cover fixing screws (M4×10) approximately 2 to 3 mm. (See Photo 1.)</p> <p>(3) Slide the electrical box cover toward the arrow to remove. (See Photo 2.)</p>	<p>Photo 1</p>  <p>Photo 2</p> 

OPERATING PROCEDURE

4. Removing the room temperature thermistor (TH1)

- (1) Remove the electrical box cover. (See Photo 1 and 2.)
- (2) Disconnect the connector CN20 (Red) from the indoor controller board.
- (3) Remove the room temperature thermistor with its holder. (See Photo 3.)

PHOTOS

Photo 3

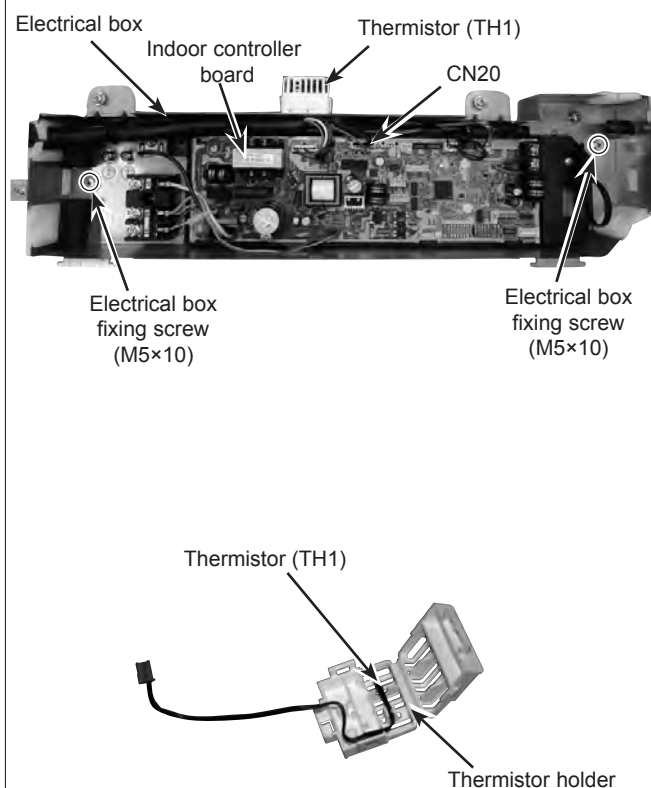

5. Removing the indoor controller board (I.B)

- (1) Remove the electrical box cover. (See Photo 1 and 2.)
- (2) Disconnect the connectors:
 - CNMF (White) for fan motor
 - CNV (White) for vane motor
 - CN5Y (White) for motor for i-see Sensor (Option)
 - CN4Z (White) for sensor for i-see Sensor (Option)
 - CN90 (White) for signal receiver (Option)
 - CNP (White) for drain pump
 - CN4F (White) for float switch
 - CN44 (White) for thermistor (TH2/TH5)
 - CN01 (Black) for Indoor/Outdoor connecting line
 - CN3C (Blue) for Indoor/Outdoor transmission

Disconnect the connectors for optional parts, if any.

- (3) For the unit controlled with the wireless remote controller, disconnect the lead wire connected to TB5 on the indoor controller board.
TB5: Remote controller transmission connecting wire
- (4) Remove the indoor controller board (3 holders/4 Hooks). (See Photo 4.)

Photo 4

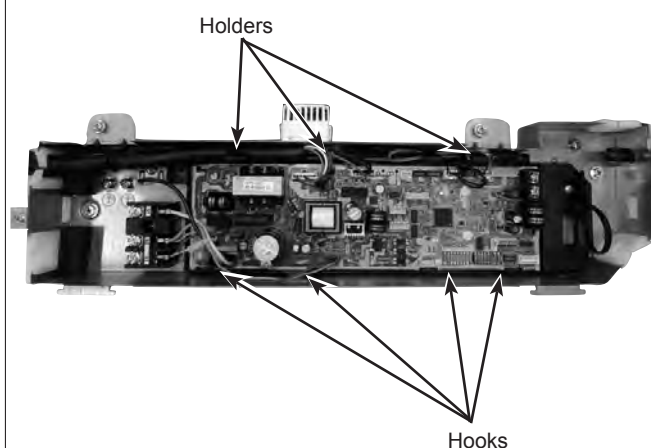

Be careful when removing heavy parts.

OPERATING PROCEDURE

6. Removing the electrical box

- (1) Remove the electrical box cover (See Photo 1 and 2.) and the connectors (Refer to 5.).
- (2) Remove the electrical box fixing screws (M5×10: 2 screw). (See Photo 3.)

<Electrical parts in the electrical box>

- Terminal block for earth and reactor
- Indoor controller board
- Thermistor(TH)

- (3) Remove the electrical box (2 hooks).

7. Removing the turbo fan

- (1) Remove the electrical box. (See Photo 3 and refer to 6.)
- (2) Remove the bell mouth (tapping screw 4×10: 2 screws). (See Photo 5.)
- (3) Remove the nut and washer (1 nut). (See Photo 6 and 7.)
- (4) Remove the turbo fan.

Photo 7



Turn this way to tighten. Turn this way to loosen.
(The same directions as the fan rotation.)

Rubber mount

Note: When re-attaching the motor mount, make sure that the thicker end faces the motor shaft.

8. Removing the fan motor (MF)

- (1) Remove the turbo fan. (See Photo 6 and refer to 7.)
- (2) Remove the lead cover (tapping screw 4×10: 2 screws). (See Photo 9.)
- (3) Loosen the 2 clamps.
- (4) Remove the 3 washer nuts (M5) .
- (5) Remove the fan motor.
- (6) Remove the 3 rubber mounts.

Figure 3
Cross section diagram

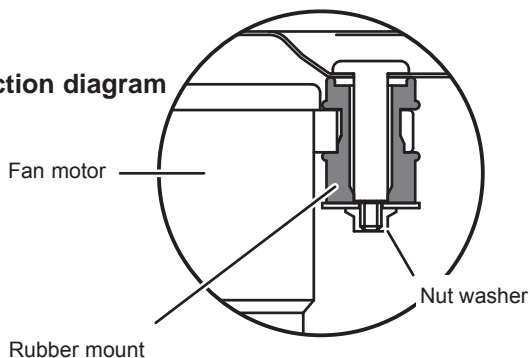

Note: When re-attaching the motor mount, make sure that the thicker end faces the motor shaft.

PHOTOS & ILLUSTRATIONS

Photo 5

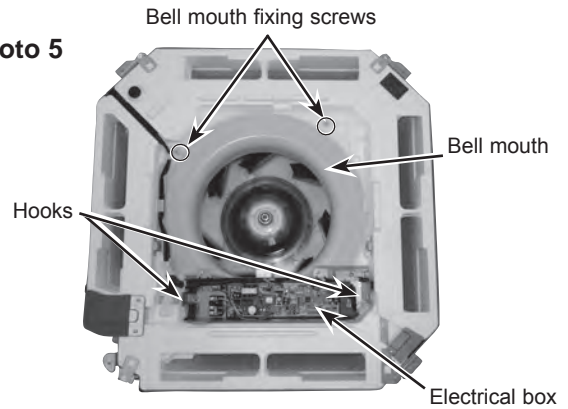

Photo 6

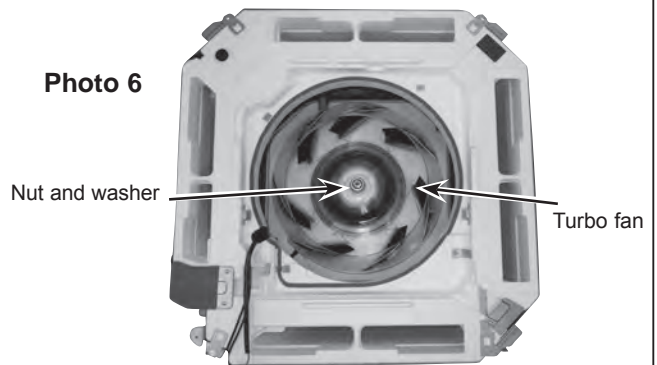
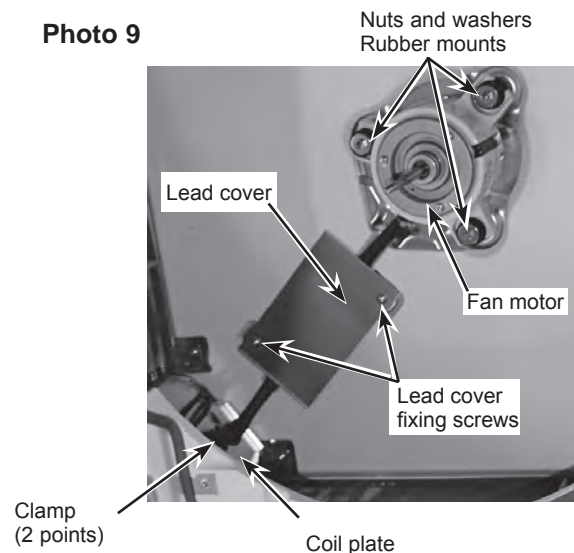

Photo 8



Photo 9



OPERATING PROCEDURE

9. Removing the panel

- (1) Remove the electrical box fixing cover. (See Photo 1.)
- (2) Disconnect the connector for vane motor (CNV: White). (Refer to 5.)
- (3) Loosen the 4 corner panel fixing screws (tapping screw 4×16). (See Figure 4.)
- (4) Slide the corner panel to the direction of the arrow ①, and remove the corner panel. (See Figure 4.)
- (5) Remove the 4 installation screws (M5×28). (See Photo 10.)
- (6) Release the 2 temporary hanging hooks to remove the grille. (See Photo 11.)

PHOTOS & ILLUSTRATIONS

Figure 4

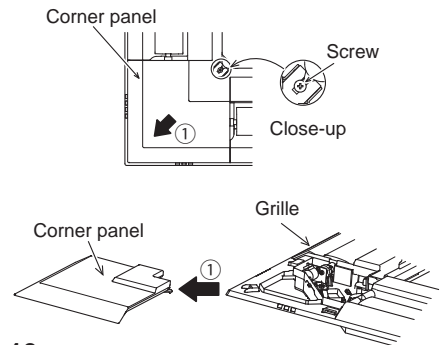

Photo 10

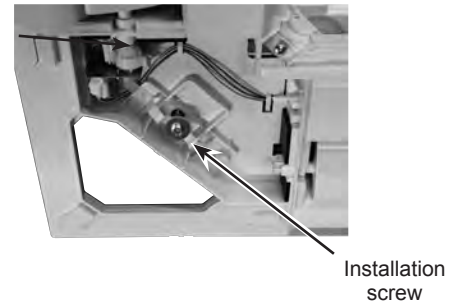

Photo 11



10. Removing the drain pan

- (1) Remove the electrical box. (See photo 3 and refer to 6.)
- (2) Remove the bell mouth (tapping screw 4×10 : 2 screws). (See Photo 5.)
- (3) Remove the drain pan (screw M5×10: 4 screws).

Photo 12

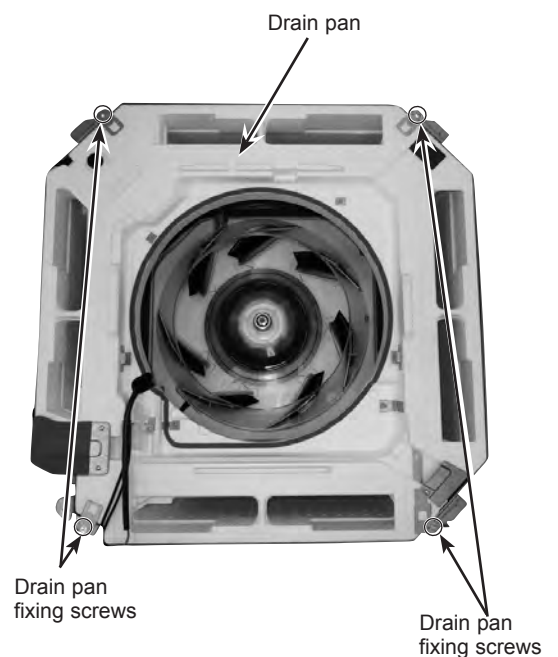

OPERATING PROCEDURE

11. Removing the pipe temperature/liquid thermistor (TH2) and condenser/evaporator temperature thermistor (TH5)

- (1) Remove the drain pan (Refer to 10.) and loosen the 2 clamps of the coil plate. (See Photo 9.)
- (2) Remove the coil plate (tapping screw 4×10: 2 screws).
- (3) Disconnect the pipe temperature/liquid thermistor (TH2) and condenser/evaporator temperature thermistor (TH5) from the holder.

PHOTOS & ILLUSTRATIONS

Photo 13



Pipe temperature/liquid thermistor (TH2)

Condenser/evaporator temperature thermistor (TH5)

12. Removing the drain pump (DP)

- (1) Remove the drain pan. (Refer to 10.)
- (2) Cut the hose band and remove the hose.
- (3) Loosen the clamp of the drain pump.
- (4) Remove the drain pump (tapping screw 4×10: 2 screws/2 hooks).
- (5) Cut the drain pump base and lead wire fixing band. (See Figure 5.)
- (6) Remove the lead wire of the drain pump from the clamp of the drain pump base. (See Figure 5.)
- (7) Remove the drain pump (tapping screw: 3 screws). (See Figure 6.)

Photo 14

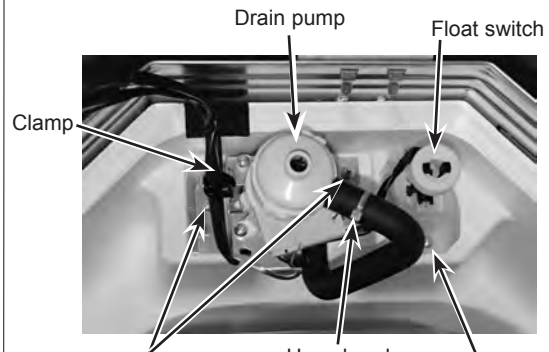

Drain pump base fixing screws

Hose band

Float switch fixing screw

Figure 6

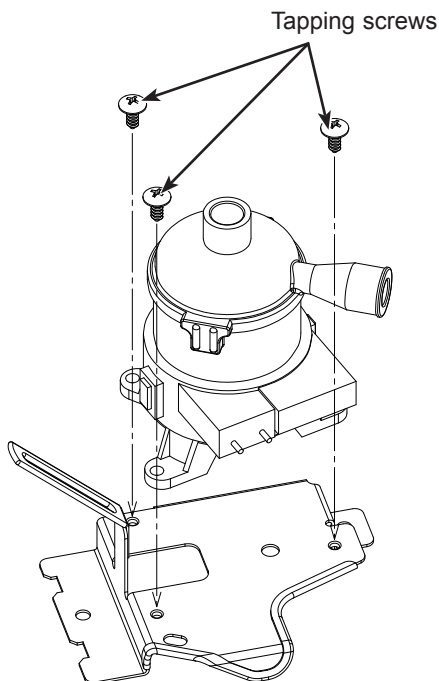
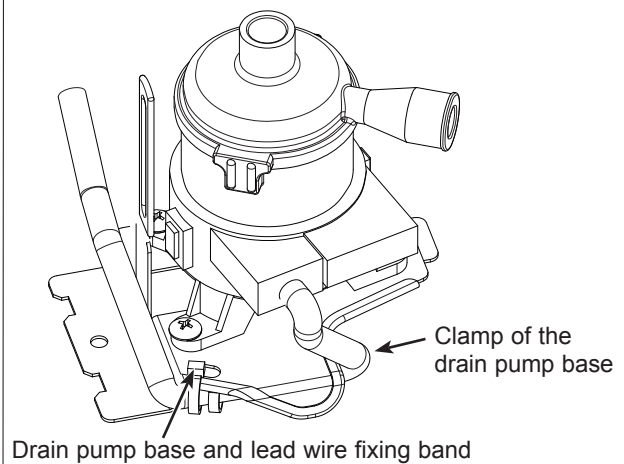

Figure 5



OPERATING PROCEDURE

13. Removing the float switch (FS)

- (1) Remove the drain pan. (Refer to 10.)
- (2) Loosen the clamp of the drain pump. (See Photo 14.)
- (3) Remove the float switch (tapping screw 4×10: 1 screw/1 hook). (See Photo 14.)
- (4) Remove the float switch base and the lead wire fixing band. (See Photo 15.)
- (5) Remove the lead wire from the U shaped portion of the float switch base. (See Photo 15.)
- (6) Slide the float switch towards the arrow to remove from the float switch base.

PHOTOS

Photo 15

Do not hold this floating part when lifting; Doing so will cause malfunction.

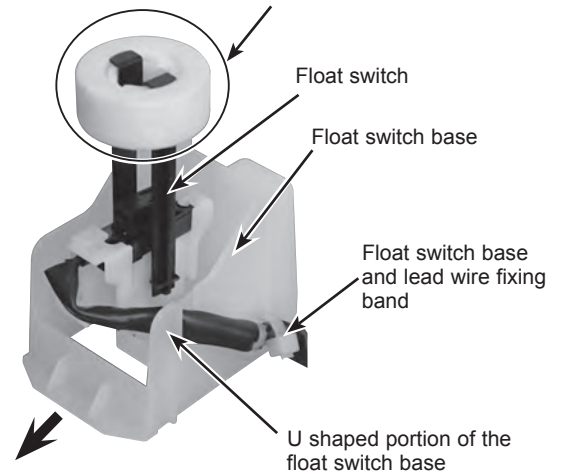

14. Removing the heat exchanger

- (1) Remove the drain pan. (Refer to 10.)
- (2) Remove the piping cover (tapping screw 4×10: 3 screws).
- (3) Remove the coil plate (tapping screw 4×10: 2 screws).
- (4) Remove the heat exchanger fixing screws (tapping screw 4×10: 2 screws).
- (5) Remove the coil support (tapping screw 4×10: 1 screw each)
 - RP35-71 Coil support 1 part (See photo16.)
 - RP100-140 Coil support 3 part (See photo17.)
- (6) Remove the heat exchanger.

Photo 16

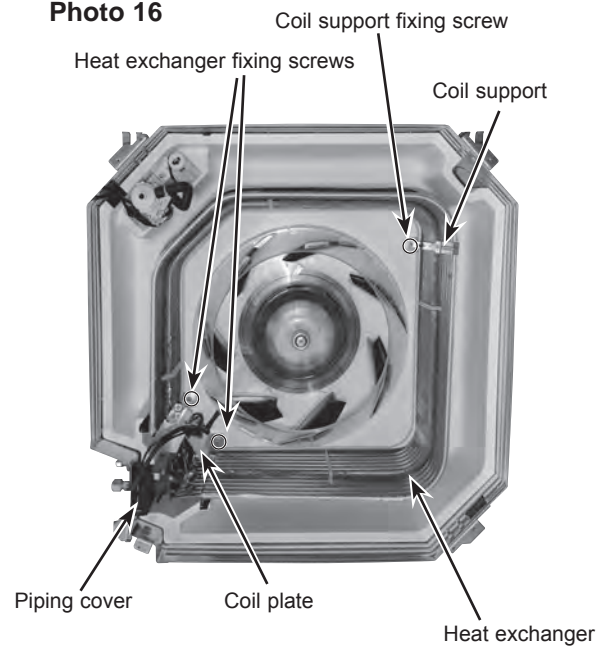
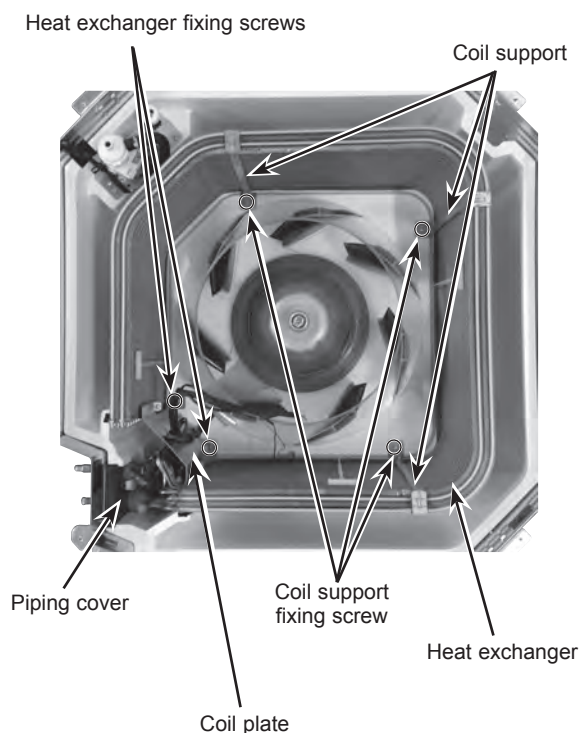

Photo 17



Mr. SLIM

mitsubishi electric corporation
HEAD OFFICE : TOKYO BUILDING, 2-7-3, MARUNOUCHI, CHIYODA-KU, TOKYO 100-8310, JAPAN
