

Air-Conditioners

Кондиционеры

PLA-ZP-EA Series

PLA-RP-EA Series



INSTALLATION MANUAL

For safe and correct use, read this manual and the outdoor unit installation manual thoroughly before installing the air-conditioner unit.

FOR INSTALLER

INSTALLATIONSHANDBUCH

Aus Sicherheitsgründen und zur richtigen Anwendung vor Installation der Klimaanlage die vorliegende Bedienungsanleitung und das Installationshandbuch gründlich durchlesen.

FÜR INSTALLATEURE

MANUEL D'INSTALLATION

Avant d'installer le climatiseur, lire attentivement ce manuel, ainsi que le manuel d'installation de l'appareil extérieur pour une utilisation sûre et correcte.

POUR L'INSTALLATEUR

INSTALLATIEHANDLEIDING

Lees deze handleiding en de installatiehandleiding van het buitenapparaat zorgvuldig door voordat u met het installeren van de airconditioner begint.

VOOR DE INSTALLATEUR

MANUAL DE INSTALACIÓN

Para un uso seguro y correcto, lea detalladamente este manual de instalación antes de montar la unidad de aire acondicionado.

PARA EL INSTALADOR

MANUALE DI INSTALLAZIONE

Per un uso sicuro e corretto, prima di installare il condizionatore d'aria leggere attentamente il presente manuale ed il manuale d'installazione dell'unità esterna.

PER L'INSTALLATORE

ΕΓΧΕΙΡΙΔΙΟ ΟΔΗΓΙΩΝ ΕΓΚΑΤΑΣΤΑΣΗΣ

Για σωστή και ασφαλή χρήση, διαβάστε προσεκτικά αυτό το εγχειρίδιο, καθώς και το εγχειρίδιο εγκατάστασης της εξωτερικής μονάδας, πριν από την εγκατάσταση της μονάδας κλιματιστικού.

ΓΙΑ ΑΥΤΟΝ ΠΟΥ ΚΑΝΕΙ ΤΗΝ ΕΓΚΑΤΑΣΤΑΣΗ

MANUAL DE INSTALAÇÃO

Para uma utilização segura e correcta, leia atentamente este manual e o manual de instalação da unidade exterior antes de instalar o aparelho de ar condicionado.

PARA O INSTALADOR

INSTALLATIONSMANUAL

Læs af sikkerhedshensyn denne manual samt manualen til installation af udendørsenheden grundigt, før du installerer klimaanlægget.

TIL INSTALLATØREN

INSTALLATIONSMANUAL

Läs bruksanvisningen och utomhusenhetens installationshandbok noga innan luftkonditioneringen installeras så att den används på ett säkert och korrekt sätt.

FÖR INSTALLATÖREN

MONTAJ ELKİTABI

Emniyetli ve doğru kullanım için, klima cihazını monte etmeden önce bu kılavuzu ve dış ünite montaj kılavuzunu tamamiyle okuyun.

MONTÖR İÇİN

РУКОВОДСТВО ПО УСТАНОВКЕ

Для обеспечения безопасной и надлежащей эксплуатации внимательно прочтите данное руководство и руководство по установке наружного прибора перед установкой кондиционера.

ДЛЯ УСТАНОВИТЕЛЯ

INSTALLASJONSHÅNDBOK

For sikkert og riktig bruk av klimaanlegget, vennligst les nøye gjennom denne bruksanvisningen før det installeres.

FOR MONTØR

INSTRUKCJA MONTAŻU

Aby zapewnić bezpieczne i prawidłowe korzystanie z klimatyzatora, przed montażem należy uważnie przeczytać niniejszą instrukcję montażu.

DLA INSTALATORA

English

Deutsch

Français

Nederlands

Español

Italiano

Ελληνικά

Português

Dansk

Svenska

Türkçe

Русский

Norsk

Polski

Contents

1. Safety precautions.....	2	6. Electrical work	7
2. Installation location.....	3	7. Test run.....	13
3. Installing the indoor unit	3	8. System control	16
4. Installing the refrigerant piping	5	9. Installing the grille.....	17
5. Drainage piping work.....	6	10. Easy maintenance function.....	19

Note:

The phrase "Wired remote controller" in this installation manual refers only to the PAR-32MAA.

If you need any information for the other remote controller, please refer to either the installation manual or initial setting manual which are included in these boxes.

1. Safety precautions

- ▶ Before installing the unit, make sure you read all the "Safety precautions".
- ▶ Please report to your supply authority or obtain their consent before connecting this equipment to the power supply system.

Warning:

Describes precautions that must be observed to prevent danger of injury or death to the user.

Caution:

Describes precautions that must be observed to prevent damage to the unit.

Warning:

- Ask a dealer or an authorized technician to install the unit.
- The user should never attempt to repair the unit or transfer it to another location.
- For installation work, follow the instructions in the Installation Manual and use tools and pipe components specifically made for use with refrigerant specified in the outdoor unit installation manual.
- The unit must be installed according to the instructions in order to minimize the risk of damage from earthquakes, typhoons, or strong winds. An incorrectly installed unit may fall down and cause damage or injuries.
- The unit must be securely installed on a structure that can sustain its weight.
- If the air conditioner is installed in a small room, measures must be taken to prevent the refrigerant concentration in the room from exceeding the safety limit in the event of refrigerant leakage. Should the refrigerant leak and cause the concentration limit to be exceeded, hazards due to lack of oxygen in the room may result.
- Ventilate the room if refrigerant leaks during operation. If refrigerant comes into contact with a flame, poisonous gases will be released.
- All electric work must be performed by a qualified technician according to local regulations and the instructions given in this manual.
- Use only specified cables for wiring. The wiring connections must be made securely with no tension applied on the terminal connections. Also, never splice the cables for wiring (unless otherwise indicated in this document). Failure to observe these instructions may result in overheating or a fire.

After installation work has been completed, explain the "Safety Precautions," use, and maintenance of the unit to the customer according to the information in the Operation Manual and perform the test run to ensure normal operation. Both the Installation Manual and Operation Manual must be given to the user for keeping. These manuals must be passed on to subsequent users.

⚡: Indicates a part which must be grounded.

Warning:

Carefully read the labels affixed to the main unit.

- The appliance shall be installed in accordance with national wiring regulations.
- This appliance is not intended for use by persons (including children) with reduced physical, sensory or mental capabilities, or lack of experience and knowledge, unless they have been given supervision or instruction concerning use of the appliance by a person responsible for their safety.
- Children should be supervised to ensure that they do not play with the appliance.
- The terminal block cover panel of the unit must be firmly attached.
- If the supply cord is damaged, it must be replaced by the manufacturer, its service agent or similarly qualified persons in order to avoid a hazard.
- Use only accessories authorized by Mitsubishi Electric and ask a dealer or an authorized technician to install them.
- After installation has been completed, check for refrigerant leaks. If refrigerant leaks into the room and comes into contact with the flame of a heater or portable cooking range, poisonous gases will be released.
- When installing or relocating, or servicing the air conditioner, use only the specified refrigerant (R410A) to charge the refrigerant lines. Do not mix it with any other refrigerant and do not allow air to remain in the lines. If air is mixed with the refrigerant, then it can be the cause of abnormal high pressure in the refrigerant line, and may result in an explosion and other hazards. The use of any refrigerant other than that specified for the system will cause mechanical failure or system malfunction or unit breakdown. In the worst case, this could lead to a serious impediment to securing product safety.

1.1. Before installation (Environment)

Caution:

- Do not use the unit in an unusual environment. If the air conditioner is installed in areas exposed to steam, volatile oil (including machine oil), or sulfuric gas, areas exposed to high salt content such as the seaside, the performance can be significantly reduced and the internal parts can be damaged.
- Do not install the unit where combustible gases may leak, be produced, flow, or accumulate. If combustible gas accumulates around the unit, fire or explosion may result.
- Do not keep food, plants, caged pets, artwork, or precision instruments in the direct airflow of the indoor unit or too close to the unit, as these items can be damaged by temperature changes or dripping water.

- When the room humidity exceeds 80% or when the drainpipe is clogged, water may drip from the indoor unit. Do not install the indoor unit where such dripping can cause damage.
- When installing the unit in a hospital or communications office, be prepared for noise and electronic interference. Inverters, home appliances, high-frequency medical equipment, and radio communications equipment can cause the air conditioner to malfunction or breakdown. The air conditioner may also affect medical equipment, disturbing medical care, and communications equipment, harming the screen display quality.

1.2. Before installation or relocation

Caution:

- Be extremely careful when transporting the units. Two or more persons are needed to handle the unit, as it weighs 20 kg or more. Do not grasp the packaging bands. Wear protective gloves as you can injure your hands on the fins or other parts.
- Be sure to safely dispose of the packaging materials. Packaging materials, such as nails and other metal or wooden parts may cause stabs or other injuries.
- Thermal insulation of the refrigerant pipe is necessary to prevent condensation. If the refrigerant pipe is not properly insulated, condensation will be formed.
- Place thermal insulation on the pipes to prevent condensation. If the drainpipe is installed incorrectly, water leakage and damage to the ceiling, floor, furniture, or other possessions may result.

- Do not clean the air conditioner unit with water. Electric shock may result.
- Tighten all flare nuts to specification using a torque wrench. If tightened too much, the flare nut can break after an extended period.
- If the unit is run for long hours when the air above the ceiling is at high temperature/high humidity (dew point above 26 °C), dew condensation may be produced in the indoor unit or the ceiling materials. When operating the units in this condition, add insulation material (10-20 mm) to the entire surface of the unit and ceiling materials to avoid dew condensation.

1.3. Before electric work

Caution:

- Be sure to install circuit breakers. If not installed, electric shock may result.
- For the power lines, use standard cables of sufficient capacity. Otherwise, a short circuit, overheating, or fire may result.
- When installing the power lines, do not apply tension to the cables.

- Be sure to ground the unit. If the unit is not properly grounded, electric shock may result.
- Use circuit breakers (ground fault interrupter, isolating switch (+B fuse), and molded case circuit breaker) with the specified capacity. If the circuit breaker capacity is larger than the specified capacity, breakdown or fire may result.

1.4. Before starting the test run

Caution:

- Turn on the main power switch more than 12 hours before starting operation. Starting operation just after turning on the power switch can severely damage the internal parts.
- Before starting operation, check that all panels, guards and other protective parts are correctly installed. Rotating, hot, or high voltage parts can cause injuries.

- Do not operate the air conditioner without the air filter set in place. If the air filter is not installed, dust may accumulate and breakdown may result.
- Do not touch any switch with wet hands. Electric shock may result.
- Do not touch the refrigerant pipes with bare hands during operation.
- After stopping operation, be sure to wait at least five minutes before turning off the main power switch. Otherwise, water leakage or breakdown may result.

2. Installation location

Refer to the outdoor unit installation manual.

3. Installing the indoor unit

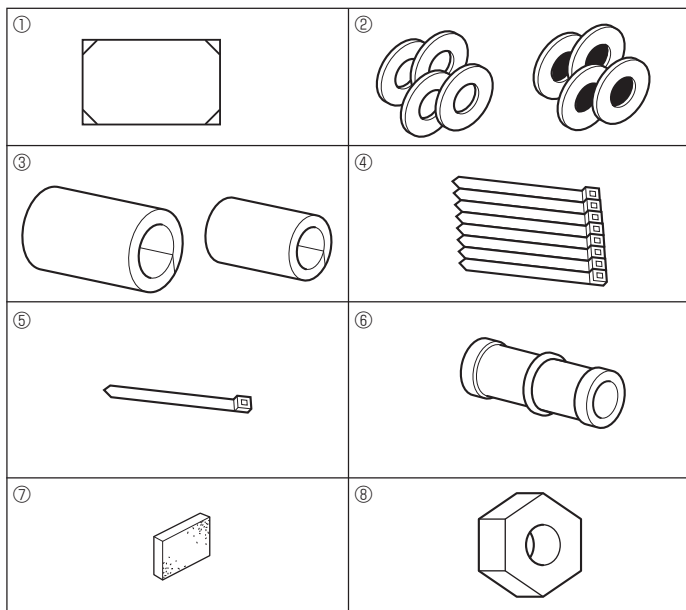

Fig. 3-1

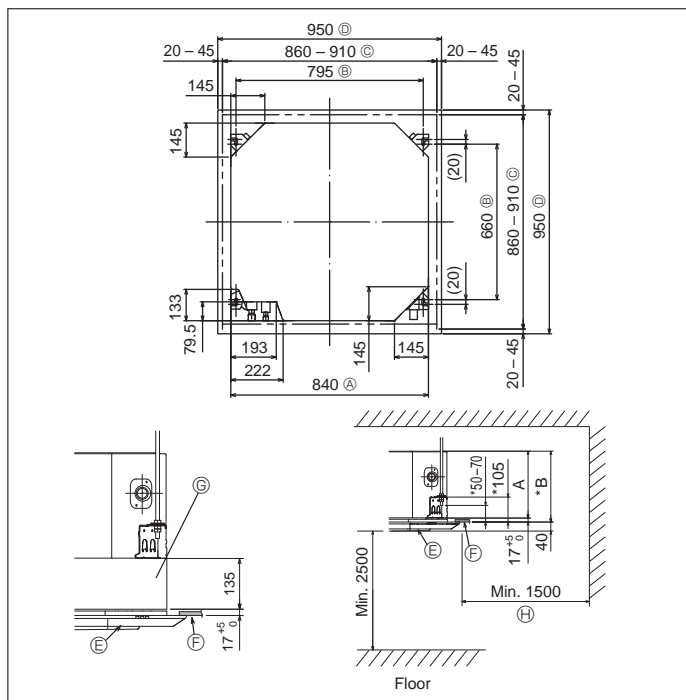

Fig. 3-2

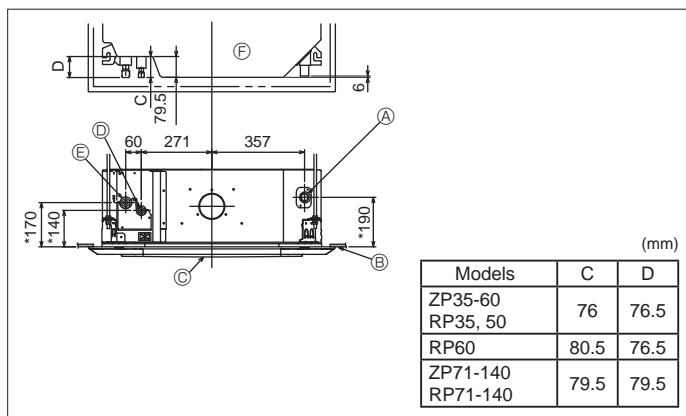

Fig. 3-3

3.1. Check the indoor unit accessories (Fig. 3-1)

The indoor unit should be supplied with the following accessories.

	Accessory name	Qty
①	Installation template (top of the package)	1
	Washers (with insulation)	4
②	Washers (without insulation)	4
	Pipe cover (for refrigerant piping joint)	
	Small diameter	1
	Large diameter	1
④	Band (large)	8
⑤	Band (small)	1
⑥	Drain socket	1
⑦	Insulation	1
⑧	Flare nut 1/4F (RP60)	1

3.2. Ceiling openings and suspension bolt installation locations (Fig. 3-2)

⚠ Caution:

Install the indoor unit at least 2.5 m above floor or grade level.

For appliances not accessible to the general public.

- Using the installation template (top of the package) and the gauge (supplied as an accessory with the grille), make an opening in the ceiling so that the main unit can be installed as shown in the diagram. (The method for using the template and the gauge is shown.)

* Before using, check the dimensions of template and gauge, because they change due to fluctuations of temperature and humidity.

* The dimensions of ceiling opening can be regulated within the range shown in Fig. 3-2; so center the main unit against the opening of ceiling, ensuring that the respective opposite sides on all sides of the clearance between them becomes identical.

- Use M10 (3/8") suspension bolts.

* Suspension bolts are to be procured at the field.

- Install securely, ensuring that there is no clearance between the ceiling panel & grille, and between the main unit & grille.

- Ⓐ Outer side of main unit
- Ⓑ Bolt pitch
- Ⓒ Ceiling opening
- Ⓓ Outer side of Grille
- Ⓔ Grille
- Ⓕ Ceiling
- Ⓖ Multi functional casement (option)
- Ⓗ Entire periphery

* Note that the space between ceiling panel of the unit and ceiling slab, etc. must be 7 mm or more.

* When the optional multi-functional casement is installed, add 135 mm to the dimensions marked on the figure.

(mm)

Models	A	B
ZP35-60 RP35-71	241	258
ZP71-140 RP100-140	281	298

3.3. Refrigerant and drainage piping locations of indoor unit (Fig. 3-3)

The figure marked with * in the drawing represent the dimensions of the main unit excluding those of the optional multi function casement.

- Ⓐ Drain pipe
- Ⓑ Ceiling
- Ⓒ Grille
- Ⓓ Refrigerant pipe (liquid)
- Ⓔ Refrigerant pipe (gas)
- Ⓕ Main unit

* When the optional multi-functional casement is installed, add 135 mm to the dimensions marked on the figure.

3. Installing the indoor unit

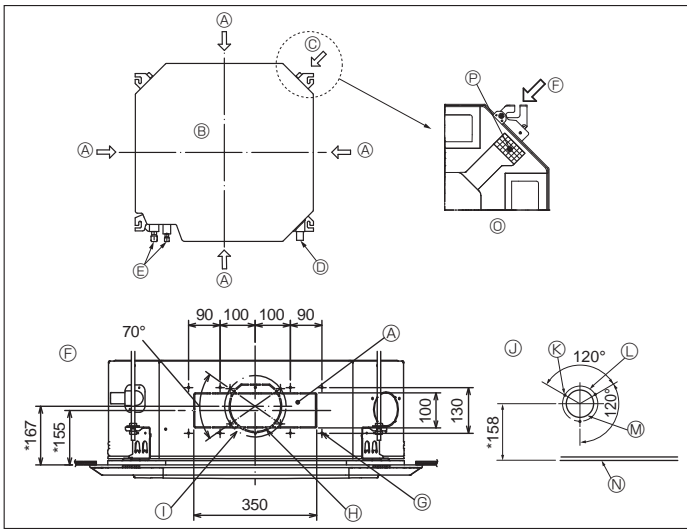

Fig. 3-4

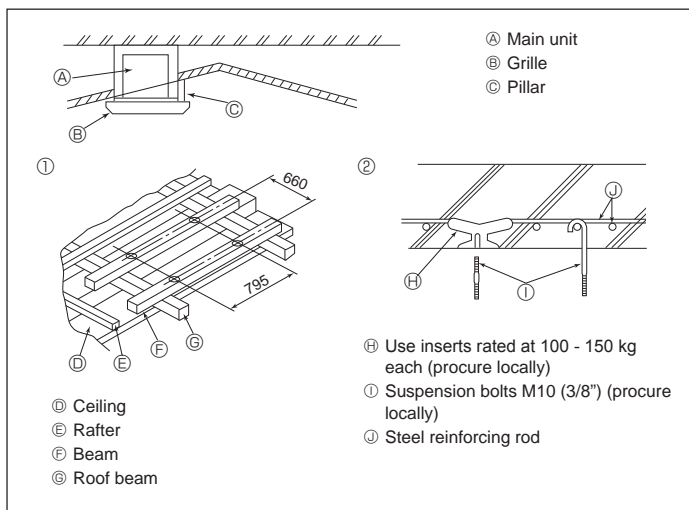

Fig. 3-5

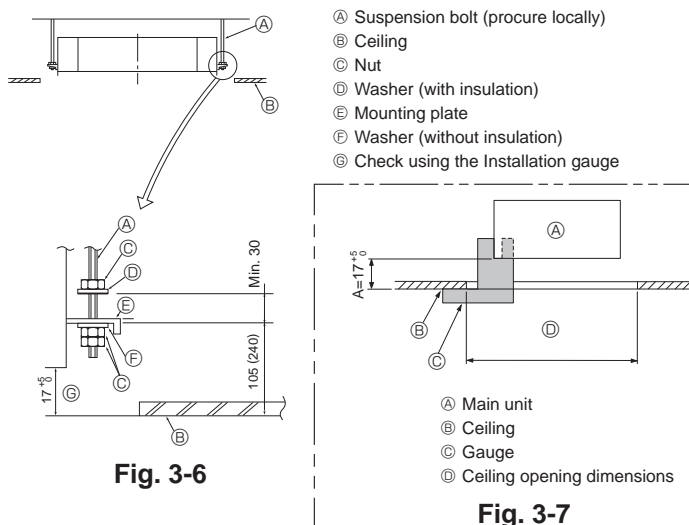

Fig. 3-6

Fig. 3-7

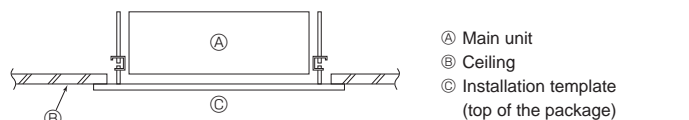

Fig. 3-8

3.4. Branch duct hole and fresh air intake hole (Fig. 3-4)

At the time of installation, use the duct holes (cut out) located at the positions shown in Fig. 3-4, as and when required.

- A fresh air intake hole for the optional multi function casement can also be made.

Note:

- The figure marked with * in the drawing represent the dimensions of the main unit excluding those of the optional multi function casement.
- When installing the optional multi function casement, add 135 mm to the dimensions marked on the figure.
- When installing the branch ducts, be sure to insulate adequately. Otherwise condensation and dripping may occur.
- When installing the fresh air intake hole, be sure to remove the insulator $\text{\textcircled{P}}$ that is pasted on the indoor unit.
- When external air is input directly through the main unit, intake-air volume should be 5% or less of indoor unit air volume.
- To input the external air, the duct fan and dust collecting filter to prevent drawing in dust and other particles are necessary. For details, see "Fresh air intake volume & static pressure characteristics" in the P series DATA BOOK.
- When external air is input into the main unit, the operation noise can be larger.

- | | |
|---|--|
| $\text{\textcircled{A}}$ Branch duct hole | $\text{\textcircled{O}}$ $\phi 175$ burring hole pitch |
| $\text{\textcircled{B}}$ Main unit | $\text{\textcircled{Q}}$ Fresh air intake hole diagram |
| $\text{\textcircled{C}}$ Fresh air intake hole | $\text{\textcircled{R}}$ 3-4x10 tapping screws |
| $\text{\textcircled{D}}$ Drain pipe | $\text{\textcircled{S}}$ $\phi 125$ burring hole pitch |
| $\text{\textcircled{E}}$ Refrigerant pipe | $\text{\textcircled{T}}$ $\phi 100$ cut out hole |
| $\text{\textcircled{F}}$ Branch duct hole diagram (view from either side) | $\text{\textcircled{U}}$ Ceiling |
| $\text{\textcircled{G}}$ 14-4x10 tapping screws | $\text{\textcircled{V}}$ Detailed figure of removing the insulator |
| $\text{\textcircled{H}}$ $\phi 150$ cut out hole | $\text{\textcircled{W}}$ Insulation |

3.5. Suspension structure (Give site of suspension strong structure) (Fig. 3-5)

• The ceiling work differs according to the construction of the building. Building constructors and interior decorators should be consulted for details.

- (1) Extent of ceiling removal: The ceiling must be kept completely horizontal and the ceiling foundation (framework: wooden slats and slat holders) must be reinforced in order to protect the ceiling from vibration.
- (2) Cut and remove the ceiling foundation.
- (3) Reinforce the ends of the ceiling foundation where it has been cut and add ceiling foundation for securing the ends of the ceiling board.
- (4) When installing the indoor unit on a slanted ceiling, attach a pillar between the ceiling and the grille and set so that the unit is installed horizontally.

① Wooden structures

- Use tie beams (single storied houses) or second floor beams (2 story houses) as reinforcing members.
- Wooden beams for suspending air conditioners must be sturdy and their sides must be at least 6 cm long if the beams are separated by not more than 90 cm and their sides must be at least 9 cm long if the beams are separated by as much as 180 cm. The size of the suspension bolts should be $\phi 10$ (3/8"). (The bolts do not come with the unit.)

② Ferro-concrete structures

Secure the suspension bolts using the method shown, or use steel or wooden hangers, etc. to install the suspension bolts.

3.6. Unit suspension procedures (Fig. 3-6)

Suspend the main unit as shown in the diagram.

Figures given in parentheses represent the dimensions in case of installing optional multi function casement.

1. In advance, set the parts onto the suspension bolts in the order of the washers (with insulation), washers (without insulation) and nuts (double).
 - Fit the washer with cushion so that the insulation faces downward.
 - In case of using upper washers to suspend the main unit, the lower washers (with insulation) and nuts (double) are to be set later.
2. Lift the unit to the proper height of the suspension bolts to insert the mounting plate between washers and then fasten it securely.
3. When the main unit cannot be aligned against the mounting plate on the ceiling, it is adjustable owing to a slot provided on the mounting plate.
 - Make sure that A is performed within 17 - 22 mm. Damage could result by failing to adhere to this range. (Fig. 3-7)

⚠ Caution:

Use the top half of the box as a protective cover to prevent dust or debris from getting inside the unit prior to installation of the decorative cover or when applying ceiling materials.

3.7. Confirming the position of main unit and tightening the suspension bolts (Fig. 3-8)

- Using the gauge attached to the grille, ensure that the bottom of the main unit is properly aligned with the opening of the ceiling. Be sure to confirm this, otherwise condensation may form and drip due to air leakage, etc.
- Confirm that the main unit is horizontally levelled, using a level or a vinyl tube filled with water.
- After checking the position of the main unit, tighten the nuts of the suspension bolts securely to fasten the main unit.
- The installation template (top of the package) can be used as a protective sheet to prevent dust from entering the main unit when the grilles are left unattached for a while or when the ceiling materials are to be lined after installation of the unit is finished.

* As for the details of fitting, refer to the instructions given on the Installation template. (top of the package)

4. Installing the refrigerant piping

4.1. Precautions

For devices that use R410A refrigerant

- Use alkylbenzene oil (small amount) as the refrigeration oil applied to the flared sections.
- Use C1220 copper phosphorus for copper and copper alloy seamless pipes, to connect the refrigerant pipes. Use refrigerant pipes with the thicknesses specified in the table below. Make sure the insides of the pipes are clean and do not contain any harmful contaminants such as sulfuric compounds, oxidants, debris, or dust.

Warning:

When installing or relocating, or servicing the air conditioner, use only the specified refrigerant (R410A) to charge the refrigerant lines. Do not mix it with any other refrigerant and do not allow air to remain in the lines. If air is mixed with the refrigerant, then it can be the cause of abnormal high pressure in the refrigerant line, and may result in an explosion and other hazards. The use of any refrigerant other than that specified for the system will cause mechanical failure or system malfunction or unit breakdown. In the worst case, this could lead to a serious impediment to securing product safety.

ø6.35 thickness 0.8 mm	ø9.52 thickness 0.8 mm
ø12.7 thickness 0.8 mm	ø15.88 thickness 1.0 mm

- Do not use pipes thinner than those specified above.

4.2. Connecting pipes (Fig. 4-1)

- When commercially available copper pipes are used, wrap liquid and gas pipes with commercially available insulation materials (heat-resistant to 100 °C or more, thickness of 12 mm or more).
- Apply thin layer of refrigerant oil to pipe and joint seating surface before tightening flare nut.
- Use 2 wrenches to tighten piping connections.
- Use refrigerant piping insulation provided to insulate indoor unit connections. Insulate carefully.
- After connecting the refrigerant piping to the indoor unit, be sure to test the pipe connections for gas leakage with nitrogen gas. (Check that there is no refrigerant leakage from the refrigerant piping to the indoor unit.)
- Use flared nut installed to this indoor unit.
- In case of reconnecting the refrigerant pipes after detaching, make the flared part of pipe re-fabricated.

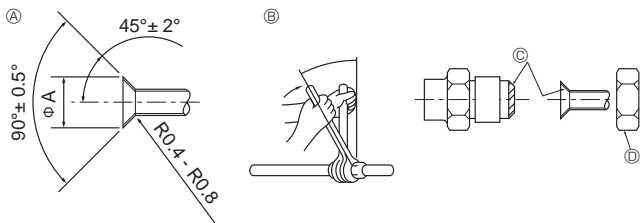

Fig. 4-1

A Flare cutting dimensions

Copper pipe O.D. (mm)	Flare dimensions øA dimensions (mm)
ø6.35	8.7 - 9.1
ø9.52	12.8 - 13.2
ø12.7	16.2 - 16.6
ø15.88	19.3 - 19.7

B Flare nut tightening torque

Copper pipe O.D. (mm)	Flare nut O.D. (mm)	Tightening torque (N·m)
ø6.35	17	14 - 18
ø6.35	22	34 - 42
ø9.52	22	34 - 42
ø12.7	26	49 - 61
ø15.88	29	68 - 82

C Apply refrigerating machine oil over the entire flare seat surface.

D Use correct flare nuts meeting the pipe size of the outdoor unit.

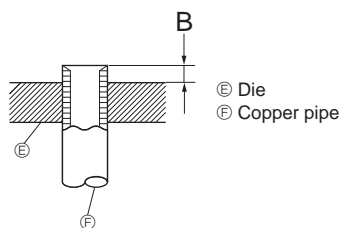

Fig. 4-2

Copper pipe O.D. (mm)	B (mm)	
	Flare tool for R410A	
	Clutch type	
ø6.35 (1/4")	0 - 0.5	
ø9.52 (3/8")	0 - 0.5	
ø12.7 (1/2")	0 - 0.5	
ø15.88 (5/8")	0 - 0.5	

Available pipe size

	ZP35-60 RP35, 50	RP60	ZP71-140 RP71-140
Liquid side	ø6.35 O	ø6.35	—
	—	ø9.52 O	ø9.52 O
Gas side	ø12.7 O	ø15.88 O	ø15.88 O

O : Factory flare nut attachment to the heat exchanger.

Warning:

- Be careful of flying flare nut! (Internally pressurized)

Remove the flare nut as follows:

1. Loosen the nut until you hear a hissing noise.
 2. Do not remove the nut until the gas has been completely released (i.e., hissing noise stops).
 3. Check that the gas has been completely released, and then remove the nut.
- When installing the unit, securely connect the refrigerant pipes before starting the compressor.

4. Installing the refrigerant piping

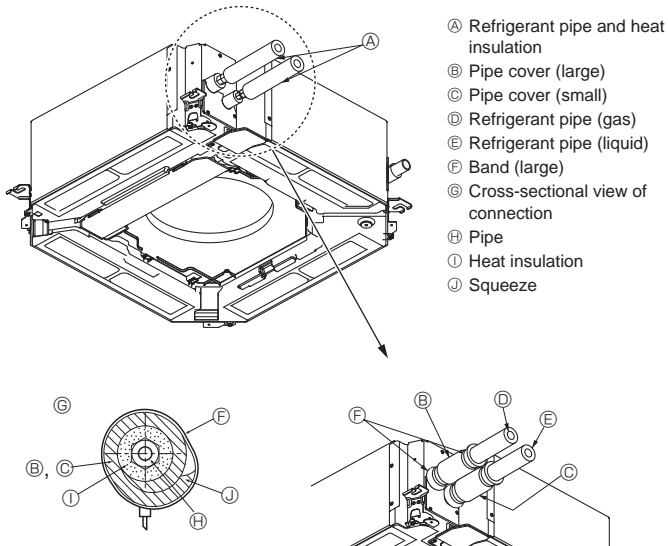

Fig. 4-3

Heat insulation for refrigerant pipes (Fig. 4-3)

- 1 Wrap the enclosed large-sized pipe cover around the gas pipe, making sure that the end of the pipe cover touches the side of the unit.
- 2 Wrap the enclosed small-sized pipe cover around the liquid pipe, making sure that the end of the pipe cover touches the side of the unit.
- 3 Secure both ends of each pipe cover with the enclosed bands. (Attach the bands 20 mm from the ends of the pipe cover.)

4.3. For twin/triple/quadruple combination

Refer to the outdoor unit installation manual.

Some outdoor units cannot be used in a simultaneous twin/triple/quadruple system.

5. Drainage piping work

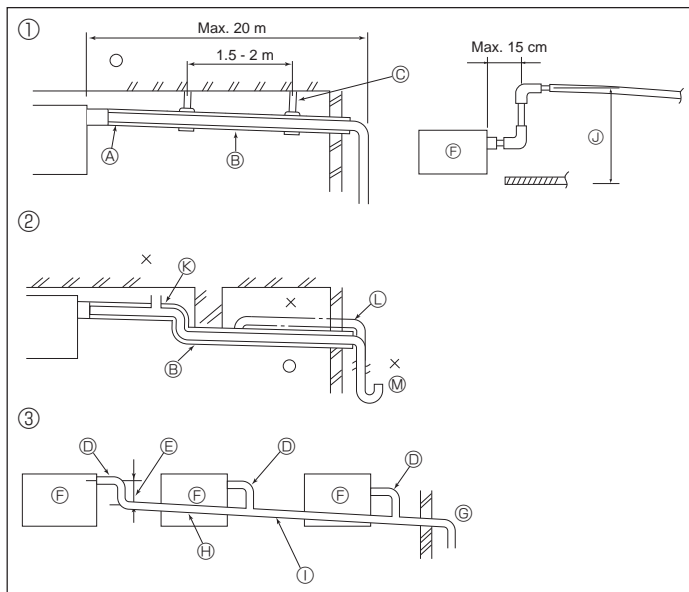

Fig. 5-1

5.1. Drainage piping work (Fig. 5-1)

- The indoor parts of the drain pipe should be wrapped with polyethylene foam insulation materials (specific gravity of 0.03, thickness of 9 mm or more).
- Use VP25 (O.D. ø32 PVC TUBE) for drain piping and provide 1/100 or more downward slope.
- Be sure to connect the piping joints using a PVC type adhesive.
- Observe the figure for piping work.
- Use the included drain hose to change the extraction direction.
- When performing the drainage piping work, be sure to use the support metal holders. If a load is applied to the drain socket that damages the hose or causes the hose to become detached, water leakage may result.

- | | |
|--|--|
| ① Correct piping | Ⓞ Make the piping size large for grouped piping. |
| ② Wrong piping | ⓓ Downward slope (1/100 or more) |
| ③ Grouped piping | Ⓛ O.D. ø38 PVC TUBE for grouped piping (9 mm or more insulation) |
| Ⓐ Insulation (9 mm or more) | Ⓤ Up to 85 cm |
| Ⓑ Downward slope (1/100 or more) | Ⓚ Air bleeder |
| Ⓒ Support metal | Ⓛ Raised |
| Ⓓ O.D. ø32 PVC TUBE | Ⓜ Odor trap |
| Ⓔ Make it as large as possible (about 10 cm) | |
| Ⓕ Main unit | |

1. Connect the drain socket (supplied with the unit) to the drain port. (Fig. 5-2)
(Fix the tube using PVC adhesive then secure it with a band.)

2. Install a locally purchased drain pipe (PVC pipe, O.D. ø32).
(Fix the pipe using PVC adhesive then secure it with a band.)

3. Check that drain flows smoothly.

4. Insulate the drain port and socket with insulating material, then secure the material with a band. (Both insulating material and band are supplied with the unit.)

5. Insulate the tube and pipe. (PVC pipe, O.D. ø32)

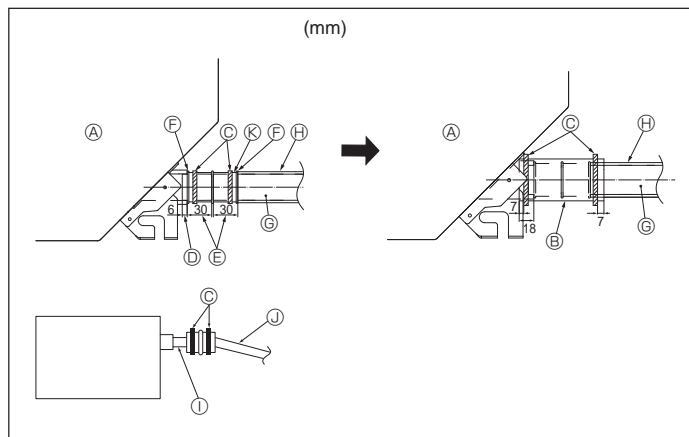

Fig. 5-2

- | | |
|----------------------------|---|
| Ⓐ Main unit | Ⓞ Drain pipe (O.D. ø32 PVC TUBE) |
| Ⓑ Insulating material | ⓓ Insulating material (purchased locally) |
| Ⓒ Band (large) | Ⓛ Transparent PVC pipe |
| Ⓓ Drain port (transparent) | Ⓤ O.D. ø32 PVC TUBE (Slope 1/100 or more) |
| Ⓔ Insertion margin | Ⓚ Drain socket |
| Ⓕ Matching | |

6. Electrical work

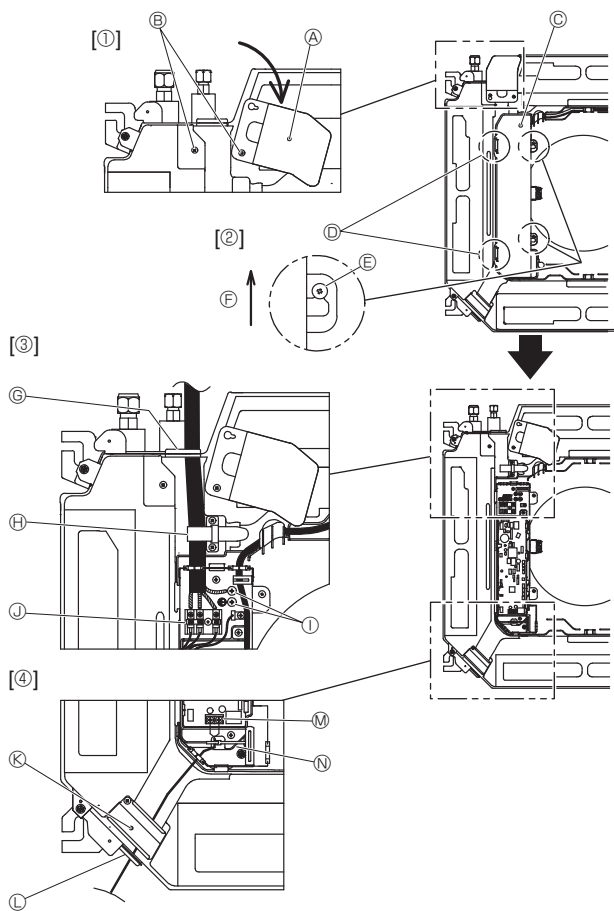

Fig. 6-1

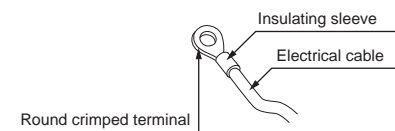

Fig. 6-2

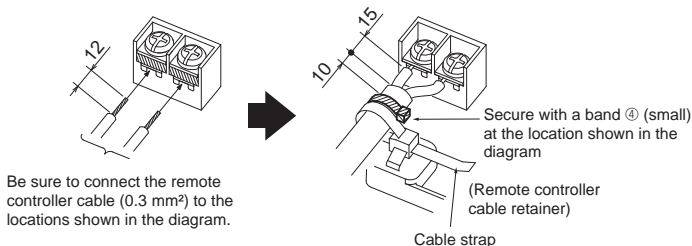

Fig. 6-3

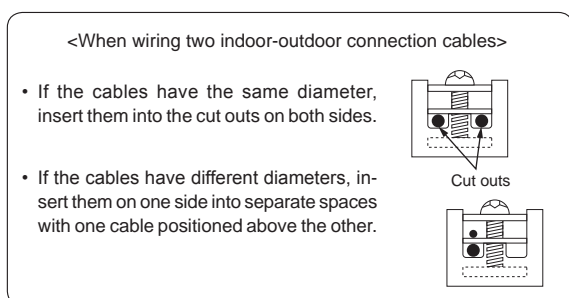

Fig. 6-5

6.1. Indoor unit (Fig. 6-1)

1. Loosen the two screws securing the electrical wiring service panel, and then turn the electrical wiring service panel. [Fig. 6-1 ①]
 2. Loosen the two screws securing the electrical box cover, then slide the electrical box cover. [Fig. 6-1 ②]
 3. Pass the power cable, indoor/outdoor unit connecting cable and earth cable through the wiring entries given in the diagram. [Fig. 6-1 ③]
Put the sheath portion of the power cable and indoor/outdoor connecting cable into the electrical box.
Use round crimped terminals for the indoor-outdoor connection terminal and the optional power supply terminal kit. [Fig. 6-2]
If you cannot use round crimped terminals, following the procedure in Fig. 6-3 to 6-6.
Refer to 6.1.1. and 6.1.2. for the connection.
 4. Pass and wire the remote controller cable through the wiring entries given in the diagram. [Fig. 6-1 ④, Fig. 6-3]
Refer to 6.1.1. and 6.1.2. for the connection.
- Do not allow slackening of the terminal screws.

Screw tightening torque

	Tightening torque (N·m)
Remote controller terminal board	1.2 ± 0.1
Indoor-outdoor connection terminal board	1.6 ± 0.1
Earth cable	1.6 ± 0.1

- Leave excess cable so that the electrical box can be suspended below the unit during servicing (approx. 50 to 100 mm).

- ① Electrical wiring service panel
- ② Screw
- ③ Electrical box cover
- ④ Temporary hook for electrical box cover
- ⑤ Screw
- ⑥ Slide direction of the electrical box cover
- ⑦ Entry for power cable and indoor/outdoor unit connecting cable
- ⑧ Secure with the cable strap.
- ⑨ Earth cable
- ⑩ Indoor/outdoor unit connecting terminal
- ⑪ Electrical wiring service panel (remote controller)
- ⑫ Entry for wired remote controller
- ⑬ Wired remote controller terminal
- ⑭ Secure with the cable strap.

⚠ Caution:

- Wiring for remote controller cable shall be apart (5 cm or more) from power source wiring so that it is not influenced by electric noise from power source wiring.

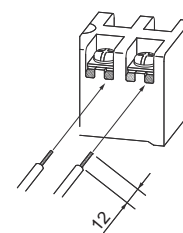

- The U-shaped groove opens if you push the screw head after the screw is loosened.

Fig. 6-4

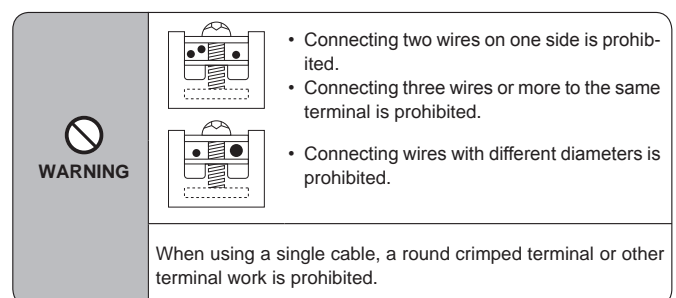

Fig. 6-6

6. Electrical work

6.1.1. Indoor unit power supplied from outdoor unit

The following connection patterns are available.

The outdoor unit power supply patterns vary on models.

1:1 System

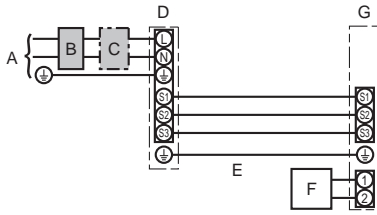

- A Outdoor unit power supply
- B Earth leakage breaker
- C Wiring circuit breaker or isolating switch
- D Outdoor unit
- E Indoor unit/outdoor unit connecting cables
- F Remote controller
- G Indoor unit

* Affix label A that is included with the manuals near each wiring diagram for the indoor and outdoor units.

Simultaneous twin/triple/quadruple system

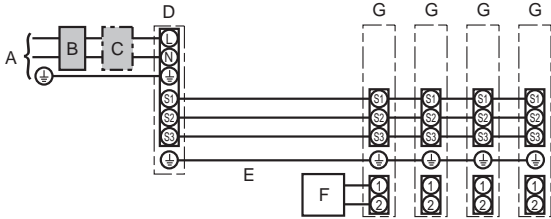

- A Outdoor unit power supply
- B Earth leakage breaker
- C Wiring circuit breaker or isolating switch
- D Outdoor unit
- E Indoor unit/outdoor unit connecting cables
- F Remote controller
- G Indoor unit

* Affix label A that is included with the manuals near each wiring diagram for the indoor and outdoor units.

Note:

Some units cannot be used in a simultaneous twin/triple/quadruple system. Refer to the outdoor unit installation manual for details.

Indoor unit model		PLA	
Wiring Wire No. x size (mm ²)	Indoor unit-Outdoor unit	*1	3 × 1.5 (polar)
	Indoor unit-Outdoor unit earth	*1	1 × Min. 1.5
	Indoor unit earth		1 × Min. 1.5
Circuit rating	Remote controller-Indoor unit	*2	2 × 0.3 (Non-polar)
	Indoor unit (Heater) L-N	*3	—
	Indoor unit-Outdoor unit S1-S2	*3	230 VAC
	Indoor unit-Outdoor unit S2-S3	*3	24 VDC
	Remote controller-Indoor unit	*3	12 VDC

*1. <For 35-140 outdoor unit application>

Max. 45 m

If 2.5 mm² used, Max. 50 m

If 2.5 mm² used and S3 separated, Max. 80 m

<For 200/250 outdoor unit application>

Max. 18 m

If 2.5 mm² used, Max. 30 m

If 4 mm² used and S3 separated, Max. 50 m

If 6 mm² used and S3 separated, Max. 80 m

*2. Max. 500 m

(When using 2 remote controllers, the maximum wiring length for the remote controller cables is 200 m.)

*3. The figures are NOT always against the ground.

S3 terminal has 24 VDC against S2 terminal. However between S3 and S1, these terminals are not electrically insulated by the transformer or other device.

Notes: 1. Wiring size must comply with the applicable local and national code.

2. Power supply cords and indoor unit/outdoor unit connecting cords shall not be lighter than polychloroprene sheathed flexible cord. (Design 60245 IEC 57)

3. Install an earth longer than other cables.

4. Indoor and outdoor connecting wires have polarities. Make sure to match the terminal number (S1, S2, S3) for correct wirings.

5. Wiring for remote controller cable shall be apart (5 cm or more) from power source wiring so that it is not influenced by electric noise from power source wiring.

Warning:

Never splice the power cable or the indoor-outdoor connection cable, otherwise it may result in a smoke, a fire or communication failure.

6. Electrical work

6.1.2. Separate indoor unit/outdoor unit power supplies (For PUHZ application only)

The following connection patterns are available.

The outdoor unit power supply patterns vary on models.

1:1 System

* The indoor power supply terminal kit is required.

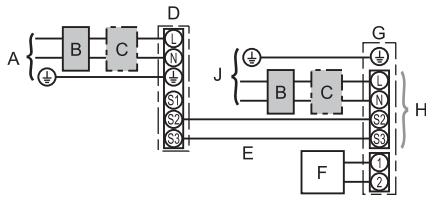

- A Outdoor unit power supply
- B Earth leakage breaker
- C Wiring circuit breaker or isolating switch
- D Outdoor unit
- E Indoor unit/outdoor unit connecting cables
- F Remote controller
- G Indoor unit
- H Option
- J Indoor unit power supply

* Affix label B that is included with the manuals near each wiring diagram for the indoor and outdoor units.

Simultaneous twin/triple/quadruple system

* The indoor power supply terminal kits are required.

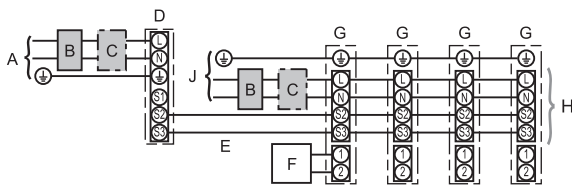

- A Outdoor unit power supply
- B Earth leakage breaker
- C Wiring circuit breaker or isolating switch
- D Outdoor unit
- E Indoor unit/outdoor unit connecting cables
- F Remote controller
- G Indoor unit
- H Option
- J Indoor unit power supply

* Affix label B that is included with the manuals near each wiring diagram for the indoor and outdoor units.

Note:

Some units cannot be used in a simultaneous twin/triple/quadruple system. Refer to the outdoor unit installation manual for details.

If the indoor and outdoor units have separate power supplies, refer to the table below. If the indoor power supply terminal kit is used, change the indoor unit electrical box wiring referring to the figure in the right and the DIP switch settings of the outdoor unit control board.

Indoor power supply terminal kit (option)	Required								
Indoor unit electrical box connector connection change	Required								
Label affixed near each wiring diagram for the indoor and outdoor units	Required								
Outdoor unit DIP switch settings (when using separate indoor unit/outdoor unit power supplies only)	<table border="1" style="margin-left: auto; margin-right: auto;"> <tr> <td>ON</td> <td></td> <td></td> <td>3</td> </tr> <tr> <td>OFF</td> <td>1</td> <td>2</td> <td></td> </tr> </table> <p style="text-align: center;">(SW8) Set the SW8-3 to ON.</p>	ON			3	OFF	1	2	
ON			3						
OFF	1	2							

* There are 3 types of labels (labels A, B and C). Affix the appropriate labels to the units according to the wiring method.

<Replacing the indoor unit terminal block>

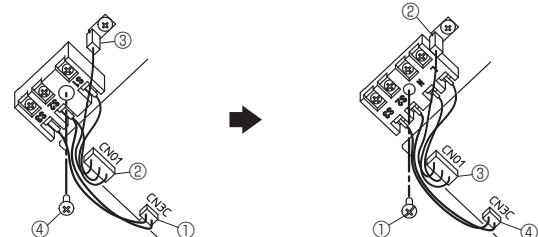

- ① Disconnect connector CN3C (blue) from the indoor controller board.
- ② Disconnect connector CN01 (black) from the indoor controller board.
- ③ Disconnect the tab terminal.
- ④ Remove the screw from the terminal block.

Install the optional Power supply terminal kit. Refer to the installation manual that comes with the optional Power supply terminal kit for details.

- ① Secure the terminal block with the screw.
- ② Insert the tab terminal.
- ③ Connect connector CN01 (black) to the indoor controller board.
- ④ Connect connector CN3C (blue) to the indoor controller board.

Indoor unit model		PLA
Indoor unit power supply		~/N (single), 50 Hz, 230 V
Indoor unit input capacity Main switch (Breaker)	*1	16 A
Wiring Wire No. x size (mm ²)	Indoor unit power supply & earth	3 x Min. 1.5
	Indoor unit-Outdoor unit	*2 2 x Min. 0.3
	Indoor unit-Outdoor unit earth	-
	Remote controller-Indoor unit	*3 2 x 0.3 (Non-polar)
Circuit rating	Indoor unit L-N	*4 230 VAC
	Indoor unit-Outdoor unit S1-S2	*4 -
	Indoor unit-Outdoor unit S2-S3	*4 24 VDC
	Remote controller-Indoor unit	*4 12 VDC

*1. A breaker with at least 3.0 mm contact separation in each pole shall be provided. Use earth leakage breaker (NV).

The breaker shall be provided to ensure disconnection of all active phase conductors of the supply.

*2. Max. 120 m

*3. Max. 500 m

(When using 2 remote controllers, the maximum wiring length for the remote controller cables is 200 m.)

*4. The figures are NOT always against the ground.

Notes: 1. Wiring size must comply with the applicable local and national code.

2. Power supply cords and indoor unit/outdoor unit connecting cords shall not be lighter than polychloroprene sheathed flexible cord. (Design 60245 IEC 57)

3. Install an earth longer than other cables.

4. Wiring for remote controller cable shall be apart (5 cm or more) from power source wiring so that it is not influenced by electric noise from power source wiring.

Warning:

Never splice the power cable or the indoor-outdoor connection cable, otherwise it may result in a smoke, a fire or communication failure.

6. Electrical work

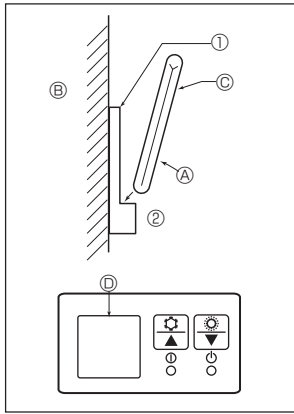

Fig. 6-7

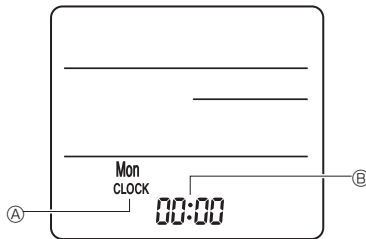

Fig. 6-8

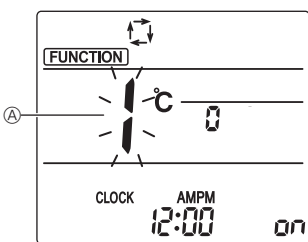
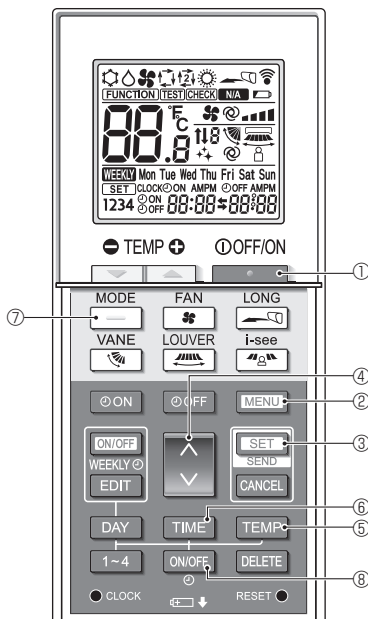

Fig. 6-9

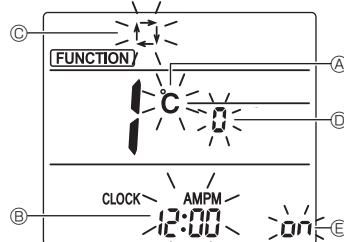

Fig. 6-10

6.2. Remote controller

6.2.1. For wired remote controller

1) 2 remote controllers setting

If 2 remote controllers are connected, set one to "Main" and the other to "Sub". For setting procedures, refer to "Function selection of remote controller" in the operation manual for the indoor unit.

6.2.2. For wireless remote controller

1) Installation area

- Area in which the remote controller is not exposed to direct sunshine.
- Area in which there is no nearby heating source.
- Area in which the remote controller is not exposed to cold (or hot) winds.
- Area in which the remote controller can be operated easily.
- Area in which the remote controller is beyond the reach of children.

2) Installation method (Fig. 6-7)

① Attach the remote controller holder to the desired location using 2 tapping screws.

② Place the lower end of the controller into the holder.

Ⓐ Remote controller Ⓑ Wall Ⓒ Display panel Ⓓ Receiver

- The signal can travel up to approximately 7 meters (in a straight line) within 45 degrees to both right and left of the center line of the receiver.

3) Setting (Clock setting) (Fig. 6-8)

① Insert batteries or press the ● CLOCK button with something sharp.

[CLOCK] Ⓐ and [:] Ⓑ blinks.

② Press the RESET ● button with something sharp.

③ Press the ⬆ button to set the time.

Press the DAY button to set the Day.

④ Press the ● CLOCK button with something sharp at the end.

[CLOCK] and [:] lighted.

4) Initial setting

The following settings can be made in the initial setting mode.

Item	Setting	Fig. 6-10
Temperature unit	°C/°F	Ⓐ
Time display	12-hour format/24-hour format	Ⓑ
AUTO mode	Single set point/Dual set point	Ⓒ
Pair No.	0-3	Ⓓ
Backlight	On/Off	Ⓔ

4-1. Switching to the initial setting mode

1. Press the ● button ① to stop the air conditioner.

2. Press the MENU button ②.

The Function setting screen will be displayed and the function No. Ⓐ will blink. (Fig. 6-9)

Press the ⬆ button ④ to change the function No.

3. Check that function No. "1" is displayed, and then press the SET button ③.

The display setting screen will be displayed. (Fig. 6-10)

4-2. Changing the temperature unit Ⓐ

Press the TEMP button ⑤.

Each time the TEMP button ⑤ is pressed, the setting switches between C and F.

C: The temperature is displayed in degrees Celsius.

F: The temperature is displayed in degrees Fahrenheit.

4-3. Changing the time display Ⓑ

Press the TIME button ⑥.

Each time the TIME button ⑥ is pressed, the setting switches between 12:00^{AMPM} and 24:00.

12:00^{AMPM}: The time is displayed in the 12-hour format.

24:00: The time is displayed in the 24-hour format.

4-4. Changing the AUTO mode Ⓒ

Press the button ⑦.

Each time the button ⑦ is pressed, the setting switches between  and .

: The AUTO mode operates as the usual automatic mode.

: The AUTO mode operates using dual set points.

4-5. Changing the pair No. Ⓓ



Press the ⬆ button ④.

Each time the ⬆ button ④ is pressed, the pair No. 0-3 changes.

Pair No. of wireless remote controller	Indoor PC board
0	Initial setting
1	Cut J41
2	Cut J42
3	Cut J41, J42

4-6. Changing the backlight setting Ⓔ

Press the ON/OFF button ⑧.

Each time the ON/OFF button ⑧ is pressed, the setting switches between  and .

: The backlight comes on when a button is pressed.

: The backlight does not come on when a button is pressed.

6. Electrical work

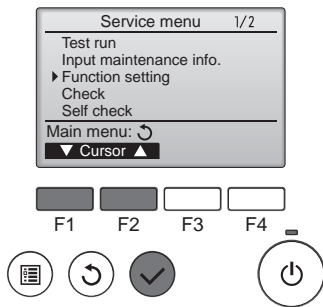

Fig. 6-11

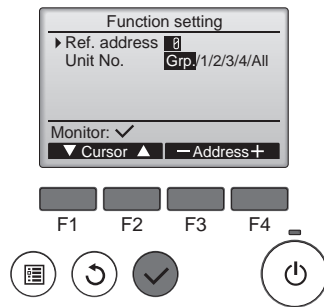

Fig. 6-12

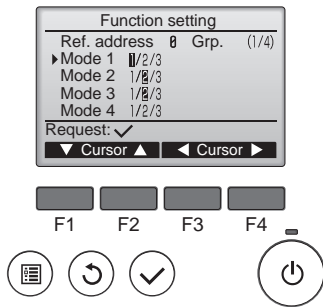

Fig. 6-13

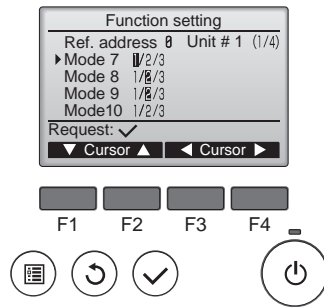

Fig. 6-14

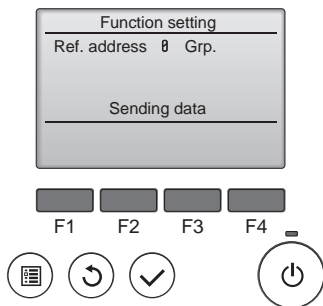

Fig. 6-15

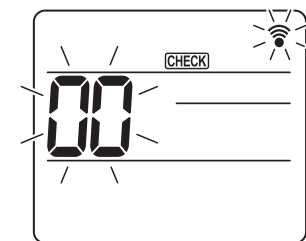

Fig. 6-16

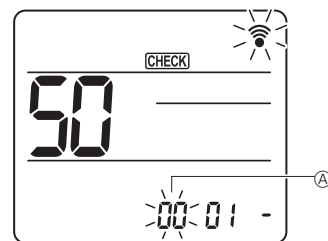

Fig. 6-17

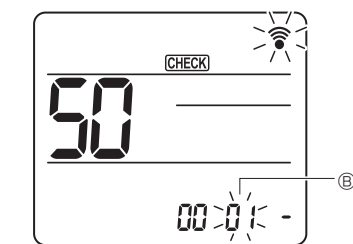

Fig. 6-18

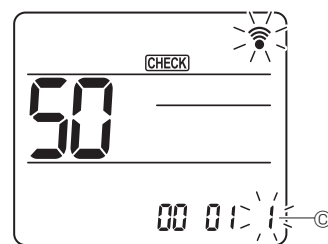

Fig. 6-19

6.3. Function settings

6.3.1. By wired remote controller

- ① (Fig. 6-11)
 - Select "Service" from the Main menu, and press the [SELECT] button.
 - Select "Function settings" with the [F1] or [F2] button, and press the [SELECT] button.
- ② (Fig. 6-12)
 - Set the indoor unit refrigerant addresses and unit numbers with the [F1] through [F4] buttons, and then press the [SELECT] button to confirm the current setting.

<Checking the Indoor unit No.>

When the [SELECT] button is pressed, the target indoor unit will start fan operation. If the unit is common or when running all units, all indoor units for the selected refrigerant address will start fan operation.

- ③ (Fig. 6-13)
 - When data collection from the indoor units is completed, the current settings appears highlighted. Non-highlighted items indicate that no function settings are made. Screen appearance varies depending on the "Unit No." setting.
- ④ (Fig. 6-14)
 - Use the [F1] or [F2] button to move the cursor to select the mode number, and change the setting number with the [F3] or [F4] button.
- ⑤ (Fig. 6-15)
 - When the settings are completed, press the [SELECT] button to send the setting data from the remote controller to the indoor units.
 - When the transmission is successfully completed, the screen will return to the Function setting screen.

6.3.2. By wireless remote controller

- ① Going to the function select mode
 - Press the [MENU] button between of 5 seconds. (Start this operation from the status of remote controller display turned off.) [CHECK] is lighted and "00" blinks. (Fig. 6-16)
 - Press the [DOWN] button to set the "50".
 - Direct the wireless remote controller toward the receiver of the indoor unit and press the [SET] button.
- ② Setting the unit number
 - Press the [DOWN] button to set unit number ^A. (Fig. 6-17)
 - Direct the wireless remote controller toward the receiver of the indoor unit and press the [SET] button.
- ③ Select a mode
 - Press the [DOWN] button to set Mode number ^B. (Fig. 6-18)
 - Direct the wireless remote controller toward the receiver of the indoor unit and press the [SET] button.

Current setting number: 1=1 beep (1 second)
 2=2 beep (1 second each)
 3=3 beep (1 second each)
- ④ Selecting the setting number
 - Use the [DOWN] button to change the Setting number ^C. (Fig. 6-19)
 - Direct the wireless remote controller toward the receiver of the indoor unit and press the [SET] button.
- ⑤ To select multiple functions continuously
 - Repeat select ③ and ④ to change multiple function settings continuously.
- ⑥ Complete function selection
 - Direct the wireless remote controller toward the sensor of the indoor unit and press the [OFF/ON] button.

Note:

Make the above settings on Mr. Slim units as necessary.

- Table 1 summarizes the setting options for each mode number.
- Be sure to write down the settings for all functions if any of the initial settings has been changed after the completion of installation work.

6. Electrical work

Function table (Table 1)

Select unit number 00

Mode	Settings	Mode no.	Setting no.	Initial setting	setting
Power failure automatic recovery	Not available	01	1		
	Available *1		2	O *2	
Indoor temperature detecting	Indoor unit operating average	02	1	O	
	Set by indoor unit's remote controller		2		
	Remote controller's internal sensor		3		
LOSSNAY connectivity	Not Supported	03	1	O	
	Supported (indoor unit is not equipped with outdoor-air intake)		2		
	Supported (indoor unit is equipped with outdoor-air intake)		3		
Power voltage	240 V	04	1		
	220 V, 230 V		2	O	

Select unit numbers 01 to 03 or all units (AL [wired remote controller]/07 [wireless remote controller])

Mode	Settings	Mode no.	Setting no.	Initial setting	setting
Filter sign	100Hr	07	1		
	2500Hr		2	O	
	No filter sign indicator		3		
Fan speed	Silent (low ceiling)	08	1		
	Standard		2	O	
	High ceiling		3		
No. of air outlets	4 directions	09	1	O	
	3 directions		2		
	2 directions		3		
Installed options (high efficiency filter)	Not supported	10	1	O	
	Supported		2		
Up/down vane setting	Downward setting (vaner angle setup ③)	11	1		
	Middle setting (vaner angle setup ①)		2		
	Draft - less setting (vaner angle setup ②)		3	O	
3D i-see Sensor positioning	Position ①	12 *3	1		
	Position ②		2		
	Position ③ (Default)		3	O	
3D i-see Sensor ceiling height setting (when installing the 3D i-see Sensor panel)	Low ceiling (ceiling height: less than 2.7 m)	26	1		
	Standard (ceiling height: 2.7 – 3.5 m)		2	O	
	High ceiling (ceiling height: 3.5 – 4.5 m)		3		
Fan speed during the cooling thermostat is OFF	Setting fan speed	27	1		
	Stop		2		
	Extra low		3	O	

*1 When the power supply returns, the air conditioner will start 3 minutes later.

*2 Power failure automatic recovery initial setting depends on the connecting outdoor unit.

*3 When the 3D i-see Sensor corner panel position is changed, change this mode. Refer to page 18.

7. Test run

7.1. Before test run

- ▶ After completing installation and the wiring and piping of the indoor and outdoor units, check for refrigerant leakage, looseness in the power supply or control wiring, wrong polarity, and no disconnection of one phase in the supply.
- ▶ Use a 500-volt megohmmeter to check that the resistance between the power supply terminals and ground is at least 1.0 MΩ.

- ▶ Do not carry out this test on the control wiring (low voltage circuit) terminals.
- ⚠ **Warning:**
Do not use the air conditioner if the insulation resistance is less than 1.0 MΩ.

7.2. Test run

7.2.1. Using wired remote controller.

- Make sure to read operation manual before test run. (Especially items to secure safety)

Step 1 Turn on the power.

- Remote controller: The system will go into startup mode, and the remote controller power lamp (green) and "PLEASE WAIT" will blink. While the lamp and message are blinking, the remote controller cannot be operated. Wait until "PLEASE WAIT" is not displayed before operating the remote controller. After the power is turned on, "PLEASE WAIT" will be displayed for approximately 2 minutes.
 - Indoor controller board: LED 1 will be lit up, LED 2 will be lit up (if the address is 0) or off (if the address is not 0), and LED 3 will blink.
 - Outdoor controller board: LED 1 (green) and LED 2 (red) will be lit up. (After the startup mode of the system finishes, LED 2 will be turned off.) If the outdoor controller board uses a digital display, [-] and [-] will be displayed alternately every second.
- If the operations do not function correctly after the procedures in step 2 and thereafter are performed, the following causes should be considered and eliminated if they are found.

(The symptoms below occur during the test run mode. "Startup" in the table means the LED display written above.)

Symptoms in test run mode		Cause
Remote Controller Display	OUTDOOR BOARD LED Display < > indicates digital display.	
Remote controller displays "PLEASE WAIT", and cannot be operated.	After "startup" is displayed, only green lights up. <00>	• After power is turned on, "PLEASE WAIT" is displayed for 2 minutes during system startup. (Normal)
After power is turned on, "PLEASE WAIT" is displayed for 3 minutes, then error code is displayed.	After "startup" is displayed, green(once) and red(once) blink alternately. <F1>	• Incorrect connection of outdoor terminal block (R, S, T and S ₁ , S ₂ , S ₃ .)
	After "startup" is displayed, green(once) and red(twice) blink alternately. <F3, F5, F9>	• Outdoor unit's protection device connector is open.
No display appears even when remote controller operation switch is turned on. (Operation lamp does not light up.)	After "startup" is displayed, green(twice) and red(once) blink alternately. <EA, Eb>	• Incorrect wiring between the indoor and outdoor unit (Polarity is wrong for S ₁ , S ₂ , S ₃ .)
	After "startup" is displayed, only green lights up. <00>	• Remote controller transmission wire short.
Display appears but soon disappears even when remote controller is operated.	After "startup" is displayed, only green lights up. <00>	• There is no outdoor unit of address 0. (Address is other than 0.)
	After "startup" is displayed, only green lights up. <00>	• Remote controller transmission wire open.
	After "startup" is displayed, only green lights up. <00>	• After canceling function selection, operation is not possible for about 30 seconds. (Normal)

Step 2 Switch the remote controller to "Test run".

- ① Select "Test run" from the Service menu, and press the [SELECT] button. (Fig. 7-1)
- ② Select "Test run" from the Test run menu, and press the [SELECT] button. (Fig. 7-2)
- ③ The test run operation starts, and the Test run operation screen is displayed.

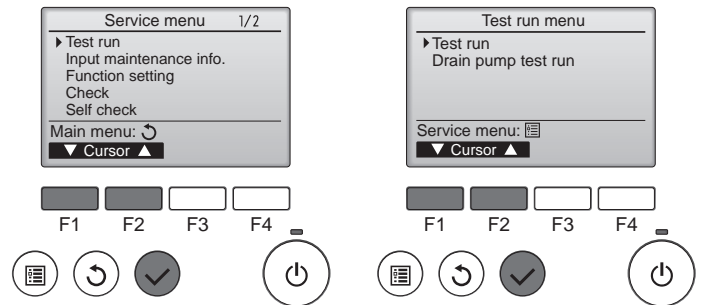

Fig. 7-1

Fig. 7-2

Step 3 Perform the test run and check the airflow temperature and auto vane.

- ① Press the [F1] button to change the operation mode. (Fig. 7-3)
Cooling mode: Check that cool air blows from the unit.
Heating mode: Check that warm air blows from the unit.
- ② Press the [SELECT] button to display the Vane operation screen, and then press the [F1] and [F2] buttons to check the auto vane. (Fig. 7-4)
Press the [RETURN] button to return to the Test run operation screen.

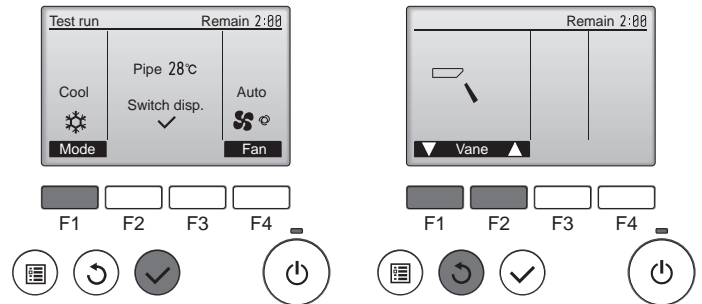

Fig. 7-3

Fig. 7-4

7. Test run

Step 4 Confirm the operation of the outdoor unit fan.

The speed of the outdoor unit fan is controlled in order to control the performance of the unit. Depending on the ambient air, the fan will rotate at a slow speed and will keep rotating at that speed unless the performance is insufficient. Therefore, the outdoor wind may cause the fan to stop rotating or to rotate in the opposite direction, but this is not a problem.

Step 5 Stop the test run.

① Press the [ON/OFF] button to stop the test run. (The Test run menu will appear.)

Note: If an error is displayed on the remote controller, see the table below.

LCD	Description of malfunction	LCD	Description of malfunction	LCD	Description of malfunction
P1	Intake sensor error	P9	Pipe sensor error (dual-wall pipe)	E0 – E5	Communication error between the remote controller and the indoor unit
P2	Pipe sensor error (liquid pipe)	PA	Leakage error (refrigerant system)		
P4	Drain float switch connector disconnected (CN4F)	Pb	Indoor unit fan motor error		
P5	Drain overflow protection operation	PL	Refrigerant circuit abnormal	E6 – EF	Communication error between the indoor unit and the outdoor unit
P6	Freezing/overheating protection operation	FB	Indoor controller board error		
P8	Pipe temperature error	U*, F* (* indicates an alphanumeric character excluding FB.)	Outdoor unit malfunction Refer to the wiring diagram for the outdoor unit.		

See the table below for the details of the LED display (LED 1, 2, and 3) on the indoor controller board.

LED1 (microcomputer power supply)	Indicates whether control power is supplied. Make sure that this LED is always lit.
LED2 (remote controller power supply)	Indicates whether power is supplied to the wired remote controller. The LED is lit only for the indoor unit that is connected to the outdoor unit that has an address of 0.
LED3 (indoor/outdoor unit communication)	Indicates whether the indoor and outdoor units are communicating. Make sure that this LED is always blinking.

7.3. Self-check

■ Refer to the installation manual that comes with each remote controller for details.

• Refer to the following tables for details on the check codes. (Wireless remote controller)

[Output pattern A]

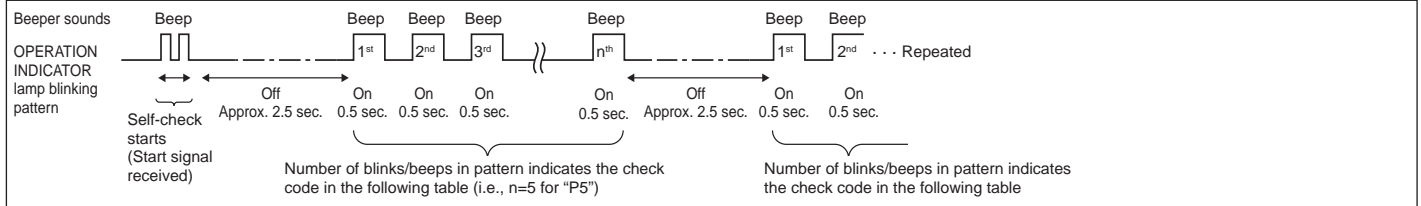

[Output pattern B]

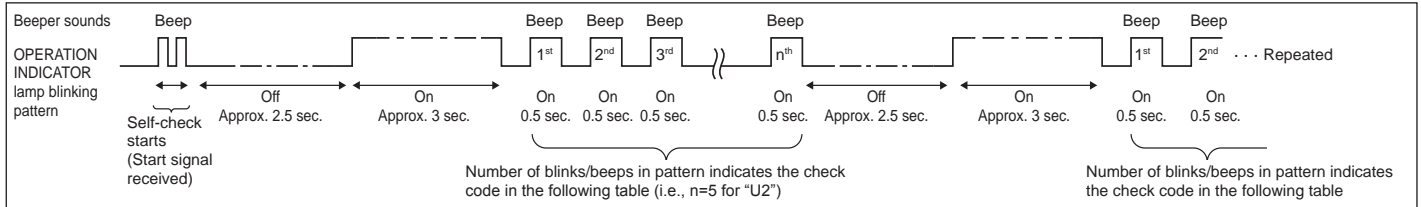

7. Test run

[Output pattern A] Errors detected by indoor unit

Wireless remote controller	Wired remote controller	Symptom	Remark
Beeper sounds/OPERATION INDICATOR lamp blinks (Number of times)	Check code		
1	P1	Intake sensor error	
2	P2	Pipe (TH2) sensor error	
	P9	Pipe (TH5) sensor error	
3	E6, E7	Indoor/outdoor unit communication error	
4	P4	Drain sensor error / Float switch connector open	
5	P5	Drain pump error	
	PA	Forced compressor error	
6	P6	Freezing/Overheating protection operation	
7	EE	Communication error between indoor and outdoor units	
8	P8	Pipe temperature error	
9	E4	Remote controller signal receiving error	
10	—	—	
11	Pb	Indoor unit fan motor error	
12	Fb	Indoor unit control system error (memory error, etc.)	
14	PL	Refrigerant circuit abnormal	
No sound	E0, E3	Remote controller transmission error	
No sound	E1, E2	Remote controller control board error	
No sound	— — — —	No corresponding	

[Output pattern B] Errors detected by unit other than indoor unit (outdoor unit, etc.)

Wireless remote controller	Wired remote controller	Symptom	Remark
Beeper sounds/OPERATION INDICATOR lamp blinks (Number of times)	Check code		
1	E9	Indoor/outdoor unit communication error (Transmitting error) (Outdoor unit)	For details, check the LED display of the outdoor controller board.
2	UP	Compressor overcurrent interruption	
3	U3, U4	Open/short of outdoor unit thermistors	
4	UF	Compressor overcurrent interruption (When compressor locked)	
5	U2	Abnormal high discharging temperature/49C worked/insufficient refrigerant	
6	U1, Ud	Abnormal high pressure (63H worked)/Overheating protection operation	
7	U5	Abnormal temperature of heat sink	
8	U8	Outdoor unit fan protection stop	
9	U6	Compressor overcurrent interruption/Abnormal of power module	
10	U7	Abnormality of super heat due to low discharge temperature	
11	U9, UH	Abnormality such as overvoltage or voltage shortage and abnormal synchronous signal to main circuit/Current sensor error	
12	—	—	
13	—	—	
14	Others	Other errors (Refer to the technical manual for the outdoor unit.)	

*1 If the beeper does not sound again after the initial 2 beeps to confirm the self-check start signal was received and the OPERATION INDICATOR lamp does not come on, there are no error records.

2 If the beeper sounds 3 times continuously "beep, beep, beep (0.4 + 0.4 + 0.4 sec.)" after the initial 2 beeps to confirm the self-check start signal was received, the specified refrigerant address is incorrect.

- On wireless remote controller
The continuous buzzer sounds from receiving section of indoor unit.
Blink of operation lamp
- On wired remote controller
Check code displayed in the LCD.

7. Test run

- If the unit cannot be operated properly after test run, refer to the following table to find the cause.

Symptom		LED 1, 2 (PCB in outdoor unit)	Cause
Wired remote controller			
PLEASE WAIT	For about 2 minutes after power-on	After LED 1, 2 are lighted, LED 2 is turned off, then only LED 1 is lighted. (Correct operation)	• For about 2 minutes after power-on, operation of the remote controller is not possible due to system start-up. (Correct operation)
PLEASE WAIT → Error code	Subsequent to about 2 minutes after power-on	Only LED 1 is lighted. → LED 1, 2 blink.	• Connector for the outdoor unit's protection device is not connected. Reverse or open phase wiring for the outdoor unit's power terminal block (L1, L2, L3)
Display messages do not appear even when operation switch is turned ON (operation lamp does not light up).		Only LED 1 is lighted. → LED 1 blinks twice, LED 2 blinks once.	• Incorrect wiring between indoor and outdoor units (incorrect polarity of S1, S2, S3) • Remote controller wire short

On the wireless remote controller with condition above, following phenomena take place.

- No signals from the remote controller are accepted.
- Operation lamp is blinking.
- The buzzer makes a short ping sound.

Note:

Operation is not possible for about 30 seconds after cancellation of function selection. (Correct operation)

For description of each LED (LED1, 2, 3) provided on the indoor controller, refer to page 14.

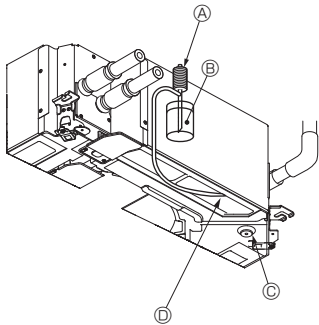

- Ⓐ Water supply pump
 - Ⓑ Water (about 1000 cc)
 - Ⓒ Drain plug
 - Ⓓ Pour water through outlet
- Be careful not to spray water into the drain pump mechanism.

Fig. 7-5

7.4. Check of drainage (Fig. 7-5)

- Ensure that the water is being properly drained out and that no water is leaking from joints.

When electric work is completed.

- Pour water during cooling operation of test run (refer to 7-2.) and check.

When electric work is not completed.

- Pour water during emergency operation and check.

* Drain pan and fan are activated simultaneously when single phase 220-240 V is turned on to S1 and S2 on terminal block after the connector (SWE) on controller board in the electrical box is set to ON.

Be sure to turn it back to the former state after work.

8. System control

Refer to the outdoor unit installation manual.

9. Installing the grille

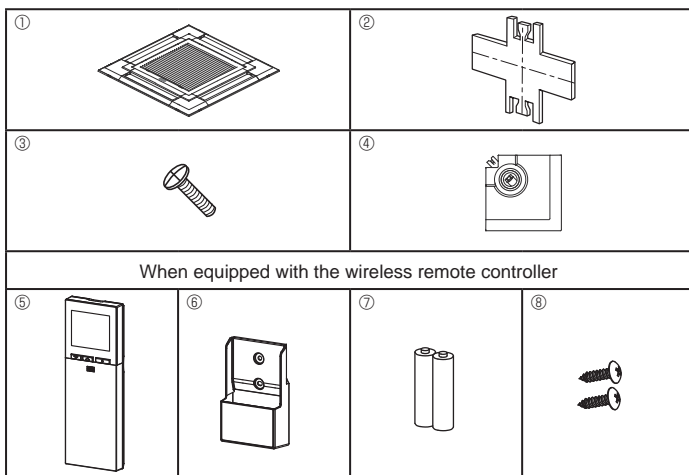

Fig. 9-1

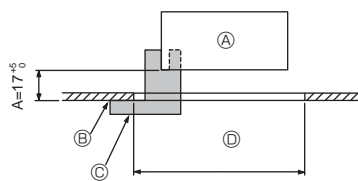

Fig. 9-2

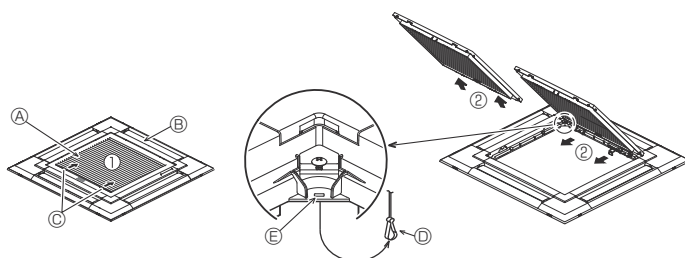

Fig. 9-3

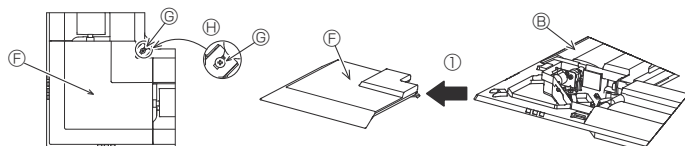

Fig. 9-4

	4-directional	3-directional
Blowout direction patterns	1 pattern: initial setting 	4 patterns: one air outlet fully closed
Blowout direction patterns	2-directional	
Blowout direction patterns	6 patterns: 2 air outlet fully closed 	

Table 1

<Hook is in the raised position>

<Hook is in the lowered position>



Fig. 9-5

9.1. Checking the contents (Fig. 9-1)

This kit contains this manual and the following parts.

	Accessory name	Q'ty	Remarks
①	Grille	1	950 x 950 (mm)
②	Installation gauge	1	(Divided into 4 parts)
③	Screw (4 x 16)	1	For PLP-6EAE, PLP-6EALME, PLP-6EALME
④	i-see Sensor corner panel	1	For PLP-6EAE, PLP-6EALME, PLP-6EALME
⑤	Wireless remote controller	1	For PLP-6EALM, PLP-6EALME
⑥	Remote controller holder	1	Included when equipped with the wireless remote controller.
⑦	LR6 AA batteries	2	Included when equipped with the wireless remote controller.
⑧	3.5 x 16 tapping screws	2	Included when equipped with the wireless remote controller.

9.2. Preparing to attach the grille (Fig. 9-2)

- With the gauge ② supplied with this kit, adjust and check the positioning of the main unit relative to the ceiling surface. If the main unit is not properly positioned relative to the ceiling surface, it may allow air leaks or cause condensation to collect.
- Make sure that the opening in the ceiling is within the following tolerances: 860 x 860 - 910 x 910
- Make sure that A is performed within 17 - 22 mm. Damage could result by failing to adhere to this range.
 - Ⓐ Main unit
 - Ⓑ Ceiling surface
 - Ⓒ Installation gauge ② (inserted into the main unit)
 - Ⓓ Ceiling opening dimensions

9.2.1. Removing the intake grille (Fig. 9-3)

- Slide the levers in the direction indicated by the arrows ① to open the intake grille.
- Unlatch the hook that secures the grille.
 - * Do not unlatch the hook for the intake grille.
- With the intake grille in the "open" position, remove the hinge of the intake grille from the grille as indicated by the arrows ②.

9.2.2. Removing the corner panel (Fig. 9-4)

- Loose the 4 screws on the corner. Slide the corner panel in the direction of the arrow ① in the figure and remove the corner panel.

[Fig. 9-3] [Fig. 9-4]

- Ⓐ Intake grille
- Ⓑ Grille ①
- Ⓒ Intake grille levers
- Ⓓ Grille hook
- Ⓔ Hole for the grille's hook
- Ⓕ Corner panel
- Ⓖ Screw
- Ⓗ Detail

9.3. Selection of air outlets

For this grille the discharge direction is available in 11 patterns. Also, by setting the remote controller to the appropriate settings, you can adjust the air-flow and speed. Select the required settings from the Table 1 according to the location in which you want to install the unit. (More than two directions must be selected.)

- Decide on the discharge direction pattern.
- Be sure to set the remote controller to the appropriate settings according to the number of air outlets and the height of the ceiling on which the main unit will be installed. (Refer to page 12.)

Note:

- When changing the number of directions, you need an air outlet shutter plate, which is optional part.
- Do not select 2 directions in a hot and humid environment. (Dew formation or dew drop may result.)

9.4. Installing the grille

9.4.1. Preparations (Fig. 9-5)

Make sure to flip 2 hooks on the grille up.

9. Installing the grille

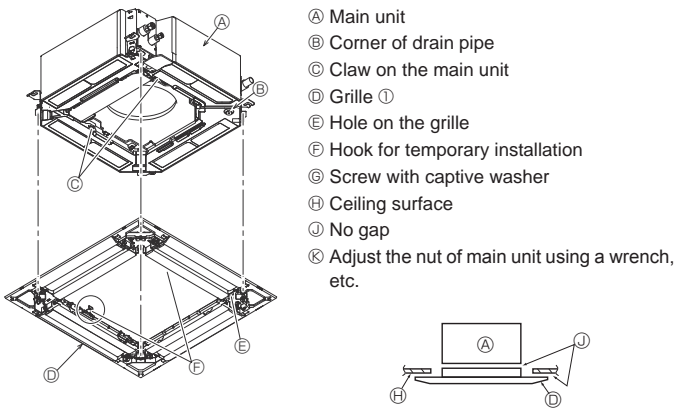

Fig. 9-6

< The grille temporary installed >

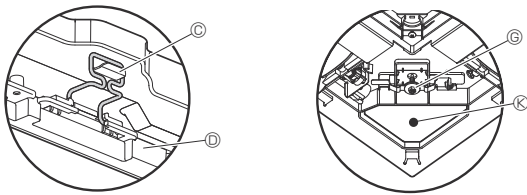

Fig. 9-7

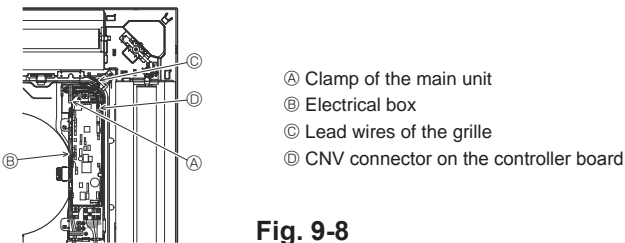

Fig. 9-8

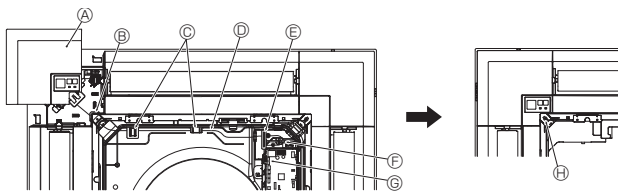

Fig. 9-9

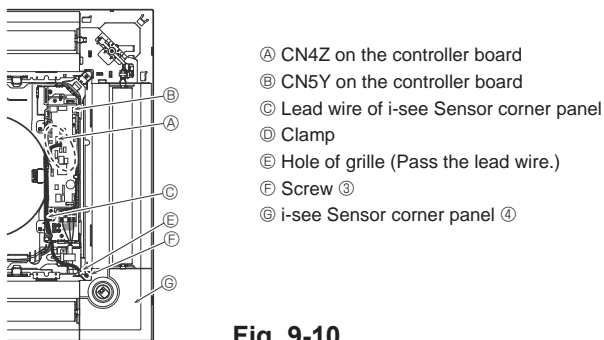

Fig. 9-10

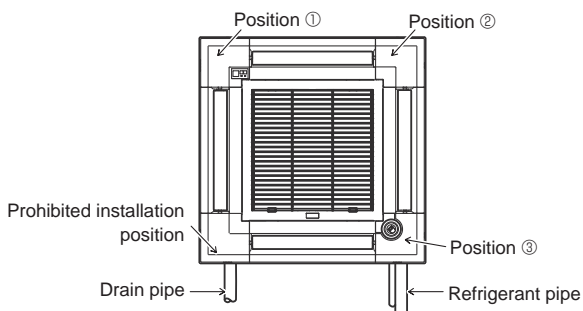

Fig. 9-11

9.4.2. Temporary installation of the grille (Fig. 9-6)

- Join the corner of drain pipe on the main unit with the corner with hole on the grille and put them together temporarily by hanging the hook of the grille to the claw of the main unit.

9.4.3. Fixing the grille

- By tightening the pre-installed screws, fix the grille onto the main unit. (Fig. 9-6)
Note:
Make sure there is no gap between the main unit and the grille or between the grille and the ceiling surface. (Fig. 9-6)

If there is a gap between the grille and the ceiling:

With the grille attached, slightly adjust the installation height of the main unit and clear the gap.

⚠ Caution:

- When tightening the screw, make sure that the tightening torque is 2.8 N·m to 3.6 N·m. Never use an impact screw driver.
- After tightening the screw, confirm that the two grille hooks (Fig. 9-6) are latched onto the hooks on the main unit.

9.4.4. Wire connection (Fig. 9-8)

- Loose the 2 screws fixing the electrical box cover on the main unit, and slide the cover to open.
- Route the lead wire from side of the electrical box.
- Make sure to connect a connector for vane motor (white, 20 poles) to CNV connector (white) on the controller board of the main unit.
- Lead wires that lead off the grille must be held together without slack using a clamp into the electrical box.

9.4.5. Installing signal receiver (Fig. 9-9)

- Route the lead wire (white, 9 poles) for signal receiver corner panel from the side of the electrical box on the main unit.
- Make sure to connect to CN90 (white) on the controller board.
- Make sure that the lead wire of the signal receiver corner panel is passed through the claw of bellmouth.
- The remaining lead wire must be held together without slack using a clamp into the electrical box.
- Put the cover back on the electrical box with 2 screws.

Note:

Make sure wires are not caught in the electrical box cover.

Install the signal receiver corner panel to the panel and fix with the screw.

The signal receiver corner panel can not be installed on the drain pipe side for the main unit. (Refer to Fig. 9-11)

- A Signal receiver corner panel
- B Hole of grille (Pass the lead wire.)
- C Claw of bell mouth
- D Wire
- E Clamp
- F Cable band (Secure the lead wire.)
- G CN90 on controller board
- H Screw

9.4.6. Installation of i-see Sensor corner panel (Fig. 9-10)

- Route the lead wire from the side of electrical box.
- Route the lead wire connector (white, 4 poles and white, 5 poles) of the i-see Sensor corner panel (4) from the side of the electrical box on the main unit and connect to the connector CN4Z and CN5Y on the controller board.
- The remaining lead wire of i-see Sensor corner panel must be held together without slack using the clamp into the electrical box.
- Put the cover back on the electrical box with 2 screws.

Note:

Make sure wires are not caught in the electrical box cover.

- The i-see Sensor corner panel should be fixed onto the grille (1) with screw (3).
- * If the position of the i-see Sensor was changed from default position (position 1) to the other position, change the function settings. (Refer to page 12 and Fig. 9-11)
- The i-see Sensor corner panel can not be installed on the drain pipe side for the main unit. (Refer to Fig. 9-11)

Position 1: Default signal receiver position (Air outlet identification marks □/□□□)

Position 2: (Air outlet identification marks □/□)

Position 3: Default i-see Sensor position (Air outlet identification marks □□/□□)

9. Installing the grille

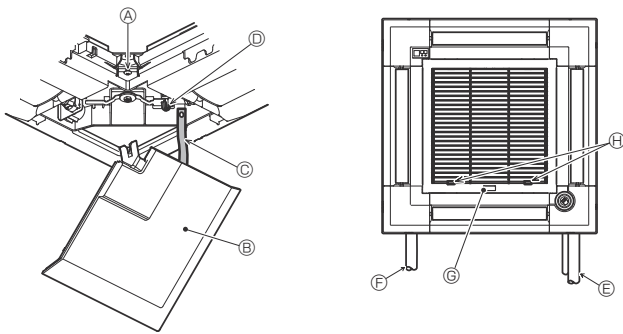

Fig. 9-12

9.5. Installing the intake grille (Fig. 9-12)

Note:

When reinstalling the corner panels (each with a safety strap attached), connect the other end of each safety strap to the grille as shown in the illustration.

* If the corner panels are not attached surely, they may fall off while the main unit is operating.

• Perform the procedure that is described in "9.2. Preparing to attach the grille" in reverse order to install the intake grille and the corner panel.

• The direction of the intake grille can be changed according to the wishes of the customer.

Ⓐ Screw (4 x 16)

Ⓑ Corner panel

Ⓒ Safety strap

Ⓓ Hook

Ⓔ Refrigerant pipe

Ⓕ Drain pipe

Ⓖ Company logo

* Installation in any position is possible.

Ⓔ Initial position of the levers on the intake grille

* Although the clips can be installed in any of 4 positions, the configuration shown here is recommended. (It is not necessary to remove the intake grille when maintenance is performed on the electrical box of the main unit.)

10. Easy maintenance function

Maintenance data, such as the indoor/outdoor unit's heat exchanger temperature and compressor operation current can be displayed with "Smooth maintenance".

* This cannot be executed during test operation.

* Depending on the combination with the outdoor unit, this may not be supported by some models.

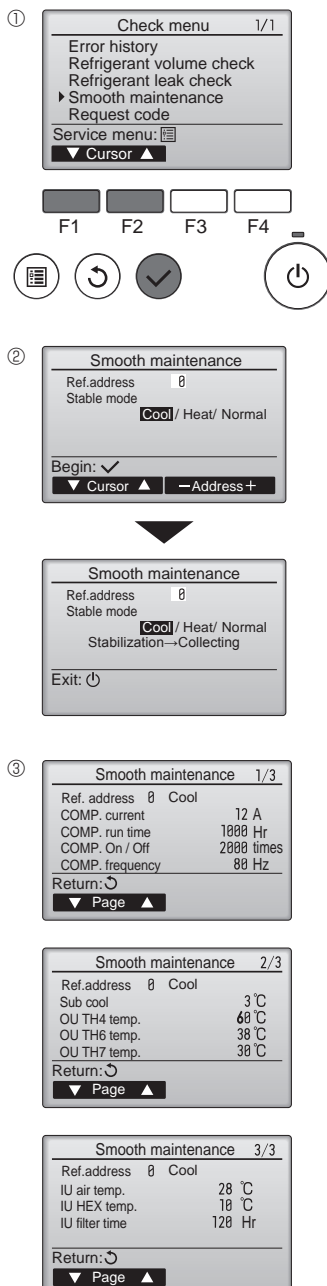

• Select "Service" from the Main menu, and press the [SELECT] button.

• Select "Check" with the [F1] or [F2] button, and press the [SELECT] button.

• Select "Smooth maintenance" with the [F1] or [F2] button, and press the [SELECT] button.

Select each item.

• Select the item to be changed with the [F1] or [F2] button.

• Select the required setting with the [F3] or [F4] button.

"Ref. address" setting "0" - "15"

"Stable mode" setting..... "Cool" / "Heat" / "Normal"

• Press the [SELECT] button, fixed operation will start.

* Stable mode will take approx. 20 minutes.

The operation data will appear.

The Compressor-Accumulated operating (COMP. run) time is 10-hour unit, and the Compressor-Number of operation times (COMP. On/Off) is a 100-time unit (fractions discarded)

Navigating through the screens

- To go back to the Main menu.....[MENU] button
- To return to the previous screen [RETURN] button

This product is designed and intended for use in the residential,
commercial and light-industrial environment.

Please be sure to put the contact address/telephone number on
this manual before handing it to the customer.
Не забудьте указать контактный адрес/номер телефона в данном
руководстве, прежде чем передать его клиенту.

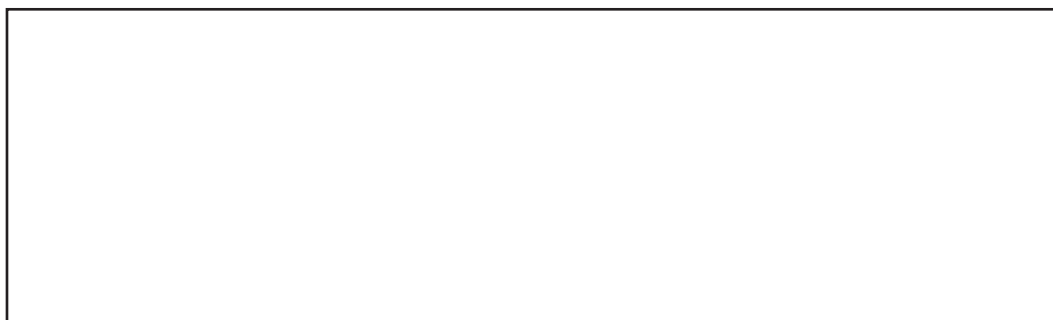

MITSUBISHI ELECTRIC CORPORATION

HEAD OFFICE: TOKYO BUILDING, 2-7-3, MARUNOUCHI, CHIYODA-KU, TOKYO 100-8310, JAPAN

Название Компании: ООО «Мицубиси Электрик (РУС)»

Адрес: россия, 115054, Москва, Космодамианская наб., д. 52, стр. 1