

# Air-Conditioners

## SUZ-KA25, KA35, KA50, KA60, KA71VA6

### INSTALLATION MANUAL

For safe and correct use, read this manual and the indoor unit installation manual thoroughly before installing the air-conditioner unit.

**FOR INSTALLER**

### INSTALLATIONSHANDBUCH

Aus Sicherheitsgründen und zur richtigen Verwendung vor der Installation die vorliegende Bedienungsanleitung und die Installationsanleitung der Innenanlage gründlich durchlesen die Klimaanlage.

**FÜR INSTALLATEURE**

### MANUEL D'INSTALLATION

Avant d'installer le climatiseur, lire attentivement ce manuel, ainsi que le manuel d'installation de l'appareil intérieur pour une utilisation sûre et correcte.

**POUR L'INSTALLATEUR**

### INSTALLATIEHANDLEIDING

Lees deze handleiding en de installatiehandleiding van het binnenapparaat zorgvuldig door voordat u met het installeren van de airconditioner begint.

**VOOR DE INSTALLATEUR**

### MANUAL DE INSTALACIÓN

Para un uso correcto y seguro, lea detalladamente este manual y el manual de instalación de la unidad interior antes de instalar la unidad de aire acondicionado.

**PARA EL INSTALADOR**

### MANUALE DI INSTALLAZIONE

Per un uso sicuro e corretto, leggere attentamente il presente manuale ed il manuale d'installazione dell'unità interna prima di installare il condizionatore d'aria.

**PER L'INSTALLATORE**

### ΕΓΧΕΙΡΙΔΙΟ ΟΔΗΓΙΩΝ ΕΓΚΑΤΑΣΤΑΣΗΣ

Για σωστή και ασφαλή χρήση, διαβάστε προσεκτικά αυτό το εγχειρίδιο καθώς και το εγχειρίδιο εγκατάστασης της εσωτερικής μονάδας, προτού εγκαταστήσετε τη μονάδα του κλιματιστικού.

**ΓΙΑ ΑΥΤΟΝ ΠΟΥ ΚΑΝΕΙ ΤΗΝ ΕΓΚΑΤΑΣΤΑΣΗ**

### MANUAL DE INSTALAÇÃO

Para uma utilização segura e correcta, leia atentamente este manual e o manual de instalação da unidade interior antes de instalar o aparelho de ar condicionado.

**PARA O INSTALADOR**

### INSTALLATIONSMANUAL

Læs af sikkerhedshensyn denne manual samt manualen til installation af indendørsenheden grundigt, før du installerer klimaanlægget.

**TIL INSTALLATØREN**

### INSTALLATIONSMANUAL

Läs bruksanvisningen och inomhusenhetens installationshandbok noga innan luftkonditioneringen installeras så att den används på ett säkert och korrekt sätt.

**FÖR INSTALLATÖREN**

### MONTAJ ELKİTABI

Emniyetli ve doğru kullanım için, klima cihazını monte etmeden önce bu kılavuzu ve iç ünite montaj kılavuzunu tamamiyla okuyun.

**MONTÖR İÇİN**

### INSTALLASJONSHÅNDBOK

For å sikre trygg og riktig bruk skal denne håndboken samt installasjonshåndboken for innendørsenheten leses grundig gjennom før du installerer klimaanleggenheten.

**FOR MONTØR**

### INSTRUKCJA MONTAŻU

Aby zapewnić bezpieczne i prawidłowe korzystanie z urządzenia, przed montażem klimatyzatora należy dokładnie zapoznać się z treścią niniejszej instrukcji oraz instrukcji montażu jednostki wewnętrznej.

**DLA INSTALATORA**

English

Deutsch

Français

Nederlands

Español

Italiano

Ελληνικά

Português

Dansk

Svenska

Türkçe

Norsk

Polski

# Contents

1. The following should always be observed for safety	2	6. Electrical work	6
2. Selecting the installation location	2	7. Maintenance	7
3. Installation diagram	3	8. Pumping down	8
4. Drain piping for outdoor unit	3	9. Specifications	8
5. Refrigerant piping work	4		

## 1. The following should always be observed for safety

- Please provide an exclusive circuit for the air conditioner and do not connect other electrical appliances to it.
- Be sure to read “The following should always be observed for safety” before installing the air conditioner.
- Be sure to observe the cautions specified here as they include important items related to safety.
- The indications and meanings are as follows.

**⚠ Warning:**  
Could lead to death, serious injury, etc.

**⚠ Caution:**  
Could lead to serious injury in particular environments when operated incorrectly.

- ⚠ Warning:**
- Do not install it by yourself (customer). Incomplete installation could cause injury due to fire, electric shock, the unit falling or leakage of water. Consult the dealer from whom you purchased the unit or special installer.
  - This appliance is intended to be used by expert or trained users in shops, in light industry and on farms, or for commercial use by lay persons.
  - Install the unit securely in a place which can bear the weight of the unit. When installed in an insufficient strong place, the unit could fall causing injured.
  - Use the specified wires to connect the indoor and outdoor units securely and attach the wires firmly to the terminal board connecting sections so the stress of the wires is not applied to the sections. Incomplete connecting and fixing could cause fire.
  - Do not use intermediate connection of the power cord or the extension cord and do not connect many devices to one AC outlet. It could cause a fire or an electric shock due to defective contact, defective insulation, exceeding the permissible current, etc.
  - Check that the refrigerant gas does not leak after installation has completed.
  - Perform the installation securely referring to the installation manual. Incomplete installation could cause a personal injury due to fire, electric shock, the unit falling or leakage of water.
  - Use only specified cables for wiring. The wiring connections must be made securely with no tension applied on the terminal connections. Also, never splice the cables for wiring (unless otherwise indicated in this document). Failure to observe these instructions may result in overheating or a fire.
  - Perform electrical work according to the installation manual and be sure to use an exclusive circuit.

- ⚠ Caution:**
- Perform grounding. Do not connect the ground wire to a gas pipe, water pipe arrester or telephone ground wire. Defective grounding could cause an electric shock.
  - Do not install the unit in a place where an inflammable gas leaks. If gas leaks and accumulates in the area surrounding the unit, it could cause an explosion.
  - Install a ground leakage breaker depending on the installation place (where it is humid).

- After reading this manual, be sure to keep it together with the instruction manual in a handy place on the customer’s site.

**⚡** : Indicates a part which must be grounded.

**⚠ Warning:**  
Carefully read the labels affixed to the main unit.

- If the capacity of the power circuit is insufficient or there is incomplete electrical work, it could result in a fire or an electric shock.
- Attach the electrical part cover to the indoor unit and the service panel to the outdoor unit securely. If the electrical part cover in the indoor unit and/or the service panel in the outdoor unit are not attached securely, it could result in a fire or an electric shock due to dust, water, etc.
  - Be sure to use the part provided or specified parts for the installation work. The use of defective parts could cause an injury or leakage of water due to a fire, an electric shock, the unit falling, etc.
  - Ventilate the room if refrigerant leaks during operation. If the refrigerant comes in contact with a flame, poisonous gases will be released.
  - When pumping down the refrigerant, stop the compressor before disconnecting the refrigerant pipes. The compressor may burst if air etc. get into it.
  - When installing or relocating, or servicing the air conditioner, use only the specified refrigerant (R410A) to charge the refrigerant lines. Do not mix it with any other refrigerant and do not allow air to remain in the lines. If air is mixed with the refrigerant, then it can be the cause of abnormal high pressure in the refrigerant line, and may result in an explosion and other hazards. The use of any refrigerant other than that specified for the system will cause mechanical failure or system malfunction or unit breakdown. In the worst case, this could lead to a serious impediment to securing product safety.

- If a ground leakage breaker is not installed, it could cause an electric shock.
- Perform the drainage/piping work securely according to the installation manual. If there is a defect in the drainage/piping work, water could drop from the unit and household goods could be wet and damaged.
  - Fasten a flare nut with a torque wrench as specified in this manual. When fastened too tight, a flare nut may be broken after a long period and cause a leakage of refrigerant.

## 2. Selecting the installation location

### 2.1. Outdoor unit

- Where it is not exposed to strong wind.
- Where airflow is good and dustless.
- Where it is not exposed to rain and direct sunshine.
- Where neighbours are not annoyed by operation sound or hot air.
- Where rigid wall or support is available to prevent the increase of operation sound or vibration.
- Where there is no risk of combustible gas leakage.
- When installing the unit at a high level, be sure to fix the unit legs.
- Where it is at least 3 m away from the antenna of TV set or radio. (Otherwise, images would be disturbed or noise would be generated.)
- Please install it in an area not affected by snowfall or blowing snow. In areas with heavy snow, please install a canopy, a pedestal and/or some baffle boards.
- Install the unit horizontally.

**⚠ Caution:**  
Avoid the following places for installation where air conditioner trouble is liable to occur.

- Where there is too much machine oil.
- Salty environment as seaside areas.
- Hot-spring areas.
- Where sulfide gas exists.
- Other special atmospheric areas.

The outdoor unit produces condensate during the heating operation. Select the installation place to ensure to prevent the outdoor unit and/or the grounds from being wet by drain water or damaged by frozen drain water.

### 3. Installation diagram

■ SUZ-KA25VA6  
SUZ-KA35VA6

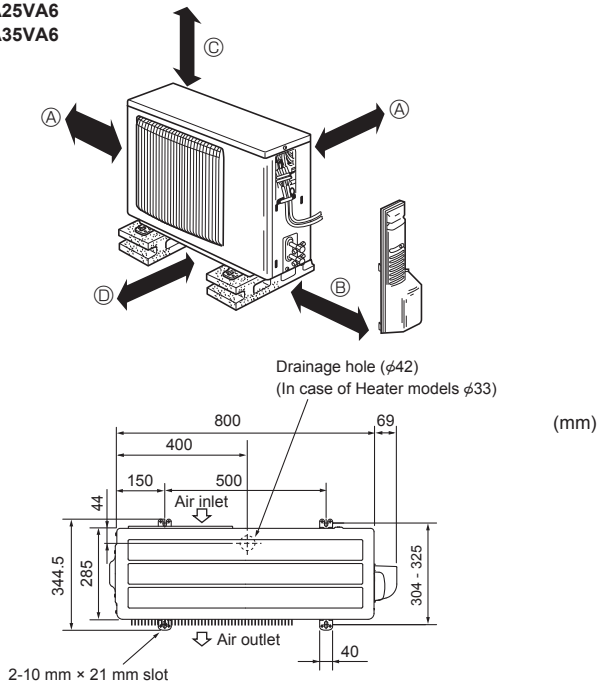

■ SUZ-KA50VA6  
SUZ-KA60VA6  
SUZ-KA71VA6

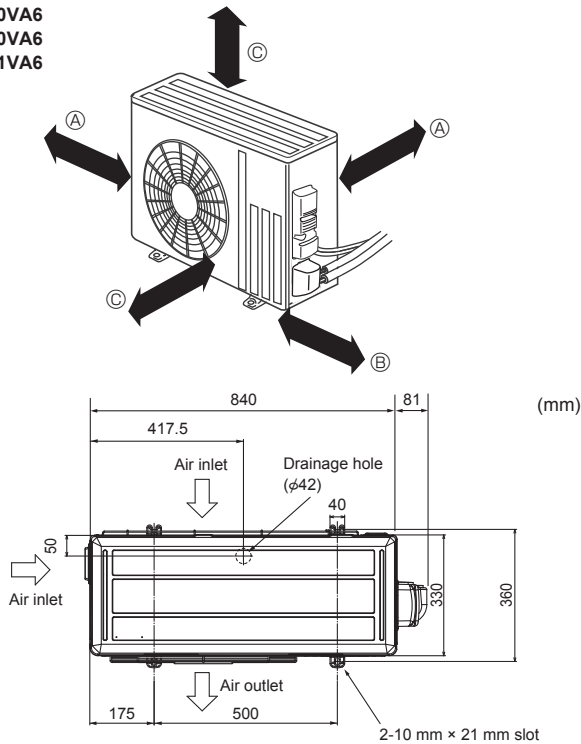

Fig. 3-1

#### 3.1. Outdoor unit (Fig. 3-1)

##### Ventilation and service space

■ SUZ-KA25VA6

SUZ-KA35VA6

Ⓐ 100 mm or more

Ⓑ 350 mm or more

Ⓒ Basically open 100 mm or more without any obstruction in front and on both sides of the unit.

Ⓓ 200 mm or more (Open two sides of left, right, or rear side.)

■ SUZ-KA50VA6

SUZ-KA60VA6

SUZ-KA71VA6

Ⓐ 100 mm or more

Ⓑ 350 mm or more

Ⓒ 500 mm or more

When the piping is to be attached to a wall containing metals (tin plated) or metal netting, use a chemically treated wooden piece 20 mm or thicker between the wall and the piping or wrap 7 to 8 turns of insulation vinyl tape around the piping.

Units should be installed by licensed contractor accordingly to local code requirement.

**Note:**

**When operating the air conditioner in low outside temperature, be sure to follow the instructions described below.**

- Never install the outdoor unit in a place where its air inlet/outlet side may be exposed directly to wind.
- To prevent exposure to wind, install the outdoor unit with its air inlet side facing the wall.
- To prevent exposure to wind, it is recommended to install a baffle board on the air outlet side of the outdoor unit.

### 4. Drain piping for outdoor unit (Fig. 4-1)

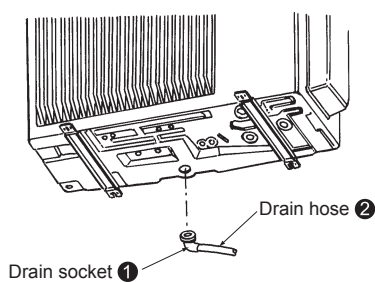

Fig. 4-1

#### 4.1. Accessories

Check the following parts before installation.

<Outdoor unit>

①	Drain socket	1
---	--------------	---

- Provide drain piping before indoor and outdoor piping connection. (It will be hard to install drain socket ① if indoor and outdoor piping connection is conducted prior to drain piping as outdoor unit becomes immovable.)
- Connect the drain hose ② (obtainable at a store, inside diameter: 15 mm) as shown in the figure for drainage.
- Make sure to provide drain piping with a downhill grade for easy drain flow.

**Note:**

**Do not use the drain socket ① in the cold region. Drain may freeze and it makes the fan stop.**

## 5. Refrigerant piping work

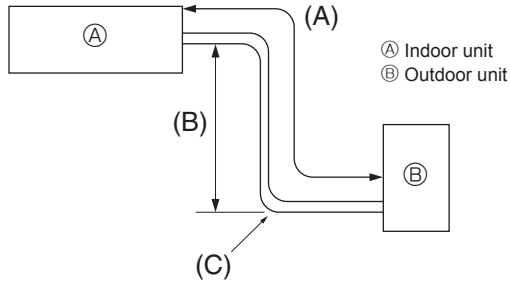

Fig. 5-1

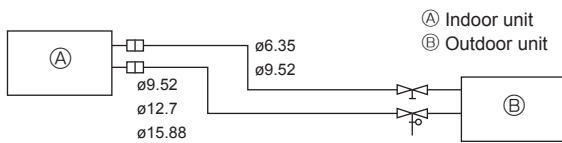

Fig. 5-2

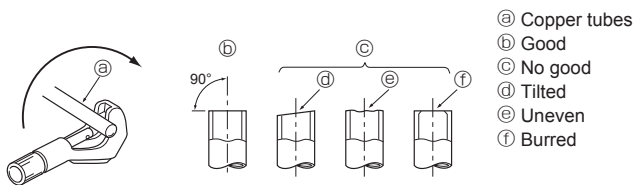

Fig. 5-3

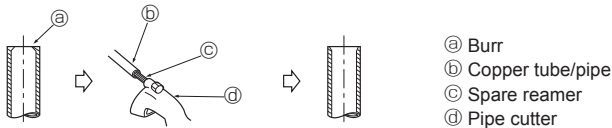

Fig. 5-4

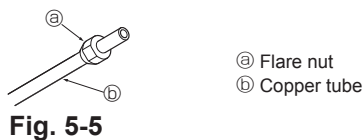

Fig. 5-5

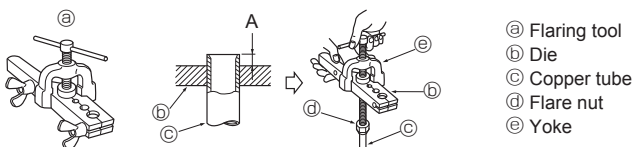

Fig. 5-6

### 5.1. Refrigerant pipe (Fig. 5-1)

► Check that the difference between the heights of the indoor and outdoor units, the length of refrigerant pipe, and the number of bends in the pipe are within the limits shown below.

Models	(A) Pipe length (one way)	(B) Height difference	(C) Number of bends (one way)
SUZ-KA25/KA35	Max. 20 m	Max. 12 m	Max. of 10
SUZ-KA50/KA60/KA71	Max. 30 m	Max. 30 m	Max. of 10

- Height difference limitations are binding regardless of which unit, indoor or outdoor, is positioned higher.
- Refrigerant adjustment ... If pipe length exceeds 7 m, additional refrigerant (R410A) charge is required.  
(The outdoor unit is charged with refrigerant for pipe length up to 7 m.)

Pipe length	Up to 7 m	No additional charge is required.
	Exceeding 7 m	Additional charge is required. (Refer to the table below.)
Refrigerant to be added	SUZ-KA25/KA35 type	30 g × (refrigerant piping length (m) - 7)
	SUZ-KA50/KA60 type	20 g × (refrigerant piping length (m) - 7)
	SUZ-KA71 type	55 g × (refrigerant piping length (m) - 7)

(1) Table below shows the specifications of pipes commercially available.

Model	Pipe	Outside diameter		Min. wall thickness	Insulation thickness	Insulation material
		mm	inch			
SUZ-KA25	For liquid	6.35	1/4	0.8 mm	8 mm	Heat resisting foam plastic 0.045 specific gravity
	For gas	9.52	3/8	0.8 mm	8 mm	
SUZ-KA35	For liquid	6.35	1/4	0.8 mm	8 mm	
	For gas	9.52	3/8	0.8 mm	8 mm	
SUZ-KA50	For liquid	6.35	1/4	0.8 mm	8 mm	
	For gas	12.7	1/2	0.8 mm	8 mm	
SUZ-KA60	For liquid	6.35	1/4	0.8 mm	8 mm	
	For gas	15.88	5/8	0.8 mm	8 mm	
SUZ-KA71	For liquid	9.52	3/8	0.8 mm	8 mm	
	For gas	15.88	5/8	1.0 mm	8 mm	

- (2) Ensure that the 2 refrigerant pipes are well insulated to prevent condensation.  
(3) Refrigerant pipe bending radius must be 100 mm or more.

#### ⚠ Caution:

Using careful insulation of specified thickness. Excessive thickness prevents storage behind the indoor unit and smaller thickness causes dew dripping.

### 5.2. Flaring work

- Main cause of gas leakage is defect in flaring work.  
Carry out correct flaring work in the following procedure.

#### 5.2.1. Pipe cutting (Fig. 5-3)

- Using a pipe cutter cut the copper tube correctly.

#### 5.2.2. Burrs removal (Fig. 5-4)

- Completely remove all burrs from the cut cross section of pipe/tube.  
Put the end of the copper tube/pipe to downward direction as you remove burrs in order to avoid burrs drop in the tubing.

#### 5.2.3. Putting nut on (Fig. 5-5)

- Remove flare nuts attached to indoor and outdoor unit, then put them on pipe/tube having completed burr removal.  
(not possible to put them on after flaring work)

#### 5.2.4. Flaring work (Fig. 5-6)

- Carry out flaring work using flaring tool as shown at the right.

Pipe diameter (mm)	Dimension	
	A (mm)	B <sup>+0</sup> <sub>-0.4</sub> (mm)
	When the tool for R410A is used Clutch type	
6.35	0 - 0.5	9.1
9.52	0 - 0.5	13.2
12.7	0 - 0.5	16.6
15.88	0 - 0.5	19.7

Firmly hold copper tube in a die in the dimension shown in the table at above.

## 5. Refrigerant piping work

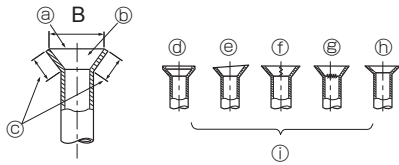

Fig. 5-7

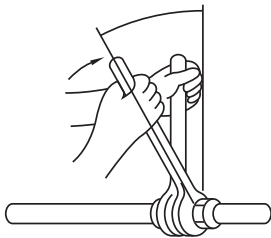

Fig. 5-8

### 5.2.5. Check (Fig. 5-7)

- Compare the flared work with a figure in right side hand.
- If flare is noted to be defective, cut off the flared section and do flaring work again.

- Ⓐ Smooth all around
- Ⓑ Inside is shining without any scratches
- Ⓒ Even length all around
- Ⓓ Too much
- Ⓔ Tilted
- Ⓛ Scratch on flared plane
- Ⓜ Cracked
- Ⓨ Uneven
- Ⓩ Bad examples

- Apply a thin coat of refrigeration oil on the seat surface of pipe. (Fig. 5-8)
- For connection first align the center, then tighten the first 3 to 4 turns of flare nut.
- Use tightening torque table below as a guideline for indoor unit side union joint section, and tighten using two wrenches. Excessive tightening damages the flare section.

Copper pipe O.D. (mm)	Flare nut O.D. (mm)	Tightening torque (N·m)
ø6.35	17	14 - 18
ø9.52	22	34 - 42
ø12.7	26	49 - 61
ø15.88	29	68 - 82

**Warning:**  
When installing the unit, securely connect the refrigerant pipes before starting the compressor.

**Warning:**  
Be careful of flying flare nut! (Internally pressurized)  
Remove the flare nut as follows:

1. Loosen the nut until you hear a hissing noise.
2. Do not remove the nut until the gas has been completely released (i.e., hissing noise stops).
3. Check that the gas has been completely released, and then remove the nut.

## 5.5. Purging procedures leak test

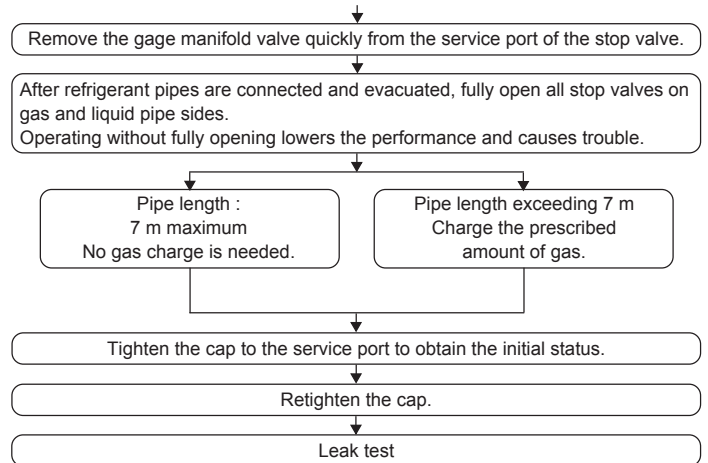
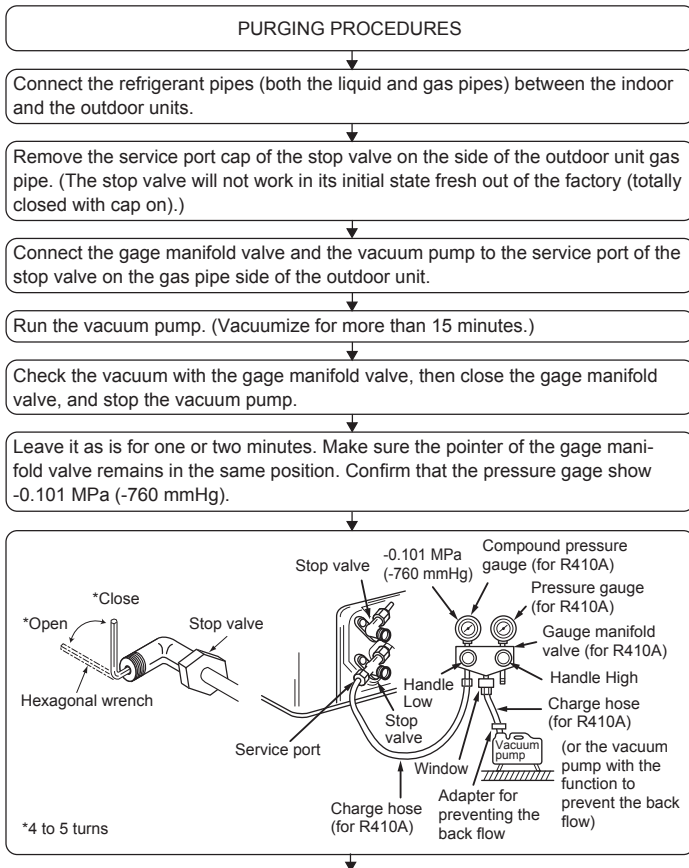

## 6. Electrical work

### 6.1. Outdoor unit (Fig. 6-1, Fig. 6-2, Fig. 6-3, Fig. 6-4)

- ① Remove the service panel.
- ② Wire the cables referring to the Fig. 6-1, Fig. 6-2, Fig. 6-3 and the Fig. 6-4.

#### ■ SUZ-KA25/35/50VA6

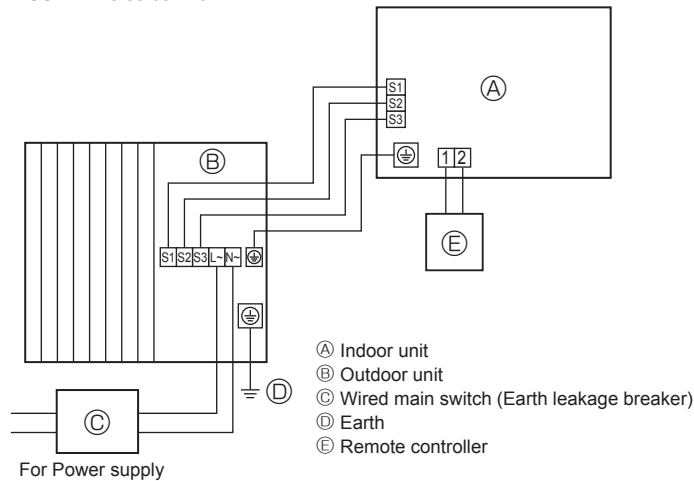

Fig. 6-1

#### ■ SUZ-KA60/71VA6

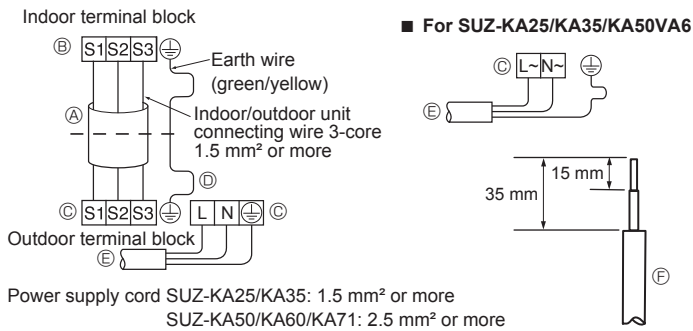
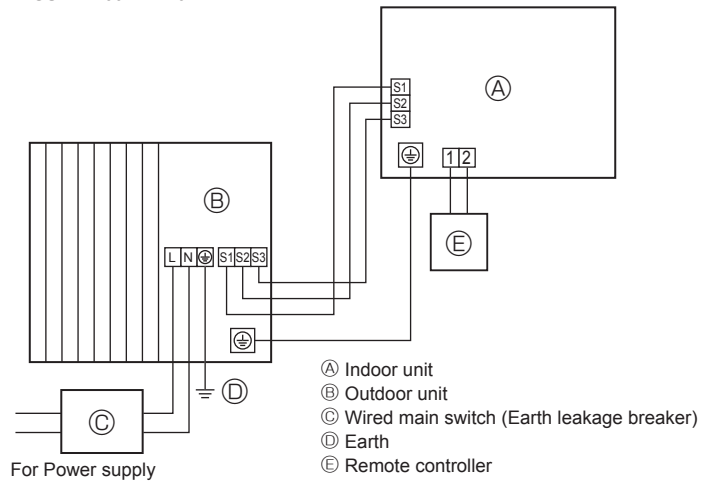

Fig. 6-2

#### ■ SUZ-KA25/35VA6

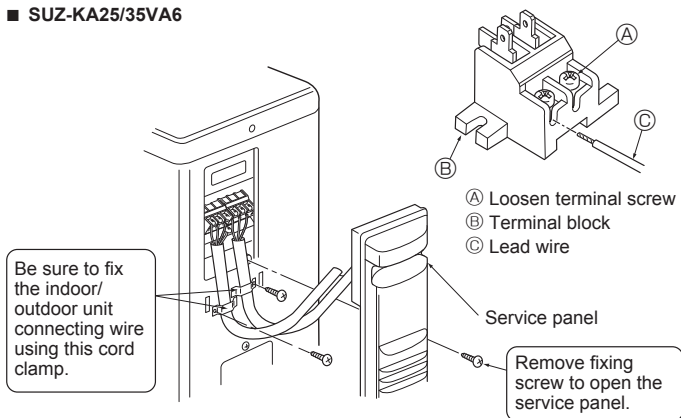

Fig. 6-3

#### ■ SUZ-KA50/60/71VA6

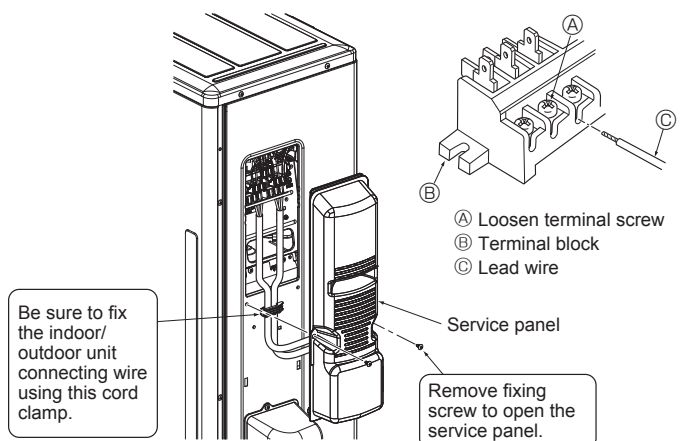

Fig. 6-4

- Perform wiring as shown in the diagram to the lower left. (Procure the cable locally) (Fig. 6-2)

Make sure to use cables of the correct polarity only.

- (A) Connecting cable
- (B) Indoor terminal block
- (C) Outdoor terminal block
- (D) Always install an earth wire longer than other cables.
- (E) Power supply cord
- (F) Lead wire

- Make earth wire a little longer than others. (More than 100 mm)
- For future servicing, give extra length to the connecting wires.
- Be sure to attach each screw to its correspondent terminal when securing the cord and/or the wire to the terminal block.

- Connect cable from the indoor unit correctly on the terminal-block.
- Use the same terminal block and polarity as is used with the indoor unit.
- For aftercare maintenance, give extra length to connecting cable.

- Both end of connecting cable (extension wire) are peeled off. When too long, or connected by cutting off the middle, peel off power supply cable to the size given in the figure.
- Be careful not to contact connecting cable with piping.

#### ⚠ Caution:

- Use care not to make miswiring.
- Firmly tighten the terminal screws to prevent them from loosening.
- After tightening, pull the wires lightly to confirm that they do not move.

#### ⚠ Warning:

- Be sure to attach the service panel of the outdoor unit securely. If it is not attached correctly, it could result in a fire or an electric shock due to dust, water, etc.
- Tighten terminal screws securely.
- Wiring should be done so that the power lines are not subject to tension. Otherwise, heat may be generated or fire may occur.



## 6. Electrical work

### 6.2. Field electrical wiring

Outdoor unit model		SUZ-KA25/KA35	SUZ-KA35 *3	SUZ-KA50/KA60/KA71
Outdoor unit power supply		~N (single), 50 Hz, 230 V	~N (single), 50 Hz, 230 V	~N (single), 50 Hz, 230 V
Outdoor unit input capacity Main switch (Breaker)		*1	10 A	20 A
Wiring Wire No. x size (mm <sup>2</sup> )	Outdoor unit power supply	2 x Min. 1.5	2 x Min. 2.0	2 x Min. 2.5
	Outdoor unit power supply earth	1 x Min. 1.5	1 x Min. 2.0	1 x Min. 2.5
	Indoor unit-Outdoor unit	3 x 1.5 (Polar)	3 x 1.5 (Polar)	3 x 1.5 (Polar)
	Indoor unit-Outdoor unit earth	1 x Min. 1.5	1 x Min. 1.5	1 x Min. 1.5
Circuit rating	Outdoor unit L-N	*2	230 VAC	230 VAC
	Indoor unit-Outdoor unit S1-S2	*2	230 VAC	230 VAC
	Indoor unit-Outdoor unit S2-S3	*2	12 VDC – 24 VDC	12 VDC – 24 VDC

\*1. A breaker with at least 3 mm contact separation in each poles shall be provided. Use earth leakage breaker (NV).

Make sure that the current leakage breaker is one compatible with higher harmonics.

Always use a current leakage breaker that is compatible with higher harmonics as this unit is equipped with an inverter.

The use of an inadequate breaker can cause the incorrect operation of inverter.

\*2. The figures are NOT always against the ground.

S3 terminal has 24 VDC against S2 terminal. However between S3 and S1, these terminals are NOT electrically insulated by the transformer or other device.

\*3. In case of PEAD-RP35JA series combination.

Notes: 1. Wiring size must comply with the applicable local and national code.

2. Power supply cords and Indoor/Outdoor unit connecting cords shall not be lighter than polychloroprene sheathed flexible cord. (Design 60245 IEC 57)

3. Install an earth longer than other cables.

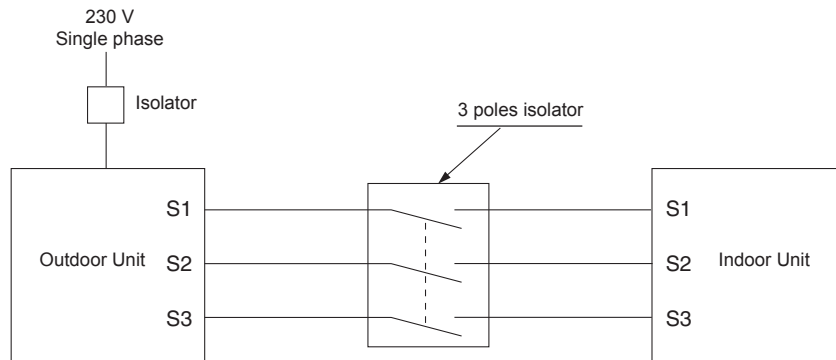

#### ⚠ Warning:

There is high voltage potential on the S3 terminal caused by electrical circuit design that has no electrical insulation between power line and communication signal line. Therefore, please turn off the main power supply when servicing. And do not touch the S1, S2, S3 terminals when the power is energized. If isolator should be used between indoor unit and outdoor unit, please use 3-poles type.

Never splice the power cable or the indoor-outdoor connection cable, otherwise it may result in a smoke, a fire or communication failure.

## 7. Maintenance

### 7.1. Gas charge (Fig. 7-1)

1. Connect gas cylinder to the service port of stop valve (3-way).
2. Execute air purge of the pipe (or hose) coming from refrigerant gas cylinder.
3. Replenish specified amount of refrigerant, while running the air conditioner for cooling.

#### Note:

In case of adding refrigerant, comply with the quantity specified for the refrigerating cycle.

#### ⚠ Caution:

- Do not discharge the refrigerant into the atmosphere. Take care not to discharge refrigerant into the atmosphere during installation, reinstallation, or repairs to the refrigerant circuit.
- For additional charging, charge the refrigerant from liquid phase of the gas cylinder.

If the refrigerant is charged from the gas phase, composition change may occur in the refrigerant inside the cylinder and the outdoor unit. In this case, ability of the refrigerating cycle decreases or normal operation can be impossible. However, charging the liquid refrigerant all at once may cause the compressor to be locked. Thus, charge the refrigerant slowly.

To maintain the high pressure of the gas cylinder, warm the gas cylinder with warm water (under 40°C) during cold season. But never use naked fire or steam.

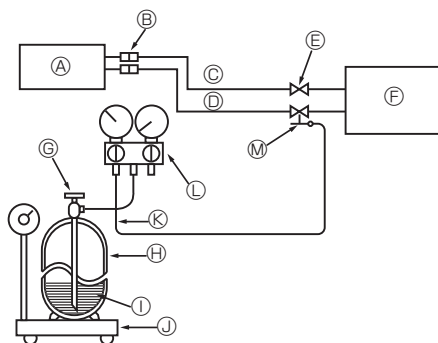

- |  |  |
|--|--|
| (A) Indoor unit                              | (H) Refrigerant gas cylinder for R410A with siphon |
| (B) Union                                    | (I) Refrigerant (liquid)                           |
| (C) Liquid pipe                              | (J) Electronic scale for refrigerant charging      |
| (D) Gas pipe                                 | (K) Charge hose (for R410A)                        |
| (E) Stop valve                               | (L) Gauge manifold valve (for R410A)               |
| (F) Outdoor unit                             | (M) Service port                                   |
| (G) Refrigerant gas cylinder operating valve |  |

Fig. 7-1

## 8. Pumping down

When relocating or disposing of the air conditioner, pump down the system following the procedure below so that no refrigerant is released into the atmosphere.

- ① Turn off the power supply (circuit breaker).
- ② Connect the gauge manifold valve to the service port of the stop valve on the gas pipe side of the outdoor unit.
- ③ Fully close the stop valve on the liquid pipe side of the outdoor unit.
- ④ Supply power (circuit breaker).
- ⑤ Perform the refrigerant collecting operation (cooling test run).
  - For the PAR-31MAA, select "Service" → "TestRun" from the main menu to start the test run, and then select the cooling mode.
  - For details or for other information about starting the test run when using remote controllers, refer to the installation manual for the indoor unit or the remote controller.
- ⑥ Fully close the stop valve on the gas pipe side of the outdoor unit when the pressure gauge shows 0.05 to 0 MPa [Gauge] (approx. 0.5 to 0 kgf/cm<sup>2</sup>) and quickly stop the air conditioner.
  - Push the "ON/OFF" button on the remote controller to stop the air conditioner.
  - \* Note that when the extension piping is very long with a large refrigerant amount, it may not be possible to perform a pump-down operation. In this case, use refrigerant recovery equipment to collect all of the refrigerant in the system.

- ⑦ Turn off the power supply (circuit breaker), remove the gauge manifold valve, and then disconnect the refrigerant pipes.

**⚠ Warning:**

**When pumping down the refrigerant, stop the compressor before disconnecting the refrigerant pipes.**

- **If the refrigerant pipes are disconnected while the compressor is operating and the stop valve (ball valve) is open, the pressure in the refrigeration cycle could become extremely high if air is drawn in, causing the pipes to burst, personal injury, etc.**

## 9. Specifications

Outdoor model		SUZ-KA25VA6.TH	SUZ-KA35VA6.TH	SUZ-KA50VA6.TH	SUZ-KA60VA6.TH	SUZ-KA71VA6.TH
Power supply		Single phase 230 V, 50 Hz				
Dimensions W × H × D		800 × 550 × 285			840 × 880 × 330	
Weight		30	35	54	50	53
Sound level *1	Cooling	47	49	52	55	
	Heating	48	50	52	55	

\*1 Measured under rated operating frequency.



This product is designed and intended for use in the residential, commercial and light-industrial environment.

**Importer:**

Mitsubishi Electric Europe B.V.  
Capronilaan 46, 1119 NS, Schiphol Rijk, The Netherlands

French Branch  
25, Boulevard des Bouvets, 92741 Nanterre Cedex, France

German Branch  
Mitsubishi-Electric-Platz 1, 40882 Ratingen, Germany

Belgian Branch  
Autobaan 2, 8210 Loppem, Belgium

Irish Branch  
Westgate Business Park, Ballymount, Dublin 24, Ireland

Italian Branch  
Centro Direzionale Colleoni, Palazzo Sirio-Ingresso 1 Viale Colleoni 7, 20864 Agrate Brianza (MB), Italy

Norwegian Branch  
Gneisveien 2D, 1914 Ytre Enebakk, Norway

Portuguese Branch  
Avda. do Forte, 10, 2799-514, Carnaxide, Lisbon, Portugal

Spanish Branch  
Carretera de Rubi 76-80 - Apdo. 420 08173 Sant Cugat del Valles (Barcelona), Spain

Scandinavian Branch  
Hammarbacken 14, P.O. Box 750 SE-19127, Sollentuna, Sweden

UK Branch  
Travellers Lane, Hatfield, Herts., AL10 8XB, England, U.K.

Polish Branch  
Krakowska 50, PL-32-083 Balice, Poland

mitsubishi electric turkey elektrik ürünleri a.ş.  
Şerifali Mah. Kale Sok. No: 41 34775 Ümraniye, İstanbul / Turkey

MITSUBISHI ELECTRIC (RUSSIA) LLC  
52, bld.1 Kosmodamianskaya Nab. 115054, Moscow, Russia

Please be sure to put the contact address/telephone number on this manual before handing it to the customer.

**MITSUBISHI ELECTRIC CORPORATION**

HEAD OFFICE: TOKYO BUILDING, 2-7-3, MARUNOUCHI, CHIYODA-KU, TOKYO 100-8310, JAPAN