

# PARTS CATALOG R410A

**Outdoor unit**  
**[Model Name]**

PUHZ-ZRP35VKA2

**[Service Ref.]**

**PUHZ-ZRP35VKA2**

**PUHZ-ZRP35VKA2-ER**

**PUHZ-ZRP35VKA2-ET**

PUHZ-ZRP50VKA2

**PUHZ-ZRP50VKA2**

**PUHZ-ZRP50VKA2-ER**

**PUHZ-ZRP50VKA2-ET**

PUHZ-ZRP60VHA2

**PUHZ-ZRP60VHA2**

**PUHZ-ZRP60VHA2-ER**

**PUHZ-ZRP60VHA2-ET**

PUHZ-ZRP71VHA2

**PUHZ-ZRP71VHA2**

**PUHZ-ZRP71VHA2-ER**

**PUHZ-ZRP71VHA2-ET**

Note:

- This manual describes service data of the outdoor units only.

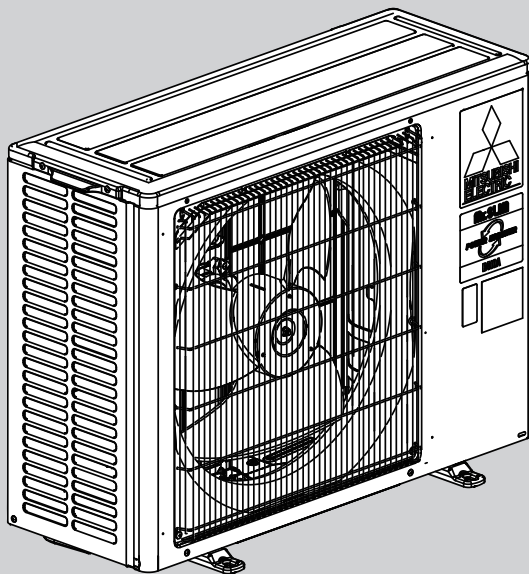

PUHZ-ZRP35VKA2  
PUHZ-ZRP50VKA2

## CONTENTS

1. RoHS PARTS LIST ..... 2

**SERVICE MANUAL (OCH635)**

FUNCTIONAL AND ELECTRICAL PARTS

PUHZ-ZRP35VKA2

PUHZ-ZRP50VKA2

PUHZ-ZRP35VKA2-ER

PUHZ-ZRP50VKA2-ER

PUHZ-ZRP35VKA2-ET

PUHZ-ZRP50VKA2-ET

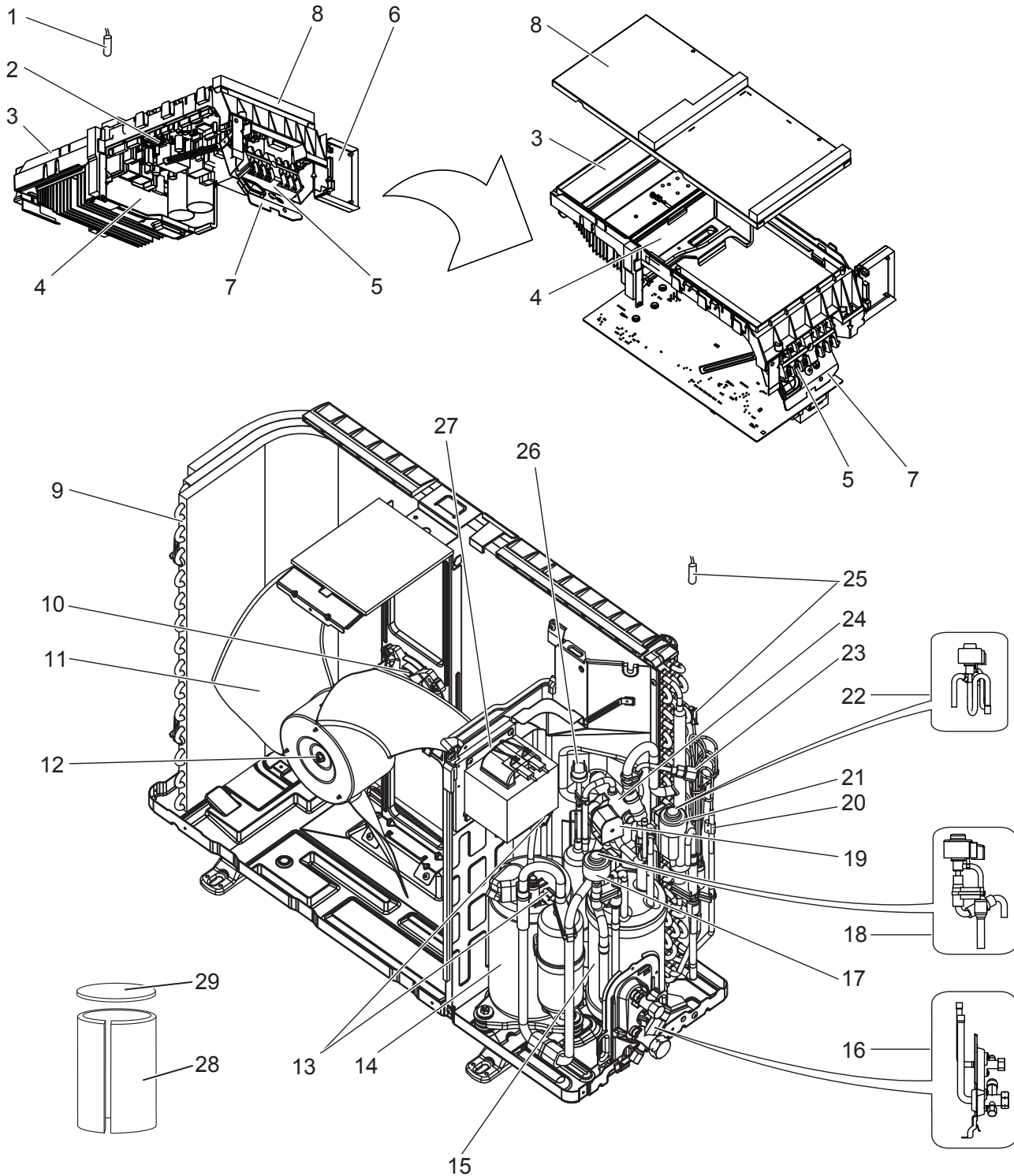

# RoHS PARTS LIST

Parts numbers that are circled are not shown in the figure.

No.	RoHS	Parts No.	Parts Name	Specification	Q'ty/unit						Remarks (Drawing No.)	Wiring Diagram Symbol
					PUHZ-ZRP35VKA2	PUHZ-ZRP50VKA2	PUHZ-ZRP35VKA2-ER	PUHZ-ZRP50VKA2-ER	PUHZ-ZRP35VKA2-ET	PUHZ-ZRP50VKA2-ET		
1	G	R01 M17 202	THERMISTOR	Heat Sink	1	1	1	1	1	1		TH8
2	G	T7W HC0 315	CONTROLLER BOARD		1	1	1	1	1	1		C.B.
3	G	R01 E00 327	P.B. SUPPORT		1	1	1	1	1	1		
4	G	R01 E01 327	H.S. SUPPORT		1	1	1	1	1	1		
5	G	T7W E71 716	TERMINAL BLOCK	6P (L,N,0,S1,S2,S3)	1	1	1	1	1	1		TB1
6	G	R01 E00 316	SWITCH BOARD		1	1	1	1	1	1		S.B.
7	G	—	T.B. SUPPORT		1	1	1	1	1	1	(BK00L098G07)	
8	G	R01 E00 325	P.B. COVER		1	1	1	1	1	1		
9	G	R01 H55 408	HEAT EXCHANGER		1		1		1			
	G	R01 H50 408	HEAT EXCHANGER			1		1		1		
10	G	R01 E55 221	FAN MOTOR		1	1	1	1	1	1		MF1
11	G	R01 E11 115	PROPELLER FAN		1	1	1	1	1	1		
12	G	R01 E03 097	NUT		1	1	1	1	1	1		
13	G	R01 M09 202	THERMISTOR	Discharge, Comp. surface	1	1	1	1	1	1		TH4,TH33
14	G	T92 263 124	COMPRESSOR	SNB092FGCM	1		1		1		Including RUBBER MOUNT	MC
	G	T97 418 607	COMPRESSOR	SNB130FGCM2		1		1		1	Including RUBBER MOUNT	MC
15	G	R01 E69 440	POWER RECEIVER		1	1	1	1	1	1		
16	G	R01 E34 410	STOP VALVE ASSY		1	1	1	1	1	1	Including STOP VALVES	
17	G	R01 H38 242	LEV COIL	CAM type	1	1	1	1	1	1	CONNECTOR: RED	LEV-B
18	G	T7W E92 401	LEV		1	1	1	1	1	1	Including coil for LEV-B	
19	G	T7W E62 242	SOLENOID COIL	4-WAY VALVE	1	1	1	1	1	1		21S4
20	G	R01 N25 202	THERMISTOR	Liquid	1	1	1	1	1	1		TH3
21	G	R01 H37 242	LEV COIL	CAM type	1	1	1	1	1	1	CONNECTOR: WHITE	LEV-A
22	G	T7W E91 401	LEV		1	1	1	1	1	1	Including coil for LEV-A	
23	G	R01 E24 413	CHARGE PLUG		1	1	1	1	1	1		
24	G	R01 E29 403	4-WAY VALVE		1	1	1	1	1	1		
25	G	R01 H83 202	THERMISTOR	2-Phase Pipe, Ambient	1	1	1	1	1	1		TH6,TH7
26	G	R01 E06 208	HIGH PRESSURE SWITCH		1	1	1	1	1	1		63H
27	G	R01 E46 259	REACTOR		1	1	1	1	1	1		ACL
28	G	R01 A52 602	COMP FELT (BODY)		1	1	1	1	1	1		
29	G	R01 A53 602	COMP FELT (TOP)		1	1	1	1	1	1		
30	G	R01 E21 239	FUSE	250V 10A	2	2	2	2	2	2		F1,F2
31	G	R01 E17 239	FUSE	250V 3.15A	2	2	2	2	2	2		F3,F4
32	G	R01 E10 510	LEAD ASSY COMP		1		1		1			
	G	R01 E11 510	LEAD ASSY COMP			1		1		1		

# RoHS PARTS LIST

## FUNCTIONAL AND ELECTRICAL PARTS

PUHZ-ZRP60VHA2

PUHZ-ZRP71VHA2

PUHZ-ZRP60VHA2-ER

PUHZ-ZRP71VHA2-ER

PUHZ-ZRP60VHA2-ET

PUHZ-ZRP71VHA2-ET

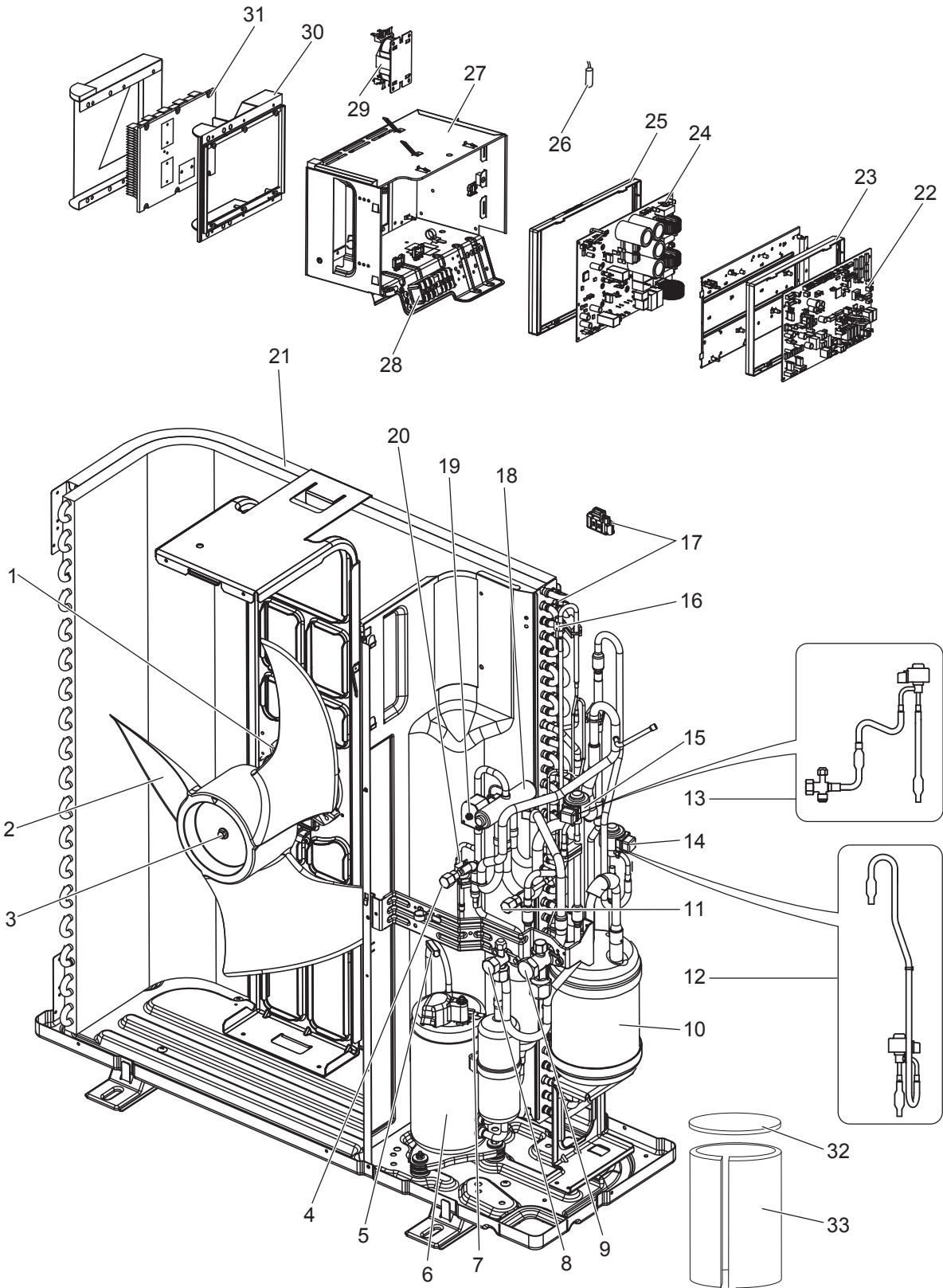

# RoHS PARTS LIST

Parts numbers that are circled are not shown in the figure.

No.	RoHS	Parts No.	Parts Name	Specification	Q'ty/unit						Remarks (Drawing No.)	Wiring Diagram Symbol
					PUHZ-ZRP60VHA2	PUHZ-ZRP71VHA2	PUHZ-ZRP60VHA2-ER	PUHZ-ZRP71VHA2-ER	PUHZ-ZRP60VHA2-ET	PUHZ-ZRP71VHA2-ET		
1	G	R01 E72 221	FAN MOTOR		1	1	1	1	1	1		MF1
2	G	R01 E12 115	PROPELLER FAN		1	1	1	1	1	1		
3	G	R01 E09 097	NUT		1	1	1	1	1	1		
4	G	R01 E24 413	CHARGE PLUG		1	1	1	1	1	1		
5	G	R01 E37 201	THERMISTOR	Discharge	1	1	1	1	1	1		TH4
6	G	T92 263 125	COMPRESSOR	SNB130FGCM1	1		1		1		Including RUBBER MOUNT	MC
	G	T92 272 607	COMPRESSOR	SNB172FSHM1		1		1		1	Including RUBBER MOUNT	MC
7	G	R01 E45 201	THERMISTOR	Comp. surface	1	1	1	1	1	1		TH33
8	G	R01 E25 410	STOP VALVE	3/8	1	1	1	1	1	1		
9	G	R01 E24 410	STOP VALVE	5/8	1	1	1	1	1	1		
10	G	R01 E62 440	POWER RECEIVER		1	1	1	1	1	1		
11	G	R01 E18 413	CHARGE PLUG		1	1	1	1	1	1		
12	G	R01 K06 401	LEV ASSY		1	1	1	1	1	1	Including coil for LEV-A	
13	G	R01 K07 401	LEV ASSY		1	1	1	1	1	1	Including coil for LEV-B & STV	
14	G	R01 H48 242	LEV COIL	CAM type	1	1	1	1	1	1	CONNECTOR: WHITE	LEV-A
15	G	R01 H49 242	LEV COIL	CAM type	1	1	1	1	1	1	CONNECTOR: RED	LEV-B
16	G	R01 H87 202	THERMISTOR	Liquid	1	1	1	1	1	1		TH3
17	G	R01 M18 202	THERMISTOR	2-Phase Pipe, Ambient	1	1	1	1	1	1		TH6, 7
18	G	R01 E13 403	4-WAY VALVE		1	1	1	1	1	1		
19	G	T7W E99 242	SOLENOID COIL	4-WAY VALVE	1	1	1	1	1	1		21S4
20	G	R01 E06 208	HIGH PRESSURE SWITCH		1	1	1	1	1	1		63H
21	G	R01 H51 408	HEAT EXCHANGER		1	1	1	1	1	1		
22	G	T7W HD0 315	CONTROLLER CIRCUIT BOARD		1	1	1	1	1	1		C.B.
23	G	—	BOARD CASE CONT		1	1	1	1	1	1	(BK25J874G02)	
24	G	T7W B60 323	POWER CIRCUIT BOARD		1	1	1	1	1	1		P.B.
25	G	—	BOARD CASE POWER		1	1	1	1	1	1	(BK25V224G01)	
26	G	R01 M15 202	THERMISTOR	Heat Sink	1	1	1	1	1	1		TH8
27	G	—	ELECTRICAL PARTS BOX		1	1	1	1	1	1	(BK00B472G46)	
28	G	T7W E71 716	TERMINAL BLOCK	6P (L,N,⊙,S1,S2,S3)	1	1	1	1	1	1		TB1
29	G	T7W E27 259	REACTOR		1	1	1	1	1	1		DCL1, DCL3
30	G	—	HEAT SINK CASE		1	1	1	1	1	1	(BK00T163G02)	
31	G	T7W A04 371	HEAT SINK		1	1	1	1	1	1		
32	G	R01 A59 602	COMP FELT (TOP)		1	1	1	1	1	1		
33	G	T7W A06 602	COMP FELT (BODY)		1	1	1	1	1	1		
34	G	R01 E14 239	FUSE	250V 6.3A	2	2	2	2	2	2		F3,F4
35	G	R01 E21 239	FUSE	250V 10A	2	2	2	2	2	2		F1,F2
36	G	T7W A10 510	LEAD ASSY COMP		1	1	1	1	1	1		

# RoHS PARTS LIST

## STRUCTURAL PARTS

PUHZ-ZRP35VKA2

PUHZ-ZRP35VKA2-ER

PUHZ-ZRP35VKA2-ET

PUHZ-ZRP50VKA2

PUHZ-ZRP50VKA2-ER

PUHZ-ZRP50VKA2-ET

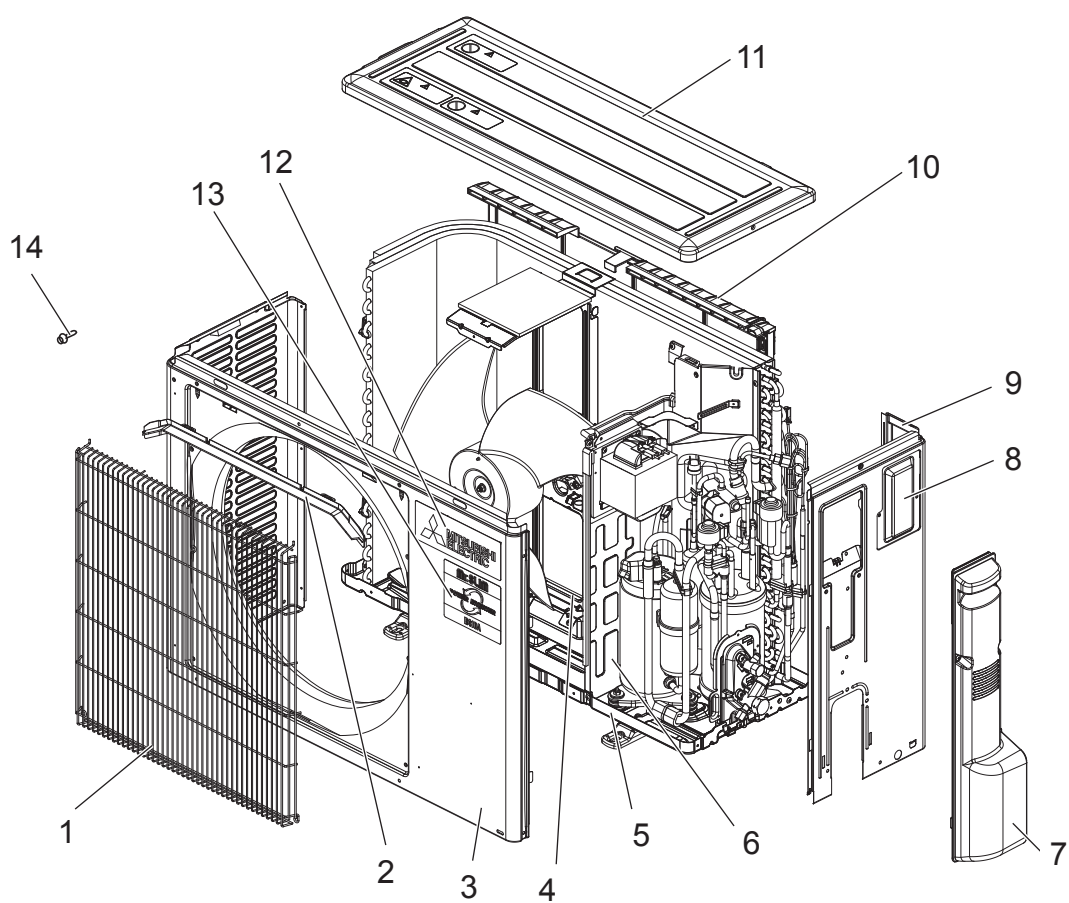

# RoHS PARTS LIST

No.	RoHS	Parts No.	Parts Name	Specification	Q'ty/unit						Remarks (Drawing No.)
					PUHZ-ZRP35VKA2	PUHZ-ZRP50VKA2	PUHZ-ZRP35VKA2-ER	PUHZ-ZRP50VKA2-ER	PUHZ-ZRP35VKA2-ET	PUHZ-ZRP50VKA2-ET	
1	G	R01 E61 691	GRILLE		1	1	1	1	1	1	
2	G	R01 E00 631	ICE GUARD		1	1	1	1	1	1	
3	G	R01 E21 668	FRONT PANEL		1	1	1	1	1	1	
4	G	R01 E45 130	MOTOR SUPPORT		1		1		1		
	G	R01 E46 130	MOTOR SUPPORT			1		1		1	
5	G	R01 E43 686	BASE ASSY		1	1	1	1	1	1	
6	G	—	SEPARATOR		1	1	1	1	1	1	(BK00J192G26)
7	G	R01 E28 667	SERVICE PANEL		1	1	1	1	1	1	
8	G	R01 E03 633	SERVICE PLATE		1	1	1	1	1	1	
9	G	R01 E12 682	BACK PANEL		1	1	1	1	1	1	Including service plate
10	G	R01 E04 684	REAR GUARD		1		1		1		
	G	R01 E05 684	REAR GUARD			1		1		1	
11	G	T7W E15 641	TOP PANEL		1	1	1	1	1	1	
12	G	T7W A00 005	BRAND LABEL (ME)		1	1	1	1	1	1	
13	G	T7W A09 005	BRAND LABEL (MR. SLIM)		1	1	1	1	1	1	
14	G	—	TS.ST SCREW	(4×10)	17	17	17	17	17	17	(Z504K189H37)



# RoHS PARTS LIST

## STRUCTURAL PARTS

PUHZ-ZRP60VHA2

PUHZ-ZRP60VHA2-ER

PUHZ-ZRP60VHA2-ET

PUHZ-ZRP71VHA2

PUHZ-ZRP71VHA2-ER

PUHZ-ZRP71VHA2-ET

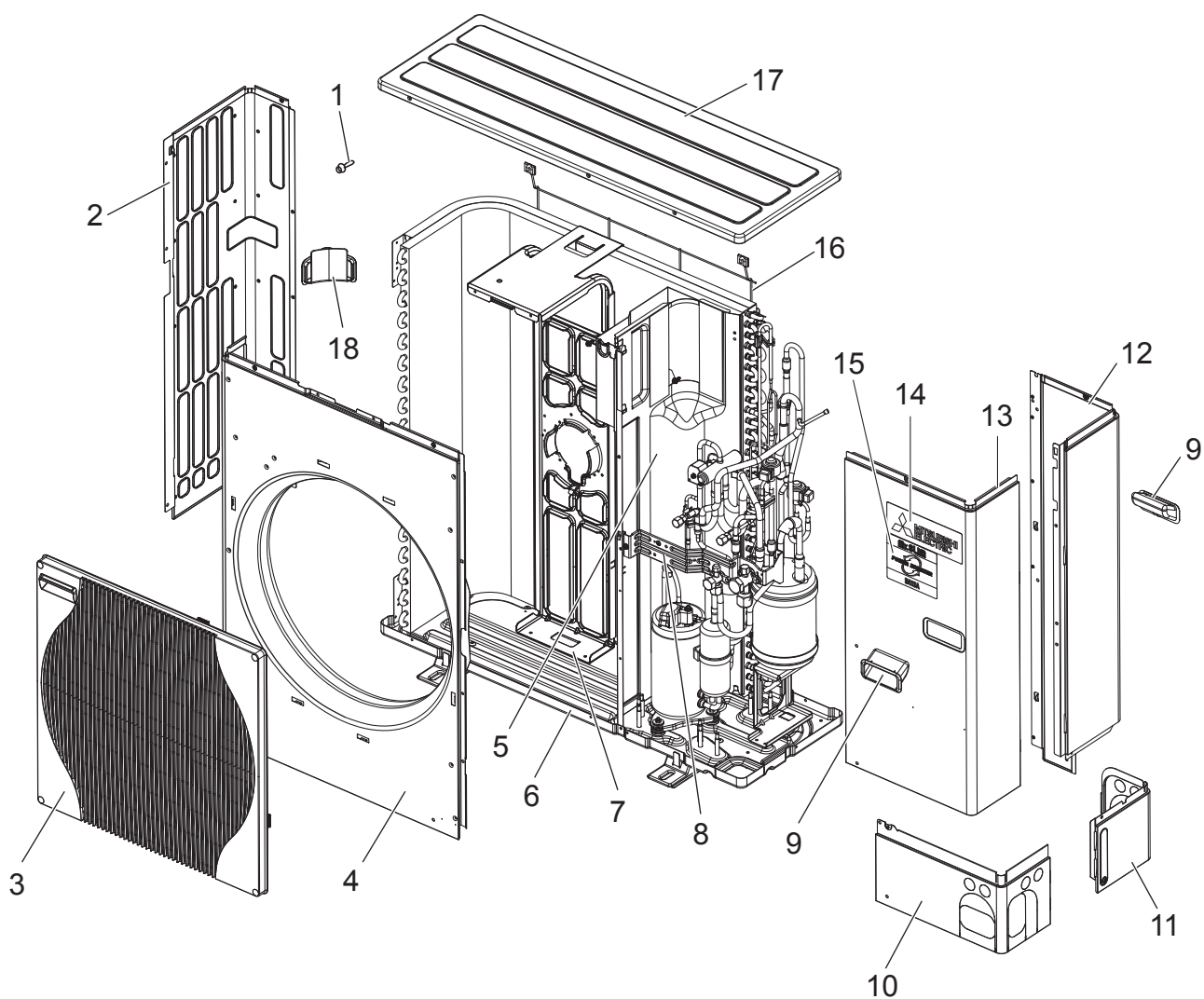



# RoHS PARTS LIST

No.	RoHS	Parts No.	Parts Name	Specification	Q'ty/unit						Remarks (Drawing No.)
					PUHZ-ZRP60VHA2	PUHZ-ZRP71VHA2	PUHZ-ZRP60VHA2-ER	PUHZ-ZRP71VHA2-ER	PUHZ-ZRP60VHA2-ET	PUHZ-ZRP71VHA2-ET	
1	G	—	F.ST SCREW	(5×12)	31	31	31	31	31	31	(DG12F536H12)
2	G	R01 E19 662	SIDE PANEL (L)		1	1	1	1	1	1	
3	G	R01 E33 691	GRILLE		1	1	1	1	1	1	
4	G	R01 E15 668	FRONT PANEL		1	1	1	1	1	1	
5	G	—	SEPARATOR		1	1	1	1	1	1	(BK00C374GY2)
6	G	R01 E44 686	BASE ASSY		1	1	1	1	1	1	
7	G	T7W E20 130	MOTOR SUPPORT		1	1	1	1	1	1	
8	G	—	VALVE BED ASSY		1	1	1	1	1	1	(BK00C375G17)
9	G	R01 E01 655	HANDLE		2	2	2	2	2	2	
10	G	R01 E40 658	COVER PANEL (FRONT)		1	1	1	1	1	1	
11	G	R01 E24 658	COVER PANEL (REAR)		1	1	1	1	1	1	
12	G	T7W E41 661	SIDE PANEL (R)		1	1	1	1	1	1	
13	G	T7W E10 667	SERVICE PANEL		1	1	1	1	1	1	
14	G	T7W A00 005	BRAND LABEL (ME)		1	1	1	1	1	1	
15	G	T7W A09 005	BRAND LABEL (MR. SLIM)		1	1	1	1	1	1	
16	G	R01 E06 698	REAR GUARD		1	1	1	1	1	1	
17	G	R01 E27 641	TOP PANEL		1	1	1	1	1	1	
18	G	R01 E02 655	HANDLE		1	1	1	1	1	1	

**Mr. SLIM**

**mitsubishi electric corporation**

HEAD OFFICE : TOKYO BUILDING, 2-7-3, MARUNOUCHI, CHIYODA-KU, TOKYO 100-8310, JAPAN