

INDOOR UNIT

**No. OBB766
REVISED EDITION-A**

PARTS CATALOG

Models

MSZ-LN18VGW - E1
MSZ-LN18VGV - E1
MSZ-LN18VGB - E1
MSZ-LN18VGR - E1
MSZ-LN25VGW - E1, ER1
MSZ-LN25VGV - E1, ER1
MSZ-LN25VGB - E1, ER1
MSZ-LN25VGR - E1, ER1
MSZ-LN35VGW - E1, ER1
MSZ-LN35VGV - E1, ER1
MSZ-LN35VGB - E1, ER1
MSZ-LN35VGR - E1, ER1

MSZ-LN50VGW - E1, ER1
MSZ-LN50VGV - E1, ER1
MSZ-LN50VGB - E1, ER1
MSZ-LN50VGR - E1, ER1
MSZ-LN60VGW - E1, ER1
MSZ-LN60VGV - E1, ER1
MSZ-LN60VGB - E1, ER1
MSZ-LN60VGR - E1, ER1

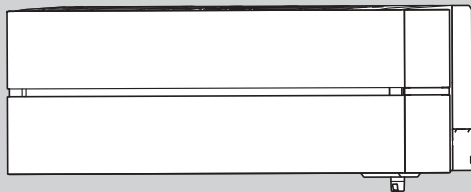

CONTENTS

1. RoHS PARTS LIST..... 2
2. OPTIONAL PARTS..... 32

SERVICE MANUAL (OBH766)

NOTE:

RoHS compliant products have <G> mark on the spec name plate.

Revision A:

• MSZ-LN18VGW/V/B/R-  have been added.

1

RoHS PARTS LIST

MSZ-LN18VGW MSZ-LN18VGV MSZ-LN18VGB MSZ-LN18VGR

1-1. INDOOR UNIT STRUCTURAL PARTS

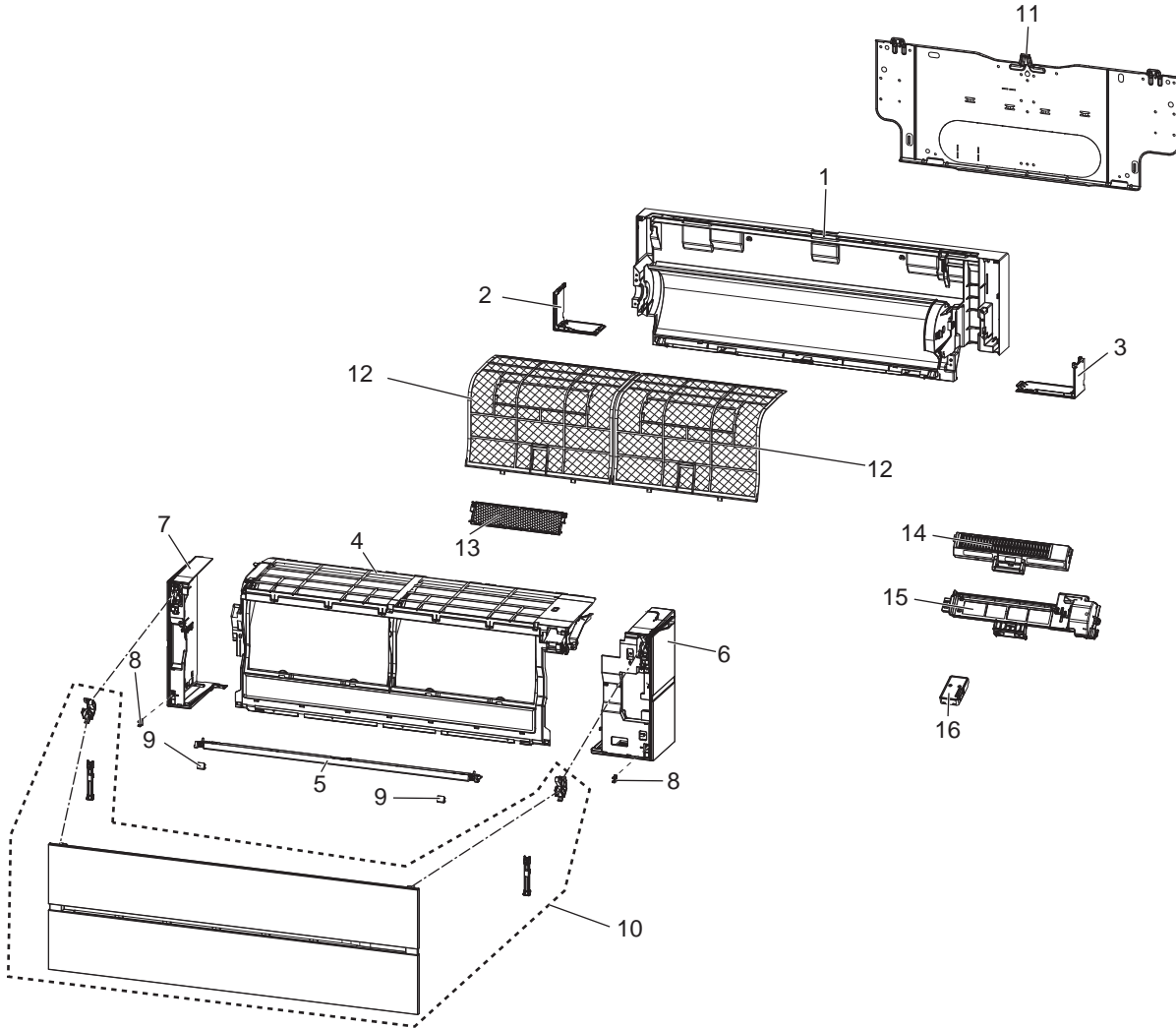

1-2. ACCESSORY AND REMOTE CONTROLLER



RoHS PARTS LIST

1-1. INDOOR UNIT STRUCTURAL PARTS

No.	RoHS	Part No.	Part name	Symbol in Wiring Diagram	Q'ty/unit				Remarks
					MSZ-LN				
					18				
					VGW- <u>E1</u>	VGW- <u>E1</u>	VGB- <u>E1</u>	VGR- <u>E1</u>	
1	G	E12 Y52 234	BOX ASSEMBLY		1	1			
	G	E12 Y60 234	BOX ASSEMBLY				1	1	
2	G	E12 Y52 976	CORNER BOX (L)		1	1			
	G	E12 Y60 976	CORNER BOX (L)				1	1	
3	G	E12 Y52 975	CORNER BOX (R)		1	1			
	G	E12 Y60 975	CORNER BOX (R)				1	1	
4	G	E12 Y52 000	PANEL ASSEMBLY (F)		1	1			
	G	E12 Y60 000	PANEL ASSEMBLY (F)				1	1	
5	G	E12 Y52 717	PANEL (U)		1	1			
	G	E12 Y60 717	PANEL (U)				1		
	G	E12 Y64 717	PANEL (U)					1	
6	G	E12 Y52 085	PANEL ASSEMBLY (R)		1				
	G	E12 Y56 085	PANEL ASSEMBLY (R)			1			
	G	E12 Y60 085	PANEL ASSEMBLY (R)				1		
	G	E12 Y64 085	PANEL ASSEMBLY (R)					1	
7	G	E12 Y52 086	PANEL ASSEMBLY (L)		1				
	G	E12 Y56 086	PANEL ASSEMBLY (L)			1			
	G	E12 Y60 086	PANEL ASSEMBLY (L)				1		
	G	E12 Y64 086	PANEL ASSEMBLY (L)					1	
8	G	E12 F95 142	CATCH		2	2	2	2	2 PCS/SET
9	G	E12 Y52 067	SCREW CAP		2	2			
	G	E12 Y60 067	SCREW CAP				2		
	G	E12 Y64 067	SCREW CAP					2	
10	G	E12 Y52 010	FRONT PANEL		1				
	G	E12 Y56 010	FRONT PANEL			1			
	G	E12 Y60 010	FRONT PANEL				1		
	G	E12 Y64 010	FRONT PANEL					1	
11	G	E12 Y52 970	INSTALLATION PLATE		1	1	1	1	
12	G	E12 Y52 100	AIR FILTER		2	2	2		1 PC/SET
	G	E12 Y64 100	AIR FILTER					2	1 PC/SET
13	G	-	AIR CLEANING FILTER (DEODORIZING FILTER)		1	1	1	1	1 PC/SET MAC-3010FT-E
14	G	E12 Y52 774	AIR PURIFYING DEVICE		1	1	1	1	
15	G	E12 Y52 775	AIR PURIFYING DEVICE SUPPORT		1	1	1	1	
16	G	E12 Y52 457	Wi-Fi INTERFACE MAC-567IFB-E		1	1	1	1	MAC-567IFB-E

1-2. ACCESSORY AND REMOTE CONTROLLER

No.	RoHS	Part No.	Part name	Symbol in Wiring Diagram	Q'ty/unit				Remarks
					MSZ-LN				
					18				
					VGW- <u>E1</u>	VGW- <u>E1</u>	VGB- <u>E1</u>	VGR- <u>E1</u>	
17	G	E12 Y52 426	REMOTE CONTROLLER		1				SG16L
	G	E12 Y56 426	REMOTE CONTROLLER			1			XG16A
	G	E12 Y60 426	REMOTE CONTROLLER				1		XG16C
	G	E12 Y64 426	REMOTE CONTROLLER					1	XG16B

RoHS PARTS LIST

MSZ-LN18VGW MSZ-LN18VGV MSZ-LN18VGB MSZ-LN18VGR 1-3. INDOOR UNIT ELECTRICAL PARTS AND FUNCTIONAL PARTS

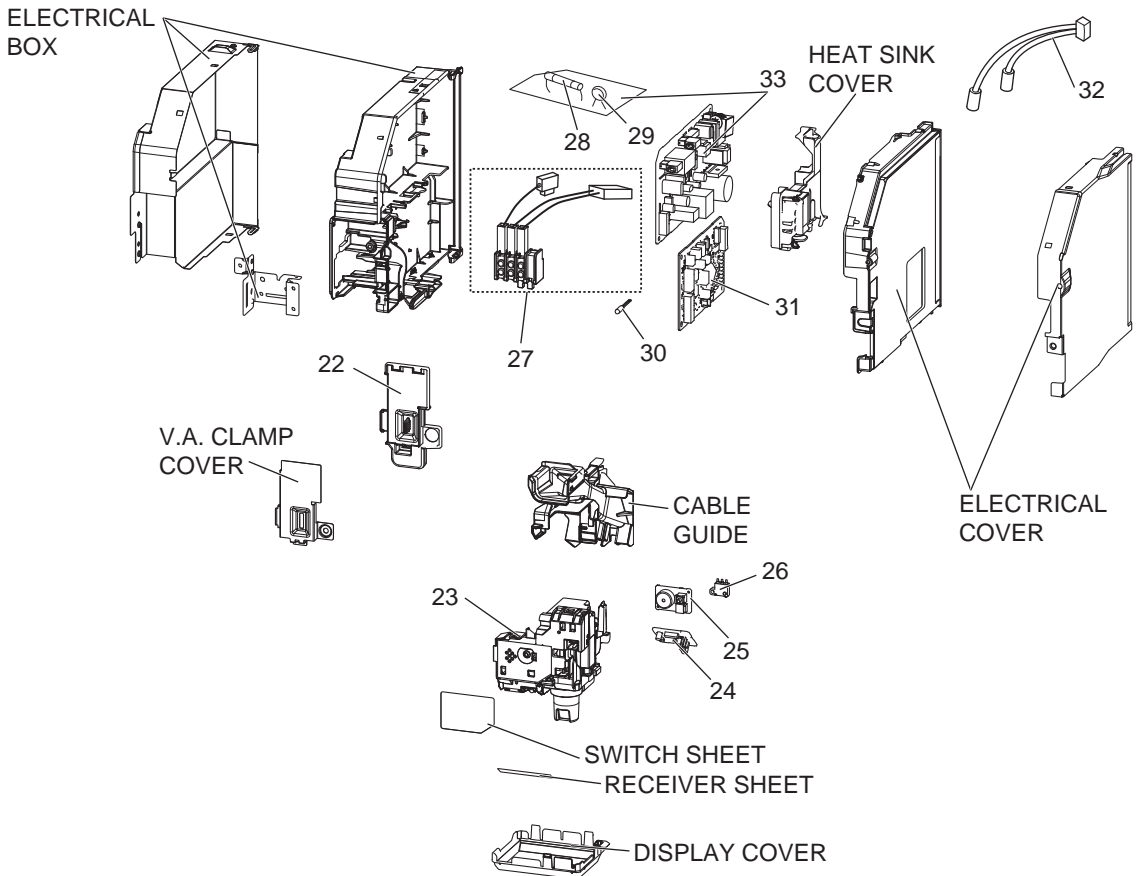
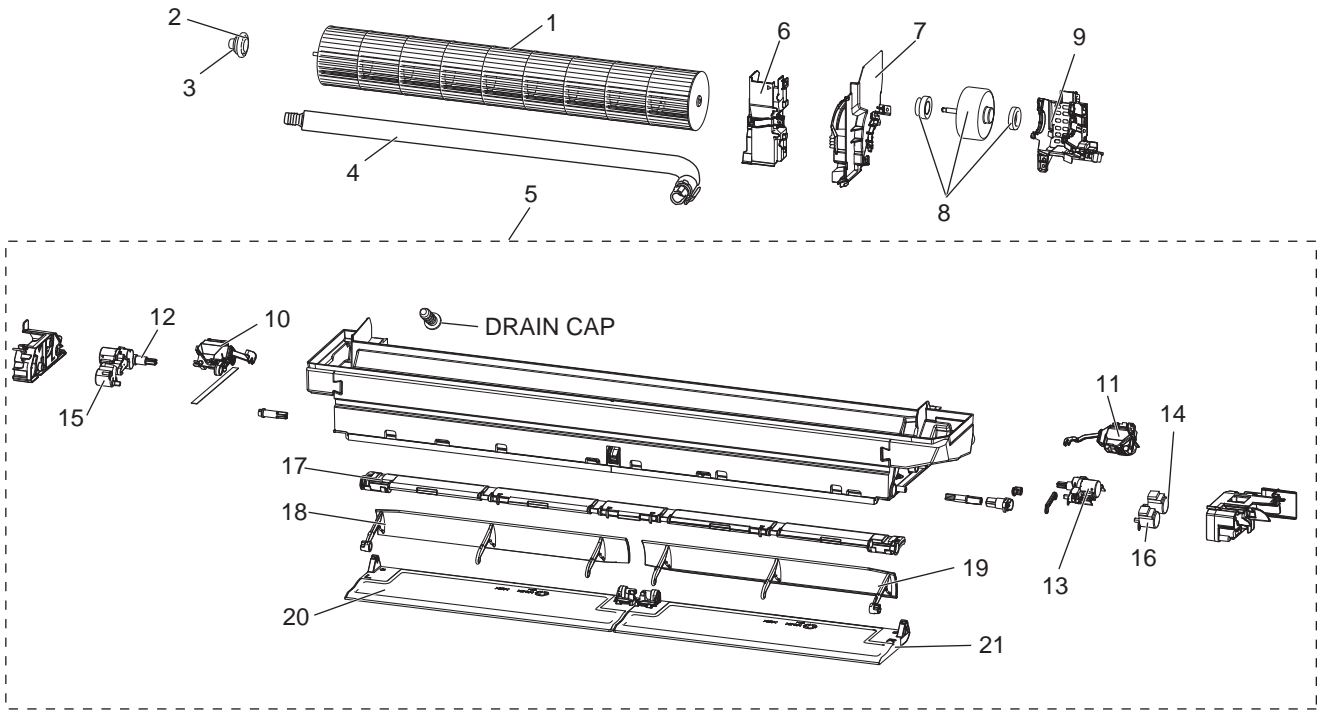

RoHS PARTS LIST

1-3. INDOOR UNIT ELECTRICAL PARTS AND FUNCTIONAL PARTS

No.	RoHS	Part No.	Part name	Symbol in Wiring Diagram	Q'ty/unit				Remarks
					MSZ-LN				
					18				
VGW- ^{E1}	VGW- ^{E1}	VGB- ^{E1}	VGR- ^{E1}						
1	G	E12 Y52 302	LINE FLOW FAN		1	1	1	1	
2	G	E12 001 504	SLEEVE BEARING		1	1	1	1	
3	G	E12 751 509	BEARING MOUNT		1	1	1	1	
4	G	E12 T20 702	DRAIN HOSE		1	1	1	1	
5	G	E12 Y52 235	NOZZLE ASSEMBLY		1	1			
	G	E12 Y60 235	NOZZLE ASSEMBLY				1		
	G	E12 Y64 235	NOZZLE ASSEMBLY					1	
6	G	E12 Y52 541	WATER COVER		1	1	1	1	
7	G	E12 Y52 333	MOTOR BAND		1	1	1	1	
8	G	E12 Y52 300	INDOOR FAN MOTOR	MF	1	1	1	1	RC0J30-□□
9	G	E12 20A 333	MOTOR BED		1	1	1	1	
10	G	E12 J44 303	VANE MOTOR (L) (VERTICAL)	MV2	1	1	1	1	(RIGHT & LEFT)
11	G	E12 J44 303	VANE MOTOR (R) (VERTICAL)	MV2	1	1	1	1	(RIGHT & LEFT)
12	G	E12 Y54 303	OUTER VANE MOTOR (L) (HORIZONTAL)	MV1	1	1	1	1	(UP & DOWN)
13	G	E12 Y53 303	OUTER VANE MOTOR (R) (HORIZONTAL)	MV1	1	1	1	1	(UP & DOWN)
14	G	E12 A89 303	VANE MOTOR (HORIZONTAL)	MV1	1	1	1	1	(UP & DOWN)
15	G	E12 A89 303	VANE MOTOR (L) (HORIZONTAL)	MV1	1	1	1	1	(UP & DOWN)
16	G	E12 A89 303	VANE MOTOR (R) (HORIZONTAL)	MV1	1	1	1	1	(UP & DOWN)
17	G	E12 Y52 046	VANE SLIDE ASSEMBLY		1	1			
	G	E12 Y60 046	VANE SLIDE ASSEMBLY				1	1	
18	G	E12 Y53 040	INNER VANE (L)		1	1	1	1	
19	G	E12 Y52 040	INNER VANE (R)		1	1	1	1	
20	G	E12 Y53 041	OUTER VANE (L)		1	1			
	G	E12 Y61 041	OUTER VANE (L)				1		
	G	E12 Y65 041	OUTER VANE (L)					1	
21	G	E12 Y52 041	OUTER VANE (R)		1	1			
	G	E12 Y60 041	OUTER VANE (R)				1		
	G	E12 Y64 041	OUTER VANE (R)					1	
22	G	E12 Y52 784	V.A. CLAMP		1	1	1	1	
23	G	E12 Y52 391	DISPLAY AND i-see SENSOR ASSEMBLY	MT	1	1			
	G	E12 Y60 391	DISPLAY AND i-see SENSOR ASSEMBLY	MT			1	1	
24	G	E12 Y52 468	DISPLAY AND RECEIVER P.C. BOARD		1	1	1	1	
25	G	E12 Y52 326	SWITCH BUZZER P.C. BOARD		1	1	1	1	
26	G	E12 Y52 316	INTER LOCK SWITCH (AIR PURIFYING DEVICE)		1	1	1	1	
27	G	E12 T21 375	TERMINAL BLOCK	TB	1	1	1	1	3P
28	G	E12 A49 382	FUSE	F11	1	1	1	1	T3.15AL250V
29	G	E12 B75 385	VARISTOR	NR11	1	1	1	1	
30	G	E12 Y52 308	ROOM TEMPERATURE THERMISTOR	RT11	1	1	1	1	
31	G	E12 15D 452	ELECTRONIC CONTROL P.C. BOARD		1	1	1	1	
32	G	E12 Y52 307	INDOOR COIL THERMISTOR	RT12, RT13	1	1	1	1	
33	G	E12 Y52 440	POWER P.C. BOARD		1	1	1	1	

RoHS PARTS LIST

MSZ-LN18VGW MSZ-LN18VGV MSZ-LN18VGB MSZ-LN18VGR
1-4. INDOOR UNIT HEAT EXCHANGER

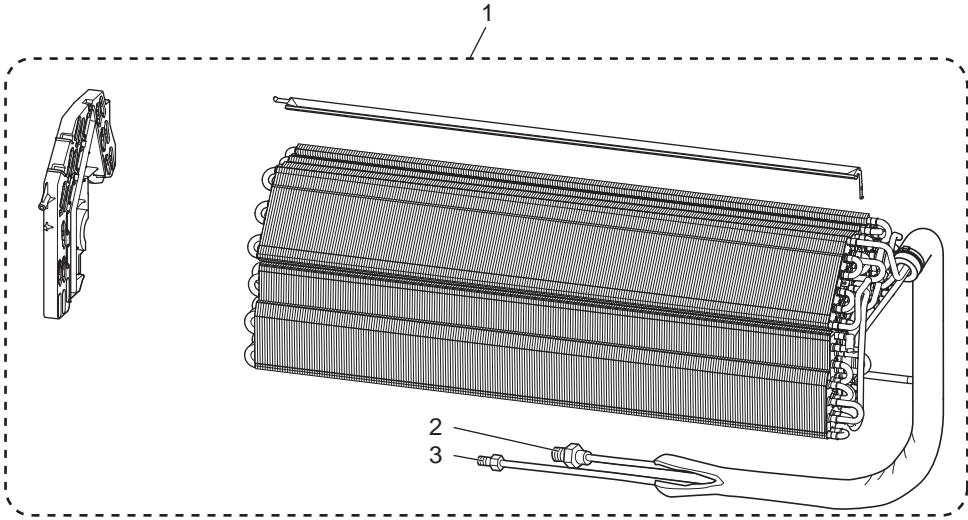

RoHS PARTS LIST

1-4. INDOOR UNIT HEAT EXCHANGER

No.	RoHS	Part No.	Part name	Symbol in Wiring Diagram	Q'ty/unit				Remarks
					MSZ-LN				
					18				
VGW- ^[E1]	VGV- ^[E1]	VGB- ^[E1]	VGR- ^[E1]						
1	G	E12 Y52 620	INDOOR HEAT EXCHANGER		1	1	1	1	
2	G	E12 815 666	UNION (GAS)		1	1	1	1	ø9.52
3	G	E12 151 667	UNION (LIQUID)		1	1	1	1	ø6.35

RoHS PARTS LIST

MSZ-LN25VGW MSZ-LN25VGV MSZ-LN25VGB MSZ-LN25VGR
MSZ-LN35VGW MSZ-LN35VGV MSZ-LN35VGB MSZ-LN35VGR

1-5. INDOOR UNIT STRUCTURAL PARTS

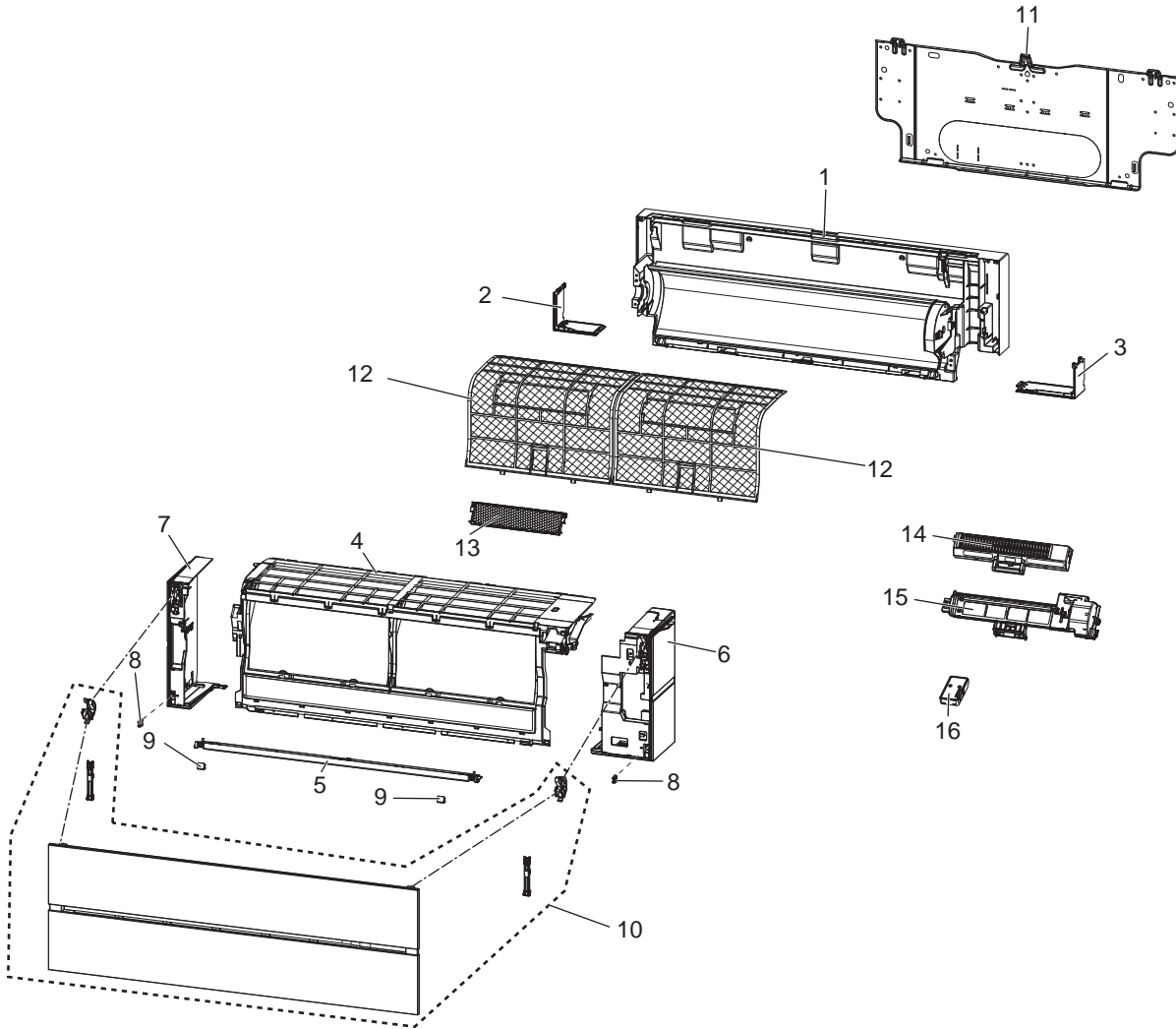

1-6. ACCESSORY AND REMOTE CONTROLLER



RoHS PARTS LIST

1-5. INDOOR UNIT STRUCTURAL PARTS

No.	RoHS	Part No.	Part name	Symbol in Wiring Diagram	Q'ty/unit								Remarks	
					MSZ-LN									
					25				35					
VGW	VGW	VGW	VGW	VGW	VGW	VGW	VGW	VGW	VGW					
-E1	-E1	-E1	-E1	-E1	-E1	-E1	-E1	-E1	-E1					
1	G	E12 Y52 234	BOX ASSEMBLY		1	1			1	1				
	G	E12 Y60 234	BOX ASSEMBLY				1	1			1	1		
2	G	E12 Y52 976	CORNER BOX (L)		1	1			1	1				
	G	E12 Y60 976	CORNER BOX (L)				1	1			1	1		
3	G	E12 Y52 975	CORNER BOX (R)		1	1			1	1				
	G	E12 Y60 975	CORNER BOX (R)				1	1			1	1		
4	G	E12 Y52 000	PANEL ASSEMBLY (F)		1	1			1	1				
	G	E12 Y60 000	PANEL ASSEMBLY (F)				1	1			1	1		
5	G	E12 Y52 717	PANEL (U)		1	1			1	1				
	G	E12 Y60 717	PANEL (U)				1				1			
	G	E12 Y64 717	PANEL (U)					1				1		
6	G	E12 Y52 085	PANEL ASSEMBLY (R)		1				1					
	G	E12 Y56 085	PANEL ASSEMBLY (R)			1				1				
	G	E12 Y60 085	PANEL ASSEMBLY (R)				1				1			
	G	E12 Y64 085	PANEL ASSEMBLY (R)					1				1		
7	G	E12 Y52 086	PANEL ASSEMBLY (L)		1				1					
	G	E12 Y56 086	PANEL ASSEMBLY (L)			1				1				
	G	E12 Y60 086	PANEL ASSEMBLY (L)				1				1			
	G	E12 Y64 086	PANEL ASSEMBLY (L)					1				1		
8	G	E12 F95 142	CATCH		2	2	2	2	2	2	2	2	2	2 PCS/SET
9	G	E12 Y52 067	SCREW CAP		2	2			2	2				
	G	E12 Y60 067	SCREW CAP				2				2			
	G	E12 Y64 067	SCREW CAP					2				2		
10	G	E12 Y52 010	FRONT PANEL		1				1					
	G	E12 Y56 010	FRONT PANEL			1				1				
	G	E12 Y60 010	FRONT PANEL				1				1			
	G	E12 Y64 010	FRONT PANEL					1				1		
11	G	E12 Y52 970	INSTALLATION PLATE		1	1	1	1	1	1	1	1	1	
12	G	E12 Y52 100	AIR FILTER		2	2	2		2	2	2			1 PC/SET
	G	E12 Y64 100	AIR FILTER					2				2		1 PC/SET
13	G	-	AIR CLEANING FILTER (DEODORIZING FILTER)		1	1	1	1	1	1	1	1	1	1 PC/SET MAC-3010FT-E
14	G	E12 Y52 774	AIR PURIFYING DEVICE		1	1	1	1	1	1	1	1	1	
15	G	E12 Y52 775	AIR PURIFYING DEVICE SUPPORT		1	1	1	1	1	1	1	1	1	
16	G	E12 Y52 457	Wi-Fi INTERFACE MAC-567IFB-E		1	1	1	1	1	1	1	1	1	MAC-567IFB-E

1-6. ACCESSORY AND REMOTE CONTROLLER

No.	RoHS	Part No.	Part name	Symbol in Wiring Diagram	Q'ty/unit								Remarks	
					MSZ-LN									
					25				35					
VGW	VGW	VGW	VGW	VGW	VGW	VGW	VGW	VGW	VGW					
-E1	-E1	-E1	-E1	-E1	-E1	-E1	-E1	-E1	-E1					
17	G	E12 Y52 426	REMOTE CONTROLLER		1				1					SG16L
	G	E12 Y56 426	REMOTE CONTROLLER			1				1				XG16A
	G	E12 Y60 426	REMOTE CONTROLLER				1				1			XG16C
	G	E12 Y64 426	REMOTE CONTROLLER					1				1		XG16B

RoHS PARTS LIST

MSZ-LN25VGW MSZ-LN25GV MSZ-LN25VGB MSZ-LN25VGR
 MSZ-LN35VGW MSZ-LN35GV MSZ-LN35VGB MSZ-LN35VGR
 1-7. INDOOR UNIT ELECTRICAL PARTS AND FUNCTIONAL PARTS

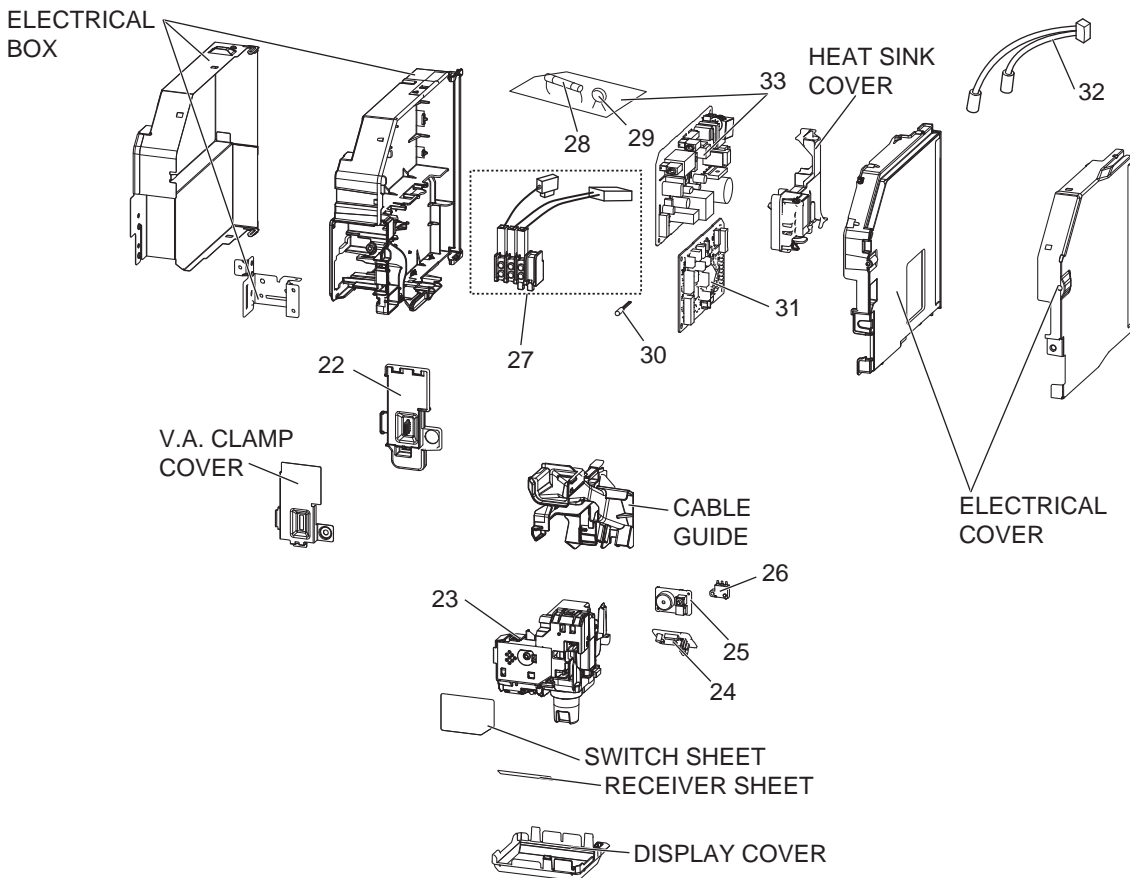
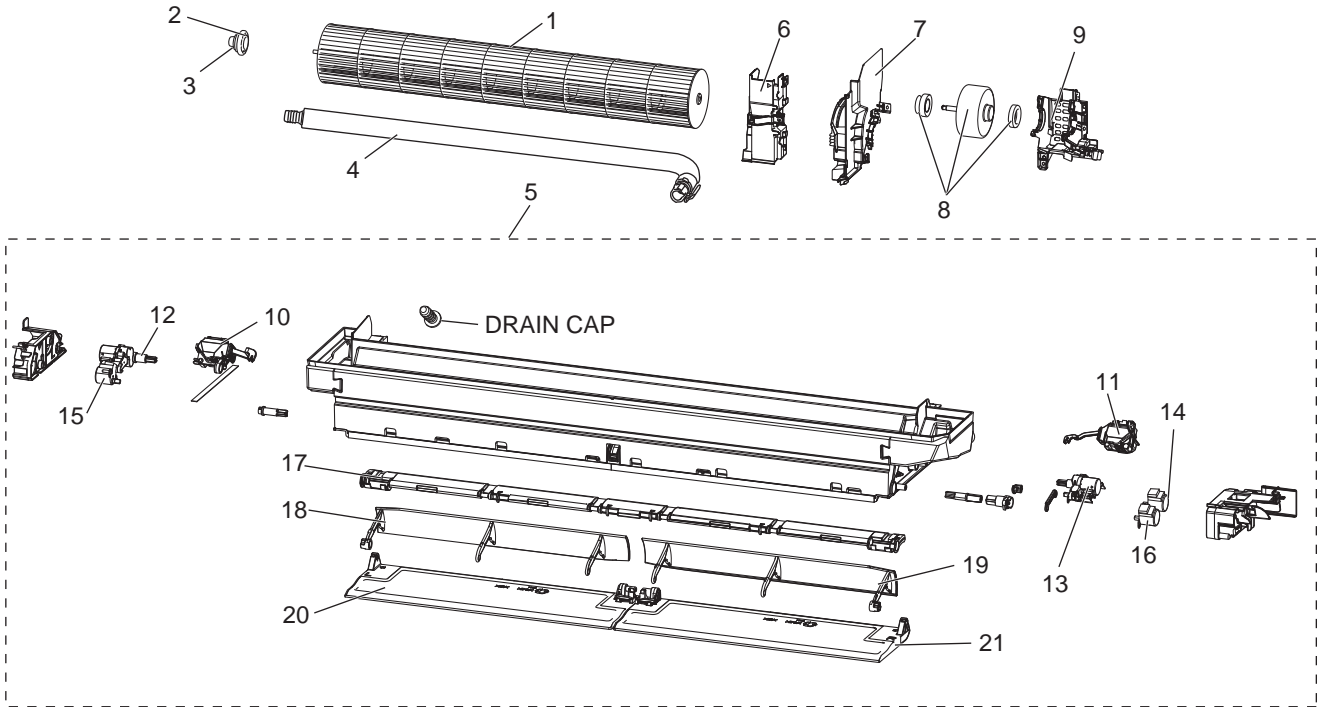

RoHS PARTS LIST

1-7. INDOOR UNIT ELECTRICAL PARTS AND FUNCTIONAL PARTS

No.	RoHS	Part No.	Part name	Symbol in Wiring Diagram	Q'ty/unit								Remarks
					MSZ-LN								
					25				35				
VGW	VGW	VGV	VGV	VGB	VGB	VGR	VGR	VGB	VGB	VGR	VGR		
-E1	-E1	-E1	-E1	-E1	-E1	-E1	-E1	-E1	-E1	-E1	-E1		
1	G	E12 Y52 302	LINE FLOW FAN		1	1	1	1	1	1	1	1	
2	G	E12 001 504	SLEEVE BEARING		1	1	1	1	1	1	1	1	
3	G	E12 751 509	BEARING MOUNT		1	1	1	1	1	1	1	1	
4	G	E12 T20 702	DRAIN HOSE		1	1	1	1	1	1	1	1	
5	G	E12 Y52 235	NOZZLE ASSEMBLY		1	1			1	1			
	G	E12 Y60 235	NOZZLE ASSEMBLY				1				1		
	G	E12 Y64 235	NOZZLE ASSEMBLY					1				1	
6	G	E12 Y52 541	WATER COVER		1	1	1	1	1	1	1	1	
7	G	E12 Y52 333	MOTOR BAND		1	1	1	1	1	1	1	1	
8	G	E12 Y52 300	INDOOR FAN MOTOR	MF	1	1	1	1	1	1	1	1	RC0J30-□□
9	G	E12 20A 333	MOTOR BED		1	1	1	1	1	1	1	1	
10	G	E12 J44 303	VANE MOTOR (L) (VERTICAL)	MV2	1	1	1	1	1	1	1	1	(RIGHT & LEFT)
11	G	E12 J44 303	VANE MOTOR (R) (VERTICAL)	MV2	1	1	1	1	1	1	1	1	(RIGHT & LEFT)
12	G	E12 Y54 303	OUTER VANE MOTOR (L) (HORIZONTAL)	MV1	1	1	1	1	1	1	1	1	(UP & DOWN)
13	G	E12 Y53 303	OUTER VANE MOTOR (R) (HORIZONTAL)	MV1	1	1	1	1	1	1	1	1	(UP & DOWN)
14	G	E12 A89 303	VANE MOTOR (HORIZONTAL)	MV1	1	1	1	1	1	1	1	1	(UP & DOWN)
15	G	E12 A89 303	VANE MOTOR (L) (HORIZONTAL)	MV1	1	1	1	1	1	1	1	1	(UP & DOWN)
16	G	E12 A89 303	VANE MOTOR (R) (HORIZONTAL)	MV1	1	1	1	1	1	1	1	1	(UP & DOWN)
17	G	E12 Y52 046	VANE SLIDE ASSEMBLY		1	1			1	1			
	G	E12 Y60 046	VANE SLIDE ASSEMBLY				1	1			1	1	
18	G	E12 Y53 040	INNER VANE (L)		1	1	1	1	1	1	1	1	
19	G	E12 Y52 040	INNER VANE (R)		1	1	1	1	1	1	1	1	
20	G	E12 Y53 041	OUTER VANE (L)		1	1			1	1			
	G	E12 Y61 041	OUTER VANE (L)				1				1		
	G	E12 Y65 041	OUTER VANE (L)					1				1	
21	G	E12 Y52 041	OUTER VANE (R)		1	1			1	1			
	G	E12 Y60 041	OUTER VANE (R)				1				1		
	G	E12 Y64 041	OUTER VANE (R)					1				1	
22	G	E12 Y52 784	V.A. CLAMP		1	1	1	1	1	1	1	1	
23	G	E12 Y52 391	DISPLAY AND i-see SENSOR ASSEMBLY	MT	1	1			1	1			
	G	E12 Y60 391	DISPLAY AND i-see SENSOR ASSEMBLY	MT			1	1			1	1	
24	G	E12 Y52 468	DISPLAY AND RECEIVER P.C. BOARD		1	1	1	1	1	1	1	1	
25	G	E12 Y52 326	SWITCH BUZZER P.C. BOARD		1	1	1	1	1	1	1	1	
26	G	E12 Y52 316	INTER LOCK SWITCH (AIR PURIFYING DEVICE)		1	1	1	1	1	1	1	1	
27	G	E12 T21 375	TERMINAL BLOCK	TB	1	1	1	1	1	1	1	1	3P
28	G	E12 A49 382	FUSE	F11	1	1	1	1	1	1	1	1	T3.15AL250V
29	G	E12 B75 385	VARISTOR	NR11	1	1	1	1	1	1	1	1	
30	G	E12 Y52 308	ROOM TEMPERATURE THERMISTOR	RT11	1	1	1	1	1	1	1	1	
31	G	E12 Y52 452	ELECTRONIC CONTROL P.C. BOARD		1	1	1	1					
	G	E12 Y53 452	ELECTRONIC CONTROL P.C. BOARD						1	1	1	1	
32	G	E12 Y52 307	INDOOR COIL THERMISTOR	RT12, RT13	1	1	1	1	1	1	1	1	
33	G	E12 Y52 440	POWER P.C. BOARD		1	1	1	1	1	1	1	1	

RoHS PARTS LIST

MSZ-LN25VGW MSZ-LN25VGV MSZ-LN25VGB MSZ-LN25VGR
MSZ-LN35VGW MSZ-LN35VGV MSZ-LN35VGB MSZ-LN35VGR

1-8. INDOOR UNIT HEAT EXCHANGER

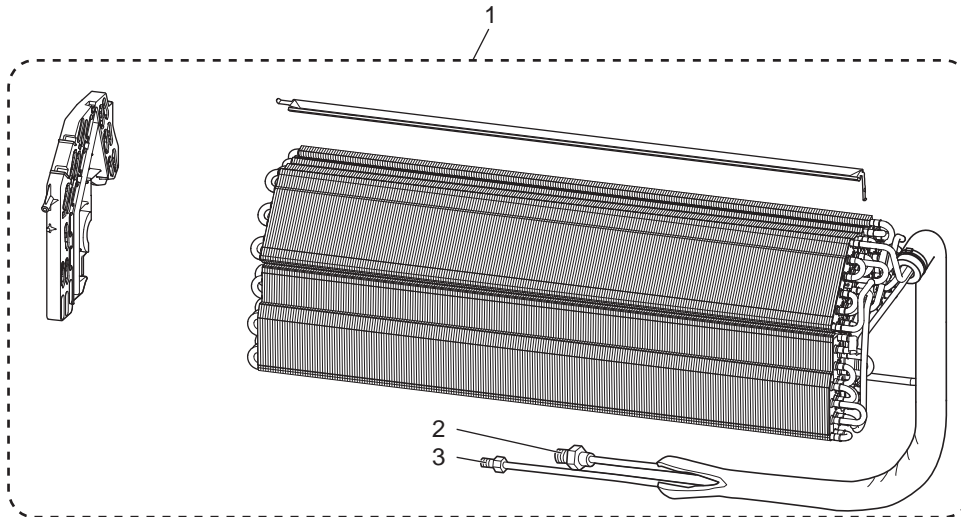

RoHS PARTS LIST

1-8. INDOOR UNIT HEAT EXCHANGER

No.	RoHS	Part No.	Part name	Symbol in Wiring Diagram	Q'ty/unit MSZ-LN								Remarks
					25				35				
					VGW -E1	VGW -E1	VGB -E1	VGR -E1	VGW -E1	VGW -E1	VGB -E1	VGR -E1	
1	G	E12 Y52 620	INDOOR HEAT EXCHANGER		1	1	1	1	1	1	1	1	
2	G	E12 815 666	UNION (GAS)		1	1	1	1	1	1	1	1	ø9.52
3	G	E12 151 667	UNION (LIQUID)		1	1	1	1	1	1	1	1	ø6.35

RoHS PARTS LIST

MSZ-LN25VGW MSZ-LN25VGV MSZ-LN25VGB MSZ-LN25VGR
MSZ-LN35VGW MSZ-LN35VGV MSZ-LN35VGB MSZ-LN35VGR

1-9. INDOOR UNIT STRUCTURAL PARTS

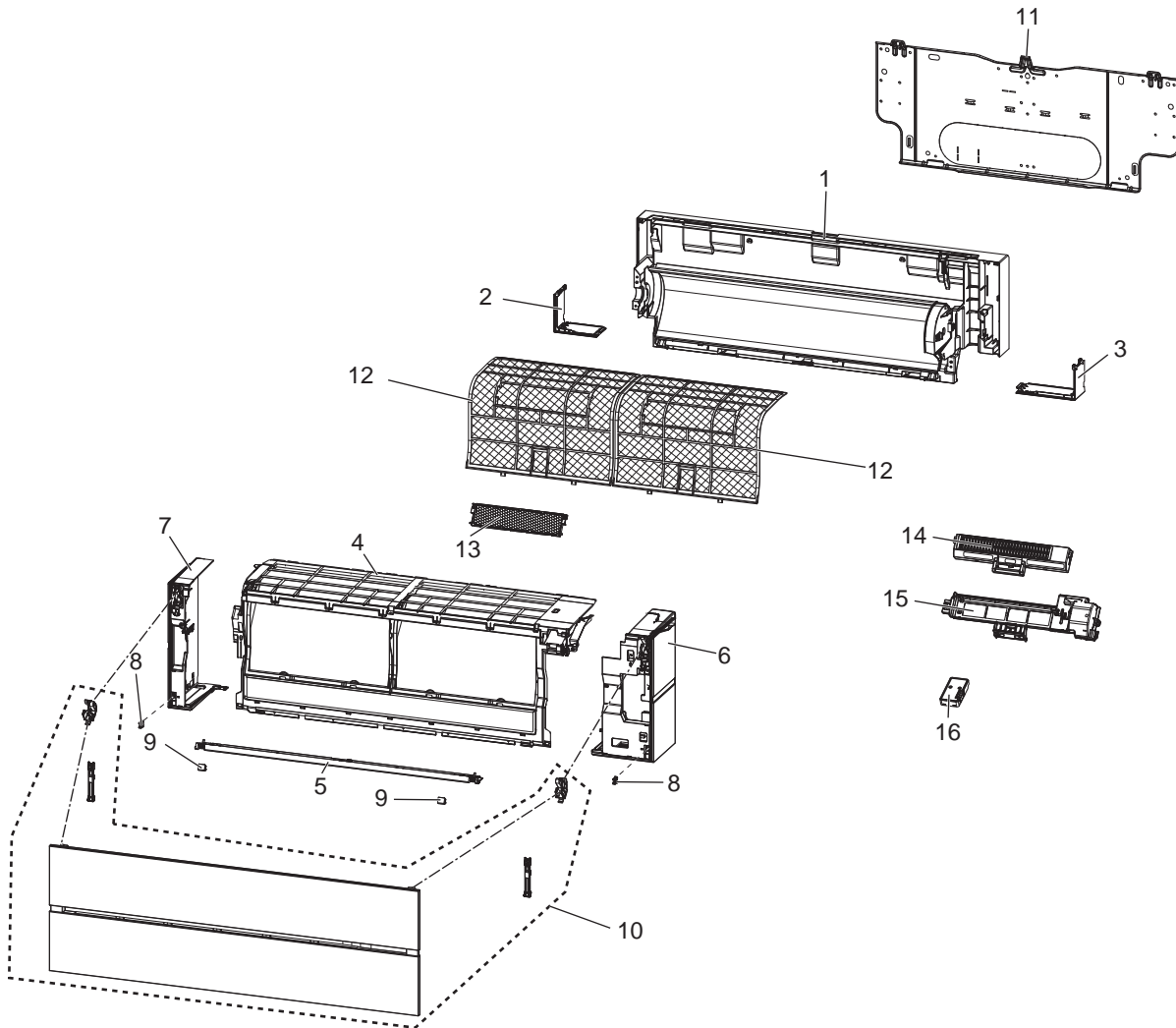

1-10. ACCESSORY AND REMOTE CONTROLLER



RoHS PARTS LIST

1-9. INDOOR UNIT STRUCTURAL PARTS

No.	RoHS	Part No.	Part name	Symbol in Wiring Diagram	Q'ty/unit								Remarks
					MSZ-LN								
					25				35				
					VGW -ER1	VGW -ER1	VGB -ER1	VGR -ER1	VGW -ER1	VGW -ER1	VGB -ER1	VGR -ER1	
1	G	E12 Y52 234	BOX ASSEMBLY		1	1			1	1			
	G	E12 Y60 234	BOX ASSEMBLY				1	1			1	1	
2	G	E12 Y52 976	CORNER BOX (L)		1	1			1	1			
	G	E12 Y60 976	CORNER BOX (L)				1	1			1	1	
3	G	E12 Y52 975	CORNER BOX (R)		1	1			1	1			
	G	E12 Y60 975	CORNER BOX (R)				1	1			1	1	
4	G	E12 Y52 000	PANEL ASSEMBLY (F)		1	1			1	1			
	G	E12 Y60 000	PANEL ASSEMBLY (F)				1	1			1	1	
5	G	E12 Y52 717	PANEL (U)		1	1			1	1			
	G	E12 Y60 717	PANEL (U)				1				1		
	G	E12 Y64 717	PANEL (U)				1					1	
6	G	E12 Y52 085	PANEL ASSEMBLY (R)		1				1				
	G	E12 Y56 085	PANEL ASSEMBLY (R)			1				1			
	G	E12 Y60 085	PANEL ASSEMBLY (R)				1				1		
	G	E12 Y64 085	PANEL ASSEMBLY (R)				1					1	
7	G	E12 Y52 086	PANEL ASSEMBLY (L)		1				1				
	G	E12 Y56 086	PANEL ASSEMBLY (L)			1				1			
	G	E12 Y60 086	PANEL ASSEMBLY (L)				1				1		
	G	E12 Y64 086	PANEL ASSEMBLY (L)				1					1	
8	G	E12 F95 142	CATCH		2	2	2	2	2	2	2	2	2 PCS/SET
9	G	E12 Y52 067	SCREW CAP		2	2			2	2			
	G	E12 Y60 067	SCREW CAP				2				2		
	G	E12 Y64 067	SCREW CAP				2					2	
10	G	E12 Y52 010	FRONT PANEL		1				1				
	G	E12 Y56 010	FRONT PANEL			1				1			
	G	E12 Y60 010	FRONT PANEL				1				1		
	G	E12 Y64 010	FRONT PANEL				1					1	
11	G	E12 Y52 970	INSTALLATION PLATE		1	1	1	1	1	1	1	1	
12	G	E12 Y52 100	AIR FILTER		2	2	2		2	2	2		1 PC/SET
	G	E12 Y64 100	AIR FILTER				2					2	1 PC/SET
13	G	-	AIR CLEANING FILTER (DEODORIZING FILTER)		1	1	1	1	1	1	1	1	1 PC/SET MAC-3010FT-E
14	G	E12 Y52 774	AIR PURIFYING DEVICE		1	1	1	1	1	1	1	1	
15	G	E12 Y52 775	AIR PURIFYING DEVICE SUPPORT		1	1	1	1	1	1	1	1	
16	G	E12 Y52 457	Wi-Fi INTERFACE MAC-567IFB-E		1	1	1	1	1	1	1	1	MAC-567IFB-E

1-10. ACCESSORY AND REMOTE CONTROLLER

No.	RoHS	Part No.	Part name	Symbol in Wiring Diagram	Q'ty/unit								Remarks
					MSZ-LN								
					25				35				
					VGW -ER1	VGW -ER1	VGB -ER1	VGR -ER1	VGW -ER1	VGW -ER1	VGB -ER1	VGR -ER1	
17	G	E12 Y52 426	REMOTE CONTROLLER		1				1				SG16L
	G	E12 Y56 426	REMOTE CONTROLLER			1				1			XG16A
	G	E12 Y60 426	REMOTE CONTROLLER				1				1		XG16C
	G	E12 Y64 426	REMOTE CONTROLLER				1					1	XG16B

RoHS PARTS LIST

MSZ-LN25VGW MSZ-LN25VGV MSZ-LN25VGB MSZ-LN25VGR
 MSZ-LN35VGW MSZ-LN35VGV MSZ-LN35VGB MSZ-LN35VGR
 1-11. INDOOR UNIT ELECTRICAL PARTS AND FUNCTIONAL PARTS

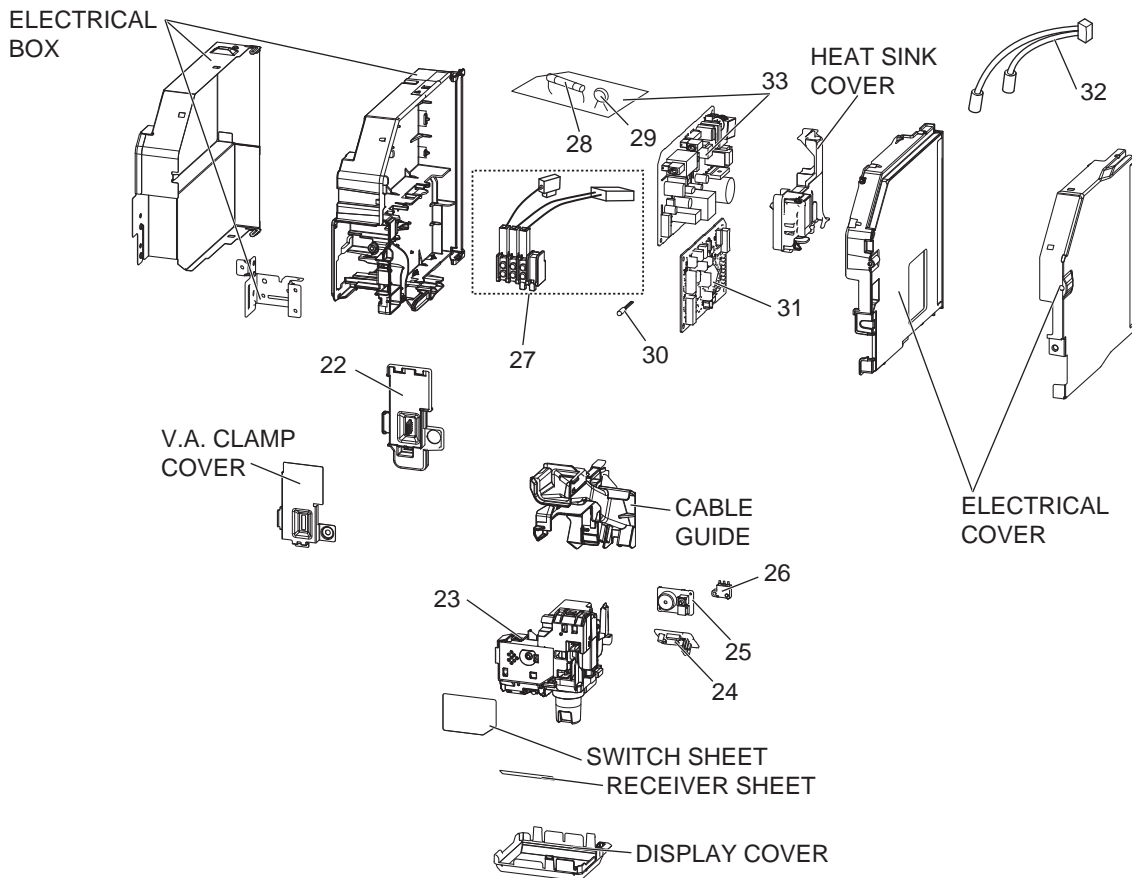
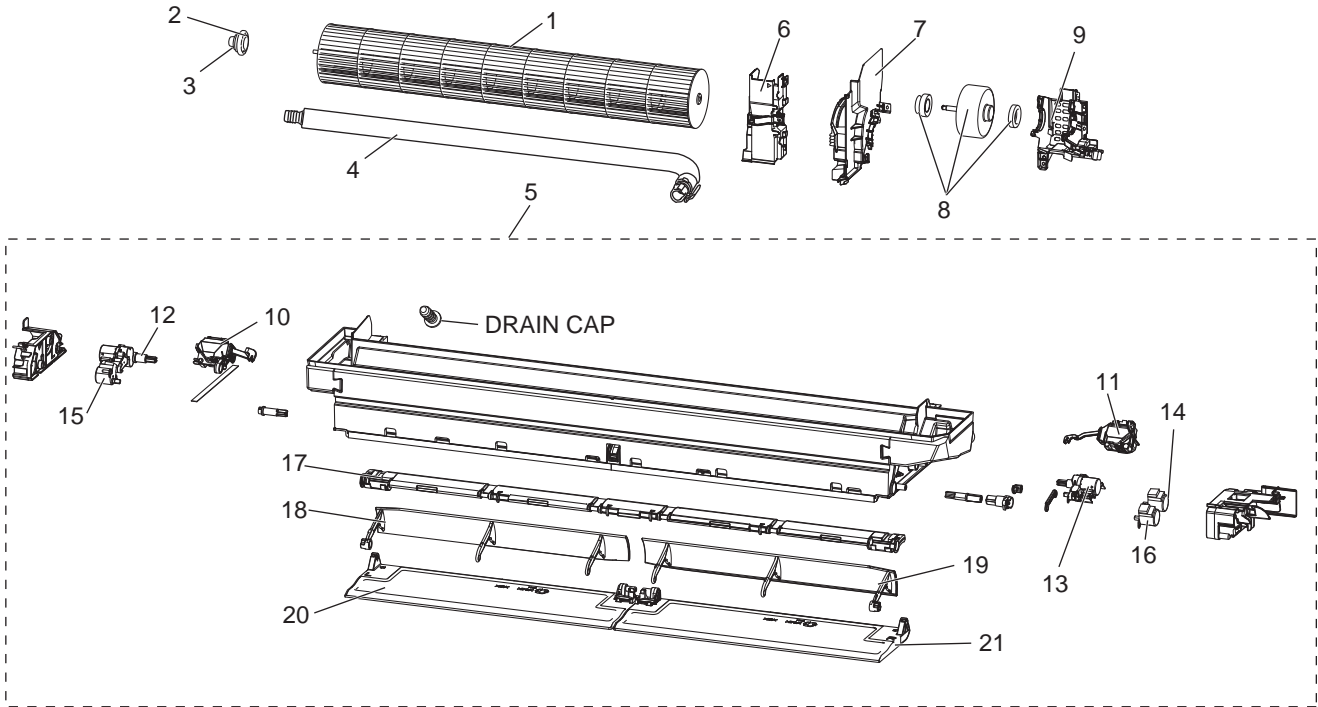

RoHS PARTS LIST

1-11. INDOOR UNIT ELECTRICAL PARTS AND FUNCTIONAL PARTS

No.	RoHS	Part No.	Part name	Symbol in Wiring Diagram	Q'ty/unit MSZ-LN								Remarks
					25				35				
					VGW -ER1	VGW -ER1	VGB -ER1	VGR -ER1	VGW -ER1	VGW -ER1	VGB -ER1	VGR -ER1	
1	G	E12 Y52 302	LINE FLOW FAN		1	1	1	1	1	1	1	1	
2	G	E12 001 504	SLEEVE BEARING		1	1	1	1	1	1	1	1	
3	G	E12 751 509	BEARING MOUNT		1	1	1	1	1	1	1	1	
4	G	E12 T20 702	DRAIN HOSE		1	1	1	1	1	1	1	1	
5	G	E12 Y52 235	NOZZLE ASSEMBLY		1	1			1	1			
	G	E12 Y60 235	NOZZLE ASSEMBLY				1				1		
	G	E12 Y64 235	NOZZLE ASSEMBLY					1				1	
6	G	E12 Y52 541	WATER COVER		1	1	1	1	1	1	1	1	
7	G	E12 Y52 333	MOTOR BAND		1	1	1	1	1	1	1	1	
8	G	E12 Y52 300	INDOOR FAN MOTOR	MF	1	1	1	1	1	1	1	1	RC0J30-□□
9	G	E12 20A 333	MOTOR BED		1	1	1	1	1	1	1	1	
10	G	E12 J44 303	VANE MOTOR (L) (VERTICAL)	MV2	1	1	1	1	1	1	1	1	(RIGHT & LEFT)
11	G	E12 J44 303	VANE MOTOR (R) (VERTICAL)	MV2	1	1	1	1	1	1	1	1	(RIGHT & LEFT)
12	G	E12 Y54 303	OUTER VANE MOTOR (L) (HORIZONTAL)	MV1	1	1	1	1	1	1	1	1	(UP & DOWN)
13	G	E12 Y53 303	OUTER VANE MOTOR (R) (HORIZONTAL)	MV1	1	1	1	1	1	1	1	1	(UP & DOWN)
14	G	E12 A89 303	VANE MOTOR (HORIZONTAL)	MV1	1	1	1	1	1	1	1	1	(UP & DOWN)
15	G	E12 A89 303	VANE MOTOR (L) (HORIZONTAL)	MV1	1	1	1	1	1	1	1	1	(UP & DOWN)
16	G	E12 A89 303	VANE MOTOR (R) (HORIZONTAL)	MV1	1	1	1	1	1	1	1	1	(UP & DOWN)
17	G	E12 Y52 046	VANE SLIDE ASSEMBLY		1	1			1	1			
	G	E12 Y60 046	VANE SLIDE ASSEMBLY				1	1			1	1	
18	G	E12 Y53 040	INNER VANE (L)		1	1	1	1	1	1	1	1	
19	G	E12 Y52 040	INNER VANE (R)		1	1	1	1	1	1	1	1	
20	G	E12 Y53 041	OUTER VANE (L)		1	1			1	1			
	G	E12 Y61 041	OUTER VANE (L)				1				1		
	G	E12 Y65 041	OUTER VANE (L)					1				1	
21	G	E12 Y52 041	OUTER VANE (R)		1	1			1	1			
	G	E12 Y60 041	OUTER VANE (R)				1				1		
	G	E12 Y64 041	OUTER VANE (R)					1				1	
22	G	E12 Y52 784	V.A. CLAMP		1	1	1	1	1	1	1	1	
23	G	E12 Y52 391	DISPLAY AND i-see SENSOR ASSEMBLY	MT	1	1			1	1			
	G	E12 Y60 391	DISPLAY AND i-see SENSOR ASSEMBLY	MT			1	1			1	1	
24	G	E12 Y52 468	DISPLAY AND RECEIVER P.C. BOARD		1	1	1	1	1	1	1	1	
26	G	E12 Y52 326	SWITCH BUZZER P.C. BOARD		1	1	1	1	1	1	1	1	
27	G	E12 Y52 316	INTER LOCK SWITCH (AIR PURIFYING DEVICE)		1	1	1	1	1	1	1	1	
28	G	E12 T21 375	TERMINAL BLOCK	TB	1	1	1	1	1	1	1	1	3P
29	G	E12 A49 382	FUSE	F11	1	1	1	1	1	1	1	1	T3.15AL250V
30	G	E12 B75 385	VARISTOR	NR11	1	1	1	1	1	1	1	1	
31	G	E12 Y52 308	ROOM TEMPERATURE THERMISTOR	RT11	1	1	1	1	1	1	1	1	
32	G	E12 Y52 452	ELECTRONIC CONTROL P.C. BOARD		1	1	1	1					
	G	E12 Y53 452	ELECTRONIC CONTROL P.C. BOARD						1	1	1	1	
33	G	E12 Y52 307	INDOOR COIL THERMISTOR	RT12, RT13	1	1	1	1	1	1	1	1	
	G	E12 Y52 440	POWER P.C. BOARD		1	1	1	1	1	1	1	1	

RoHS PARTS LIST

MSZ-LN25VGW MSZ-LN25VGV MSZ-LN25VGB MSZ-LN25VGR
MSZ-LN35VGW MSZ-LN35VGV MSZ-LN35VGB MSZ-LN35VGR
1-12. INDOOR UNIT HEAT EXCHANGER

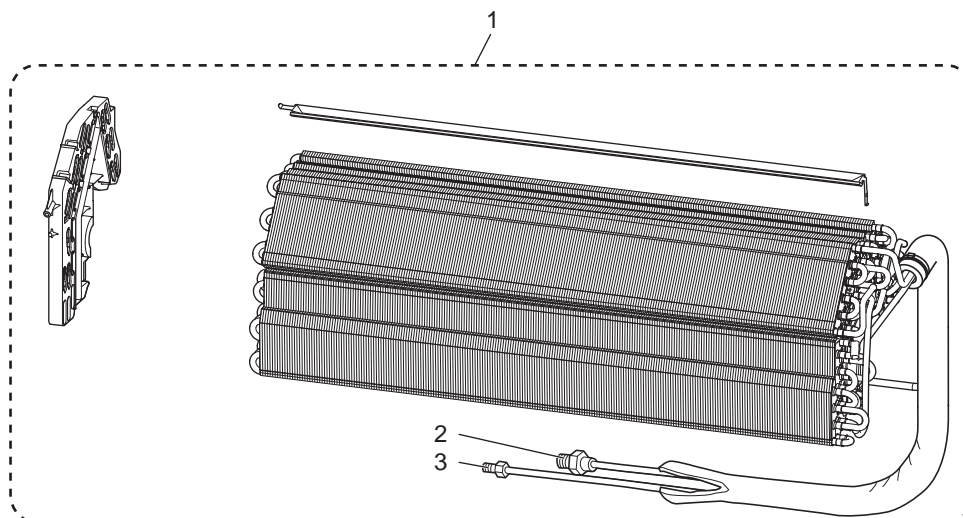

RoHS PARTS LIST

1-12. INDOOR UNIT HEAT EXCHANGER

No.	RoHS	Part No.	Part name	Symbol in Wiring Diagram	Q'ty/unit MSZ-LN								Remarks
					25				35				
					VGW -ER1	VGW -ER1	VGB -ER1	VGR -ER1	VGW -ER1	VGW -ER1	VGB -ER1	VGR -ER1	
1	G	E12 Y52 620	INDOOR HEAT EXCHANGER		1	1	1	1	1	1	1	1	
2	G	E12 815 666	UNION (GAS)		1	1	1	1	1	1	1	1	ø9.52
3	G	E12 151 667	UNION (LIQUID)		1	1	1	1	1	1	1	1	ø6.35

RoHS PARTS LIST

MSZ-LN50VGW MSZ-LN50VGV MSZ-LN50VGB MSZ-LN50VGR
MSZ-LN60VGW MSZ-LN60VGV MSZ-LN60VGB MSZ-LN60VGR

1-13. INDOOR UNIT STRUCTURAL PARTS

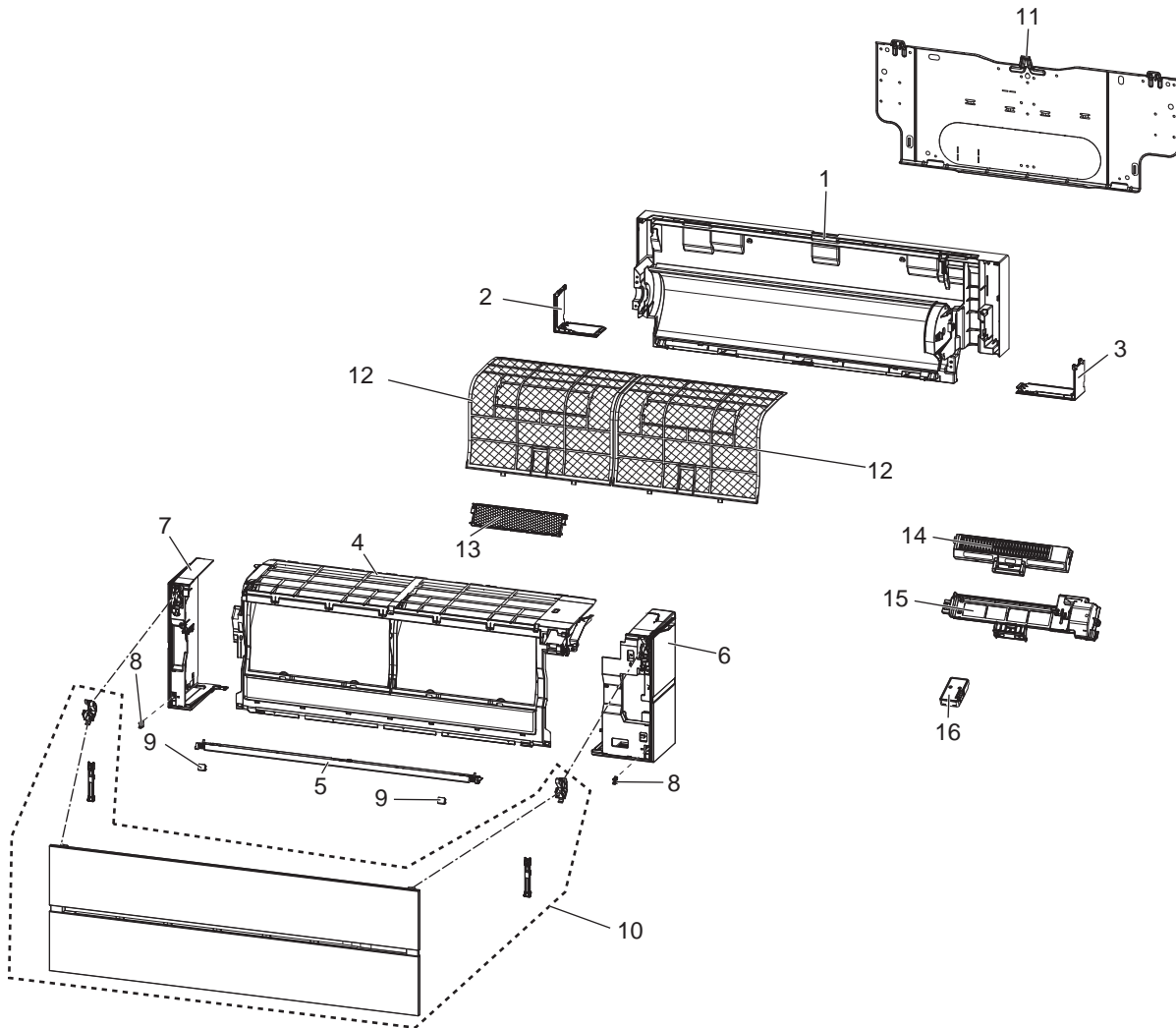

1-14. ACCESSORY AND REMOTE CONTROLLER



RoHS PARTS LIST

1-13. INDOOR UNIT STRUCTURAL PARTS

No.	RoHS	Part No.	Part name	Symbol in Wiring Diagram	Q'ty/unit								Remarks	
					MSZ-LN									
					50				60					
VGW	VGW	VGB	VGR	VGW	VGW	VGB	VGR							
-E1	-E1	-E1	-E1	-E1	-E1	-E1	-E1	-E1	-E1					
1	G	E12 Y52 234	BOX ASSEMBLY		1	1			1	1				
	G	E12 Y60 234	BOX ASSEMBLY				1	1			1	1		
2	G	E12 Y52 976	CORNER BOX (L)		1	1			1	1				
	G	E12 Y60 976	CORNER BOX (L)				1	1			1	1		
3	G	E12 Y52 975	CORNER BOX (R)		1	1			1	1				
	G	E12 Y60 975	CORNER BOX (R)				1	1			1	1		
4	G	E12 Y52 000	PANEL ASSEMBLY (F)		1	1			1	1				
	G	E12 Y60 000	PANEL ASSEMBLY (F)				1	1			1	1		
5	G	E12 Y52 717	PANEL (U)		1	1			1	1				
	G	E12 Y60 717	PANEL (U)				1				1			
	G	E12 Y64 717	PANEL (U)				1					1		
6	G	E12 Y52 085	PANEL ASSEMBLY (R)		1				1					
	G	E12 Y56 085	PANEL ASSEMBLY (R)			1				1				
	G	E12 Y60 085	PANEL ASSEMBLY (R)				1				1			
	G	E12 Y64 085	PANEL ASSEMBLY (R)				1					1		
7	G	E12 Y52 086	PANEL ASSEMBLY (L)		1				1					
	G	E12 Y56 086	PANEL ASSEMBLY (L)			1				1				
	G	E12 Y60 086	PANEL ASSEMBLY (L)				1				1			
	G	E12 Y64 086	PANEL ASSEMBLY (L)				1					1		
8	G	E12 F95 142	CATCH		2	2	2	2	2	2	2	2	2	2 PCS/SET
9	G	E12 Y52 067	SCREW CAP		2	2			2	2				
	G	E12 Y60 067	SCREW CAP				2				2			
	G	E12 Y64 067	SCREW CAP				2					2		
10	G	E12 Y52 010	FRONT PANEL		1				1					
	G	E12 Y56 010	FRONT PANEL			1				1				
	G	E12 Y60 010	FRONT PANEL				1				1			
	G	E12 Y64 010	FRONT PANEL				1					1		
11	G	E12 Y52 970	INSTALLATION PLATE		1	1	1	1	1	1	1	1		
12	G	E12 Y52 100	AIR FILTER		2	2	2		2	2	2			1 PC/SET
12	G	E12 Y64 100	AIR FILTER				2					2		1 PC/SET
13	G	-	AIR CLEANING FILTER (DEODORIZING FILTER)		1	1	1	1	1	1	1	1		1 PC/SET MAC-3010FT-E
14	G	E12 Y52 774	AIR PURIFYING DEVICE		1	1	1	1	1	1	1	1		
15	G	E12 Y52 775	AIR PURIFYING DEVICE SUPPORT		1	1	1	1	1	1	1	1		
16	G	E12 Y52 457	Wi-Fi INTERFACE MAC-567IFB-E		1	1	1	1	1	1	1	1		MAC-567IFB-E

1-14. ACCESSORY AND REMOTE CONTROLLER

No.	RoHS	Part No.	Part name	Symbol in Wiring Diagram	Q'ty/unit								Remarks	
					MSZ-LN									
					50				60					
VGW	VGW	VGB	VGR	VGW	VGW	VGB	VGR							
-E1	-E1	-E1	-E1	-E1	-E1	-E1	-E1	-E1	-E1					
17	G	E12 Y52 426	REMOTE CONTROLLER		1				1					SG16L
	G	E12 Y56 426	REMOTE CONTROLLER			1				1				XG16A
	G	E12 Y60 426	REMOTE CONTROLLER				1				1			XG16C
	G	E12 Y64 426	REMOTE CONTROLLER				1					1		XG16B

RoHS PARTS LIST

MSZ-LN50VGW MSZ-LN50VGV MSZ-LN50VGB MSZ-LN50VGR
 MSZ-LN60VGW MSZ-LN60VGV MSZ-LN60VGB MSZ-LN60VGR
 1-15. INDOOR UNIT ELECTRICAL PARTS AND FUNCTIONAL PARTS

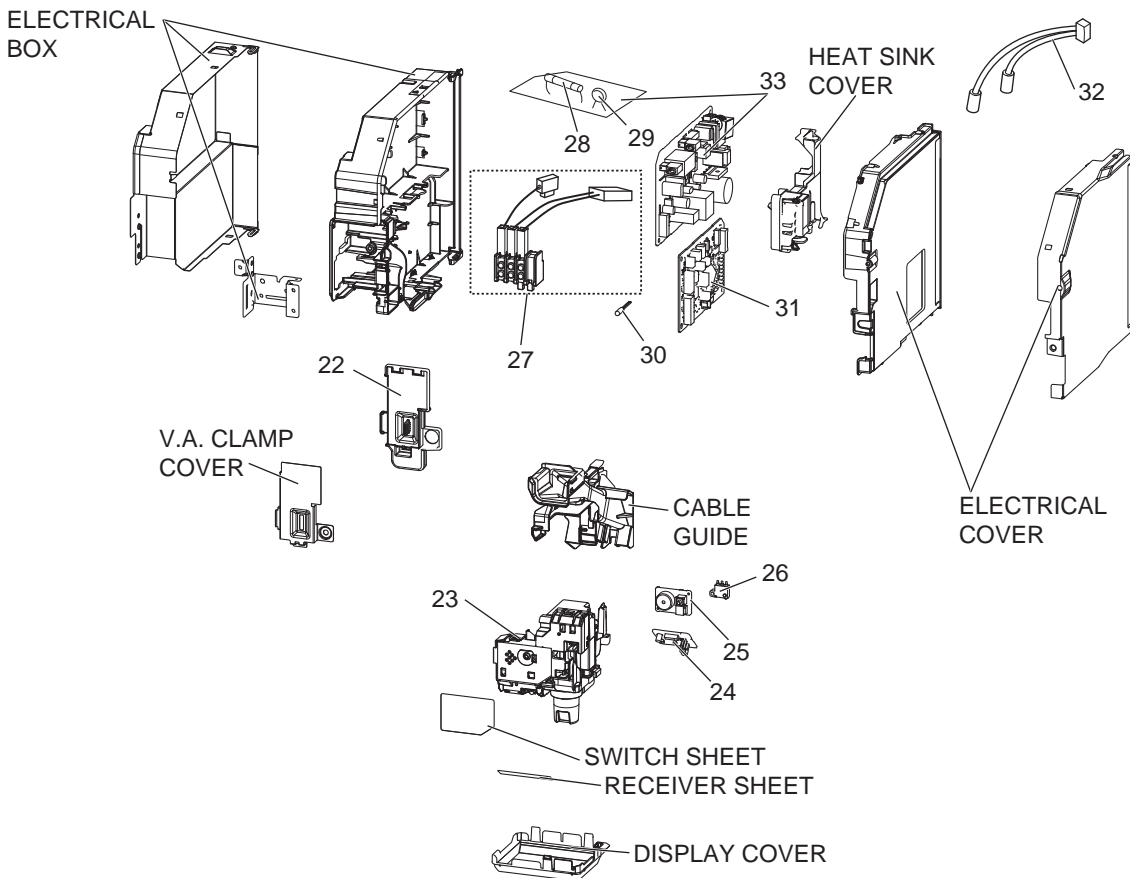
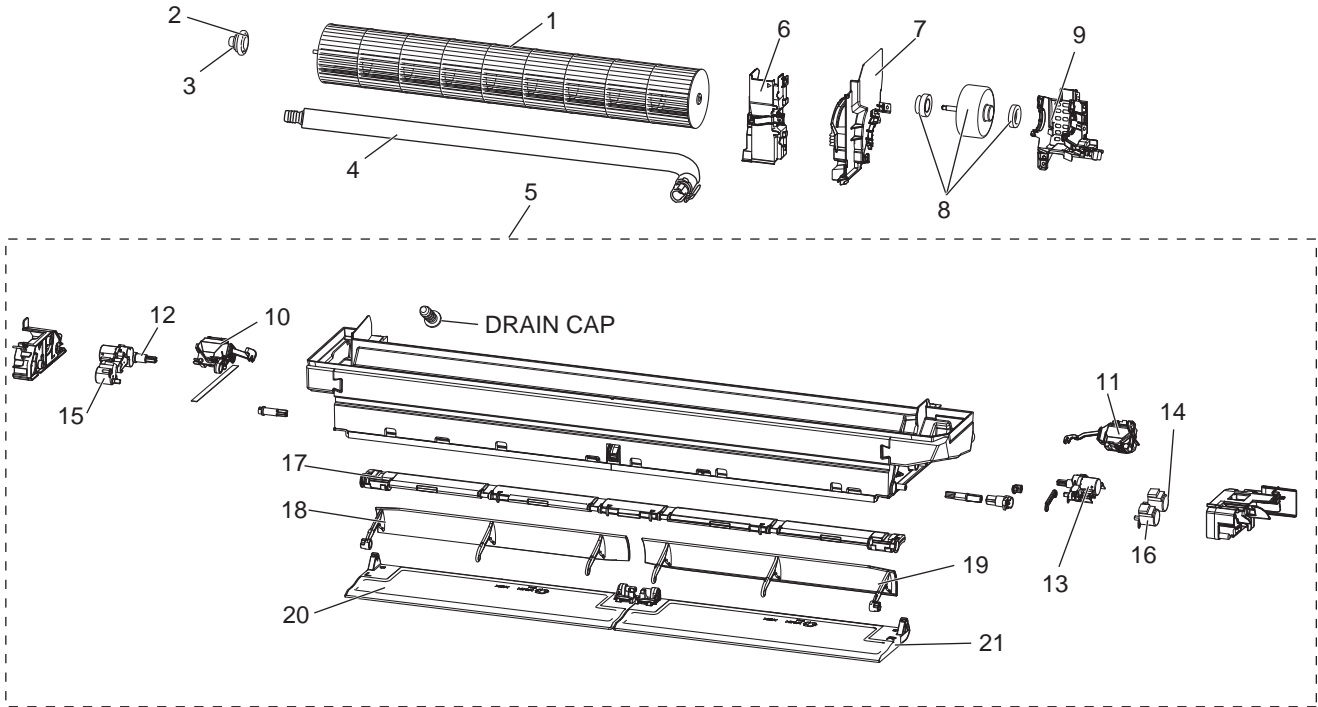

RoHS PARTS LIST

1-15. INDOOR UNIT ELECTRICAL PARTS AND FUNCTIONAL PARTS

No.	RoHS	Part No.	Part name	Symbol in Wiring Diagram	Q'ty/unit MSZ-LN								Remarks
					50				60				
					VGW -E1	VGW -E1	VGB -E1	VGR -E1	VGW -E1	VGW -E1	VGB -E1	VGR -E1	
1	G	E12 Y52 302	LINE FLOW FAN		1	1	1	1	1	1	1	1	
2	G	E12 001 504	SLEEVE BEARING		1	1	1	1	1	1	1	1	
3	G	E12 751 509	BEARING MOUNT		1	1	1	1	1	1	1	1	
4	G	E12 T20 702	DRAIN HOSE		1	1	1	1	1	1	1	1	
5	G	E12 Y52 235	NOZZLE ASSEMBLY		1	1			1	1			
	G	E12 Y60 235	NOZZLE ASSEMBLY				1				1		
	G	E12 Y64 235	NOZZLE ASSEMBLY					1				1	
6	G	E12 Y52 541	WATER COVER		1	1	1	1	1	1	1	1	
7	G	E12 Y52 333	MOTOR BAND		1	1	1	1	1	1	1	1	
8	G	E12 Y52 300	INDOOR FAN MOTOR	MF	1	1	1	1	1	1	1	1	RC0J30-□□
9	G	E12 20A 333	MOTOR BED		1	1	1	1	1	1	1	1	
10	G	E12 J44 303	VANE MOTOR (L) (VERTICAL)	MV2	1	1	1	1	1	1	1	1	(RIGHT & LEFT)
11	G	E12 J44 303	VANE MOTOR (R) (VERTICAL)	MV2	1	1	1	1	1	1	1	1	(RIGHT & LEFT)
12	G	E12 Y54 303	OUTER VANE MOTOR (L) (HORIZONTAL)	MV1	1	1	1	1	1	1	1	1	(UP & DOWN)
13	G	E12 Y53 303	OUTER VANE MOTOR (R) (HORIZONTAL)	MV1	1	1	1	1	1	1	1	1	(UP & DOWN)
14	G	E12 A89 303	VANE MOTOR (HORIZONTAL)	MV1	1	1	1	1	1	1	1	1	(UP & DOWN)
15	G	E12 A89 303	VANE MOTOR (L) (HORIZONTAL)	MV1	1	1	1	1	1	1	1	1	(UP & DOWN)
16	G	E12 A89 303	VANE MOTOR (R) (HORIZONTAL)	MV1	1	1	1	1	1	1	1	1	(UP & DOWN)
17	G	E12 Y52 046	VANE SLIDE ASSEMBLY		1	1			1	1			
	G	E12 Y60 046	VANE SLIDE ASSEMBLY				1	1			1	1	
18	G	E12 Y53 040	INNER VANE (L)		1	1	1	1	1	1	1	1	
19	G	E12 Y52 040	INNER VANE (R)		1	1	1	1	1	1	1	1	
20	G	E12 Y53 041	OUTER VANE (L)		1	1			1	1			
	G	E12 Y61 041	OUTER VANE (L)				1				1		
	G	E12 Y65 041	OUTER VANE (L)					1				1	
21	G	E12 Y52 041	OUTER VANE (R)		1	1			1	1			
	G	E12 Y60 041	OUTER VANE (R)				1				1		
	G	E12 Y64 041	OUTER VANE (R)					1				1	
22	G	E12 Y52 784	V.A. CLAMP		1	1	1	1	1	1	1	1	
23	G	E12 Y52 391	DISPLAY AND i-see SENSOR ASSEMBLY	MT	1	1			1	1			
	G	E12 Y60 391	DISPLAY AND i-see SENSOR ASSEMBLY	MT			1	1			1	1	
24	G	E12 Y52 468	DISPLAY AND RECEIVER P.C. BOARD		1	1	1	1	1	1	1	1	
25	G	E12 Y52 326	SWITCH BUZZER P.C. BOARD		1	1	1	1	1	1	1	1	
26	G	E12 Y52 316	INTER LOCK SWITCH (AIR PURIFYING DEVICE)		1	1	1	1	1	1	1	1	
27	G	E12 T21 375	TERMINAL BLOCK	TB	1	1	1	1	1	1	1	1	3P
28	G	E12 A49 382	FUSE	F11	1	1	1	1	1	1	1	1	T3.15AL250V
29	G	E12 B75 385	VARISTOR	NR11	1	1	1	1	1	1	1	1	
30	G	E12 Y52 308	ROOM TEMPERATURE THERMISTOR	RT11	1	1	1	1	1	1	1	1	
31	G	E12 Y54 452	ELECTRONIC CONTROL P.C. BOARD		1	1	1	1					
	G	E12 Y55 452	ELECTRONIC CONTROL P.C. BOARD						1	1	1	1	
32	G	E12 Y54 307	INDOOR COIL THERMISTOR	RT12, RT13	1	1	1	1	1	1	1	1	
33	G	E12 Y54 440	POWER P.C. BOARD		1	1	1	1					
	G	E12 Y55 440	POWER P.C. BOARD						1	1	1	1	

RoHS PARTS LIST

MSZ-LN50VGW MSZ-LN50VGV MSZ-LN50VGB MSZ-LN50VGR

MSZ-LN60VGW MSZ-LN60VGV MSZ-LN60VGB MSZ-LN60VGR

1-16. INDOOR UNIT HEAT EXCHANGER

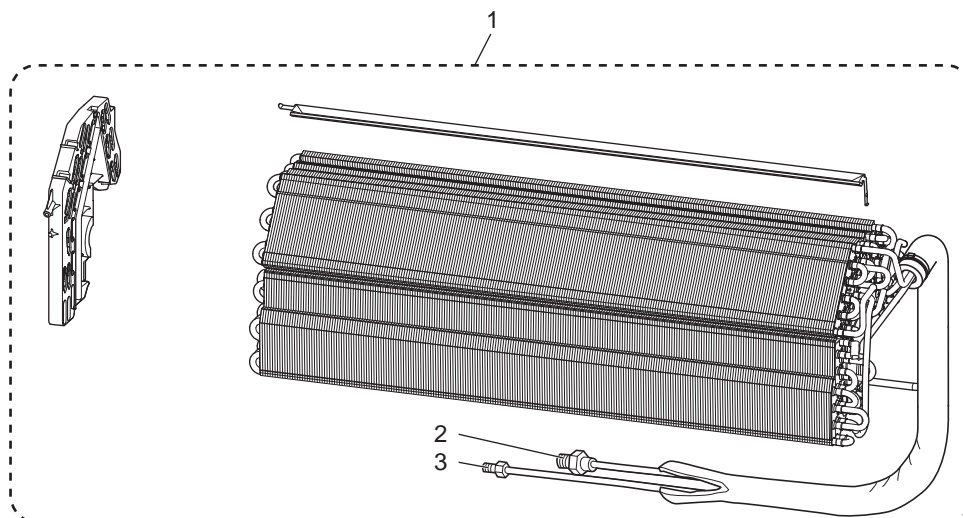

RoHS PARTS LIST

1-16. INDOOR UNIT HEAT EXCHANGER

No.	RoHS	Part No.	Part name	Symbol in Wiring Diagram	Q'ty/unit								Remarks			
					MSZ-LN											
					50				60							
VGW	VGW	VGV	VGV	VGB	VGB	VGR	VGR	VGW	VGW	VGV	VGV	VGB	VGB	VGR	VGR	
1	G	E12 Y54 620	INDOOR HEAT EXCHANGER		1	1	1	1								
	G	E12 Y55 620	INDOOR HEAT EXCHANGER						1	1	1	1				
2	G	E12 815 666	UNION (GAS)		1	1	1	1							ø9.52	
	G	E12 155 666	UNION (GAS)						1	1	1	1			ø12.7	
3	G	E12 151 667	UNION (LIQUID)		1	1	1	1	1	1	1	1			ø6.35	

RoHS PARTS LIST

MSZ-LN50VGW MSZ-LN50VGV MSZ-LN50VGB MSZ-LN50VGR
MSZ-LN60VGW MSZ-LN60VGV MSZ-LN60VGB MSZ-LN60VGR

1-17. INDOOR UNIT STRUCTURAL PARTS

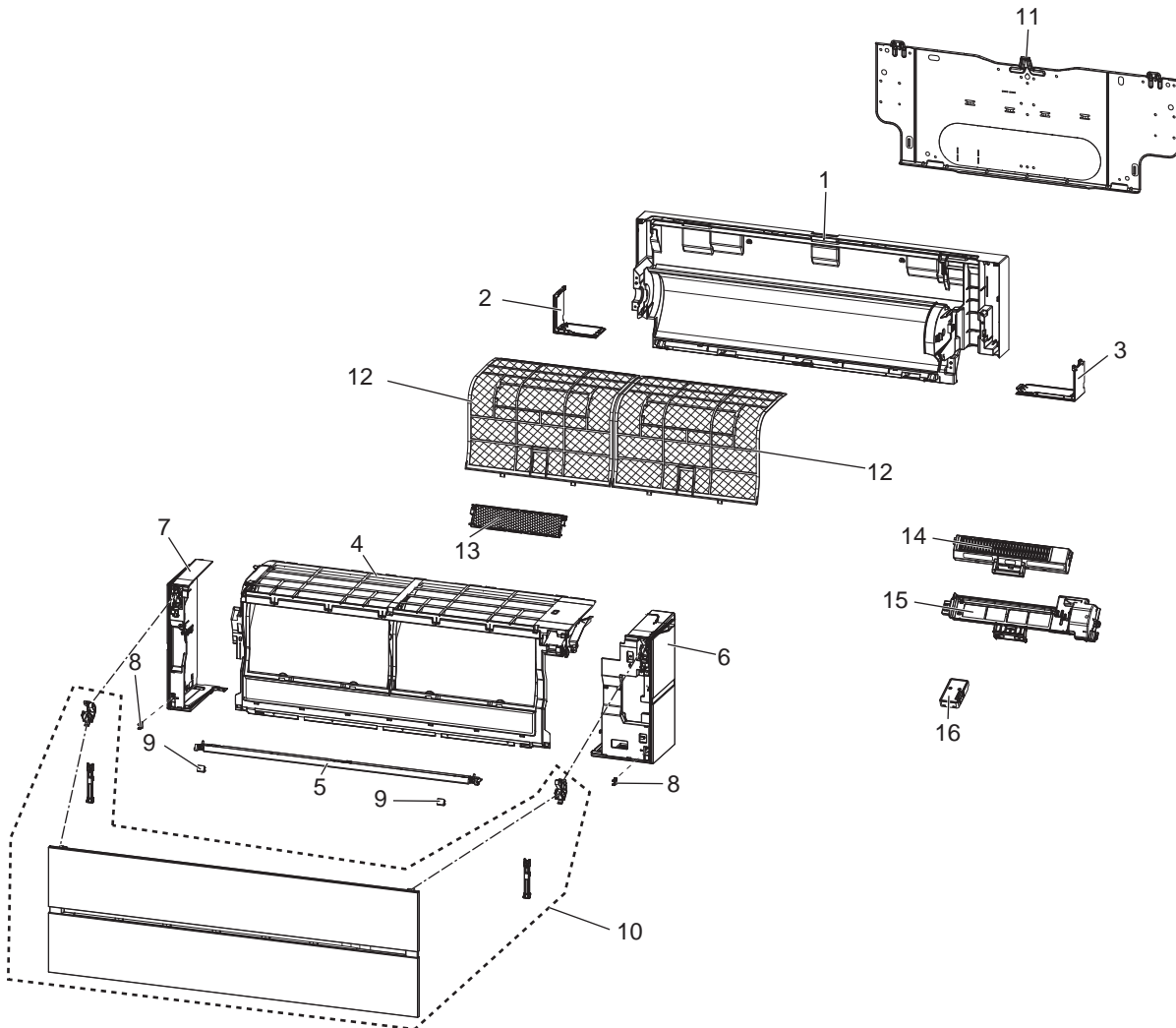

1-18. ACCESSORY AND REMOTE CONTROLLER



RoHS PARTS LIST

1-17. INDOOR UNIT STRUCTURAL PARTS

No.	RoHS	Part No.	Part name	Symbol in Wiring Diagram	Q'ty/unit								Remarks
					MSZ-LN								
					50				60				
					VGW -ER1	VGW -ER1	VGB -ER1	VGR -ER1	VGW -ER1	VGW -ER1	VGB -ER1	VGR -ER1	
1	G	E12 Y52 234	BOX ASSEMBLY		1	1			1	1			
	G	E12 Y60 234	BOX ASSEMBLY				1	1			1	1	
2	G	E12 Y52 976	CORNER BOX (L)		1	1			1	1			
	G	E12 Y60 976	CORNER BOX (L)				1	1			1	1	
3	G	E12 Y52 975	CORNER BOX (R)		1	1			1	1			
	G	E12 Y60 975	CORNER BOX (R)				1	1			1	1	
4	G	E12 Y52 000	PANEL ASSEMBLY (F)		1	1			1	1			
	G	E12 Y60 000	PANEL ASSEMBLY (F)				1	1			1	1	
5	G	E12 Y52 717	PANEL (U)		1	1			1	1			
	G	E12 Y60 717	PANEL (U)				1				1		
	G	E12 Y64 717	PANEL (U)				1					1	
6	G	E12 Y52 085	PANEL ASSEMBLY (R)		1				1				
	G	E12 Y56 085	PANEL ASSEMBLY (R)			1				1			
	G	E12 Y60 085	PANEL ASSEMBLY (R)				1				1		
	G	E12 Y64 085	PANEL ASSEMBLY (R)				1					1	
7	G	E12 Y52 086	PANEL ASSEMBLY (L)		1				1				
	G	E12 Y56 086	PANEL ASSEMBLY (L)			1				1			
	G	E12 Y60 086	PANEL ASSEMBLY (L)				1				1		
	G	E12 Y64 086	PANEL ASSEMBLY (L)				1					1	
8	G	E12 F95 142	CATCH		2	2	2	2	2	2	2	2	2 PCS/SET
9	G	E12 Y52 067	SCREW CAP		2	2			2	2			
	G	E12 Y60 067	SCREW CAP				2				2		
	G	E12 Y64 067	SCREW CAP				2					2	
10	G	E12 Y52 010	FRONT PANEL		1				1				
	G	E12 Y56 010	FRONT PANEL			1				1			
	G	E12 Y60 010	FRONT PANEL				1				1		
	G	E12 Y64 010	FRONT PANEL				1					1	
11	G	E12 Y52 970	INSTALLATION PLATE		1	1	1	1	1	1	1	1	
12	G	E12 Y52 100	AIR FILTER		2	2	2		2	2	2		1 PC/SET
	G	E12 Y64 100	AIR FILTER				2					2	1 PC/SET
13	G	-	AIR CLEANING FILTER (DEODORIZING FILTER)		1	1	1	1	1	1	1	1	1 PC/SET MAC-3010FT-E
14	G	E12 Y52 774	AIR PURIFYING DEVICE		1	1	1	1	1	1	1	1	
15	G	E12 Y52 775	AIR PURIFYING DEVICE SUPPORT		1	1	1	1	1	1	1	1	
16	G	E12 Y52 457	Wi-Fi INTERFACE MAC-567IFB-E		1	1	1	1	1	1	1	1	MAC-567IFB-E

1-18. ACCESSORY AND REMOTE CONTROLLER

No.	RoHS	Part No.	Part name	Symbol in Wiring Diagram	Q'ty/unit								Remarks
					MSZ-LN								
					50				60				
					VGW -ER1	VGW -ER1	VGB -ER1	VGR -ER1	VGW -ER1	VGW -ER1	VGB -ER1	VGR -ER1	
17	G	E12 Y52 426	REMOTE CONTROLLER		1				1				SG16L
	G	E12 Y56 426	REMOTE CONTROLLER			1				1			XG16A
	G	E12 Y60 426	REMOTE CONTROLLER				1				1		XG16C
	G	E12 Y64 426	REMOTE CONTROLLER				1					1	XG16B

RoHS PARTS LIST

MSZ-LN50VGW MSZ-LN50VGV MSZ-LN50VGB MSZ-LN50VGR
 MSZ-LN60VGW MSZ-LN60VGV MSZ-LN60VGB MSZ-LN60VGR
 1-19. INDOOR UNIT ELECTRICAL PARTS AND FUNCTIONAL PARTS

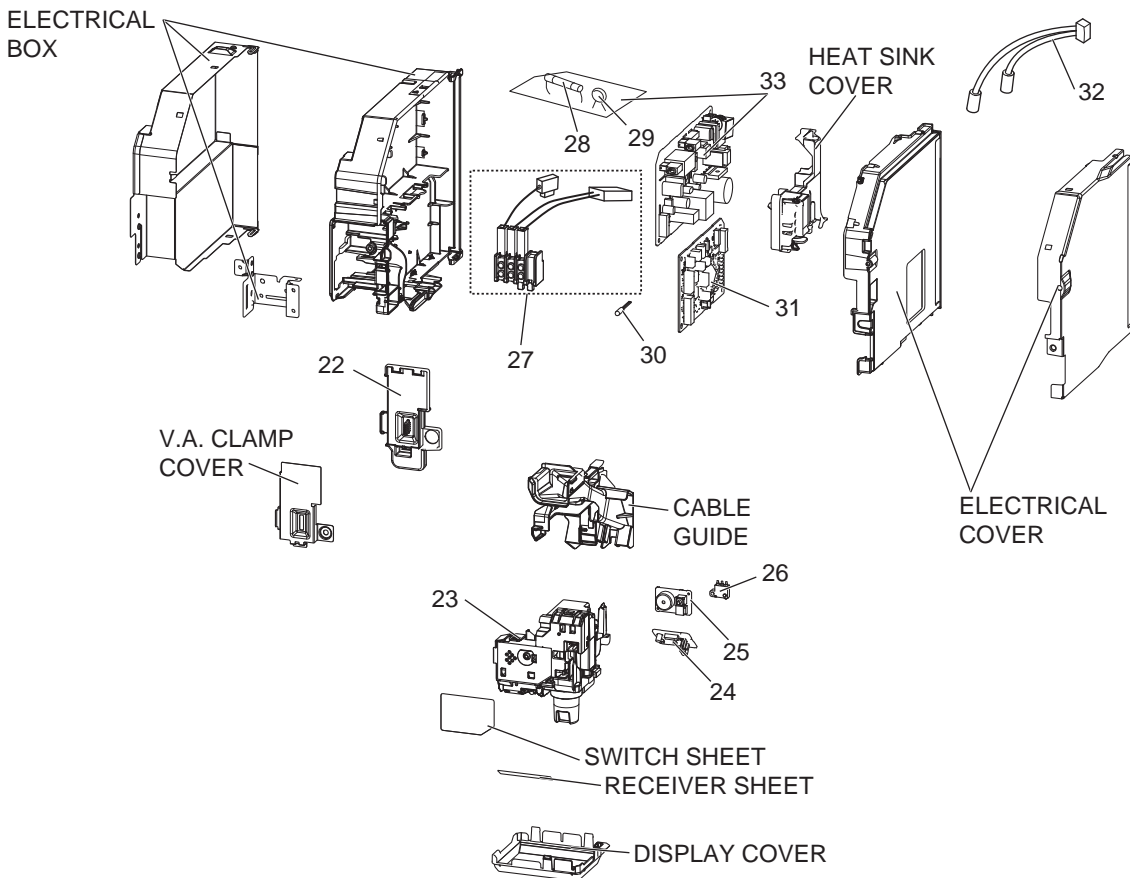
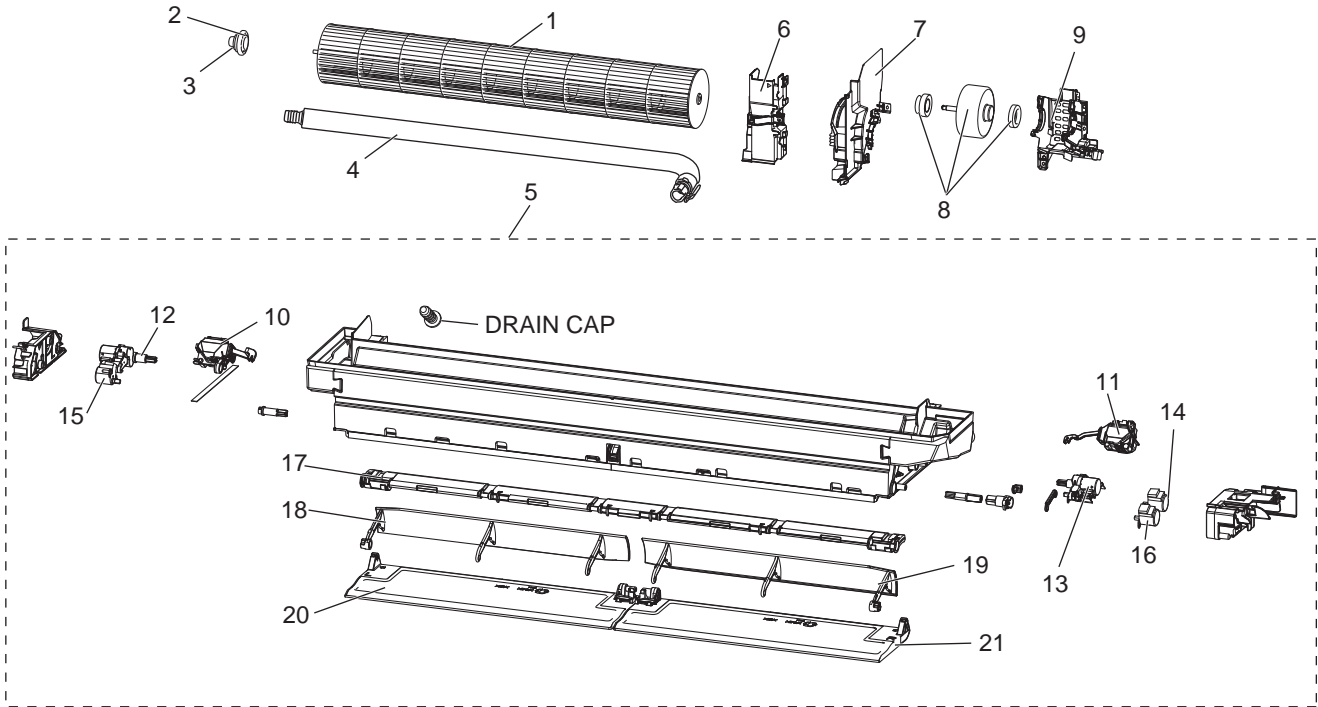

RoHS PARTS LIST

1-19. INDOOR UNIT ELECTRICAL PARTS AND FUNCTIONAL PARTS

No.	RoHS	Part No.	Part name	Symbol in Wiring Diagram	Q'ty/unit MSZ-LN								Remarks
					50				60				
					VGW -ER1	VGW -ER1	VGB -ER1	VGR -ER1	VGW -ER1	VGW -ER1	VGB -ER1	VGR -ER1	
1	G	E12 Y52 302	LINE FLOW FAN		1	1	1	1	1	1	1	1	
2	G	E12 001 504	SLEEVE BEARING		1	1	1	1	1	1	1	1	
3	G	E12 751 509	BEARING MOUNT		1	1	1	1	1	1	1	1	
4	G	E12 T20 702	DRAIN HOSE		1	1	1	1	1	1	1	1	
5	G	E12 Y52 235	NOZZLE ASSEMBLY		1	1			1	1			
	G	E12 Y60 235	NOZZLE ASSEMBLY				1				1		
	G	E12 Y64 235	NOZZLE ASSEMBLY					1				1	
6	G	E12 Y52 541	WATER COVER		1	1	1	1	1	1	1	1	
7	G	E12 Y52 333	MOTOR BAND		1	1	1	1	1	1	1	1	
8	G	E12 Y52 300	INDOOR FAN MOTOR	MF	1	1	1	1	1	1	1	1	RC0J30-□□
9	G	E12 20A 333	MOTOR BED		1	1	1	1	1	1	1	1	
10	G	E12 J44 303	VANE MOTOR (L) (VERTICAL)	MV2	1	1	1	1	1	1	1	1	(RIGHT & LEFT)
11	G	E12 J44 303	VANE MOTOR (R) (VERTICAL)	MV2	1	1	1	1	1	1	1	1	(RIGHT & LEFT)
12	G	E12 Y54 303	OUTER VANE MOTOR (L) (HORIZONTAL)	MV1	1	1	1	1	1	1	1	1	(UP & DOWN)
13	G	E12 Y53 303	OUTER VANE MOTOR (R) (HORIZONTAL)	MV1	1	1	1	1	1	1	1	1	(UP & DOWN)
14	G	E12 A89 303	VANE MOTOR (HORIZONTAL)	MV1	1	1	1	1	1	1	1	1	(UP & DOWN)
15	G	E12 A89 303	VANE MOTOR (L) (HORIZONTAL)	MV1	1	1	1	1	1	1	1	1	(UP & DOWN)
16	G	E12 A89 303	VANE MOTOR (R) (HORIZONTAL)	MV1	1	1	1	1	1	1	1	1	(UP & DOWN)
17	G	E12 Y52 046	VANE SLIDE ASSEMBLY		1	1			1	1			
	G	E12 Y60 046	VANE SLIDE ASSEMBLY				1	1			1	1	
18	G	E12 Y53 040	INNER VANE (L)		1	1	1	1	1	1	1	1	
19	G	E12 Y52 040	INNER VANE (R)		1	1	1	1	1	1	1	1	
20	G	E12 Y53 041	OUTER VANE (L)		1	1			1	1			
	G	E12 Y61 041	OUTER VANE (L)				1				1		
	G	E12 Y65 041	OUTER VANE (L)					1				1	
21	G	E12 Y52 041	OUTER VANE (R)		1	1			1	1			
	G	E12 Y60 041	OUTER VANE (R)				1				1		
	G	E12 Y64 041	OUTER VANE (R)					1				1	
22	G	E12 Y52 784	V.A. CLAMP		1	1	1	1	1	1	1	1	
23	G	E12 Y52 391	DISPLAY AND i-see SENSOR ASSEMBLY	MT	1	1			1	1			
	G	E12 Y60 391	DISPLAY AND i-see SENSOR ASSEMBLY	MT			1	1			1	1	
24	G	E12 Y52 468	DISPLAY AND RECEIVER P.C. BOARD		1	1	1	1	1	1	1	1	
25	G	E12 Y52 326	SWITCH BUZZER P.C. BOARD		1	1	1	1	1	1	1	1	
26	G	E12 Y52 316	INTER LOCK SWITCH (AIR PURIFYING DEVICE)		1	1	1	1	1	1	1	1	
27	G	E12 T21 375	TERMINAL BLOCK	TB	1	1	1	1	1	1	1	1	3P
28	G	E12 A49 382	FUSE	F11	1	1	1	1	1	1	1	1	T3.15AL250V
29	G	E12 B75 385	VARISTOR	NR11	1	1	1	1	1	1	1	1	
30	G	E12 Y52 308	ROOM TEMPERATURE THERMISTOR	RT11	1	1	1	1	1	1	1	1	
31	G	E12 Y54 452	ELECTRONIC CONTROL P.C. BOARD		1	1	1	1					
	G	E12 Y55 452	ELECTRONIC CONTROL P.C. BOARD						1	1	1	1	
32	G	E12 Y54 307	INDOOR COIL THERMISTOR	RT12, RT13	1	1	1	1	1	1	1	1	
33	G	E12 Y54 440	POWER P.C. BOARD		1	1	1	1					
	G	E12 Y55 440	POWER P.C. BOARD						1	1	1	1	

RoHS PARTS LIST

MSZ-LN50VGW MSZ-LN50VGV MSZ-LN50VGB MSZ-LN50VGR
 MSZ-LN60VGW MSZ-LN60VGV MSZ-LN60VGB MSZ-LN60VGR
 1-20. INDOOR UNIT HEAT EXCHANGER

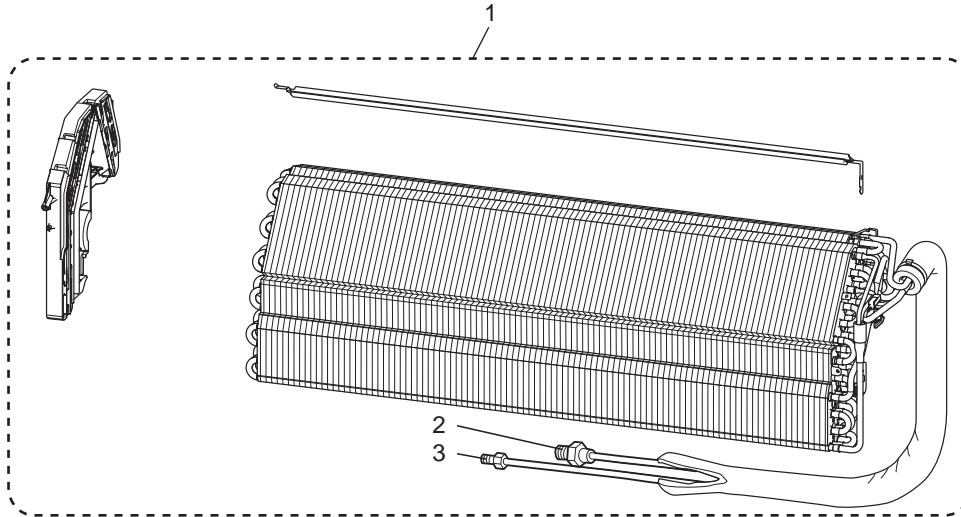

No.	RoHS	Part No.	Part name	Symbol in Wiring Diagram	Q'ty/unit								Remarks
					MSZ-LN								
					50				60				
VGW -ER1	VGW -ER1	VGB -ER1	VGR -ER1	VGW -ER1	VGV -ER1	VGB -ER1	VGR -ER1						
1	G	E12 Y54 620	INDOOR HEAT EXCHANGER		1	1	1	1					
	G	E12 Y55 620	INDOOR HEAT EXCHANGER					1	1	1	1		
2	G	E12 815 666	UNION (GAS)		1	1	1	1					ø9.52
	G	E12 155 666	UNION (GAS)					1	1	1	1		ø12.7
3	G	E12 151 667	UNION (LIQUID)		1	1	1	1	1	1	1	1	ø6.35

RoHS PARTS LIST

1-21. AIR PURIFYING DEVICE

Every 3 months:

- Remove dirt by a vacuum cleaner.

When dirt cannot be removed by vacuum cleaning:

- Soak the filter together with its frame in lukewarm water and rinse it.
- After washing, dry it well in shade.

NOTE 1: The air purifying device does not function for safety for a couple minutes after the operation starts or the front panel is opened/closed.

NOTE 2: Do not disassemble the air purifying device.

NOTE 3: Do not touch any parts other than the frame of the air purifying device.

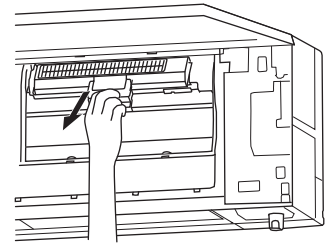

1-22. AIR CLEANING FILTER

[DEODORIZING FILTER (BLACK)]

Every 3 months:

- Remove dirt by a vacuum cleaner, or soak the framed filter in lukewarm water (30 to 40 °C) for about 15 minutes. Rinse well.
- After washing, dry it well in shade.
- Deodorizing feature recovers by cleaning the filter.

When dirt or smell cannot be removed by cleaning:

- Replace it with a new air cleaning filter.

NOTE 1: Clean the filters regularly for best performance and to reduce power consumption.

NOTE 2: Dirty filters cause condensation in the air conditioner which will contribute to the growth of fungi such as mold. It is therefore recommended to clean air filters every 2 weeks.

Model	Part No.
MSZ-LN18VGW	MAC-3010FT-E
MSZ-LN18VGV	
MSZ-LN18VGB	
MSZ-LN18VGR	
MSZ-LN25VGW	
MSZ-LN25VGV	
MSZ-LN25VGB	
MSZ-LN25VGR	
MSZ-LN35VGW	
MSZ-LN35VGV	
MSZ-LN35VGB	
MSZ-LN35VGR	
MSZ-LN50VGW	
MSZ-LN50VGV	
MSZ-LN50VGB	
MSZ-LN50VGR	
MSZ-LN60VGW	
MSZ-LN60VGV	
MSZ-LN60VGB	
MSZ-LN60VGR	

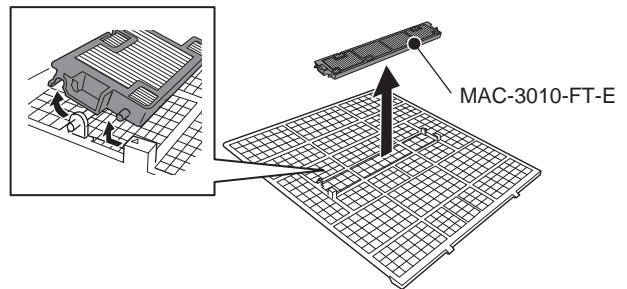

2-1. AIR CLEANING FILTER

[SILVER-IONIZED AIR PURIFIER FILTER, OPTION (BLUE)]**Every 3 months:**

- Remove dirt by a vacuum cleaner.

When dirt cannot be removed by vacuum cleaning:

- Soak the filter and its frame in lukewarm water before rinsing it.
- After washing, dry it well in shade. Install all tabs of the air filter.

Every year:

- Replace it with a new air cleaning filter for best performance.

NOTE 1: Clean the filters regularly for best performance and to reduce power consumption.

NOTE 2: Dirty filters cause condensation in the air conditioner which will contribute to the growth of fungi such as mold. It is therefore recommended to clean air filters every 2 weeks.

Model	Part No.
MSZ-LN18VGW	MAC-2390FT-E
MSZ-LN18VGV	
MSZ-LN18VGB	
MSZ-LN18VGR	
MSZ-LN25VGW	
MSZ-LN25VGV	
MSZ-LN25VGB	
MSZ-LN25VGR	
MSZ-LN35VGW	
MSZ-LN35VGV	
MSZ-LN35VGB	
MSZ-LN35VGR	
MSZ-LN50VGW	
MSZ-LN50VGV	
MSZ-LN50VGB	
MSZ-LN50VGR	
MSZ-LN60VGW	
MSZ-LN60VGV	
MSZ-LN60VGB	
MSZ-LN60VGR	

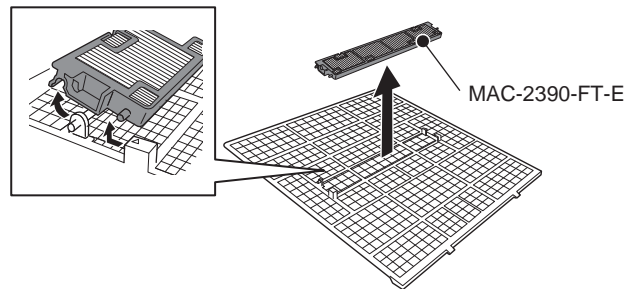

MITSUBISHI ELECTRIC CORPORATION

HEAD OFFICE: TOKYO BUILDING, 2-7-3, MARUNOUCHI, CHIYODA-KU, TOKYO 100-8310, JAPAN

© Copyright 2016 MITSUBISHI ELECTRIC CORPORATION

Issued: Mar. 2018. No. OBB766 REVISED EDITION-A

Published: Dec. 2016. No. OBB766

Made in Japan

Specifications are subject to change without notice.