

# SERVICE PARTS LIST FOR MITSUBISHI ELECTRIC PACKAGED AIR-CONDITIONERS

Series : PUHY-P·Y(S)KB-A1.TH(-BS)

For use with the R410A

REVISED

Sept. 2015

BWE01430B

## INDEX

PUHY-P200YKB-A1.TH  
PUHY-P200YKB-A1.TH-BS  
PUHY-P250YKB-A1.TH  
PUHY-P250YKB-A1.TH-BS  
PUHY-P300YKB-A1.TH  
PUHY-P300YKB-A1.TH-BS  
PUHY-P350YKB-A1.TH  
PUHY-P350YKB-A1.TH-BS  
PUHY-P400YKB-A1.TH  
PUHY-P400YKB-A1.TH-BS  
PUHY-P450YKB-A1.TH  
PUHY-P450YKB-A1.TH-BS  
PUHY-P500YKB-A1.TH  
PUHY-P500YKB-A1.TH-BS

Refer to the next page for the package names.

Part information update day : 2015/09/14

Please change the old catalog (issued Apr. 2015, No.BWE01430A) to this new catalog.  
Content of revision : Some of parts are changed.



## The Package name list

**PUHY-P400YSKB-A1(-BS)** [PUHY-P200YKB-A1.TH(-BS)+PUHY-P200YKB-A1.TH(-BS)]

**PUHY-P450YSKB-A1(-BS)** [PUHY-P200YKB-A1.TH(-BS)+PUHY-P250YKB-A1.TH(-BS)]

**PUHY-P500YSKB-A1(-BS)** [PUHY-P250YKB-A1.TH(-BS)+PUHY-P250YKB-A1.TH(-BS)]

**PUHY-P550YSKB-A1(-BS)** [PUHY-P250YKB-A1.TH(-BS)+PUHY-P300YKB-A1.TH(-BS)]

**PUHY-P600YSKB-A1(-BS)** [PUHY-P250YKB-A1.TH(-BS)+PUHY-P350YKB-A1.TH(-BS)]

**PUHY-P650YSKB-A1(-BS)** [PUHY-P300YKB-A1.TH(-BS)+PUHY-P350YKB-A1.TH(-BS)]

**PUHY-P700YSKB-A1(-BS)** [PUHY-P350YKB-A1.TH(-BS)+PUHY-P350YKB-A1.TH(-BS)]

**PUHY-P750YSKB-A1(-BS)** [PUHY-P350YKB-A1.TH(-BS)+PUHY-P400YKB-A1.TH(-BS)]

**PUHY-P800YSKB-A1(-BS)** [PUHY-P350YKB-A1.TH(-BS)+PUHY-P450YKB-A1.TH(-BS)]

**PUHY-P850YSKB-A1(-BS)** [PUHY-P400YKB-A1.TH(-BS)+PUHY-P450YKB-A1.TH(-BS)]

**PUHY-P900YSKB-A1(-BS)** [PUHY-P450YKB-A1.TH(-BS)+PUHY-P450YKB-A1.TH(-BS)]

**PUHY-P950YSKB-A1(-BS)** [PUHY-P250YKB-A1.TH(-BS)+PUHY-P300YKB-A1.TH(-BS)+PUHY-P400YKB-A1.TH(-BS)]

**PUHY-P1000YSKB-A1(-BS)** [PUHY-P300YKB-A1.TH(-BS)+PUHY-P300YKB-A1.TH(-BS)+PUHY-P400YKB-A1.TH(-BS)]

**PUHY-P1050YSKB-A1(-BS)** [PUHY-P300YKB-A1.TH(-BS)+PUHY-P350YKB-A1.TH(-BS)+PUHY-P400YKB-A1.TH(-BS)]

**PUHY-P1100YSKB-A1(-BS)** [PUHY-P350YKB-A1.TH(-BS)+PUHY-P350YKB-A1.TH(-BS)+PUHY-P400YKB-A1.TH(-BS)]

**PUHY-P1150YSKB-A1(-BS)** [PUHY-P350YKB-A1.TH(-BS)+PUHY-P350YKB-A1.TH(-BS)+PUHY-P450YKB-A1.TH(-BS)]

**PUHY-P1200YSKB-A1(-BS)** [PUHY-P350YKB-A1.TH(-BS)+PUHY-P400YKB-A1.TH(-BS)+PUHY-P450YKB-A1.TH(-BS)]

**PUHY-P1250YSKB-A1(-BS)** [PUHY-P350YKB-A1.TH(-BS)+PUHY-P450YKB-A1.TH(-BS)+PUHY-P450YKB-A1.TH(-BS)]

**PUHY-P1300YSKB-A1(-BS)** [PUHY-P400YKB-A1.TH(-BS)+PUHY-P450YKB-A1.TH(-BS)+PUHY-P450YKB-A1.TH(-BS)]

**PUHY-P1350YSKB-A1(-BS)** [PUHY-P450YKB-A1.TH(-BS)+PUHY-P450YKB-A1.TH(-BS)+PUHY-P450YKB-A1.TH(-BS)]

PUHY-P200,P250YKB-A1.TH  
 PUHY-P200,P250YKB-A1.TH-BS

EXTERNAL PARTS & BLOWER PARTS (1)

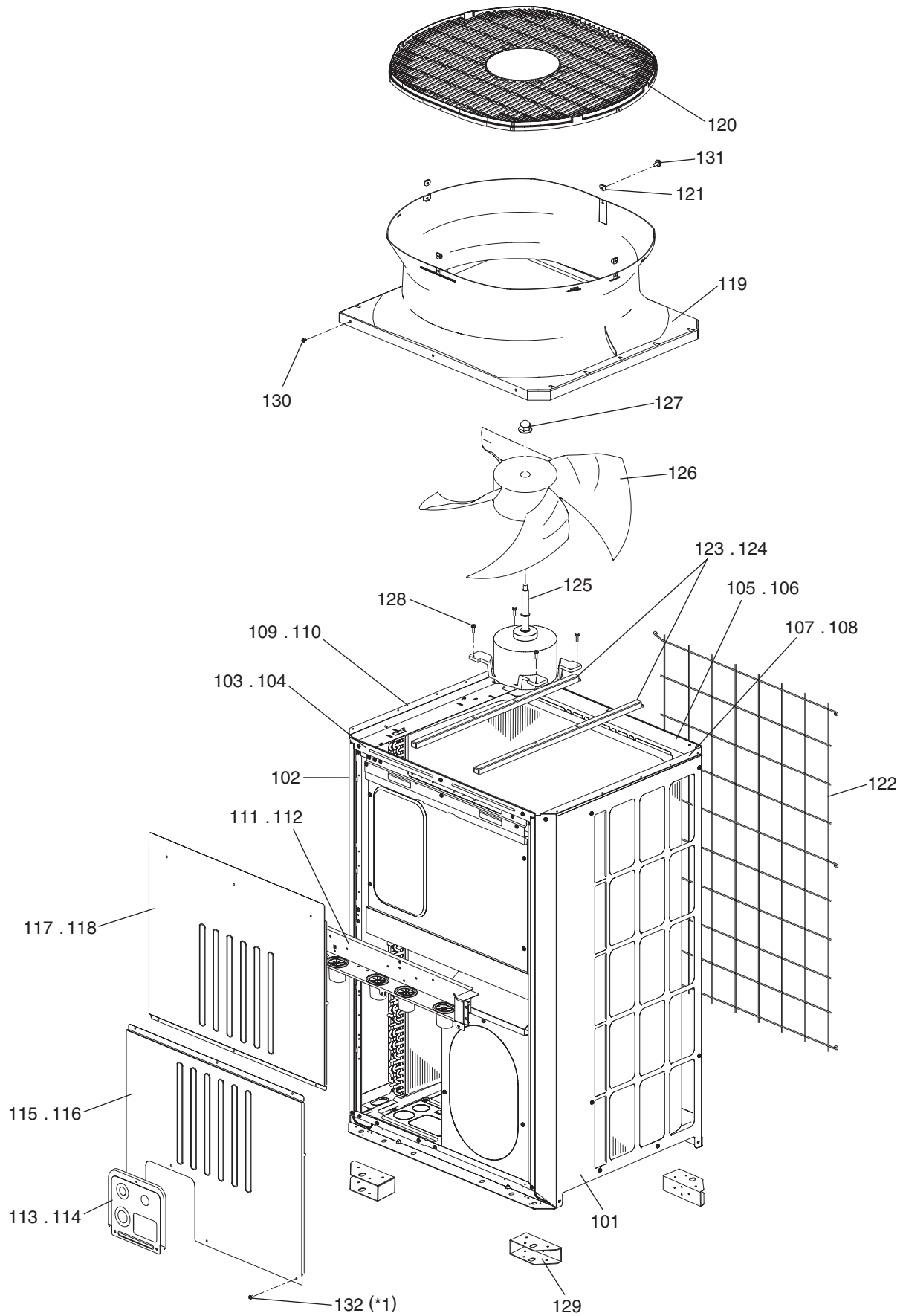

\*1 PUHY-P200YKB-A1.TH(-BS)···111 PCS/UNIT  
 PUHY-P250YKB-A1.TH(-BS)···112 PCS/UNIT

No.	Part No.	Part Name	Spec.	PUHY-P200YKB-A1.TH	PUHY-P200YKB-A1.TH-BS	PUHY-P250YKB-A1.TH	PUHY-P250YKB-A1.TH-BS	Dwg. No.	Notes for the models	Revision info.
				G : RoHS Apply Only W : RoHS Apply by Running Change						
101	E17 A59 085	G Panel R		1	1	1	1	KJ00C589G05		
102	E17 A59 086	G Panel L		1	1	1	1	KJ00C588G05		
103	E17 981 256	G Frame F		1		1		KB02N696G01		
104	E17 989 256	G Frame F	BS		1	1		KJ00C611G01		
105	E17 A59 255	G Frame assy B		1		1		KJ00C608G03		
106	E17 A66 255	G Frame assy B	BS		1	1		KJ00C608G04		
107	E17 A59 254	G Frame assy LR		1		1		KJ00L905G01		
108	E17 A66 254	G Frame assy LR	BS		1	1		KJ00L905G02		
109	E17 A59 253	G Frame assy L		1		1		KJ00L906G01		
110	E17 A66 253	G Frame assy L	BS		1	1		KJ00L906G02		
111	E17 981 257	G Frame assy M		1		1		KJ00C636G01		
112	E17 989 257	G Frame assy M	BS		1	1		KJ00C636G02		
113	E17 630 910	G Pipe cover		1		1		KB00P794G01		
114	E17 631 910	G Pipe cover	BS		1	1		KB00P794G02		
115	E17 982 232	G Panel FB		1		1		KJ00C665G03		
116	E17 990 232	G Panel FB	BS		1	1		KJ00C665G04		
117	E17 981 232	G Panel FU		1		1		KJ00C664G03		
118	E17 989 232	G Panel FU	BS		1	1		KJ00C664G04		
119	E17 981 509	G Bell mouth		1	1	1	1	KB25A620G01		
120	E17 981 521	G Fan guard		1	1	1	1	KB25A623G03		
121	E17 981 810	G Plate fanguard		4	4	4	4	KD02K443G01		
122	E17 A59 523	G Fin guard B		1	1	1	1	KB07V113G02		
123	E17 981 290	G Fan stand		2		2		KD02K465G01		
124	E17 989 290	G Fan stand	BS		2	2		KD00K588G01		
125	E17 981 301	G Outdoor fan motor	L-MW-920-B4-1	1	1	1	1	KR61C257H02		
126	E17 622 501	G Propeller fan		1	1	1	1	KB25A284H02		
127	E17 622 508	G Cap nut	M12	1	1	1	1	KB12S220H02		
128	E17 982 250	G Screw upset	M6×22	10	10	10	10	KB12S261H02	4PCS/UNIT	
129	KD00M720G03	G Attachment leg		4	4	4	4	KD00M720G03		
130	E17 633 250	G Screw	M5×12	20	20	20	20	KB12S217H01	12PCS/UNIT	
131	E17 983 250	G Screw	M5×16	10	10	10	10	KB12S217H02	4PCS/UNIT	
132	E17 623 250	G Screw	M5×10 KNURLED	20	20	20	20	KB12S216H01	*1	

PUHY-P300,P350,P400YKB-A1.TH  
PUHY-P300,P350,P400YKB-A1.TH-BS

EXTERNAL PARTS & BLOWER PARTS (2)

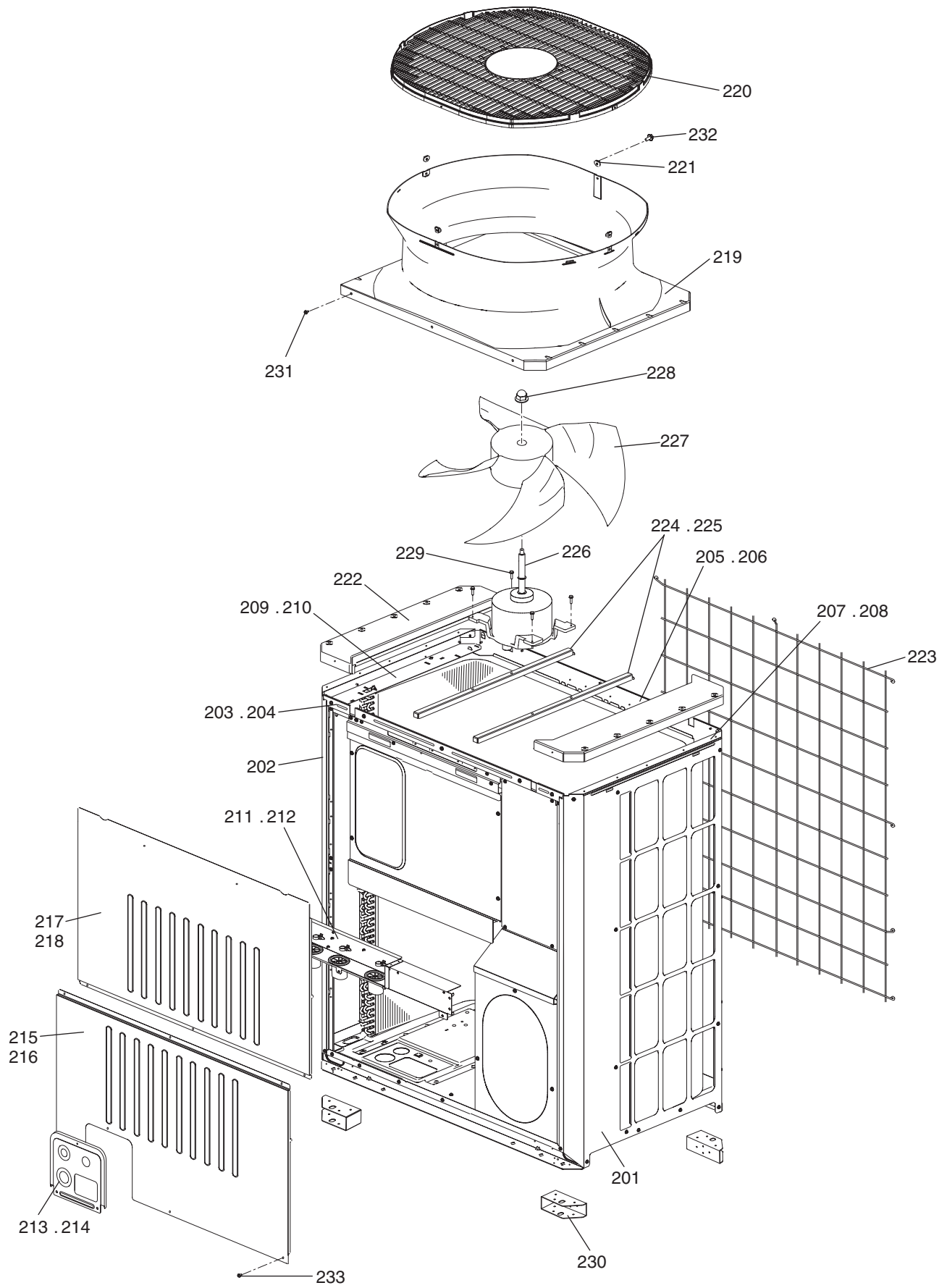

PUHY-P300,P350,P400YKB-A1.TH  
 PUHY-P300,P350,P400YKB-A1.TH-BS

EXTERNAL PARTS & BLOWER PARTS (2)

No.	Part No.	G : RoHS Apply Only W : RoHS Apply by Running Change	Spec.							Dwg. No.	Notes for the models	Revision info.
				PUHY-P300YKB-A1.TH	PUHY-P300YKB-A1.TH-BS	PUHY-P350YKB-A1.TH	PUHY-P350YKB-A1.TH-BS	PUHY-P400YKB-A1.TH	PUHY-P400YKB-A1.TH-BS			
Part Name												
201	E17 A59 085	G	Panel R	1	1	1	1	1	1	KJ00C589G05		
202	E17 A59 086	G	Panel L	1	1	1	1	1	1	KJ00C588G05		
203	E17 984 256	G	Frame F	1		1		1		KB02N697G01		
204	E17 992 256	G	Frame F		1		1		1	KJ00C612G01		
205	E17 984 255	G	Frame assy B	1		1		1		KJ00C609G03		
206	E17 992 255	G	Frame assy B		1		1		1	KJ00C609G04		
207	E17 A59 254	G	Frame assy LR	1		1		1		KJ00L905G01		
208	E17 A66 254	G	Frame assy LR		1		1		1	KJ00L905G02		
209	E17 A59 253	G	Frame assy L	1		1		1		KJ00L906G01		
210	E17 A66 253	G	Frame assy L		1		1		1	KJ00L906G02		
211	E17 A61 257	G	Frame assy M	1		1		1		KJ00C637G05		
212	E17 A68 257	G	Frame assy M		1		1		1	KJ00C637G06		
213	E17 630 910	G	Pipe cover	1		1		1		KB00P794G01		
214	E17 631 910	G	Pipe cover		1		1		1	KB00P794G02		
215	E17 985 232	G	Panel FB	1		1		1		KJ00C667G03		
216	E17 993 232	G	Panel FB		1		1		1	KJ00C667G04		
217	E17 984 232	G	Panel FU	1		1		1		KJ00C666G03		
218	E17 992 232	G	Panel FU		1		1		1	KJ00C666G04		
219	E17 981 509	G	Bell mouth	1	1	1	1	1	1	KB25A620G01		
220	E17 981 521	G	Fan guard	1	1	1	1	1	1	KB25A623G03		
221	E17 981 810	G	Plate fanguard	4	4	4	4	4	4	KD02K443G01		
222	E17 984 532	G	Cover fanguard	2	2	2	2	2	2	KJ00G367G01		
223	E17 A61 523	G	Fin guard B	1	1	1	1	1	1	KB07N807G02		
224	E17 981 290	G	Fan stand	2		2		2		KD02K465G01		
225	E17 989 290	G	Fan stand		2		2		2	KD00K588G01		
226	E17 981 301	G	Outdoor fan motor	1	1	1	1	1	1	KR61C257H02		
227	E17 622 501	G	Propeller fan	1	1	1	1	1	1	KB25A284H02		
228	E17 622 508	G	Cap nut	1	1	1	1	1	1	KB12S220H02		
229	E17 982 250	G	Screw upset	10	10	10	10	10	10	KB12S261H02	4PCS/UNIT	
230	KD00M720G03	G	Attachment leg	4	4	4	4	4	4	KD00M720G03		
231	E17 633 250	G	Screw	20	20	20	20	20	20	KB12S217H01	19PCS/UNIT	
232	E17 983 250	G	Screw	10	10	10	10	10	10	KB12S217H02	4PCS/UNIT	
233	E17 623 250	G	Screw	20	20	20	20	20	20	KB12S216H01	115PCS/UNIT	

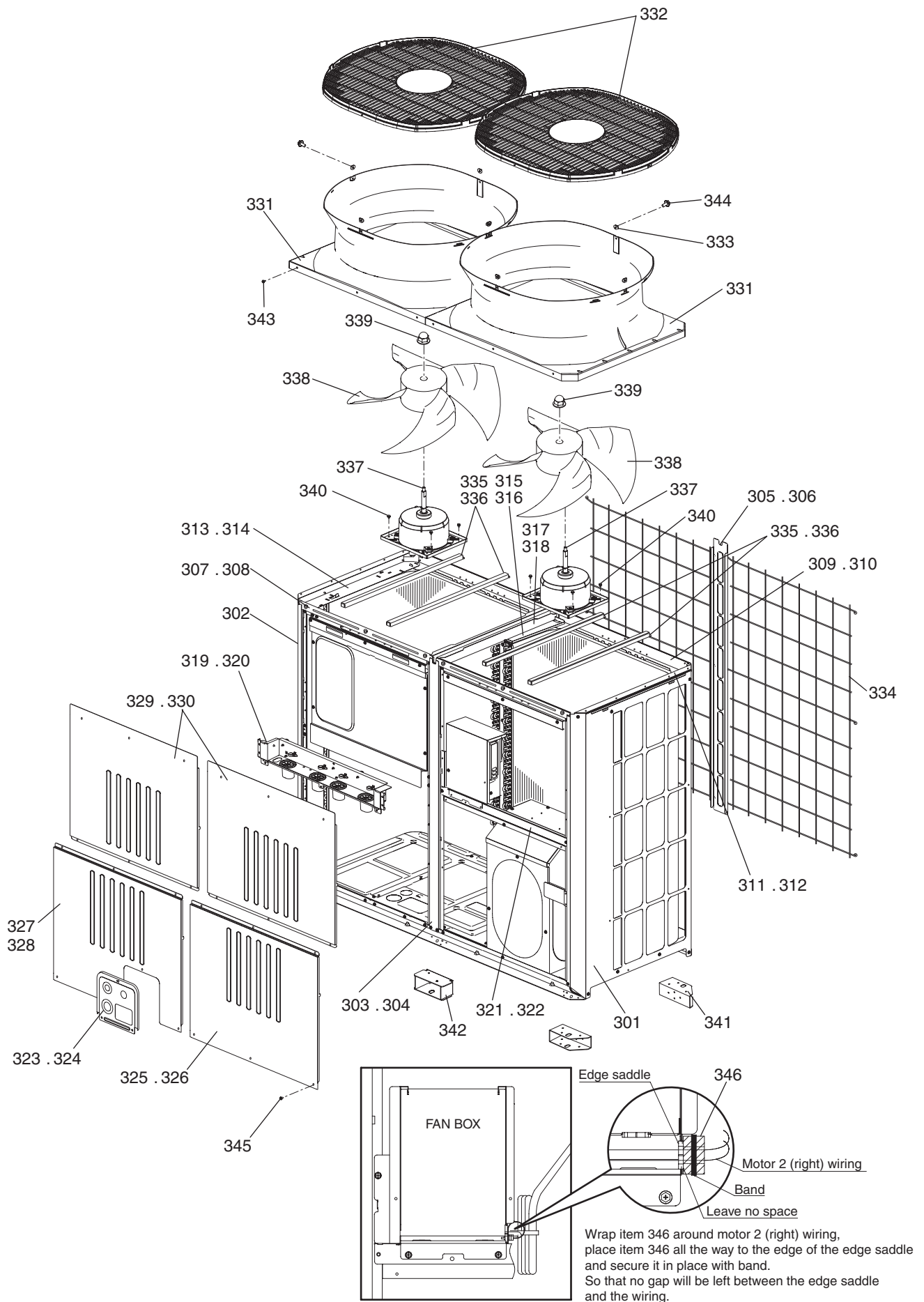

No.	Part No.	G : RoHS Apply Only W : RoHS Apply by Running Change		Spec.	PUHY-P450YKB-A1.TH	PUHY-P450YKB-A1.TH-BS	PUHY-P500YKB-A1.TH	PUHY-P500YKB-A1.TH-BS	Dwg. No.	Notes for the models	Revision info.	
		Part Name										
301	E17 A59 085	G		Panel R	1	1	1	1	KJ00C589G05			
302	E17 A59 086	G		Panel L	1	1	1	1	KJ00C588G05			
303	E17 988 812	G		Pillar assy MF	1		1		KJ00C629G01			
304	E17 995 812	G		Pillar assy MF			1	1	KJ00C629G02			
305	E17 988 814	G		Pillar MB	1		1		KJ00C627G01			
306	E17 995 814	G		Pillar MB			1	1	KJ00C627G02			
307	E17 988 256	G		Frame assy F	1		1		KJ00C476G01			
308	E17 995 256	G		Frame assy F			1	1	KJ00C613G01			
309	E17 A64 255	G		Frame assy B	1		1		KJ00C610G03			
310	E17 A71 255	G		Frame assy B			1	1	KJ00C610G04			
311	E17 A59 254	G		Frame assy LR	1		1		KJ00L905G01			
312	E17 A66 254	G		Frame assy LR			1	1	KJ00L905G02			
313	E17 A59 253	G		Frame assy L	1		1		KJ00L906G01			
314	E17 A66 253	G		Frame assy L			1	1	KJ00L906G02			
315	E17 988 810	G		Plate Hex assy	1		1		KJ00C753G01			
316	E17 995 810	G		Plate Hex assy			1	1	KJ00C753G02			
317	E17 988 259	G		Frame MT	1		1		KJ00C763G01			
318	E17 995 259	G		Frame MT			1	1	KJ00C763G02			
319	E17 A64 257	G		Frame assy M	1		1		KJ00C636G05			
320	E17 A71 257	G		Frame assy M			1	1	KJ00C636G06			
321	E17 988 260	G		Frame MR	1		1		KJ02C482G01			
322	E17 995 260	G		Frame MR			1	1	KJ00C677G01			
323	E17 630 910	G		Pipe cover	1		1		KB00P794G01			
324	E17 631 910	G		Pipe cover			1	1	KB00P794G02			
325	E17 988 232	G		Panel FBR	1		1		KJ00C669G03			
326	E17 995 232	G		Panel FBR			1	1	KJ00C669G04			
327	E17 999 232	G		Panel FBL	1		1		KJ00C668G03			
328	E17 A04 232	G		Panel FBL			1	1	KJ00C668G04			
329	E17 981 232	G		Panel FU	2		2		KJ00C664G03			
330	E17 989 232	G		Panel FU			2	2	KJ00C664G04			
331	E17 988 509	G		Bell mouth	2	2	2	2	KB25A621G01			
332	E17 981 521	G		Fan guard	2	2	2	2	KB25A623G03			
333	E17 981 810	G		Plate fanguard	8	8	8	8	KD02K443G01			
334	E17 988 523	G		Fin guard B (XL)	2	2	2	2	KB07N808G01			
335	E17 981 290	G		Fan stand	4		4		KD02K465G01			
336	E17 989 290	G		Fan stand			4	4	KD00K588G01			
337	E17 B87 301	G		Outdoor fan motor	2	2	2	2	KJ61T431H01	In-house produced motor	Chg.	
338	E17 622 501	G		Propeller fan	2	2	2	2	KB25A284H02			
339	E17 622 508	G		Cap nut	M12	2	2	2	2	KB12S220H02		
340	E17 622 250	G		Screw upset	M6x10	10	10	10	10	KB12S261H01	8PCS/UNIT	
341	KD00M720G03	G		Attachment leg		4	4	4	4	KD00M720G03		
342	KD00P364G02	G		Attachment leg		2	2	2	2	KD00P364G02		
343	E17 633 250	G		Screw	M5x12	20	20	20	20	KB12S217H01	26PCS/UNIT	
344	E17 983 250	G		Screw	M5x16	10	10	10	10	KB12S217H02	8PCS/UNIT	
345	E17 623 250	G		Screw	M5x10 KNURLED	20	20	20	20	KB12S216H01	168PCS/UNIT	





PUHY-P200,P250YKB-A1.TH  
 PUHY-P200,P250YKB-A1.TH-BS

FUNCTIONAL PARTS (1)

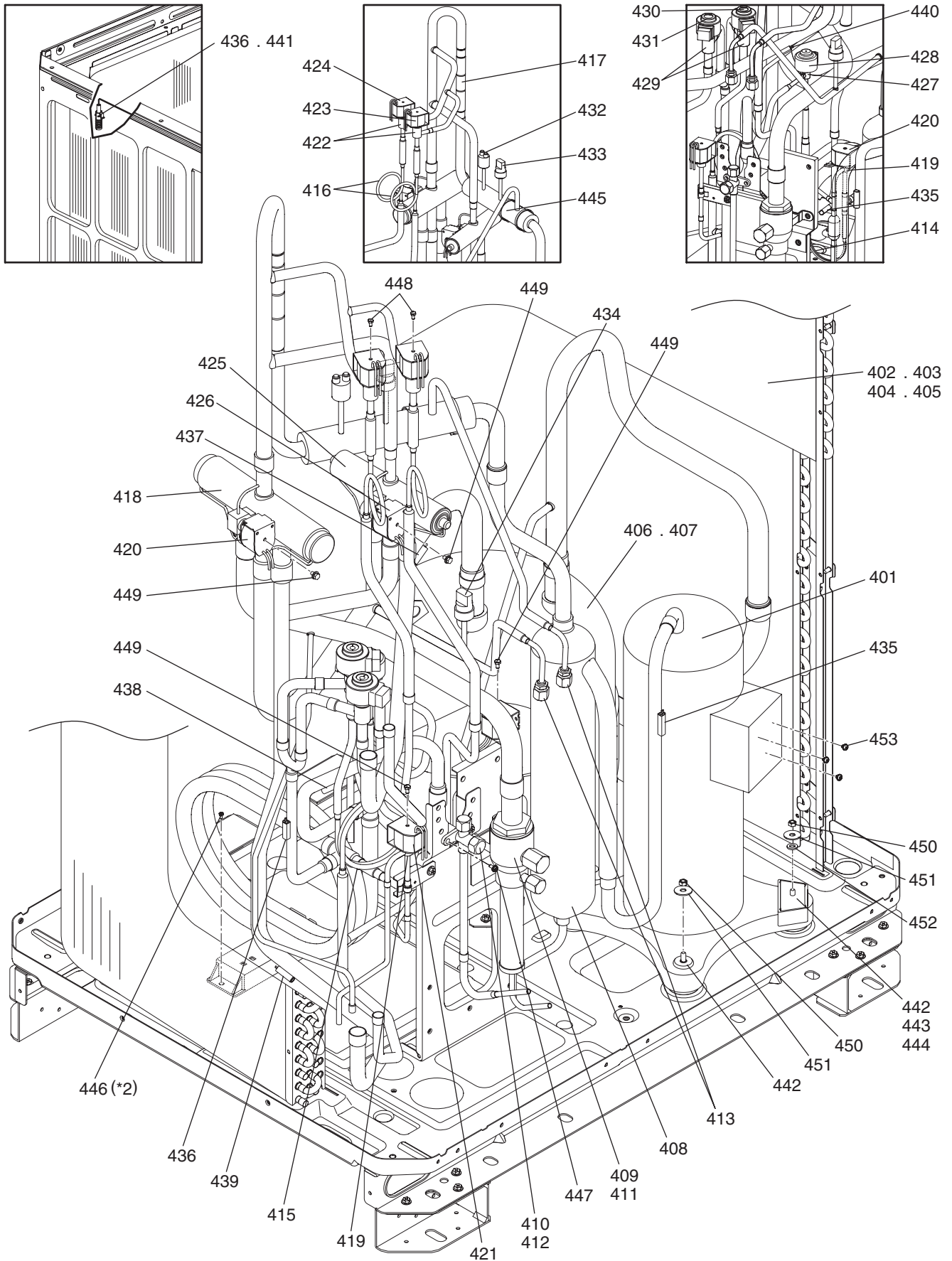

\*2 PUHY-P200YKB-A1.TH(-BS) ... 111 PCS/UNIT  
 PUHY-P250YKB-A1.TH(-BS) ... 112 PCS/UNIT

No.	Part No.	G : RoHS Apply Only W : RoHS Apply by Running Change		Spec.	PUHY-P200YKB-A1.TH	PUHY-P200YKB-A1.TH-BS	PUHY-P250YKB-A1.TH	PUHY-P250YKB-A1.TH-BS	Dwg. No.	Notes for the models	Revision info.
		Part Name									
401	E17 981 900	G	Compressor	ENB62FB-YE	1	1	1	1	KEP10132B04		
402	E17 A59 630	G	Outdoor heat exchanger	2L	1				KJ01G667G01		
403	E17 A66 630	G	Outdoor heat exchanger	2L BS		1			KJ01G667G02		
404	E17 A60 630	G	Outdoor heat exchanger	2.5L			1		KJ01G668G01		
405	E17 A67 630	G	Outdoor heat exchanger	2.5L BS				1	KJ01G668G02		
406	E17 622 932	G	Accumulator		1		1		KB54N072G02		
407	E17 623 932	G	Accumulator	BS		1		1	KD54C893H01		
408	E17 983 299	G	Oil separator		1	1	1	1	KJ00C301G03		
409	E17 627 661	G	Ball valve	SBV-JA10YGME-3	1	1	1	1	KR50C207H01	<BV1>	
410	E17 981 662	G	Valve	FSV-JA3GME-11	1	1	1	1	KR50C261H01	<BV2>	
411	E17 624 933	G	Strainer	25.4D	1	1	1	1	KD53C139G01	<ST1>	
412	E17 622 933	G	Strainer	19.05D	1	1	1	1	KB53S159G01	<ST2>	
413	E17 622 643	G	Check joint	R410A	2	2	2	2	KR50C244H01	<CJ1,CJ2>	
414	E17 622 936	G	Capillary tube		1	1	1	1	KB49S267G01	<CP1>	
415	E17 A59 936	G	Capillary tube		1	1	1	1	KD49M566G04	<CP3>	
416	E17 A60 936	G	Capillary tube		2	2	2	2	KD49S460G01	<CP4,CP5>	
417	E17 981 642	G	Check valve	YAV-P11Y5HMD-1	1	1	1	1	KR50D129H01	<CV1>	
418	E17 B35 961	G	Four way valve	STF-H07	1	1	1	1	KR50C304H01	<21S4a>	
419	E17 981 492	G	Solenoid valve	FD2A77	2	2	2	2	KR50D126H01	<SV1a,SV9>	
420	E17 B35 490	G	Solenoid valve coil		1	1	1	1	KJ00G674G03	<21S4a,SV1a>	
421	E17 A60 490	G	Solenoid valve coil		1	1	1	1	KD00M603G01	<SV9>	
422	E17 A59 492	G	Solenoid valve	VPV-603DQ3	2	2	2	2	KR50C273H01	<SV10,SV11>	
423	E17 A66 490	G	Solenoid valve coil		1	1	1	1	KD00M609G03	<SV10>	
424	E17 A67 490	G	Solenoid valve coil		1	1	1	1	KD00M610G04	<SV11>	
425	E17 B36 961	G	Four way valve	STF-H04	1	1	1	1	KR50C305H01	<21S4b>	
426	E17 B36 490	G	Solenoid valve coil		1	1	1	1	KD00M602G03	<21S4b>	
427	E17 A59 640	G	Linear expansion valve	CAM-B35YGMD-2	1	1	1	1	KR50C271H01	<LEV1>	
428	E17 622 493	G	Solenoid valve coil	CAM-MD12MD-123	1	1	1	1	KR50C238H01	<LEV1>	
429	E17 624 640	G	Linear expansion valve	PAM-BBOYGMD-1	2	2	2	2	KR50C215H01	<LEV2a,LEV2b>	
430	E17 623 493	G	Solenoid valve coil	PAM-MD12MD-3	1	1	1	1	KR50C212H02	<LEV2a>	
431	E17 A59 493	G	Solenoid valve coil	PAM-MD12MD-9	1	1	1	1	KR50C287H01	<LEV2b>	
432	E17 988 646	G	Pressure switch	ACB-1UB28W	1	1	1	1	KD00K089G01	<63H1>	
433	E17 982 646	G	Pressure sensor	NSK-BD042D-272	1	1	1	1	KB00H904G20	<63HS1>	
434	E17 981 647	G	Pressure sensor	NSK-BD017D-272	1	1	1	1	KB00H904G21	<63LS1>	
435	E17 A59 307	G	Thermistor	150-522-96001,158-204-97484	1	1	1	1	KJ00G686G02	<TH2,TH4>	
436	E17 A60 307	G	Thermistor	150-522-96001	1	1	1	1	KJ00G687G03	<TH3,TH7>	
437	E17 A66 307	G	Thermistor	150-522-96001	1	1	1	1	KD00M611G02	<TH5>	
438	E17 A67 307	G	Thermistor	150-522-96001	1	1	1	1	KD00M612G03	<TH6>	
439	E17 A73 307	G	Thermistor	158-532-97017	1	1	1	1	KD00M613G03	<TH9>	
440	E17 A74 307	G	Thermistor	158-532-97056	1	1	1	1	KD00M614G03	<TH11>	
441	E17 622 241	G	Sensor holder		1	1	1	1	KB25J374G01	<TH7>	
442	E17 622 506	G	Comp.rubber mount set	4 Rubbers/SET	4	4	4	4	KB31S115H01		
443	KD00K624G01	G	Attachment (HH)		1		1		KD00K624G01		
444	KD00K624G02	G	Attachment (HH)	BS		1		1	KD00K624G02		
445	E17 A59 910	G	Pipe cover		1	1	1	1	KD01M601G01		

No.	Part No.	G : RoHS Apply Only W : RoHS Apply by Running Change		Spec.	PUHY-P200YKB-A1.TH 20	PUHY-P200YKB-A1.TH-BS 20	PUHY-P250YKB-A1.TH 20	PUHY-P250YKB-A1.TH-BS 20	Dwg. No.	Notes for the models	Revision info.
			Part Name								
446	E17 623 250	G	Screw	M5x10 KNURLED	20	20	20	20	KB12S216H01	*2	
447	E17 630 250	G	Screw	M5x14 KNURLED	10	10	10	10	KB12S216H02	4PCS/UNIT	
448	E17 631 250	G	Screw	M4x8 SEMS	10	10	10	10	KB12U718H01	4PCS/UNIT	
449	E17 984 250	G	Screw upset	M5x9	10	10	10	10	KD12D936H02	2PCS/UNIT	
450	E17 623 508	G	Nut	M6 NUT	10	10	10	10	VU12D248H01	3PCS/UNIT	
451	E17 622 097	G	Washer		10	10	10	10	VU55D247H02	3PCS/UNIT	
452	E17 981 098	G	Spring washer	8	10	10	10	10	KD04K591H01	1PCS/UNIT	
453	E17 632 250	G	Screw PMP BS	M5x10 BRASS	10	10	10	10	KB12S219H01	3PCS/UNIT	

PUHY-P300,P350,P400YKB-A1.TH  
 PUHY-P300,P350,P400YKB-A1.TH-BS

FUNCTIONAL PARTS (2)

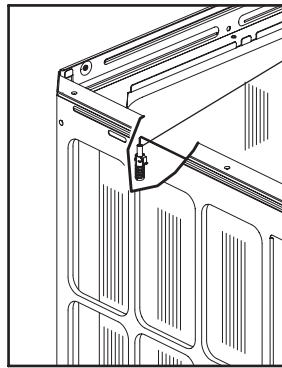

536 .541

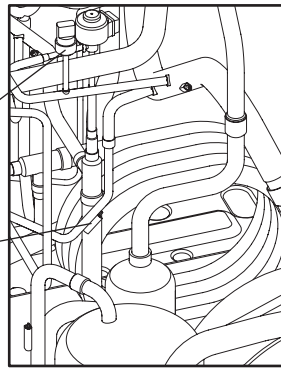

534

535

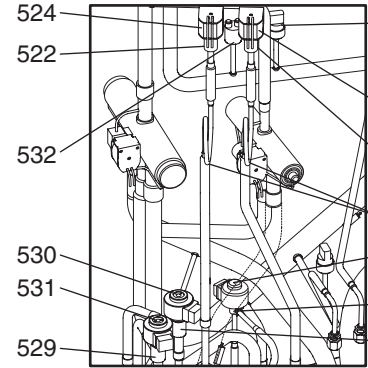

524

522

532

530

531

529

533

523

522

516

528

527

529

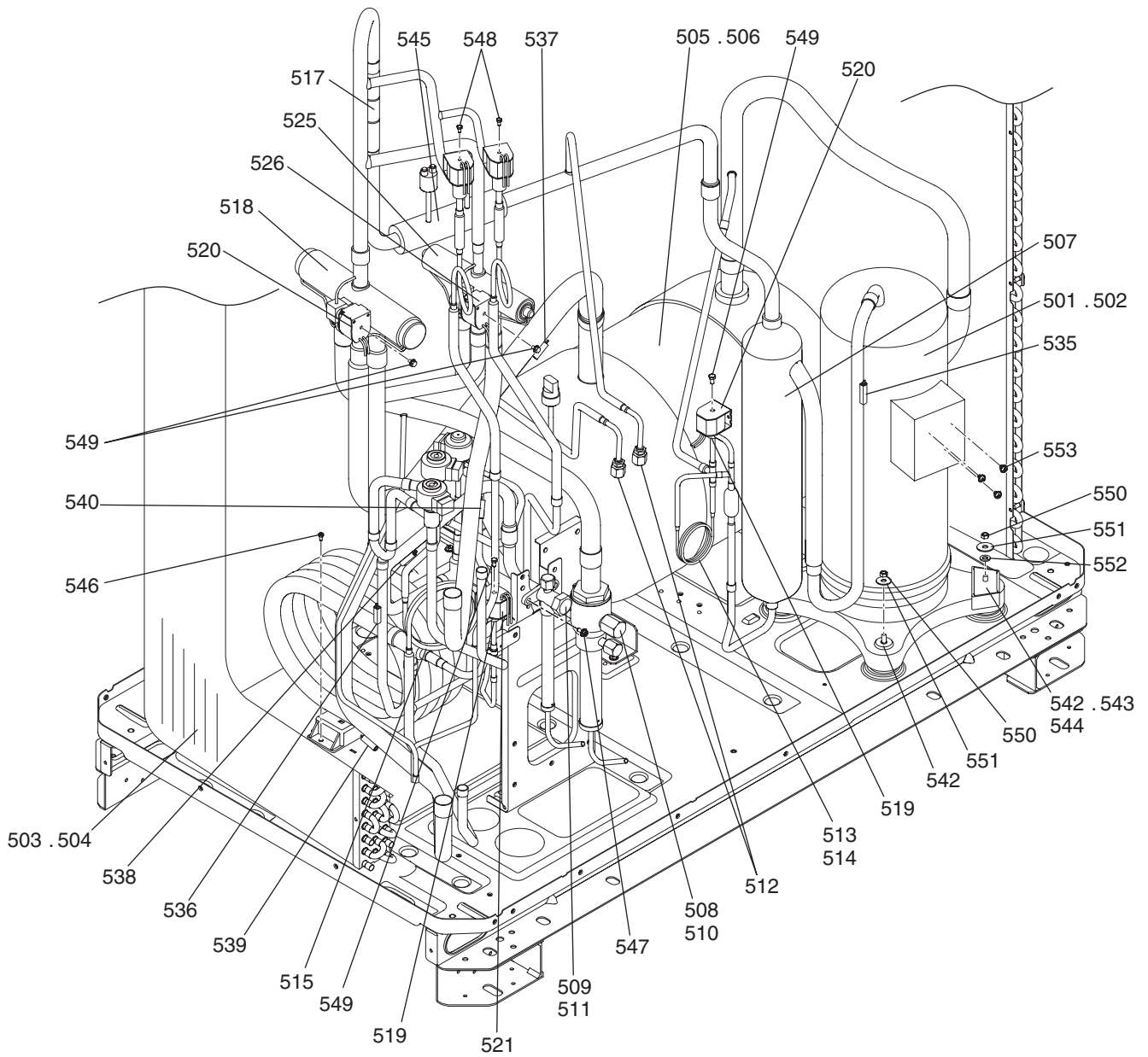

545

548

537

505 .506

549

520

517

525

526

518

520

549

540

546

503 .504

538

536

539

515

549

519

521

509

511

547

508

510

512

513

514

519

542

551

542 .543

544

550

551

552

507

501 .502

535

553

No.	Part No.	G : RoHS Apply Only W : RoHS Apply by Running Change		Spec.	PUHY-P300YKB-A1.TH	PUHY-P300YKB-A1.TH-BS	PUHY-P350YKB-A1.TH	PUHY-P350YKB-A1.TH-BS	PUHY-P400YKB-A1.TH	PUHY-P400YKB-A1.TH-BS	Dwg. No.	Notes for the models	Revision info.
			Part Name										
501	E17 983 900	G	Compressor	HNB83FB-YE	1	1	1	1			KEP10136B03		
502	E17 985 900	G	Compressor	HNB84FC1-Y					1	1	KEP10126B02		
503	E17 A61 630	G	Outdoor heat exchanger	3L	1		1		1		KJ01G669G01		
504	E17 A68 630	G	Outdoor heat exchanger	3L BS		1		1		1	KJ01G669G02		
505	E17 988 932	G	Accumulator		1		1		1		KB54N780G01		
506	E17 995 932	G	Accumulator	BS		1		1		1	KD54C892H02		
507	E17 983 299	G	Oil separator		1	1	1	1	1	1	KJ00C301G03		
508	E17 627 661	G	Ball valve	SBV-JA10YGME-3	1	1	1	1	1	1	KR50C207H01	<BV1>	
509	E17 984 662	G	Valve	FSV-JA5GME-19	1	1	1	1	1	1	KR50C259H01	<BV2>	
510	E17 624 933	G	Strainer	25.4D	1	1	1	1	1	1	KD53C139G01	<ST1>	
511	E17 622 933	G	Strainer	19.05D	1	1	1	1	1	1	KB53S159G01	<ST2>	
512	E17 622 643	G	Check joint	R410A	2	2	2	2	2	2	KR50C244H01	<CJ1,CJ2>	
513	E17 A61 936	G	Capillary tube		1	1	1	1			KD49M523G01	<CP1>	
514	E17 A63 936	G	Capillary tube						1	1	KD49M579G01	<CP1>	
515	E17 A59 936	G	Capillary tube		1	1	1	1	1	1	KD49M566G04	<CP3>	
516	E17 A62 936	G	Capillary tube		2	2	2	2	2	2	KD49S461G01	<CP4,CP5>	
517	E17 981 642	G	Check valve	YAV-P11Y5HMD-1	1	1	1	1	1	1	KR50D129H01	<CV1>	
518	E17 B35 961	G	Four way valve	STF-H07	1	1	1	1	1	1	KR50C304H01	<21S4a>	
519	E17 981 492	G	Solenoid valve	FD2A77	2	2	2	2	2	2	KR50D126H01	<SV1a,SV9>	
520	E17 B78 490	G	Solenoid valve coil		1	1	1	1	1	1	KJ00G779G03	<21S4a,SV1a>	
521	E17 A62 490	G	Solenoid valve coil		1	1	1	1	1	1	KD00M724G02	<SV9>	
522	E17 A59 492	G	Solenoid valve	VPV-603DQ3	2	2	2	2	2	2	KR50C273H01	<SV10,SV11>	
523	E17 A63 490	G	Solenoid valve coil		1	1	1	1	1	1	KD00M725G04	<SV10>	
524	E17 A69 490	G	Solenoid valve coil		1	1	1	1	1	1	KD00M726G04	<SV11>	
525	E17 B36 961	G	Four way valve	STF-H04	1	1	1	1	1	1	KR50C305H01	<21S4b>	
526	E17 B80 490	G	Solenoid valve coil		1	1	1	1	1	1	KD00M723G04	<21S4b>	
527	E17 A59 640	G	Linear expansion valve	CAM-B35YGMD-2	1	1	1	1	1	1	KR50C271H01	<LEV1>	
528	E17 622 493	G	Solenoid valve coil	CAM-MD12MD-123	1	1	1	1	1	1	KR50C238H01	<LEV1>	
529	E17 624 640	G	Linear expansion valve	PAM-BBOYGMD-1	2	2	2	2	2	2	KR50C215H01	<LEV2a,LEV2b>	
530	E17 623 493	G	Solenoid valve coil	PAM-MD12MD-3	1	1	1	1	1	1	KR50C212H02	<LEV2a>	
531	E17 A59 493	G	Solenoid valve coil	PAM-MD12MD-9	1	1	1	1	1	1	KR50C287H01	<LEV2b>	
532	E17 988 646	G	Pressure switch	ACB-1UB28W	1	1	1	1	1	1	KD00K089G01	<63H1>	
533	E17 982 646	G	Pressure sensor	NSK-BD042D-272	1	1	1	1	1	1	KB00H904G20	<63HS1>	
534	E17 981 647	G	Pressure sensor	NSK-BD017D-272	1	1	1	1	1	1	KB00H904G21	<63LS1>	
535	E17 A61 307	G	Thermistor	150-522-96001,158-204-97484	1	1	1	1	1	1	KJ00G781G02	<TH2,TH4>	
536	E17 A62 307	G	Thermistor	150-522-96001	1	1	1	1	1	1	KJ00G782G02	<TH3,TH7>	
537	E17 A63 307	G	Thermistor	150-522-96001	1	1	1	1	1	1	KD00M727G02	<TH5>	
538	E17 A68 307	G	Thermistor	150-522-96001	1	1	1	1	1	1	KD00M728G02	<TH6>	
539	E17 A69 307	G	Thermistor	158-532-97017	1	1	1	1	1	1	KD00M729G03	<TH9>	
540	E17 A70 307	G	Thermistor	158-532-97056	1	1	1	1	1	1	KD00M730G03	<TH11>	
541	E17 622 241	G	Sensor holder		1	1	1	1	1	1	KB25J374G01	<TH7>	
542	E17 622 506	G	Comp.rubber mount set	4 Rubbers/SET	4	4	4	4	4	4	KB31S115H01		
543	KD00K624G01	G	Attachment (HH)		1		1		1		KD00K624G01		
544	KD00K624G02	G	Attachment (HH)	BS		1		1		1	KD00K624G02		
545	E17 A61 910	G	Pipe cover		1	1	1	1	1	1	KD01M722G01		



PUHY-P450,P500YKB-A1.TH  
 PUHY-P450,P500YKB-A1.TH-BS

FUNCTIONAL PARTS (3)

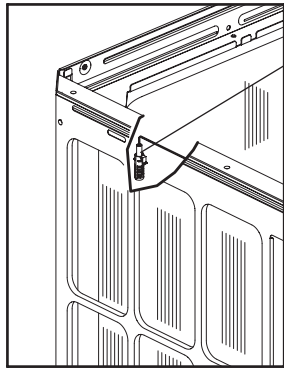

637 . 642

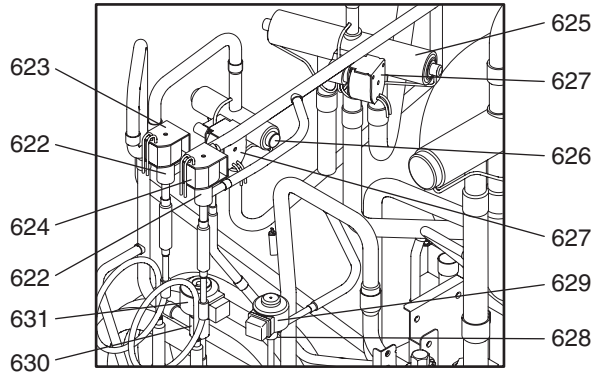

623 625  
 622 627  
 624 626  
 622 627  
 631 629  
 630 628

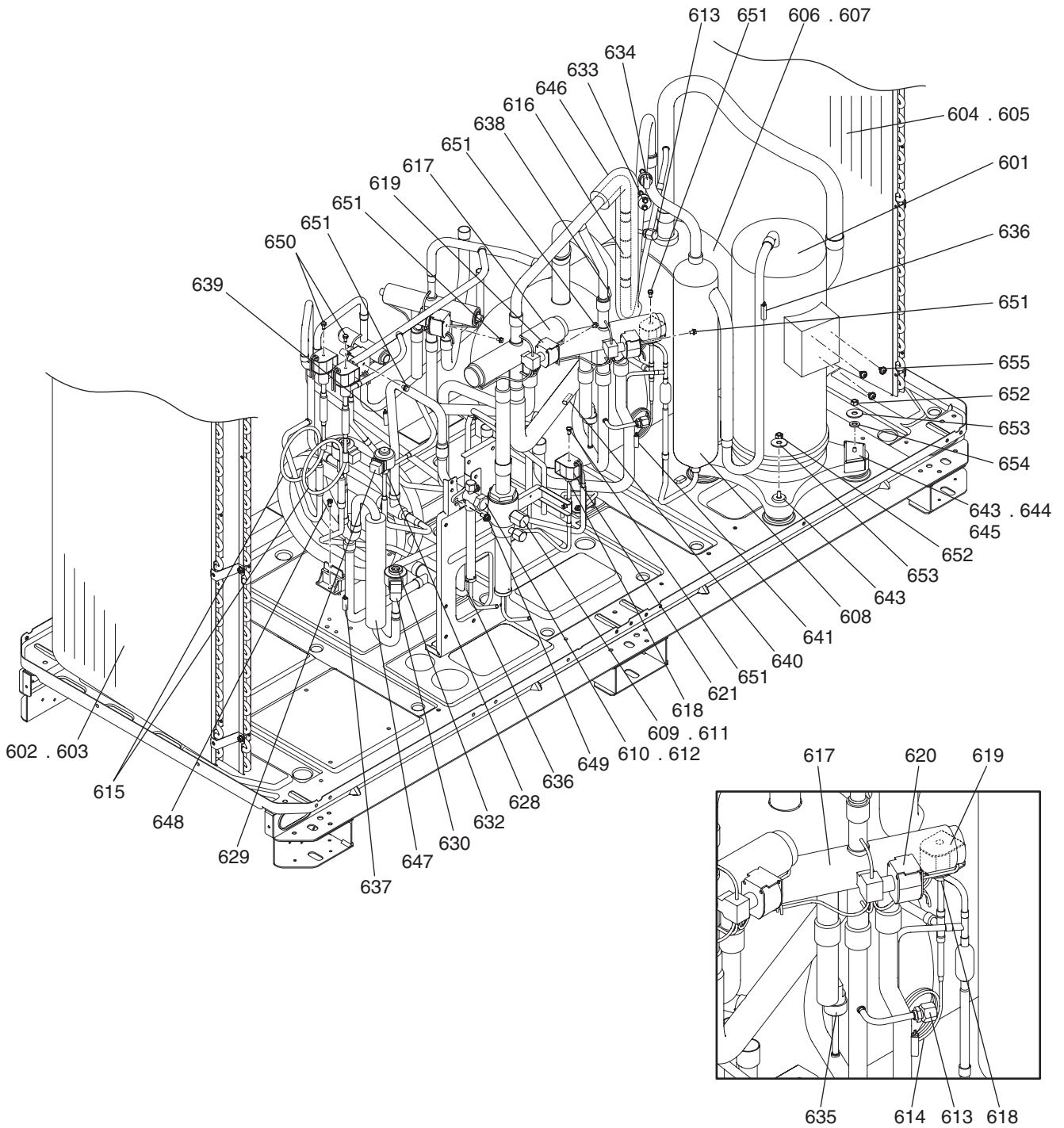

613 651 606 . 607  
 634  
 646  
 616  
 638  
 651  
 617  
 619  
 650  
 651  
 639  
 604 . 605  
 601  
 636  
 651  
 655  
 652  
 653  
 654  
 643 . 644  
 645  
 652  
 643  
 608  
 641  
 640  
 651  
 621  
 618  
 609 . 611  
 610 . 612  
 649  
 636  
 628  
 632  
 636  
 629  
 648  
 615  
 602 . 603  
 648  
 629  
 647  
 630  
 637

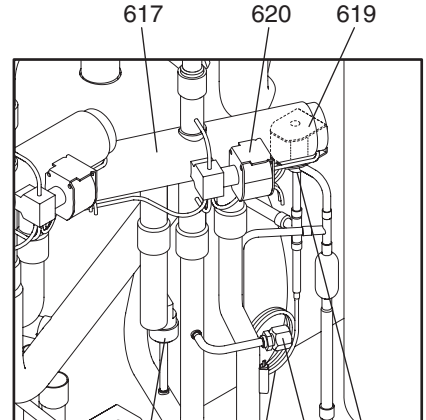

617 620 619  
 635 614 613 618



No.	Part No.	G : RoHS Apply Only W : RoHS Apply by Running Change		Spec.	PUHY-P450YKB-A1.TH	PUHY-P450YKB-A1.TH-BS	PUHY-P500YKB-A1.TH	PUHY-P500YKB-A1.TH-BS	Dwg. No.	Notes for the models	Revision info.
			Part Name								
601	E17 A64 900	G	Compressor	HNB84FD-YE	1	1	1	1	KEP10126B05		
602	E17 A64 630	G	Outdoor heat exchanger	3L L	1		1		KJ01L346G01		
603	E17 A71 630	G	Outdoor heat exchanger	3L L BS		1	1		KJ01L346G02		
604	E17 A65 630	G	Outdoor heat exchanger	3L R	1		1		KJ01L347G01		
605	E17 A72 630	G	Outdoor heat exchanger	3L R BS		1	1		KJ01L347G02		
606	E17 988 932	G	Accumulator		1		1		KB54N780G01		
607	E17 995 932	G	Accumulator	BS		1	1		KD54C892H02		
608	E17 983 299	G	Oil separator		1	1	1	1	KJ00C301G03		
609	E17 627 661	G	Ball valve	SBV-JA10YGME-3	1	1	1	1	KR50C207H01	<BV1>	
610	E17 984 662	G	Valve	FSV-JA5GME-19	1	1	1	1	KR50C259H01	<BV2>	
611	E17 624 933	G	Strainer	25.4D	1	1	1	1	KD53C139G01	<ST1>	
612	E17 622 933	G	Strainer	19.05D	1	1	1	1	KB53S159G01	<ST2>	
613	E17 622 643	G	Check joint	R410A	2	2	2	2	KR50C244H01	<CJ1,CJ2>	
614	E17 A63 936	G	Capillary tube		1	1	1	1	KD49M579G01	<CP1>	
615	E17 A64 936	G	Capillary tube		2	2	2	2	KD49S462G01	<CP4,CP5>	
616	E17 981 642	G	Check valve	YAV-P11Y5HMD-1	1	1	1	1	KR50D129H01	<CV1>	
617	E17 B35 961	G	Four way valve	STF-H07	2	2	2	2	KR50C304H01	<21S4a,21S4c>	
618	E17 981 492	G	Solenoid valve	FD2A77	2	2	2	2	KR50D126H01	<SV1a,SV9>	
619	E17 B81 490	G	Solenoid valve coil		1	1	1	1	KJ00L386G03	<21S4a,SV1a>	
620	E17 B86 490	G	Solenoid valve coil		1	1	1	1	KD00P229G03	<21S4c>	
621	E17 A71 490	G	Solenoid valve coil		1	1	1	1	KD00P230G02	<SV9>	
622	E17 A59 492	G	Solenoid valve	VPV-603DQ3	2	2	2	2	KR50C273H01	<SV10,SV11>	
623	E17 A72 490	G	Solenoid valve coil		1	1	1	1	KD00P231G02	<SV10>	
624	E17 A75 490	G	Solenoid valve coil		1	1	1	1	KD00P232G02	<SV11>	
625	E17 B36 961	G	Four way valve	STF-H04	1	1	1	1	KR50C305H01	<21S4b>	
626	E17 988 961	G	Two way valve	VR43202	1	1	1	1	KR50C250H01	<SV5b>	
627	E17 B87 490	G	Solenoid valve coil		1	1	1	1	KJ00L464G03	<21S4b,SV5b>	
628	E17 A59 640	G	Linear expansion valve	CAM-B35YGMD-2	1	1	1	1	KR50C271H01	<LEV1>	
629	E17 622 493	G	Solenoid valve coil	CAM-MD12MD-123	1	1	1	1	KR50C238H01	<LEV1>	
630	E17 624 640	G	Linear expansion valve	PAM-BBOYGMD-1	2	2	2	2	KR50C215H01	<LEV2a,LEV2b>	
631	E17 623 493	G	Solenoid valve coil	PAM-MD12MD-3	1	1	1	1	KR50C212H02	<LEV2a>	
632	E17 A59 493	G	Solenoid valve coil	PAM-MD12MD-9	1	1	1	1	KR50C287H01	<LEV2b>	
633	E17 988 646	G	Pressure switch	ACB-1UB28W	1	1	1	1	KD00K089G01	<63H1>	
634	E17 984 646	G	Pressure sensor	NSK-BD042D-272	1	1	1	1	KB00F889G33	<63HS1>	
635	E17 988 647	G	Pressure sensor	NSK-BD017D-183	1	1	1	1	KB00F889G13	<63LS>	
636	E17 A64 307	G	Thermistor	150-522-96001,158-204-97484	1	1	1	1	KJ00L384G02	<TH2,TH4>	
637	E17 A65 307	G	Thermistor	150-522-96001	1	1	1	1	KJ00L385G03	<TH3,TH7>	
638	E17 A71 307	G	Thermistor	150-522-96001	1	1	1	1	KD00P224G02	<TH5>	
639	E17 A72 307	G	Thermistor	150-522-96001	1	1	1	1	KD00P225G02	<TH6>	
640	E17 A75 307	G	Thermistor	158-532-97056	1	1	1	1	KD00P226G02	<TH9>	
641	E17 A76 307	G	Thermistor	158-532-97056	1	1	1	1	KD00P227G02	<TH11>	
642	E17 622 241	G	Sensor holder		1	1	1	1	KB25J374G01	<TH7>	
643	E17 622 506	G	Comp.rubber mount set	4 Rubbers/SET	4	4	4	4	KB31S115H01		
644	KD00K624G01	G	Attachment (HH)		1		1		KD00K624G01		
645	KD00K624G02	G	Attachment (HH)	BS		1		1	KD00K624G02		



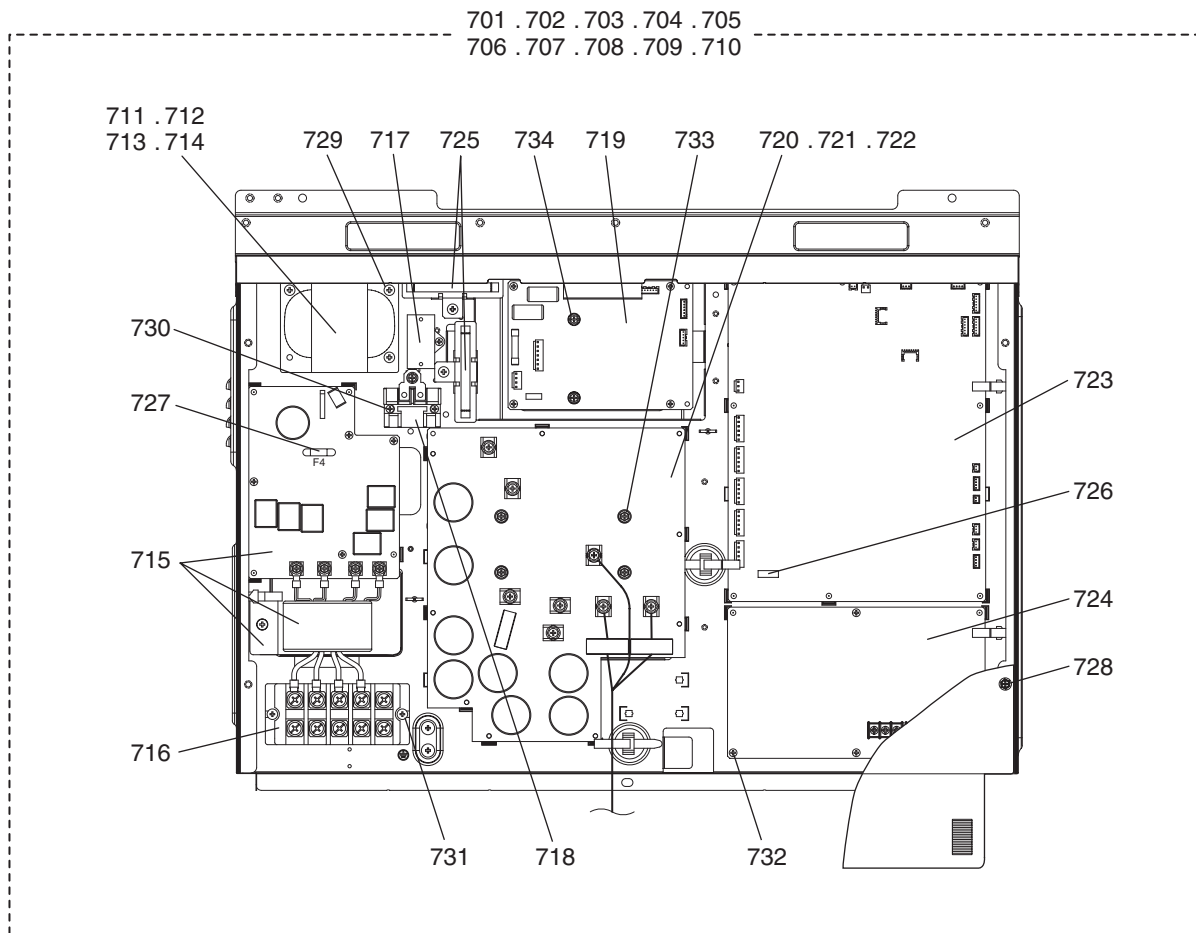





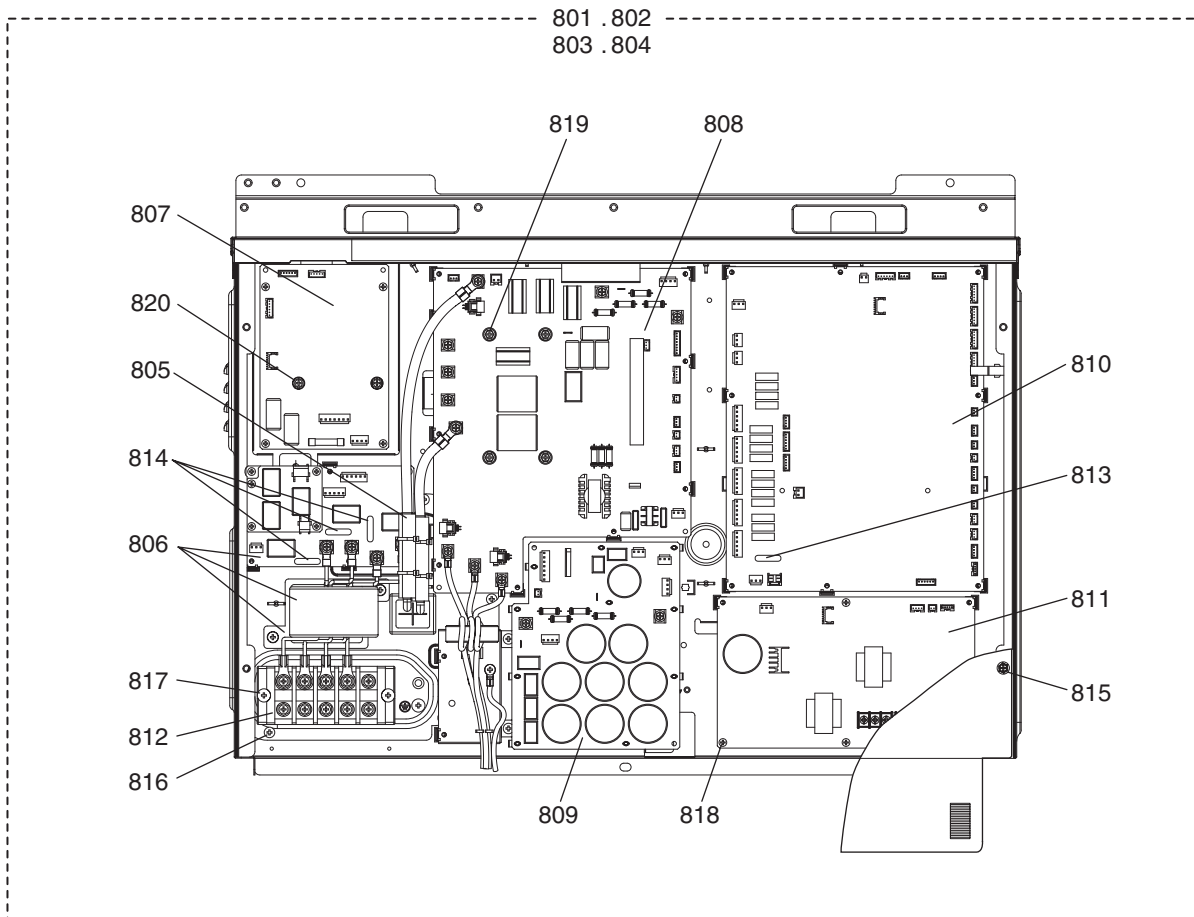



PUHY-P450,P500YKB-A1.TH  
PUHY-P450,P500YKB-A1.TH-BS

FAN BOX PARTS

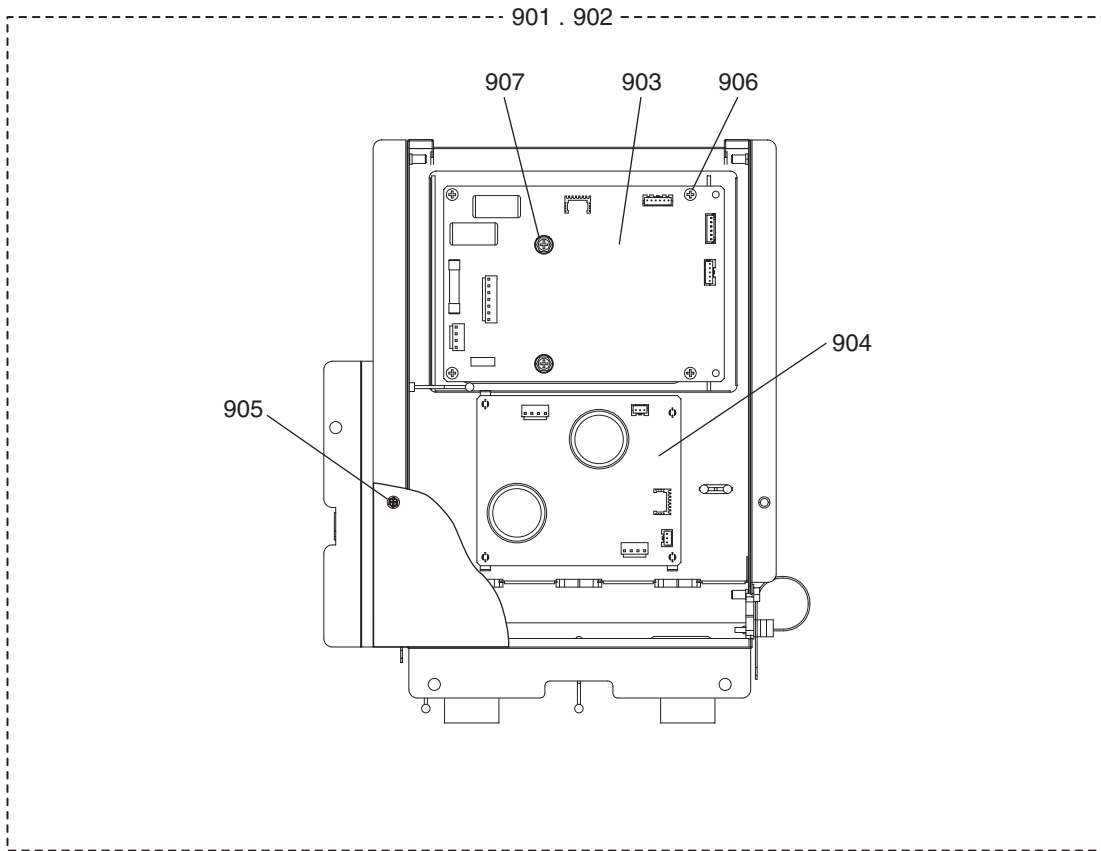





**MITSUBISHI ELECTRIC CORPORATION**

---

BWE01430B (20150930)