

SERVICE PARTS LIST FOR MITSUBISHI ELECTRIC PACKAGED AIR-CONDITIONERS

Series : PURY-P·Y(S)LM-A1(-BS)

For use with the R410A

Feb. 2015
BWE015010

INDEX
PURY-P200YLM-A1
PURY-P200YLM-A1-BS
PURY-P250YLM-A1
PURY-P250YLM-A1-BS
PURY-P300YLM-A1
PURY-P300YLM-A1-BS
PURY-P350YLM-A1
PURY-P350YLM-A1-BS
PURY-P400YLM-A1
PURY-P400YLM-A1-BS
PURY-P450YLM-A1
PURY-P450YLM-A1-BS
PURY-P500YLM-A1
PURY-P500YLM-A1-BS

Refer to the next page for the package names.

The Package name list

PURY-P400YSLM-A1(-BS)	[PURY-P200YLM-A1(-BS)+PURY-P200YLM-A1(-BS)]
PURY-P450YSLM-A1(-BS)	[PURY-P200YLM-A1(-BS)+PURY-P250YLM-A1(-BS)]
PURY-P500YSLM-A1(-BS)	[PURY-P250YLM-A1(-BS)+PURY-P250YLM-A1(-BS)]
PURY-P550YSLM-A1(-BS)	[PURY-P250YLM-A1(-BS)+PURY-P300YLM-A1(-BS)]
PURY-P600YSLM-A1(-BS)	[PURY-P300YLM-A1(-BS)+PURY-P300YLM-A1(-BS)]
PURY-P650YSLM-A1(-BS)	[PURY-P300YLM-A1(-BS)+PURY-P350YLM-A1(-BS)]
PURY-P700YSLM-A1(-BS)	[PURY-P350YLM-A1(-BS)+PURY-P350YLM-A1(-BS)]
PURY-P750YSLM-A1(-BS)	[PURY-P350YLM-A1(-BS)+PURY-P400YLM-A1(-BS)]
PURY-P800YSLM-A1(-BS)	[PURY-P400YLM-A1(-BS)+PURY-P400YLM-A1(-BS)]
PURY-P850YSLM-A1(-BS)	[PURY-P400YLM-A1(-BS)+PURY-P450YLM-A1(-BS)]
PURY-P900YSLM-A1(-BS)	[PURY-P450YLM-A1(-BS)+PURY-P450YLM-A1(-BS)]

PURY-P200YLM-A1(-BS)
PURY-P250YLM-A1(-BS)

EXTERNAL PARTS & BLOWER PARTS (1)

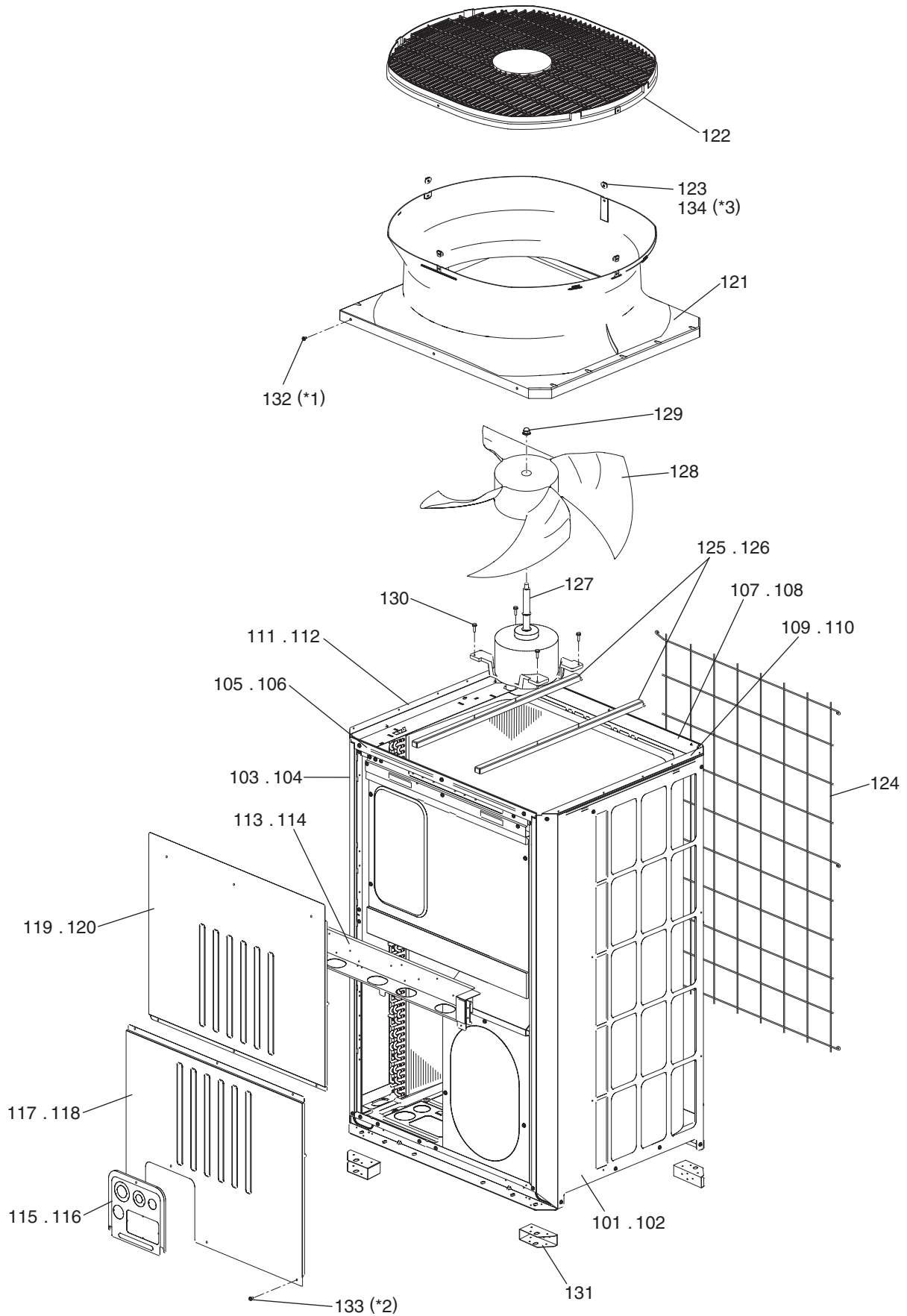

- *1 30 WFT Screws (part No.132)
- *2 91 H Screws (part No.133)
- *3 4 WFT Screws (part No.134)

PURY-P300YLM-A1(-BS)
 PURY-P350YLM-A1(-BS)
 PURY-P400YLM-A1(-BS)

EXTERNAL PARTS & BLOWER PARTS (2)

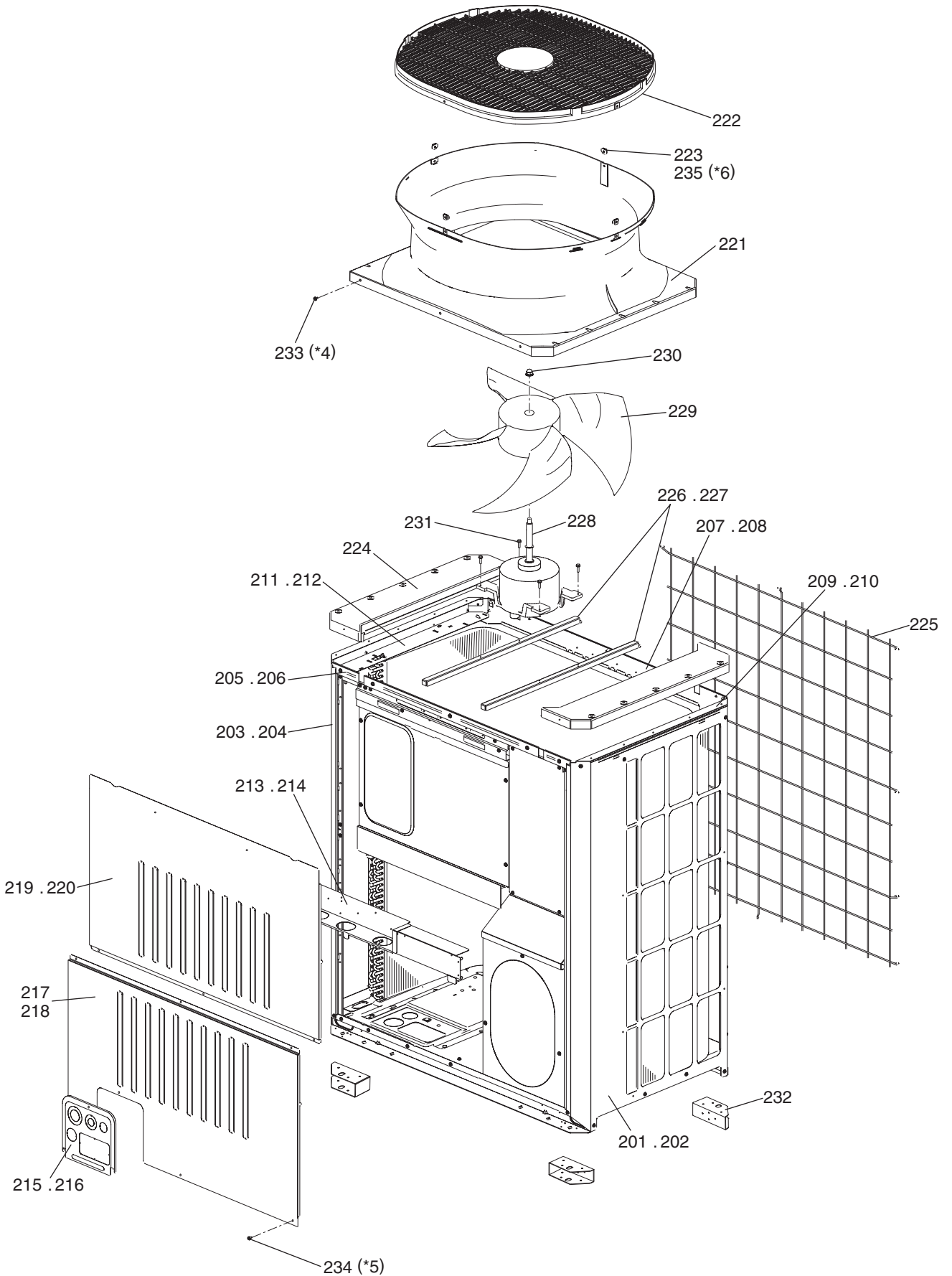

*4 38 WFT Screws (part No.233),
 *5 95 H Screws (part No.234),
 *6 4 WFT Screws (part No.235)

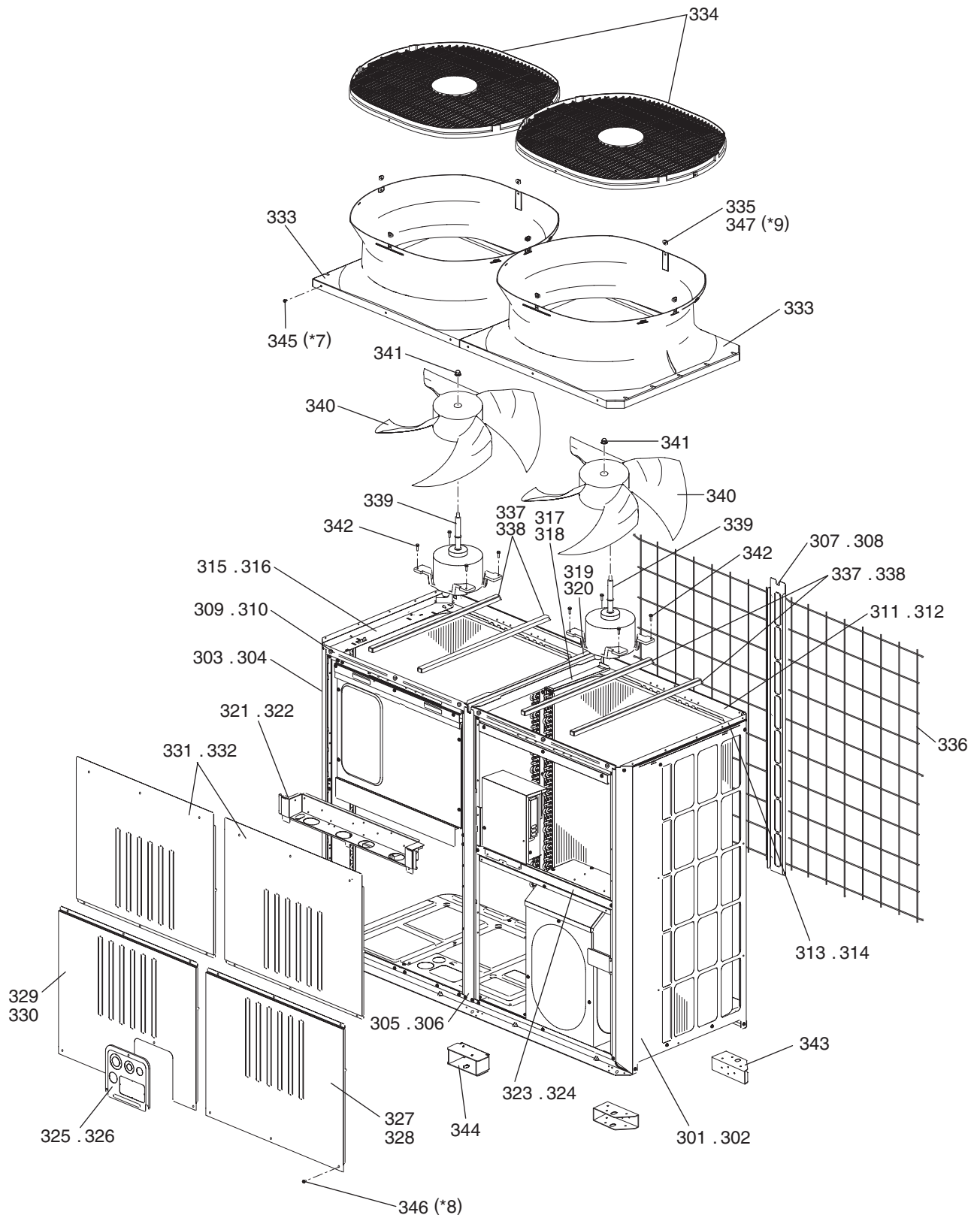

- *7 52 WFT Screws (part No.345),
- *8 138 H Screws (part No.346),
- *9 8 WFT Screws (part No.347)

No.	Part No.	G : RoHS Apply Only W : RoHS Apply by Running Change		Spec.	PURY-P450YLM-A1	PURY-P450YLM-A1-BS	PURY-P500YLM-A1	PURY-P500YLM-A1-BS	Dwg. No.	Notes for the models	Revision info.
			Part Name								
301	R63 052 652	G	Panel R		1	1			KB02A370G05		
302	R63 053 652	G	Panel R	BS		1	1		KB02A370G06		
303	R63 050 652	G	Panel L		1	1			KB02A369G07		
304	R63 051 652	G	Panel L	BS		1	1		KB02A369G08		
305	R61 022 626	G	Pillar assy MF		1	1			KD00R845G09		
306	R61 023 626	G	Pillar assy MF	BS		1	1		KD00R845G10		
307	R61 030 626	G	Pillar assy MB		1	1			KD02M109G01		
308	R61 031 626	G	Pillar assy MB	BS		1	1		KD02M109G02		
309	R61 061 162	G	Frame assy F		1	1			KD00L182G03		
310	R61 094 162	G	Frame assy F	BS		1	1		KD00L182G07		
311	R61 012 160	G	Frame assy B		1	1			KJ00C487G01		
312	R61 013 160	G	Frame assy B	BS		1	1		KJ00C487G02		
313	R61 096 162	G	Frame assy LR		1	1			KJ00C486G03		
314	R61 097 162	G	Frame assy LR	BS		1	1		KJ00C486G04		
315	R61 098 162	G	Frame assy L		1	1			KJ00C488G03		
316	R61 099 162	G	Frame assy L	BS		1	1		KJ00C488G04		
317	R61 012 499	G	Plate HEX assy		1	1			KJ00C692G01		
318	R61 013 499	G	Plate HEX assy	BS		1	1		KJ00C692G02		
319	R61 072 162	G	Frame MT		1	1			KB02J833H01		
320	R61 073 162	G	Frame MT	BS		1	1		KB02J833G01		
321	R61 090 162	G	Frame assy M		1	1			KD00L159G11		
322	R61 089 162	G	Frame assy M	BS		1	1		KD00L159G12		
323	R61 058 162	G	Frame MR		1	1			KD02G743H04		
324	R61 059 162	G	Frame MR	BS		1	1		KD02G743G02		
325	R61 095 690	G	Piping cover		1	1			KB02L001G07		
326	R61 094 690	G	Piping cover	BS		1	1		KB02L001G08		
327	R61 212 651	G	Panel FBR		1	1			KB02J838H04		
328	R61 213 651	G	Panel FBR	BS		1	1		KB02J838G06		
329	R61 182 651	G	Panel FBL		1	1			KB02J837H02		
330	R61 183 651	G	Panel FBL	BS		1	1		KB02J837G04		
331	R61 177 651	G	Panel FU		2	2			KB02J839H01		
332	R61 178 651	G	Panel FU	BS		2	2		KB02J839G02		
333	R61 005 119	G	Bell mouth		2	2	2	2	KB25A367H03		
334	R11 003 009	G	Fan guard		2	2	2	2	KB25V019H01		
335	R61 009 669	G	Plate Fan guard		8	8	8	8	KD02D205H02		
336	R61 010 611	G	Fin guard B		2	2	2	2	KB07N272G01		
337	R61 016 140	G	Base fan		4	4			KD02D026H01		
338	R61 017 140	G	Base fan	BS		4	4		KD02D026G04		
339	R61 167 220	G	Motor	L-920-B4-1 Y AC380-460-920W	2	2	2	2	P780225X02		
340	R63 4H6 300	G	Fan		2	2	2	2	KB25A009H04		
341	R63 4H6 122	G	Box nut	M12 CH	2	2	2	2	P552000X01		
342	R61 028 087	G	Upset Screw	M6 x 22	8	8	8	8	P516049X01		
343	R61 016 130	G	Attachment leg		4	4	4	4	KD02T773G01		
344	R61 025 130	G	Attachment leg	XL	2	2	2	2	KD02T774G01		
345	R63 006 087	G	WFT Screw	M5 x 12 (30pcs)	2	2	2	2	KB00H418G01	*7	

No.	Part No.	G : RoHS Apply Only W : RoHS Apply by Running Change		Spec.	PURY-P450YLM-A1	PURY-P450YLM-A1-BS	PURY-P500YLM-A1	PURY-P500YLM-A1-BS			Dwg. No.	Notes for the models	Revision info.
		Part Name											
346	R63 007 087	G	H Screw	M5 x 10 KNURLED (30pcs)	5	5	5	5			KB00H418G14	*8	
347	R63 029 087	G	WFT Screw	M5 x 16 (10pcs)	1	1	1	1			KD00H026G01	*9	

PURY-P200YLM-A1(-BS)
 PURY-P250YLM-A1(-BS)

FUNCTIONAL PARTS (1)

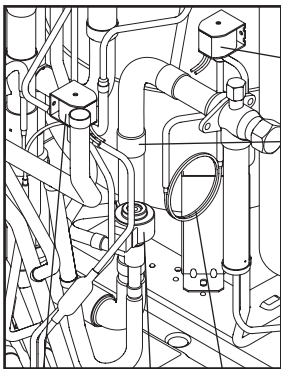
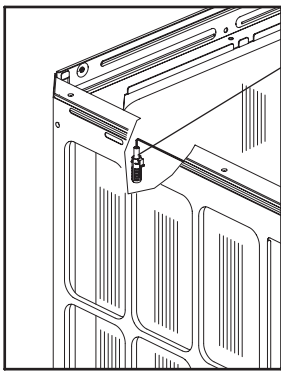

428 431 416
 430 432

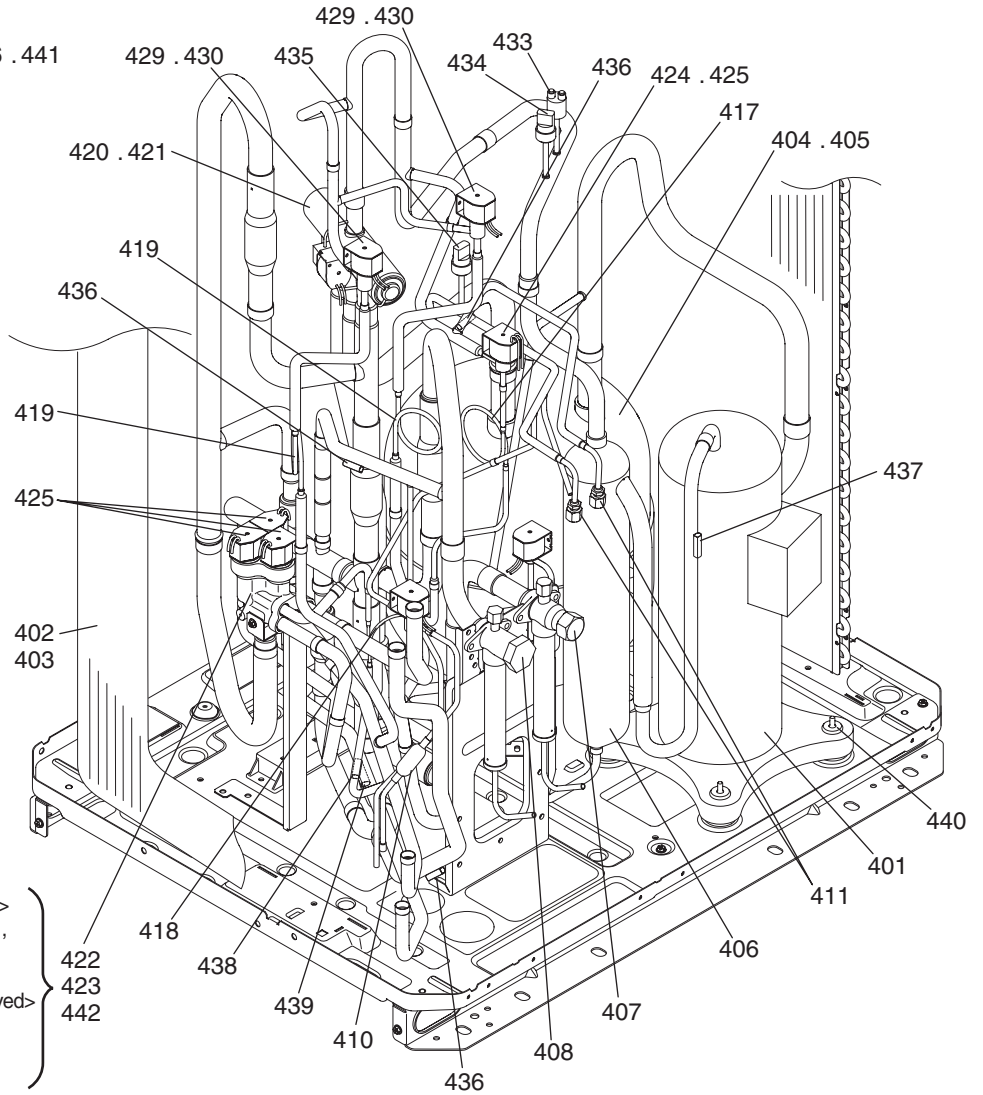

<To replace parts with the HEX removed>
 Individual replacement of parts 422, 423, and 442 is possible.

<To replace parts without the HEX removed>
 (*10, *11)
 Replace parts 422, 423, and 442 with a service pipe assembly 443 (Figure 1).

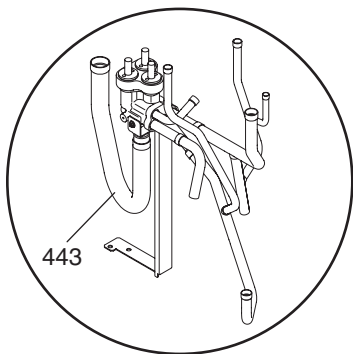
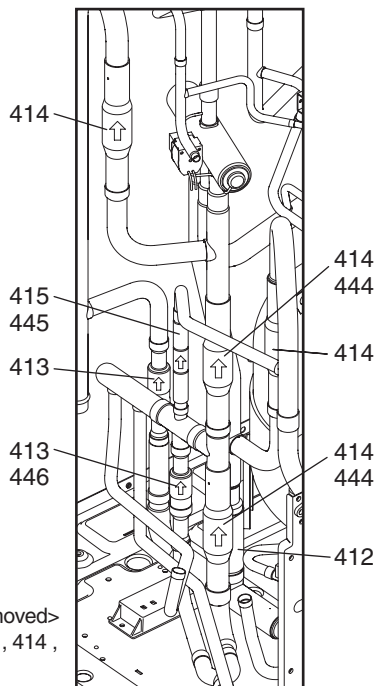
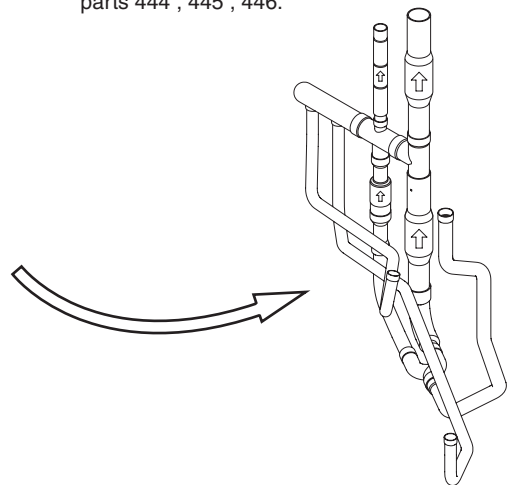

Figure 1

<To replace parts with the HEX removed>
 Individual replacement of parts 413, 414, and 415 is possible.



<To replace parts without the HEX removed>
 (*10, *12)
 Remove the solenoid valve block assembly (Figure 1), take the check valve assembly (see figure below) out of the unit, and replace parts 444, 445, 446.



*10 Refer to the replacement instructions provided with parts 443, 444, 445, and 446 for details.

*11 A solenoid valve block assy and a sheet of replacement instructions are included with Solenoid valve block service parts kit (No. 443).
 *12 A check valve and a sheet of replacement instructions are included with Service parts with instructions (No. 444, 445, 446).

No.	Part No.	G : RoHS Apply Only W : RoHS Apply by Running Change	Part Name	Spec.	PURY-P200YLM-A1	PURY-P200YLM-A1-BS	PURY-P250YLM-A1	PURY-P250YLM-A1-BS		Dwg. No.	Notes for the models	Revision info.
401	R69 103 478	G	Scroll compressor	ENB62FB-YE	1	1	1	1		EP10132B04		
402	R61 874 480	G	Heat exchanger	3L	1		1			KJ01C626G05		
403	R61 876 480	G	Heat exchanger	3L BS		1		1		KJ01C626G06		
404	R61 079 484	G	Accumulator assy		1		1			KB54B375G13		
405	R61 080 484	G	Accumulator assy	BS		1		1		KB54B375G14		
406	R61 044 487	G	Oil separator assy		1	1	1	1		KJ00L830G02		
407	R61 002 540	G	Valve	VSAMH8SSCM-A	1	1	1	1		P636343X01	<(LP)BV1>	
408	R63 007 538	G	Valve	VSAMH8SSCM-LA1	1	1	1	1		P636353X01	<(HP)BV2>	
409	R61 008 454	G	Strainer	25.4D	1	1	1	1		KB48K250G01	<ST1>	
410	R63 155 454	G	Strainer	6.35D	1	1	1	1		W882822G01	<ST18>	
411	R61 004 413	G	Check joint L		2	2	2	2		P666013X01	<(HP)CJ1,(LP)CJ2>	
412	R61 013 418	G	Check valve	YBV-22YA7GMD-1	1	1	1	1		P633132X01	<CV2a>	
413	R61 019 418	G	Check valve	UCV-A1507DQ4	2	2	2	2		P633135X01	<CV3a,CV9a>	
414	R61 002 418	G	Check valve	YBV-22Y9GMD-1	4	4	4	4		P639183X01	<CV4a,CV5a,CV7a,CV8a>	
415	R61 005 418	G	Check valve	YAV-P11Y5HMD-1	1	1	1	1		P633133X01	<CV6a>	
416	R63 002 425	G	Capillary tube assy		1	1	1	1		KB49F229G01	<CP1>	
417	R61 008 425	G	Capillary tube assy		1	1	1	1		KB49H700G01	<CP2>	
418	R61 022 425	G	Capillary tube assy		1	1	1	1		KD49F641G01	<CP3>	
419	R61 013 425	G	Capillary tube assy		2	2	2	2		KB49K872G01	<CP4,CP5>	
420	R61 013 403	G	Four way valve	STF-H0731	1	1	1	1		P633130X01	<21S4a>	
421	R61 009 242	G	Four way valve coil	STF-H01AJ1737A1	1	1	1	1		P472092X01	<21S4a>	
422	R61 038 232	G	Valve block assy	3SV	1	1	1	1		KB00T028G02		
423	R63 6A7 235	G	Solenoid valve	ACS-BPMD-8	3	3	3	3		P631310X01	<SV4a,SV4b,SV4d>	
424	R63 Y07 232	G	Solenoid valve	ATS-B7SMD-1	1	1	1	1		P631291X01	<SV9>	
425	R63 Y18 243	G	Solenoid valve coil	A22-1B02B-1	4	4	4	4		P472012X01	<SV4a,SV4b,SV4d,SV9>	
426	R63 046 232	G	Solenoid valve	FD2A77	1	1	1	1		P631312X01	<SV1a>	
427	R63 032 243	G	Solenoid valve coil	FQ-G625	1	1	1	1		P472070X01	<SV1a>	
428	R63 027 232	G	Solenoid valve	VPV-L202D	1	1	1	1		P631296X01	<SV5b>	
429	R63 001 921	G	Solenoid valve	VPV-603DQ3	2	2	2	2		P631295X01	<SV10,SV11>	
430	R61 015 243	G	Solenoid valve coil	VPV-MOAJ512B1	3	3	3	3		P472048X01	<SV5b,SV10,SV11>	
431	R61 036 401	G	Linear expansion valve	PAM-BBOYGMD-1	1	1	1	1		P632504X01	<LEV5a>	
432	R61 030 243	G	LEV coil	PAM-MD12MD-6	1	1	1	1		P472081X01	<LEV5a>	
433	R63 Y11 208	G	Pressure switch	ACB-1UB28W	1	1	1	1		P426320X01	<63H1>	
434	R63 049 288	G	Pressure sensor	HP	1	1	1	1		KB00H904G20	<63HS1>	
435	R63 050 288	G	Pressure sensor	LP	1	1	1	1		KB00H904G21	<63LS>	
436	R61 060 200	G	Thermistor		4	4	4	4		P418065X01	<TH3,TH5,TH7,TH9>	
437	R63 911 202	G	Thermistor		1	1	1	1		P425416X02	<TH4>	
438	R63 800 202	G	Thermistor		1	1	1	1		P425494X01	<TH6>	
439	R63 172 200	G	Thermistor		1	1	1	1		P418098X01	<TH11>	
440	R63 852 860	G	Rubber mount		4	4	4	4		W897574H01	For compressor	
441	R61 001 310	G	Sensor holder		1	1	1	1		KB25B471H03	<TH7>	
442	R63 6A7 245	G	SV tightening element		1	1	1	1		W909209G01		
443	R61 062 232	G	SV block service parts kit		1	1	1	1		KB00S879G21	*11	
444	R61 020 418	G	Check valve 1	(with instructions)	2	2	2	2		KB00S879G23	<CV4a,CV8a> *12	
445	R61 021 418	G	Check valve 2	(with instructions)	1	1	1	1		KB00S879G24	<CV6a> *12	

PURY-P300YLM-A1(-BS)
 PURY-P350YLM-A1(-BS)
 PURY-P400YLM-A1(-BS)

FUNCTIONAL PARTS (2)

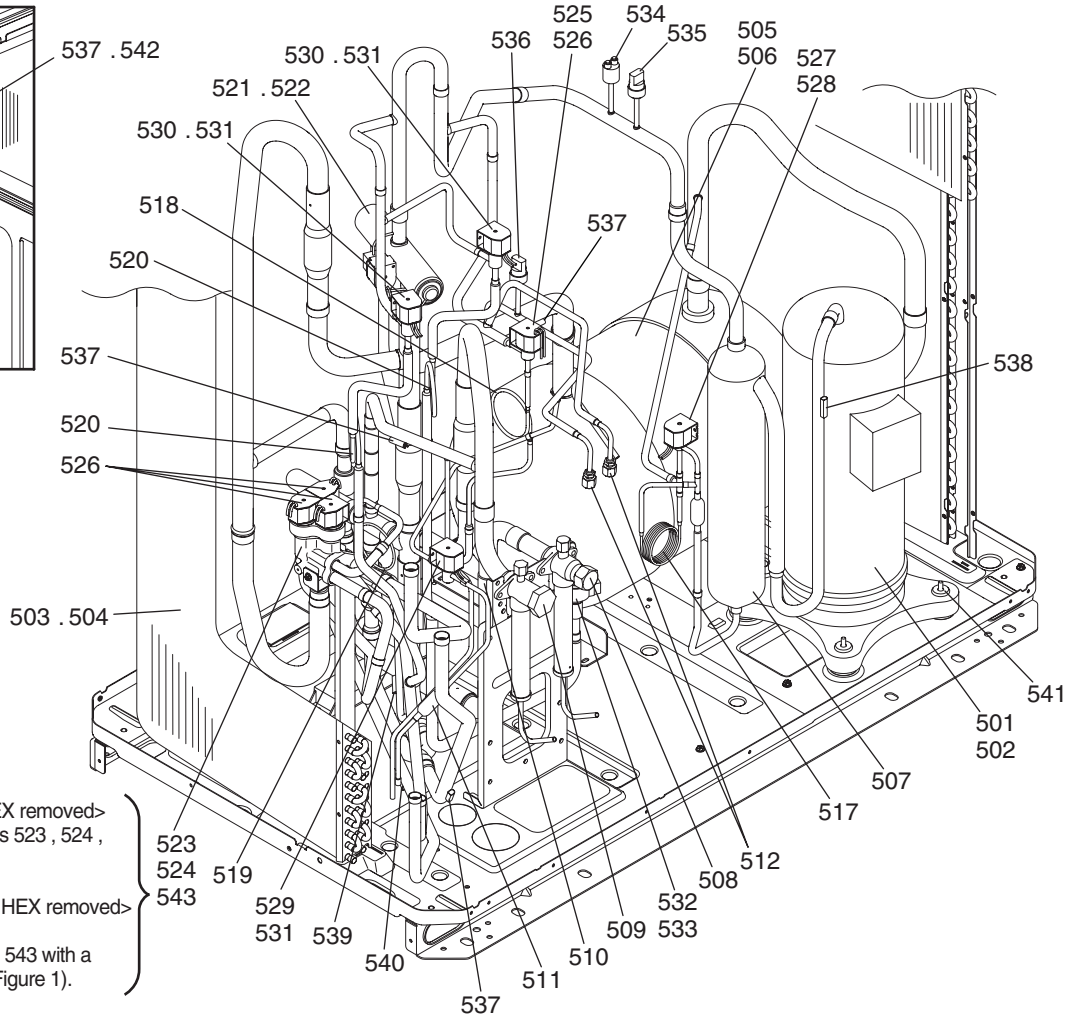
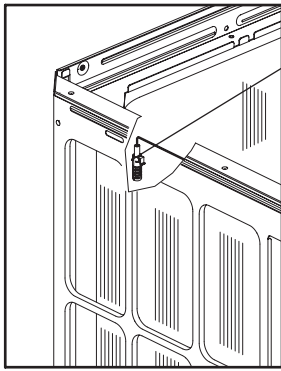

<To replace parts with the HEX removed>
 Individual replacement of parts 523, 524, and 543 is possible.

<To replace parts without the HEX removed> (*13, *14)
 Replace parts 523, 524, and 543 with a service pipe assembly 544 (Figure 1).

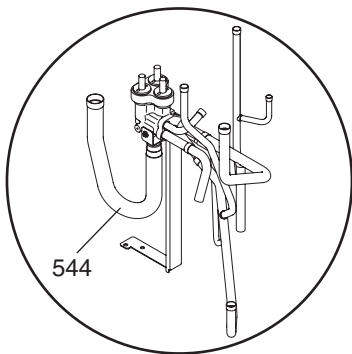
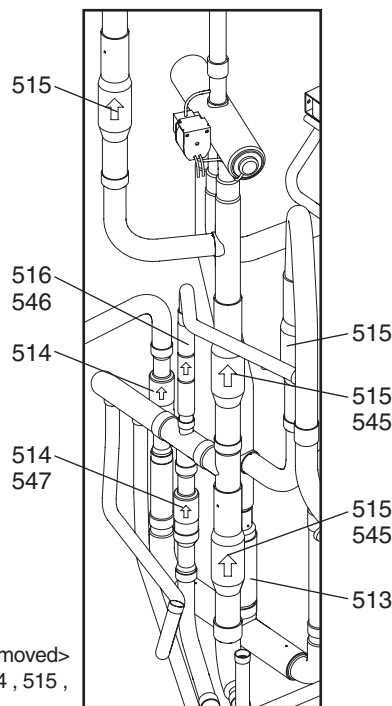
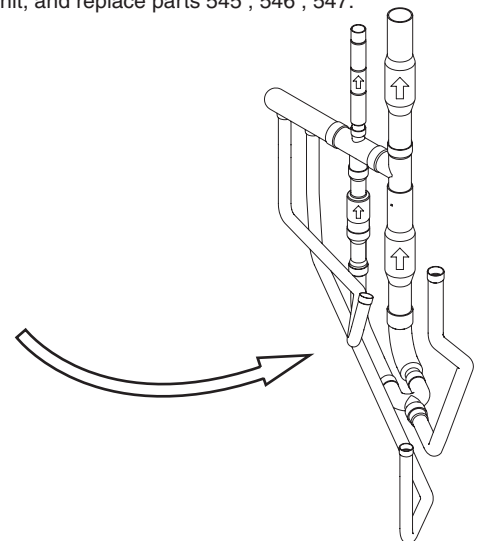

Figure 1

<To replace parts with the HEX removed>
 Individual replacement of parts 514, 515, and 516 is possible.



<To replace parts without the HEX removed> (*13, *15)
 Remove the solenoid valve block assembly (Figure 1), take the check valve assembly (see figure below) out of the unit, and replace parts 545, 546, 547.



*13 Refer to the replacement instructions provided with parts 544, 545, 546, and 547 for details.

*14 A solenoid valve block assy and a sheet of replacement instructions are included with Solenoid valve block service parts kit (No. 544).

*15 A check valve and a sheet of replacement instructions are included with Service parts with instructions (No. 545, 546, 547).

PURY-P300YLM-A1(-BS)
PURY-P350YLM-A1(-BS)
PURY-P400YLM-A1(-BS)

FUNCTIONAL PARTS (2)

No.	Part No.	G : RoHS Apply Only W : RoHS Apply by Running Change	Part Name	Spec.	PURY-P300YLM-A1	PURY-P350YLM-A1-BS	PURY-P350YLM-A1	PURY-P350YLM-A1-BS	PURY-P400YLM-A1	PURY-P400YLM-A1-BS	Dwg. No.	Notes for the models	Revision info.
501	R69 104 478	G	Scroll compressor	HNB83FB-YE	1	1	1	1			EP10136B03		
502	R69 118 478	G	Scroll compressor	HNB84FC-YE					1	1	EP10126B04		
503	R61 878 480	G	Heat exchanger	3L	1		1		1		KD01R776G03		
504	R61 879 480	G	Heat exchanger	3L BS		1		1		1	KD01R776G04		
505	R61 118 484	G	Accumulator assy		1		1		1		KB54B479G33		
506	R61 119 484	G	Accumulator assy	BS		1		1		1	KB54B479G34		
507	R61 044 487	G	Oil separator assy		1	1	1	1	1	1	KJ00L830G02		
508	R61 002 540	G	Valve	VSAMH8SSCM-A	1	1	1	1	1	1	P636343X01	<(LP)BV1>	
509	R63 007 538	G	Valve	VSAMH8SSCM-LA1	1	1	1	1	1	1	P636353X01	<(HP)BV2>	
510	R61 008 454	G	Strainer	25.4D	1	1	1	1	1	1	KB48K250G01	<ST1>	
511	R63 155 454	G	Strainer	6.35D	1	1	1	1	1	1	W882822G01	<ST18>	
512	R61 004 413	G	Check joint L		2	2	2	2	2	2	P666013X01	<(HP)CJ1,(LP)CJ2>	
513	R61 013 418	G	Check valve	YBV-22YA7GMD-1	1	1	1	1	1	1	P633132X01	<CV2a>	
514	R61 019 418	G	Check valve	UCV-A1507DQ4	2	2	2	2	2	2	P633135X01	<CV3a,CV9a>	
515	R61 002 418	G	Check valve	YBV-22Y9GMD-1	4	4	4	4	4	4	P639183X01	<CV4a,CV5a,CV7a,CV8a>	
516	R61 005 418	G	Check valve	YAV-P11Y5HMD-1	1	1	1	1	1	1	P633133X01	<CV6a>	
517	R63 R55 425	G	Capillary tube assy		1	1	1	1	1	1	W905191G02	<CP1>	
518	R61 008 425	G	Capillary tube assy		1	1	1	1	1	1	KB49H700G01	<CP2>	
519	R61 022 425	G	Capillary tube assy		1	1	1	1	1	1	KD49F641G01	<CP3>	
520	R63 021 425	G	Capillary tube assy		2	2	2	2	2	2	KD49D414G01	<CP4,CP5>	
521	R61 013 403	G	Four way valve	STF-H0731	1	1	1	1	1	1	P633130X01	<21S4a>	
522	R61 009 242	G	Four way valve coil	STF-H01AJ1737A1	1	1	1	1	1	1	P472092X01	<21S4a>	
523	R61 038 232	G	Valve block assy	3SV	1	1	1	1	1	1	KB00T028G02		
524	R63 6A7 235	G	Solenoid valve	ACS-BPMD-8	3	3	3	3	3	3	P631310X01	<SV4a,SV4b,SV4d>	
525	R63 Y07 232	G	Solenoid valve	ATS-B7SMD-1	1	1	1	1	1	1	P631291X01	<SV9>	
526	R63 Y18 243	G	Solenoid valve coil	A22-1B02B-1	4	4	4	4	4	4	P472012X01	<SV4a,SV4b,SV4d,SV9>	
527	R63 046 232	G	Solenoid valve	FD2A77	1	1	1	1	1	1	P631312X01	<SV1a>	
528	R63 032 243	G	Solenoid valve coil	FQ-G625	1	1	1	1	1	1	P472070X01	<SV1a>	
529	R63 027 232	G	Solenoid valve	VPV-L202D	1	1	1	1	1	1	P631296X01	<SV5b>	
530	R63 001 921	G	Solenoid valve	VPV-603DQ3	2	2	2	2	2	2	P631295X01	<SV10,SV11>	
531	R61 015 243	G	Solenoid valve coil	VPV-MOAJ512B1	3	3	3	3	3	3	P472048X01	<SV5b,SV10,SV11>	
532	R61 036 401	G	Linear expansion valve	PAM-BBOYGMD-1	1	1	1	1	1	1	P632504X01	<LEV5a>	
533	R61 030 243	G	LEV coil	PAM-MD12MD-6	1	1	1	1	1	1	P472081X01	<LEV5a>	
534	R63 Y11 208	G	Pressure switch	ACB-1UB28W	1	1	1	1	1	1	P426320X01	<63H1>	
535	R63 049 288	G	Pressure sensor	HP	1	1	1	1	1	1	KB00H904G20	<63HS1>	
536	R63 050 288	G	Pressure sensor	LP	1	1	1	1	1	1	KB00H904G21	<63LS>	
537	R61 060 200	G	Thermistor		4	4	4	4	4	4	P418065X01	<TH3,TH5,TH7,TH9>	
538	R63 911 202	G	Thermistor		1	1	1	1	1	1	P425416X02	<TH4>	
539	R63 800 202	G	Thermistor		1	1	1	1	1	1	P425494X01	<TH6>	
540	R63 172 200	G	Thermistor		1	1	1	1	1	1	P418098X01	<TH11>	
541	R63 852 860	G	Rubber mount		4	4	4	4	4	4	W897574H01	For compressor	
542	R61 001 310	G	Sensor holder		1	1	1	1	1	1	KB25B471H03	<TH7>	
543	R63 6A7 245	G	SV tightening element		1	1	1	1	1	1	W909209G01		
544	R61 063 232	G	SV block service parts kit		1	1	1	1	1	1	KB00S879G22	*14	
545	R61 020 418	G	Check valve 1	(with instructions)	2	2	2	2	2	2	KB00S879G23	<CV4a,CV8a> *15	

PURY-P300YLM-A1(-BS)
 PURY-P350YLM-A1(-BS)
 PURY-P400YLM-A1(-BS)

FUNCTIONAL PARTS (2)

No.	Part No.	G : RoHS Apply Only W : RoHS Apply by Running Change		Spec.	PURY-P300YLM-A1	PURY-P350YLM-A1	PURY-P350YLM-A1	PURY-P350YLM-A1	PURY-P400YLM-A1	PURY-P400YLM-A1	Dwg. No.	Notes for the models	Revision info.
		Part Name											
546	R61 021 418	G	Check valve 2	(with instructions)	1	1	1	1	1	1	KB00S879G24	<CV6a> *15	
547	R61 022 418	G	Check valve 3	(with instructions)	1	1	1	1	1	1	KB00S879G25	<CV9a> *15	

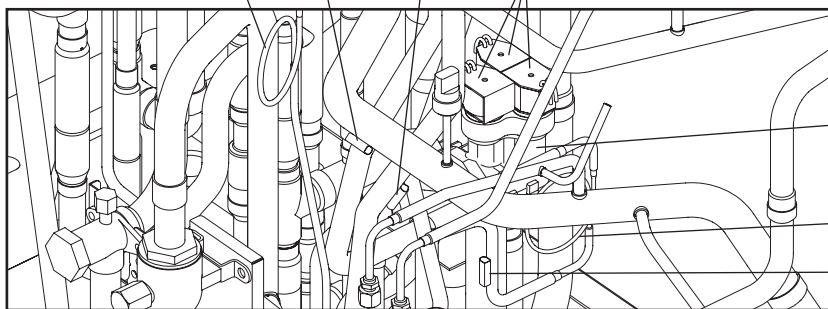
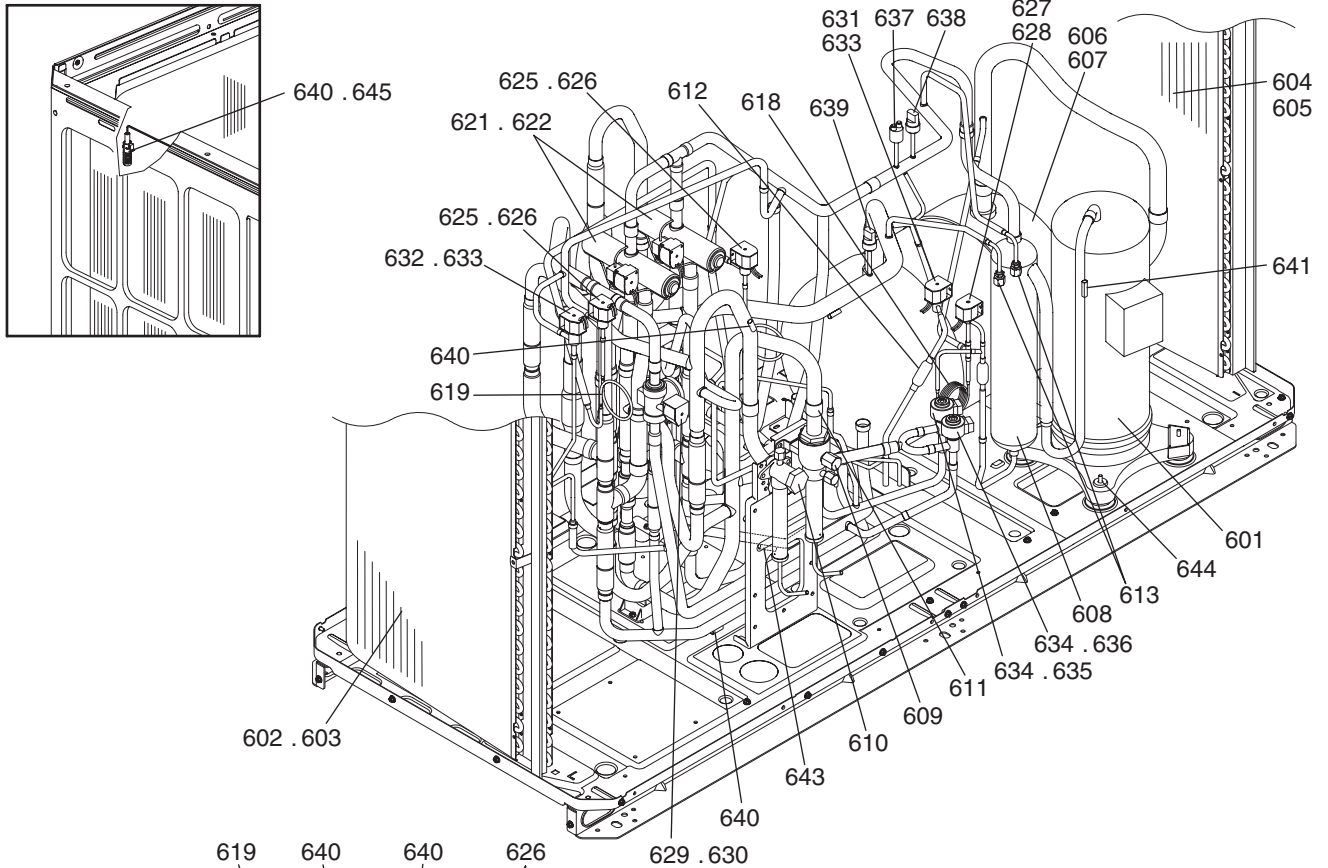

<To replace parts with the HEX removed>
 Individual replacement of parts 623, 624, and 646 is possible.

<To replace parts without the HEX removed (*16, *17)>
 Replace parts 623, 624, and 646 with a service pipe assembly 647 (Figure 1).

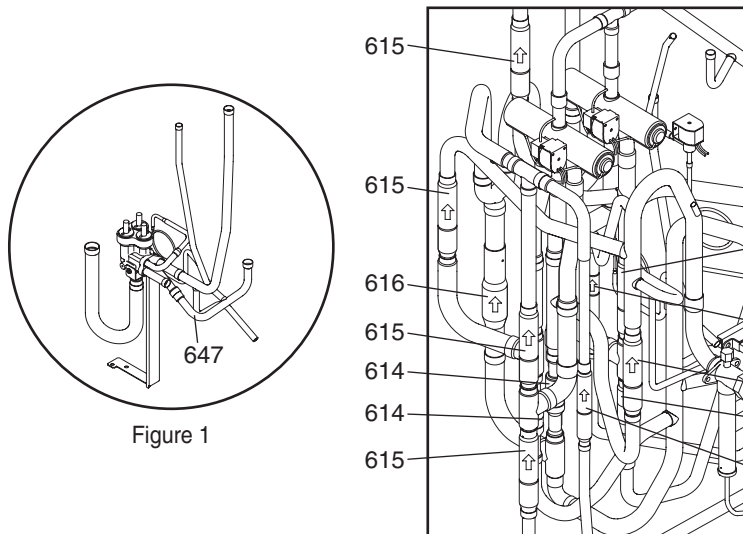

<To replace parts without the HEX removed (*16, *18)>
 Remove the solenoid valve block assembly (Figure 1), take the check valve assembly (see figure below) out of the unit, and replace parts 648, 649, 650.

<To replace parts with the HEX removed>
 Individual replacement of parts 614, 615, and 617 is possible.

*16 Refer to the replacement instructions provided with parts 647, 648, 649, and 650 for details.
 *17 A solenoid valve block assy and a sheet of replacement instructions are included with Solenoid valve block service parts kit (No. 647).
 *18 A check valve and a sheet of replacement instructions are included with Service parts with instructions (No. 648, 649, 650).

No.	Part No.	G : RoHS Apply Only W : RoHS Apply by Running Change		Spec.	PURY-P450YLM-A1	PURY-P450YLM-A1-BS	PURY-P500YLM-A1	PURY-P500YLM-A1-BS	Dwg. No.	Notes for the models	Revision info.
			Part Name								
601	R69 118 478	G	Scroll compressor	HNB84FC-YE	1	1	1	1	EP10126B04		
602	R61 642 480	G	Heat exchanger L	3L	1		1		KD01R771G01		
603	R61 643 480	G	Heat exchanger L	3L BS		1		1	KD01R771G02		
604	R63 644 480	G	Heat exchanger R	3L	1		1		KD01R885G01		
605	R63 645 480	G	Heat exchanger R	3L BS		1		1	KD01R885G02		
606	R61 120 484	G	Accumulator assy		1		1		KB54B479G35		
607	R61 121 484	G	Accumulator assy	BS		1		1	KB54B479G36		
608	R61 044 487	G	Oil separator assy		1	1	1	1	KJ00L830G02		
609	R61 009 410	G	Ball valve	SBV-JA10YGME-3	1	1	1	1	P636358X01	<(LP)BV1>	
610	R63 007 538	G	Valve	VSAMH8SSCM-LA1	1	1	1	1	P636353X01	<(HP)BV2>	
611	R61 008 454	G	Strainer	25.4D	1	1	1	1	KB48K250G01	<ST1>	
612	R63 A42 454	G	Strainer	9.52D	1	1	1	1	W882823G01	<ST18>	
613	R61 004 413	G	Check joint L		2	2	2	2	P666013X01	<(HP)CJ1,(LP)CJ2>	
614	R61 019 418	G	Check valve	UCV-A1507DQ4	3	3	3	3	P633135X01	<CV2a,CV2b,CV8a>	
615	R61 003 418	G	Check valve	LCVP15-7M	6	6	6	6	P639180X01	<CV4a,CV4b,CV5a,CV5b,CV7a,CV7b>	
616	R61 002 418	G	Check valve	YBV-22Y9GMD-1	1	1	1	1	P639183X01	<CV3a>	
617	R61 005 418	G	Check valve	YAV-P11Y5HMD-1	2	2	2	2	P633133X01	<CV6a,CV6b>	
618	R63 R55 425	G	Capillary tube assy		1	1	1	1	W905191G02	<CP1>	
619	R61 008 425	G	Capillary tube assy		2	2	2	2	KB49H700G01	<CP2,CP4>	
620	R61 022 425	G	Capillary tube assy		1	1	1	1	KD49F641G01	<CP3>	
621	R61 013 403	G	Four way valve	STF-H0731	2	2	2	2	P633130X01	<21S4 a ,21S4b>	
622	R61 009 242	G	Four way valve coil	STF-H01AJ1737A1	2	2	2	2	P472092X01	<21S4 a ,21S4b>	
623	R61 038 232	G	Valve block assy	3SV	1	1	1	1	KB00T028G02		
624	R63 6A7 235	G	Solenoid valve	ACS-BPMD-8	3	3	3	3	P631310X01	<SV4a,SV4b,SV4d>	
625	R63 Y07 232	G	Solenoid valve	ATS-B7SMD-1	2	2	2	2	P631291X01	<SV9,SV10>	
626	R63 Y18 243	G	Solenoid valve coil	A22-1B02B-1	5	5	5	5	P472012X01	<SV4a,SV4b,SV4d,SV9,SV10>	
627	R63 046 232	G	Solenoid valve	FDFA2A77	1	1	1	1	P631312X01	<SV1a>	
628	R63 032 243	G	Solenoid valve coil	FQ-G625	1	1	1	1	P472070X01	<SV1a>	
629	R63 P89 232	G	Solenoid valve	SR66PF-06WR	1	1	1	1	P631278X01	<SV4c>	
630	R61 007 243	G	Solenoid valve coil	SR10D-20L-3	1	1	1	1	P472030X02	<SV4c>	
631	R63 027 232	G	Solenoid valve	VPV-L202D	1	1	1	1	P631296X01	<SV5b>	
632	R63 001 921	G	Solenoid valve	VPV-603DQ3	1	1	1	1	P631295X01	<SV11>	
633	R61 015 243	G	Solenoid valve coil	VPV-MOAJ512B1	2	2	2	2	P472048X01	<SV5b,SV11>	
634	R61 036 401	G	Linear expansion valve	PAM-BBOYGMD-1	2	2	2	2	P632504X01	<LEV5a,LEV5b>	
635	R61 030 243	G	LEV coil	PAM-MD12MD-6	1	1	1	1	P472081X01	<LEV5a>	
636	R61 022 243	G	LEV coil	PAM-MD12MD-3	1	1	1	1	P472061X02	<LEV5b>	
637	R63 Y11 208	G	Pressure switch	ACB-1UB28W	1	1	1	1	P426320X01	<63H1>	
638	R63 052 288	G	Pressure sensor	HP	1	1	1	1	KB00H904G22	<63HS1>	
639	R63 053 288	G	Pressure sensor	LP	1	1	1	1	KB00H904G23	<63LS>	
640	R61 060 200	G	Thermistor		5	5	5	5	P418065X01	<TH3,TH5,TH7,TH9,TH12>	
641	R63 911 202	G	Thermistor		1	1	1	1	P425416X02	<TH4>	
642	R63 800 202	G	Thermistor		1	1	1	1	P425494X01	<TH6>	
643	R63 172 200	G	Thermistor		1	1	1	1	P418098X01	<TH11>	
644	R63 852 860	G	Rubber mount		4	4	4	4	W897574H01	For compressor	
645	R61 001 310	G	Sensor holder		1	1	1	1	KB25B471H03	<TH7>	

No.	Part No.	G : RoHS Apply Only W : RoHS Apply by Running Change	Part Name	Spec.	PURY-P450YLM-A1	PURY-P450YLM-A1-BS	PURY-P500YLM-A1	PURY-P500YLM-A1-BS		Dwg. No.	Notes for the models	Revision info.
646	R63 6A7 245	G	SV tightening element		1	1	1	1		W909209G01		
647	R61 064 232	G	SV block service parts kit		1	1	1	1		KB00S879G26	*17	
648	R61 023 418	G	Check valve 1	(with instructions)	1	1	1	1		KB00S879G27	<CV4a> *18	
649	R61 024 418	G	Check valve 2	(with instructions)	1	1	1	1		KB00S879G28	<CV6a> *18	
650	R61 025 418	G	Check valve 3	(with instructions)	1	1	1	1		KB00S879G29	<CV8a> *18	

PURY-P200,P250YLM-A1(-BS)
PURY-P300,P350YLM-A1(-BS)
PURY-P400,P450,P500YLM-A1(-BS)

CONTROL BOX PARTS

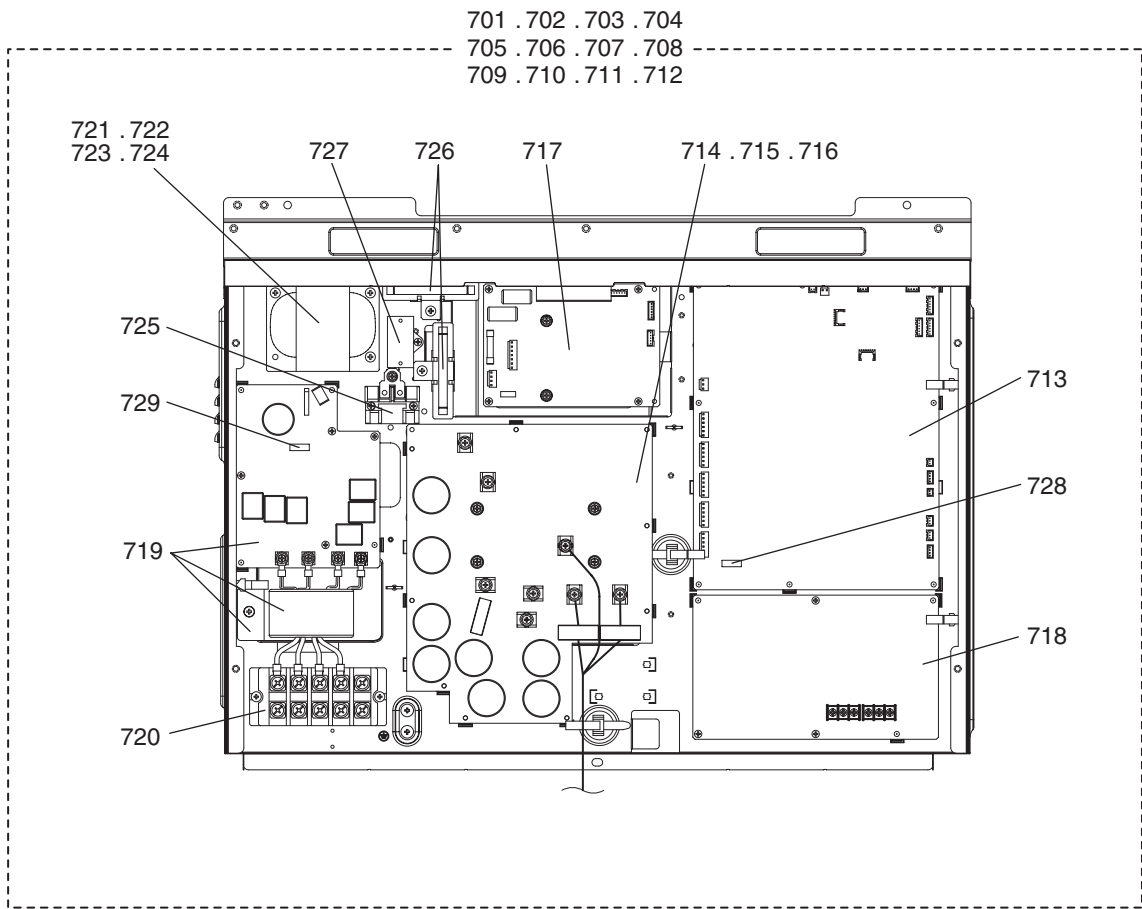

PURY-P200,P250YLM-A1(-BS)
 PURY-P300,P350YLM-A1(-BS)
 PURY-P400,P450,P500YLM-A1(-BS)

CONTROL BOX PARTS

No.	Part No.	G : RoHS Apply Only W : RoHS Apply by Running Change	Part Name	Spec.	PURY-P200YLM-A1	PURY-P200YLM-A1-BS	PURY-P250YLM-A1	PURY-P250YLM-A1-BS	PURY-P300YLM-A1	PURY-P300YLM-A1-BS	Dwg. No.	Notes for the models	Revision info.
701	R61 584 305	G	Control box	R-P200	1						KE80C542GA3		
702	R61 585 305	G	Control box	R-P200 BS		1					KE80C542GA4		
703	R61 586 305	G	Control box	R-P250			1				KE80C542GA5		
704	R61 587 305	G	Control box	R-P250 BS				1			KE80C542GA6		
705	R61 588 305	G	Control box	R-P300					1		KE80C542GA7		
706	R61 589 305	G	Control box	R-P300 BS						1	KE80C542GA8		
707	R61 590 305	G	Control box	R-P350							KE80C542GA9		
708	R61 591 305	G	Control box	R-P350 BS							KE80C542GB0		
709	R61 592 305	G	Control box	R-P400							KE80C542GB1		
710	R61 593 305	G	Control box	R-P400 BS							KE80C542GB2		
711	R61 594 305	G	Control box	R-P450							KE80C542GB3		
712	R61 595 305	G	Control box	R-P450 BS							KE80C542GB4		
713	R61 308 280	G	Control board		1	1	1	1	1	1	KE80C836G05	<MAIN09>	
714	R61 299 280	G	INV board		1	1	1	1			KE80C154G15	<INV20Y>	
715	R61 302 280	G	INV board						1	1	KE80C154G16	<INV20Y>	
716	R61 303 280	G	INV board								KE80C154G17	<INV20Y>	
717	R61 304 280	G	Fan board		1	1	1	1	1	1	W652171G18	<INV/S12Y>	
718	R63 187 280	G	M-NET board		1	1	1	1	1	1	KE80C055G06	<PS-MNET-Y>	
719	R61 028 293	G	Noise filter	board,coil,plate	1	1	1	1	1	1	KE80C727G03		
720	R61 007 246	G	Terminal block		1	1	1	1	1	1	S436005H12	<TB1>	
721	R61 017 259	G	Reactor		1	1					P715458X01	<DCL>	
722	R61 027 259	G	Reactor				1	1			P715476X02	<DCL>	
723	R61 028 259	G	Reactor						1	1	P715475X02	<DCL>	
724	R61 012 259	G	Reactor								P715441X02	<DCL>	
725	R61 003 216	G	Relay		1	1	1	1	1	1	P421295X01	<72C>	
726	R61 001 234	G	Resistor		2	2	2	2	2	2	P411151X01	<R1,R5>	
727	R61 001 255	G	Capacitor assy		1	1	1	1	1	1	KE00D263G01	<C100>	
728	R61 005 239	G	Fuse	3.15A AC250V T	1	1	1	1	1	1	S423001H39		
729	R61 006 239	G	Fuse	6.3A AC250V T	1	1	1	1	1	1	S423001H42		

PURY-P200,P250YLM-A1(-BS)
PURY-P300,P350YLM-A1(-BS)
PURY-P400,P450,P500YLM-A1(-BS)

CONTROL BOX PARTS

No.	Part No.	G : RoHS Apply Only W : RoHS Apply by Running Change	Part Name	Spec.	PURY-P350YLM-A1	PURY-P350YLM-A1-BS	PURY-P400YLM-A1	PURY-P400YLM-A1-BS	PURY-P450YLM-A1	PURY-P450YLM-A1-BS	Dwg. No.	Notes for the models	Revision info.
701	R61 584 305	G	Control box	R-P200							KE80C542GA3		
702	R61 585 305	G	Control box	R-P200 BS							KE80C542GA4		
703	R61 586 305	G	Control box	R-P250							KE80C542GA5		
704	R61 587 305	G	Control box	R-P250 BS							KE80C542GA6		
705	R61 588 305	G	Control box	R-P300							KE80C542GA7		
706	R61 589 305	G	Control box	R-P300 BS							KE80C542GA8		
707	R61 590 305	G	Control box	R-P350	1						KE80C542GA9		
708	R61 591 305	G	Control box	R-P350 BS		1					KE80C542GB0		
709	R61 592 305	G	Control box	R-P400			1				KE80C542GB1		
710	R61 593 305	G	Control box	R-P400 BS				1			KE80C542GB2		
711	R61 594 305	G	Control box	R-P450					1		KE80C542GB3		
712	R61 595 305	G	Control box	R-P450 BS						1	KE80C542GB4		
713	R61 308 280	G	Control board		1	1	1	1	1	1	KE80C836G05	<MAIN09>	
714	R61 299 280	G	INV board								KE80C154G15	<INV20Y>	
715	R61 302 280	G	INV board		1	1					KE80C154G16	<INV20Y>	
716	R61 303 280	G	INV board				1	1	1	1	KE80C154G17	<INV20Y>	
717	R61 304 280	G	Fan board		1	1	1	1	1	1	W652171G18	<INV/S12Y>	
718	R63 187 280	G	M-NET board		1	1	1	1	1	1	KE80C055G06	<PS-MNET-Y>	
719	R61 028 293	G	Noise filter	board,coil,plate	1	1	1	1	1	1	KE80C727G03		
720	R61 007 246	G	Terminal block		1	1	1	1	1	1	S436005H12	<TB1>	
721	R61 017 259	G	Reactor								P715458X01	<DCL>	
722	R61 027 259	G	Reactor								P715476X02	<DCL>	
723	R61 028 259	G	Reactor								P715475X02	<DCL>	
724	R61 012 259	G	Reactor		1	1	1	1	1	1	P715441X02	<DCL>	
725	R61 003 216	G	Relay		1	1	1	1	1	1	P421295X01	<72C>	
726	R61 001 234	G	Resistor		2	2	2	2	2	2	P411151X01	<R1,R5>	
727	R61 001 255	G	Capacitor assy		1	1	1	1	1	1	KE00D263G01	<C100>	
728	R61 005 239	G	Fuse	3.15A AC250V T	1	1	1	1	1	1	S423001H39		
729	R61 006 239	G	Fuse	6.3A AC250V T	1	1	1	1	1	1	S423001H42		

PURY-P200,P250YLM-A1(-BS)
 PURY-P300,P350YLM-A1(-BS)
 PURY-P400,P450,P500YLM-A1(-BS)

CONTROL BOX PARTS

No.	Part No.	G : RoHS Apply Only W : RoHS Apply by Running Change		Spec.	PURY-P500YLM-A1	PURY-P600YLM-A1-BS					Dwg. No.	Notes for the models	Revision info.
			Part Name										
701	R61 584 305	G	Control box	R-P200							KE80C542GA3		
702	R61 585 305	G	Control box	R-P200 BS							KE80C542GA4		
703	R61 586 305	G	Control box	R-P250							KE80C542GA5		
704	R61 587 305	G	Control box	R-P250 BS							KE80C542GA6		
705	R61 588 305	G	Control box	R-P300							KE80C542GA7		
706	R61 589 305	G	Control box	R-P300 BS							KE80C542GA8		
707	R61 590 305	G	Control box	R-P350							KE80C542GA9		
708	R61 591 305	G	Control box	R-P350 BS							KE80C542GB0		
709	R61 592 305	G	Control box	R-P400							KE80C542GB1		
710	R61 593 305	G	Control box	R-P400 BS							KE80C542GB2		
711	R61 594 305	G	Control box	R-P450	1						KE80C542GB3		
712	R61 595 305	G	Control box	R-P450 BS		1					KE80C542GB4		
713	R61 308 280	G	Control board		1	1					KE80C836G05	<MAIN09>	
714	R61 299 280	G	INV board								KE80C154G15	<INV20Y>	
715	R61 302 280	G	INV board								KE80C154G16	<INV20Y>	
716	R61 303 280	G	INV board		1	1					KE80C154G17	<INV20Y>	
717	R61 304 280	G	Fan board		1	1					W652171G18	<INV/S12Y>	
718	R63 187 280	G	M-NET board		1	1					KE80C055G06	<PS-MNET-Y>	
719	R61 028 293	G	Noise filter	board,coil,plate	1	1					KE80C727G03		
720	R61 007 246	G	Terminal block		1	1					S436005H12	<TB1>	
721	R61 017 259	G	Reactor								P715458X01	<DCL>	
722	R61 027 259	G	Reactor								P715476X02	<DCL>	
723	R61 028 259	G	Reactor								P715475X02	<DCL>	
724	R61 012 259	G	Reactor		1	1					P715441X02	<DCL>	
725	R61 003 216	G	Relay		1	1					P421295X01	<72C>	
726	R61 001 234	G	Resistor		2	2					P411151X01	<R1,R5>	
727	R61 001 255	G	Capacitor assy		1	1					KE00D263G01	<C100>	
728	R61 005 239	G	Fuse	3.15A AC250V T	1	1					S423001H39		
729	R61 006 239	G	Fuse	6.3A AC250V T	1	1					S423001H42		

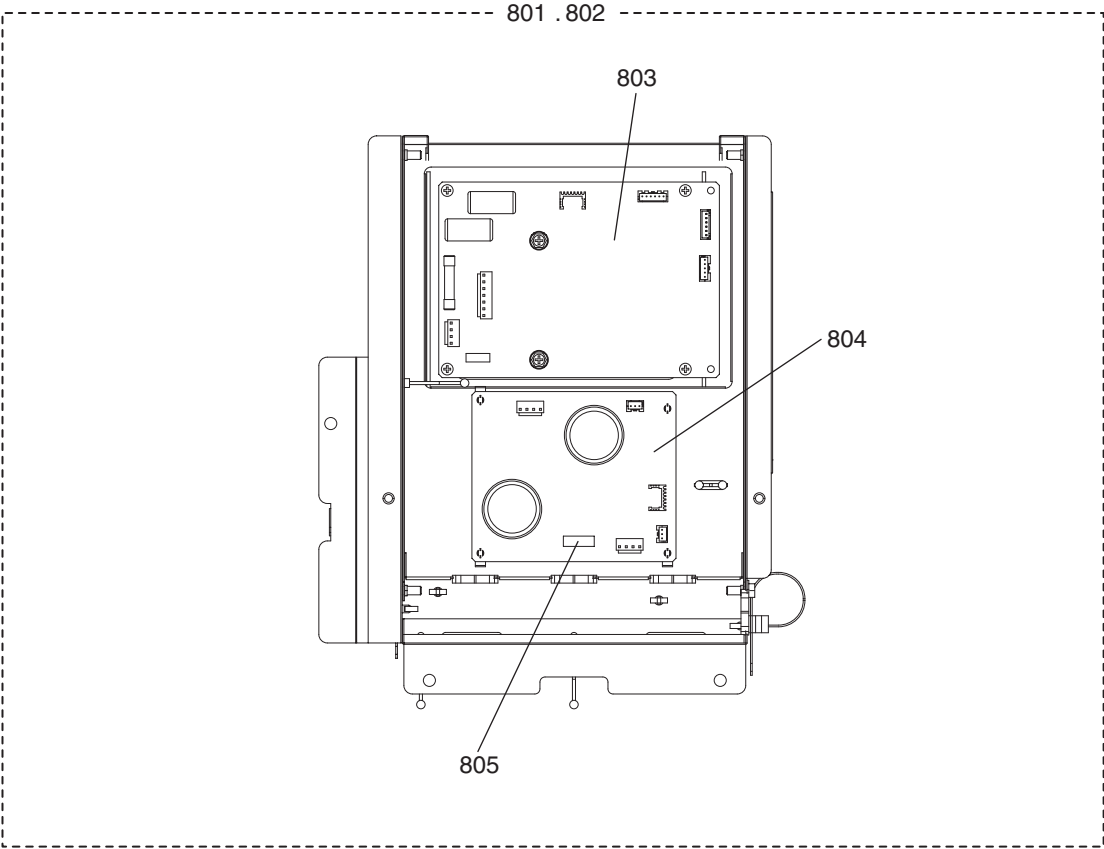

No.	Part No.	G : RoHS Apply Only W: RoHS Apply by Running Change		Spec.	PURY-P450YLM-A1	PURY-P450YLM-A1-BS	PURY-P500YLM-A1	PURY-P500YLM-A1-BS	Dwg. No.	Notes for the models	Revision info.
			Part Name								
801	R61 580 305	G	FAN box		1		1		KE80C721G11		
802	R61 581 305	G	FAN box			1		1	KE80C721G12		
803	R61 304 280	G	FAN board		1	1	1	1	W652171G18	<INV/S12Y>	
804	R63 194 280	G	Connect board		1	1	1	1	KE80C725G02	<CONNECT01>	
805	R12 001 964	G	Fuse		1	1	1	1	S423001H40		

mitsubishi
electric
corporation

BWE015010 (20150228)