

# SERVICE PARTS LIST FOR MITSUBISHI ELECTRIC PACKAGED AIR-CONDITIONERS

Series : PQHY-P•YLM-A

Dec. 2015  
BWE015290

INDEX
PQHY-P200YLM-A
PQHY-P250YLM-A
PQHY-P300YLM-A
PQHY-P350YLM-A
PQHY-P400YLM-A
PQHY-P450YLM-A
PQHY-P500YLM-A
PQHY-P550YLM-A
PQHY-P600YLM-A

## The Package name list

**PQHY-P400YSLM-A** [PQHY-P200YLM-A+PQHY-P200YLM-A]

**PQHY-P450YSLM-A** [PQHY-P200YLM-A+PQHY-P250YLM-A]

**PQHY-P500YSLM-A** [PQHY-P250YLM-A+PQHY-P250YLM-A]

**PQHY-P550YSLM-A** [PQHY-P250YLM-A+PQHY-P300YLM-A]

**PQHY-P600YSLM-A** [PQHY-P300YLM-A+PQHY-P300YLM-A]

**PQHY-P700YSLM-A** [PQHY-P350YLM-A+PQHY-P350YLM-A]

**PQHY-P750YSLM-A** [PQHY-P350YLM-A+PQHY-P400YLM-A]

**PQHY-P800YSLM-A** [PQHY-P400YLM-A+PQHY-P400YLM-A]

**PQHY-P850YSLM-A** [PQHY-P400YLM-A+PQHY-P450YLM-A]

**PQHY-P900YSLM-A** [PQHY-P450YLM-A+PQHY-P450YLM-A]

PQHY-P200YLM-A  
PQHY-P250YLM-A  
PQHY-P300YLM-A

### EXTERNAL PARTS (1)

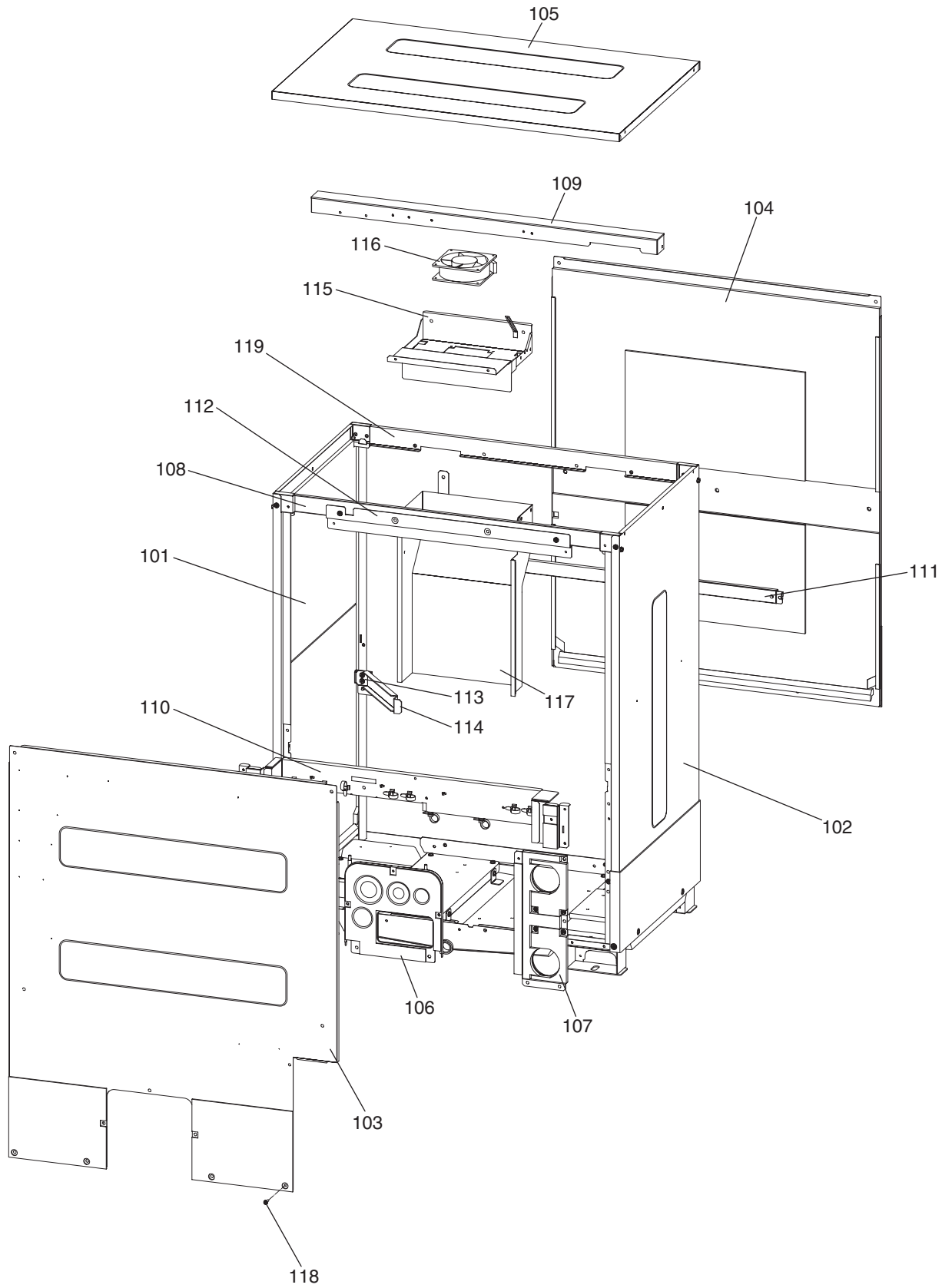

No.	Part No.	G : RoHS Apply Only W: RoHS Apply by Running Change	Part Name	Spec.	PQHY-P200YLM-A	PQHY-P250YLM-A	PQHY-P300YLM-A			Dwg. No.	Notes for the models	Revision info.
101	R63 140 662	G	Panel assy L		1	1	1			KJ00G340G04		
102	R63 141 662	G	Panel assy R		1	1	1			KJ00G342G04		
103	R61 168 662	G	Panel assy F		1	1	1			KS00C187G01		
104	R61 143 662	G	Panel assy B		1	1	1			KJ00G374G02		
105	R61 144 662	G	Panel T		1	1	1			KJ02G221H02		
106	R61 195 690	G	Piping cover		1	1	1			KD00M400G02		
107	R61 145 662	G	Panel assy W		1	1	1			KD00M376G01		
108	R61 101 162	G	Frame FU		1	1	1			KJ02G377H01		
109	R63 102 162	G	Frame assy U		1	1	1			KD00M398G02		
110	R61 119 162	G	Frame assy M		1	1	1			KD00U811G01		
111	R61 104 162	G	Frame assy MB		1	1	1			KD00M399G01		
112	R61 016 131	G	Attachment	Control box	1	1	1			KJ02T730H01		
113	R61 017 131	G	Attachment		1	1	1			KJ02D117H01		
114	R61 015 663	G	Plate OS		1	1	1			KJ02T637H01		
115	R61 040 128	G	Attachment fan		1	1	1			KS00C208G01		
116	R63 Y02 300	G	Fan	109S025UL	1	1	1			P712360X01		
117	R61 044 457	G	Duct		1	1	1			KS00C207G01		
118	R63 007 087	G	H Screw	5 x 10 KNURLED (30pcs)	3	3	3			KB00H418G14		
119	R63 123 162	G	Frame FR		1	1	1			KJ00D387G01		

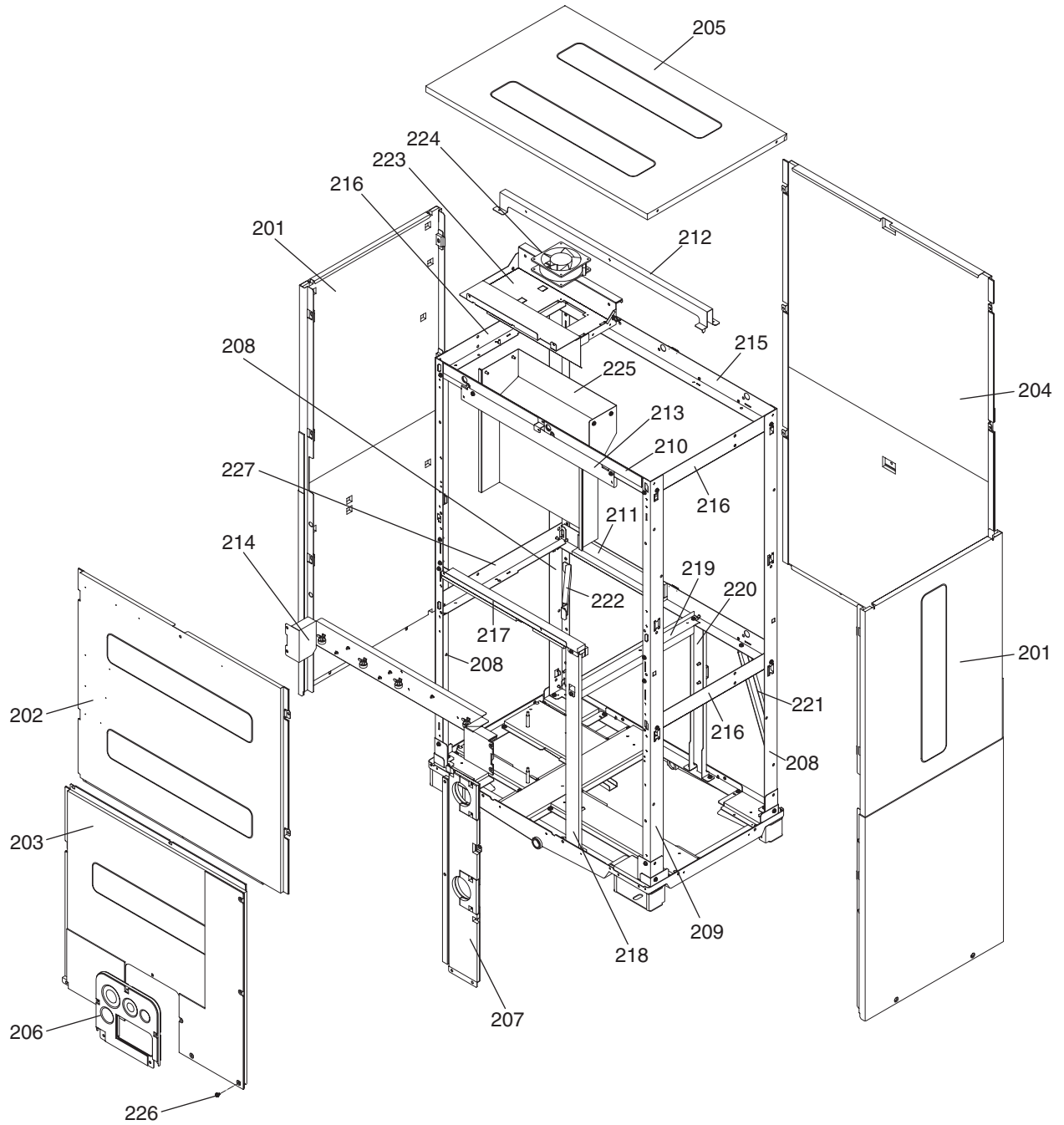

No.	Part No.	G : RoHS Apply Only W : RoHS Apply by Running Change		Spec.	PQHY-P350YLM-A	PQHY-P400YLM-A	PQHY-P450YLM-A	PQHY-P500YLM-A	PQHY-P550YLM-A	PQHY-P600YLM-A	Dwg. No.	Notes for the models	Revision info.
		Part Name											
201	R61 278 651	G	Panel assy LR		2	2	2	2	2	2	KJ00T103G02		
202	R61 290 651	G	Panel assy FU		1	1	1	1	1	1	KJ00T101G01		
203	R61 291 651	G	Panel assy FB		1	1	1	1	1	1	KJ00T102G01		
204	R61 292 651	G	Panel assy B		1	1	1	1	1	1	KJ00T104G03		
205	R61 293 651	G	Panel assy T		1	1	1	1	1	1	KJ00T613G01		
206	R61 195 690	G	Piping cover		1	1	1	1	1	1	KD00M400G02		
207	R63 294 651	G	Panel assy W		1	1	1	1	1	1	KB00M867G17		
208	R61 036 626	G	Pillar	Main	3	3	3	3	3	3	KB02V753H02		
209	R61 037 626	G	Pillar assy	Main	1	1	1	1	1	1	KJ00T627G02		
210	R61 111 162	G	Frame assy HF		1	1	1	1	1	1	KD00U723G01		
211	R61 112 162	G	Frame assy HB		1	1	1	1	1	1	KD00U724G01		
212	R61 113 162	G	Frame	Duct support	1	1	1	1	1	1	KJ02R943H01		
213	R61 015 131	G	Attachment	Control box	1	1	1	1	1	1	KJ02R945H01		
214	R61 114 162	G	Frame assy M		1	1	1	1	1	1	KD00U680G02		
215	R61 115 162	G	Frame assy H		1	1	1	1	1	1	KJ00T520G01		
216	R61 116 162	G	Frame side		3	3	3	3	3	3	KJ02R938H01		
217	R61 120 162	G	Frame assy HF		1	1	1	1	1	1	KJ00T628G02		
218	R61 038 626	G	Pillar	HEX support F	1	1	1	1	1	1	KJ02R940H01		
219	R61 121 162	G	Frame	HEX base	1	1	1	1	1	1	KD00U917G01		
220	R61 039 626	G	Pillar assy	HEX support	1	1	1	1	1	1	KD00U716G01		
221	R61 064 668	G	Frame support		1	1	1	1	1	1	KJ02T626H01		
222	R61 015 663	G	Plate OS		1	1	1	1	1	1	KJ02T637H01		
223	R61 039 128	G	Attachment fan		1	1	1	1	1	1	KJ00R960G01		
224	R63 Y02 300	G	Fan	109S025UL	1	1	1	1	1	1	P712360X01		
225	R61 043 457	G	Duct		1	1	1	1	1	1	KD00U645G01		
226	R63 007 087	G	H Screw	5 x 10 KNURLED (30pcs)	3	3	3	3	3	3	KB00H418G14		
227	R61 122 162	G	Frame side		1	1	1	1	1	1	KD00U927G01		



No.	Part No.	G : RoHS Apply Only W : RoHS Apply by Running Change		Spec.	PQHY-P200YLM-A	PQHY-P250YLM-A	PQHY-P300YLM-A	Dwg. No.	Notes for the models	Revision info.
		Part Name								
301	R69 103 478	G	Scroll compressor	ENB62FB-YE	1	1	1	EP10132B04		
302	R63 127 484	G	Accumulator assy		1	1	1	KB00M867G24		
303	R61 048 487	G	Oil separator assy		1	1	1	KJ00T811G01		
304	R61 A44 480	G	Heat exchanger assy	Water-side	1	1	1	KJ00T837G02		
305	R61 928 480	G	INV heat exchanger assy		1	1	1	KJ00T636G01		
306	R63 007 538	G	Valve	VSAMH8SSCM-LA1	1	1	1	P636353X01	<BV1>	
307	R61 009 538	G	Valve	VSAMH3SSCM-A	1	1	1	P636357X01	<BV2>	
308	R61 008 454	G	Strainer	25.4D	1	1	1	KB48K250G01	<ST1>	
309	R63 Y03 454	G	Strainer	17.6D	1	1	1	W893281G01	<ST2>	
310	R63 S84 413	G	Check joint		2	2	2	P666002X01	<CJ1,CJ2>	
311	R63 002 425	G	Capillary tube assy		1	1	1	KB49F229G01	<CP1>	
312	R61 005 418	G	Check valve	YAV-P11Y5HMD-1	1	1	1	P633133X01	<CV1>	
313	R63 046 232	G	Solenoid valve	FD2A77	1	1	1	P631312X01	<SV1a>	
314	R61 013 403	G	Four way valve	STF-H0731	1	1	1	P633130X01	<21S4a>	
315	R61 038 232	G	Solenoid valve block		1	1	1	KB00T028G03		
316	R63 001 921	G	Solenoid valve	VPV-603DQ3	1	1	1	P631295X01	<SV7a>	
317	R61 040 232	G	Solenoid valve	VPV-803DQ50	1	1	1	P631300X01	<SV7b>	
318	R63 032 243	G	Solenoid valve coil	FQ-G625	1	1	1	P472070X01	<SV1a>	
319	R61 009 242	G	Solenoid valve coil	STF-H01AJ1737A1	1	1	1	P472092X01	<21S4a>	
320	R63 Y18 243	G	Solenoid valve coil	A22-1B02B-1	3	3	3	P472012X01	<SV4a,SV4b,SV4d>	
321	R61 015 243	G	Solenoid valve coil	VPV-MOAJ512B1	2	2	2	P472048X01	<SV7a,SV7b>	
322	R63 R34 401	G	Linear expansion valve	CAM-B35YGMD-2	2	2	2	P632416X01	<LEV1,LEVINV>	
323	R61 036 401	G	Linear expansion valve	PAM-BBOYGMD-1	2	2	2	P632504X01	<LEV6,LEV7>	
324	R63 011 401	G	Linear expansion valve coil	CAM-MD12MD-123	1	1	1	P472059X02	<LEV1>	
325	R61 024 401	G	Linear expansion valve coil	CAM-MD12MD-116	1	1	1	P472054X02	<LEVINV>	
326	R61 022 243	G	Linear expansion valve coil	PAM-MD12MD-3	1	1	1	P472061X02	<LEV6>	
327	R61 093 401	G	Linear expansion valve coil	PAM-MD12MD-9	1	1	1	P472091X01	<LEV7>	
328	R63 018 208	G	Pressure switch	ACB-1UB28W	1	1	1	P426320X02	<63H1>	
329	R63 059 288	G	Pressure sensor	HP D173	1	1	1	KB00M867G10	<63HS1>	
330	R63 058 288	G	Pressure sensor	LP D173	1	1	1	KB00M867G11	<63LS>	
331	R61 060 200	G	Thermistor	150-522-96001	7	7	7	P418065X01	<TH2,TH3,TH5,TH6,TH7,TH8,THINV>	
332	R63 911 202	G	Thermistor	158-204-97484	1	1	1	P425416X02	<TH4>	



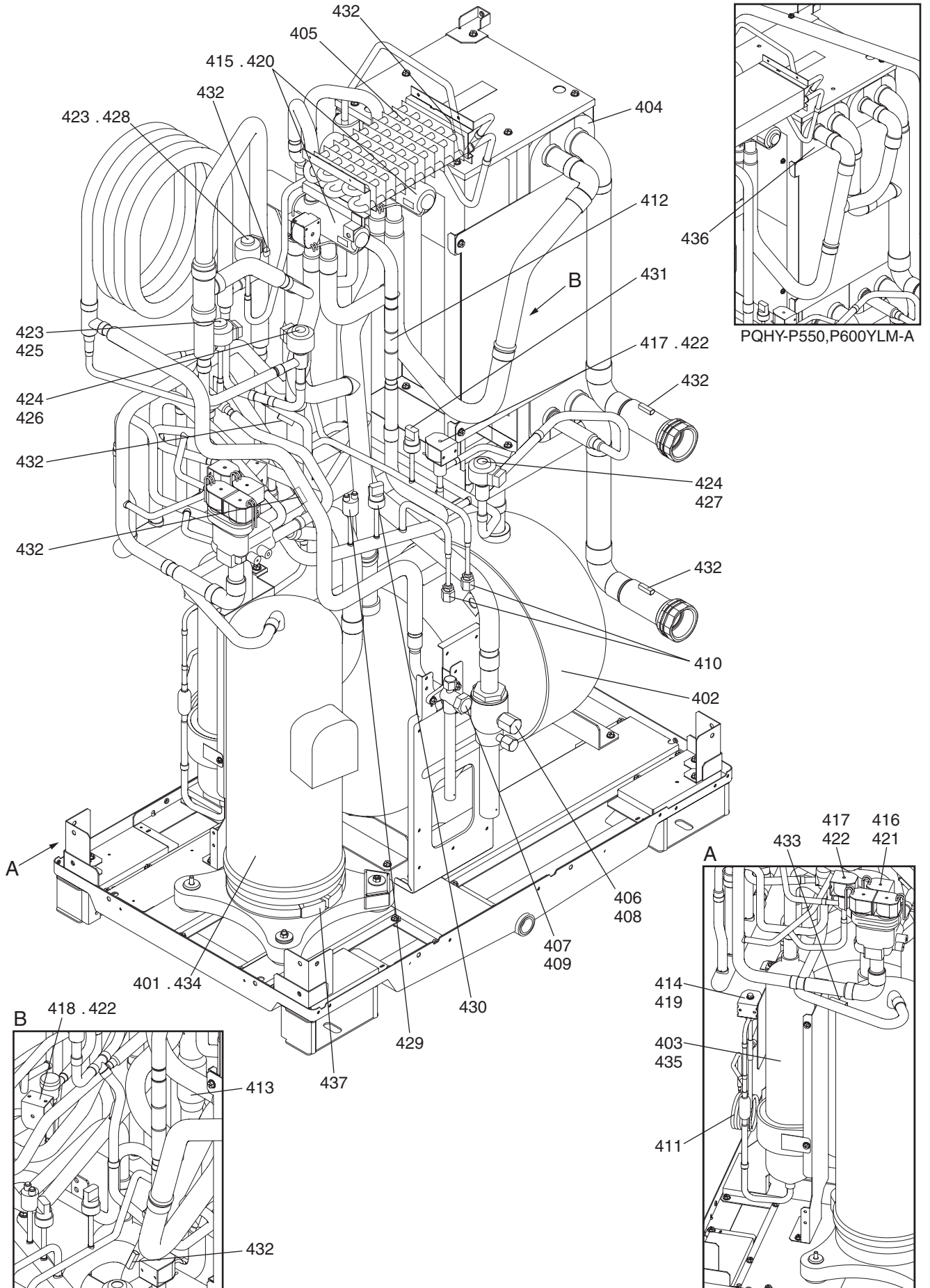

No.	Part No.	G : RoHS Apply Only W : RoHS Apply by Running Change	Part Name	Spec.	PQHY-P350YLM-A	PQHY-P400YLM-A	PQHY-P450YLM-A	PQHY-P500YLM-A	PQHY-P550YLM-A	PQHY-P600YLM-A	Dwg. No.	Notes for the models	Revision info.
401	R69 118 478	G	Scroll compressor	HNB84FC-YE	1	1	1	1			EP10126B04		
402	R61 128 484	G	Accumulator assy		1	1	1	1	1	1	KB00M867G25		
403	R61 049 487	G	Oil separator assy		1	1	1	1			KJ00T015G05		
404	R61 A47 480	G	Heat exchanger assy	Water-side	1	1	1	1			KB00M867G26		
405	R61 928 480	G	INV heat exchanger assy		1	1	1	1	1	1	KJ00T636G01		
406	R61 009 410	G	Ball valve	SBV-JA10YGME-3	1	1	1	1	1	1	P636358X01	<BV1>	
407	R63 014 538	G	Valve	FSV-JA5GME-19	1	1	1	1	1	1	P636362X02	<BV2>	
408	R61 008 454	G	Strainer	25.4D	1	1	1	1	1	1	KB48K250G01	<ST1>	
409	R63 Y03 454	G	Strainer	17.6D	1	1	1	1	1	1	W893281G01	<ST2>	
410	R63 S84 413	G	Check joint		2	2	2	2	2	2	P666002X01	<CJ1,CJ2>	
411	R61 027 425	G	Capillary tube assy		1	1	1	1	1	1	KD49U675G01	<CP1>	
412	R61 005 418	G	Check valve	YAV-P11Y5HMD-1	1	1	1	1	1	1	P633133X01	<CV1>	
413	R61 002 418	G	Check valve	YBV-22Y9GMD-1	1	1	1	1	1	1	P639183X01	<CV2>	
414	R63 046 232	G	Solenoid valve	FDFA277	1	1	1	1	1	1	P631312X01	<SV1a>	
415	R61 013 403	G	Four way valve	STF-H0731	2	2	2	2	2	2	P633130X01	<21S4a,21S4b>	
416	R61 038 232	G	Solenoid valve block		1	1	1	1	1	1	KB00T028G03		
417	R63 001 921	G	Solenoid valve	VPV-603DQ3	2	2	2	2	2	2	P631295X01	<SV7a,SV7c>	
418	R61 040 232	G	Solenoid valve	VPV-803DQ50	1	1	1	1	1	1	P631300X01	<SV7b>	
419	R63 032 243	G	Solenoid valve coil	FQ-G625	1	1	1	1	1	1	P472070X01	<SV1a>	
420	R61 009 242	G	Solenoid valve coil	STF-H01AJ1737A1	2	2	2	2	2	2	P472092X01	<21S4a,21S4b>	
421	R63 Y18 243	G	Solenoid valve coil	A22-1B02B-1	3	3	3	3	3	3	P472012X01	<SV4a,SV4b,SV4d>	
422	R61 015 243	G	Solenoid valve coil	VPV-MOAJ512B1	3	3	3	3	3	3	P472048X01	<SV7a,SV7b,SV7c>	
423	R63 R34 401	G	Linear expansion valve	CAM-B35YGMD-2	2	2	2	2	2	2	P632416X01	<LEV1,LEVINV>	
424	R61 036 401	G	Linear expansion valve	PAM-BBOYGMD-1	2	2	2	2	2	2	P632504X01	<LEV6,LEV7>	
425	R63 011 401	G	Linear expansion valve coil	CAM-MD12MD-123	1	1	1	1	1	1	P472059X02	<LEV1>	
426	R61 022 243	G	Linear expansion valve coil	PAM-MD12MD-3	1	1	1	1	1	1	P472061X02	<LEV6>	
427	R61 093 401	G	Linear expansion valve coil	PAM-MD12MD-9	1	1	1	1	1	1	P472091X01	<LEV7>	
428	R61 094 401	G	Linear expansion valve coil	CAM-MD12MD-124	1	1	1	1	1	1	P472097X01	<LEVINV>	
429	R63 018 208	G	Pressure switch	ACB-1UB28W	1	1	1	1	1	1	P426320X02	<63H1>	
430	R63 067 288	G	Pressure sensor	HP D173	1	1	1	1	1	1	KB00M867G13	<63HS1>	
431	R63 068 288	G	Pressure sensor	LP D173	1	1	1	1	1	1	KB00M867G14	<63LS>	
432	R61 060 200	G	Thermistor	150-522-96001	7	7	7	7	7	7	P418065X01	<TH2,TH3,TH5,TH6,TH7,TH8,THINV>	
433	R63 911 202	G	Thermistor	158-204-97484	1	1	1	1	1	1	P425416X02	<TH4>	
434	R69 133 478	G	Scroll compressor	HNB97FA-YE							EP10148B01		
435	R61 050 487	G	Oil separator assy								KJ00T015G04		
436	R61 A02 480	G	Heat exchanger assy	Water-side							KB00M867G21		
437	R63 Y07 237	G	Belt heater	SP4689F-04V							P493781X02	<CH11>	

PQHY-P200,P250,P300YLM-A  
PQHY-P350,P400,P450YLM-A  
PQHY-P500,P550,P600YLM-A

# CONTROL BOX PARTS

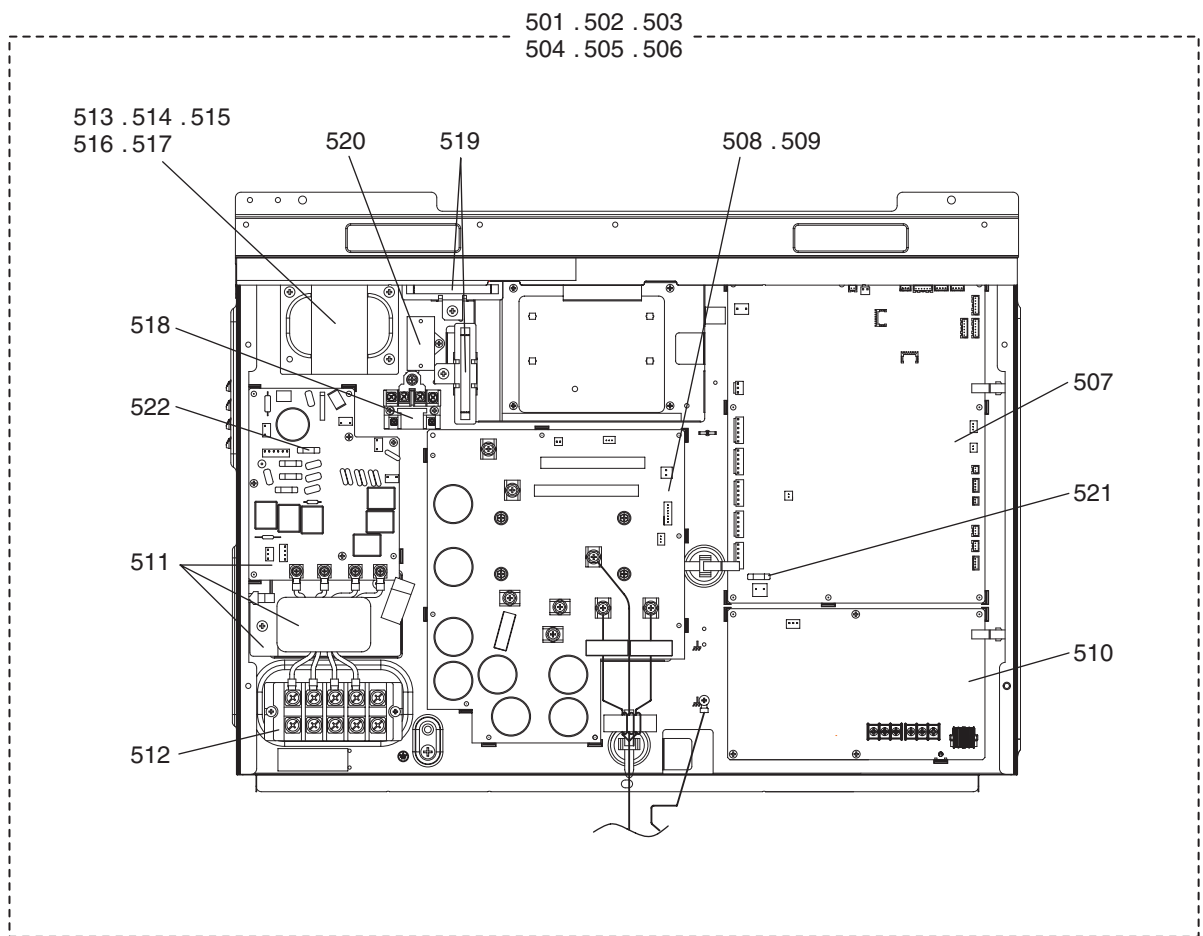

**PQHY-P200,P250,P300YLM-A  
PQHY-P350,P400,P450YLM-A  
PQHY-P500,P550,P600YLM-A**

**CONTROL BOX PARTS**

No.	Part No.	G : RoHS Apply Only W : RoHS Apply by Running Change	Part Name	Spec.	PQHY-P200YLM-A	PQHY-P250YLM-A	PQHY-P300YLM-A	PQHY-P350YLM-A	PQHY-P400YLM-A	PQHY-P450YLM-A	Dwg. No.	Notes for the models	Revision info.
501	R61 754 305	G	Control box	WY-P200YLM	1						KE80G095GA3		
502	R61 755 305	G	Control box	WY-P250YLM		1					KE80G095GA4		
503	R61 756 305	G	Control box	WY-P300YLM			1				KE80G095GA5		
504	R61 757 305	G	Control box	WY-P350YLM				1			KE80G095GA6		
505	R61 758 305	G	Control box	WY-P400/450/500YLM					1	1	KE80G095GA7		
506	R61 759 305	G	Control box	WY-P550/600YLM							KE80G095GA8		
507	R63 340 280	G	Control board		1	1	1	1	1	1	KE80C836G12	<MAIN09>	
508	R61 401 280	G	INV board		1	1	1				KE80C154G28	<INV20Y>	
509	R61 402 280	G	INV board					1	1	1	KE80C154G29	<INV20Y>	
510	R63 278 280	G	M-NET board		1	1	1	1	1	1	KE80C055G07	<PS-MNET-Y>	
511	R61 028 293	G	Noise filter	board,coil,plate	1	1	1	1	1	1	KE80C727G03		
512	R61 007 246	G	Terminal block		1	1	1	1	1	1	S436005H12	<TB1>	
513	R61 023 259	G	Reactor		1						P715466X01	<DCL>	
514	R61 017 259	G	Reactor			1					P715458X01	<DCL>	
515	R61 027 259	G	Reactor				1	1			P715476X02	<DCL>	
516	R61 028 259	G	Reactor						1	1	P715475X02	<DCL>	
517	R61 012 259	G	Reactor								P715441X02	<DCL>	
518	R61 003 216	G	Relay		1	1	1	1	1	1	P421295X01	<72C>	
519	R61 001 234	G	Resistor		2	2	2	2	2	2	P411151X01	<R1,R5>	
520	R61 001 255	G	Capacitor assy		1	1	1	1	1	1	KE00D263G01	<C100>	
521	R61 018 239	G	Fuse	3.15A AC250V T	1	1	1	1	1	1	YE81D827H02		
522	R61 006 239	G	Fuse	6.3A AC250V T	1	1	1	1	1	1	S423001H42		

PQHY-P200,P250,P300YLM-A  
PQHY-P350,P400,P450YLM-A  
PQHY-P500,P550,P600YLM-A

### CONTROL BOX PARTS

No.	Part No.	G : RoHS Apply Only W : RoHS Apply by Running Change		Spec.	PQHY-P500YLM-A	PQHY-P550YLM-A	PQHY-P600YLM-A			Dwg. No.	Notes for the models	Revision info.
		Part Name										
501	R61 754 305	G	Control box	WY-P200YLM						KE80G095GA3		
502	R61 755 305	G	Control box	WY-P250YLM						KE80G095GA4		
503	R61 756 305	G	Control box	WY-P300YLM						KE80G095GA5		
504	R61 757 305	G	Control box	WY-P350YLM						KE80G095GA6		
505	R61 758 305	G	Control box	WY-P400/450/500YLM	1					KE80G095GA7		
506	R61 759 305	G	Control box	WY-P550/600YLM		1	1			KE80G095GA8		
507	R63 340 280	G	Control board		1	1	1			KE80C836G12	<MAIN09>	
508	R61 401 280	G	INV board							KE80C154G28	<INV20Y>	
509	R61 402 280	G	INV board		1	1	1			KE80C154G29	<INV20Y>	
510	R63 278 280	G	M-NET board		1	1	1			KE80C055G07	<PS-MNET-Y>	
511	R61 028 293	G	Noise filter	board,coil,plate	1	1	1			KE80C727G03		
512	R61 007 246	G	Terminal block		1	1	1			S436005H12	<TB1>	
513	R61 023 259	G	Reactor							P715466X01	<DCL>	
514	R61 017 259	G	Reactor							P715458X01	<DCL>	
515	R61 027 259	G	Reactor							P715476X02	<DCL>	
516	R61 028 259	G	Reactor		1					P715475X02	<DCL>	
517	R61 012 259	G	Reactor			1	1			P715441X02	<DCL>	
518	R61 003 216	G	Relay		1	1	1			P421295X01	<72C>	
519	R61 001 234	G	Resistor		2	2	2			P411151X01	<R1,R5>	
520	R61 001 255	G	Capacitor assy		1	1	1			KE00D263G01	<C100>	
521	R61 018 239	G	Fuse	3.15A AC250V T	1	1	1			YE81D827H02		
522	R61 006 239	G	Fuse	6.3A AC250V T	1	1	1			S423001H42		

PQHY-P200,P250,P300YLM-A  
PQHY-P350,P400,P450YLM-A  
PQHY-P500,P550,P600YLM-A

### I/O BOX PARTS

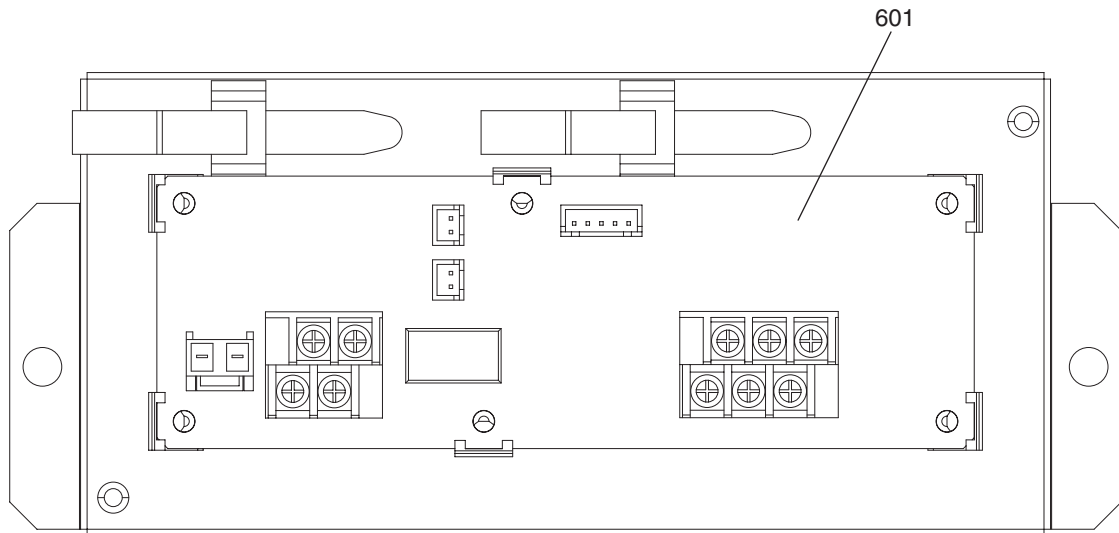







**mitsubishi**  
**electric**  
**corporation**

---

BWE015290 (20151231)