

TECHNICAL & SERVICE MANUAL

Series PLFY Ceiling Cassettes R410A

Indoor unit
[Model names]

PLFY-P20VEM-E
 PLFY-P25VEM-E
 PLFY-P32VEM-E
 PLFY-P40VEM-E
 PLFY-P50VEM-E
 PLFY-P63VEM-E
 PLFY-P80VEM-E
 PLFY-P100VEM-E
 PLFY-P125VEM-E

[Service Ref.]

PLFY-P20VEM-E.UK
 PLFY-P25VEM-E.UK
 PLFY-P32VEM-E.UK
 PLFY-P40VEM-E.UK
 PLFY-P50VEM-E.UK
 PLFY-P63VEM-E.UK
 PLFY-P80VEM-E.UK
 PLFY-P100VEM-E.UK
 PLFY-P125VEM-E.UK

Notes:

- This manual describes service data of the indoor units only.
- RoHS compliant products have <G> mark on the spec name plate.

Grille model
[Model names]

PLP-6EA
 PLP-6EAE
 PLP-6EAL
 PLP-6EAL
 PLP-6EAL
 PLP-6EAL
 PLP-6EAL
 PLP-6EAL
 PLP-6EAL
 PLP-6EAL

[Service Ref.]

PLP-6EA
 PLP-6EAE
 PLP-6EAL
 PLP-6EAL
 PLP-6EAL
 PLP-6EAL
 PLP-6EAL
 PLP-6EAL
 PLP-6EAL
 PLP-6EAL

PLP-6EAR1
 PLP-6EAER1
 PLP-6EALR1
 PLP-6EALER1

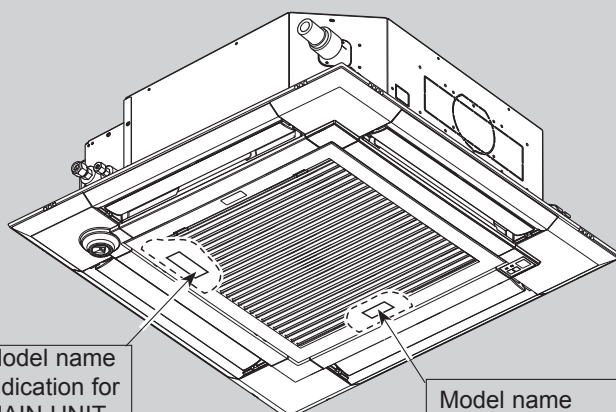
INDOOR UNIT

 Model name
indication for
MAIN UNIT

 Model name
indication for GRILLE

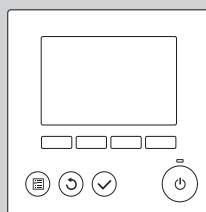
**WIRELESS REMOTE
CONTROLLER
(Option)**

**WIRED REMOTE
CONTROLLER
(Option)**

CONTENTS

1. SAFETY PRECAUTION.....	2
2. PARTS NAMES AND FUNCTIONS.....	4
3. SPECIFICATIONS.....	11
4. 4-WAY AIR FLOW SYSTEM.....	16
5. OUTLINES AND DIMENSIONS.....	19
6. WIRING DIAGRAM.....	20
7. REFRIGERANT SYSTEM DIAGRAM.....	21
8. TROUBLESHOOTING.....	22
9. SPECIAL FUNCTION.....	30
10. DISASSEMBLY PROCEDURE.....	33

PARTS CATALOG (OCB657)

CITY MULTI

Cautions for units utilizing refrigerant R410A

Do not use the existing refrigerant piping.

The old refrigerant and lubricant in the existing piping contain a large amount of chlorine which may cause the lubricant deterioration of the new unit.

Use "low residual oil piping"

If there is a large amount of residual oil (hydraulic oil, etc.) inside the piping and joints, deterioration of the lubricant will result.

Store the piping indoors, and both ends of the piping sealed until just before brazing. (Leave elbow joints, etc. in their packaging.)

If dirt, dust or moisture enters into refrigerant cycle, that can cause deterioration of refrigerant oil or malfunction of compressor.

The refrigerant oil applied to flare and flange connections must be ester oil, ether oil or alkylbenzene oil in a small amount.

If large amount of mineral oil enters, that can cause deterioration of refrigerant oil, etc.

Charge refrigerant from liquid phase of gas cylinder.

If the refrigerant is charged from gas phase, composition change may occur in refrigerant and the efficiency will be lowered.

Do not use refrigerant other than R410A.

If other refrigerant (R22, etc.) is used, chlorine in refrigerant can cause deterioration of refrigerant oil etc.

Use a vacuum pump with a reverse flow check valve.

Vacuum pump oil may flow back into refrigerant cycle and that can cause deterioration of refrigerant oil etc.

Use the following tools specifically designed for use with R410A refrigerant.

The following tools are necessary to use R410A refrigerant.

Tools for R410A	
Gauge manifold	Flare tool
Charge hose	Size adjustment gauge
Gas leak detector	Vacuum pump adaptor
Torque wrench	Electronic refrigerant charging scale

Handle tools with care.

If dirt, dust or moisture enters into refrigerant cycle, that can cause deterioration of refrigerant oil or malfunction of compressor.

Do not use a charging cylinder.

If a charging cylinder is used, the composition of refrigerant will change and the efficiency will be lowered.

Use the specified refrigerant only.**Never use any refrigerant other than that specified.**

Doing so may cause a burst, an explosion, or fire when the unit is being used, serviced, or disposed of.

Correct refrigerant is specified in the manuals and on the spec labels provided with our products.

We will not be held responsible for mechanical failure, system malfunction, unit breakdown or accidents caused by failure to follow the instructions.

Ventilate the room if refrigerant leaks during operation. If refrigerant comes into contact with a flame, poisonous gases will be released.

[1] Cautions for service

- (1) Perform service after recovering the refrigerant left in unit completely.
- (2) Do not release refrigerant in the air.
- (3) After completing service, charge the cycle with specified amount of refrigerant.
- (4) When performing service, install a filter drier simultaneously.
Be sure to use a filter drier for new refrigerant.

[2] Additional refrigerant charge

When charging directly from cylinder

- (1) Check that cylinder for R410A available on the market is syphon type.
- (2) Charging should be performed with the cylinder of syphon stood vertically. (Refrigerant is charged from liquid phase.)

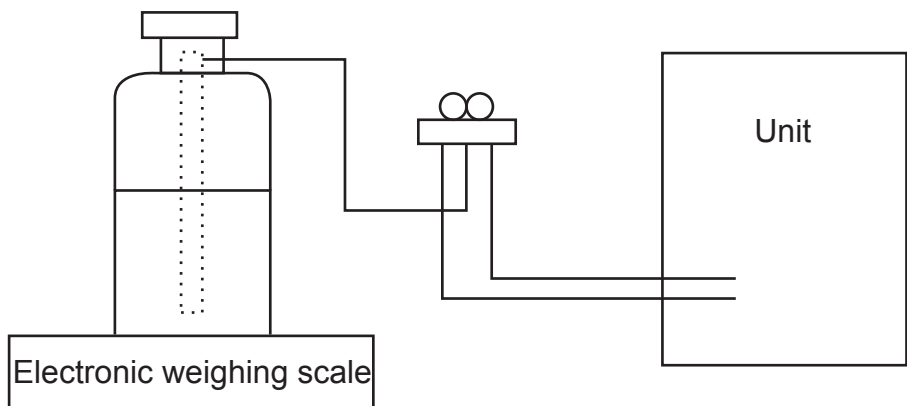

[3] Service tools

Use the below service tools as exclusive tools for R410A refrigerant.

No.	Tool name	Specifications
①	Gauge manifold	·Only for R410A
		·Use the existing fitting specifications. (UNF1/2)
		·Use high-tension side pressure of 5.3MPa·G or over.
②	Charge hose	·Only for R410A
		·Use pressure performance of 5.09MPa·G or over.
③	Electronic scale	—
④	Gas leak detector	·Use the detector for R134a, R407C or R410A.
⑤	Adaptor for reverse flow check	·Attach on vacuum pump.
⑥	Refrigerant charge base	—
⑦	Refrigerant cylinder	·Only for R410A ·Top of cylinder (Pink)
		·Cylinder with syphon
⑧	Refrigerant recovery equipment	—

2-1. Indoor unit

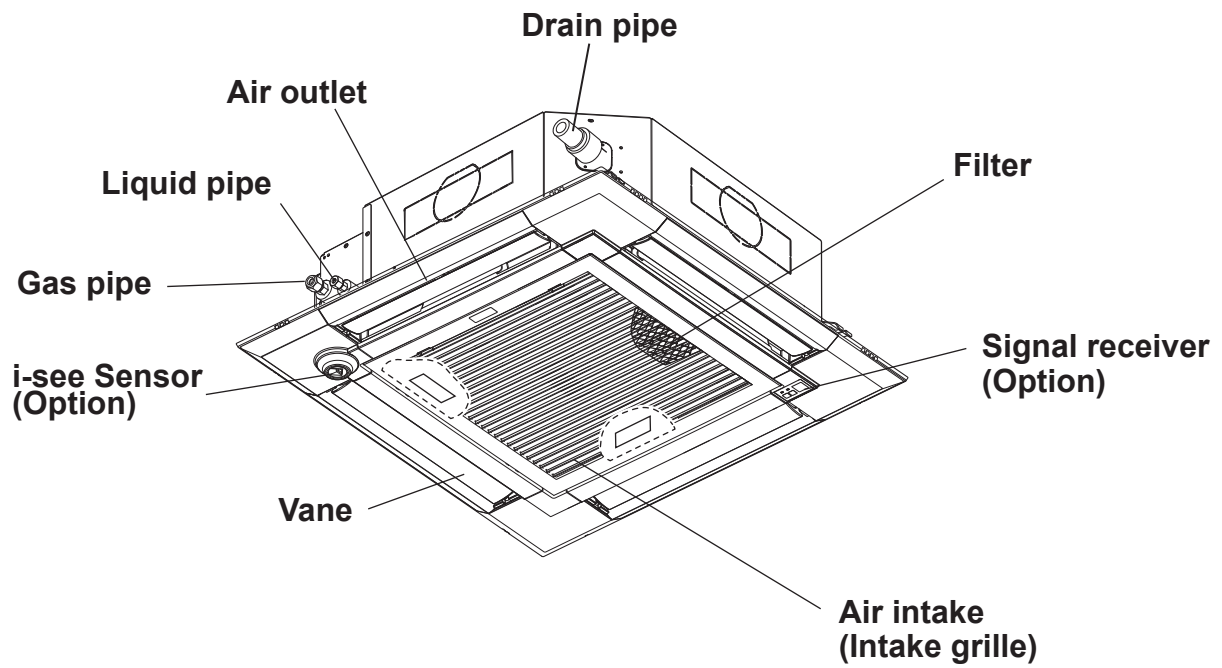

2-2. WIRED REMOTE CONTROLLER <PAR-32MAA>

Wired remote controller function

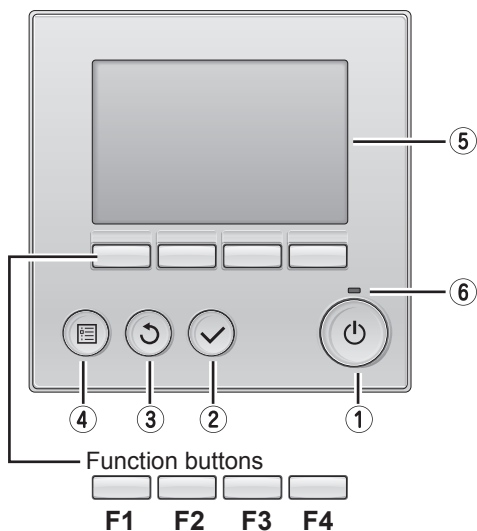

① ON/OFF button

Press to turn ON/OFF the indoor unit.

② SELECT button

Press to save the setting.

③ RETURN button

Press to return to the previous screen.

④ MENU button

Press to bring up the Main menu.

⑤ Backlit LCD

Operation settings will appear.
When the backlight is off, pressing any button turns the backlight on and it will stay lit for a certain period of time depending on the screen.

When the backlight is off, pressing any button turns the backlight on and does not perform its function. (except for the  (ON/OFF) button)

The functions of the function buttons change depending on the screen. Refer to the button function guide that appears at the bottom of the LCD for the functions they serve on a given screen.

When the system is centrally controlled, the button function guide that corresponds to the locked button will not appear.

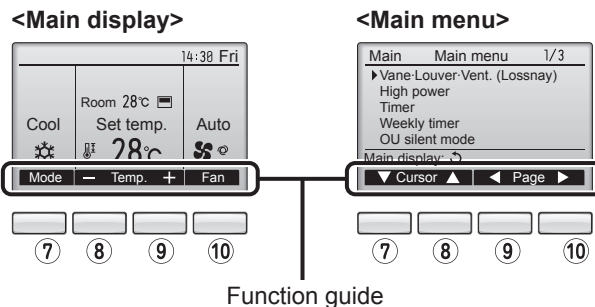

⑥ ON/OFF lamp

This lamp lights up in green while the unit is in operation. It blinks while the remote controller is starting up or when there is an error.

⑦ Function button **F1**

Main display : Press to change the operation mode.
Main menu : Press to move the cursor down.

⑧ Function button **F2**

Main display : Press to decrease temperature.
Main menu : Press to move the cursor up.

⑨ Function button **F3**

Main display : Press to increase temperature.
Main menu : Press to go to the previous page.

⑩ Function button **F4**

Main display : Press to change the fan speed.
Main menu : Press to go to the next page.

The main display can be displayed in 2 different modes: "Full" and "Basic".

The factory setting is "Full". To switch to the "Basic" mode, change the setting on the Main display setting.

<Full mode>

All icons are displayed for explanation.

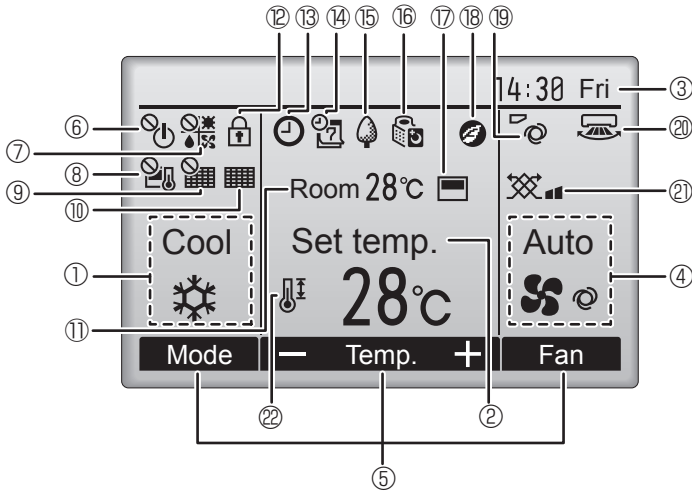

<Basic mode>

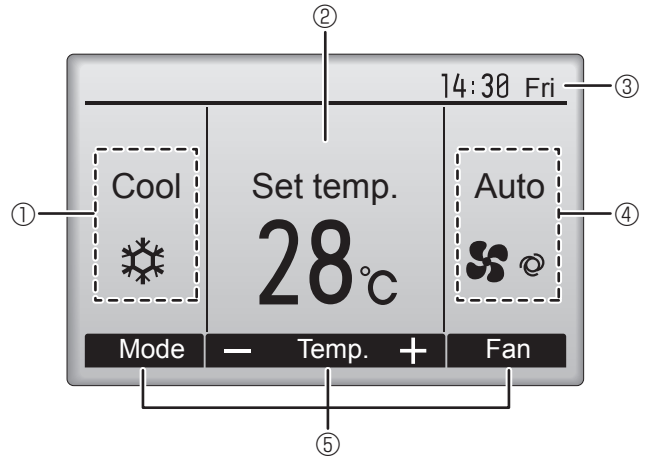

① Operation mode

Indoor unit operation mode appears here.

② Preset temperature

Preset temperature appears here.

③ Clock (See the Installation Manual.)

Current time appears here.

④ Fan speed

Fan speed setting appears here.

⑤ Button function guide

Functions of the corresponding buttons appear here.



Appears when the ON/OFF operation is centrally controlled.



Appears when the operation mode is centrally controlled.



Appears when the preset temperature is centrally controlled.



Appears when the filter reset function is centrally controlled.



Indicates when filter needs maintenance.

⑪ Room temperature (See the Installation Manual.)

Current room temperature appears here.



Appears when the buttons are locked.



Appears when the On/Off timer or Night setback function is enabled.



Appears when the Weekly timer is enabled.



Appears while the units are operated in the energy-save mode.



Appears while the outdoor units are operated in the silent mode.



Appears when the built-in thermistor on the remote controller is activated to monitor the room temperature.

appears when the thermistor on the indoor unit is activated to monitor the room temperature.



Appears when the units are operated in the energy-save mode with 3D i-see Sensor.



Indicates the vane setting.



Indicates the louver setting.



Indicates the ventilation setting.



Appears when the preset temperature range is restricted.

Most settings (except ON/OFF, mode, fan speed, temperature) can be made from the Menu screen.

Menu structure

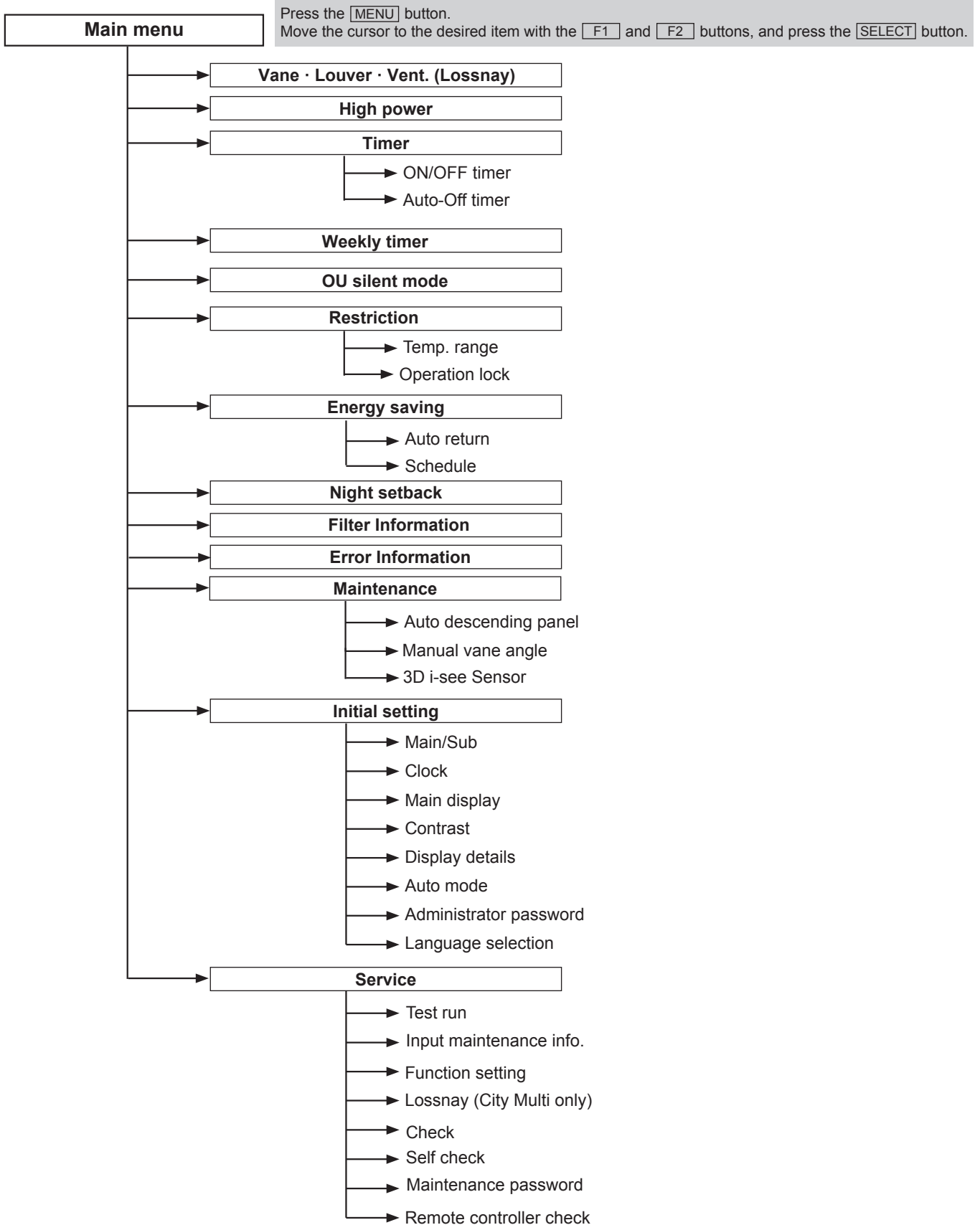

Not all functions are available on all models of indoor units.

Main menu list

Setting and display items		Setting details
Vane · Louver · Vent. (Lossnay)		<p>Use to set the vane angle.</p> <ul style="list-style-type: none"> • Select a desired vane setting from 5 different settings. <p>Use to turn ON/OFF the louver.</p> <ul style="list-style-type: none"> • Select a desired setting from "ON" and "OFF." <p>Use to set the amount of ventilation.</p> <ul style="list-style-type: none"> • Select a desired setting from "Off," "Low," and "High."
High power		<p>Use to reach the comfortable room temperature quickly.</p> <ul style="list-style-type: none"> • Units can be operated in the High-power mode for up to 30 minutes.
Timer	ON/OFF timer*	<p>Use to set the operation ON/OFF times.</p> <ul style="list-style-type: none"> • Time can be set in 5-minute increments.
	Auto-Off timer	<p>Use to set the Auto-Off time.</p> <ul style="list-style-type: none"> • Time can be set to a value from 30 to 240 in 10-minute increments.
Weekly timer*		<p>Use to set the weekly operation ON/OFF times.</p> <ul style="list-style-type: none"> • Up to 8 operation patterns can be set for each day. (Not valid when the ON/OFF timer is enabled.)
OU silent mode*		<p>Use to set the time periods in which priority is given to quiet operation of outdoor units over temperature control. Set the Start/Stop times for each day of the week.</p> <ul style="list-style-type: none"> • Select the desired silent level from "Normal", "Middle" and "Quiet".
Restriction	Temp. range	<p>Use to restrict the preset temperature range.</p> <ul style="list-style-type: none"> • Different temperature ranges can be set for different operation modes.
	Operation lock	<p>Use to lock selected functions.</p> <ul style="list-style-type: none"> • The locked functions cannot be operated.
Energy saving	Auto return	<p>Use to get the units to operate at the preset temperature after performing energy-save operation for a specified time period.</p> <ul style="list-style-type: none"> • Time can be set to a value from 30 and 120 in 10-minute increments. (This function will not be valid when the preset temperature ranges are restricted.)
	Schedule*	<p>Set the start/stop times to operate the units in the energy-save mode for each day of the week, and set the energy-saving rate.</p> <ul style="list-style-type: none"> • Up to 4 energy-save operation patterns can be set for each day. • Time can be set in 5-minute increments. • Energy-saving rate can be set to a value from 0% or 50 to 90% in 10% increments.
Night setback*		<p>Use to make Night setback settings.</p> <ul style="list-style-type: none"> • Select "Yes" to enable the setting, and "No" to disable the setting. The temperature range and the start/stop times can be set.
Filter information		<p>Use to check the filter status.</p> <ul style="list-style-type: none"> • The filter sign can be reset.
Error information		<p>Use to check error information when an error occurs.</p> <ul style="list-style-type: none"> • Check code, error source, refrigerant address, unit model, manufacturing number, contact information (dealer's phone number) can be displayed. (The unit model, manufacturing number, and contact information need to be registered in advance to be displayed.)
Maintenance	Auto descending panel	<p>Auto descending panel (Optional parts) UP/DOWN you can do.</p>
	Manual vane angle	<p>Use to set the vane angle for each vane to a fixed position.</p>
	3D i-see Sensor	<p>Use to set the following functions for 3D i-see Sensor.</p> <ul style="list-style-type: none"> • Air distribution • Energy saving option • Seasonal airflow

* Clock setting is required.

Continue to the next page

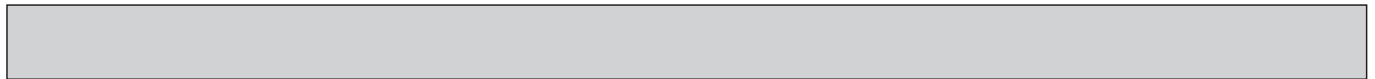

Setting and display items		Setting details
Initial setting	Main/Sub	When connecting 2 remote controllers, one of them needs to be designated as a sub controller.
	Clock	Use to set the current time.
	Main display	Use to switch between "Full" and "Basic" modes for the Main display. • The initial setting is "Full."
	Contrast	Use to adjust screen contrast.
	Display details	Make the settings for the remote controller related items as necessary. Clock: The initial settings are "Yes" and "24h" format. Temperature: Set either Celsius (°C) or Fahrenheit (°F). Room temp. : Set Show or Hide. Auto mode: Set the Auto mode display or Only Auto display.
	Auto mode	Whether or not to use the AUTO mode can be selected by using the button. This setting is valid only when indoor units with the AUTO mode function are connected.
	Administrator password	The administrator password is required to make the settings for the following items. • Timer setting • Energy-save setting • Weekly timer setting • Restriction setting • Outdoor unit silent mode setting • Night set back
	Language selection	Use to select the desired language.
Service	Test run	Select "Test run" from the Service menu to bring up the Test run menu. • Test run • Drain pump test run
	Input maintenance info.	Select "Input maintenance Info." from the Service menu to bring up the Maintenance information screen. The following settings can be made from the Maintenance Information screen. • Model name input • Serial No. input • Dealer information input
	Function setting (City Multi)	Make the settings for the indoor unit functions via the remote controller as necessary.
	LOSSNAY (City Multi only)	This setting is required only when the operation of City Multi units is interlocked with LOSSNAY units.
	Check	Error history: Display the error history and execute delete error history. Refrigerant leak check: Refrigerant leaks can be judged. Smooth maintenance: The indoor and outdoor maintenance data can be displayed. Request code: Details of the operation data including each thermistor temperature and error history can be checked.
	Self check	Error history of each unit can be checked via the remote controller.
	Maintenance password	Use to change the maintenance password.
	Remote controller check	When the remote controller does not work properly, use the remote controller checking function to troubleshoot the problem.

2-3. Wireless remote controller

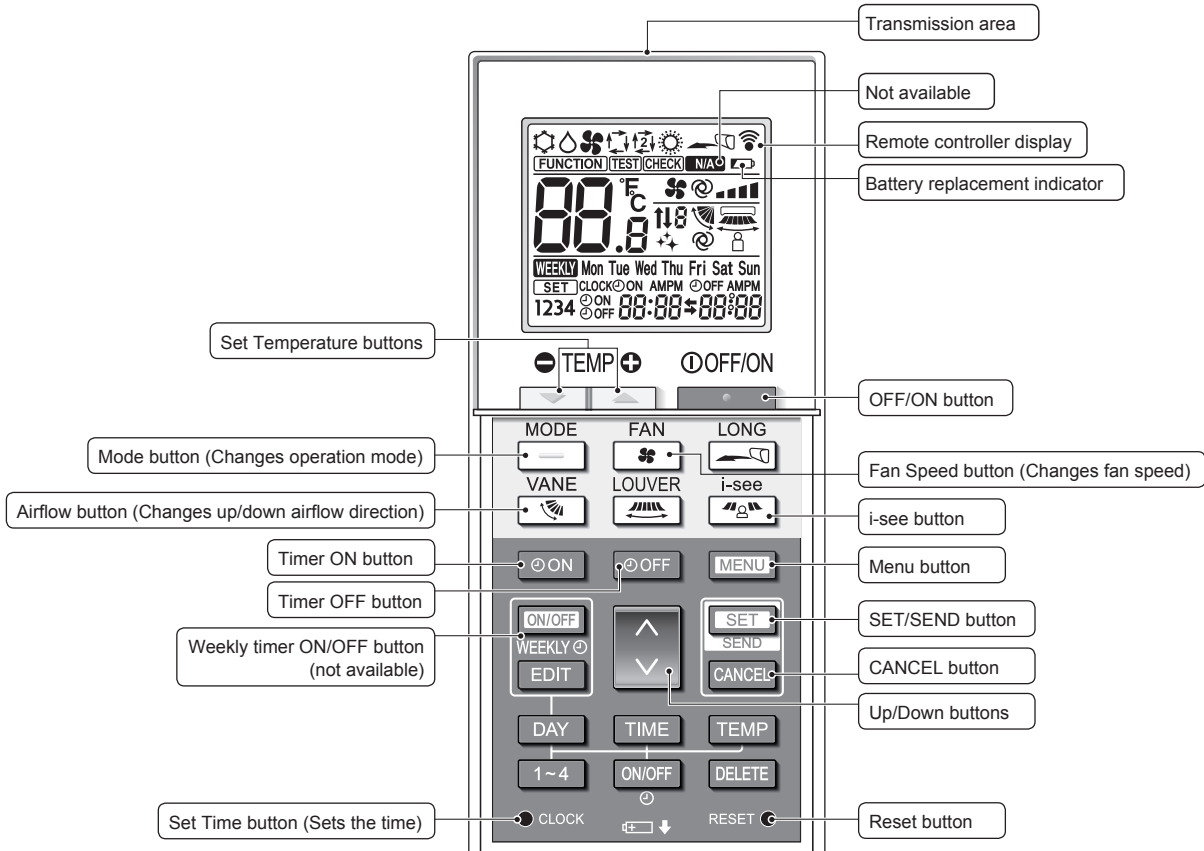

Operation mode

- | | |
|------|-------------------------|
| Cool | Dry |
| Fan | Auto (single set point) |
| Heat | Auto (dual set point*) |

* The initial setting is necessary. Refer to Installation manual.

Temperature setting

The units of temperature can be changed. For details, refer to the Installation Manual.

Vane setting

Step 1 Step 2 Step 3 Step 4 Step 5 Swing Auto

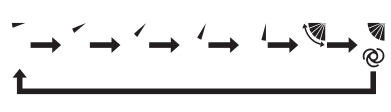

Not available

Appears when a non-supported function is selected.

Battery replacement indicator

Appears when the remaining battery power is low.

Fan speed setting

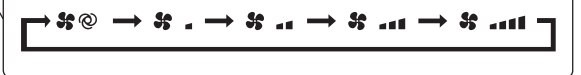

3D i-see Sensor (Air distribution)

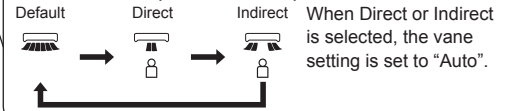

3-1. SPECIFICATIONS

Model		PLFY-P20VEM-E	PLFY-P25VEM-E	PLFY-P32VEM-E	PLFY-P40VEM-E	PLFY-P50VEM-E	PLFY-P63VEM-E		
Power source		1-phase 220-240V 50Hz, 1-phase 220V 60Hz							
Cooling capacity (Nominal)	*1 kW	2.2	2.8	3.6	4.5	5.6	7.1		
	*1 kcal/h	1,900	2,400	3,100	3,900	4,800	6,100		
	*1 BTU/h	7,500	9,600	12,300	15,400	19,100	24,200		
	*2 kcal/h	2,000	2,500	3,150	4,000	5,000	6,300		
	Power input	kW	0.03	0.03	0.03	0.03	0.03	0.03	
	Current input	A	0.31	0.32	0.32	0.32	0.36		
Heating capacity (Nominal)	*3 kW	2.5	3.2	4.0	5.0	6.3	8.0		
	*3 kcal/h	2,200	2,800	3,400	4,300	5,400	6,900		
	*3 BTU/h	8,500	10,900	13,600	17,100	21,500	27,300		
	Power input	kW	0.03	0.03	0.03	0.03	0.03	0.03	
	Current input	A	0.24	0.24	0.25	0.25	0.25	0.29	
External finish		Galvanized steel sheet							
External dimension H × W × D		mm 258 × 840 × 840 inch 10-3/16 × 33-3/32 × 33-3/32							
Net weight		kg (lb)	19 (42)	19 (42)	19 (42)	19 (42)	21 (46)		
Grille	model	PLP-6EA	PLP-6EA	PLP-6EA	PLP-6EA	PLP-6EA	PLP-6EA		
	External finish		MUNSELL (10Y 9.2/0.2)						
	Dimension H × W × D		mm 40 × 950 × 950 inch 1-9/16 × 37-13/32 × 37-13/32						
	Net weight		kg (lb) 5 (11)						
	Heat exchanger		Cross fin (Aluminum fin and copper tube)						
FAN			Turbo fan × 1	Turbo fan × 1	Turbo fan × 1	Turbo fan × 1	Turbo fan × 1	Turbo fan × 1	
	External static press.	Pa	0	0	0	0	0	0	
		mmH ₂ O	0	0	0	0	0	0	
	Motor type		DC motor						
	Motor output		kW	0.050	0.050	0.050	0.050	0.050	
	Driving mechanism		Direct-drive						
	Airflow rate (Low-Mid2- Mid1-High)	m ³ /min	12 - 13 - 14 - 15	12 - 13 - 14 - 15	13 - 14 - 15 - 16	13 - 14 - 15 - 17	13 - 14 - 16 - 18	14 - 15 - 16 - 18	
L/s		200 - 217 - 233 - 250	200 - 217 - 233 - 250	217 - 233 - 250 - 267	217 - 233 - 250 - 283	217 - 233 - 267 - 300	233 - 250 - 267 - 300		
cfm		424 - 459 - 494 - 530	424 - 459 - 494 - 530	459 - 494 - 530 - 565	459 - 494 - 530 - 600	459 - 494 - 565 - 636	494 - 530 - 565 - 636		
Sound pressure level (Low-Mid-High) (measured in anechoic room)		dB <A>		24 - 26 - 27 - 29	24 - 26 - 27 - 29	26 - 27 - 29 - 31	26 - 27 - 29 - 31	26 - 27 - 29 - 31	28 - 29 - 30 - 32
Insulation material		PS							
Air filter		PP honeycomb							
Protection device		Fuse							
Refrigerant control device		LEV							
Connectable outdoor unit		R410A CITY MULTI							
Diameter of refrigerant pipe	Liquid (R410A)	mm (inch)	φ6.35 (φ1/4) Flare	φ6.35 (φ1/4) Flare	φ6.35 (φ1/4) Flare	φ6.35 (φ1/4) Flare	φ6.35 (φ1/4) Flare	φ9.52 (φ3/8) Flare	
	Gas (R410A)	mm (inch)	φ12.7 (φ1/2) Flare	φ12.7 (φ1/2) Flare	φ12.7 (φ1/2) Flare	φ12.7 (φ1/2) Flare	φ12.7 (φ1/2) Flare	φ15.88 (φ5/8) Flare	
Field drain pipe size		mm (inch) O.D. φ32 (VP-25)							
Standard attachment		Document Accessory Installation Manual, Instruction Book							
Remark	Optional parts								
	Grille **1		PLP-6EA	PLP-6EA	PLP-6EA	PLP-6EA	PLP-6EA	PLP-6EA	
	Air outlet shutter plate		PAC-SJ37SP-E	PAC-SJ37SP-E	PAC-SJ37SP-E	PAC-SJ37SP-E	PAC-SJ37SP-E	PAC-SJ37SP-E	
	High efficiency filter element **2		PAC-SH59KF-E	PAC-SH59KF-E	PAC-SH59KF-E	PAC-SH59KF-E	PAC-SH59KF-E	PAC-SH59KF-E	
	Multi-function casement		PAC-SJ41TM-E	PAC-SJ41TM-E	PAC-SJ41TM-E	PAC-SJ41TM-E	PAC-SJ41TM-E	PAC-SJ41TM-E	
		**1. PLFY-P-VEM-E should be used together with PLP-6EA. **2. PAC-SJ41TM-E is necessary to use with filter PAC-SH59KF-E.							
Installation		Details on foundation work, duct work, insulation work, electrical wiring, power source switch, and other items shall be referred to the Installation Manual.							
*1 Nominal cooling condition		*2 Nominal cooling condition		*3 Nominal heating condition		Unit converter			
Indoor : 27°CDB/19°CWB (81°FDB/66°FWB)		27°CDB/19.5°CWB (81°FDB/67°FWB)		20°CDB (68°FDB)		kcal/h = kW × 860			
Outdoor : 35°CDB (95°FDB)		35°CDB (95°FDB)		7°CDB/6°CWB (45°FDB/43°FWB)		Btu/h = kW × 3,412			
Pipe length : 7.5 m (24-9/16 ft)		5 m (16-3/8 ft)		7.5 m (24-9/16 ft)		cfm = m ³ /min × 35.31			
Level difference : 0 m (0 ft)		0 m (0 ft)		0 m (0 ft)		lb = kg/0.4536			
Notes:		*Above specification data is subject to rounding variation.							
1. Nominal conditions*1 and *3 are subject to JIS B8615-1.									
2. Due to continuing improvement, above specification may be subject to change without notice.									

Model		PLFY-P80VEM-E	PLFY-P100VEM-E	PLFY-P125VEM-E	
Power source		1-phase 220-240V 50Hz, 1-phase 220V 60Hz			
Cooling capacity (Nominal)	*1 kW	9.0	11.2	14.0	
	*1 kcal/h	7,700	9,600	12,000	
	*1 BTU/h	30,700	38,200	47,800	
	*2 kcal/h	8,000	10,000	12,500	
	Power input	kW	0.05	0.07	0.11
	Current input	A	0.50	0.67	1.06
Heating capacity (Nominal)	*3 kW	10.0	12.5	16.0	
	*3 kcal/h	8,600	10,800	13,800	
	*3 BTU/h	34,100	42,700	54,600	
	Power input	kW	0.05	0.07	0.11
	Current input	A	0.43	0.60	0.99
External finish		Galvanized steel sheet			
External dimension H × W × D	mm	258 × 840 × 840	298 × 840 × 840		
	inch	10-3/16 × 33-3/32 × 33-3/32	11-3/4 × 33-13/32 × 33-13/32		
Net weight	kg (lb)	21(46)	24(53)	24(53)	
Grille	model	PLP-6EA	PLP-6EA	PLP-6EA	
	External finish		MUNSELL (10Y 9.2/0.2)		
	Dimension H × W × D	mm	40 × 950 × 950		
		inch	1-9/16 × 37-13/32 × 37-13/32		
	Net weight	kg (lb)	5 (11)		
Heat exchanger		Cross fin (Aluminum fin and copper tube)			
FAN	Type × Quantity		Turbo fan × 1	Turbo fan × 1	Turbo fan × 1
	External static press.	Pa	0	0	0
		mmH ₂ O	0	0	0
	Motor type		DC motor		
	Motor output	kW	0.050	0.120	0.120
	Driving mechanism		Direct-drive		
	Airflow rate (Low-Mid2- Mid1-High)	m ³ /min	14 - 17 - 20 - 23	20 - 23 - 26 - 29	22 - 26 - 30 - 35
L/s		233 - 283 - 333 - 383	333 - 383 - 433 - 483	367 - 433 - 500 - 583	
cfm		494 - 600 - 706 - 812	706 - 812 - 918 - 1024	777 - 918 - 1060 - 1236	
Sound pressure level (Low-Mid-High) (measured in anechoic room)	dB <A>	28 - 31 - 34 - 37	34 - 37 - 39- 41	35 - 39 - 42 - 45	
Insulation material		PS			
Air filter		PP honeycomb			
Protection device		Fuse			
Refrigerant control device		LEV			
Connectable outdoor unit		R410A CITY MULTI			
Diameter of refrigerant pipe	Liquid (R410A)	mm (inch)	φ9.52 (φ3/8) Flare	φ9.52 (φ3/8) Flare	φ9.52 (φ3/8) Flare
	Gas (R410A)	mm (inch)	φ15.88 (φ5/8) Flare	φ15.88 (φ5/8) Flare	φ15.88 (φ5/8) Flare
Field drain pipe size	mm (inch)	O.D. φ32 (VP-25)			
Standard attachment	Document Accessory	Installation Manual, Instruction Book			
Remark	Optional parts				
	Grille **1	PLP-6EA	PLP-6EA	PLP-6EA	
	Air outlet shutter plate	PAC-SJ37SP-E	PAC-SJ37SP-E	PAC-SJ37SP-E	
	High efficiency filter element **2	PAC-SH59KF-E	PAC-SH59KF-E	PAC-SH59KF-E	
	Multi-function casement	PAC-SJ41TM-E	PAC-SJ41TM-E	PAC-SJ41TM-E	
	**1. PLY-P-VEM-E should be used together with PLP-6EA. **2. PAC-SJ41TM-E is necessary to use with filter PAC-SH59KF-E.				
Installation	Details on foundation work, duct work, insulation work, electrical wiring, power source switch, and other items shall be referred to the Installation Manual.				
*1 Nominal cooling condition		*2 Nominal cooling condition		*3 Nominal heating condition	
Indoor : 27°CDB/19°CWB (81°FDB/66°FWB)		27°CDB/19.5°CWB (81°FDB/67°FWB)		20°CDB (68°FDB)	
Outdoor : 35°CDB (95°FDB)		35°CDB (95°FDB)		7°CDB/6°CWB (45°FDB/43°FWB)	
Pipe length : 7.5 m (24-9/16 ft)		5 m (16-3/8 ft)		7.5 m (24-9/16 ft)	
Level difference : 0 m (0 ft)		0 m (0 ft)		0 m (0 ft)	
Notes:				Unit converter	
1. Nominal conditions *1 and *3 are subject to JIS B8615-1.				kcal/h = kW × 860	
2. Due to continuing improvement, above specification may be subject to change without notice.				Btu/h = kW × 3,412	
				cfm = m ³ /min × 35.31	
				lb = kg/0.4536	
				*Above specification data is subject to rounding variation.	

3-2. ELECTRICAL PARTS SPECIFICATIONS

Service Ref. Parts name	Symbol	PLFY-P20VEM-E.UK	PLFY-P25VEM-E.UK	PLFY-P32VEM-E.UK	PLFY-P40VEM-E.UK	PLFY-P50VEM-E.UK	PLFY-P63VEM-E.UK
Room temperature thermistor	TH21	Resistance 0°C/15kΩ, 10°C/9.6kΩ, 20°C/6.3kΩ, 25°C/5.4kΩ, 30°C/4.3kΩ, 40°C/3.0kΩ					
Liquid pipe thermistor	TH22	Resistance 0°C/15kΩ, 10°C/9.6kΩ, 20°C/6.3kΩ, 25°C/5.4kΩ, 30°C/4.3kΩ, 40°C/3.0kΩ					
Gas pipe thermistor	TH23	Resistance 0°C/15kΩ, 10°C/9.6kΩ, 20°C/6.3kΩ, 25°C/5.4kΩ, 30°C/4.3kΩ, 40°C/3.0kΩ					
Fuse (Indoor controller board)	FUSE	250V 6.3A					
Fan motor	MF	8-pole OUTPUT 50W					
Vane motor	MV	MSBPC20M13 DC12V 300Ω/phase					
Drain pump	DP	PMD-12D13ME INPUT 3W 24 ℓ /Hr					
Drain float switch	FS	Open / Short detection					
Linear expansion valve	LEV	DC12V Stepping motor drive port dimension φ3.2 (0–2000pulse) EDM-40YGME					
Power supply terminal block	TB2	(L, N) Rated to 330V 30A *					
Transmission terminal block	TB5	(M1, M2, S) Rated to 250V 20A *					
MA remote controller terminal block	TB15	(1, 2) Rated to 250V 10A *					

*Refer to WIRING DIAGRAM for the supplied voltage.

Service Ref. Parts name	Symbol	PLFY-P80VEM-E.UK	PLFY-P100VEM-E.UK	PLFY-P125VEM-E.UK
Room temperature thermistor	TH21	Resistance 0°C/15kΩ, 10°C/9.6kΩ, 20°C/6.3kΩ, 25°C/5.4kΩ, 30°C/4.3kΩ, 40°C/3.0kΩ		
Liquid pipe thermistor	TH22	Resistance 0°C/15kΩ, 10°C/9.6kΩ, 20°C/6.3kΩ, 25°C/5.4kΩ, 30°C/4.3kΩ, 40°C/3.0kΩ		
Gas pipe thermistor	TH23	Resistance 0°C/15kΩ, 10°C/9.6kΩ, 20°C/6.3kΩ, 25°C/5.4kΩ, 30°C/4.3kΩ, 40°C/3.0kΩ		
Fuse (Indoor controller board)	FUSE	250V 6.3A		
Fan motor	MF	8-pole OUTPUT 50W	8-pole OUTPUT 120W	
Vane motor	MV	MSBPC20M13 DC12V 300Ω/phase		
Drain pump	DP	PMD-12D13ME INPUT 3W 24R/Hr		
Drain float switch	FS	Open / Short detection		
Linear expansion valve	LEV	DC12V Stepping motor drive port dimension φ5.2 (0–2000pulse) EDM-80YGME		
Power supply terminal block	TB2	(L, N) Rated to 330V 30A *		
Transmission terminal block	TB5	(M1, M2, S) Rated to 250V 20A *		
MA remote controller terminal block	TB15	(1, 2) Rated to 250V 10A *		

*Refer to WIRING DIAGRAM for the supplied voltage.

3-3. SOUND PRESSURE LEVEL

PLFY-P-VEM-E

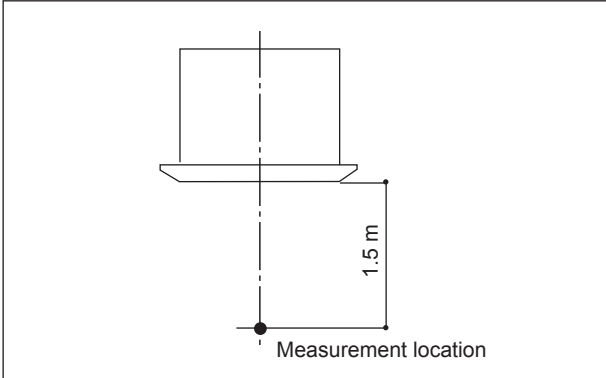

Note: Measured in anechoic room.

Sound pressure level at anechoic room : Low-Mid2-Mid1-High

Service Ref.	Sound pressure level dB (A)
PLFY-P20VEM-E.UK PLFY-P25VEM-E.UK	24-26-27-29
PLFY-P32VEM-E.UK PLFY-P40VEM-E.UK PLFY-P50VEM-E.UK	26-27-29-31
PLFY-P63VEM-E.UK	28-29-30-32
PLFY-P80VEM-E.UK	28-31-34-37
PLFY-P100VEM-E.UK	34-37-39-41
PLFY-P125VEM-E.UK	35-39-42-45

3-4. NC CURVES

**PLFY-P20VEM-E.UK
PLFY-P25VEM-E.UK**

NOTCH	SPL(dB)	LINE
High	29	○—○
Medium1	27	●—●
Medium2	26	△—△
Low	24	▲—▲

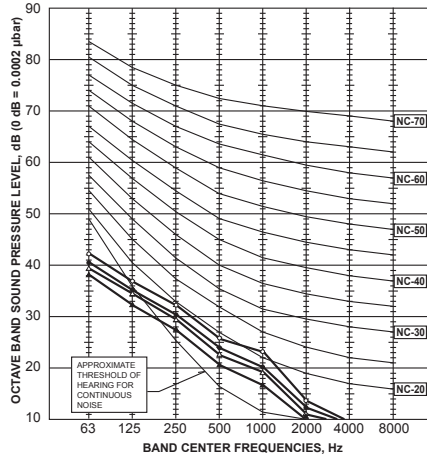

**PLFY-P32VEM-E.UK
PLFY-P40VEM-E.UK
PLFY-P50VEM-E.UK**

NOTCH	SPL(dB)	LINE
High	31	○—○
Medium1	29	●—●
Medium2	27	△—△
Low	26	▲—▲

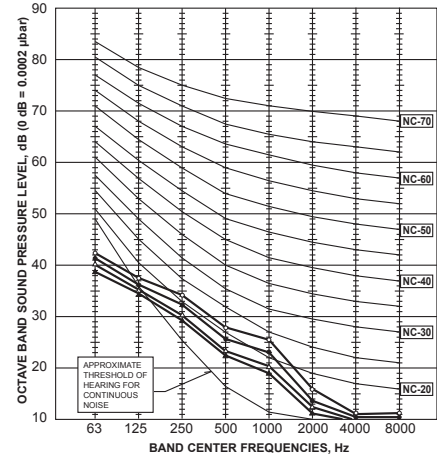

PLFY-P63VEM-E.UK

NOTCH	SPL(dB)	LINE
High	32	○—○
Medium1	30	●—●
Medium2	29	△—△
Low	28	▲—▲

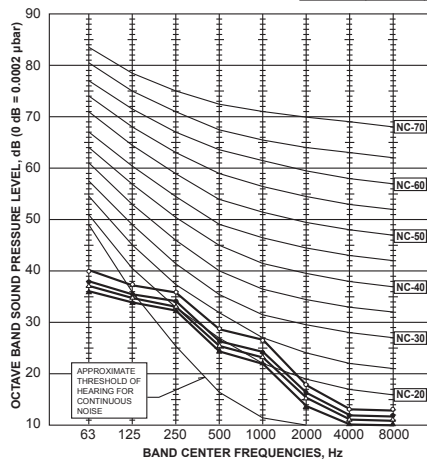

PLFY-P80VEM-E.UK

NOTCH	SPL(dB)	LINE
High	37	○—○
Medium1	34	●—●
Medium2	31	△—△
Low	28	▲—▲

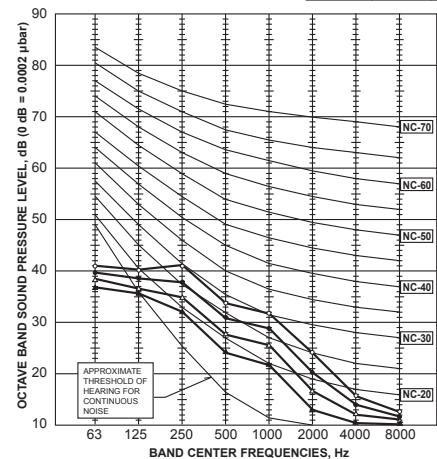

PLFY-P100VEM-E.UK

NOTCH	SPL(dB)	LINE
High	41	○—○
Medium1	39	●—●
Medium2	37	△—△
Low	34	▲—▲

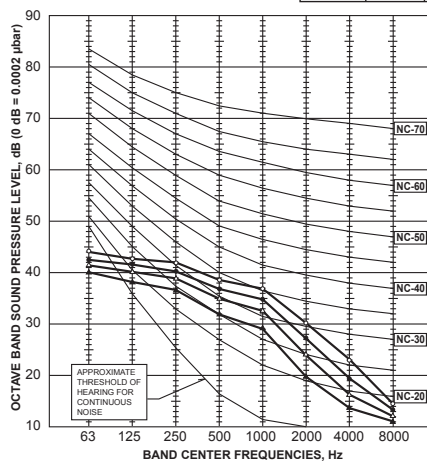

PLFY-P125VEM-E.UK

NOTCH	SPL(dB)	LINE
High	45	○—○
Medium1	42	●—●
Medium2	39	△—△
Low	35	▲—▲

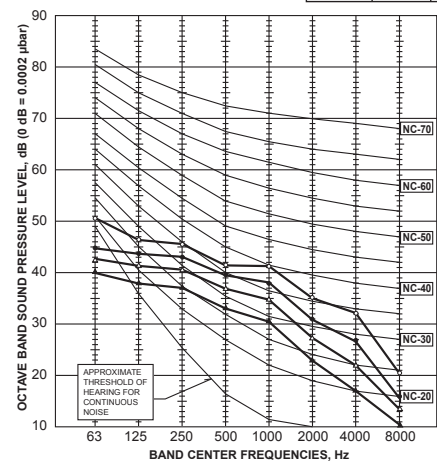

4-1. PLACEMENT OF THE AIR OUTLETS

• For this grille, the blowout direction comes in 11 patterns.

Also, by setting switch on the controller board to the appropriate settings, you can adjust the airflow and speed. Select the settings from Table1 according to the location in which you want to install the unit.

1) Decide on the pattern of the airflow direction.

<Table 1>

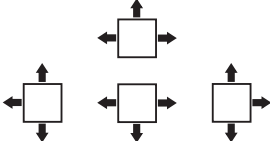
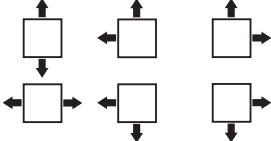
	4-direction	3-direction	2-direction
Blowout direction pattern	<p>Pattern 1 Initial setting</p> 	<p>Pattern 4 1 air outlet fully closed</p> 	<p>Pattern 6 2 air outlet fully closed</p> 

Note1.

For 3- and 2-direction settings, please use the air outlet shutter plate (option).

2) According to the number of air outlets and height of the ceiling to install the unit, be sure to set up the switch (SW21) on the circuit board to the appropriate setting.

• Correspondence of ceiling heights to the number of air outlets

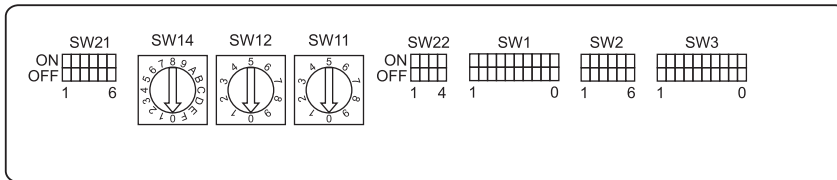

			PLFY-P20/25/32/40/50/63/80VEM-E						PLFY-P100/125VEM-E					
			Silent		Standard		High ceiling		Silent		Standard		High ceiling	
			SW21-1	SW21-2	SW21-1	SW21-2	SW21-1	SW21-2	SW21-1	SW21-2	SW21-1	SW21-2	SW21-1	SW21-2
			OFF	ON	OFF	OFF	ON	OFF	OFF	ON	OFF	OFF	ON	OFF
4 direction	SW21-3	OFF	2.5 m		2.7 m		3.5 m		2.7 m		3.2 m		4.5 m	
	SW21-4	ON												
3 direction	SW21-3	OFF	2.7 m		3.0 m		3.5 m		3.0 m		3.6 m		4.5 m	
	SW21-4	OFF												
2 direction	SW21-3	ON	3.0 m		3.3 m		3.5 m		3.3 m		4.0 m		4.5 m	
	SW21-4	OFF												

4-2. BRANCH DUCT HOLE AND FRESH AIR INTAKE HOLE

At the time of installation, use the duct holes (cut out) located at the positions shown in following diagram, as and when required.

- A fresh air intake hole for the optional multi-functional casement can also be made.

Note:

The figures marked with * in the drawing below represent the dimensions of the main unit excluding those of the optional multi-functional casement.

When installing the optional multi-functional casement, add 135 mm to the dimensions marked on the figure.

When installing the branch ducts, be sure to insulate adequately.

Otherwise, condensation and dripping may occur.

Unit : mm

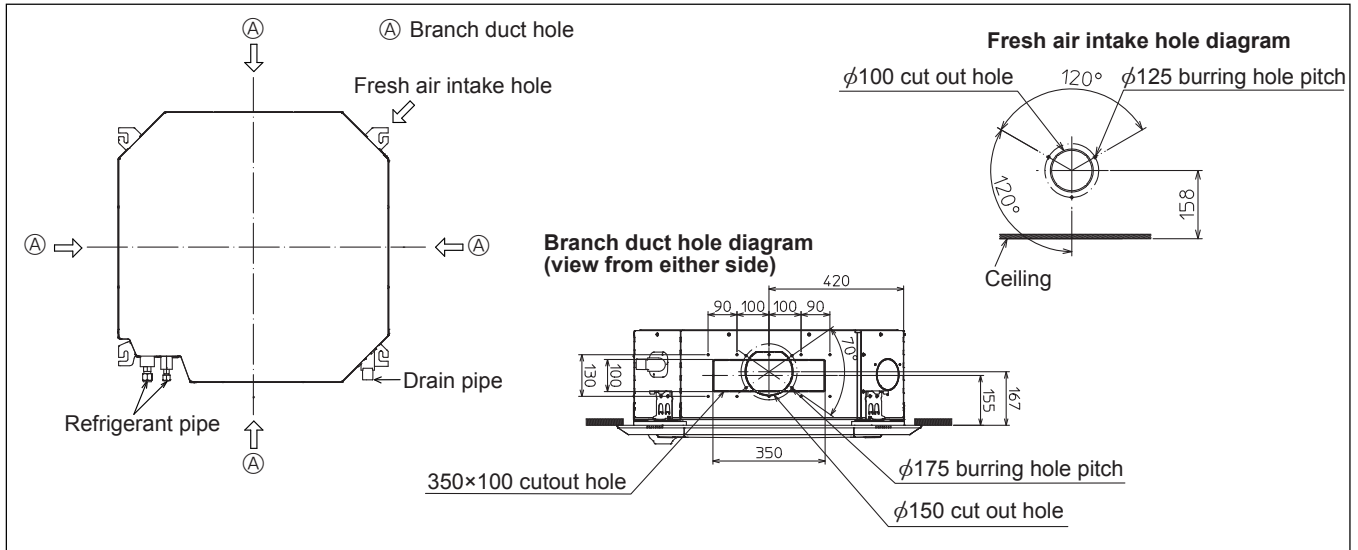

4-3. OPERATION IN CONJUNCTION WITH DUCT FAN (Booster fan)

- Whenever the indoor unit is operating, the duct fan also operates.

(1) Connect the optional multiple remote controller adapter (PAC-SA88HA-E) to the connector CN51 on the indoor controller board.

(2) Drive the relay after connecting the 12 V DC relay between the Yellow and Orange connector lines.

MB: Electromagnetic switch power relay for duct fan.

X: Auxiliary relay (For 12 V DC, coil rating: 1.0W or smaller)

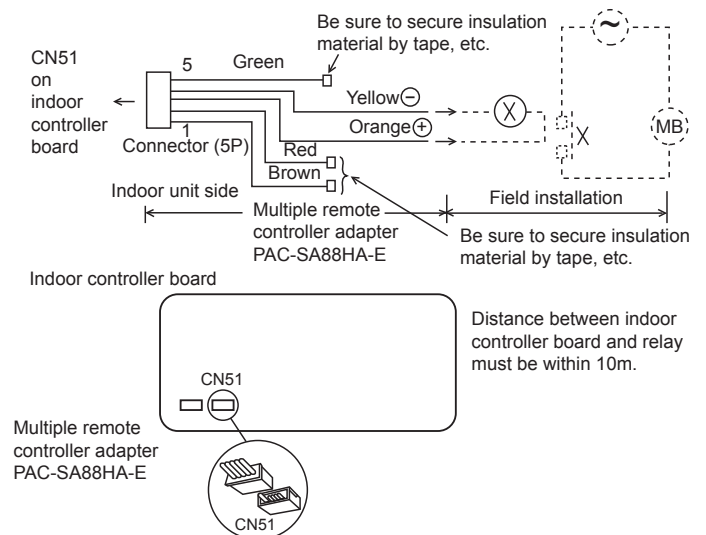

4-4. FRESH AIR INTAKE AMOUNT & STATIC PRESSURE CHARACTERISTICS

1 PLFY-P20/25/32/40/50/63/80VEM-E.UK

Multi-functional casement + Standard filter

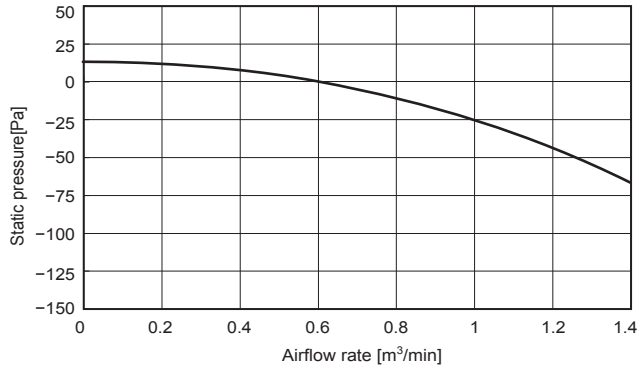

Multi-functional casement + High efficiency filter

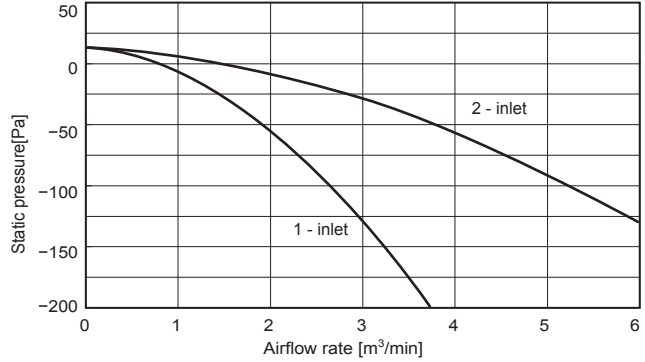

Taking air into the unit

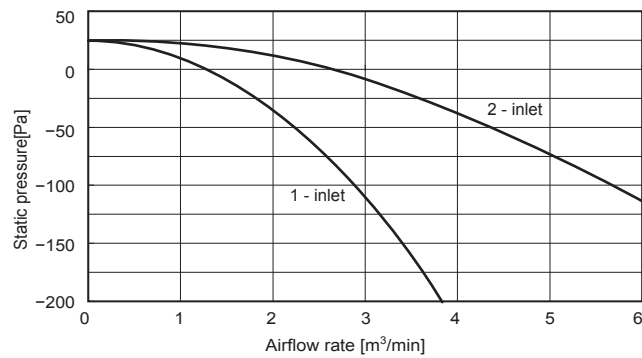

How to read curves

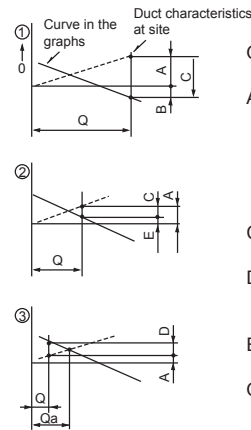

- Q...Designed amount of fresh air intake $\langle m^3/min \rangle$
- A...Static pressure loss of fresh air intake air duct system with airflow amount Q $\langle Pa \rangle$
- B...Forced static pressure at air conditioner inlet with airflow amount Q $\langle Pa \rangle$
- C...Static pressure of booster fan with airflow amount Q $\langle Pa \rangle$
- D...Static pressure loss increase amount of fresh air intake duct system for airflow amount Q $\langle Pa \rangle$
- E...Static pressure of indoor unit with airflow amount Q $\langle Pa \rangle$
- Qa...Estimated amount of fresh air intake without D $\langle m^3/min \rangle$

2 PLFY-P100/125VEM-E.UK

Multi-functional casement + Standard filter

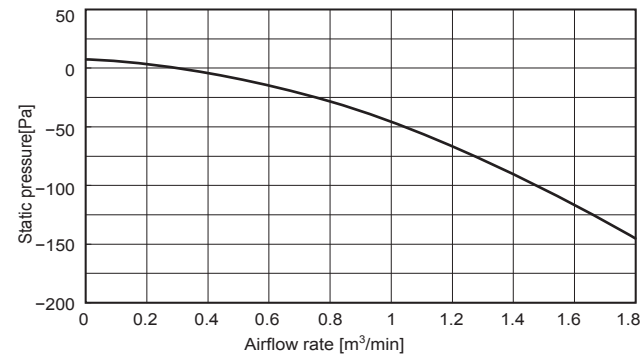

Multi-functional casement + High efficiency filter

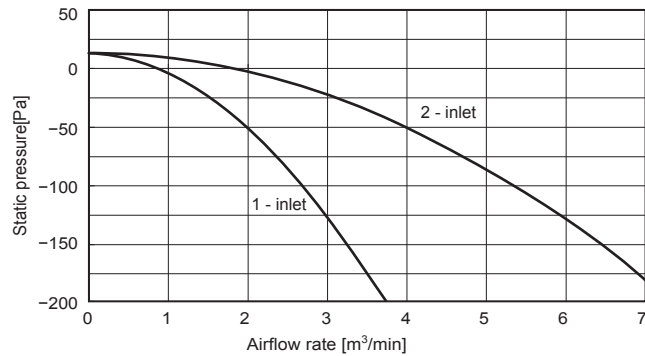

Taking air into the unit

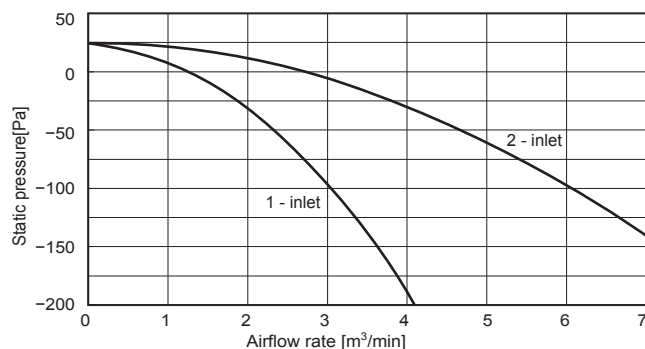

PLFY-P20VEM-E.UK PLY-P25VEM-E.UK PLY-P32VEM-E.UK PLY-P40VEM-E.UK
 PLY-P50VEM-E.UK PLY-P63VEM-E.UK PLY-P80VEM-E.UK PLY-P100VEM-E.UK
 PLY-P125VEM-E.UK

Unit: mm

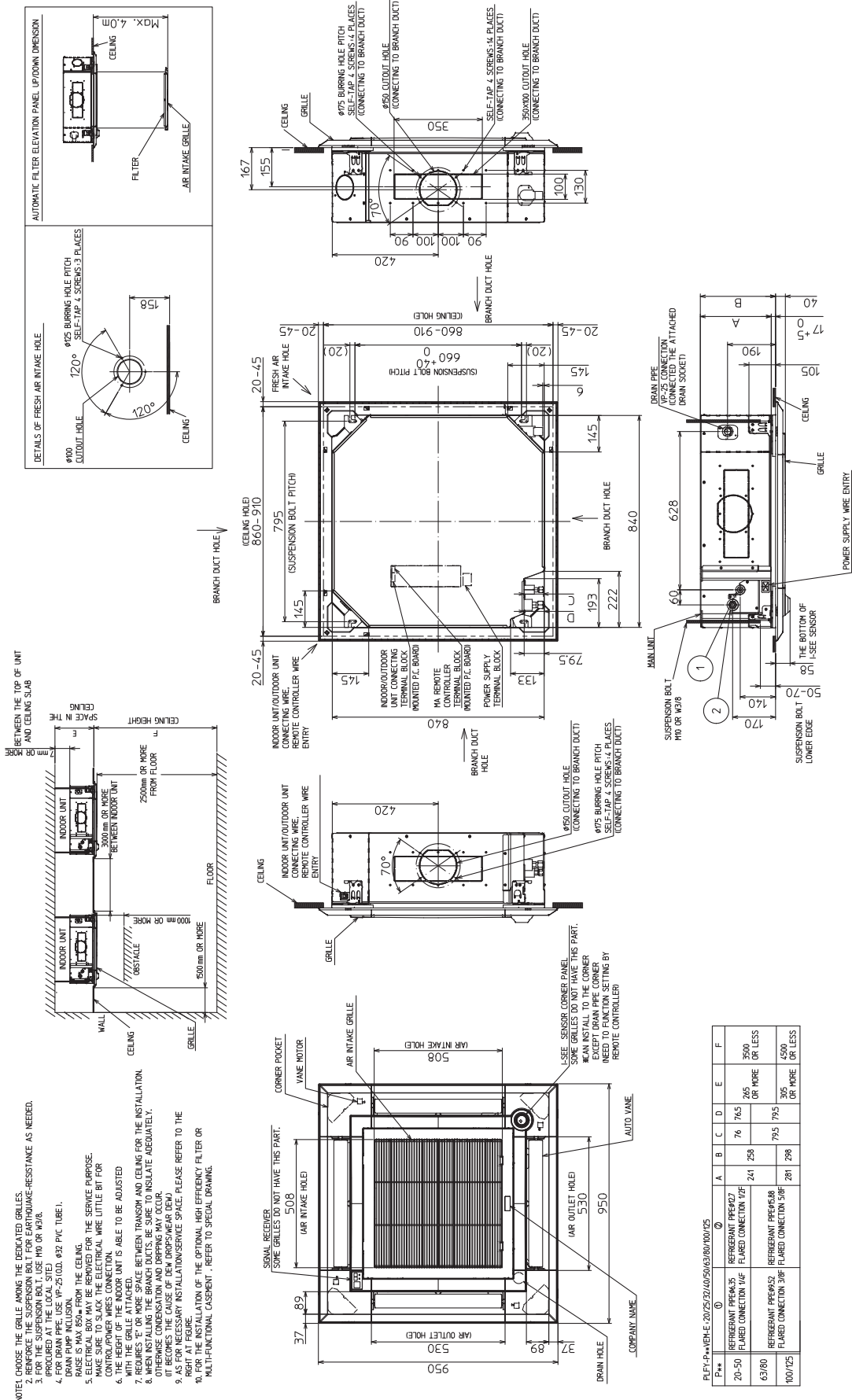

1. NOTE: CHOOSE THE GRILLE AMONG THE DEDICATED GRILLES.
2. FOR THE SUSPENSION BOLT, USE M6 OR M8.
3. FOR THE SUSPENSION BOLT, USE M6 OR M8.
4. FOR DRAIN PIPE, USE VP-25 (OD. Ø32 PVC TUBE).
5. FOR DRAIN PIPE, USE VP-25 (OD. Ø32 PVC TUBE).
6. MAKE SURE TO SLACK THE ELECTRICAL WIRE LITTLE BIT FOR CONTROL/POWER WIRES CONNECTION.
7. MAKE SURE TO SLACK THE ELECTRICAL WIRE LITTLE BIT FOR CONTROL/POWER WIRES CONNECTION.
8. WHEN INSTALLING THE BRANCH DUCTS, BE SURE TO INSULATE ADEQUATELY.
9. OTHERWISE CONDENSATION AND DRIPPING MAY OCCUR.
10. FOR THE INSTALLATION OF THE OPTIONAL HIGH EFFICIENCY FILTER OR MULTI-FUNCTIONAL CASEMENT, REFER TO SPECIAL DRAWING.

P**	Ø	A	B	C	D	E	F
REFRIGERANT PFE#K35	REFRIGERANT PFE#K27	76	76.5	265	265	3900	3900
REFRIGERANT PFE#K35	FLARED CONNECTION 1/2"	241	258	795	795	4500	4500
REFRIGERANT PFE#K35	REFRIGERANT PFE#K38	281	298	305	305	4500	4500
REFRIGERANT PFE#K35	FLARED CONNECTION 3/8"	281	298	305	305	4500	4500

PLFY-P20VEM-E.UK PLYF-P25VEM-E.UK PLYF-P32VEM-E.UK PLYF-P40VEM-E.UK
 PLYF-P50VEM-E.UK PLYF-P63VEM-E.UK PLYF-P80VEM-E.UK PLYF-P100VEM-E.UK
 PLYF-P125VEM-E.UK

[LEGEND]

SYMBOL	NAME	SYMBOL	NAME	OPTION PART
I.B	INDOOR CONTROLLER BOARD	DP	DRAIN PUMP	W.B PCB FOR WIRELESS REMOTE CONTROLLER
CN27	CONNECTOR	FS	DRAIN FLOAT SWITCH	BZ BUZZER
CN32	REMOTE SWITCH	LEV	LINEAR EXPANSION VALVE	LED1 LED (OPERATION INDICATION : GREEN)
CN51	CENTRALLY CONTROL	MF	FAN MOTOR	LED2 LED (PREPARATION FOR HEATING : ORANGE)
CN52	REMOTE INDICATION	MV	VANE MOTOR	RU RECEIVING UNIT
F1	FUSE (T 6.3AL 250V)	TH21	THERMISTOR ROOM TEMP. DETECTION (0°C/15kΩ, 25°C/5.4kΩ)	SW1 EMERGENCY OPERATION (HEAT / DOWN)
SW1	SWITCH MODE SELECTION	TH22	PIPE TEMP. DETECTION / LIQUID (0°C/15kΩ, 25°C/5.4kΩ)	SW2 EMERGENCY OPERATION (COOL / UP)
SW2	CAPACITY CODE	TH23	PIPE TEMP. DETECTION / GAS (0°C/15kΩ, 25°C/5.4kΩ)	MT I-SEE SENSOR MOTOR
SW3	MODE SELECTION	TB2	TERMINAL BLOCK POWER SUPPLY	
SW11	ADDRESS SETTING 1s DIGIT	TB5	BLOCK TRANSMISSION	
SW12	ADDRESS SETTING 10s DIGIT	TB15	MA-REMOTE CONTROLLER	
SW14	BRANCH NO.			
SW21	CEILING HEIGHT			
	DISCHARGE OUTLET NUMBER			
	OPTION SELECTOR			
SW22	PAIR NO. SETTING			
SWE	DRAIN PUMP (TEST MODE)			

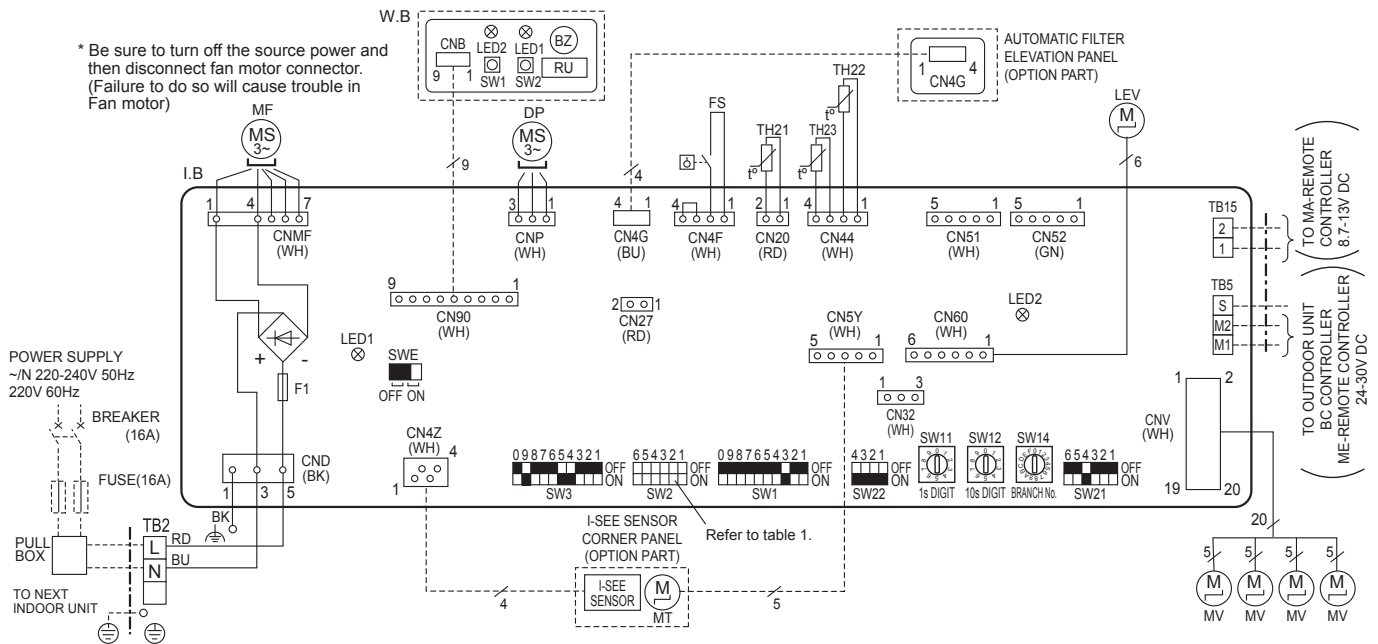

NOTES:

- At servicing for outdoor unit, always follow the wiring diagram of outdoor unit.
- In case of using MA-Remote controller, please connect to TB15. (Remote controller wire is non-polar.)
- In case of using ME-Remote controller, please connect to TB5. (Transmission line is non-polar.)
- Symbol [S]of TB5 is the shield wire connection.
- Symbols used in wiring diagram above are, : terminal block, : connector.
- The setting of SW2 differs in the capacity and model. For the detail, refer to the table 1.
- Make sure to turn off the indoor and the outdoor units before replacing indoor controller board.
- is the switch position.

<Table 1> SW2 (CAPACITY CODE)

MODELS	SW2	MODELS	SW2	MODELS	SW2
20		40		80	
25		50		100	
32		63		125	

LED on indoor board for service

Mark	Meaning	Function
LED1	Main power supply	Main Power supply (Indoor unit:220-240V AC) power on → lamp is lit
LED2	Power supply for MA-Remote controller	Power supply for MA-Remote controller on → lamp is lit

7

REFRIGERANT SYSTEM DIAGRAM

PLFY-P20VEM-E.UK PLY-P25VEM-E.UK PLY-P32VEM-E.UK PLY-P40VEM-E.UK
 PLY-P50VEM-E.UK PLY-P63VEM-E.UK PLY-P80VEM-E.UK PLY-P100VEM-E.UK
 PLY-P125VEM-E.UK

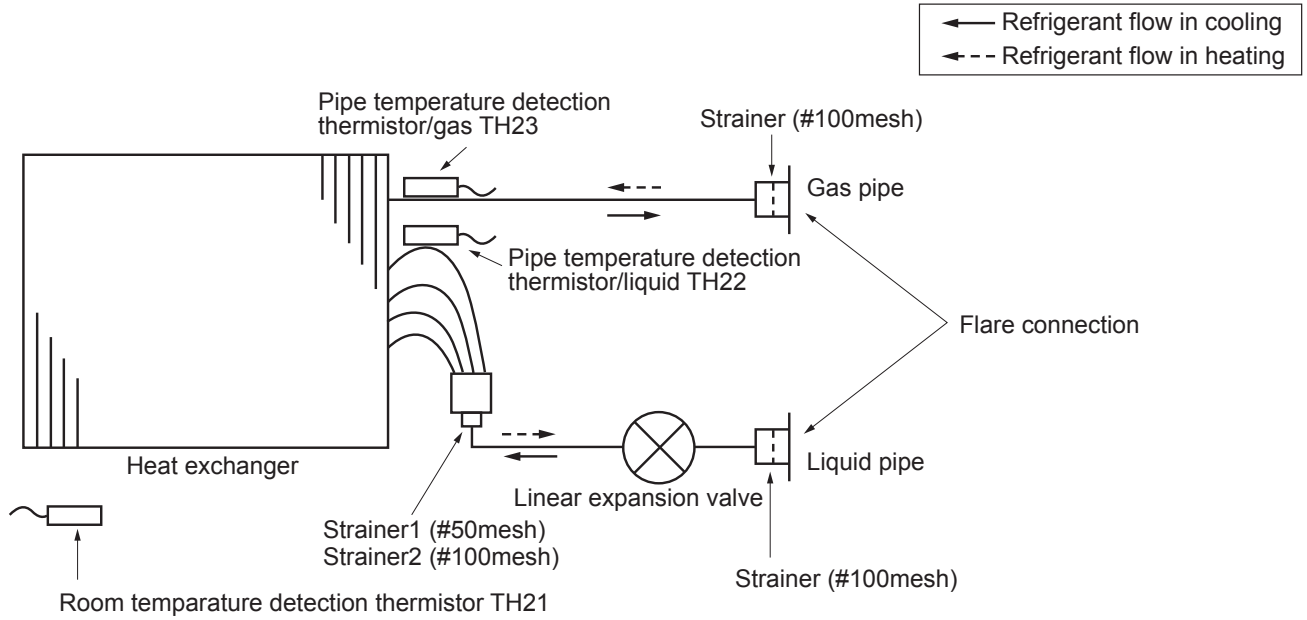

Unit : mm (inch)

Service Ref.	PLFY-P20/25/32/40/50VEM-E.UK	PLFY-P63/80/100/125VEM-E.UK
Item		
Gas pipe	$\phi 12.7$ (1/2)	$\phi 15.88$ (5/8)
Liquid pipe	$\phi 6.35$ (1/4)	$\phi 9.52$ (3/8)

8-1. HOW TO CHECK THE PARTS

PLFY-P20VEM-E.UK PLYF-P25VEM-E.UK PLYF-P32VEM-E.UK PLYF-P40VEM-E.UK
 PLYF-P50VEM-E.UK PLYF-P63VEM-E.UK PLYF-P80VEM-E.UK PLYF-P100VEM-E.UK
 PLYF-P125VEM-E.UK

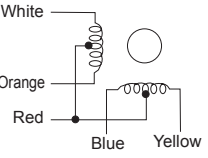
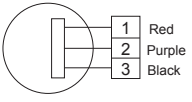
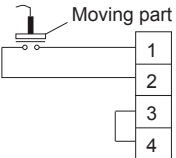
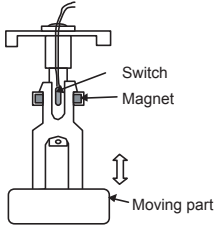
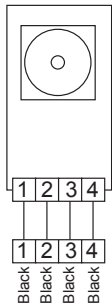
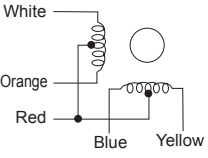
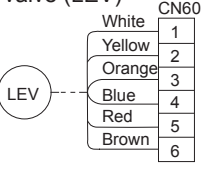
Parts name	Check points									
Room temperature detection thermistor (TH21) Pipe temperature detection thermistor/liquid (TH22) Pipe temperature detection thermistor/gas (TH23)	Disconnect the connectors, then measure the resistance with a tester. (At ambient temperatures of 10 to 30°C) <table border="1"> <thead> <tr> <th>Normal</th> <th>Abnormal</th> </tr> </thead> <tbody> <tr> <td>4.3–9.6 kΩ</td> <td>Open or short</td> </tr> </tbody> </table> (Refer to “8-1-1. Thermistor”.)	Normal	Abnormal	4.3–9.6 kΩ	Open or short					
Normal	Abnormal									
4.3–9.6 kΩ	Open or short									
Vane motor (MV) 	Measure the resistance between the terminals with a tester. (At ambient temperatures of 20 to 30°C) <table border="1"> <thead> <tr> <th>Connector</th> <th>Normal</th> <th>Abnormal</th> </tr> </thead> <tbody> <tr> <td>Red - Yellow (⑤-③, ⑩-⑧, ⑮-⑬, ⑳-⑱)</td> <td rowspan="4">300 Ω</td> <td rowspan="4">Open or short</td> </tr> <tr> <td>Red - Blue (⑤-①, ⑩-⑥, ⑮-⑪, ⑳-⑱)</td> </tr> <tr> <td>Red - Orange (⑤-④, ⑩-⑨, ⑮-⑭, ⑳-⑱)</td> </tr> <tr> <td>Red - White (⑤-②, ⑩-⑦, ⑮-⑫, ⑳-⑱)</td> </tr> </tbody> </table>	Connector	Normal	Abnormal	Red - Yellow (⑤-③, ⑩-⑧, ⑮-⑬, ⑳-⑱)	300 Ω	Open or short	Red - Blue (⑤-①, ⑩-⑥, ⑮-⑪, ⑳-⑱)	Red - Orange (⑤-④, ⑩-⑨, ⑮-⑭, ⑳-⑱)	Red - White (⑤-②, ⑩-⑦, ⑮-⑫, ⑳-⑱)
Connector	Normal	Abnormal								
Red - Yellow (⑤-③, ⑩-⑧, ⑮-⑬, ⑳-⑱)	300 Ω	Open or short								
Red - Blue (⑤-①, ⑩-⑥, ⑮-⑪, ⑳-⑱)										
Red - Orange (⑤-④, ⑩-⑨, ⑮-⑭, ⑳-⑱)										
Red - White (⑤-②, ⑩-⑦, ⑮-⑫, ⑳-⑱)										
Drain pump (DP) 	<ol style="list-style-type: none"> Check if the drain float switch works properly. Check if the drain pump works and drains water properly in cooling operation. If no water drains, confirm that the check code 2502 will not be displayed 10 minutes after the operation starts. Note: The drain pump for this model is driven by the internal DC motor of controller board, so it is not possible to measure the resistance between the terminals. Normal Red–Black: Input 13 V DC → The fan starts to rotate. Purple–Black: Abnormal (check code 2502) if it outputs 0–13 V square wave (5 pulses/rotation), and the number of rotation is not normal.									
Drain float switch (FS) 	Measure the resistance between the terminals with a tester. <table border="1"> <thead> <tr> <th>State of moving part</th> <th>Normal</th> <th>Abnormal</th> </tr> </thead> <tbody> <tr> <td>UP</td> <td>Short</td> <td>Other than short</td> </tr> <tr> <td>DOWN</td> <td>Open</td> <td>Other than open</td> </tr> </tbody> </table> 	State of moving part	Normal	Abnormal	UP	Short	Other than short	DOWN	Open	Other than open
State of moving part	Normal	Abnormal								
UP	Short	Other than short								
DOWN	Open	Other than open								
i-see Sensor 	Turn the power ON while the i-see Sensor connector is connected to the CN4Z on indoor controller board. A communication between the indoor controller board and i-see Sensor board is made to detect the connection. Normal: When the operation starts, the motor for i-see Sensor is driven to rotate the i-see Sensor. Abnormal: The motor for i-see Sensor is not driven when the operation starts. Note: The voltage between the terminals cannot be measured accurately since it is pulse output.									
i-see Sensor motor (MT) (Option) 	Measure the resistance between the terminals with a tester. (At ambient temperatures of 20 to 30°C) <table border="1"> <thead> <tr> <th>Connector</th> <th>Normal</th> <th>Abnormal</th> </tr> </thead> <tbody> <tr> <td>Red - Yellow</td> <td rowspan="4">250 Ω</td> <td rowspan="4">Open or short</td> </tr> <tr> <td>Red - Blue</td> </tr> <tr> <td>Red - Orange</td> </tr> <tr> <td>Red - White</td> </tr> </tbody> </table>	Connector	Normal	Abnormal	Red - Yellow	250 Ω	Open or short	Red - Blue	Red - Orange	Red - White
Connector	Normal	Abnormal								
Red - Yellow	250 Ω	Open or short								
Red - Blue										
Red - Orange										
Red - White										
Linear expansion valve (LEV) 	Disconnect the connector then measure the resistance valve with a tester. (At the coil temperatures of 10 to 30°C) <table border="1"> <thead> <tr> <th>Connector</th> <th>Normal</th> <th>Abnormal</th> </tr> </thead> <tbody> <tr> <td>White-Red Yellow-Brown Orange-Red Blue-Brown</td> <td>200 Ω ± 10%</td> <td>Open or short</td> </tr> </tbody> </table> Refer to “8-1-2. Linear expansion valve”.	Connector	Normal	Abnormal	White-Red Yellow-Brown Orange-Red Blue-Brown	200 Ω ± 10%	Open or short			
Connector	Normal	Abnormal								
White-Red Yellow-Brown Orange-Red Blue-Brown	200 Ω ± 10%	Open or short								

8-1-1. Thermistor

<Thermistor characteristic graph>

Thermistor for lower temperature

Room temperature detection thermistor (TH21)
 Pipe temperature detection thermistor/liquid (TH22)
 Pipe temperature detection thermistor/gas (TH23)

Thermistor $R_0=15 \text{ k}\Omega \pm 3\%$
 Fixed number of $B=3480 \pm 2\%$

$$R_t = 15 \exp \left\{ 3480 \left(\frac{1}{273+t} - \frac{1}{273} \right) \right\}$$

0°C	15 kΩ
10°C	9.6 kΩ
20°C	6.3 kΩ
25°C	5.4 kΩ
30°C	4.3 kΩ
40°C	3.0 kΩ

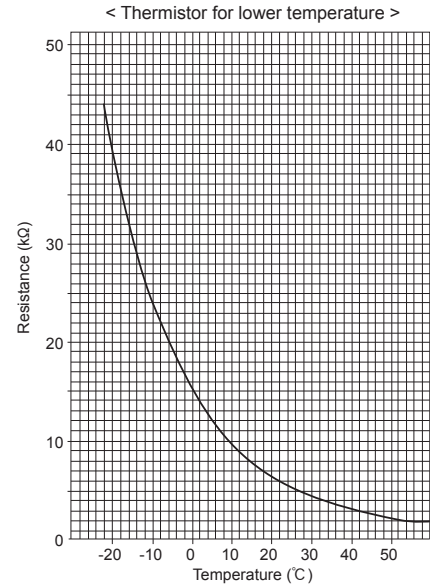

8-1-2. Linear expansion valve

① Operation summary of the linear expansion valve

- Linear expansion valves open/close through the use of a stepping motor after receiving the pulse signal from the indoor controller board.
- Valve position can be changed in proportion to the number of pulse signals.

<Connection between the indoor controller board and the linear expansion valve>

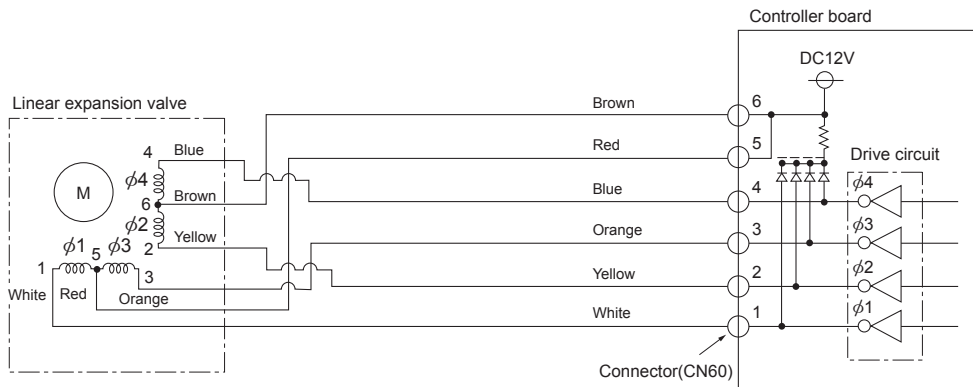

<Output pulse signal and the valve operation>

Output (Phase)	Output			
	1	2	3	4
φ1	ON	OFF	OFF	ON
φ2	ON	ON	OFF	OFF
φ3	OFF	ON	ON	OFF
φ4	OFF	OFF	ON	ON

Closing a valve : 1 → 2 → 3 → 4 → 1
 Opening a valve : 4 → 3 → 2 → 1 → 4
 The output pulse shifts in above order.

Note:

- When linear expansion valve operation stops, all output phases become OFF.
- At phase interruption or when phase does not shift in order, motor does not rotate smoothly and motor will lock and vibrate.

② Linear expansion valve operation

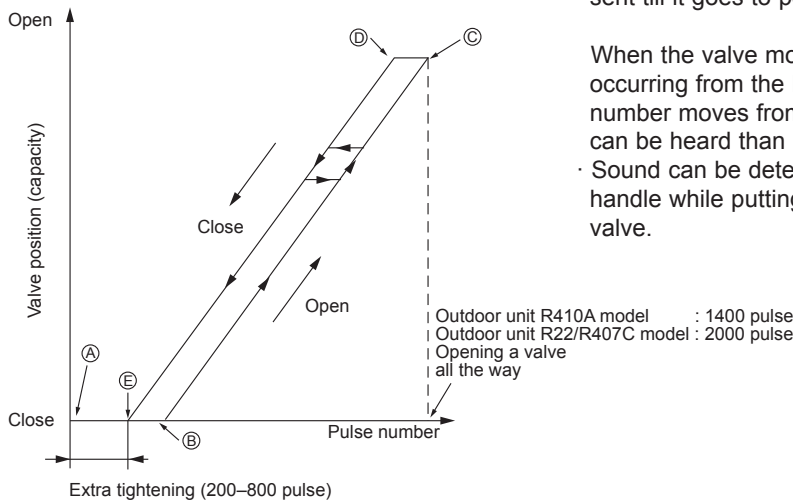

When the valve moves smoothly, there is no sound or vibration occurring from the linear expansion valves, however, when the pulse number moves from ⑤ to ④ or when the valve is locked, more sound can be heard than in a normal situation.

- Sound can be detected by placing the ear against the screw driver handle while putting the screw driver tip to the linear expansion valve.

③ Troubleshooting

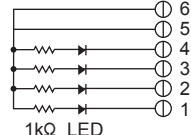
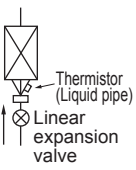
Symptom	Check points	Countermeasures
Operation circuit failure of the micro processor	Disconnect the connector on the controller board, then connect LED for checking.  1kΩ LED When power is turned on, pulse signals will output for 10 seconds. There must be some defects in the operation circuit if the LED does not light while the signals are output or keeps lighting even after the signals stop.	Exchange the indoor controller board at drive circuit failure.
Linear expansion valve mechanism is locked.	Motor will idle and make a ticking noise when the motor is operated while the linear expansion valve is locked. This ticking sound is a sign of abnormality.	Exchange the linear expansion valve.
Short or breakage of the motor coil of the linear expansion valve	Measure the resistance between each coil (white-red, yellow-brown, orange-red, blue-brown) using a tester. It is normal if the resistance is in the range of 200Ω ±10%.	Exchange the linear expansion valve.
Valve does not close completely.	To check the linear expansion valve, operate the indoor unit in fan mode and at the same time operate the other indoor units in cooling mode, then check the pipe temperature <liquid pipe temperature> of the indoor unit by the outdoor multi controller board operation monitor. During fan operation, linear expansion valve is closed completely and if there is any leaking, detecting temperature of the thermistor will go lower. If the detected temperature is much lower than the temperature indicated on the remote controller, it means the valve is not closed all the way.  Thermistor (Liquid pipe) Linear expansion valve It is not necessary to exchange the linear expansion valve, if the leakage is small and not affecting normal operation.	If a large amount of refrigerant is leaked, exchange the linear expansion valve.
Wrong connection of the connector or contact failure	Check the color of lead wire and missing terminal of the connector.	Disconnect the connector on the controller board, then check for continuity.

8-1-3. DC Fan motor (fan motor/indoor controller board)

Check method of indoor fan motor (fan motor/indoor controller board)

① Notes

- High voltage is applied to the connector (CNMF) for the fan motor. Pay attention to the service.
- Do not pull out the connector (CNMF) for the motor with the power supply on.
(It causes trouble of the indoor controller board and fan motor)

② Self check

Conditions : The indoor fan cannot rotate.

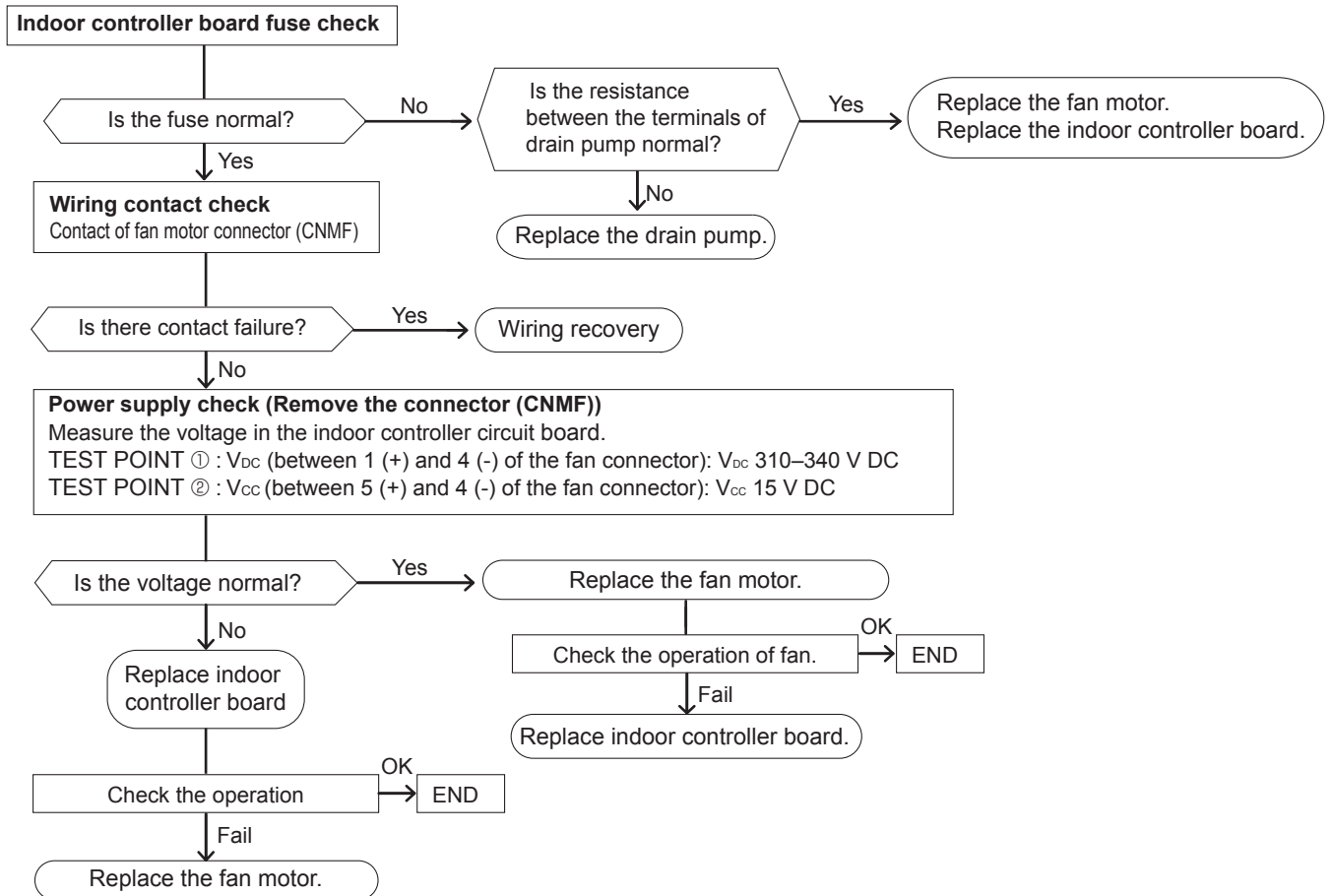

8-2. FUNCTION OF DIP SWITCH

The black square (■) indicates a switch position.

Switch	Pole	Function	Operation by switch		Effective timing	Remarks																																																																														
			ON	OFF																																																																																
SW1 Function Selection	1	Thermistor <Room temperature detection> position	Built-in remote controller	Indoor unit	Under suspension	<div style="border: 1px solid black; padding: 2px; display: inline-block;">Address board</div> <Initial setting> ON <table border="1" style="display: inline-table; vertical-align: middle;"><tr><td>1</td><td>2</td><td>3</td><td>4</td><td>5</td><td>6</td><td>7</td><td>8</td><td>9</td><td>0</td></tr></table> OFF <table border="1" style="display: inline-table; vertical-align: middle;"><tr><td>1</td><td>2</td><td>3</td><td>4</td><td>5</td><td>6</td><td>7</td><td>8</td><td>9</td><td>0</td></tr></table>	1	2	3	4	5	6	7	8	9	0	1	2	3	4	5	6	7	8	9	0																																																										
	1	2	3	4			5	6	7	8	9	0																																																																								
	1	2	3	4			5	6	7	8	9	0																																																																								
	2	Filter clogging detection	Provided	Not provided																																																																																
	3	Filter cleaning	2,500 hr	100 hr																																																																																
	4	Fresh air intake	Effective	Not effective																																																																																
	5	Switching remote display	Thermo-ON signal display	Indicating fan operation ON/OFF																																																																																
	6	—	—	—																																																																																
	7	Air flow set in case of thermo-OFF at heating mode	Low*1	Extra low*1																																																																																
	8	Auto restart function	Setting air flow*1	Depends on SW1-7																																																																																
9	Power ON/OFF by breaker	Effective	Not effective																																																																																	
0	Power ON/OFF by breaker	Effective	Not effective																																																																																	
SW2 Capacity code setting	1-6	<table border="1" style="width: 100%; text-align: center;"> <thead> <tr> <th>MODELS</th> <th>SW2</th> <th>MODELS</th> <th>SW2</th> <th>MODELS</th> <th>SW2</th> </tr> </thead> <tbody> <tr> <td>20</td> <td>ON OFF <table border="1" style="display: inline-table; vertical-align: middle;"><tr><td>1</td><td>2</td><td>3</td><td>4</td><td>5</td><td>6</td></tr></table></td> <td>40</td> <td>ON OFF <table border="1" style="display: inline-table; vertical-align: middle;"><tr><td>1</td><td>2</td><td>3</td><td>4</td><td>5</td><td>6</td></tr></table></td> <td>80</td> <td>ON OFF <table border="1" style="display: inline-table; vertical-align: middle;"><tr><td>1</td><td>2</td><td>3</td><td>4</td><td>5</td><td>6</td></tr></table></td> </tr> <tr> <td>25</td> <td>ON OFF <table border="1" style="display: inline-table; vertical-align: middle;"><tr><td>1</td><td>2</td><td>3</td><td>4</td><td>5</td><td>6</td></tr></table></td> <td>50</td> <td>ON OFF <table border="1" style="display: inline-table; vertical-align: middle;"><tr><td>1</td><td>2</td><td>3</td><td>4</td><td>5</td><td>6</td></tr></table></td> <td>100</td> <td>ON OFF <table border="1" style="display: inline-table; vertical-align: middle;"><tr><td>1</td><td>2</td><td>3</td><td>4</td><td>5</td><td>6</td></tr></table></td> </tr> <tr> <td>32</td> <td>ON OFF <table border="1" style="display: inline-table; vertical-align: middle;"><tr><td>1</td><td>2</td><td>3</td><td>4</td><td>5</td><td>6</td></tr></table></td> <td>63</td> <td>ON OFF <table border="1" style="display: inline-table; vertical-align: middle;"><tr><td>1</td><td>2</td><td>3</td><td>4</td><td>5</td><td>6</td></tr></table></td> <td>125</td> <td>ON OFF <table border="1" style="display: inline-table; vertical-align: middle;"><tr><td>1</td><td>2</td><td>3</td><td>4</td><td>5</td><td>6</td></tr></table></td> </tr> </tbody> </table>			MODELS	SW2	MODELS	SW2	MODELS	SW2	20	ON OFF <table border="1" style="display: inline-table; vertical-align: middle;"><tr><td>1</td><td>2</td><td>3</td><td>4</td><td>5</td><td>6</td></tr></table>	1	2	3	4	5	6	40	ON OFF <table border="1" style="display: inline-table; vertical-align: middle;"><tr><td>1</td><td>2</td><td>3</td><td>4</td><td>5</td><td>6</td></tr></table>	1	2	3	4	5	6	80	ON OFF <table border="1" style="display: inline-table; vertical-align: middle;"><tr><td>1</td><td>2</td><td>3</td><td>4</td><td>5</td><td>6</td></tr></table>	1	2	3	4	5	6	25	ON OFF <table border="1" style="display: inline-table; vertical-align: middle;"><tr><td>1</td><td>2</td><td>3</td><td>4</td><td>5</td><td>6</td></tr></table>	1	2	3	4	5	6	50	ON OFF <table border="1" style="display: inline-table; vertical-align: middle;"><tr><td>1</td><td>2</td><td>3</td><td>4</td><td>5</td><td>6</td></tr></table>	1	2	3	4	5	6	100	ON OFF <table border="1" style="display: inline-table; vertical-align: middle;"><tr><td>1</td><td>2</td><td>3</td><td>4</td><td>5</td><td>6</td></tr></table>	1	2	3	4	5	6	32	ON OFF <table border="1" style="display: inline-table; vertical-align: middle;"><tr><td>1</td><td>2</td><td>3</td><td>4</td><td>5</td><td>6</td></tr></table>	1	2	3	4	5	6	63	ON OFF <table border="1" style="display: inline-table; vertical-align: middle;"><tr><td>1</td><td>2</td><td>3</td><td>4</td><td>5</td><td>6</td></tr></table>	1	2	3	4	5	6	125	ON OFF <table border="1" style="display: inline-table; vertical-align: middle;"><tr><td>1</td><td>2</td><td>3</td><td>4</td><td>5</td><td>6</td></tr></table>	1	2	3	4	5	6	Before power supply ON	<div style="border: 1px solid black; padding: 2px; display: inline-block;">Indoor controller board</div> Set while the unit is off. <Initial setting> Set for each capacity.
		MODELS	SW2	MODELS	SW2	MODELS	SW2																																																																													
		20	ON OFF <table border="1" style="display: inline-table; vertical-align: middle;"><tr><td>1</td><td>2</td><td>3</td><td>4</td><td>5</td><td>6</td></tr></table>	1	2	3	4	5	6	40	ON OFF <table border="1" style="display: inline-table; vertical-align: middle;"><tr><td>1</td><td>2</td><td>3</td><td>4</td><td>5</td><td>6</td></tr></table>	1	2	3	4	5	6	80	ON OFF <table border="1" style="display: inline-table; vertical-align: middle;"><tr><td>1</td><td>2</td><td>3</td><td>4</td><td>5</td><td>6</td></tr></table>	1	2	3	4	5	6																																																											
		1	2	3	4	5	6																																																																													
		1	2	3	4	5	6																																																																													
		1	2	3	4	5	6																																																																													
		25	ON OFF <table border="1" style="display: inline-table; vertical-align: middle;"><tr><td>1</td><td>2</td><td>3</td><td>4</td><td>5</td><td>6</td></tr></table>	1	2	3	4	5	6	50	ON OFF <table border="1" style="display: inline-table; vertical-align: middle;"><tr><td>1</td><td>2</td><td>3</td><td>4</td><td>5</td><td>6</td></tr></table>	1	2	3	4	5	6	100	ON OFF <table border="1" style="display: inline-table; vertical-align: middle;"><tr><td>1</td><td>2</td><td>3</td><td>4</td><td>5</td><td>6</td></tr></table>	1	2	3	4	5	6																																																											
		1	2	3	4	5	6																																																																													
		1	2	3	4	5	6																																																																													
1	2	3	4	5	6																																																																															
32	ON OFF <table border="1" style="display: inline-table; vertical-align: middle;"><tr><td>1</td><td>2</td><td>3</td><td>4</td><td>5</td><td>6</td></tr></table>	1	2	3	4	5	6	63	ON OFF <table border="1" style="display: inline-table; vertical-align: middle;"><tr><td>1</td><td>2</td><td>3</td><td>4</td><td>5</td><td>6</td></tr></table>	1	2	3	4	5	6	125	ON OFF <table border="1" style="display: inline-table; vertical-align: middle;"><tr><td>1</td><td>2</td><td>3</td><td>4</td><td>5</td><td>6</td></tr></table>	1	2	3	4	5	6																																																													
1	2	3	4	5	6																																																																															
1	2	3	4	5	6																																																																															
1	2	3	4	5	6																																																																															
1	Heat pump/Cooling only	Cooling only	Heat pump																																																																																	
2	—	—	—																																																																																	
3	3D i-see Sensor positioning	The setting depends on the combination of SW3-3 and SW3-4. Refer to <Table B> below.																																																																																		
5	Vane horizontal angle ①	Second setting*2	First setting*2																																																																																	
6	Vane horizontal angle ②	Third setting*2	Depends on SW3-5																																																																																	
7	Changing the opening of linear expansion valve	Effective	Not effective																																																																																	
8	Heat 4 degrees up	Not effective	Effective																																																																																	
9	3D i-see Sensor ceiling height setting	The setting depends on the combination of SW3-9 and SW3-10. Refer to <Table C> below.																																																																																		
0	3D i-see Sensor ceiling height setting	The setting depends on the combination of SW3-9 and SW3-10. Refer to <Table C> below.																																																																																		
SW3 Function setting	1-6	In case of replacing the indoor controller board, make sure to set the switch to the initial setting, which is shown below.			Before power supply ON	<div style="border: 1px solid black; padding: 2px; display: inline-block;">Indoor controller board</div> <Initial setting> ON <table border="1" style="display: inline-table; vertical-align: middle;"><tr><td>1</td><td>2</td><td>3</td><td>4</td><td>5</td><td>6</td></tr></table> OFF <table border="1" style="display: inline-table; vertical-align: middle;"><tr><td>1</td><td>2</td><td>3</td><td>4</td><td>5</td><td>6</td></tr></table>	1	2	3	4	5	6	1	2	3	4	5	6																																																																		
		1	2	3			4	5	6																																																																											
		1	2	3			4	5	6																																																																											
		1	Heat pump/Cooling only	Cooling only			Heat pump																																																																													
		2	—	—			—																																																																													
		3	3D i-see Sensor positioning	The setting depends on the combination of SW3-3 and SW3-4. Refer to <Table B> below.																																																																																
		5	Vane horizontal angle ①	Second setting*2			First setting*2																																																																													
6	Vane horizontal angle ②	Third setting*2	Depends on SW3-5																																																																																	
7	Changing the opening of linear expansion valve	Effective	Not effective																																																																																	
8	Heat 4 degrees up	Not effective	Effective																																																																																	
9	3D i-see Sensor ceiling height setting	The setting depends on the combination of SW3-9 and SW3-10. Refer to <Table C> below.																																																																																		
0	3D i-see Sensor ceiling height setting	The setting depends on the combination of SW3-9 and SW3-10. Refer to <Table C> below.																																																																																		
SW4 Model selection	1-6	In case of replacing the indoor controller board, make sure to set the switch to the initial setting, which is shown below.			Before power supply ON	<div style="border: 1px solid black; padding: 2px; display: inline-block;">Indoor controller board</div>																																																																														
		1	Heat pump/Cooling only	Cooling only			Heat pump																																																																													
		2	—	—			—																																																																													
		3	3D i-see Sensor positioning	The setting depends on the combination of SW3-3 and SW3-4. Refer to <Table B> below.																																																																																
		5	Vane horizontal angle ①	Second setting*2			First setting*2																																																																													
		6	Vane horizontal angle ②	Third setting*2			Depends on SW3-5																																																																													

<Table A>

SW1-7	SW1-8	
OFF	OFF	Extra low
ON	OFF	Low
OFF	ON	Setting air flow
ON	ON	stop

<Table B>

SW3-3	SW3-4	
OFF	OFF	Setting ①
ON	OFF	Setting ②
OFF	ON	Setting ③
ON	ON	Setting ④

<Table C>





SW3-9	SW3-10	
OFF	OFF	Low ceiling
ON	OFF	Standard
OFF	ON	High ceiling
ON	ON	(High ceiling)

<Table D>

SW3-5	SW3-6	Vane setting	Initial setting	Setting	Vane position
OFF	OFF	Setting ①		Standard	Standard
ON	OFF	Setting ②	●	Less draft*3	Upward position than the standard
OFF	ON	Setting ③		Less smudging	Downward position than the standard
ON	ON	Unused		—	—

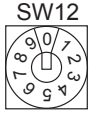
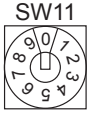
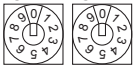
*3 Be careful of the smudge on ceiling.



Switch	Pole	Function	Operation by switch		Effective timing	Remarks
			ON	OFF		
SW11 1s digit address setting SW12 10s digit address setting	Rotary switch	  10 1	Address setting should be done when M-NET remote controller is being used.		Before power supply ON	<div style="border: 1px solid black; padding: 2px; display: inline-block;">Indoor controller board</div> <Initial setting> 
SW14 Connection No. setting	Rotary switch	 SW14	This is the switch to be used when the indoor unit is operated with R2 series outdoor unit as a set.			<div style="border: 1px solid black; padding: 2px; display: inline-block;">Indoor controller board</div> <Initial setting> 
SW21 Function Selection	1	Setting the ceiling height	Depending on the combination of SW21-1 and SW21-2. Refer to <Table E> below.		Under suspension	<div style="border: 1px solid black; padding: 2px; display: inline-block;">Indoor controller board</div> <Initial setting> 
	2	Setting the ceiling height				
	3	Setting the number of air outlet	Depending on the combination of SW21-3 and SW21-4. Refer to <Table E> below.			
	4	Setting the number of air outlet				
	5	Setting for optional parts	Option	Standard		
	6	Not used	Not used	Not used		

<Table E>

Ceiling height			PLFY-P20/25/32/40/50/63/80VEM-E						PLFY-P100/125VEM-E					
			Low ceiling		Standard		High ceiling		Low ceiling		Standard		High ceiling	
			SW21-1	SW21-2	SW21-1	SW21-2	SW21-1	SW21-2	SW21-1	SW21-2	SW21-1	SW21-2	SW21-1	SW21-2
Blowout directions			OFF	ON	OFF	ON	OFF	ON	OFF	ON	OFF	ON	OFF	ON
4 directions	SW21-3 OFF		2.5 m		2.7 m		3.5 m		2.7 m		3.2 m		4.5 m	
	SW21-4 ON													
3 directions	SW21-3 OFF		2.7 m		3.0 m		3.5 m		3.0 m		3.6 m		4.5 m	
	SW21-4 ON													
2 directions	SW21-3 OFF		3.0 m		3.3 m		3.5 m		3.3 m		4.0 m		4.5 m	
	SW21-4 ON													

Note: The setting with indicates the initial setting; To change it to other than , switch setting is necessary.

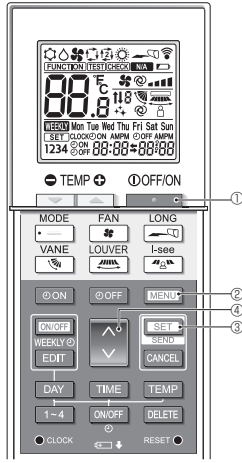
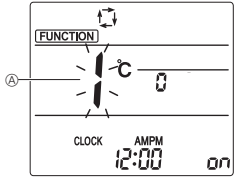
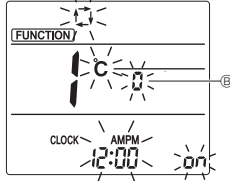
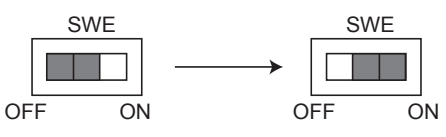
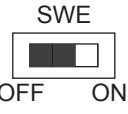

Switch	Pole	Function	Operation by switch		Effective timing	Remarks																		
			ON	OFF																				
SW22 Function selection	Switch	<table border="1"> <thead> <tr> <th>Function</th> <th>ON</th> <th>OFF</th> </tr> </thead> <tbody> <tr> <td>1</td> <td>—</td> <td>—</td> </tr> <tr> <td>2</td> <td>—</td> <td>—</td> </tr> <tr> <td>3 Pair No. of wireless remote controller</td> <td colspan="2">Depends on the combination of SW22-3 and 22-4</td> </tr> <tr> <td>4 Pair No. of wireless remote controller</td> <td colspan="2">Depends on the combination of SW22-3 and 22-4</td> </tr> </tbody> </table>	Function	ON	OFF	1	—	—	2	—	—	3 Pair No. of wireless remote controller	Depends on the combination of SW22-3 and 22-4		4 Pair No. of wireless remote controller	Depends on the combination of SW22-3 and 22-4				Under operation or suspension	<p><Initial setting></p>  <p>Fig. 1</p>  <p>Fig. 2</p> 			
		Function	ON	OFF																				
1	—	—																						
2	—	—																						
3 Pair No. of wireless remote controller	Depends on the combination of SW22-3 and 22-4																							
4 Pair No. of wireless remote controller	Depends on the combination of SW22-3 and 22-4																							
<ul style="list-style-type: none"> To operate each indoor unit by each remote controller when installed 2 indoor units or more are near, Pair No. setting is necessary. <ul style="list-style-type: none"> Pair No. setting is available with the 4 patterns. Make setting for SW22-3, 22-4 of indoor controller board and the Pair No. of wireless remote controller. You may not set it when operating it by one remote controller. <ol style="list-style-type: none"> Setting for indoor unit <ul style="list-style-type: none"> Set SW22-3, 22-4 on the indoor controller board according to the table below. Wireless remote controller pair number: <ul style="list-style-type: none"> Setting operation (Fig. 1 A) <ol style="list-style-type: none"> Press the [] button ① to stop the air conditioner. Press the [MENU] button ②. Check that function No."1" is displayed, and then press the [SET] button ③. The Screen display setting screen will be displayed. (Fig. 2.) Pair No. changing operation (Fig. 2 B) <ol style="list-style-type: none"> Press the [] button ④. Each time the [] button ④ is pressed, the pair No.0-3 changes. Press the [SET] button ③ to check the setting. Press the [MENU] button ②. <table border="1"> <thead> <tr> <th colspan="2">Indoor unit SW22</th> <th rowspan="2">Pair No. of wireless remote controller</th> <th rowspan="2"></th> </tr> <tr> <th>SW22-3</th> <th>SW22-4</th> </tr> </thead> <tbody> <tr> <td>ON</td> <td>ON</td> <td>0</td> <td>Initial setting</td> </tr> <tr> <td>OFF</td> <td>ON</td> <td>1</td> <td>—</td> </tr> <tr> <td>ON</td> <td>OFF</td> <td>2</td> <td>—</td> </tr> <tr> <td>OFF</td> <td>OFF</td> <td>3-9</td> <td>—</td> </tr> </tbody> </table>	Indoor unit SW22		Pair No. of wireless remote controller		SW22-3	SW22-4	ON	ON	0	Initial setting	OFF	ON	1	—	ON	OFF	2	—	OFF	OFF	3-9	—		
Indoor unit SW22		Pair No. of wireless remote controller																						
SW22-3	SW22-4																							
ON	ON	0	Initial setting																					
OFF	ON	1	—																					
ON	OFF	2	—																					
OFF	OFF	3-9	—																					
SWE Test run for Drain pump	Connector	<p>Drain pump and fan are activated simultaneously after the connector SWE is set to ON and turn on the power.</p>  <p>The connector SWE is set to OFF after test run.</p>			Under operation	<p><Initial setting></p> 																		

8-3. TEST POINT DIAGRAM Indoor controller board

PLFY-P20VEM-E.UK
PLFY-P50VEM-E.UK
PLFY-P125VEM-E.UK

PLFY-P25VEM-E.UK
PLFY-P63VEM-E.UK

PLFY-P32VEM-E.UK
PLFY-P80VEM-E.UK

PLFY-P40VEM-E.UK
PLFY-P100VEM-E.UK



9-1. OPERATION (AUTOMATIC FILTER ELEVATION GRILLE: PLP-6EAJ/PLP-6EAJE)

(1) Normal operation

① UP/DOWN

Air intake grille is raised/lowered by commands of UP and DOWN.
 Air intake grille does not move under the state of no-load detection or obstacle detection.
 Air intake grille stops automatically at the set lowering distance from the ceiling level.

② STOP

It stops in the cases below :

- When it reaches the set lowering distance from the ceiling level.
 It automatically stops after a predetermined period of lowering.
- When it is stored in the panel.
 The air intake grille is judged to be stored in the panel when the storage detection switch is pressed for 5 seconds continuously.
- When receiving commands of STOP, DOWN while moving up or UP while moving down.
 The STOP button is only available on the automatic filter elevation panel remote controller.
 When the wired remote controller is used, there will be a slight delay in stopping due to transmission speed.
- When both string 1b and 2b are not loaded.
 Only the string b in each UP/DOWN Machine has a tension detection switch.

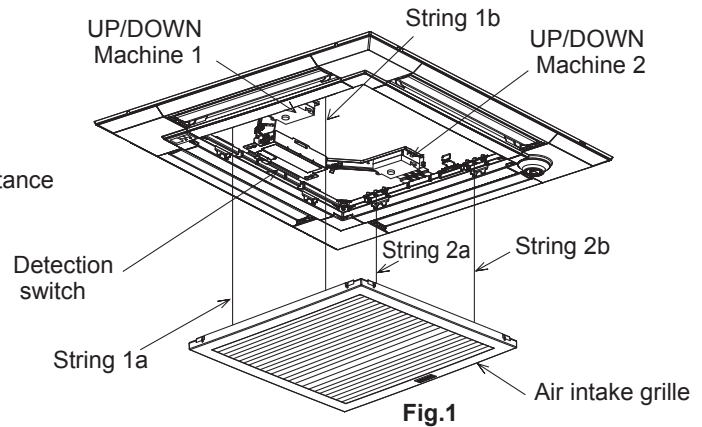

(2) Special operation

① Re-storage operation

Case : Obstruction of the raising air intake grille before storage or malfunction of storage detection switch
 Re-storage operation will be performed when the intake grille has been raised the set distance but the storage detection switch is not engaged.

In this case, the operation below will be repeated up to 4 times.

10 cm down → 30 cm up → … → 10 cm down → 30 cm up

② No-load detection

Case : UP/DOWN commands with no grille suspended.

When both string 1b and string 2b are not loaded, the strings will not move.

③ Obstacle detection

Case : Making contact with something while lowering.

Should the loads on the string 1b and string 2b be removed due to the air intake grille making contact with something while lowering, the lowering operation will stop. The air intake grille will then be raised 10 cm and stop again.

[EMERGENCY OPERATION]

1. If the wireless remote controller for ELEVATION PANEL is faulty or lost, operation will be possible using the emergency up/down switch at the wireless signal receiver or wired remote controller.
 - For the operation using the emergency up/down switch at the wireless signal receiver, refer to SW1 and SW2 on the [LEGEND] in the next page.
2. When machine for ELEVATION PANEL breaks down, a intake grille is fixed for a while, and the operation of the unit can be done.
 - Refer to installation manual with the grille for the details such as an installation method.

9-2. ELECTRICAL CIRCUIT (Controller board and wiring diagram (Panel))

9-2-1 DIP SW

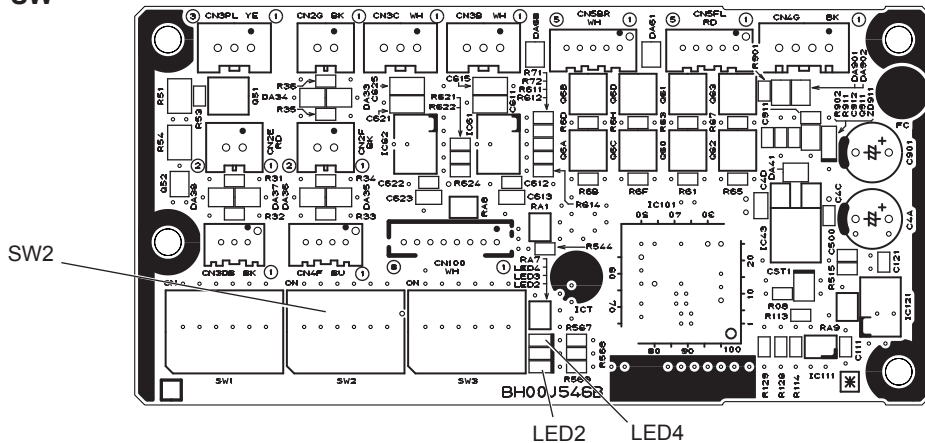

[LEGEND]

SYMBOL	NAME
U.B	ELEVATION PANEL CONTROLLER BOARD
LED2	LED ORANGE (INTAKE GRILLE CONDITION (See table *1))
LED4	LED GREEN (COMMUNICATION WITH INDOOR UNIT)
U.K 1	ELEVATION MACHINE
M	MOTOR (ELEVATION)
LS21	DETECTION SWITCH (STRING TENSION)
I.B	INDOOR UNIT CONTROLLER BOARD
W.B	PCB OF SIGNAL RECEIVER
BZ	BUZZER
RU	RECEIVING UNIT
LED1	LED GREEN (OPERATION INDICATION)
LED2	LED ORANGE (PREPARATION FOR HEATING)
SW1	EMERGENCY HEATING (LONG PRESS FOR OVER 2SEC.) (INTAKE GRILLE/DOWN (SHORT PRESS))
SW2	EMERGENCY COOLING (LONG PRESS FOR OVER 2SEC.) (INTAKE GRILLE/UP (SHORT PRESS))
LS1	DETECTION SWITCH (INTAKE GRILLE STORAGE)
R.B	WIRED REMOTE CONTROLLER

<2>SW2 on U.B

LOWERING DISTANCE	SET UP	LOWERING DISTANCE	SET UP
1.2m	ON OFF [■][■][■][■] 1 2 3 4 5 6	2.8m	ON OFF [■][■][■][■] 1 2 3 4 5 6
1.8m (Initial setting)	ON OFF [■][■][■][■] 1 2 3 4 5 6	3.2m	ON OFF [■][■][■][■] 1 2 3 4 5 6
2.0m	ON OFF [■][■][■][■] 1 2 3 4 5 6	3.6m	ON OFF [■][■][■][■] 1 2 3 4 5 6
2.4m	ON OFF [■][■][■][■] 1 2 3 4 5 6	4.0m	ON OFF [■][■][■][■] 1 2 3 4 5 6

Note: The actual lowering distance might be different from the distance in the table 2 since it can also be set using the wired remote controller.

[EMERGENCY OPERATION]

- If the wireless remote controller for ELEVATION PANEL is faulty or lost, operation will be possible using the emergency up/down switch at the wireless signal receiver or wired remote controller.
 - For the operation using the emergency up/down switch at the wireless signal receiver, refer to SW1 and SW2 on the left [LEGEND].
- When machine for ELEVATION PANEL breaks down, an intake grille is fixed for a while, and the operation of the unit can be done.
 - Refer to installation manual with the grille for the details such as an installation method.

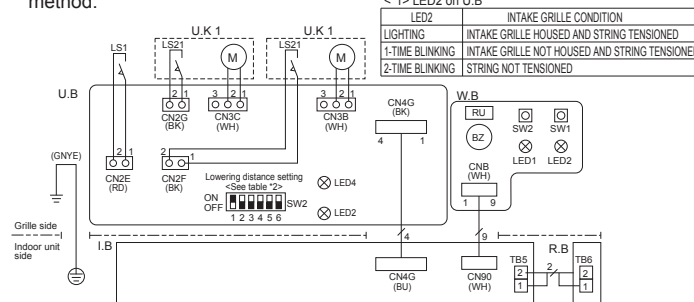

[Note]

- Symbols used in wiring diagram above are, [○ ○ ○] : Connector, [□ □ □] : Terminal (block).
- The black square (■) indicates a switch position.

9-2-2. Check point of trouble

<LED 2 Orange display>

- Turn OFF : No power supply
- Blink : Storage detection switch ON (short)
- One blink : Storage detection switch OFF (open)
- Two blinks : Tension detection switch OFF (open)

<LED 4 Green display>

- Blink : Connecting

<controller board>

Check item	Check point	Normal	Remarks
Up/down controller P.C. board supply voltage	CN4A (between 1-2)	11-14 V AC	—
Up/down machine supply voltage	CN3B (between 1-2) CN3C (between 1-2)	10-13.5 V DC	Check when instructing up/down with LED blinking once.

<Up/down machine>

Check item	Check point	Normal	Check contents
Storage detection switch	CN2E	open or short	Check if it is short when pressing push switch.
Tension detection switch	CN2F, CN2G	open or short	Check if it is short when string b is tensioned.
Motor	CN3B, CN3C	5-20 Ω	Check if it is not open or short.
Entwining strings	Pull string	Retention: about 2 kgf	Check if string is drawn out by pulling with 4 kgf.

9-3. TROUBLESHOOTING

- Check the following points.

Problem	Possible Reason	Corrective Action
Intake grille does not function with operation of the remote controller.	Air-conditioner is running.	Stop running the air-conditioner and try again.
	Power failure.	After recovering from power failure, try again.
	Batteries are not inserted into the wireless remote controller. Or battery power is running low.	Install or replace the battery.
	There is something on the intake grille. Or something is stuck in the intake grille.	Remove the objects or obstacles from the intake grille. Or, remove the stuck object.
Intake grille cannot be placed in the correct position.	There is something on the intake grille.	Remove the objects or obstacles from the intake grille.
	Filter is not properly installed.	Lower the intake grille again and check whether the filter is installed in the correct position.
	Intake grille is not hung with all 4 hooks.	Lower the intake grille again and hang the hook on the intake grille.
Intake grille stops lowering in mid flow. (Intake grille would not lower any further.)	Because the intake grille has finished lowering to the auto-stop position.	This is normal. Note: If you want to change the setting for the lowering distance, contact your dealer.
Noises are made during up/down operation. (While intake grille is moving up/down.)	This is the noise made when the string is winded and unwound.	This is normal.
Noises are made while placing the intake grille in.	This is the operational noise for placing the intake grille in securely.	
Intake grille repeats rising and lowering several times while being placed in the correct position.	This is the operation for placing the intake grille in securely.	
Intake grille leans toward one side during the up/down operation.	The speeds of winding each string is slightly different.	

10

DISASSEMBLY PROCEDURE

PLFY-P20VEM-E.UK PLY-P25VEM-E.UK PLY-P32VEM-E.UK PLY-P40VEM-E.UK
 PLY-P50VEM-E.UK PLY-P63VEM-E.UK PLY-P80VEM-E.UK PLY-P100VEM-E.UK
 PLY-P125VEM-E.UK

Be careful when removing heavy parts.

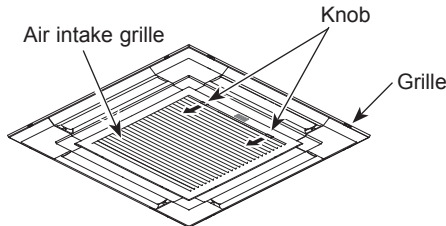
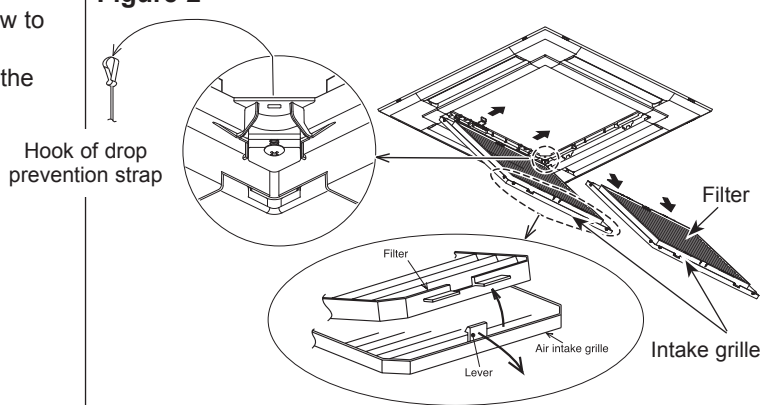
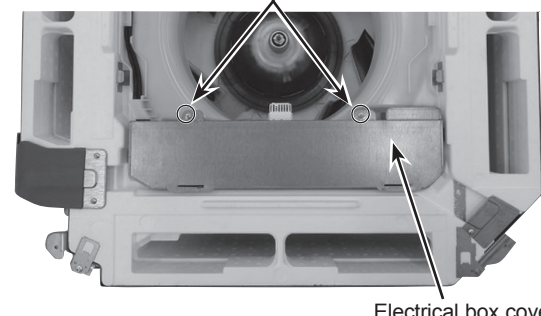
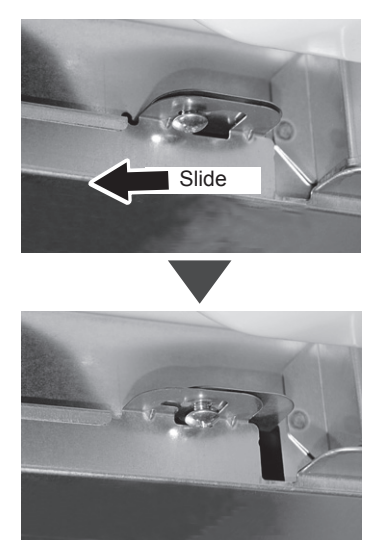
OPERATING PROCEDURE	PHOTOS & ILLUSTRATIONS
<p>1. Removing the filter</p> <ol style="list-style-type: none"> (1) Slide the knob of air intake grille toward the arrow to open the air intake grille. (See Figure 1) (2) Pull down the lever of the air intake grille to remove the filter. (See Figure 2) 	<p>Figure 1</p> 
<p>2. Removing the air intake grille</p> <ol style="list-style-type: none"> (1) Slide the knob of air intake grille toward the arrow to open the air intake grille. (See Figure 1) (2) Remove the hook of drop prevention strap from the panel. (3) Remove the air intake grille. 	<p>Figure 2</p> 
<p>3. Removing the electrical box cover</p> <ol style="list-style-type: none"> (1) Remove the air intake grille and the filter. (Refer to procedure 2) (2) Loosen the 2 electrical box cover fixing screws (M4×10) approximately 2 to 3 mm. (See Photo 1) (3) Slide the electrical box cover toward the arrow to remove. (See Photo 2) 	<p>Photo 1</p>  <p>Photo 2</p> 

OPERATING PROCEDURE

4. Removing the room temperature thermistor (TH21)

- (1) Remove the electrical box cover. (See Photo 1 and 2)
- (2) Disconnect the connector CN20 (Red) from the indoor controller board.
- (3) Remove the room temperature thermistor with its holder. (See Photo 4)

PHOTOS

Photo 3

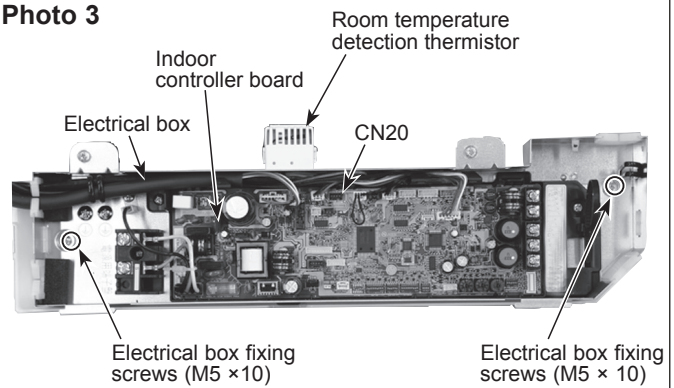
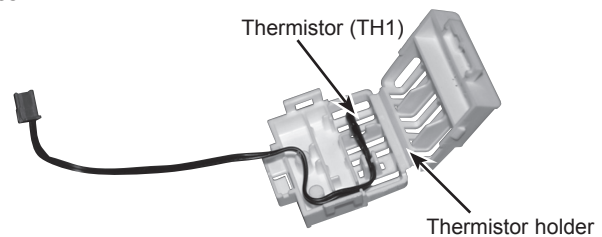

Photo 4



5. Removing the indoor controller board (I.B)

- (1) Remove the electrical box cover. (See Photo 1 and 2)
- (2) Disconnect the connectors:
 - CNMF (White) for fan motor
 - CNV (White) for vane motor
 - CN5Y (White) for motor for i-see Sensor (Option)
 - CN4Z (White) for sensor for i-see Sensor (Option)
 - CN90 (White) for signal receiver (Option)
 - CNP (White) for drain pump
 - CN4F (White) for float switch
 - CN44 (White) for thermistor (TH22/TH23)
 - CN60 (White) for LEV
 - CN01 (Black) for Indoor/Outdoor connecting line
 - CN3C (Blue) for Indoor/Outdoor transmission

Disconnect the connectors for optional parts, if any.

- (3) Disconnect the lead wire connected to the TB5 on the indoor controller board.
 - TB5: M-NET transmission connecting wire
- (4) For the unit controlled with the wireless remote controller, disconnect the lead wire connected to the TB15 on the indoor controller board.
- (5) Remove the indoor controller board (3 holders/4 hooks). (See Photo 5)

Photo 5

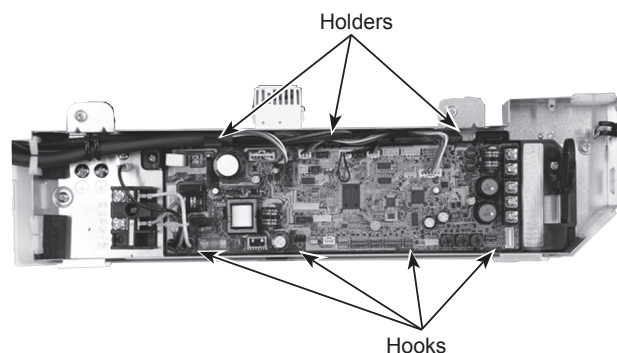

OPERATING PROCEDURE

PHOTOS & ILLUSTRATIONS

6. Removing the electrical box

- (1) Remove the electrical box cover (See Photo 1 and 2) and the connectors (Refer to procedure 5).
- (2) Remove the electrical box fixing screws (M5×10: 2 screw). (See Photo 3)
- <Electrical parts in the electrical box>
 - Terminal block for earth and reactor
 - Indoor controller board
 - Thermistor (TH)
- (3) Remove the electrical box (2 hooks).

Photo 6

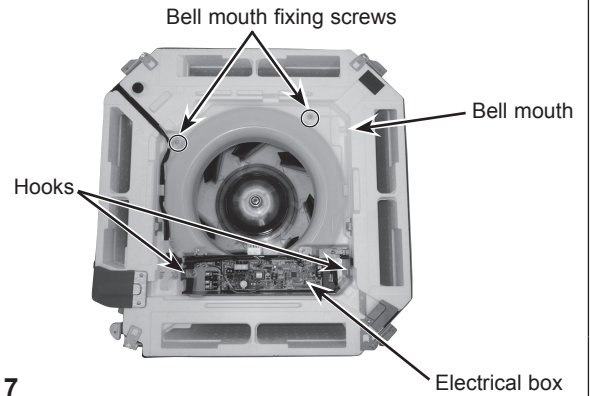

7. Removing the turbo fan

- (1) Remove the electrical box. (See Photo 3 and refer to procedure 6)
- (2) Remove the bell mouth (tapping screw 4×10: 2 screws). (See Photo 6)
- (3) Remove the nut and washer (1 nut). (See Photo 7 and 8)
- (4) Remove the turbo fan.

Photo 7

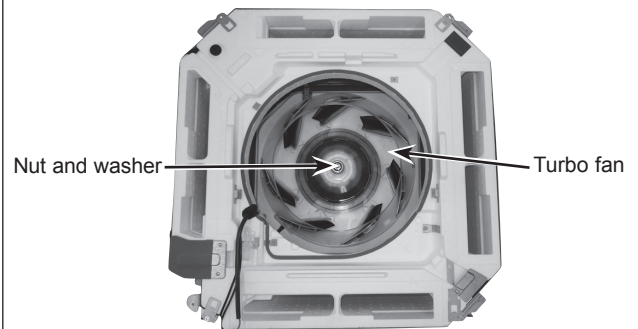

Photo 8



Turn this way to tighten. Turn this way to loosen.
(The same directions as the fan rotation.)

Rubber mount

Note: When re-attaching the motor mount, make sure that the thicker end faces the motor shaft.

Photo 9

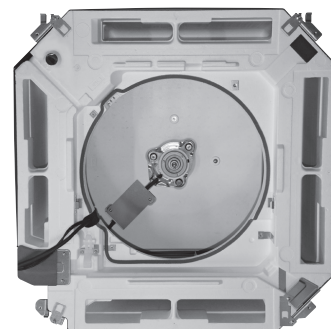

8. Removing the fan motor (MF)

- (1) Remove the turbo fan. (See Photo 8 and refer to procedure 7)
- (2) Remove the lead cover (tapping screw 4×10: 2 screws). (See Photo 10)
- (3) Loosen the 2 clamps.
- (4) Remove the 3 nuts and washers (M5).
- (5) Remove the fan motor.
- (6) Remove the 3 rubber mounts.

Photo 10

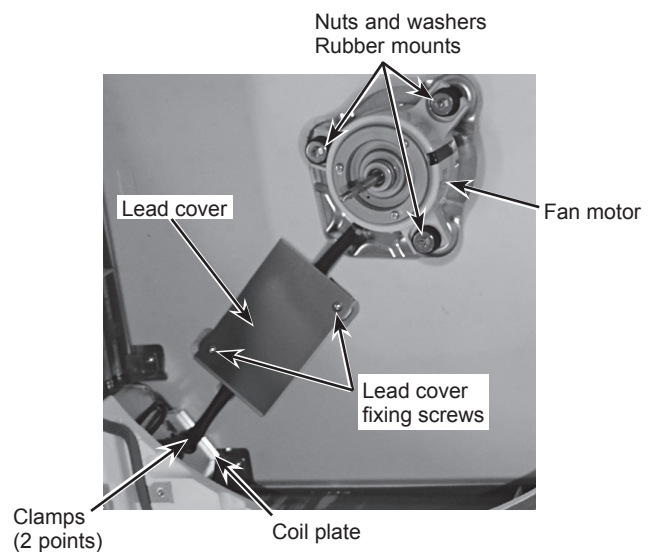
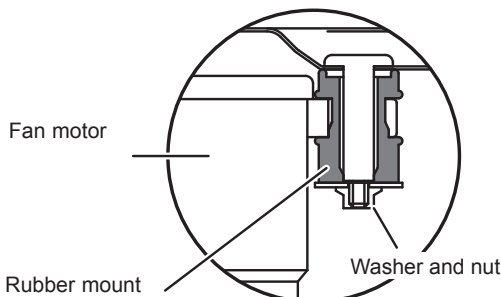

Figure 3: Partial cross section



Note: When re-attaching the motor mount, make sure that the thicker end faces the motor shaft.

OPERATING PROCEDURE

9. Removing the panel

- (1) Remove the electrical box fixing cover. (See Photo 1)
- (2) Disconnect the connector for vane motor (CNV: White). (Refer to procedure 5)
- (3) Loosen the 4 corner panel fixing screws (tapping screw 4×16). (See Figure 4)
- (4) Slide the corner panel to the direction of the arrow ①, and remove the corner panel. (See Figure 4)
- (5) Remove the 4 installation screws (M5×28). (See Photo 11)
- (6) Release the 2 temporary hanging hooks to remove the grille. (See Photo 12)

PHOTOS & ILLUSTRATIONS

Figure 4

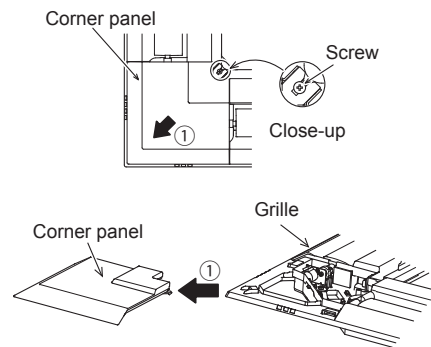

Photo 11

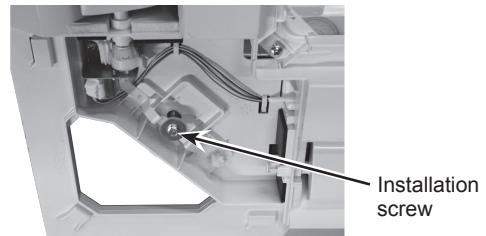
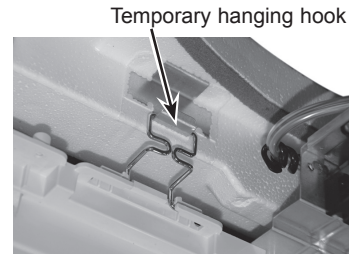

Photo 12



10. Removing the drain pan

- (1) Remove the electrical box. (See photo 3 and refer to procedure 6)
- (2) Remove the bell mouth (tapping screw 4×10 : 2 screws). (See Photo 6)
- (3) Remove the drain pan (screw M5×10: 4 screws).

Photo 13

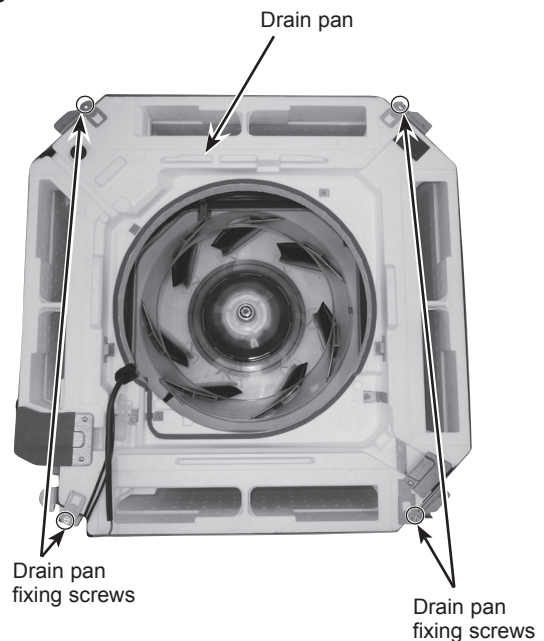

OPERATING PROCEDURE

11. Removing the pipe temperature/liquid thermistor (TH22) and condenser/evaporator temperature thermistor (TH23)

- (1) Remove the drain pan. (Refer to procedure 10) and loosen the 2 clamps of the coil plate. (See Photo 10)
- (2) Remove the coil plate (tapping screw 4×10: 2 screws).
- (3) Disconnect the pipe temperature/liquid thermistor (TH22) and condenser/evaporator temperature thermistor (TH23) from the holder.

PHOTOS & ILLUSTRATIONS

Photo 14



Pipe temperature detection thermistor/gas (TH23)

Pipe temperature detection thermistor/liquid (TH22)

12. Removing the drain pump (DP)

- (1) Remove the drain pan. (Refer to procedure 10)
- (2) Cut the hose band and remove the hose.
- (3) Loosen the clamp of the drain pump.
- (4) Remove the drain pump (tapping screw 4×10: 2 screws/2 hooks).
- (5) Cut the drain pump base and lead wire fixing band. (See Figure 5)
- (6) Remove the lead wire of the drain pump from the clamp of the drain pump base. (See Figure 5)
- (7) Remove the drain pump (tapping screw: 3 screws). (See Figure 6)

Photo 15

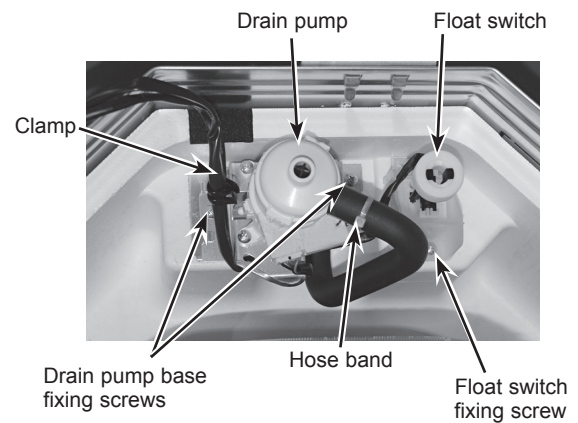

Figure 6

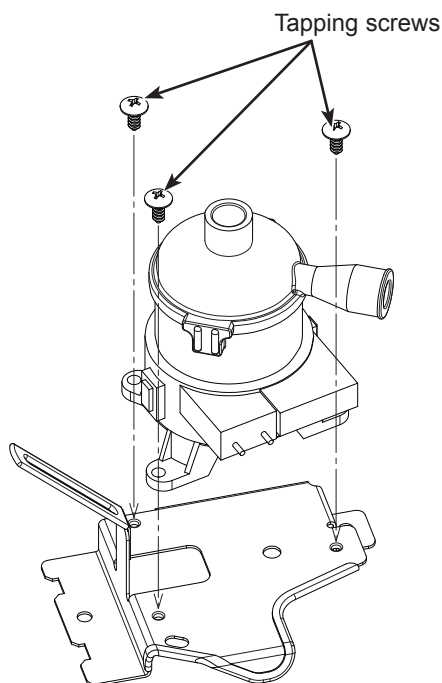
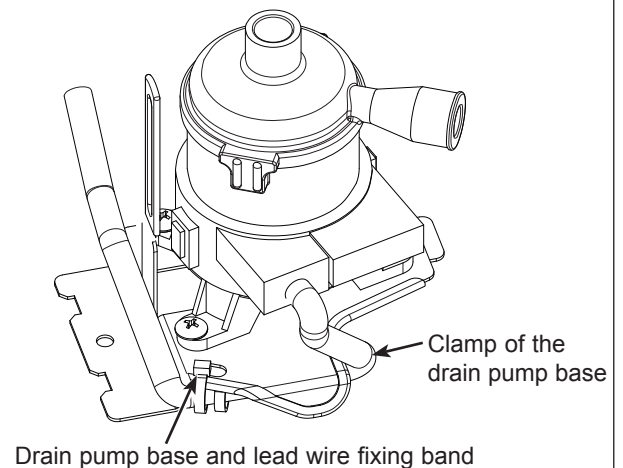

Figure 5



OPERATING PROCEDURE

13. Removing the float switch (FS)

- (1) Remove the drain pan. (Refer to procedure 10)
- (2) Loosen the clamp of the drain pump. (See Photo 15)
- (3) Remove the float switch (tapping screw 4×10: 1 screw/1 hook). (See Photo 15)
- (4) Remove the float switch base and the lead wire fixing band. (See Photo 16)
- (5) Remove the lead wire from the U shaped portion of the float switch base. (See Photo 16)
- (6) Slide the float switch towards the arrow to remove from the float switch base.

PHOTOS

Photo 16

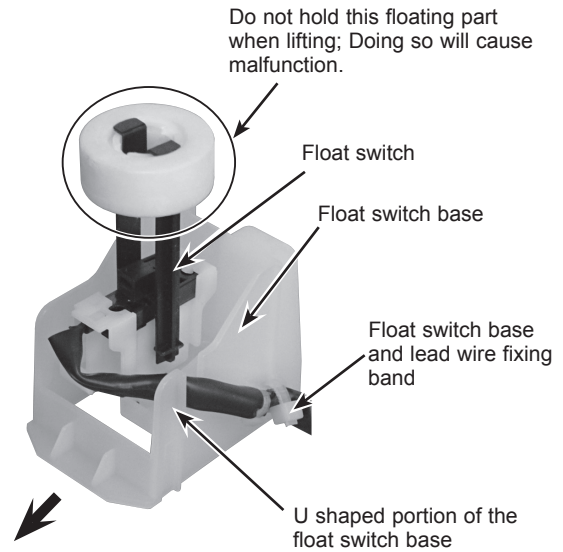

14. Removing the heat exchanger

- (1) Remove the drain pan. (Refer to procedure 10)
- (2) Remove the piping cover (tapping screw 4×10: 3 screws).
- (3) Remove the coil plate (tapping screw 4×10: 2 screws).
- (4) Remove the heat exchanger fixing screws (tapping screw 4×10: 2 screws).
- (5) Remove the coil support (tapping screw 4×10: 1 screw each)
 - P20–80: 1 coil support (See photo 17)
 - P100, 125: 3 coil supports (See photo 18)
- (6) Remove the heat exchanger.

Photo 18

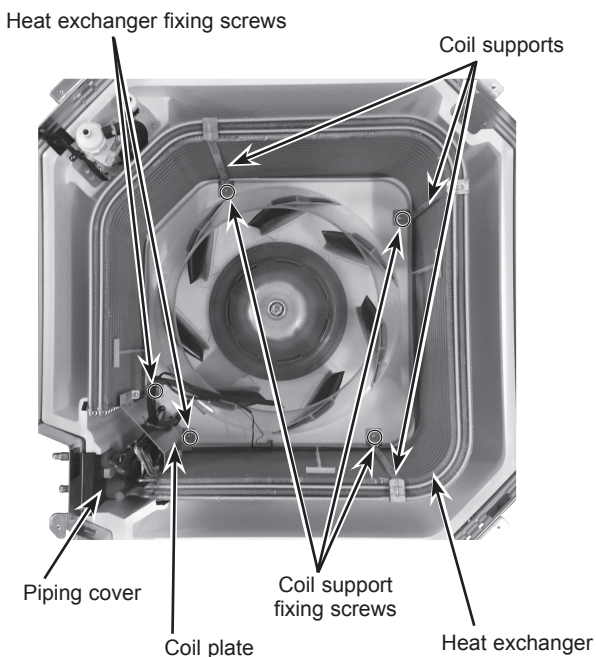
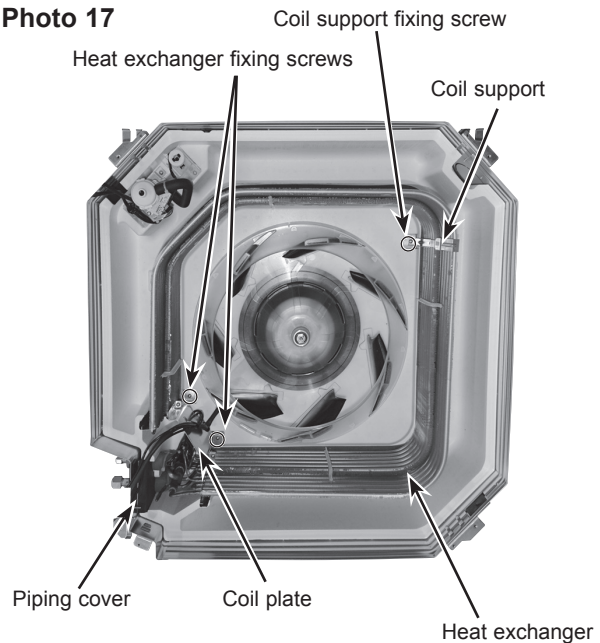

Photo 17



CITY MULTI

mitsubishi electric corporation

HEAD OFFICE : TOKYO BUILDING, 2-7-3, MARUNOUCHI, CHIYODA-KU, TOKYO 100-8310, JAPAN
