

# **TECHNICAL & SERVICE MANUAL**

---

Model name

**PEFY-WP20VMA-E  
PEFY-WP25VMA-E  
PEFY-WP32VMA-E  
PEFY-WP40VMA-E  
PEFY-WP50VMA-E**

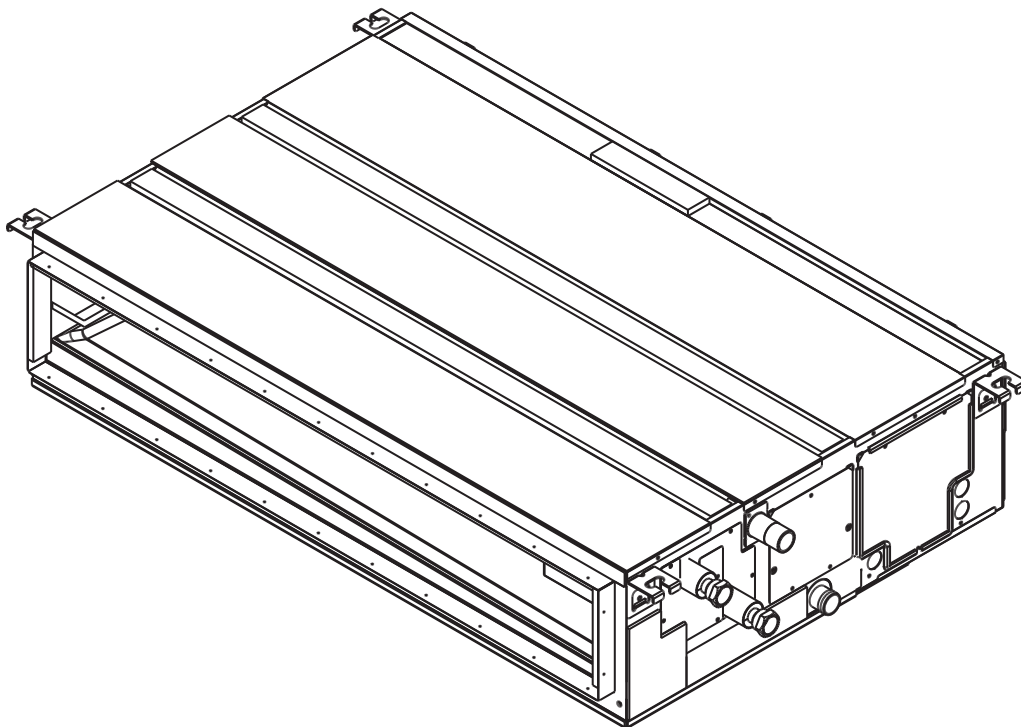

# **CITY MULTI**



# Safety Precautions

## Read before installation and performing electrical work

- Thoroughly read the following safety precautions prior to installation.
- Observe these safety precautions for your safety.
- This equipment may have adverse effects on the equipment on the same power supply system.
- Contact the local power authority before connecting to the system.

### Symbol explanations



#### WARNING

This symbol indicates that failure to follow the instructions exactly as stated poses the risk of serious injury or death.



#### CAUTION

This symbol indicates that failure to follow the instructions exactly as stated poses the risk of serious injury or damage to the unit.



Indicates an action that must be avoided.



Indicates important instructions.



Indicates a parts that requires grounding.



Indicates that caution must be taken with rotating parts. (This symbol is on the main unit label.) <Color: Yellow>



Indicates that the parts that are marked with this symbol pose a risk of electric shock. (This symbol is on the main unit label.) <Color: Yellow>



#### WARNING

Carefully read the labels affixed to the main unit.



#### WARNING

- Do not use refrigerant other than the type indicated in the manuals provided with the unit and on the nameplate.  
Doing so may cause the unit or pipes to burst, or result in explosion or fire during use, during repair, or at the time of disposal of the unit.  
It may also be in violation of applicable laws.  
MITSUBISHI ELECTRIC CORPORATION cannot be held responsible for malfunctions or accidents resulting from the use of the wrong type of refrigerant.
- Ask your dealer or a qualified technician to install the unit.  
Improper installation by the user may result in water leakage, electric shock, or fire.
- Properly install the unit on a surface that can withstand its weight.  
Unit installed on an unstable surface may fall and cause injury.
- Only use specified cables. Securely connect each cable so that the terminals do not carry the weight of the cable.  
Improperly connected cables may produce heat and start a fire.

- Take appropriate safety measures against wind gusts and earthquakes to prevent the unit from toppling over.  
Improper installation may cause the unit to topple over and cause injury or damage to the unit.
- Only use accessories (i.e., air cleaners, humidifiers, electric heaters) recommended by Mitsubishi Electric.
- Do not make any modifications or alterations to the unit.  
Consult your dealer for repair.  
Improper repair may result in water leakage, electric shock, or fire.
- Do not touch the heat exchanger fins with bare hands.  
The fins are sharp and pose a risk of cuts.
- Properly install the unit according to the instructions in the Installation Manual.  
Improper installation may result in water leakage, electric shock, or fire.

## WARNING

Have all electrical work performed by an authorized electrician according to the local regulations and the instructions in this manual. Use a dedicated circuit.

Insufficient power supply capacity or improper installation of the unit may result in malfunctions of the unit, electric shock, or fire.

Keep electrical parts away from water.

Wet electrical parts pose a risk of electric shock, smoke, or fire.

Securely attach the control box cover.

If the cover is not installed properly, dust or water may infiltrate and pose a risk of electric shock, smoke, or fire.

Only use the type of water that is indicated on the unit when installing or relocating the unit.

Infiltration of any other types of refrigerant or air into the unit may adversely affect the refrigerant cycle and may cause the pipes to burst or explode.

Consult your dealer or a qualified technician when moving or reinstalling the unit.

Improper installation may result in water leakage, electric shock, or fire.

After completing the service work, check for water leakage.

To avoid water damage to the furnishings, check for water leak at the completion of all work.

Do not try to defeat the safety features of the unit.

Forced operation of the pressure switch or the temperature switch by defeating the safety features for these devices, or the use of accessories other than the ones that are recommended by Mitsubishi Electric may result in smoke, fire, or explosion.

Consult your dealer for proper disposal method.

## Precautions for handling units for use with water

### CAUTION

Do not use the existing water piping.

Store the piping materials indoors, and keep both ends of the pipes sealed until immediately before installation. Keep the joints wrapped in plastic bags. If dust or dirt enters the water circuit, it may damage the heat exchanger and cause water leakage.

Only use water.

Only use clean water as a refrigerant. The use of water outside the specification may damage the refrigerant circuit.

# CONTENTS

---

## I Features

[1] Features.....	1
-------------------	---

## II Components and Functions

[1] Components and Functions.....	2
-----------------------------------	---

## III Specifications

[1] Specifications.....	4
1.Specifications.....	4
2.Electrical component specifications.....	6

## IV Outlines and Dimensions

[1] Outlines and Dimensions.....	7
----------------------------------	---

## V Wiring Diagram

[1] Wiring Diagram.....	8
-------------------------	---

## VI Refrigerant System Diagram

[1] Refrigerant system diagram.....	10
-------------------------------------	----

## VII Troubleshooting

[1] Troubleshooting.....	11
1.Check methods.....	11
2.DC fan motor (fan motor/indoor control board).....	13
3.Address switch setting.....	14
4.Voltage test points on the control board.....	15
5.Dipswitch setting (Factory setting).....	16

## VIII Disassembly Procedure

[1] Disassembly Procedure.....	19
1.Control box.....	19
2.Thermistor (Intake air).....	20
3.Drainpan.....	21
4.Thermistor (Water outlet) (Water inlet).....	22
5.Fan and fan motor.....	23
6.Heat exchanger.....	24



**[1] Features**

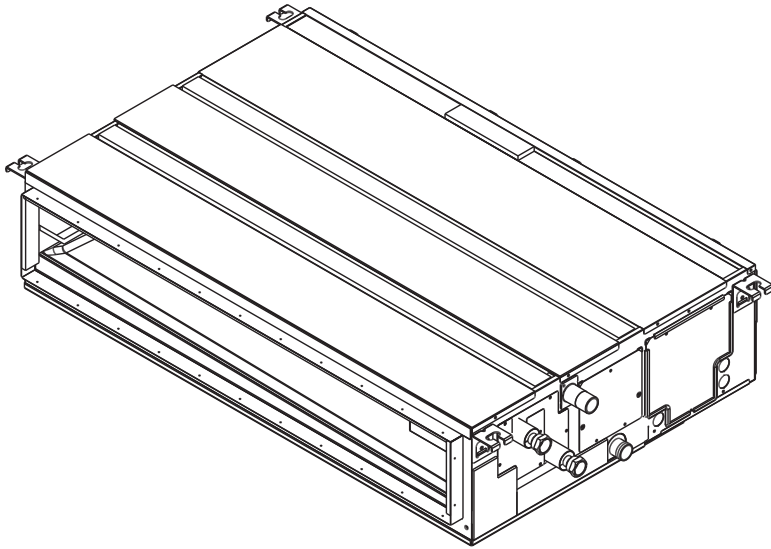

Model	Cooling capacity/Heating capacity
	kW
PEFY-WP20VMA-E	2.2/2.5
PEFY-WP25VMA-E	2.8/3.2
PEFY-WP32VMA-E	3.6/4.0
PEFY-WP40VMA-E	4.5/5.0
PEFY-WP50VMA-E	5.6/6.3

## [1] Components and Functions

### 1. Indoor (Main) Unit

(1) In case of rear inlet

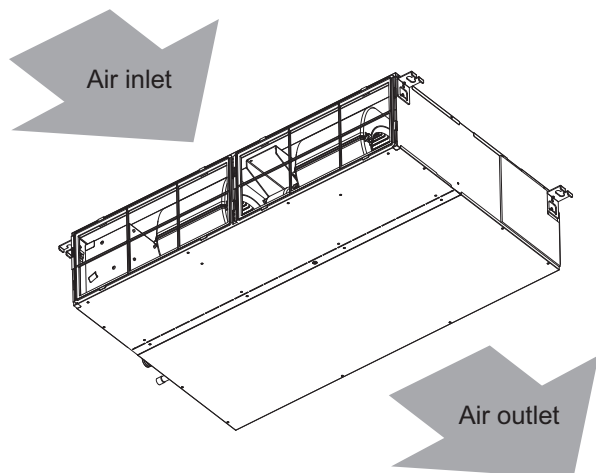

(2) In case of bottom inlet

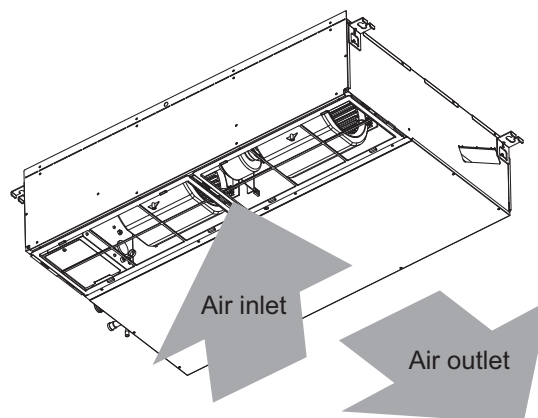

### 2. Remote Controller

[PAR-21MAA]

Once the operation mode is selected, the unit will remain in the selected mode until changed.

#### (1) Remote Controller Buttons

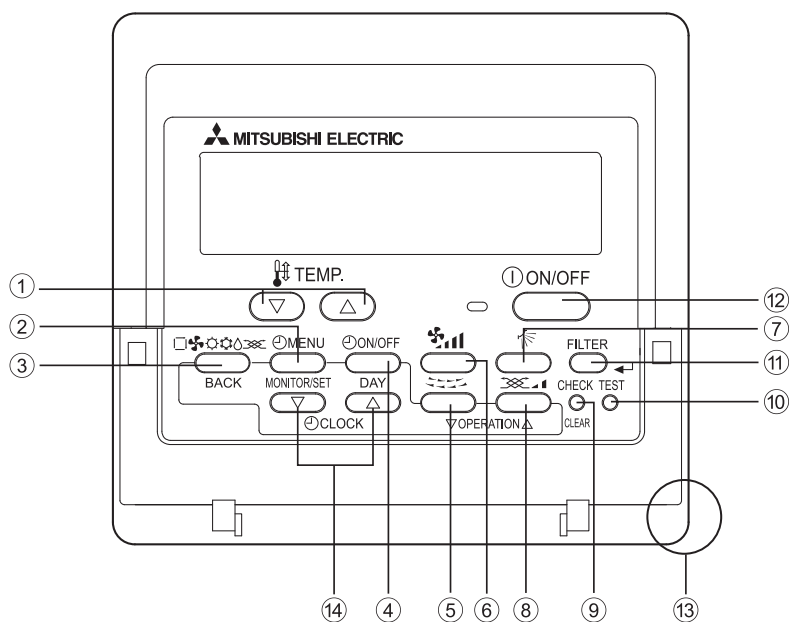

- |                            |   |
|----------------------------|---|
| 1 [Set Temperature] Button | 7 [Vane Control] Button                 |
| 2 [Timer Menu] Button      | 8 [Ventilation] Button                  |
| [Monitor/Set] Button       | [Operation] Button                      |
| 3 [Mode] Button            | 9 [Check/Clear] Button                  |
| [Back] Button              | 10 [Test Run] Button                    |
| 4 [Timer On/Off] Button    | 11 [Filter] Button                      |
| [Set Day] Button           | [↕] Button                              |
| 5 [Louver] Button          | 12 [ON/OFF] Button                      |
| [Operation] Button         | 13 Position of built-in room thermistor |
| 6 [Fan Speed] Button       | 14 [Set Time] Button                    |

•Keep the remote controller out of direct sunlight to ensure accurate measurement of room temperature.

•The thermistor at the lower right-hand section of the remote controller must be free from obstructions to ensure accurate measurement of room temperature.



(2) Remote Controller Display

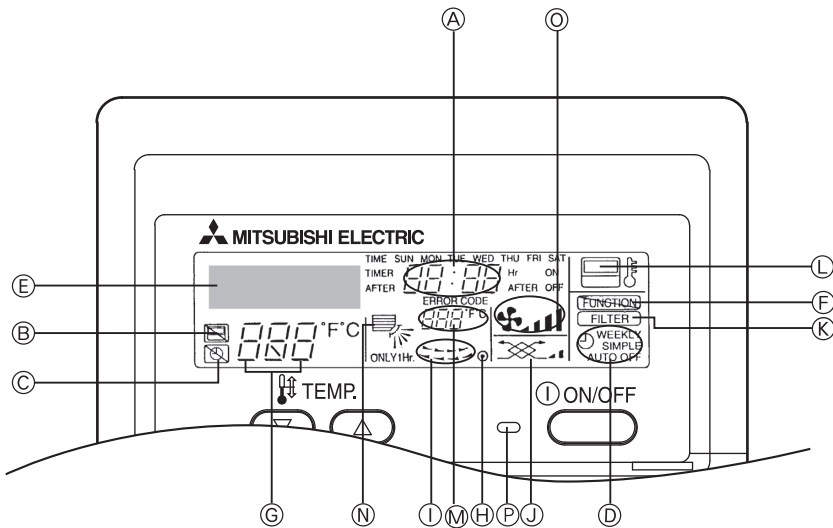

- |   |   |   |                  |
|---|---|---|------------------|
| A | Current time/Timer time                                 | I | Louver swing     |
| B | Centralized control indicator                           | J | Ventilation      |
| C | Timer OFF indicator                                     | K | Filter sign      |
| D | Timer mode indicator                                    | L | Sensor position  |
| E | Operation mode display:  COOL,  DRY,  AUTO,  FAN,  HEAT | M | Room temperature |
| F | Function mode indicator                                 | N | Vane setting     |
| G | Preset temperature                                      | O | Fan speed        |
| H | Power indicator   | P | Operation lamp   |

**[1] Specifications**

**1. Specifications**

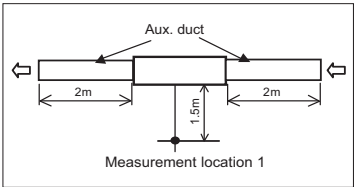
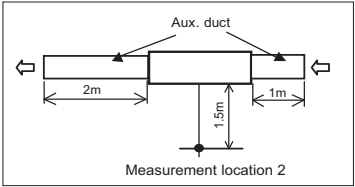
Model			PEFY-WP20VMA-E	PEFY-WP25VMA-E		
Power supply	Voltage	V	1-phase 220-230-240			
	Frequency	Hz	50/60			
Cooling capacity *1		kW	2.2	2.8		
Heating capacity *1		kW	2.5	3.2		
Power consumption	Cooling	kW	0.07	0.09		
	Heating	kW	0.05	0.07		
Current consumption	Cooling	kW	0.55	0.64		
	Heating	kW	0.44	0.53		
External finish			Galvanized			
Dimensions	Height	mm	250			
	Width	mm	700	900		
	Depth	mm	732			
Net weight		kg	21	26		
Heat exchanger			Cross fin(Aluminium fin and copper tube)			
Fan	Type		Sirocco fan x 1			
	Airflow rate (Low-Mid-High)	m <sup>3</sup> /min	7.5-9.0-10.5	10.0-12.0-14.0		
	External static pressure	Pa	35/50/70/100/150			
Motor	Output	kW	0.085			
Air filter			PP Honeycomb fabric (washable)			
Diameter of water pipe	Inlet	in	Rc3/4 screw			
	Outlet	in	Rc3/4 screw			
Drain pipe dimensions		mm[in.]	O.D. 32[1-1/4]			
Operating noise(Low-Mid-High)	 <p>Measurement location 1</p> <p>* Measured in anechoic room.</p>		35Pa	dB (A)	23-25-28	23-26-29
			50Pa		23-26-29	23-27-30
			70Pa		24-27-30	24-28-31
			100Pa		25-28-32	26-29-33
			150Pa		28-32-36	29-33-37
	 <p>Measurement location 2</p> <p>* Measured in anechoic room.</p>		35Pa		28-30-34	28-30-34
			50Pa		28-30-34	28-30-34
			70Pa		29-32-36	29-32-36
			100Pa		29-33-37	29-33-37
			150Pa		31-35-40	32-36-40

\*1 <Cooling> Indoor temperature: 27°CDB/19°CWB (81°FDB/66°FWB) Outdoor temperature: 35°CDB (95°FDB)  
 <Heating> Indoor temperature: 20°CDB (68°FWB) Outdoor temperature: 7°CDB/6°CWB (45°FDB/43°FWB)

[ III Specifications ]

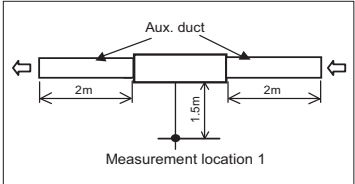
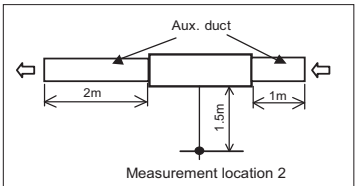
Model			PEFY-WP32VMA-E	PEFY-WP40VMA-E	PEFY-WP50VMA-E	
Power supply	Voltage	V	1-phase 220-230-240			
	Frequency	Hz	50/60			
Cooling capacity *1		kW	3.6	4.5	5.6	
Heating capacity *1		kW	4.0	5.0	6.3	
Power consumption	Cooling	kW	0.11	0.14	0.14	
	Heating	kW	0.09	0.12	0.12	
Current consumption	Cooling	kW	0.74	1.15	1.15	
	Heating	kW	0.63	1.04	1.04	
External finish			Galvanized			
Dimensions	Height	mm	250			
	Width	mm	900	1100		
	Depth	mm	732			
Net weight		kg	26	31		
Heat exchanger			Cross fin(Aluminium fin and copper tube)			
Fan	Type		Sirocco fan x 1	Sirocco fan x 2		
	Airflow rate (Low-Mid-High)	m <sup>3</sup> /min	12.0-14.5-17.0	14.5-18.0-21.0	14.5-18.0-21.0	
	External static pressure	Pa	35/50/70/100/150			
Motor	Output	kW	0.085	0.121		
Air filter			PP Honeycomb fabric (washable)			
Diameter of water pipe	Inlet	in	Rc3/4 screw			
	Outlet	in	Rc3/4 screw			
Drain pipe dimensions		mm[in.]	O.D. 32[1-1/4]			
Operating noise(Low-Mid-High)		35Pa	dB (A)	24-28-31	26-29-33	26-29-33
 <p>Measurement location 1</p> <p>* Measured in anechoic room.</p>		50Pa		25-29-32	26-29-34	26-29-34
		70Pa		26-30-33	26-30-35	26-30-35
		100Pa		27-31-34	29-33-37	29-33-37
		150Pa		29-34-38	32-37-41	32-37-41
		35Pa		28-31-35	30-33-37	30-33-37
 <p>Measurement location 2</p> <p>* Measured in anechoic room.</p>		50Pa		28-32-35	30-34-38	30-34-38
		70Pa		29-33-37	31-36-39	31-36-39
		100Pa		30-34-38	33-37-41	33-37-41
		150Pa		32-37-41	36-41-44	36-41-44
		35Pa		28-31-35	30-33-37	30-33-37

\*1 <Cooling> Indoor temperature: 27°CDB/19°CWB (81°FDB/66°FWB) Outdoor temperature: 35°CDB (95°FDB)  
 <Heating> Indoor temperature: 20°CDB (68°FWB) Outdoor temperature: 7°CDB/6°CWB (45°FDB/43°FWB)

## 2. Electrical component specifications

Component	Sym- bol	PEFY-WP20VMA-E
Room temperature thermistor	TH21	Resistance 0°C/15kΩ, 10°C/9.6kΩ, 20°C/6.3kΩ, 25°C/5.4kΩ, 30°C/4.3kΩ, 40°C/3.0kΩ
Water inlet pipe thermistor	TH22	Resistance 0°C/15kΩ, 10°C/9.6kΩ, 20°C/6.3kΩ, 25°C/5.4kΩ, 30°C/4.3kΩ, 40°C/3.0kΩ
Water outlet pipe thermistor	TH23	Resistance 0°C/15kΩ, 10°C/9.6kΩ, 20°C/6.3kΩ, 25°C/5.4kΩ, 30°C/4.3kΩ, 40°C/3.0kΩ
Fuse	FUSE	250V 6.3A
Fan motor		8-pole, Output 85W SIC-70CW-D885-1
Power supply terminal block	TB2	(L, N, ⊕) 250V 20A
Transmission terminal block	TB5 TB15	(1, 2) 250V 15A, (M1, M2, S) 250V 20A
Drain float switch	DS	Open/short detection Initial contact resistance 500 mΩ or less

Component	Sym- bol	PEFY- WP25VMA-E	PEFY- WP32VMA-E	PEFY- WP40VMA-E	PEFY- WP50VMA-E
Room temperature thermistor	TH21	Resistance 0°C/15kΩ, 10°C/9.6kΩ, 20°C/6.3kΩ, 25°C/5.4kΩ, 30°C/4.3kΩ, 40°C/3.0kΩ			
Water inlet pipe thermistor	TH22	Resistance 0°C/15kΩ, 10°C/9.6kΩ, 20°C/6.3kΩ, 25°C/5.4kΩ, 30°C/4.3kΩ, 40°C/3.0kΩ			
Water outlet pipe thermistor	TH23	Resistance 0°C/15kΩ, 10°C/9.6kΩ, 20°C/6.3kΩ, 25°C/5.4kΩ, 30°C/4.3kΩ, 40°C/3.0kΩ			
Fuse	FUSE	250V 6.3A			
Fan motor		8-pole, Output 85W SIC-70CW-D885-2		8-pole, Output 121W SIC-70CW-D8121-1	
Power supply terminal block	TB2	(L, N, ⊕) 250V 20A			
Transmission terminal block	TB5 TB15	(1, 2) 250V 15A, (M1, M2, S) 250V 20A			
Drain float switch	DS	Open/short detection Initial contact resistance 500 mΩ or less			

**[1] Outlines and Dimensions**

1. PEFY-WP20, 25, 32, 40, 50VMA-E

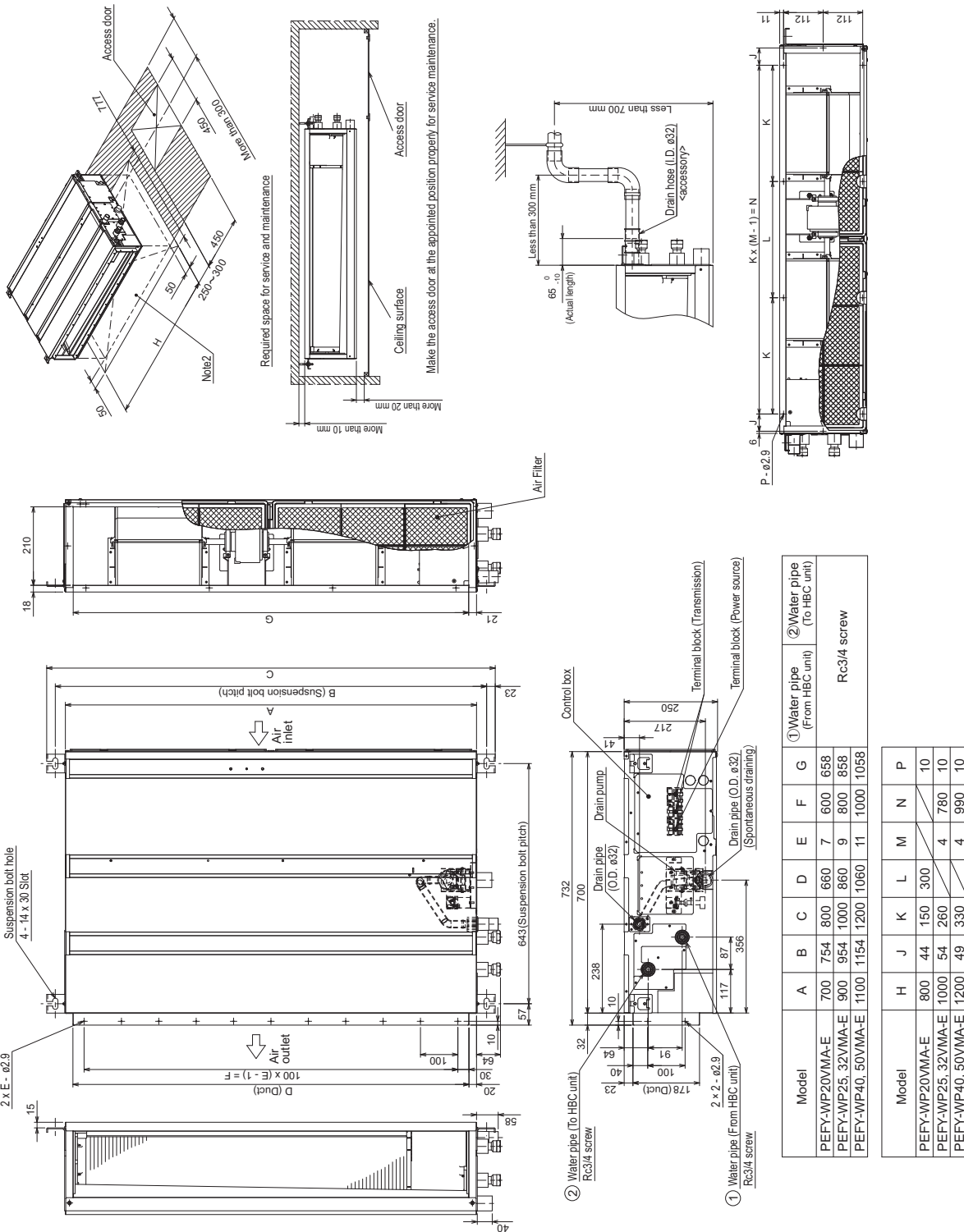

- (A) Space required for service and maintenance.
- (B) Provide an access door for maintenance at the bottom.

- Note
- 1 Use M10 suspension bolts. (not supplied)
  - 2 Provide an access door for maintenance at the bottom.
  - 3 The dimensions in the table are those of the PEFY-WP40, 50VMA-E models, which have 2 fans. The PEFY-WP20, 25, 32VMA-E model have 1 fans.
  - 4 To connect an intake duct, uninstall the air filter on the unit, and install a locally procured air filter on the intake duct on the intake side.

# [1] Wiring Diagram

1. PEFY-WP20, 25, 32, 40, 50VMA-E

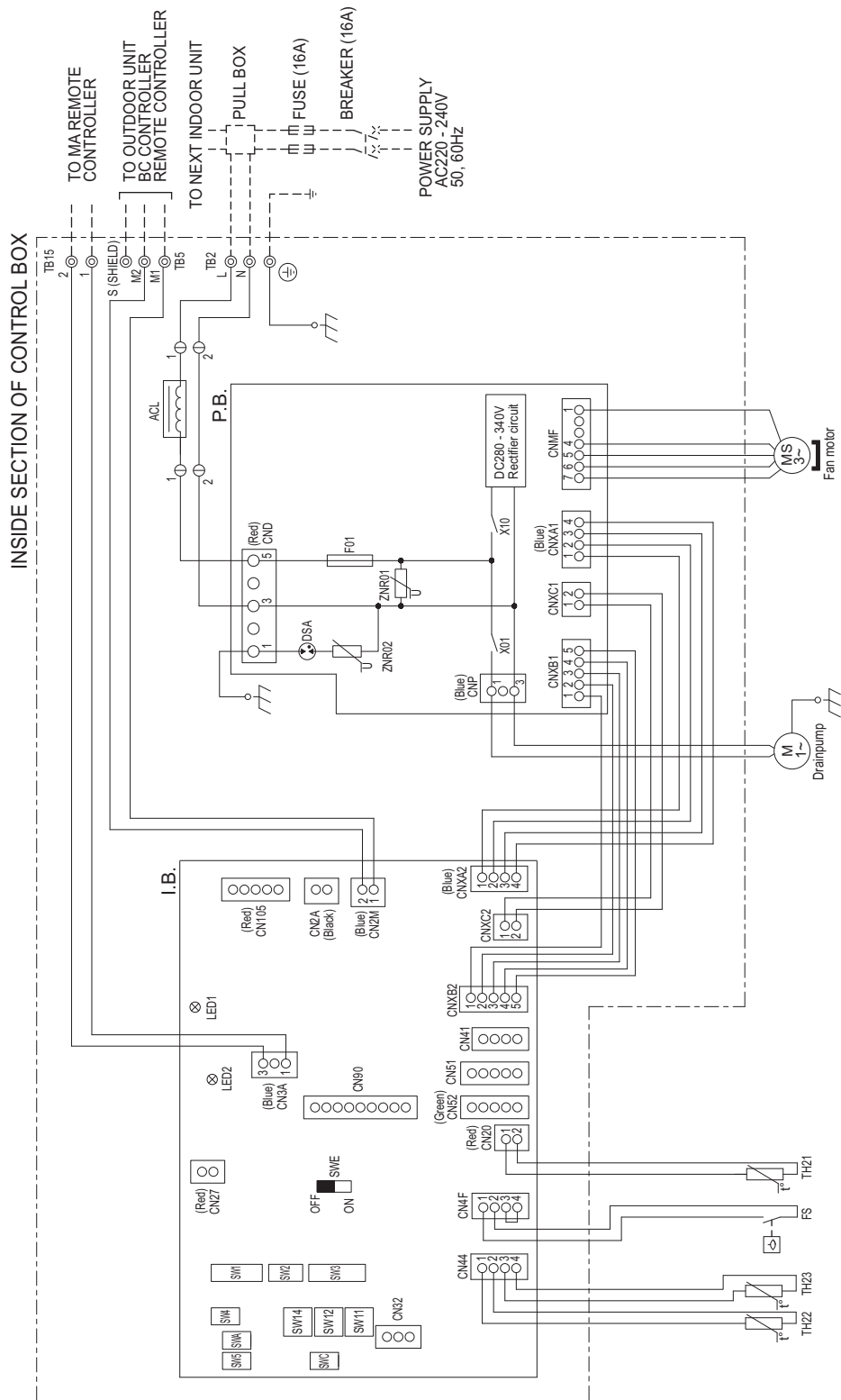
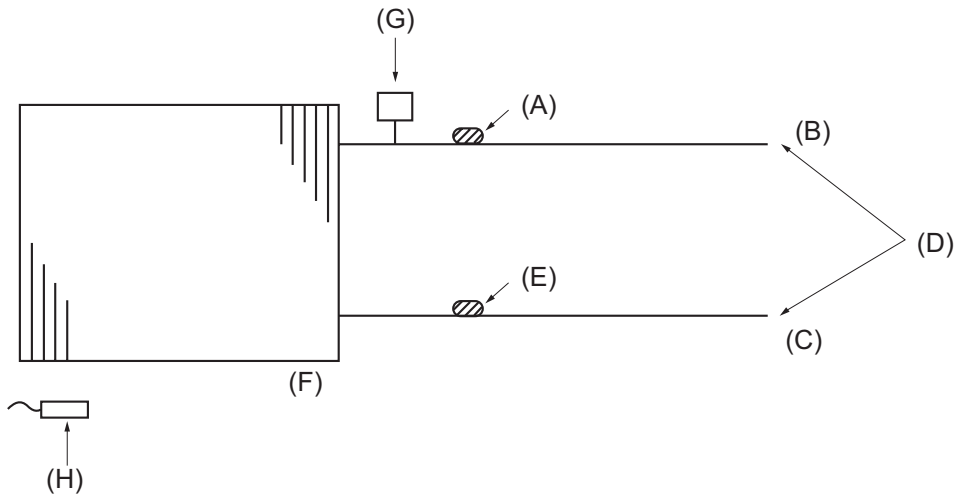

Table.1 SYMBOL EXPLANATION

SYM-BOL	NAME	SYM-BOL	NAME	SYM-BOL	NAME
I.B.	Indoor controller board	CN32	Connector (Remote switch)	SW2 (I.B.)	Switch (for capacity code)
P.B.	Power supply board	CN41	Connector (HA terminal-A)	SW3 (I.B.)	Switch (for mode selection)
TB2	Power source terminal block	CN51	Connector (Centrally control)	SW4 (I.B.)	Switch (for model selection)
TB5	Transmission terminal block	CN52	Connector (Remote indication)	SW5 (I.B.)	Switch (for mode selection)
TB15	Transmission terminal block	CN90	Connector (Wireless)	SWE (I.B.)	Connector (emergency operation)
F01	Fuse AC 250V 6.3A	CN105	Connector (IT terminal)	SW11 (I.B.)	Switch (1s digit address set)
ZNR01, 02	Varistor	CN2A	Connector (0-10V Analog input)	SW12 (I.B.)	Switch (10ths digit address set)
DSA	Arrester	FS	Float switch	SW14 (I.B.)	Switch (BRANCH No.)
X01	Aux. relay	TH21	Thermistor (inlet air temp. detection)	SWA (I.B.)	Switch (for static pressure selection)
X10	Aux. relay	TH22	Thermistor (piping temp. detection / water inlet)	SWC (I.B.)	Switch (for static pressure selection)
ACL	AC reactor (Power factor improvement)	TH23	Thermistor (piping temp. detection / water outlet)		
CN27	Connector (Damper)	SW1 (I.B.)	Switch (for mode selection)		

- Note 1 Wiring to TB2, TB5, and TB15 indicated by the double-dashed lines is on-site work.  
 2 ⊙ terminal block, ⊖ connector.

**[1] Refrigerant system diagram**



- (A) Water outlet thermistor TH23
- (B) Water outlet
- (C) Water inlet
- (D) Screw connections
- (E) Water inlet thermistor TH22
- (F) Heat exchanger
- (G) Manual air purge valve
- (H) Room temperature thermistor TH21

Capacity	PEFY-WP20, 25, 32, 40, 50VMA-E
Water outlet	Rc3/4 screw
Water inlet	Rc3/4 screw



## [1] Troubleshooting

### 1. Check methods

1. Component and check points

(1) Thermistor

- Room temperature thermistor (TH21)
- Water inlet thermistor (TH22)
- Water outlet thermistor (TH23)

Disconnect the connector and measure the resistance between terminals with a volt meter.  
(Ambient temperature 10°C - 30°C)

Normal	Abnormal
4.3kΩ - 9.6kΩ	Open or short

(Refer to the thermistor characteristic graph below.)

1) Thermistor characteristic graph

**Low-temperature thermistor**

- Room temperature thermistor (TH21)
- Water inlet pipe thermistor (TH22)
- Water outlet thermistor (TH23)
- Drain sensor (DS)

- Thermistor  $R_0 = 15\text{ k}\Omega \pm 3\%$
- Multiplier of B =  $3480\text{ k}\Omega \pm 2\%$

$$R_t = 15 \exp \left\{ 3480 \left( \frac{1}{273+t} - \frac{1}{273} \right) \right\}$$

- 0°C 15kΩ
- 10°C 9.6kΩ
- 20°C 6.3kΩ
- 25°C 5.2kΩ
- 30°C 4.3kΩ
- 40°C 3.0kΩ

(A) Temperature (°C)

(B) Resistance (kΩ)

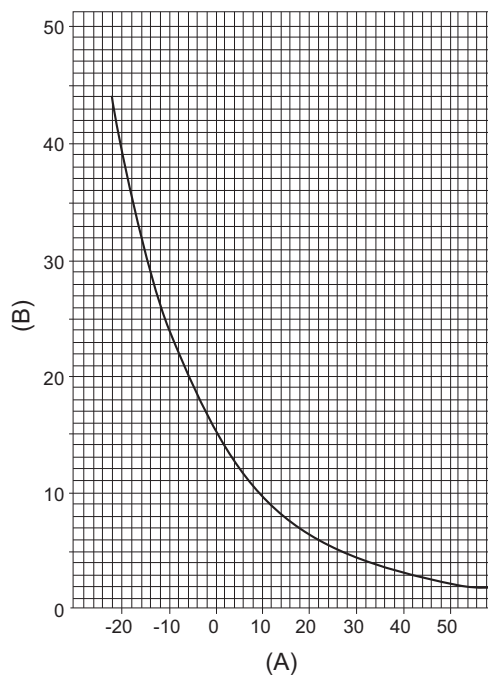

(2) Fan motor (CNMF)

Refer to the page on "DC fan motor (fan motor/indoor control board)."

(3) Drain-up mechanism

Measure the resistance between the terminals with a tester.  
(coil temperature 20°C)

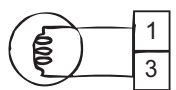
	Normal	Abnormal
	340 Ω	Open or short

(4) Drain float switch (CN4F)

Disconnect the connector, and measure the resistance between terminals with a volt meter.

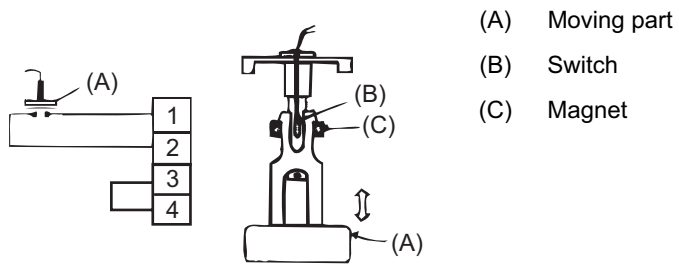

Position of the moving part	Normal	Abnormal
Up	Short	(any position but short)
Down	Open	(any position but open)

## 2. DC fan motor (fan motor/indoor control board)

### 1. CAUTION

- A high voltage is applied to the connector for connection to the fan motor (CNMF).
- Do not unplug the connector CNMF with the unit energized to avoid damage to the indoor control board and fan motor.

### 2. Troubleshooting

- Symptom: Indoor unit fan does not run.

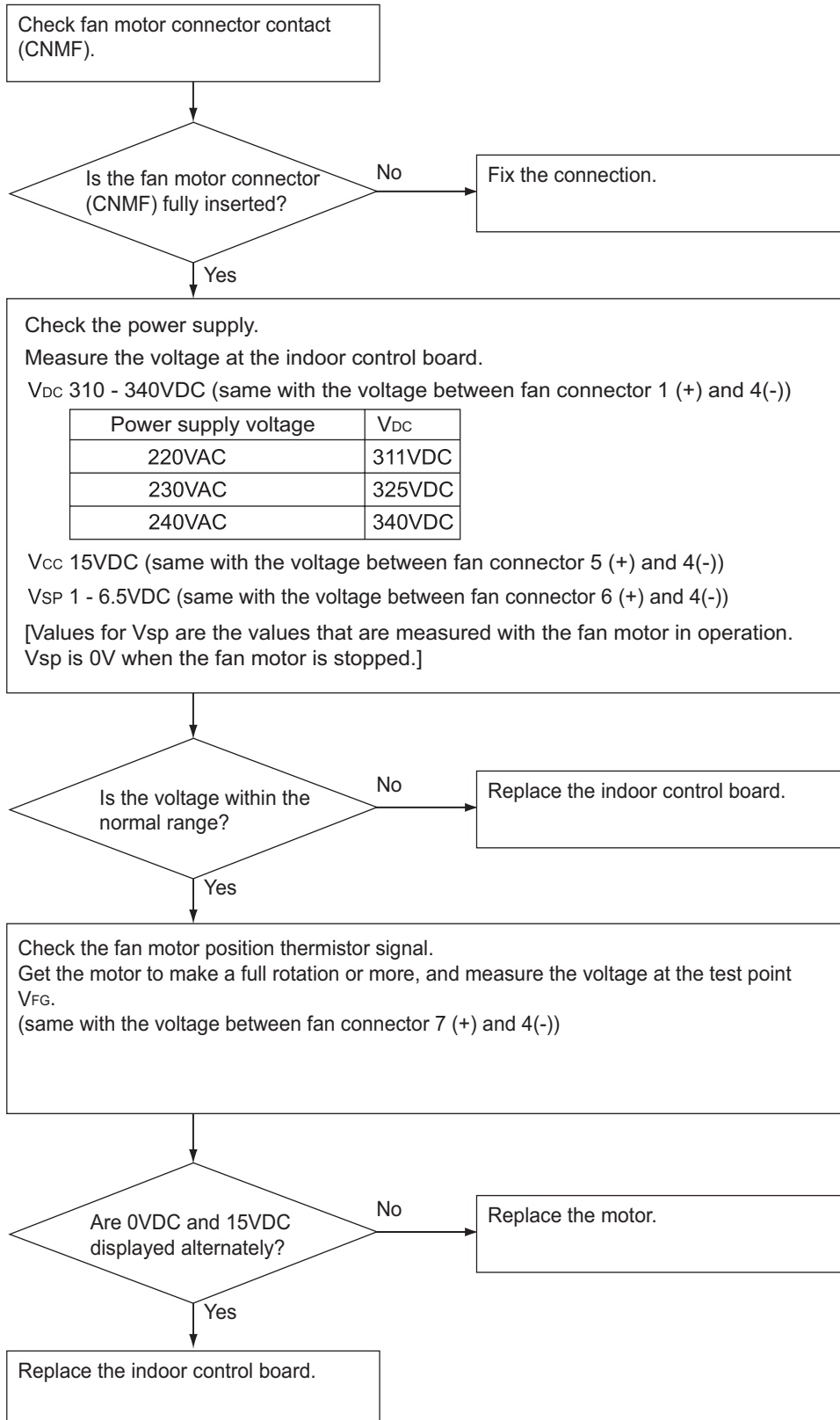

### 3. Address switch setting

Make sure that power to the unit is turned off.

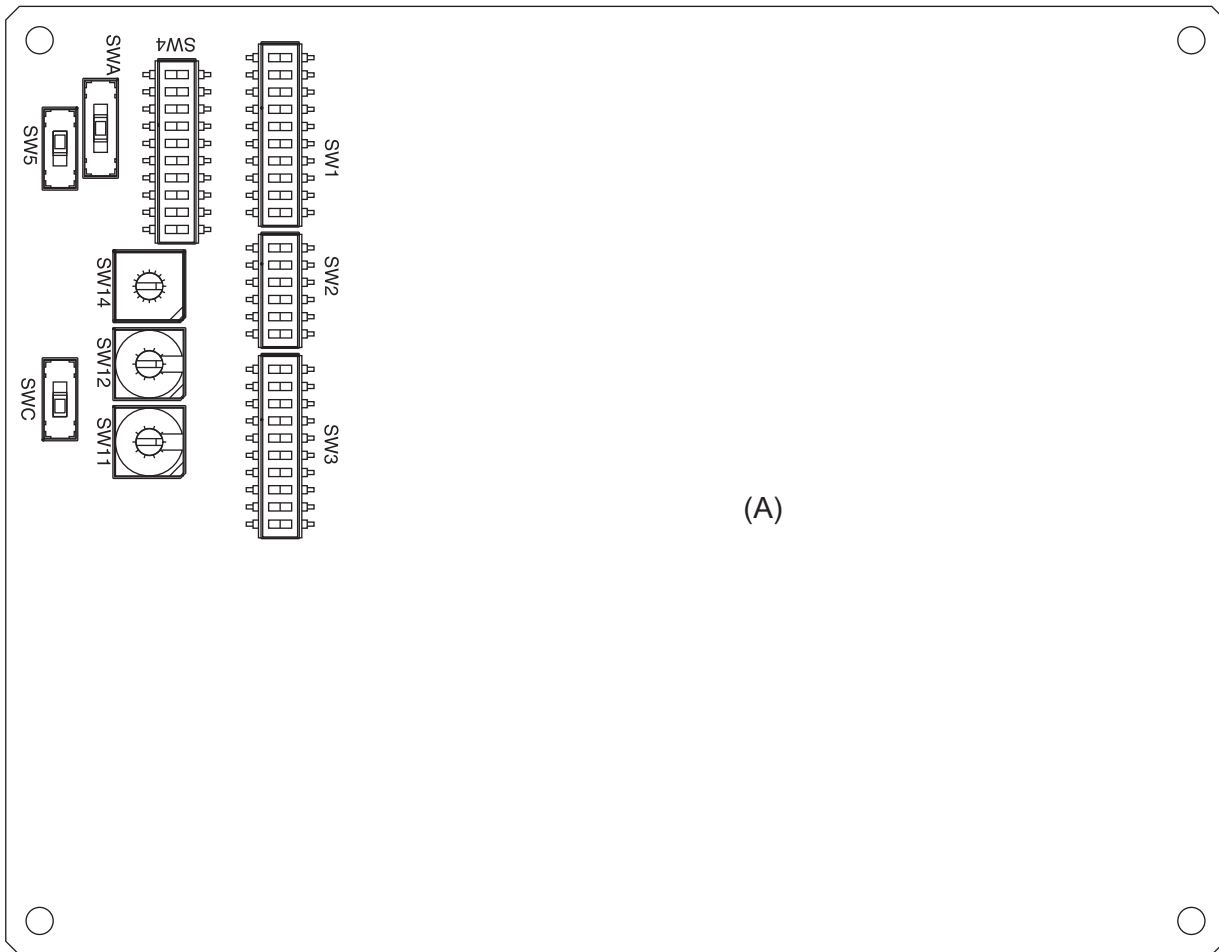

(A)



(B)

- (A) Indoor unit control board
- (B) Factory setting (all models)

1. When using an ME remote controller, set the address with the rotary switches (SW11, SW12).  
 •Address setting is not required when the unit remote controller is used.  
**On-site address setting is required for the indoor units to run.**
2. Address settings vary in different systems.  
 Refer to the section on address setting in the outdoor unit installation manual.
3. Address is set with a combination of SW12 (10's digit) and SW11 (1's digit).  
 To set the address to "3," set SW12 to "0" and SW11 to "3."  
 To set the address to "25," set SW 12 to "2" and SW 11 to "5."

### 4. Voltage test points on the control board

#### 1. PEFY-WP20, 25, 32, 40, 50VMA-E

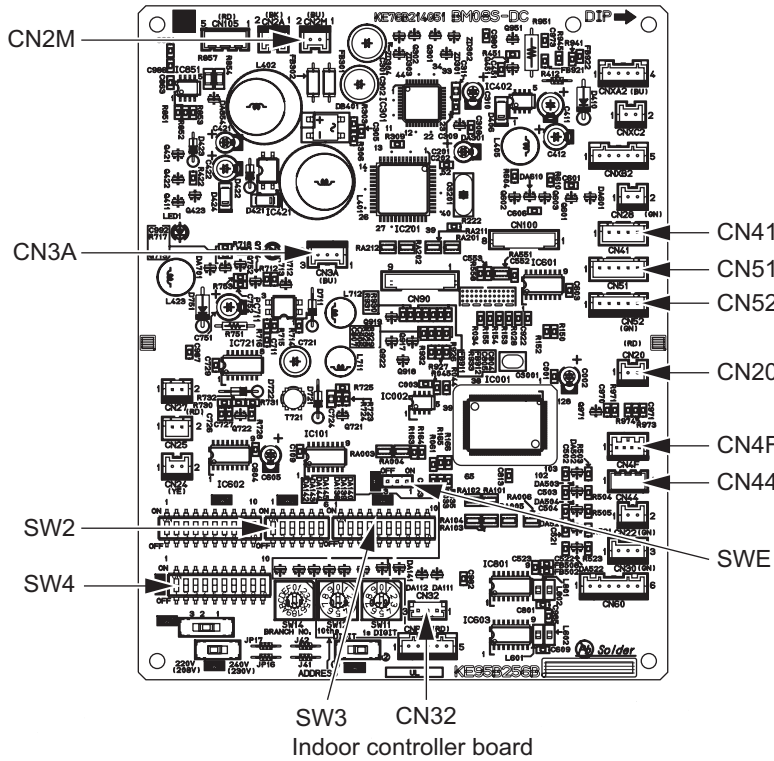

Indoor controller board

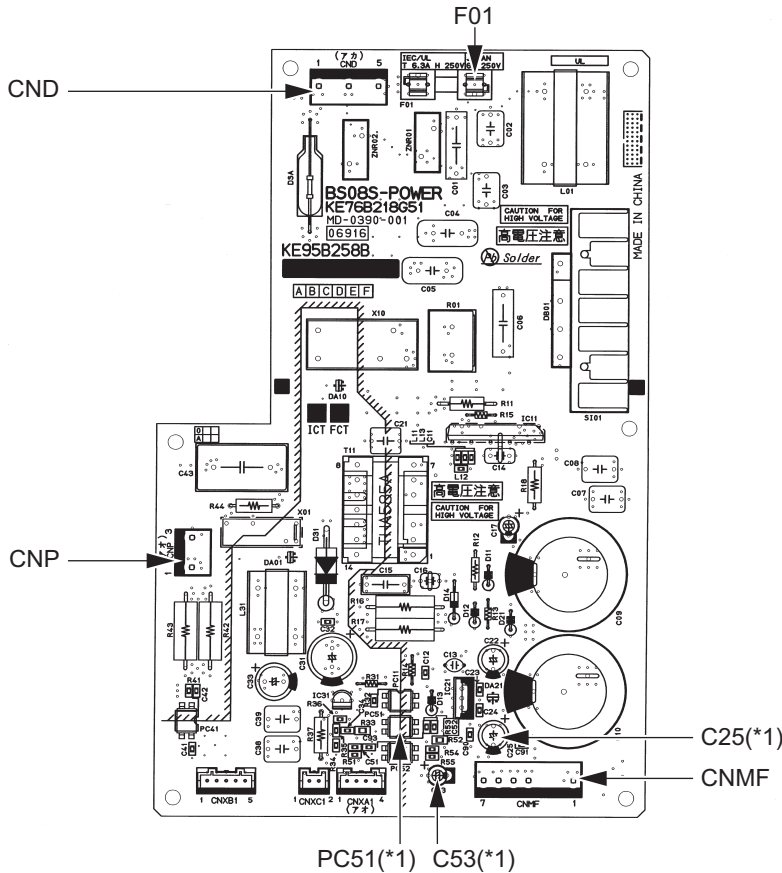

Power supply board

- F01 Fuse(AC 250V 6.3A)
- CND Power supply voltage (220 - 240VAC)
- CN2M For M-NET transmission cable connection (24 - 30VDC)
- SWE Emergency operation
- SW2 Capacity setting
- SW4 Function setting
- SW3 Function setting
- CN32 Remote start/stop adapter
- CN3A For MA remote controller cable connection (10 - 13 VDC (Between 1 and 3.))
- CN52 Remote display
- CN51 Centralized control
- CN41 JAMA standard HA terminal A
- CN44 Thermistor (water inlet / water outlet temperature)
- CN4F Float thermistor
- CN20 Thermistor (Inlet temperature)
- CNMF Fan motor output  
 1 - 4: 310 - 340 VDC  
 5 - 4: 15 VDC  
 6 - 4: 0 - 6.5 VDC  
 7 - 4: Stop 0 or 15 VDC  
 Run 7.5 VDC  
 (0 - 15 pulse)
- CNP Drain-up mechanism output (200VAC)
- (\*1)  
 $V_{FG}$  Voltage on the (-) side of PC51 and C25  
 (Same with the voltage between 7 (+) and 4 (-) of CNMF)  
 $V_{CC}$  Voltage between the C25 pins  
 15 VDC  
 (Same with the voltage between 5 (+) and 4 (-) of CNMF)  
 $V_{sp}$  Voltage between the C53 pins  
 0VDC (with the fan stopped)  
 1 - 6.5VDC (with the fan in operation)  
 (Same with the voltage between 6 (+) and 4 (-) of CNMF)

### 5. Dipswitch setting (Factory setting)

1. Function setting

(1) SW1

Switch position	Function	Switch setting	
		ON	OFF
1	Active Thermistor (Intake air thermistor)	Built-in thermistor on the remote controller	Indoor unit
2	Filter clogging detection	Available	Unavailable
3	Filter life	2500 hr	100 hr
4	Outdoor air intake	Enabled	Disabled
5	Remote display	Thermo-ON signal	Fan output
6	Humidifier operation	During heating mode	During heating operation
7	Fan speed	Low	Very low
8	Fan speed at heating Thermo-OFF	Preset fan speed	Follows the setting of SW1-7
9	Auto restart after power failure	Enabled	Disabled
10	Power start/stop	Enabled	Disabled

1) Address board

Factory setting

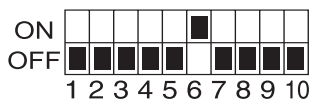

(2) SW3

Switch position	Function	Switch setting	
		ON	OFF
1	Unit type	Cooling only	Heat pump
2	-	-	-
3	-	-	-
4	-	-	-
5	-	-	-
6	-	-	-
7	-	-	-
8	Heating 4-deg up	Disabled	Enabled
9	-	-	-
10	-	-	-

1) Indoor control board

Dipswitch settings must be made while the unit is stopped.

Factory setting

PEFY-WP20, 25, 32, 40, 50VMA-E

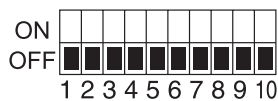

2. Capacity code setting

(1) SW2

1) Indoor control board

Dipswitch settings must be made while the unit is stopped.

Factory setting

The switches are set to correspond to the unit capacity.

PEFY-WP20VMA-E

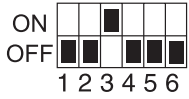

PEFY-WP25VMA-E

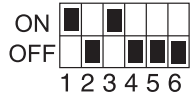

PEFY-WP32VMA-E

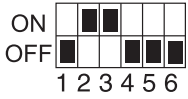

PEFY-WP40VMA-E

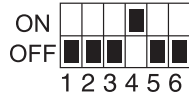

PEFY-WP50VMA-E

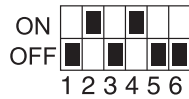

3. Model setting

(1) SW4

1) Indoor control board

Dipswitch settings must be made while the unit is stopped.

Factory setting

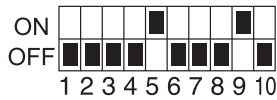

Note:

Changes made to the dipswitches SW1, SW2, and SW3 will become effective when the unit comes to a stop (remote controller off). There is no need to power cycle the unit.

4. Power voltage setting

(1) SW5

1) Indoor control board

Dipswitch settings must be operated with the main power turned OFF.

Factory setting



Set SW5 to 240V side when the power supply is 240 volts.  
When the power supply is 220 and 230 volts, set SW5 to 220V side.

5. External static pressure

(1) SWA, SWC

1) Indoor control board

All models

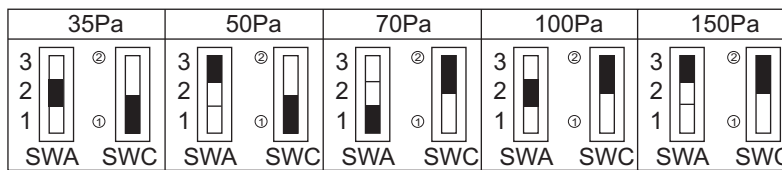

Factory setting

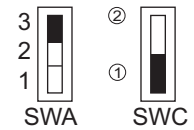

Note:

Changes that are made to the dipswitches SWA and SWC immediately become effective regardless of the unit's operation status (RUN/STOP) or the remote controller status (ON/OFF).

6. 1s and 10ths digits

(1) SW11, SW12 (Rotary switch)

The use of a network remote controller (PAR-F27MEA) requires address setting.

1) Indoor control board

Address settings must be made while the unit is stopped.

Factory setting

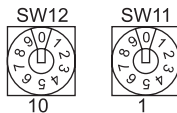

7. Connection No. setting

(1) SW14 (Rotary switch)

This switch is used when the unit connected to an R2 series of outdoor unit.

1) Indoor control board

Factory setting



Note:

Changes to the dipswitches SW11, SW12, SW14, and SW15 must be made while the unit is stopped and the remote controller is OFF.



---

## [1] Disassembly Procedure

---

### 1. Control box

**Exercise caution when removing heavy parts.**

1. Removing the control box cover
  - (1) Remove the three fixing screws on the cover (A) to remove it.

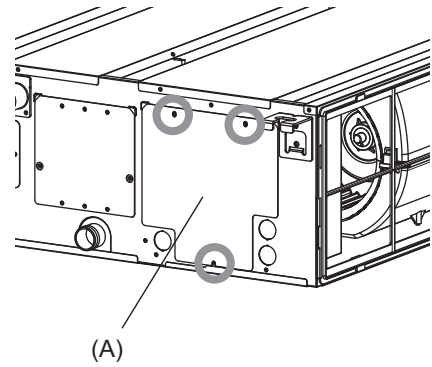

Fig.1

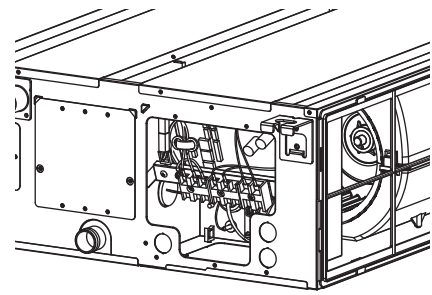

Fig.2

## 2. Thermistor (Intake air)

Exercise caution when removing heavy parts.

1. Remove the control box cover according to the procedure in **section 1**.
2. Remove the thermistor.
  - (1) Pull out the thermistor holder (B) and thermistor (C) on the control box.

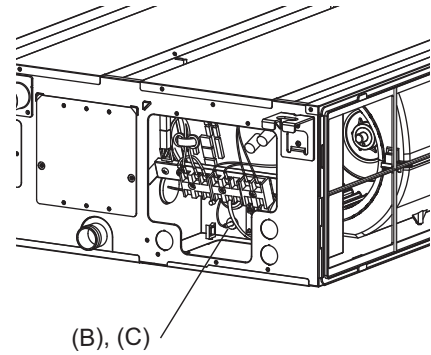

Fig.3

### 3. Drainpan

Exercise caution when removing heavy parts.

1. Removing the filter and the bottom plate

- (1) Push down the tab on the filter, and pull out the filter in the direction of the arrow 1.
- (2) Remove the fixing screws on the bottom plate (D), (E) to remove it.

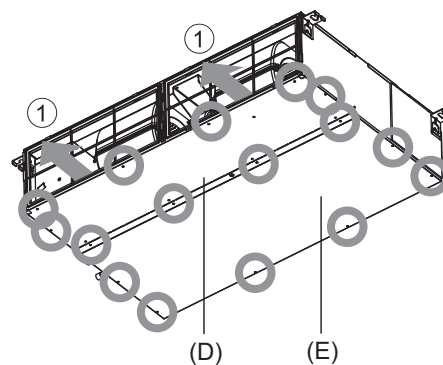

Fig.4

2. Removing the drainpan

- (1) Pull out the drainpan in the direction of the arrow 2.

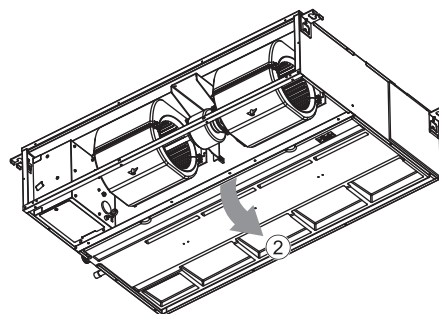

Fig.5

**Note**  
•Drain the water out of the drain pan before removing it.

#### 4. Thermistor (Water outlet) (Water inlet)

Exercise caution when removing heavy parts.

1. Remove the drain pan according to the procedure in **section 3**.
2. Removing the Heat exchanger cover
  - (1) Remove the four fixing screws on the heat exchanger cover (F) to remove it.

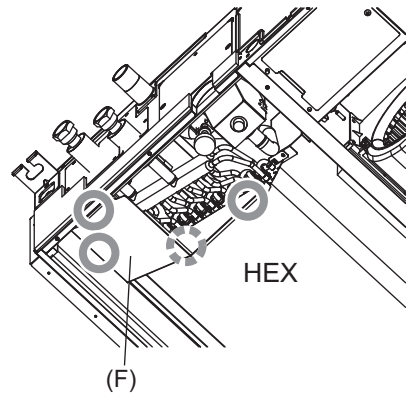

Fig.6

3. Removing the thermistor
  - (1) Remove the thermistor (G) from the thermistor holder (H) on the copper tube.

Thermistor size  
Water inlet:  $\varnothing 8\text{mm}$   
Water outlet:  $\varnothing 6\text{mm}$

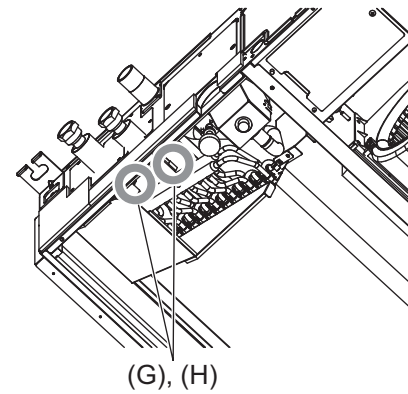

Fig.7

## 5. Fan and fan motor

Exercise caution when removing heavy parts.

### 1. Removing the filter and the bottom plate

- (1) Push down the tab on the filter, and pull out the filter in the direction of the arrow 1.
- (2) Remove the fixing screws on the bottom plate (J) to remove it.

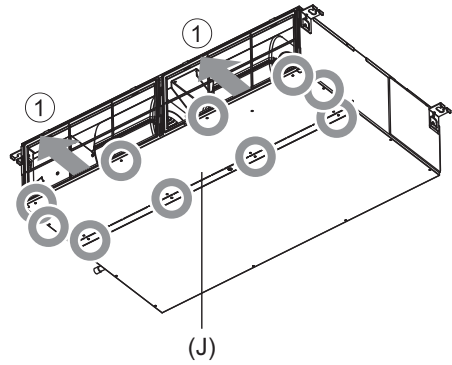

Fig.8

(a) Tab

### 2. Removing the fan casing (bottom half)

- (1) Squeeze the tabs on the fan casing to remove it in the direction of arrow 2.

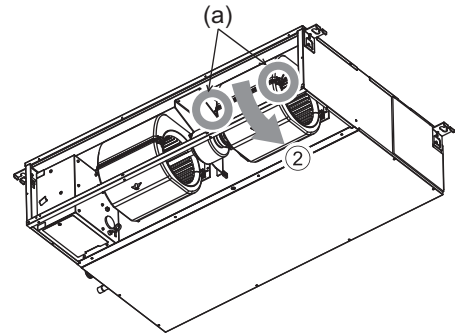

Fig.9

### 3. Removing the motor cable

- (1) Remove the motor cable through the rubber bush.

### 4. Removing the fan motor and the Sirocco fan

- (1) Remove the two motor fixing screws to remove the motor and the Sirocco fan in the direction of arrow 3.

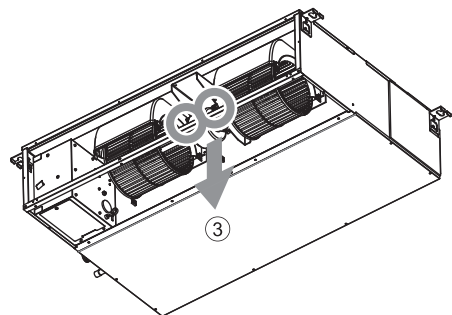

Fig.10

- (2) Remove the four fan case fixing screws to take the top half of the fan casing off.

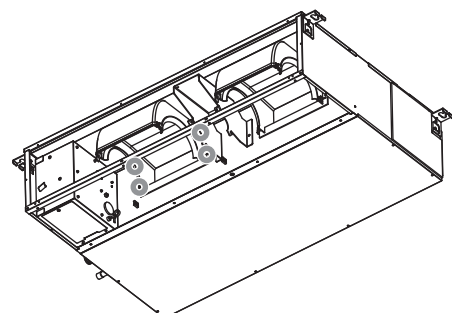

Fig.11

## 6. Heat exchanger

Exercise caution when removing heavy parts.

1. Remove the drain pan according to the procedure in **section 3**.
2. Remove the heat exchanger cover according to the procedure in **section 4. 2**.
3. Removing the cover
  - (1) Remove the five fixing screws on the cover (K) to remove it.

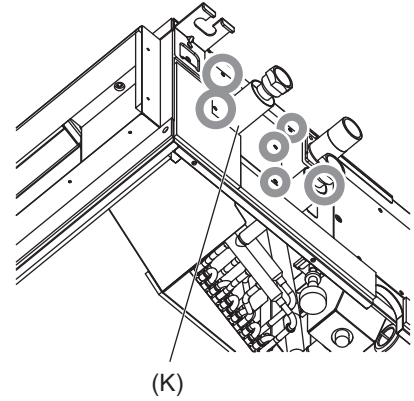

Fig.12

(K) Pipe support plate

4. Removing the Heat exchanger
  - (1) Remove the fixing screws on the heat exchanger (M) to remove it.

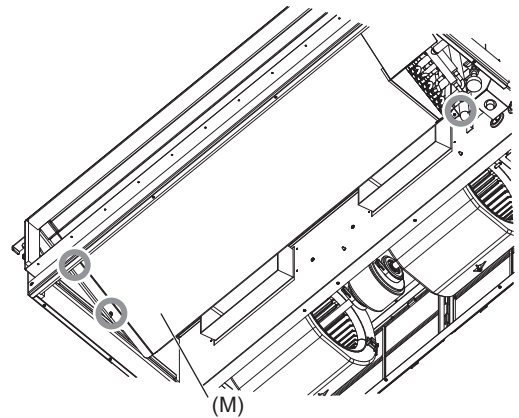

Fig.13



# **mitsubishi electric corporation**

<http://Global.MitsubishiElectric.com>

---