

Air-Conditioners For Building Application INDOOR UNIT

PKFY-P-VBM-E

For use with the R410A
Bei Verwendung von R410A
A utiliser avec le R410A
Bij gebruik van R410A
Para utilizar con el R410A

Usò del refrigerante R410A
Για χρήση με τα R410A
Para utilização com o R410A
R410A ile beraber kullanmak için
Для использования с моделями R410A

INSTALLATION MANUAL

For safe and correct use, please read this installation manual thoroughly before installing the air-conditioner unit.

FOR INSTALLER

INSTALLATIONSHANDBUCH

Zum sicheren und ordnungsgemäßen Gebrauch der Klimaanlage das Installationshandbuch gründlich durchlesen.

FÜR INSTALLATEURE

MANUEL D'INSTALLATION

Veuillez lire le manuel d'installation en entier avant d'installer ce climatiseur pour éviter tout accident et vous assurer d'une utilisation correcte.

POUR L'INSTALLATEUR

INSTALLATIEHANDLEIDING

Voor een veilig en juist gebruik moet u deze installatiehandleiding grondig doorlezen voordat u de airconditioner installeert.

VOOR DE INSTALLATEUR

MANUAL DE INSTALACIÓN

Para un uso seguro y correcto, lea detalladamente este manual de instalación antes de montar la unidad de aire acondicionado.

PARA EL INSTALADOR

MANUALE DI INSTALLAZIONE

Per un uso sicuro e corretto, leggere attentamente questo manuale di installazione prima di installare il condizionatore d'aria.

PER L'INSTALLATORE

ΕΓΧΕΙΡΙΔΙΟ ΟΔΗΓΙΩΝ ΕΓΚΑΤΑΣΤΑΣΗΣ

Για ασφάλεια και σωστή χρήση, παρακαλείστε διαβάστε προσεκτικά αυτό το εγχειρίδιο εγκατάστασης πριν αρχίσετε την εγκατάσταση της μονάδας κλιματισμού.

ΓΙΑ ΑΥΤΟΝ ΠΟΥ ΚΑΝΕΙ ΤΗΝ ΕΓΚΑΤΑΣΤΑΣΗ

MANUAL DE INSTALAÇÃO

Para segurança e utilização correctas, leia atentamente este manual de instalação antes de instalar a unidade de ar condicionado.

PARA O INSTALADOR

MONTAJ ELKİTABI

Emniyetli ve doğru biçimde nasıl kullanılacağını öğrenmek için lütfen klima cihazını monte etmeden önce bu elkitabını dikkatle okuyunuz.

MONTÖR İÇİN

РУКОВОДСТВО ПО УСТАНОВКЕ

Для осторожного и правильного использования прибора необходимо тщательно ознакомиться с данным руководством по установке до выполнения установки кондиционера.

ДЛЯ УСТАНОВИТЕЛЯ**English (GB)****Deutsch (D)****Français (F)****Nederlands (NL)****Español (E)****Italiano (I)****Ελληνικά (GR)****Português (P)****Türkçe (TR)****Русский (RU)**

Contents

1. Safety precautions.....	2	4. Refrigerant pipe and drain pipe.....	4
2. Installation location.....	2	5. Electrical work.....	6
3. Installing the indoor unit.....	3	6. Test run.....	7

Note:
The phrase "Wired remote controller" in this installation manual refers only to the PAR-21MAA.
If you need any information for the other remote controller, please refer to either the installation manual or initial setting manual which are included in these boxes.

1. Safety precautions

- ▶ Before installing the unit, make sure you read all the "Safety precautions".
- ▶ Please report to your supply authority or obtain their consent before connecting this equipment to the power supply system.

Warning:
Describes precautions that must be observed to prevent danger of injury or death to the user.

Caution:
Describes precautions that must be observed to prevent damage to the unit.

After installation work has been completed, explain the "Safety Precautions," use, and maintenance of the unit to the customer according to the information in the Operation Manual and perform the test run to ensure normal operation. Both the Installation Manual and Operation Manual must be given to the user for keeping. These manuals must be passed on to subsequent users.

- Warning:**
- Ask the dealer or an authorized technician to install the air conditioner.
 - Install the unit at a place that can withstand its weight.
 - If the supply cord is damaged, it must be replaced by the manufacturer, its service agent or similarly qualified persons in order to avoid a hazard.
 - The user should never attempt to repair the unit or transfer it to another location.
 - The appliance shall be installed in accordance with national wiring regulations.
 - Use only specified cables for wiring. The wiring connections must be made securely with no tension applied on the terminal connections. Also, never splice the cables for wiring (unless otherwise indicated in this document). Failure to observe these instructions may result in overheating or a fire.
 - Use only accessories authorized by Mitsubishi Electric and ask the dealer or an authorized technician to install them.
 - Do not touch the heat exchanger fins.

- Caution:**
- Do not use the existing refrigerant piping, when use R410A refrigerant.
 - Use ester oil, either oil or alkybenzene (small amount) as the refrigerant oil to coat flares and flange connections, when use R410A refrigerant.
 - Do not use the air conditioner where food, pets, plants, precision instruments, or artwork are kept.
 - Do not use the air conditioner in special environments.
 - Ground the unit.

- ⊘ : Indicates an action that must be avoided.
- ⚠ : Indicates an important instructions that must be followed.
- ⚡ : Indicates a part which must be grounded.
- ⚠ : Indicates that caution should be taken with rotating parts.
- ⚠ : Indicates that the main switch must be turned off before servicing.
- ⚠ : Beware of electric shock.
- ⚠ : Beware of hot surface.
- ⚠ ELY : At servicing, please shut down the power supply for both the Indoor and Outdoor Unit.

Warning:
Carefully read the labels affixed to the main unit.

- Install the air conditioner according to this Installation Manual.
- Have all electric work done by a licensed electrician according to local regulations.
- If the air conditioner is installed in a small room, measures must be taken to prevent the refrigerant concentration from exceeding the safety limit even if the refrigerant should leak.
- The cut face punched parts may cause injury by cut, etc. The installers are requested to wear protective equipment such as gloves, etc.
- When installing or relocating, or servicing the air conditioner, use only the specified refrigerant (R410A) to charge the refrigerant lines. Do not mix it with any other refrigerant and do not allow air to remain in the lines. If air is mixed with the refrigerant, then it can be the cause of abnormal high pressure in the refrigerant line, and may result in an explosion and other hazards. The use of any refrigerant other than that specified for the system will cause mechanical failure or system malfunction or unit breakdown. In the worst case, this could lead to a serious impediment to securing product safety.

- Install an leak circuit breaker, as required.
- Use power line cables of sufficient current carrying capacity and rating.
- Use only a circuit breaker and fuse of the specified capacity.
- Do not touch the switches with wet fingers.
- Do not touch the refrigerant pipes during and immediately after operation.
- Do not operate the air conditioner with the panels and guards removed.
- Do not turn off the power immediately after stopping operation.

2. Installation location

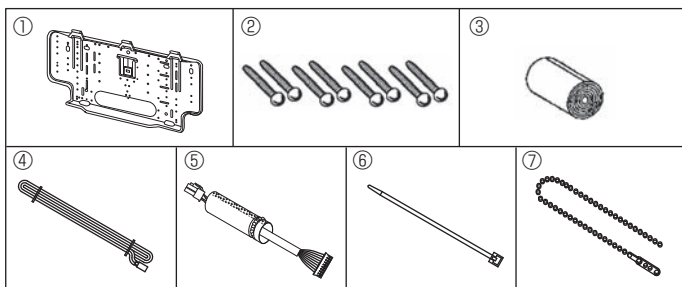

The indoor unit comes with the following parts and accessories:

PART NUMBER	ACCESSORY	QUANTITY	LOCATION OF SETTING
①	Wall-fixing bracket	1	Fix at the back of the unit
②	Tapping screw 4 × 25	8	Set in packing material
③	Felt tape	1	
④	MA remote controller cable	1	
⑤	Cable	1	
⑥	Band	1	
⑦	Fastener	1	

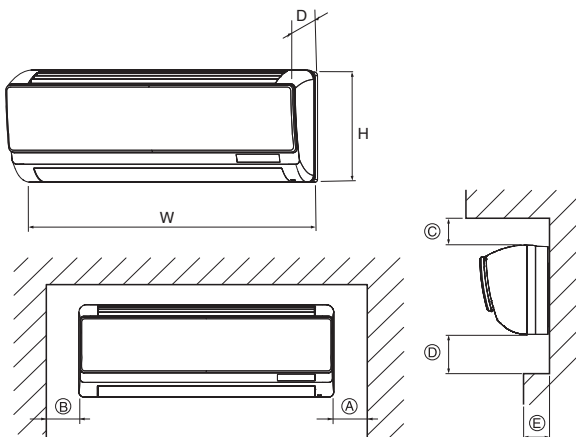

Fig. 2-1

2.1. Outline dimensions (Indoor unit) (Fig. 2-1)

Select a proper position allowing the following clearances for installation and maintenance.

Models	W	D	H	A	B	C*1	D	E
PKFY-P-VBM	815	225	295	Min. 20	Min. 22	Min. 50	Min. 100	Max. 90

*1 : 60mm or more for left and left back piping.

Warning:
Mount the indoor unit on a wall strong enough to withstand the weight of the unit.

3. Installing the indoor unit

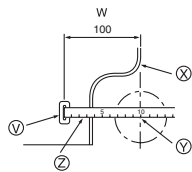
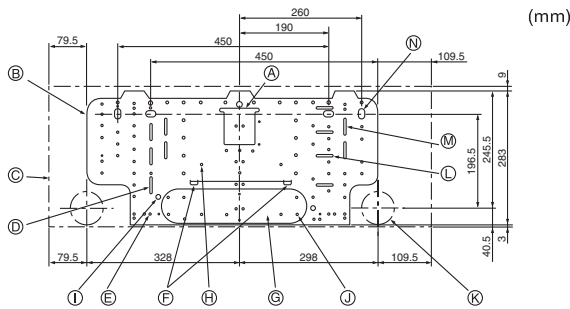

Fig. 3-1

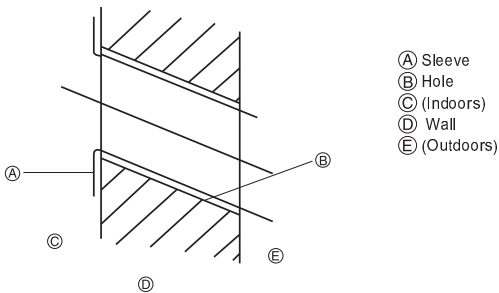

Fig. 3-2

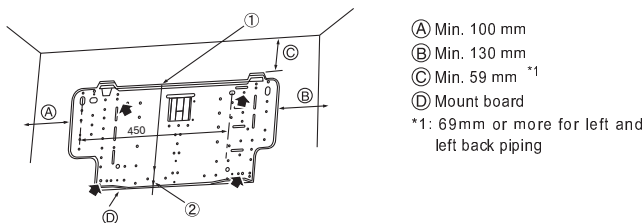

Fig. 3-3

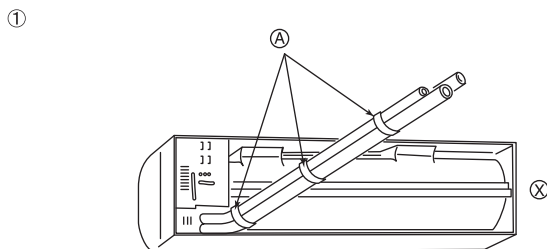

Fig. 3-4

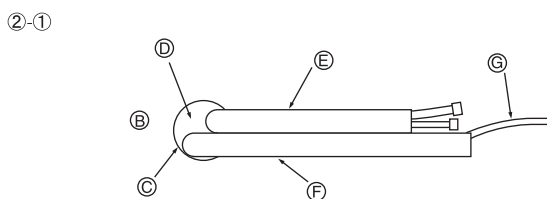

Fig. 3-5

3.1. Installing the wall mounting fixture (Fig. 3-1)

3.1.1. Setting the wall mounting fixture and piping positions

- ▶ Using the wall mounting fixture, determine the unit's installation position and the locations of the piping holes to be drilled.

⚠ Warning:

Before drilling a hole in the wall, you must consult the building contractor.

- | | |
|-----------------------------------|------------------------------------|
| (A) Supporting piece | (H) Knockout hole (12- ϕ 2.6) |
| (B) Mount board | (I) Knockout hole (4- ϕ 9) |
| (C) Main body | (J) Knockout hole (87- ϕ 5.4) |
| (D) Slot (4-4.5 x 35) | (K) Piping hole (ϕ 65) |
| (E) Knockout hole (8- ϕ 4.3) | (L) Slot (4-4.5 x 40) |
| (F) Level setting standard | (M) Slot (4-4.5 x 37) |
| (G) Knockout hole | (N) Slot (4-11 x 20) |

W: Location for wall holes

- (X) Wall mounting fixture
- (Y) Hole centre
- (Z) Align the scale with the line.
- (V) Insert scale.

3.1.2. Drilling the piping hole (Fig. 3-2)

- ▶ Use a core drill to make a hole of 90-100 mm diameter in the wall in the piping direction, at the position shown in the diagram to the left.
- ▶ The hole should incline so that the outside opening is lower than the inside opening.
- ▶ Insert a sleeve (with a 90 mm diameter and purchased locally) through the hole.

Note:

The purpose of the hole's inclination is to promote drain flow.

3.1.3. Installing the wall mounting fixture

- ▶ Since the indoor unit weighs near 10 kg, selection of the mounting location requires thorough consideration. If the wall does not seem to be strong enough, reinforce it with boards or beams before installation.
- ▶ The mounting fixture must be secured at both ends and at the centre, if possible. Never fix it at a single spot or in any unsymmetrical way. (If possible, secure the fixture at all the positions marked with a bold arrow.) (Fig. 3-3)

⚠ Warning:

If possible, secure the fixture at all positions indicated with a bold arrow.

⚠ Caution:

- The unit body must be mounted horizontally.
- Fasten at the holes marked with ▲ as shown by the arrows.

- ① Fasten a thread to the hole.
- ② The level can be easily obtained by hanging a weight from the string and aligning the string with the mark.

3.2. Preparation for piping connection

- ▶ Remove the vinyl band that holds the drain pipe.
- ① Rear, right and lower piping (Fig. 3-4)
- ▶ Bind the refrigerant pipes and drain pipe with vinyl tape at three or more points. This will facilitate passing the pipes through the wall.

- (A) Vinyl tape
- (X) This figure is viewed from the back of the unit.
- ② Left and left rear piping

- ②-① For left rear piping, pull the pipes out the hole to determine their correct length, then bend them. The indoor unit should hang on the wall mounting fixture. (Fig. 3-5)

- (B) Wall
- (C) Wall hole
- (D) Bent section
- (E) Refrigerant pipe
- (F) Drain pipe
- (G) Transmission cable

3. Installing the indoor unit

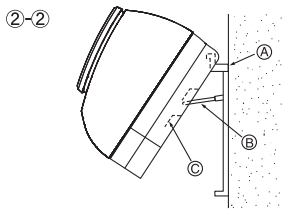

Fig. 3-6

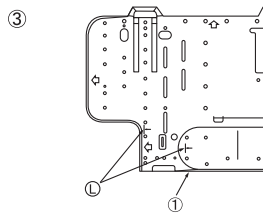

Fig. 3-7

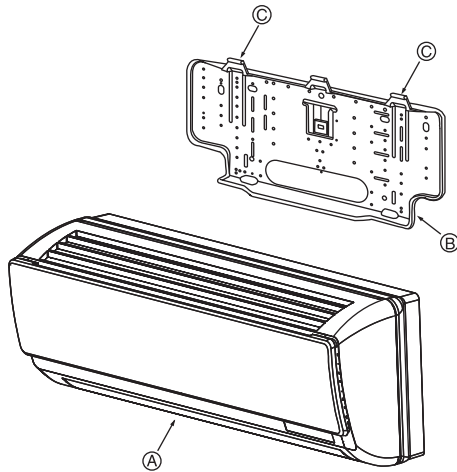

Fig. 3-8

- ②-② Lift the indoor unit by hooking the supporting piece (attached to the mount board) to the ribs on the back of the unit as shown. (Fig. 3-6)
When piping work etc. is complete, replace the supporting piece on the mount board.
(If the unit is not fixed securely, vibration may occur during operation.)

- Ⓐ Mount board
- Ⓑ Supporting piece
- Ⓒ Rib

- ③ If the flare pipe is to be embedded into the wall in advance: (Fig. 3-7)

- Determine the length of pipe to be embedded by marking on the mounting plate as a reference.

- Ⓐ Mark
- ① Wall mounting fixture

3.3. Mounting the unit (Fig. 3-8)

- ① Securely place the hanging fixtures for the indoor unit over the catches on the wall mounting fixture.

- Ⓐ Indoor unit
- Ⓑ Wall mounting fixture
- Ⓒ Catch

- ② When piping has been completed, install the indoor unit and wall mounting fixture with fixing screws.

4. Refrigerant pipe and drain pipe

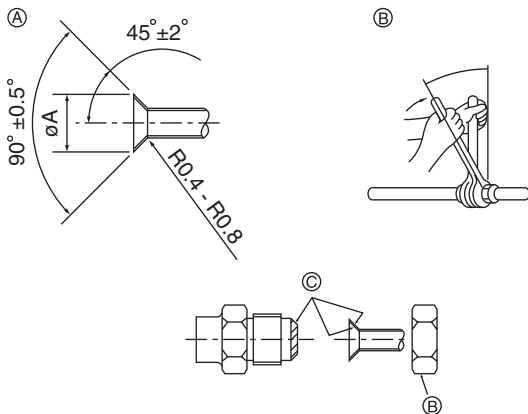

Fig. 4-1

4.1. Connecting pipes (Fig. 4-1)

- When commercially available copper pipes are used, wrap liquid and gas pipes with commercially available insulation materials (heat-resistant to 100 °C or more, thickness of 12 mm or more).
- The indoor parts of the drain pipe should be wrapped with polyethylene foam insulation materials (specific gravity of 0.03, thickness of 9 mm or more).
- Apply thin layer of refrigerant oil to pipe and joint seating surface before tightening flare nut.
- Use two wrenches to tighten piping connections.
- Use refrigerant piping insulation provided to insulate indoor unit connections. Insulate carefully.

⚠ Warning:

When installing the unit, securely connect the refrigerant pipes before starting the compressor.

Ⓐ Flare cutting dimensions

Copper pipe O.D. (mm)	Flare dimensions øA dimensions (mm)
ø6.35	8.7 - 9.1
ø12.7	16.2 - 16.6

Ⓑ Refrigerant pipe sizes & Flare nut tightening torque

	R410A				Flare nut O.D.	
	Liquid pipe		Gas pipe		Liquid pipe (mm)	Gas pipe (mm)
	Pipe size (mm)	Tightening torque (N.m)	Pipe size (mm)	Tightening torque (N.m)		
P15/P20/25	ODø6.35 (1/4")	14 - 18	ODø12.7 (1/2")	49 - 61	17	26

Ⓒ Do not apply refrigerating machine oil to the screw portions.
(This will make the flare nuts more apt to loosen.)

Ⓓ Be certain to use the flare nuts that are attached to the main unit.
(Use of commercially-available products may result in cracking.)

Ⓔ Apply refrigerating machine oil over the entire flare seat surface.

4. Refrigerant pipe and drain pipe

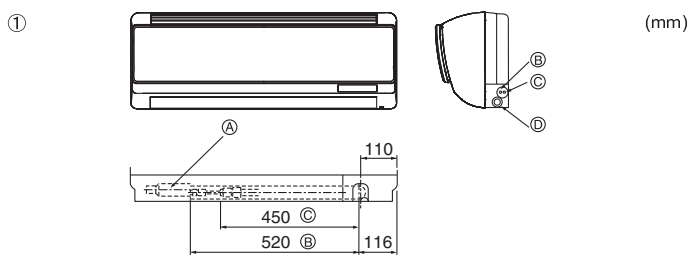

Fig. 4-2

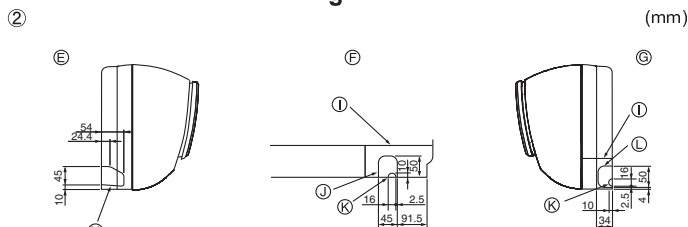
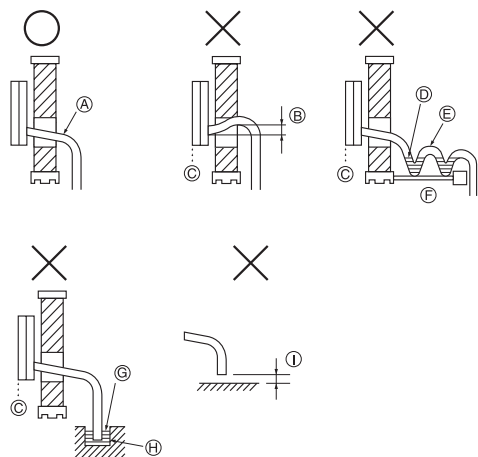

Fig. 4-3



- (A) Inclined downwards
- (B) Must be lower than outlet point
- (C) Water leakage
- (D) Trapped drainage
- (E) Air
- (F) Wavy
- (G) The end of drain pipe is under water.
- (H) Drainage ditch
- (I) 5 cm or less between the end of drain pipe and the ground

Fig. 4-4

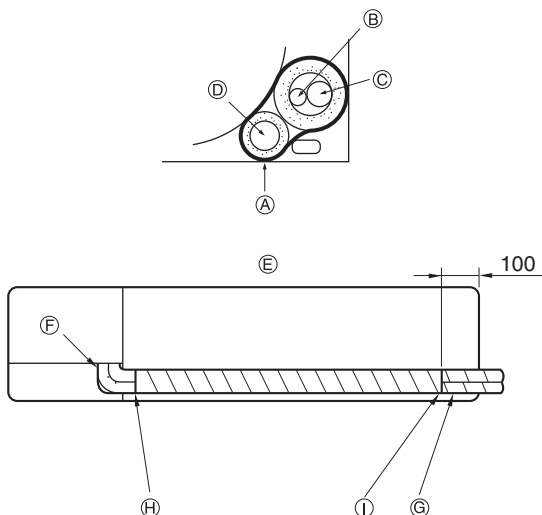

Fig. 4-5

4.2. Positioning refrigerant and drain piping

- ① Position of refrigerant and drain piping (Fig. 4-2)
- The drain pipe can be cut midway to meet the on-site conditions.
 - (A) (Effective length: 640)
 - (B) Liquid pipe
 - (C) Gas pipe
 - (D) Drain hose

- ② Determine the position of the knockout holes on the unit body. (Fig. 4-3)

► **Cut the knockout holes using a saw blade or an adequate knife.**
Take care not to damage other parts of the unit.

- Remove the corner box and drill a knockout hole. If a hole is made without removing the box, the drain hose could be damaged.

- (E) Left-side piping
- (F) Lower piping
- (G) Right-side piping
- (H) Knockout hole for left-side piping
- (I) Corner box
- (J) Knockout hole for lower piping
- (K) Through hole for the remote controller's cable
- (L) Knockout hole for right-side piping

4.3. Drain piping (Fig. 4-4)

- Drain pipes should have an inclination of 1/100 or more.
- For extension of the drain pipe, use a soft hose (inner dia. 16 mm) available on the market or hard vinyl chloride pipe (VP-16). Make sure that there is no water leakage from the connections.
- If the drain pipe passes indoors it must be covered with insulating material (foamed polyethylene: specific gravity: 0.03, thickness: 9 mm or more) available on the market.
- Do not put the drain piping directly in a drainage ditch where sulphuric gas may be generated.
- When piping has been completed, check that water flows from the end of the drain pipe.

⚠ Caution:

The drain pipe should be installed according to this Installation Manual to ensure correct drainage. Thermal insulation of the drain pipes is necessary to prevent condensation. If the drain pipes are not properly installed and insulated, condensation may drip on the ceiling, floor or other possessions.

4.4. Completing the piping (Fig. 4-5)

- To prevent condensation from dripping, put felt tape over the insulation materials on the refrigerant and drain pipes within the unit as shown in the diagram.
- Arrange the drain hose so that it goes to the bottom of the unit.
- The overlapping width of felt tape is one half of the tape width.
 - (A) Felt tape
 - (B) Liquid pipe
 - (C) Gas pipe
 - (D) Drain piping
 - (E) Viewed from the back
 - (F) Take care that the middle of the drain hose is not raised.
 - (G) In the case of left piping, the refrigerant pipes and the drain pipe should be taped separately.
 - (H) Wrap together the refrigerant pipes and the drain pipe with felt tape so that white felt overlaps by 20 mm or more.
 - (I) The pipes should be wrapped so that they are housed behind the unit.
- Fix the end of the felt tape with a bandage fixture.

5. Electrical work

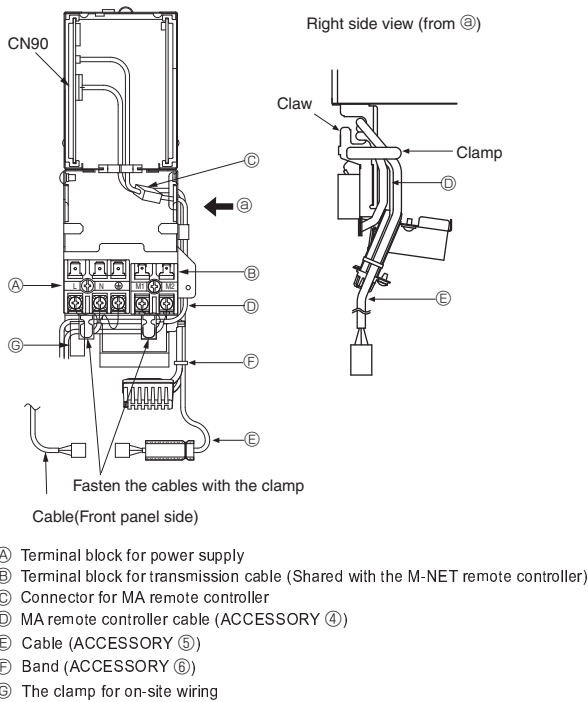

Fig. 5-1

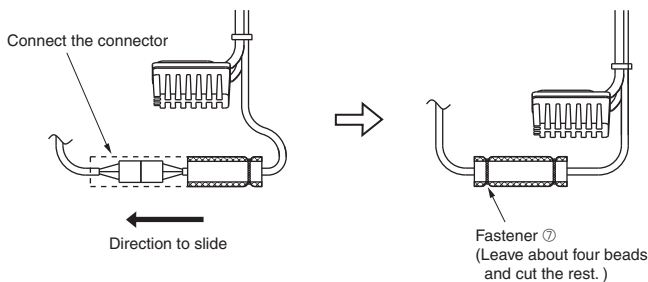

Fig. 5-2

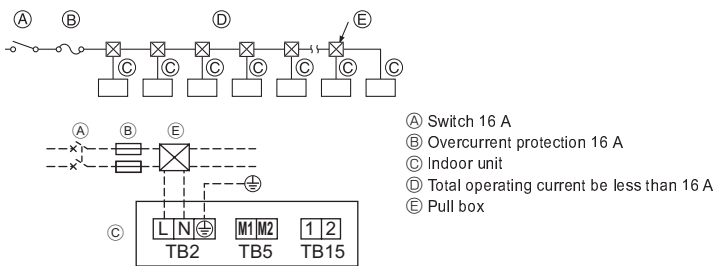

Fig. 5-3

5.1. Indoor unit (Fig. 5-1,5-2)

- 1) Remove the front panel, then remove the corner box from the lower right corner of the indoor unit.
- 2) Remove the screw fixing the electric parts cover and remove the cover.
- 3) Connect the power cable and transmission cable to the terminal block.
 - The electric parts box may have to be pulled forward during customer service etc. Therefore, the wires must have some extra length.
- 4) Connect the connector for MA remote controller. (Non-polarized 2-wire)
- 5) Connect the attached cable ⑤ to the CN90 on controller board in the electrical parts box.
 - * Be sure to connect in case of using MA/M-NET Remote controller.
- 6) Fix the MA Remote controller cable ④ and the cable ⑤ with the clamp through the claw on the right side of the electrical parts box.
- 7) Fix the MA remote controller cable ④ on the fixing clamp with the cable running along the down side of the terminal block.
- 8) Fix the cable ⑤ with the attached band ⑥.
- 9) Bring out the lead wire on the back side of the front panel to the corner box side. Put back the electrical cover and front panel. (Do not pull the lead wire strongly.)
- 10) After connecting the connectors (yellow 9-pole) on the indoor unit and front panel, slide the glass tube and fix it with the attached fastener ⑦ at which the connector joint part is not exposed.
 - * Be sure to connect in case of using MA/M-NET Remote controller.
- 11) Fix each wire with the clamp for on-site wiring under the electrical parts box and put the corner box cover back.

A means for the disconnection of the supply with an isolation switch, or similar device, in all active conductors shall be incorporated in the fixed wiring.

5.2. Power supply wiring

- Wiring size must comply with the applicable local and national code.
 - Power supply codes of appliance shall not be lighter than design 245 IEC 53 or 227 IEC 53.
 - Install an earth line longer than other cables.
 - A switch with at least 3 mm, 1/8 inch contact separation in each pole shall be provided by the air conditioner installation.
- Power cable size : more than 1.5mm² (3-core)

⚠ Warning:

Never splice the power cable or the indoor-outdoor connection cable, otherwise it may result in a smoke, a fire or communication failure.

- ▶ Selecting non-fuse breaker (NF) or earth leakage breaker (NV).

For breaker, means shall be provided to ensure disconnection of all active phase conductors of the supply.

5.3. Types of control cables

1. Wiring transmission cables

Types of transmission cable	Shielding wire CVVS or CPEVS
Cable diameter	More than 1.25 mm ²
Length	Less than 200m

2. M-NET Remote control cables

Types of remote control cable	Shielding wire MVVS
Cable diameter	More than 0.5 to 1.25 mm ²
Length	Add any portion in excess of 10m to within the longest allowable transmission cable length 200m.

3. MA Remote control cables

Types of remote control cable	2-core cable (unshielded)
Cable diameter	0.3 to 1.25 mm ²
Length	Less than 200m

5.4. Connecting remote controller, indoor and outdoor transmission cables (Fig. 5-4)

- Connect indoor unit TB5 and outdoor unit TB3. (Non-polarized 2-wire) The "S" on indoor unit TB5 is a shielding wire connection. For specifications about the connecting cables, refer to the outdoor unit installation manual.

Note:

As for PKFY-P-BM series, TB5 has two terminals and does not have S terminal. The earths of shielding wires are crimping-connected. Insulate the connected parts with insulating tapes and so on.

- Install a remote controller following the manual supplied with the remote controller.
- Connect the remote controller's transmission cable within 10 m using a 0.75 mm² core cable. If the distance is more than 10 m, use a 1.25 mm² junction cable.

5. Electrical work

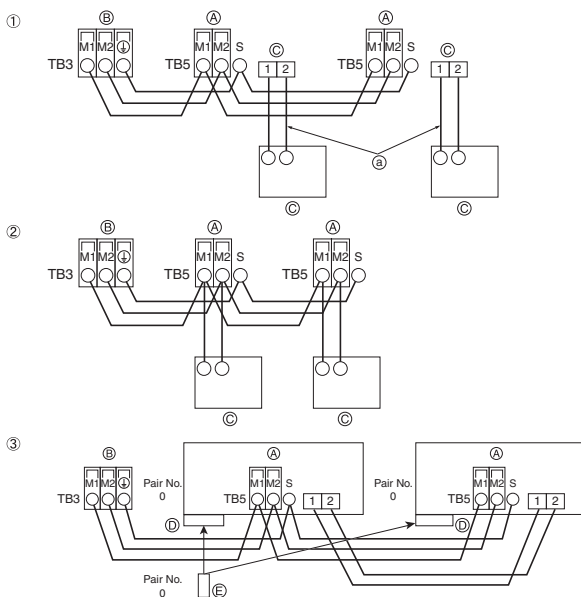

Fig. 5-4

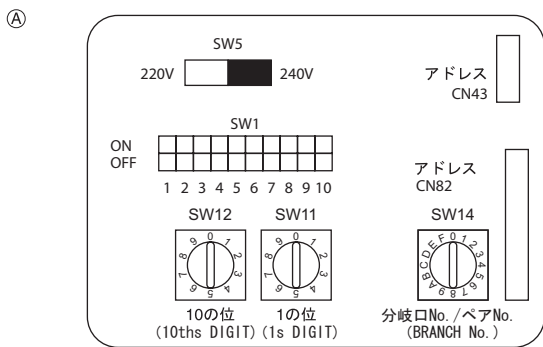

Fig. 5-5

6. Test run

6.1. Before test run

- ▶ After completing installation and the wiring and piping of the indoor and outdoor units, check for refrigerant leakage, looseness in the power supply or control wiring, wrong polarity, and no disconnection of one phase in the supply.
- ▶ Use a 500-volt megohmmeter to check that the resistance between the power supply terminals and ground is at least 1.0 MΩ.

- ▶ Do not carry out this test on the control wiring (low voltage circuit) terminals.

⚠ Warning:

Do not use the air conditioner if the insulation resistance is less than 1.0 MΩ.

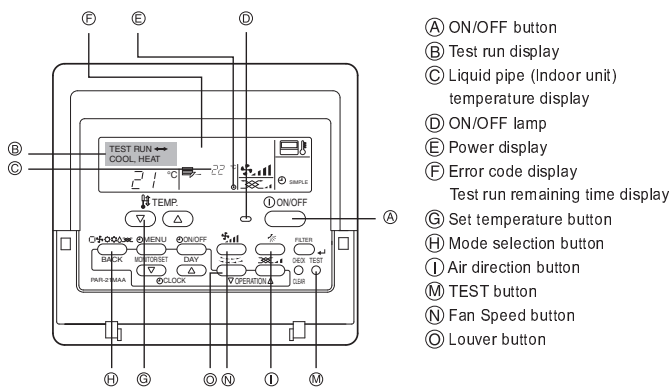

Fig. 6-1

6.2. Test run

Using wired remote controller (Fig. 6-1)

- 1 Turn on the power at least 12 hours before the test run.
- 2 Press the [TEST] button twice. ➡ "TEST RUN" liquid crystal display
- 3 Press the [Mode selection] button and switch to the cooling (or heating) mode. ➡ Make sure that cold (or warm) wind is blown out.
- 4 Press the [Fan speed] button. ➡ Make sure that the wind speed is switched.
- 5 Press the [Air direction button] or [Louver button]. ➡ Check operation of the vane or louver.
- 6 Check operation of the outdoor unit fan.
- 7 Release test run by pressing the [ON/OFF] button. ➡ Stop
- 8 Register a telephone number.

The telephone number of the repair shop, sales office, etc., to contact if an error occurs can be registered in the remote controller. The telephone number will be displayed when an error occurs. For registration procedures, refer to the operation manual for the indoor unit.

Note:

- If an error code is displayed on the remote controller or if the air conditioner does not operate properly, refer to the outdoor unit installation manual or other technical materials.
- The OFF timer is set for the test run to automatically stop after 2 hours.
- During the test run, the time remaining is shown in the time display.
- During the test run, the temperature of the indoor unit refrigerant pipes is shown in the room temperature display of the remote controller.
- When the VANE or LOUVER button is pressed, the message "NOT AVAILABLE" may appear on the remote controller display depending on the indoor unit model, but this is not a malfunction.

This product is designed and intended for use in the residential,
commercial and light-industrial environment.

Importer:

Mitsubishi Electric Europe B.V.
Capronilaan 46, 1119 NS, Schiphol Rijk, The Netherlands

French Branch
25, Boulevard des Bouvets, 92741 Nanterre Cedex, France

German Branch
Mitsubishi-Electric-Platz 1, 40882 Ratingen, Germany

Belgian Branch
Autobaan 2, 8210 Loppem, Belgium

Irish Branch
Westgate Business Park, Ballymount, Dublin 24, Ireland

Italian Branch
Centro Direzionale Colleoni, Palazzo Sirio-Ingresso 1 Viale Colleoni 7, 20864 Agrate Brianza
(MB), Italy

Norwegian Branch
Gneisveien 2D, 1914 Ytre Enebakk, Norway

Portuguese Branch
Avda. do Forte, 10, 2799-514, Carnaxide, Lisbon, Portugal

Spanish Branch
Carretera de Rubi 76-80 - Apdo. 420 08173 Sant Cugat del Valles (Barcelona), Spain

Scandinavian Branch
Hammarbacken 14, P.O. Box 750 SE-19127, Sollentuna, Sweden

UK Branch
Travellers Lane, Hatfield, Herts., AL10 8XB, England, U.K.

Polish Branch
Krakowska 50, PL-32-083 Balice, Poland

MITSUBISHI ELECTRIC TURKEY ELEKTRİK ÜRÜNLERİ A.Ş.
Şerifali Mah. Kale Sok. No: 41 34775 Ümraniye, İstanbul / Turkey

MITSUBISHI ELECTRIC (RUSSIA) LLC
52, bld.1 Kosmodamianskaya Nab. 115054, Moscow, Russia

Please be sure to put the contact address/telephone number on
this manual before handing it to the customer.