



Cooling | Heating | Ventilation | Controls



TIME FOR
R32





TIME FOR
R32



The Mr Slim R32 Power Inverter Range

A blend of energy efficiency and sophisticated design



TIME FOR R32

● **It's time** to enjoy energy savings and great new product features

● **It's time** to put R32 refrigerant at the heart of your conversations and plans moving forward, with the market leading range of R32 products from Mitsubishi Electric

● **It's time** for your air conditioning to help meet EU carbon emissions targets





The 2014 F-Gas Regulations have one key objective: **to reduce F-Gas emissions by 79% between 2015 and 2030**, by cutting the availability of hydrofluorocarbons (HFCs) with a high Global Warming Potential (GWP). It's time therefore to look at alternative, low GWP refrigerants such as R32.

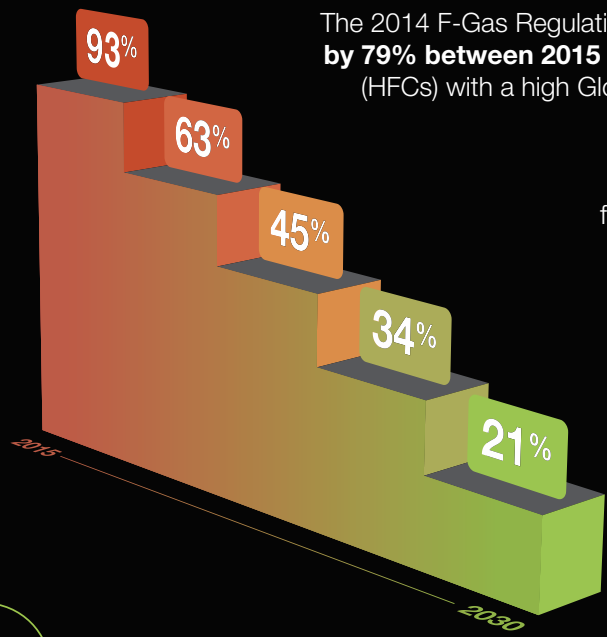

Already making up 50% of the existing R410A refrigerant found in many current air conditioning systems, **R32 has a GWP of 675 (one third that of R410A)**, is highly energy efficient and is easy to recycle. Plus, the volumetric capacity of R32 is around 20% higher than that of R410A, which means system refrigerant volumes are lower.

Benefits of R32

- Low GWP of 675
- High efficiency refrigerant
- F-Gas phase down compliant
- Less refrigerant volume requirement compared to R410A
- Affordable & readily available
- A single component refrigerant
- Easy to handle, reuse and recycle

The Mr Slim R32 Power Inverter Range

The Mr Slim R32 Power Inverter range blends a host of outstanding features with a premium quality, sophisticated design. Offering our highest seasonal efficiency levels, advanced control options and extended pipe runs, this range is extremely flexible and available in four different indoor unit types, from 3.5 to 14kW.

Industry Leading Seasonal Energy Efficiency Ratings

The R32 Power Inverter is able to achieve high seasonal efficiencies through the optimisation of a newly designed compressor and use of the latest energy-saving technologies. ERP energy efficiency ratings of A++ are common throughout the range, with annual power consumption drastically reduced, resulting in increased run cost savings.

Indoor Unit	Heating / Cooling						
	3.5kW	5.0kW	6.0kW	7.1kW	10.0kW	12.5kW	14.0kW
PLA-ZM 4-Way Blow Ceiling Cassette	A++ / A++	A++ / A++	A++ / A++	A++ / A++	A++ / A++	A++ / A++	A++ / A++
PKA-M Wall Mounted	A+ / A++	A+ / A++	A+ / A++	A+ / A++	A+ / A++	-	-
PEAD-M Ceiling Concealed Ducted	A / A+	A+ / A++	A+ / A++	A / A+	A+ / A++	A / A+	A+ / A+
PCA-M Ceiling Suspended	-	A+ / A++	A+ / A++	A+ / A++	A+ / A++	A+ / A++	A+ / A++

3-Phase Power Supply

The 10.0, 12.5 and 14.0kW models are also available as a 3-phase option. Choosing this option dramatically reduces the running current of the unit and subsequent fuse rating.

Power Supply		10.0kW	12.5kW	14.0kW
3-Phase	Max Running Current (A)	8.5	10.0	13.7
	Fuse Rating (A)	16	16	16
Power Supply		10.0kW	12.5kW	14.0kW
Single Phase	Max Running Current (A)	27.0	27.0	28.7
	Fuse Rating (A)	32	32	40

Note: Example using a 4-Way Blow Ceiling Cassette



● Increased Pipe Lengths

Pipe lengths of up to 100m with a 30m height difference are now available with the R32 Power Inverter, increasing the application possibilities of the range.

Outdoor Unit	Max Pipe Length (m)	Max Height Difference (m)
PUZ-ZM35/50VKA	50	30
PUZ-ZM60/71VHA	55 (5m increase over R410A PUHZ-ZRP Power Inverter)	30
PUZ-ZM100/125/140VKA/YKA	100 (25m increase over R410A PUHZ-ZRP Power Inverter)	30

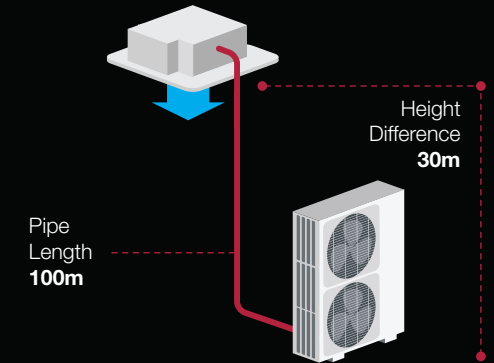

● Full Heating Capacity Down to -3°C

Designed to provide powerful heating, even on bitterly cold or snowy days. When compared to the R410A Power Inverter, the rated heating capacity is maintained down to outside temperatures of -3°C.

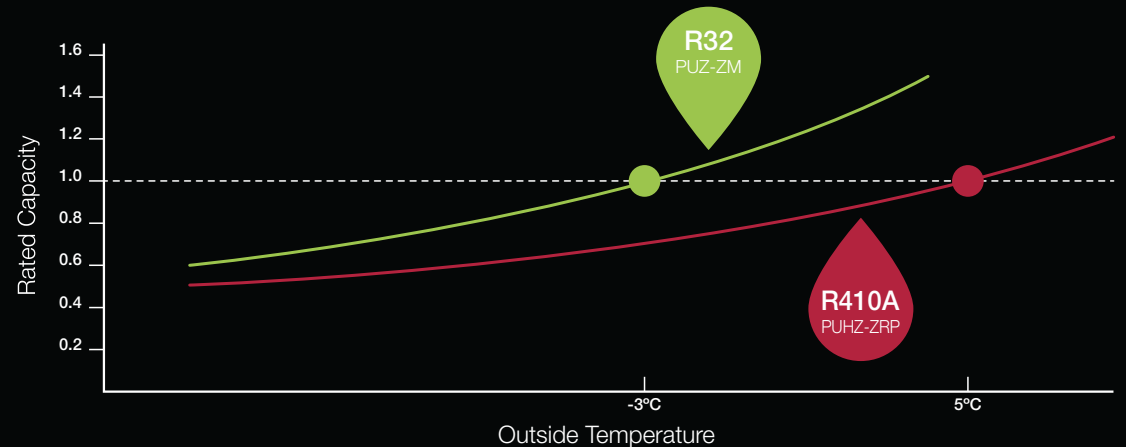

● Multi-Split Applications

The R32 Power Inverter can be used as a Multi-Split, making it an ideal option for open plan spaces in medium sized premises such as shops or offices, where two or three indoor units are required connected to a single outdoor unit. The indoor units can be a mix of ceiling cassettes, wall mounted, ceiling concealed ducted or ceiling suspended types.

Indoor Unit Combination	Outdoor Unit Capacity				
	Twin				Triple
	7.1kW	10.0kW	12.5kW	14.0kW	14.0kW
PLA-ZM	3.5 x 2	5.0 x 2	6.0 x 2	7.1 x 2	5.0 x 3
PKA-M	3.5 x 2	5.0 x 2	6.0 x 2	7.1 x 2	5.0 x 3
PEAD-M	3.5 x 2	5.0 x 2	6.0 x 2	7.1 x 2	5.0 x 3
PCA-M	-	5.0 x 2	6.0 x 2	7.1 x 2	5.0 x 3

Twin Indoor Units

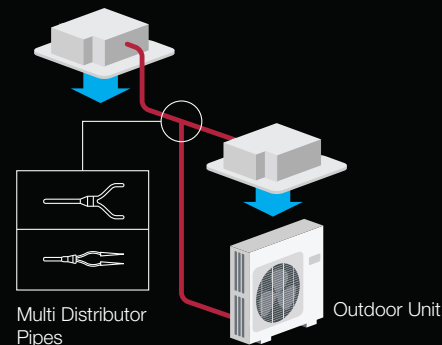

Triple Indoor Units

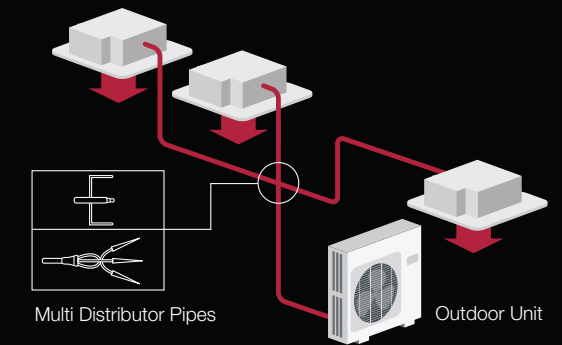

Built using micron-precise calculations, the compressor is the heart of the R32 Power Inverter air conditioning system



Poki-Poki Motor



Dramatically enhanced motor efficiency utilising Mitsubishi Electric's original dense winding technology.

Heat Caulking



Mitsubishi Electric's heat caulking method minimises cylinder distortion for even greater efficiency.

30Pa External Static Pressure

An external static pressure of 30Pa enables the outdoor unit to be installed on balconies in high-rise buildings or spaces near louvres.*

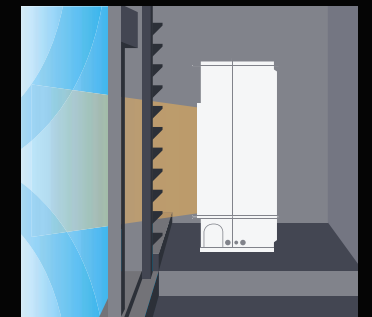

* Optional (requires PAC-SJ71FM-E). Rated noise levels may be higher when equipped with this option.

Solutions that address the ban on R22 refrigerant

As of 1st January 2015 it became illegal to use R22 refrigerant*1 to service and maintain air conditioning units, yet there are a large number of systems still in use in the UK that rely on R22.

Many of these building operators remain unaware that whilst their air conditioning will not be illegal to run, it may need immediate replacement if it requires maintenance involving any degassing of the system.

The continual rise in energy costs also means everyone involved in the built environment is focusing on energy use and consumption and this is where modern equipment can really help to support replacement.

The R32 Power Inverter models incorporate our unique **'Replace Technology'** which allows the upgrade of systems using existing pipe work, without the need to apply any special cleaning machines.

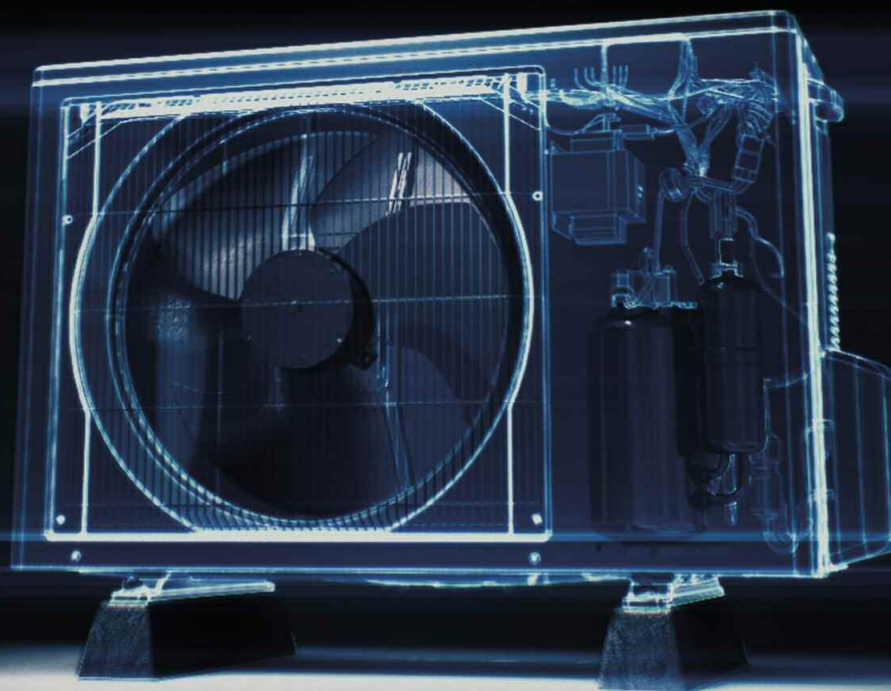

*1 The EC Ozone Regulation (No.1005/2009) was introduced to control and phase out the remaining uses of all Ozone Depleting Substances (ODS) such as R22 refrigerant. This has led to a total ban on its use for service and maintenance by the start of the year 2015. ODS can result in greater UV radiation reaching the earth's surface which is harmful for humans, animals and plants, leading to increases in skin cancer, cataracts and a reduction in food crop yields. Modern alternatives such as HFC's, which include R32, do not have the same ozone depleting potential (ODP).

PLA-ZM 4-Way Blow Ceiling Cassette System



The new square grille design of the **PLA-ZM** beautifully harmonises with any interior, making it ideal for applications such as offices or retail stores.

● Horizontal Airflow Control

New horizontal airflow control helps remove uncomfortable draughts and improve comfort levels.

● Optional 3D i-see Sensor

Highly accurate 360° motion detection for body temperature and room occupancy, improving efficiency and comfort through automatic selection of energy-saving modes.

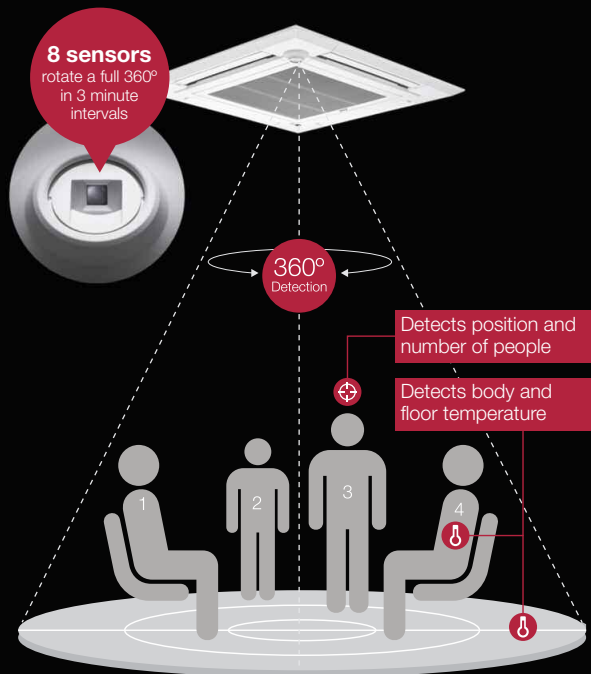

● Optional Filter Lowering Grille

Allows easy, regular cleaning of the filter, improving efficiency and reducing maintenance.

This feature is particularly useful in rooms that have a high ceiling

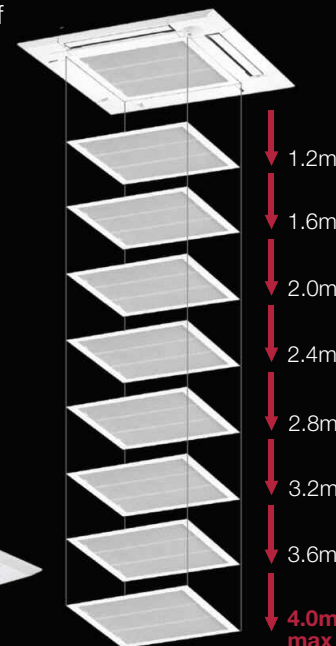

● Controller Options



↑ **PAR-33MAA**
Wired Controller



PAR-SL100A-E →
Backlit Wireless Controller

NEW



PKA-M Wall Mounted System



The **PKA-M** blends a host of outstanding features with a sophisticated pure white, flat panel, streamlined design. Offering high seasonal efficiency, advanced control options and quiet operation, this range provides extreme flexibility and ease of installation.

- Improved airflow control, including adjustable louvres for uniform air distribution
- Internal pipe connection to wall mounted unit for easy and neat installation
- Compact Indoor Units

Indoor unit width has been reduced by as much as 510mm. Units take up much less space, greatly increasing installation possibilities.

PKA-M35/50HA

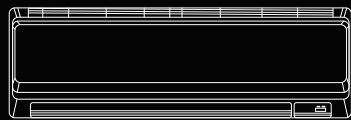

➔ 92mm DOWN* ➔

*Compared to PKA-RP35/50GA

PKA-M60/71KA

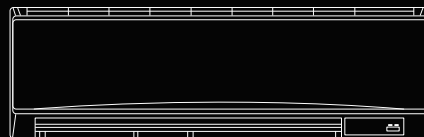

➔ 230mm DOWN* ➔

*Compared to PKA-RP60/71FA

PKA-M100KA

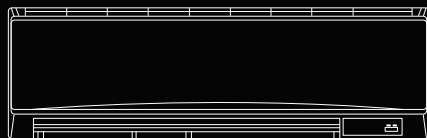

➔ 510mm DOWN* ➔

*Compared to PKA-RP100FA

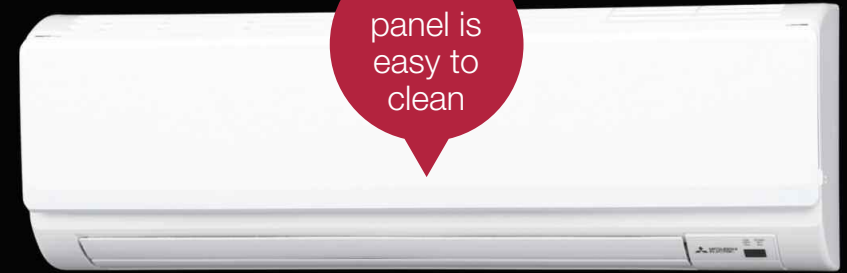

Flat panel is easy to clean



● Controller Options

CN22 connector as standard for connection to PAR-33MAA wired controller



➔ PAR-33MAA
Wired Controller



➔ PAR-FL32MA
Wireless Controller

PEAD-M Ceiling Concealed Ducted System



The **PEAD-M** includes a host of outstanding features with an unobtrusive design for easy installation and maintenance.



● Compact Indoor Units

The height of all models has been unified to 250mm. Compared to the previous PEAD-RP EA range, this has seen a reduction by as much as 75mm (sizes 100-140), making installation in low ceilings with a minimal clearance space possible.



Reduction of
75mm
(models 100-140)
compared to
PEAD-RP EA

● External Static Pressure

The external static pressure can be set to five stages, up to a maximum of 150Pa, making units applicable for a wide range of building types. This is now standard on all unit sizes.

External static pressure setting

Model / Size	35	50	60	71	100	125	140
PEAD-M	35/50/70/100/150Pa						

● Drain pump is included as standard

● PAR-33MAA Wired Controller



PCA-M Ceiling Suspended System



The **PCA-M** incorporates a stylish new indoor unit design with airflow settings for both high and low ceiling applications, expanding the installation possibilities of this unit.

● Stylish Indoor Unit Design

A new stylish square-like design allows these units to blend in seamlessly with the ceiling.



● Automatic Air-speed Adjustment

In addition to the conventional 4-speed setting, units are now equipped with an automatic air-speed adjustment mode. This setting automatically adjusts the air speed to conditions that match the room environment. At the start of the heating/cooling operation, the airflow is set to high-speed to quickly heat/cool the room. When the room temperature reaches the desired setting, the airflow speed is decreased automatically creating a stable, comfortable environment.

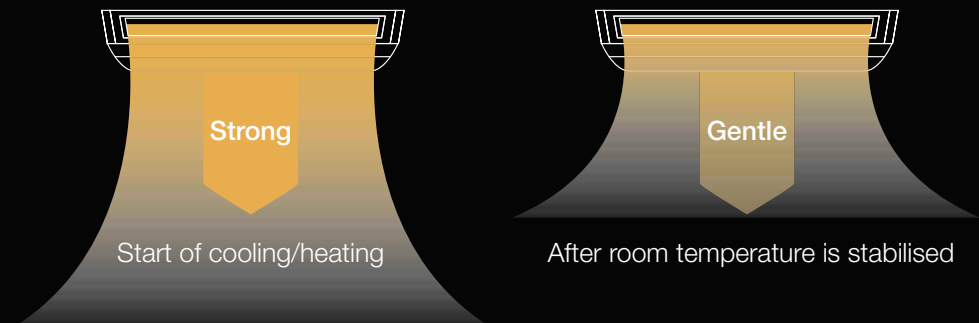

● High / Low Ceiling Modes

Units are equipped with high and low ceiling operation modes that make it possible to switch the airflow volume to match room height. The ability to choose the optimum airflow volume makes it possible to reduce draughts.

Size	High Ceiling	Standard Ceiling	Low Ceiling
50	3.5m	2.7m	2.5m
60	3.5m	2.7m	2.5m
71	3.5m	2.7m	2.5m
100	4.2m	3.0m	2.6m
125	4.2m	3.0m	2.6m
140	4.2m	3.0m	2.6m

● Optional Drain Pump

The pumping height of the optional drain pump has been increased from 400mm to 600mm, expanding the location possibilities of the unit.

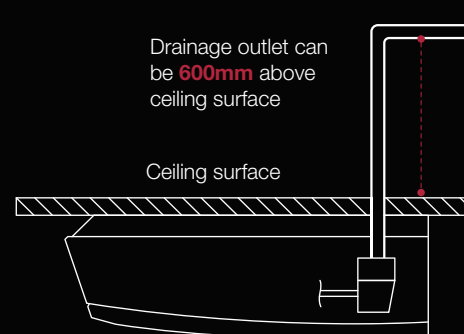

● Controller Options



↑ **PAR-33MAA**
Wired Controller

↑ **PAR-SL94B**
Wireless Controller and receiver

● Outside air Intake

Units are equipped with a knock-out hole that enables the induction of fresh air.

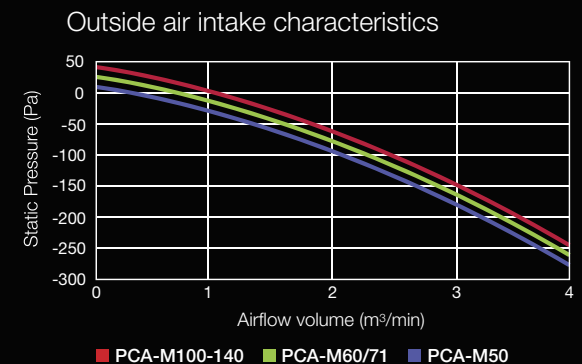



Mobile control and monitoring of your Mitsubishi Electric systems

MELCloud is a cloud based solution for controlling and monitoring your Mitsubishi Electric air conditioning, ventilation or heating systems either locally or remotely by PC, tablet or smartphone app.

It offers the ability to control which units are on/off, temperature settings, the 7 day weekly schedule, frost protection settings, holiday mode and also log and record errors.

Ensuring total flexibility from a single device, from any worldwide location, the MELCloud app also provides localised information like weather forecasts and customer service contact details.

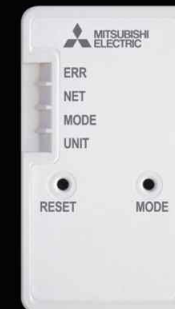

↑ **MAC-567IF**
Optional Wi-Fi Interface



PLA-ZM R32 Power Inverter Heat Pump

4-Way Blow Ceiling Cassette System

Product Specifications



Mr.SLM™

R32



PLA-ZM - INDOOR UNITS		PLA-ZM35EA	PLA-ZM50EA	PLA-ZM60EA	PLA-ZM71EA	PLA-ZM100EA	PLA-ZM100EA	PLA-ZM125EA	PLA-ZM125EA	PLA-ZM140EA	PLA-ZM140EA
CAPACITY (kW)	Heating (nominal)	4.1 (1.6-5.2)	6.0 (2.5-7.3)	7.0 (2.8-8.2)	8.0 (3.5-10.2)	11.2 (4.5-14.0)	11.2 (4.5-14.0)	14.0 (5.0-16.0)	14.0 (5.0-16.0)	16.0 (5.7-18.0)	16.0 (5.7-18.0)
	Cooling (nominal)	3.6 (1.6-4.5)	5.0 (2.3-5.6)	6.1 (2.7-6.5)	7.1 (3.3-8.1)	9.5 (4.9-11.4)	9.5 (4.9-11.4)	12.5 (5.5-14.0)	12.5 (5.5-14.0)	13.4 (6.2-15.0)	13.4 (6.2-15.0)
	Heating (UK)	3.5 (1.35-4.4)	5.1 (2.15-6.2)	6.0 (2.38-6.97)	6.8 (3.0-8.65)	9.5 (3.85-11.9)	9.5 (3.85-11.9)	11.9 (4.25-13.6)	11.9 (4.25-13.6)	13.6 (4.85-15.3)	13.6 (4.85-15.3)
	Cooling (UK)	3.3 (1.45-4.15)	4.6 (2.1-5.15)	5.6 (2.48-5.98)	6.55 (3.05-7.45)	9.2 (4.5-10.5)	9.2 (4.5-10.5)	11.5 (5.05-12.9)	11.5 (5.05-12.9)	12.9 (5.7-14.1)	12.9 (5.7-14.1)
SHF (nominal)		0.95	0.85	0.77	0.72	0.77	0.77	0.70	0.70	0.70	0.70
COP / EER (nominal)		5.00 / 5.10	4.40 / 4.52	4.10 / 4.20	4.40 / 4.30	4.30 / 4.60	4.30 / 4.60	3.81 / 3.70	3.81 / 3.70	3.71 / 3.60	3.71 / 3.60
SCOP / SEER (BS EN14825)		4.70 / 7.50	4.90 / 7.60	4.60 / 7.20	4.80 / 7.60	4.80 / 7.70	4.80 / 7.50	4.70 / 7.40	4.70 / 7.20	4.60 / 7.00	4.60 / 6.90
ERP ENERGY EFFICIENCY CLASS	Heating/Cooling	A++ / A++	A++ / A++	A++ / A++	A++ / A++	A++ / A++	A++ / A++	A++ / A++	A++ / A++	A++ / A++	A++ / A++
AIRFLOW (l/s)	Lo-Mi-Mi2-Hi	183-217-250-267	200-233-267-300	200-233-267-300	283-317-350-383	317-367-417-467	317-367-417-467	350-400-433-483	350-400-433-483	400-433-483-533	400-433-483-533
PIPE SIZE MM (in)	Gas/Liquid	12.7 (1/2") / 6.35 (1/4")	12.7 (1/2") / 6.35 (1/4")	15.88 (5/8") / 9.52 (3/8")	15.88 (5/8") / 9.52 (3/8")	15.88 (5/8") / 9.52 (3/8")	15.88 (5/8") / 9.52 (3/8")	15.88 (5/8") / 9.52 (3/8")	15.88 (5/8") / 9.52 (3/8")	15.88 (5/8") / 9.52 (3/8")	15.88 (5/8") / 9.52 (3/8")
SOUND PRESSURE LEVEL (dBA)	Lo-Mi-Mi2-Hi	26-28-29-31	27-29-31-32	27-29-31-32	28-30-33-36	31-34-37-40	31-34-37-40	33-36-39-41	33-36-39-41	36-39-42-44	36-39-42-44
SOUND POWER LEVEL (dBA)		51	54	54	57	61	61	62	62	65	65
DIMENSIONS (mm)	Width x Depth x Height (Grille)	840 (950) x 840 (950) x 258 (40)	840 (950) x 840 (950) x 258 (40)	840 (950) x 840 (950) x 258 (40)	840 (950) x 840 (950) x 298 (40)	840 (950) x 840 (950) x 298 (40)	840 (950) x 840 (950) x 298 (40)	840 (950) x 840 (950) x 298 (40)	840 (950) x 840 (950) x 298 (40)	840 (950) x 840 (950) x 298 (40)	840 (950) x 840 (950) x 298 (40)
WEIGHT (kg)	Unit / Grille	21 / 5	21 / 5	21 / 5	24 / 5	26 / 5	26 / 5	26 / 5	26 / 5	26 / 5	26 / 5
ELECTRICAL SUPPLY		Fed by Outdoor Unit	Fed by Outdoor Unit	Fed by Outdoor Unit	Fed by Outdoor Unit	Fed by Outdoor Unit	Fed by Outdoor Unit	Fed by Outdoor Unit	Fed by Outdoor Unit	Fed by Outdoor Unit	Fed by Outdoor Unit
FUSE RATING (BS88) - HRC (A)		6	6	6	6	6	6	6	6	6	6
INTERCONNECTING CABLE NO. CORES		4	4	4	4	4	4	4	4	4	4
GRILLE REFERENCE		PLP-6EA	PLP-6EA	PLP-6EA	PLP-6EA	PLP-6EA	PLP-6EA	PLP-6EA	PLP-6EA	PLP-6EA	PLP-6EA
WIRED REMOTE CONTROLLER REFERENCE		PAR-33MAA	PAR-33MAA	PAR-33MAA	PAR-33MAA	PAR-33MAA	PAR-33MAA	PAR-33MAA	PAR-33MAA	PAR-33MAA	PAR-33MAA
WIRELESS REMOTE CONTROLLER REFERENCE		PAR-SL100A-E	PAR-SL100A-E	PAR-SL100A-E	PAR-SL100A-E	PAR-SL100A-E	PAR-SL100A-E	PAR-SL100A-E	PAR-SL100A-E	PAR-SL100A-E	PAR-SL100A-E

PUZ-ZM - OUTDOOR UNITS		PUZ-ZM35VKA	PUZ-ZM50VKA	PUZ-ZM60VHA	PUZ-ZM71VHA	PUZ-ZM100VKA	PUZ-ZM100YKA ⁽³⁾	PUZ-ZM125VKA	PUZ-ZM125YKA ⁽³⁾	PUZ-ZM140VKA	PUZ-ZM140YKA ⁽³⁾
SOUND PRESSURE LEVEL (dBA)	Heating/Cooling	46 / 44	46 / 44	49 / 47	49 / 47	51 / 49	51 / 49	52 / 50	52 / 50	52 / 50	52 / 50
	Cooling	65	65	67	67	69	69	70	70	70	70
SOUND POWER LEVEL (dBA)		46	46	70	70	116	123	116	125	118	131
WEIGHT (kg)		809 x 300 x 630	809 x 300 x 630	950 x 330 + 25 x 943	950 x 330 + 25 x 943	1050 x 330 + 40 x 1338	1050 x 330 + 40 x 1338	1050 x 330 + 40 x 1338	1050 x 330 + 40 x 1338	1050 x 330 + 40 x 1338	1050 x 330 + 40 x 1338
DIMENSIONS (mm)	Width x Depth x Height	809 x 300 x 630	809 x 300 x 630	950 x 330 + 25 x 943	950 x 330 + 25 x 943	1050 x 330 + 40 x 1338	1050 x 330 + 40 x 1338	1050 x 330 + 40 x 1338	1050 x 330 + 40 x 1338	1050 x 330 + 40 x 1338	1050 x 330 + 40 x 1338
ELECTRICAL SUPPLY		220-240v, 50Hz	220-240v, 50Hz	220-240v, 50Hz	220-240v, 50Hz	220-240v, 50Hz	380-415v, 50Hz	220-240v, 50Hz	380-415v, 50Hz	220-240v, 50Hz	380-415v, 50Hz
PHASE		Single	Single	Single	Single	Single	Three	Single	Three	Single	Three
SYSTEM POWER INPUT (kW)	Heating/Cooling (nominal)	0.820 / 0.705	1.363 / 1.106	1.707 / 1.452	1.818 / 1.651	2.604 / 2.065	2.604 / 2.065	3.674 / 3.378	3.674 / 3.378	4.312 / 3.772	4.312 / 3.772
	Heating/Cooling (UK)	0.73 / 0.59	1.21 / 0.94	1.43 / 1.15	1.61 / 1.39	2.09 / 1.77	2.09 / 1.77	3.27 / 2.87	3.27 / 2.87	3.83 / 3.15	3.83 / 3.15
STARTING CURRENT (A)		5.0	5.0	6.0	6.0	13.0	6.0	13.0	6.0	13.0	6.0
SYSTEM RUNNING CURRENT (A)	Heating/Cooling [MAX]	3.89 / 3.51 [13.2]	6.05 / 5.00 [13.2]	7.39 / 6.31 [19.2]	7.79 / 7.06 [19.3]	11.25 / 8.97 [27.0]	3.75 / 2.96 [8.5]	15.77 / 14.53 [27.0]	5.32 / 4.89 [10.0]	18.41 / 15.88 [28.7]	6.23 / 5.37 [13.7]
FUSE RATING (BS88) - HRC (A)		16	16	25	25	32	16	32	16	40	16
MAINS CABLE NO. CORES		3	3	3	3	3	5	3	5	3	5
MAX PIPE LENGTH (m)		50	50	55	55	100	100	100	100	100	100
MAX HEIGHT DIFFERENCE (m)		30	30	30	30	30	30	30	30	30	30
CHARGE REFRIGERANT (kg) / CO ₂ EQUIVALENT (t)	R32 (GWP 675) - 30m	2.0 / 1.35	2.00 / 1.35	2.80 / 1.89	2.80 / 1.89	4.00 / 2.70	4.00 / 2.70	4.00 / 2.70	4.00 / 2.70	4.00 / 2.70	4.00 / 2.70
MAX ADDITIONAL REFRIGERANT (kg) / CO ₂ EQUIVALENT (t)	R32 (GWP 675)	0.30 / 0.20	0.30 / 0.20	0.80 / 0.54	0.80 / 0.54	2.80 / 1.89	2.80 / 1.89	2.80 / 1.89	2.80 / 1.89	2.80 / 1.89	2.80 / 1.89

³ Three Phase

Product Dimensions PLA-ZM35-140EA

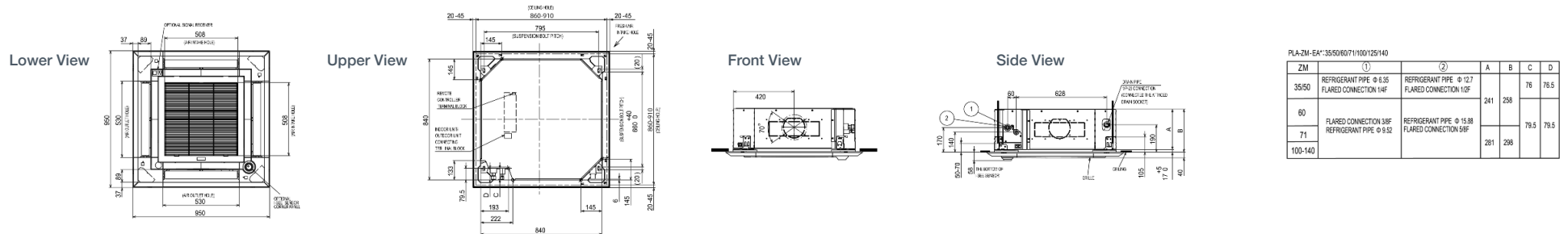

PLA-ZM-EA*35506071100125140						
ZM	①	②	A	B	C	D
35/50	REFRIGERANT PIPE Ø 6.35 FLARED CONNECTION 14F	REFRIGERANT PIPE Ø 12.7 FLARED CONNECTION 10F				
60			241	258		76 76.5
71	FLARED CONNECTION 38F REFRIGERANT PIPE Ø 9.52	REFRIGERANT PIPE Ø 15.88 FLARED CONNECTION 58F				76.5 79.5
100-140			281	298		

PKA-M R32 Power Inverter Heat Pump

Wall Mounted System

Product Specifications



R32



PKA-M - INDOOR UNITS		PKA-M35HA	PKA-M50HA	PKA-M60KA	PKA-M71KA	PKA-M100KA	PKA-M100KA
CAPACITY (kW)	Heating (nominal)	4.1 (1.6-5.2)	5.0 (2.5-7.3)	7.0 (2.8-8.2)	8.0 (3.5-10.2)	11.2 (4.5-14.0)	11.2 (4.5-14.0)
	Cooling (nominal)	3.6 (1.6-4.5)	4.6 (2.3-5.6)	6.1 (2.7-6.7)	7.1 (3.3-8.1)	9.5 (4.9-11.4)	9.5 (4.9-11.4)
	Heating (UK)	3.5 (1.35-4.4)	4.25 (2.15-6.2)	5.95 (2.4-6.95)	6.8 (3.0-8.65)	9.5 (3.85-11.9)	9.5 (3.85-11.9)
	Cooling (UK)	3.3 (1.45-4.15)	4.23 (2.1-5.15)	5.5 (2.5-6.15)	6.55 (3.05-7.45)	9.2 (4.5-10.5)	9.2 (4.5-10.5)
SHF (nominal)		0.81	0.72	0.86	0.78	0.73	0.73
COP / EER (nominal)		3.94 / 4.14	3.71 / 3.71	4.04 / 3.91	3.78 / 3.81	3.61 / 3.95	3.61 / 3.95
SCOP / SEER (BS EN14825)		4.0 / 6.3	4.1 / 6.4	4.2 / 6.8	4.3 / 6.8	4.4 / 6.5	4.4 / 6.4
ERP ENERGY EFFICIENCY CLASS	Heating/Cooling	A+ / A++	A+ / A++	A+ / A++	A+ / A++	A+ / A++	A+ / A++
AIRFLOW (l/s)	Lo-Mi-Hi	150-175-200	150-175-200	300-333-367	300-333-367	333-383-433	333-383-433
PIPE SIZE MM (in)	Gas	12.7 (1/2")	12.7 (1/2")	15.88 (5/8")	15.88 (5/8")	15.88 (5/8")	15.88 (5/8")
	Liquid	6.35 (1/4")	6.35 (1/4")	9.52 (3/8")	9.52 (3/8")	9.52 (3/8")	9.52 (3/8")
SOUND PRESSURE LEVEL (dBA)	Lo-Mi-Hi	36-40-43	36-40-43	39-42-45	39-42-45	41-45-49	41-45-49
SOUND POWER LEVEL (dBA)		60	60	64	64	65	65
DIMENSIONS (mm)	Width x Depth x Height	898 x 249 x 295	898 x 249 x 295	1170 x 295 x 365	1170 x 295 x 365	1170 x 295 x 365	1170 x 295 x 365
WEIGHT (kg)		13	13	21	21	21	21
ELECTRICAL SUPPLY		Fed by Outdoor Unit	Fed by Outdoor Unit	Fed by Outdoor Unit	Fed by Outdoor Unit	Fed by Outdoor Unit	Fed by Outdoor Unit
FUSE RATING (BS88) - HRC (A)		6	6	6	6	6	6
INTERCONNECTING CABLE NO. CORES		4	4	4	4	4	4
WIRED REMOTE CONTROLLER REFERENCE		PAR-33MAA	PAR-33MAA	PAR-33MAA	PAR-33MAA	PAR-33MAA	PAR-33MAA
WIRELESS REMOTE CONTROLLER REFERENCE		PAR-FL32MA	PAR-FL32MA	PAR-FL32MA	PAR-FL32MA	PAR-FL32MA	PAR-FL32MA

PUZ-ZM - OUTDOOR UNITS		PUZ-ZM35VKA	PUZ-ZM50VKA	PUZ-ZM60VHA	PUZ-ZM71VHA	PUZ-ZM100VKA	PUZ-ZM100YKA ³
SOUND PRESSURE LEVEL (dBA)	Heating/Cooling	46 / 44	46 / 44	49 / 47	49 / 47	51 / 49	51 / 49
SOUND POWER LEVEL (dBA)	Cooling	65	65	67	67	69	69
WEIGHT (kg)		46	46	70	70	116	123
DIMENSIONS (mm)	Width x Depth x Height	809 x 300 x 630	809 x 300 x 630	950 x 330 + 25 x 943	950 x 330 + 25 x 943	1050 x 330 + 40 x 1338	1050 x 330 + 40 x 1338
ELECTRICAL SUPPLY		220-240v, 50Hz	220-240v, 50Hz	220-240v, 50Hz	220-240v, 50Hz	220-240v, 50Hz	380-415v, 50Hz
PHASE		Single	Single	Single	Single	Single	Three
SYSTEM POWER INPUT (kW)	Heating/Cooling (nominal)	1.040 / 0.869	1.347 / 1.239	1.732 / 1.560	2.116 / 1.863	3.102 / 2.405	3.102 / 2.405
	Heating/Cooling (UK)	0.81 / 0.84	1.12 / 1.12	1.25 / 1.65	1.54 / 1.92	2.47 / 2.06	2.47 / 2.06
STARTING CURRENT (A)		5.0	5.0	6.0	6.0	13.0	6.0
SYSTEM RUNNING CURRENT (A)	Heating/Cooling [MAX]	4.97 / 4.31 [13.4]	5.98 / 5.57 [13.4]	7.41 / 6.65 [19.4]	9.10 / 7.96 [19.4]	13.46 / 10.45 [27.1]	4.49 / 5.45 [8.6]
FUSE RATING (BS88) - HRC (A)		16	16	25	25	32	16
MAINS CABLE NO. CORES		3	3	3	3	3	5
MAX PIPE LENGTH (m)		50	50	55	55	100	100
MAX HEIGHT DIFFERENCE (m)		30	30	30	30	30	30
CHARGE REFRIGERANT (kg) / CO ₂ EQUIVALENT (t)	R32 (GWP 675) - 30m	2.0 / 1.35	2.00 / 1.35	2.80 / 1.89	2.80 / 1.89	4.00 / 2.70	4.00 / 2.70
MAX ADDITIONAL REFRIGERANT (kg) / CO ₂ EQUIVALENT (t)	R32 (GWP 675)	0.30 / 0.20	0.30 / 0.20	0.80 / 0.54	0.80 / 0.54	2.80 / 1.89	2.80 / 1.89

³ Three Phase

Product Dimensions PKA-M35/50HA

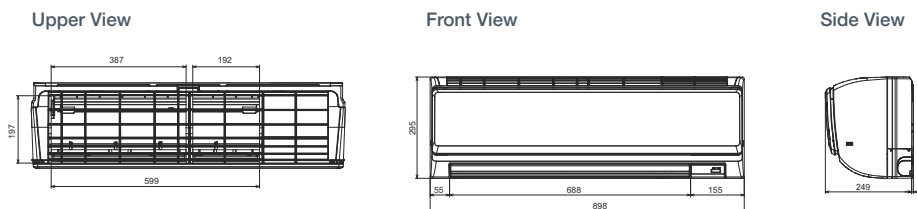

Product Dimensions PKA-M60/71/100KA

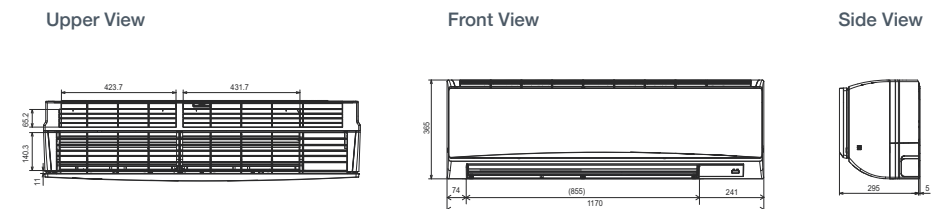

PEAD-M R32 Power Inverter Heat Pump

Ceiling Concealed Ducted System

Product Specifications



Mr.SLM

R32



PEAD-M - INDOOR UNITS		PEAD-M35JA	PEAD-M50JA	PEAD-M60JA	PEAD-M71JA	PEAD-M100JA	PEAD-M100JA	PEAD-M125JA	PEAD-M125JA	PEAD-M140JA	PEAD-M140JA
CAPACITY (kW)	Heating (nominal)	4.1 (1.6-5.2)	6.0 (2.5-7.3)	7.0 (2.8-8.2)	8.0 (3.5-10.2)	11.2 (4.5-14.0)	11.2 (4.5-14.0)	14.0 (5.0-16.0)	14.0 (5.0-16.0)	16.0 (5.7-18.0)	16.0 (5.7-18.0)
	Cooling (nominal)	3.6 (1.6-4.5)	5.0 (2.3-5.6)	6.1 (2.7-6.7)	7.1 (3.3-8.1)	9.5 (4.9-11.4)	9.5 (4.9-11.4)	12.5 (5.5-14.0)	12.5 (5.5-14.0)	13.4 (6.2-15.3)	13.4 (6.2-15.3)
	Heating (UK)	3.5 (1.35-4.4)	5.1 (2.15-6.2)	5.95 (2.4-6.95)	6.8 (3.0-8.65)	9.5 (3.85-11.9)	9.5 (3.85-11.9)	11.9 (4.25-13.6)	11.9 (4.25-13.6)	13.6 (4.85-15.3)	13.6 (4.85-15.3)
	Cooling (UK)	3.3 (1.45-4.15)	4.6 (2.1-5.15)	5.5 (2.5-6.15)	6.55 (3.05-7.45)	9.2 (4.5-10.5)	9.2 (4.5-10.5)	11.5 (5.05-12.9)	11.5 (5.05-12.9)	12.9 (5.7-14.1)	12.9 (5.7-14.1)
SHF (nominal)		0.85	0.84	0.83	0.83	0.82	0.82	0.84	0.84	0.84	0.84
COP / EER (nominal)		4.47 / 4.30	4.57 / 4.16	4.33 / 4.04	4.14 / 3.82	4.31 / 4.18	4.31 / 4.18	4.18 / 3.75	4.18 / 3.75	4.03 / 3.69	4.03 / 3.69
SCOP / SEER (BS EN14825)		3.9 / 5.8	4.3 / 6.2	4.0 / 6.1	3.9 / 5.8	4.1 / 6.2	4.1 / 6.1	3.9 / 5.8	3.9 / 5.7	4.0 / 5.7	4.0 / 5.6
ERP ENERGY EFFICIENCY CLASS	Heating/Cooling	A / A+	A+ / A++	A+ / A++	A / A+	A+ / A++	A+ / A++	A / A+	A / A+	A+ / A+	A+ / A+
AIRFLOW (l/s)	Lo-Mi-Hi	167-200-233	200-242-283	242-300-350	292-350-417	400-483-567	400-483-567	492-592-700	492-592-700	533-650-767	533-650-767
PIPE SIZE MM (in)	Gas	12.7 (1/2")	12.7 (1/2")	15.88 (5/8")	15.88 (5/8")	15.88 (5/8")	15.88 (5/8")	15.88 (5/8")	15.88 (5/8")	15.88 (5/8")	15.88 (5/8")
	Liquid	6.35 (1/4")	6.35 (1/4")	9.52 (3/8")	9.52 (3/8")	9.52 (3/8")	9.52 (3/8")	9.52 (3/8")	9.52 (3/8")	9.52 (3/8")	9.52 (3/8")
EXTERNAL STATIC PRESSURE (Pa)		35-50-70-100-150	35-50-70-100-150	35-50-70-100-150	35-50-70-100-150	35-50-70-100-150	35-50-70-100-150	35-50-70-100-150	35-50-70-100-150	35-50-70-100-150	35-50-70-100-150
SOUND PRESSURE LEVEL (dBA)	Lo-Mi-Hi	23-27-30	26-31-35	25-29-33	26-30-34	29-34-38	29-34-38	33-36-40	33-36-40	34-38-43	34-38-43
SOUND POWER LEVEL (dBA)		54	59	55	58	62	62	66	66	67	67
DIMENSIONS (mm)	Width x Depth x Height	900 x 732 x 250	900 x 732 x 250	1100 x 732 x 250	1100 x 732 x 250	1400 x 732 x 250	1400 x 732 x 250	1400 x 732 x 250	1400 x 732 x 250	1600 x 732 x 250	1600 x 732 x 250
WEIGHT (kg)		26	27	30	30	39	39	40	40	44	44
ELECTRICAL SUPPLY		Fed by Outdoor Unit	Fed by Outdoor Unit	Fed by Outdoor Unit	Fed by Outdoor Unit	Fed by Outdoor Unit	Fed by Outdoor Unit	Fed by Outdoor Unit	Fed by Outdoor Unit	Fed by Outdoor Unit	Fed by Outdoor Unit
FUSE RATING (BS88) - HRC (A)		6	6	6	6	6	6	6	6	6	6
INTERCONNECTING CABLE NO. CORES		4	4	4	4	4	4	4	4	4	4
WIRED REMOTE CONTROLLER REFERENCE		PAR-33MAA	PAR-33MAA	PAR-33MAA	PAR-33MAA	PAR-33MAA	PAR-33MAA	PAR-33MAA	PAR-33MAA	PAR-33MAA	PAR-33MAA
PUZ-ZM - OUTDOOR UNITS		PUZ-ZM35VKA	PUZ-ZM50VKA	PUZ-ZM60VHA	PUZ-ZM71VHA	PUZ-ZM100VKA	PUZ-ZM100YKA ³	PUZ-ZM125VKA	PUZ-ZM125YKA ³	PUZ-ZM140VKA	PUZ-ZM140YKA ³
SOUND PRESSURE LEVEL (dBA)	Heating/Cooling	46 / 44	46 / 44	49 / 47	49 / 47	51 / 49	51 / 49	52 / 50	52 / 50	52 / 50	52 / 50
SOUND POWER LEVEL (dBA)	Cooling	65	65	67	67	69	69	70	70	70	70
WEIGHT (kg)		46	46	70	70	116	123	116	125	118	131
DIMENSIONS (mm)	Width x Depth x Height	809 x 300 x 630	809 x 300 x 630	950 x 330 + 25 x 943	950 x 330 + 25 x 943	1050 x 330 + 40 x 1338	1050 x 330 + 40 x 1338	1050 x 330 + 40 x 1338	1050 x 330 + 40 x 1338	1050 x 330 + 40 x 1338	1050 x 330 + 40 x 1338
ELECTRICAL SUPPLY		220-240v, 50Hz	220-240v, 50Hz	220-240v, 50Hz	220-240v, 50Hz	220-240v, 50Hz	380-415v,50Hz	220-240v, 50Hz	380-415v,50Hz	220-240v, 50Hz	380-415v,50Hz
PHASE		Single	Single	Single	Single	Single	Three	Single	Three	Single	Three
SYSTEM POWER INPUT (kW)	Heating/Cooling (nominal)	0.917 / 0.837	1.312 / 1.201	1.616 / 1.509	1.932 / 1.858	2.598 / 2.272	2.598 / 2.272	3.349 / 3.333	3.349 / 3.333	3.970 / 3.631	3.970 / 3.631
	Heating/Cooling (UK)	0.76 / 0.76	1.11 / 1.06	1.32 / 1.39	1.7 / 1.59	2.07 / 1.95	2.07 / 1.95	2.68 / 2.86	2.68 / 2.86	3.16 / 3.11	3.16 / 3.11
STARTING CURRENT (A)		5.0	5.0	6.0	6.0	13.0	6.0	13.0	6.0	13.0	6.0
SYSTEM RUNNING CURRENT (A)	Heating/Cooling [MAX]	4.17 / 3.89 [4.1]	5.55 / 5.07 [14.4]	6.68 / 6.16 [20.5]	7.85 / 7.45 [21]	10.54 / 9.07 [29.2]	3.51 / 3.01 [10.7]	13.21 / 13.10 [29.3]	4.45 / 4.41 [12.3]	15.74 / 14.21 [30.8]	5.58 / 4.87 [15.8]
FUSE RATING (BS88) - HRC (A)		16	16	25	25	32	16	32	16	40	16
MAINS CABLE NO. CORES		3	3	3	3	3	5	3	5	3	5
MAX PIPE LENGTH (m)		50	50	55	55	100	100	100	100	100	100
MAX HEIGHT DIFFERENCE (m)		30	30	30	30	30	30	30	30	30	30
CHARGE REFRIGERANT (kg) / CO ₂ EQUIVALENT (t)	R32 (GWP 675) - 30m	2.0 / 1.35	2.00 / 1.35	2.80 / 1.89	2.80 / 1.89	4.00 / 2.70	4.00 / 2.70	4.00 / 2.70	4.00 / 2.70	4.00 / 2.70	4.00 / 2.70
MAX ADDITIONAL REFRIGERANT (kg) / CO ₂ EQUIVALENT (t)	R32 (GWP 675)	0.30 / 0.20	0.30 / 0.20	0.80 / 0.54	0.80 / 0.54	2.80 / 1.89	2.80 / 1.89	2.80 / 1.89	2.80 / 1.89	2.80 / 1.89	2.80 / 1.89

³ Three Phase

Product Dimensions PEAD-M35-140JA

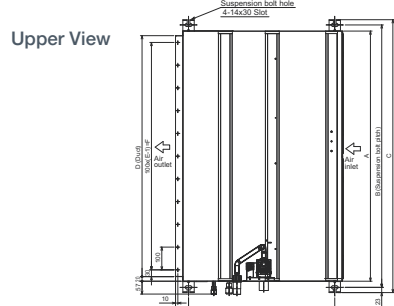
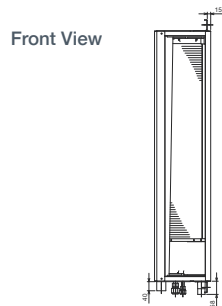

Side View

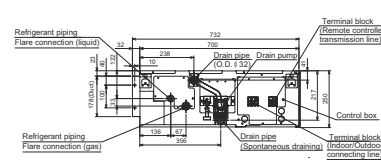

Model	A	B	C	D	E	F
PEAD-M35,50JA	900	954	1000	860	9	800
PEAD-M60,71JA	1100	1154	1200	1060	11	1000
PEAD-M100,125JA	1400	1454	1500	1360	14	1300
PEAD-M140JA	1600	1654	1700	1560	16	1500

PCA-M R32 Power Inverter Heat Pump

Ceiling Suspended System

Product Specifications



PCA-M - INDOOR UNITS		PCA-M50KA	PCA-M60KA	PCA-M71KA	PCA-M100KA	PCA-M100KA	PCA-M125KA	PCA-M125KA	PCA-M140KA	PCA-M140KA
CAPACITY (kW)	Heating (nominal)	5.5 (2.5-6.6)	7.0 (2.8-8.2)	8.0 (3.5-10.2)	11.2 (4.5-14.0)	11.2 (4.5-14.0)	14.0 (5.0-16.0)	14.0 (5.0-16.0)	16.0 (5.7-18.0)	16.0 (5.7-18.0)
	Cooling (nominal)	5.0 (2.3-5.6)	6.1 (2.7-6.7)	7.1 (3.3-8.1)	9.5 (4.9-11.4)	9.5 (4.9-11.4)	12.5 (5.5-14.0)	12.5 (5.5-14.0)	13.4 (6.2-15.0)	13.4 (6.2-15.0)
	Heating (UK)	4.7 (2.15-5.6)	5.95 (2.4-6.95)	6.8 (3.0-8.65)	9.5 (3.85-11.9)	9.5 (3.85-11.9)	11.9 (4.25-13.6)	11.9 (4.25-13.6)	13.6 (4.85-15.3)	13.6 (4.85-15.3)
	Cooling (UK)	4.6 (2.1-5.15)	5.5 (2.5-6.15)	6.55 (3.05-7.45)	9.2 (4.5-10.5)	9.2 (4.5-10.5)	11.5 (5.05-12.9)	11.5 (5.05-12.9)	12.9 (5.7-13.8)	12.9 (5.7-13.8)
SHF (nominal)		0.79	0.81	0.76	0.77	0.77	0.72	0.72	0.72	0.72
COP / EER (nominal)		4.04 / 4.00	4.01 / 4.01	3.71 / 3.88	3.71 / 4.10	3.71 / 4.10	3.54 / 3.25	3.54 / 3.25	3.61 / 3.40	3.61 / 3.40
SCOP / SEER (BS EN14825)		4.2 / 6.7	4.1 / 6.5	4.2 / 6.7	4.3 / 6.4	4.3 / 6.3	4.3 / 6.2	4.3 / 6.1	4.4 / 6.2	4.4 / 6.1
ERP ENERGY EFFICIENCY CLASS	Heating/Cooling	A+ / A++	A+ / A++	A+ / A++	A+ / A++	A+ / A++	A+ / A++	A+ / A++	A+ / A++	A+ / A++
AIRFLOW (l/s)	Lo-Mi1-Mi2-Hi	167-183-217-250	250-267-283-317	267-283-300-333	367-400-433-467	367-400-433-467	383-417-450-483	383-417-450-483	400-433-483-533	400-433-483-533
PIPE SIZE MM (in)	Gas/Liquid	12.7 (1/2") / 6.35 (1/4")	15.88 (5/8") / 9.52 (3/8")	15.88 (5/8") / 9.52 (3/8")	15.88 (5/8") / 9.52 (3/8")	15.88 (5/8") / 9.52 (3/8")	15.88 (5/8") / 9.52 (3/8")	15.88 (5/8") / 9.52 (3/8")	15.88 (5/8") / 9.52 (3/8")	15.88 (5/8") / 9.52 (3/8")
SOUND PRESSURE LEVEL (dBA)	Lo-Mi1-Mi2-Hi	32-34-37-40	33-35-37-40	35-37-39-41	37-39-41-43	37-39-41-43	39-41-43-45	39-41-43-45	41-43-45-48	41-43-45-48
SOUND POWER LEVEL (dBA)		60	60	62	63	63	65	65	68	68
DIMENSIONS (mm)	Width x Depth x Height	960 x 680 x 230	1280 x 680 x 230	1280 x 680 x 230	1600 x 680 x 230	1600 x 680 x 230	1600 x 680 x 230	1600 x 680 x 230	1600 x 680 x 230	1600 x 680 x 230
WEIGHT (kg)		26	32	32	37	37	38	38	40	40
ELECTRICAL SUPPLY		Fed by Outdoor Unit	Fed by Outdoor Unit	Fed by Outdoor Unit	Fed by Outdoor Unit	Fed by Outdoor Unit	Fed by Outdoor Unit	Fed by Outdoor Unit	Fed by Outdoor Unit	Fed by Outdoor Unit
FUSE RATING (BS88) - HRC (A)		6	6	6	6	6	6	6	6	6
INTERCONNECTING CABLE	No. Cores	4	4	4	4	4	4	4	4	4
WIRED REMOTE CONTROLLER REFERENCE		PAR-33MAA	PAR-33MAA	PAR-33MAA	PAR-33MAA	PAR-33MAA	PAR-33MAA	PAR-33MAA	PAR-33MAA	PAR-33MAA
WIRELESS REMOTE CONTROLLER REFERENCE		PAR-SL94B	PAR-SL94B	PAR-SL94B	PAR-SL94B	PAR-SL94B	PAR-SL94B	PAR-SL94B	PAR-SL94B	PAR-SL94B

PUZ-ZM - OUTDOOR UNITS		PUZ-ZM50VKA	PUZ-ZM60VHA	PUZ-ZM71VHA	PUZ-ZM100VKA	PUZ-ZM100YKA ³	PUZ-ZM125VKA	PUZ-ZM125YKA ³	PUZ-ZM140VKA	PUZ-ZM140YKA ³
SOUND PRESSURE LEVEL (dBA)	Heating/Cooling	46 / 44	49 / 47	49 / 47	51 / 49	51 / 49	52 / 50	52 / 50	52 / 50	52 / 50
SOUND POWER LEVEL (dBA)	Cooling	65	67	67	69	69	70	70	70	70
WEIGHT (kg)		46	70	70	116	123	116	125	118	131
DIMENSIONS (mm)	Width x Depth x Height	809 x 300 x 630	950 x 330 + 25 x 943	950 x 330 + 25 x 943	1050 x 330 + 40 x 1338	1050 x 330 + 40 x 1338	1050 x 330 + 40 x 1338	1050 x 330 + 40 x 1338	1050 x 330 + 40 x 1338	1050 x 330 + 40 x 1338
ELECTRICAL SUPPLY		220-240v, 50Hz	220-240v, 50Hz	220-240v, 50Hz	220-240v, 50Hz	380-415v,50Hz	220-240v, 50Hz	380-415v,50Hz	220-240v, 50Hz	380-415v,50Hz
PHASE		Single	Single	Single	Single	Three	Single	Three	Single	Three
SYSTEM POWER INPUT (kW)	Heating/Cooling (nominal)	1.361 / 1.25	1.745 / 1.521	2.156 / 1.829	3.018 / 2.317	3.018 / 2.317	3.954 / 3.846	3.954 / 3.846	4.432 / 3.941	4.432 / 3.941
	Heating/Cooling (UK)	1.21 / 1.06	1.55 / 1.29	1.92 / 1.55	2.41 / 1.99	2.41 / 1.99	3.51 / 3.26	3.51 / 3.26	3.94 / 3.35	3.94 / 3.35
STARTING CURRENT (A)		5.0	6.0	6.0	13.0	6.0	13.0	6.0	13.0	6.0
SYSTEM RUNNING CURRENT (A)	Heating/Cooling [MAX]	5.95 / 5.37 [13.4]	7.43 / 6.48 [19.4]	9.23 / 7.81 [19.4]	12.97 / 9.97 [27.2]	4.34 / 3.31 [8.7]	16.87 / 16.46 [27.3]	5.69 / 5.54 [10.3]	18.76 / 16.66 [28.9]	6.42 / 5.71 [13.9]
FUSE RATING (BS88) - HRC (A)		16	25	25	32	16	32	16	40	16
MAINS CABLE NO. CORES		3	3	3	3	5	3	5	3	5
MAX PIPE LENGTH (m)		50	55	55	100	100	100	100	100	100
MAX HEIGHT DIFFERENCE (m)		30	30	30	30	30	30	30	30	30
CHARGE REFRIGERANT (kg) / CO ₂ EQUIVALENT (t)	R32 (GWP 675) - 30m	2.00 / 1.35	2.80 / 1.89	2.80 / 1.89	4.00 / 2.70	4.00 / 2.70	4.00 / 2.70	4.00 / 2.70	4.00 / 2.70	4.00 / 2.70
MAX ADDITIONAL REFRIGERANT (kg) / R32 (GWP 675) CO ₂ EQUIVALENT (t)		0.30 / 0.20	0.80 / 0.54	0.80 / 0.54	2.80 / 1.89	2.80 / 1.89	2.80 / 1.89	2.80 / 1.89	2.80 / 1.89	2.80 / 1.89

³ Three Phase

Product Dimensions

Front View

Upper View

Side View

Front View

Upper View

Side View

Front View

Upper View

Side View

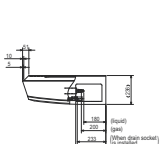
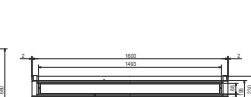
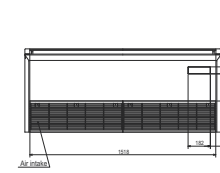
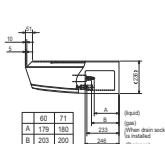
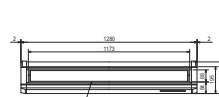
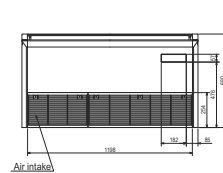
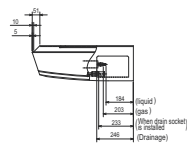
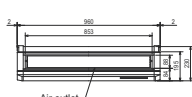
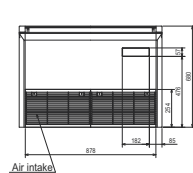

PUZ-ZM R32 Power Inverter Heat Pump

Outdoor Unit

Product Specifications



Product Dimensions PUZ-ZM35/50VKA

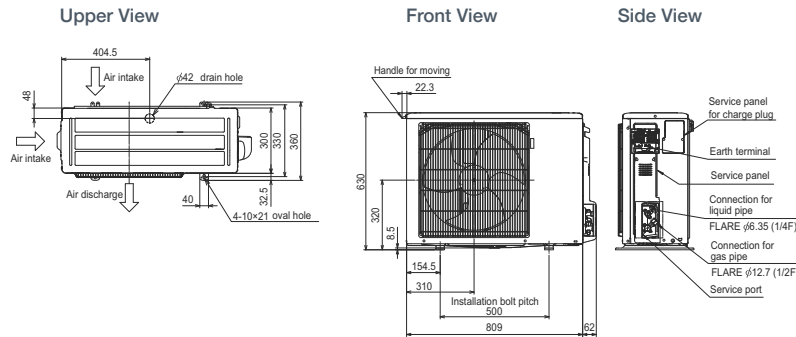

Product Dimensions PUZ-ZM60/71VHA

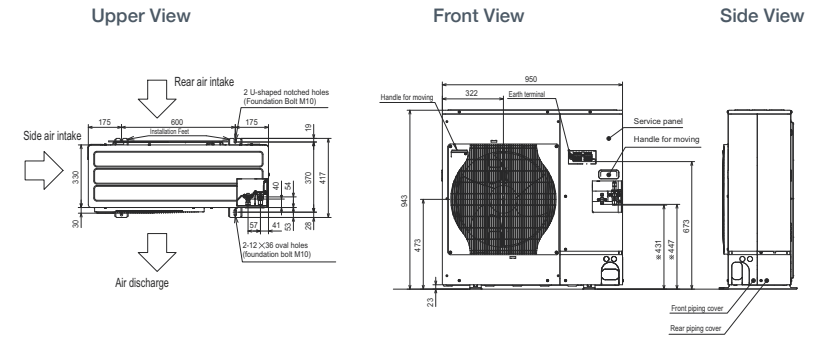

Product Dimensions PUZ-ZM100/125/140VKA, PUZ-ZM100/125/140YKA

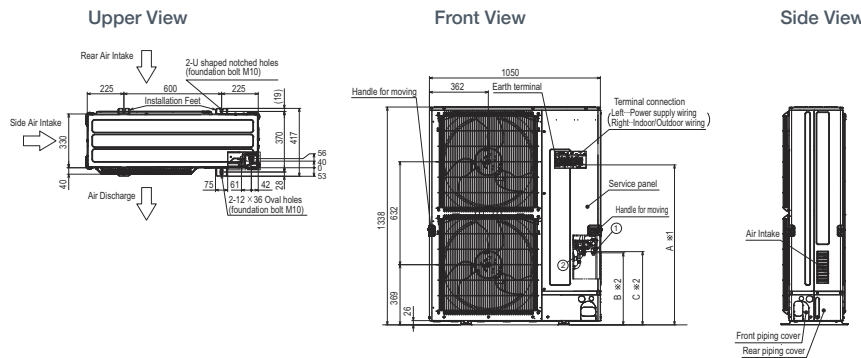

① Refrigerant GAS pipe connection ø15.88 (5/8F)	② Refrigerant LIQUID pipe connection ø9.52 (3/8F)
--	--

MODEL	A	B	C
PUZ-ZM100-140VKA	1067	442	450
PUZ-ZM100-140YKA	919	442	450

*1 - Indication of Terminal connection location.
*2 - Indication of STOP VALVE connection location.



Telephone: 01707 282880

email: air.conditioning@meuk.mee.com web: airconditioning.mitsubishielectric.co.uk microsite: timeforR32.co.uk

UNITED KINGDOM Mitsubishi Electric Europe Living Environment Systems Division, Travellers Lane, Hatfield, Hertfordshire, AL10 8XB, England. General Enquiries Telephone: 01707 282880 Fax: 01707 278881
IRELAND Mitsubishi Electric Europe, Westgate Business Park, Ballymount, Dublin 24, Ireland. Telephone: Dublin (01) 419 8800 Fax: Dublin (01) 419 8890 International code: (003531)

Country of origin: United Kingdom - Japan - Thailand - Malaysia. ©Mitsubishi Electric Europe 2017. Mitsubishi and Mitsubishi Electric are trademarks of Mitsubishi Electric Europe B.V. The company reserves the right to make any variation in technical specification to the equipment described, or to withdraw or replace products without prior notification or public announcement. Mitsubishi Electric is constantly developing and improving its products. All descriptions, illustrations, drawings and specifications in this publication present only general particulars and shall not form part of any contract. All goods are supplied subject to the Company's General Conditions of Sale, a copy of which is available on request. Third-party product and brand names may be trademarks or registered trademarks of their respective owners.

Note: The fuse rating is for guidance only. Please refer to the relevant databook for detailed specification. It is the responsibility of a qualified electrician/electrical engineer to select the correct cable size and fuse rating based on current regulation and site specific conditions. Mitsubishi Electric's air conditioning equipment and heat pump systems contain a fluorinated greenhouse gas, R410A (GWP:2088), R32 (GWP:675), R407C (GWP:1774) or R134a (GWP:1430). *These GWP values are based on Regulation (EU) No 517/2014 from IPCC 4th edition. In case of Regulation (EU) No.626/2011 from IPCC 3rd edition, these are as follows. R410A (GWP:1975), R32 (GWP: 550), R407C (GWP:1650) or R134a (GWP:1300).



Effective as of October 2017 SAP No. 317318



www.greengateway.mitsubishielectric.co.uk

Mitsubishi Electric UK's commitment to the environment

Follow us @meuk_les
Follow us @green_gateway

Mitsubishi Electric
Living Environmental Systems UK

mitsubishielectric2

thehub.mitsubishielectric.co.uk



timeforR32.co.uk