



**Air-conditioner Control System Optional Parts
Mounting attachment B type for use with AG-150A
PAC-YG81TB
Installation Manual**

Applicable Model	Centralized Controller AG-150A
------------------	--

1 Safety Precautions

- Before installing the Mounting attachment B type, please read the following safety precautions carefully to ensure proper installation.
- Observe the following precautions to ensure safety.
- The following symbols are used in this manual to indicate the type and severity of potential consequences that may result when given instructions are not followed exactly as stated.

WARNING	Indicates a risk of death or serious injury.
CAUTION	Indicates a risk of injury or damage to the product.

- After the completion of installation, perform a test run to confirm proper operation.
- Retain this manual for future reference. When the unit is reinstalled or repaired, make this manual available to those who provide these services. Make sure that the manual is passed on to any future air condition system users.



WARNING	
<p>Only a dealer or qualified technician should replace the unit. Improper replacement by an unqualified person may result in electric shock or fire.</p>	<p>Install the Mounting attachment B type properly according to the instructions detailed in this Installation Manual. Improper installation by an unqualified person may result in electric shock or fire.</p>
<p>The Mounting attachment B type should be installed on a surface that is strong enough to support the weight of the unit. If the Mounting attachment B type is installed on a surface that lacks the strength to support it, it may fall and cause injury.</p>	<p>Electric work must be performed by authorized personnel according to the local regulations and the instructions detailed in the Installation Manual. Inadequate circuit capacity or improper installation may result in electric shock or fire.</p>
<p>Do not attempt to modify or repair the Mounting attachment B type. Modification or improper repair may result in electric shock or fire. Consult your dealer when repairs are necessary.</p>	<p>Ask your dealer or an authorized technician to move the Mounting attachment B type. Improper installation by an unqualified person may result in electric shock or fire. Consult your dealer or a qualified technician.</p>

CAUTION	
<p>Do not install the Mounting attachment B type where there is a risk of leaking flammable gas. If the leaked gas accumulates around the Electric Box, it may ignite and cause an explosion.</p>	<p>Do not install this Mounting attachment B type in a place that has the potential for steam, such as a bathroom or kitchen. Steam may cause an electric shock or a unit malfunction.</p>
<p>Do not use the Mounting attachment B type in an environment that has high concentrations of oil, steam, or sulfuric gas. These substances may have adverse effects on the performance of the Mounting attachment B type or damage its parts.</p>	<p>Do not install this Mounting attachment B type where an acid, alkaline solution, or special chemical spray is used frequently to avoid electric shock or malfunction.</p>
<p>Seal the wire access holes with putty to prevent dew, water, and insects from entering to avoid electric shock.</p>	<p>Keep the cables from coming in direct contact with the edges of the wire access holes. If the cables are damaged, they may cause electric shock or fire.</p>
	<p>This Mounting attachment B type is for exclusive use with the AG-150A and cannot be used with other devices.</p>

2 Parts List

The Installation Manual and the parts listed below are included with the package.

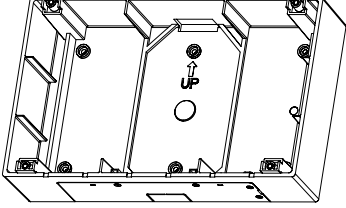
* Leave the Mounting attachment B type in the package until ready to install to protect it from damage.

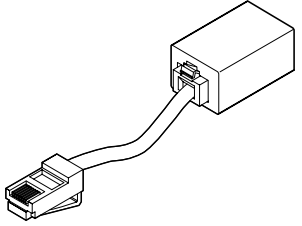
Name	① Mounting attachment B type (PAC-YG81TB)	② AG-150A mounting screws	③ LAN link-up cable
Quantity	1	4	1
Shape		Roundhead screws M4×16 	

3 Field-supplied parts

The following parts are necessary to mount the Mounting attachment B type (PAC-YG81TB) on the wall.

Name	① Wall mounting screws (M4)
Quantity	6

Use screws that are suitable for the wall type.

The weight of the AG-150A including the Mounting attachment B type (PAC-YG81TB) is 2.7 kg (6.0 lbs).

Use screws with the head size of between 7.0 and 8.8 mm (5/16 and 6/16 in).

4 External Dimensions

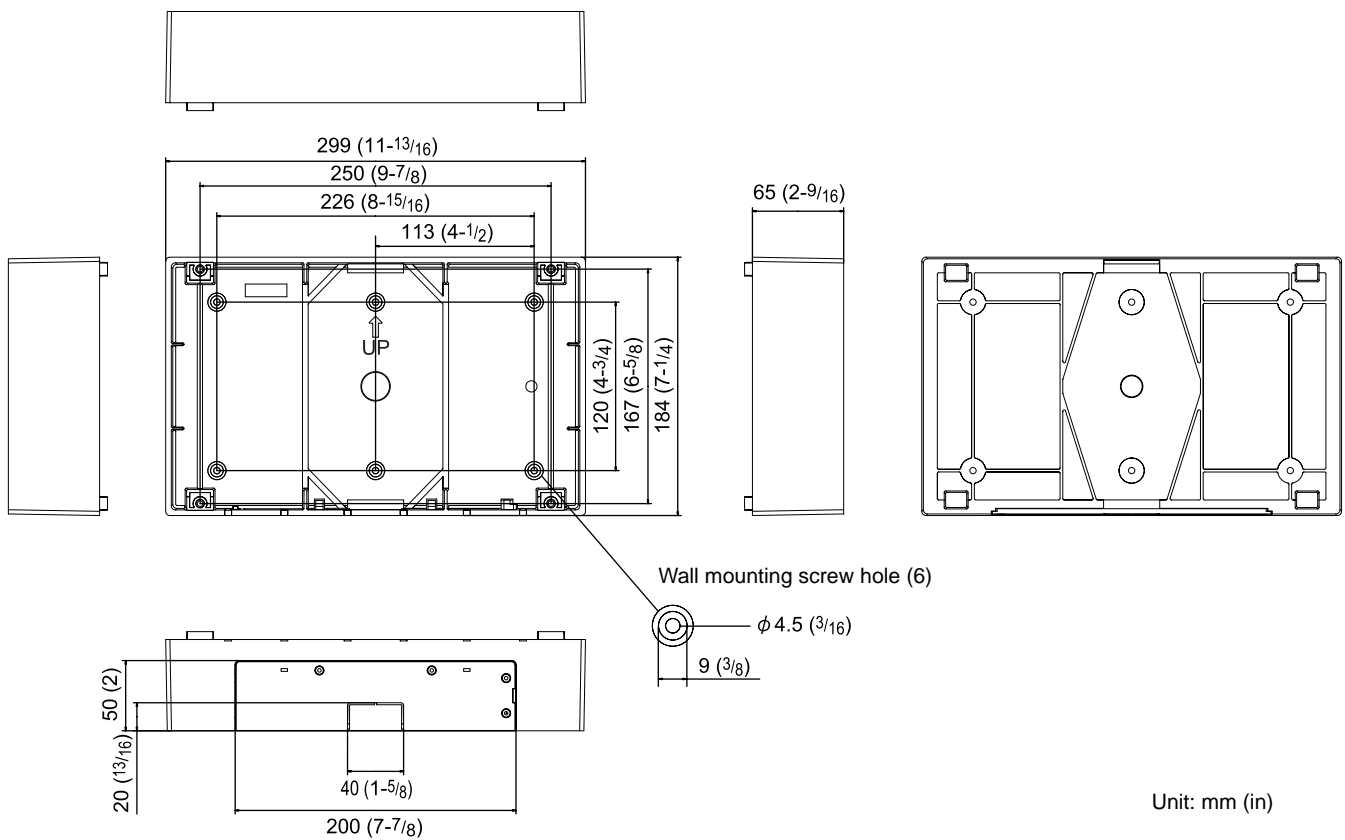

5 Selecting an Installation Site

1. Required installation space

Install the Mounting attachment B type (PAC-YG81TB) where the space indicated in the figure below can be secured.

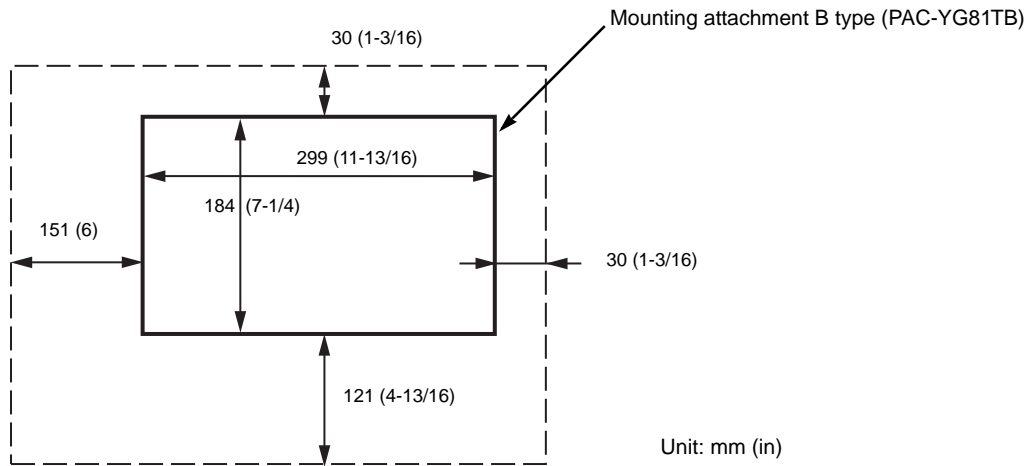

6 Installation

The cable can be routed either from the top or the bottom.

1. To route the cable from the top

- (1) Cut out the knockout hole on the Mounting attachment B type (PAC-YG81TB) at the top with a nipper for the cable (the thin part of the plastic).

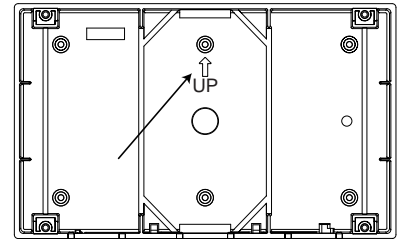
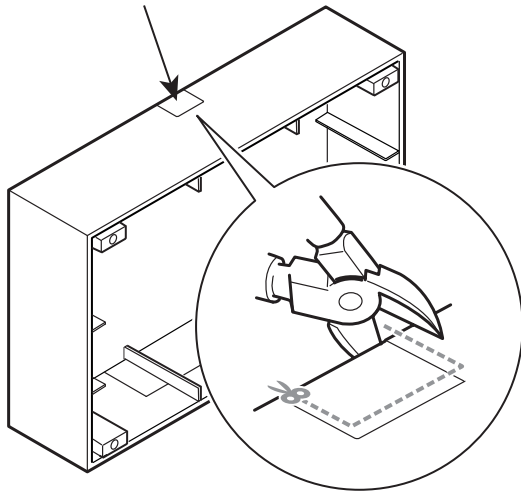

NOTE

Install the Mounting attachment B type (PAC-YG81TB) so that the arrow (↑UP) on the back of it points up.

- (2) Sand the cut surface of the knockout hole smooth.

CAUTION

Any rough edges that are left may damage the cable and cause electric shock or fire.

- (3) Install the Mounting attachment B type (PAC-YG81TB) with the six mounting screws (field-supplied). Use screws that are suitable for the wall type. Install it on the surface strong enough to support its weight.

NOTE

Install the Mounting attachment B type (PAC-YG81TB) so that the arrow (↑UP) on the back of it points up.

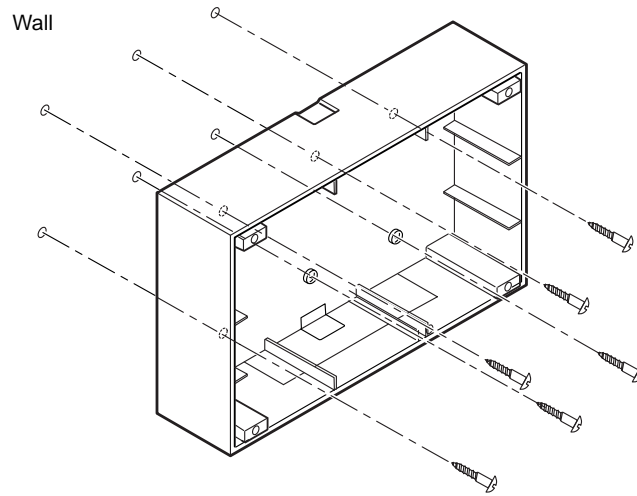

- (4) Push the cable through the knockout hole.

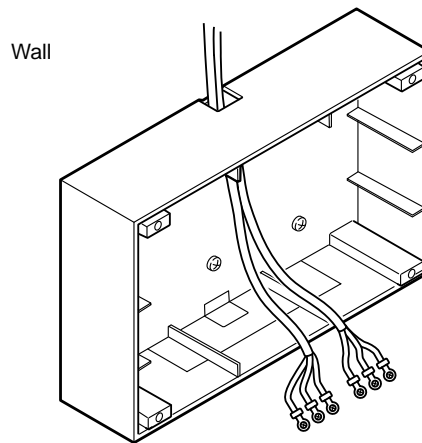

- (5) Remove AG-150A surface cover.

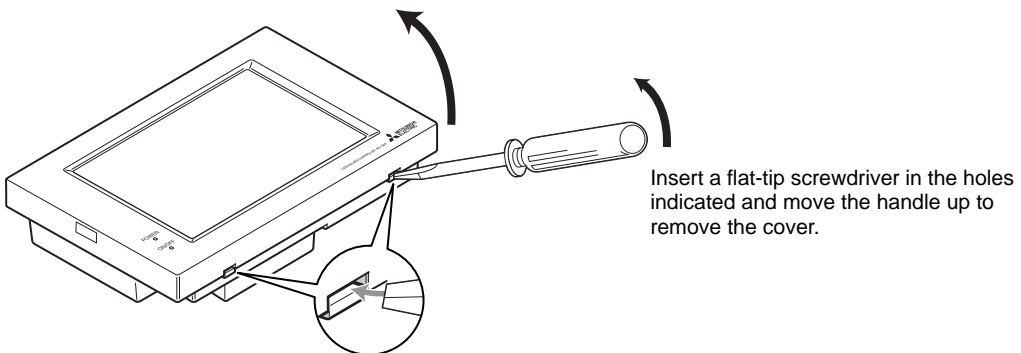

- (6) Connect the cable to the AG-150A.
Refer to the AG-150A Installation Manual for details.

CAUTION

* When routing the cable from the top of the controller, let the cable hang down below the connector before connecting it to the terminal block or connector as shown in the figure below to prevent water from running down the cable and cause electric shock or fire.

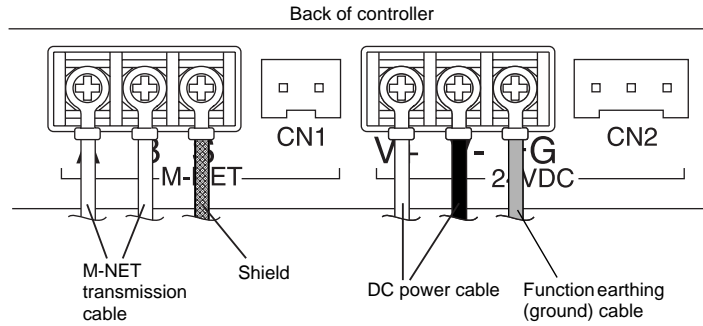

- (7) If the AG-150A is not always connected to the LAN, connect the supplied LAN link-up cable to the LAN connector.
(* If the AG-150A is always connected to the LAN, connect the LAN cable (field supplied) via a HUB and the LAN link-up cable is not required.)

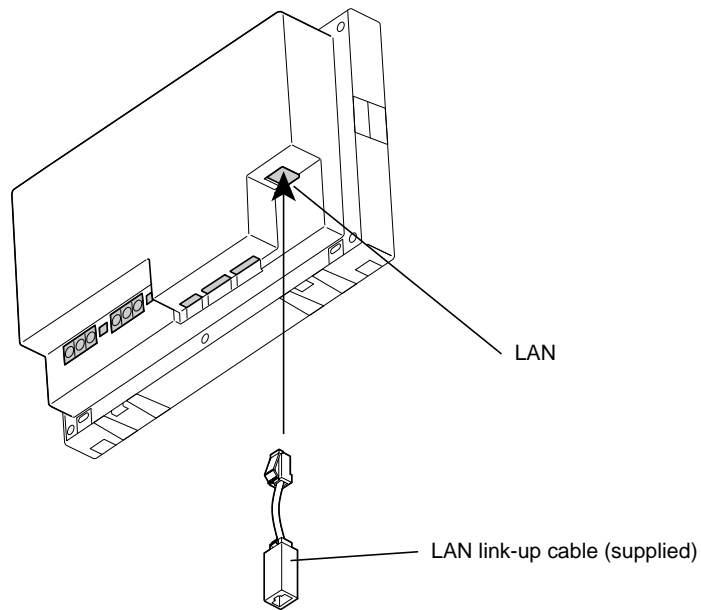

- (8) Securely seal the cable lead-in port with putty to prevent dew, water and insect, etc. from entering.

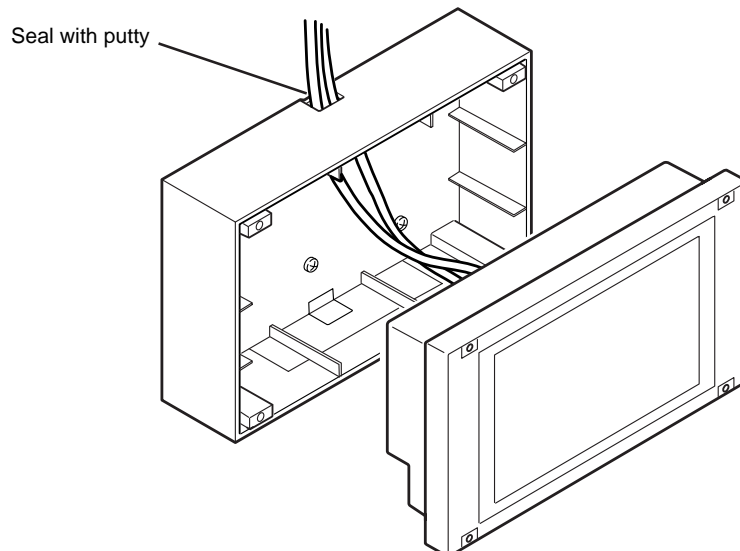

- (9) Install the AG-150A with the four screws that are supplied.
If the LAN link-up cable is used, place it inside the Mounting attachment B type.

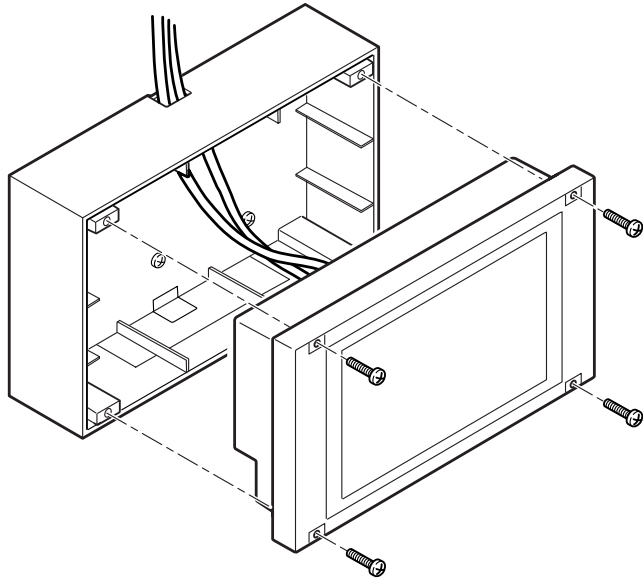

- (10) Attach the cover on the AG-150A.

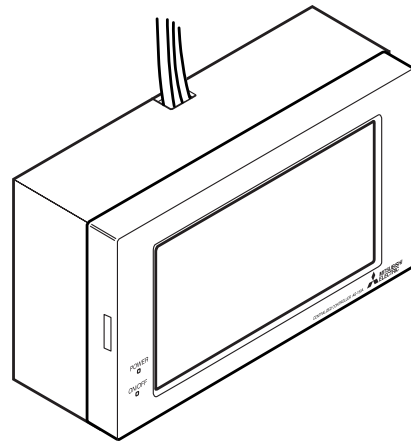

2. To route the cable from the bottom

- (1) Cut out the knockout hole on the Mounting attachment B type (PAC-YG81TB) at the bottom with a nipper for the cable.

NOTE

Install the Mounting attachment B type (PAC-YG81TB) so that the arrow (↑UP) on the back of it points up.

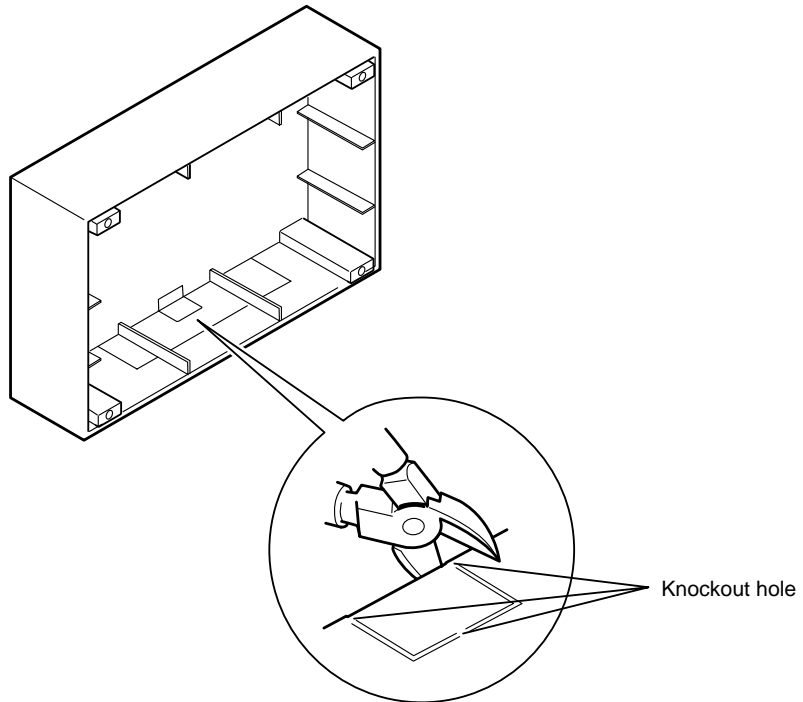

- (2) Sand the cut surface of the knockout hole smooth.

CAUTION

Any rough edges that are left may damage the cable and cause electric shock or fire.

- (3) Install the Mounting attachment B type (PAC-YG81TB) with the six mounting screws (field-supplied). Use screws that are suitable for the wall type. Install it on the surface strong enough to support its weight.

NOTE

Install the Mounting attachment B type (PAC-YG81TB) so that the arrow (↑UP) on the back of it points up.

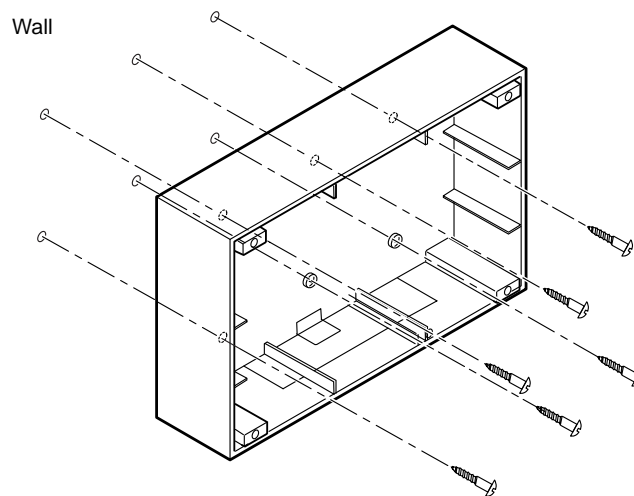

(4) Push the cable through the knockout hole.

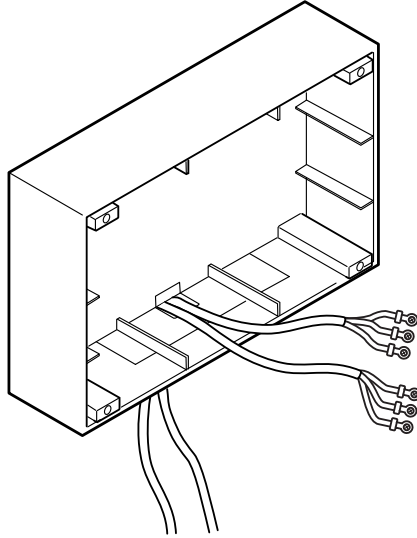

(5) Remove AG-150A surface cover.

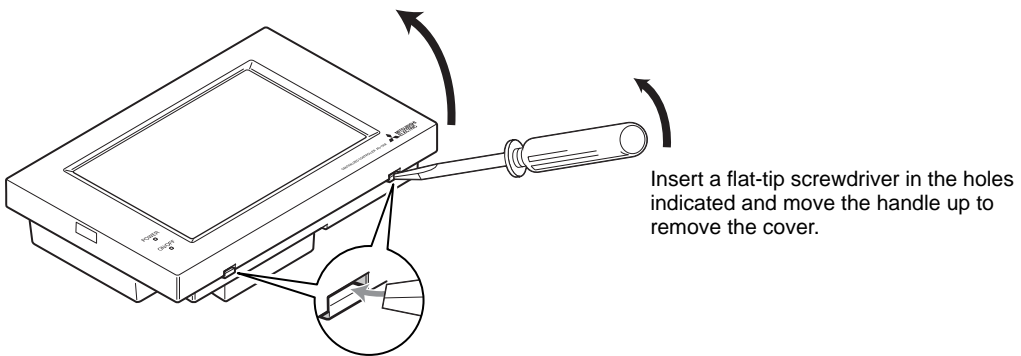

(6) Connect the cable to the AG-150A.
Refer to the AG-150A Installation Manual for details.

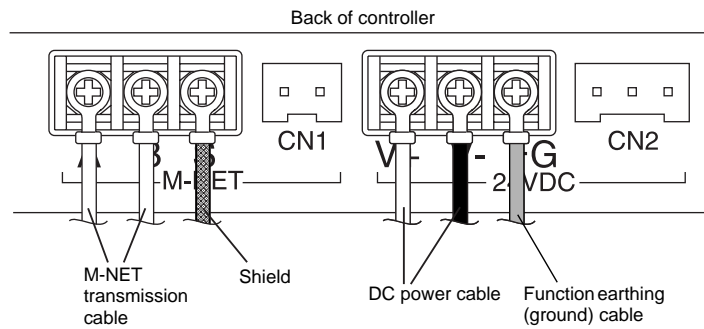

- (7) If the AG-150A is not always connected to the LAN, connect the supplied LAN link-up cable to the LAN connector.
(* If the AG-150A is always connected to the LAN, connect the LAN cable (field supplied) via a HUB and the LAN link-up cable is not required.)

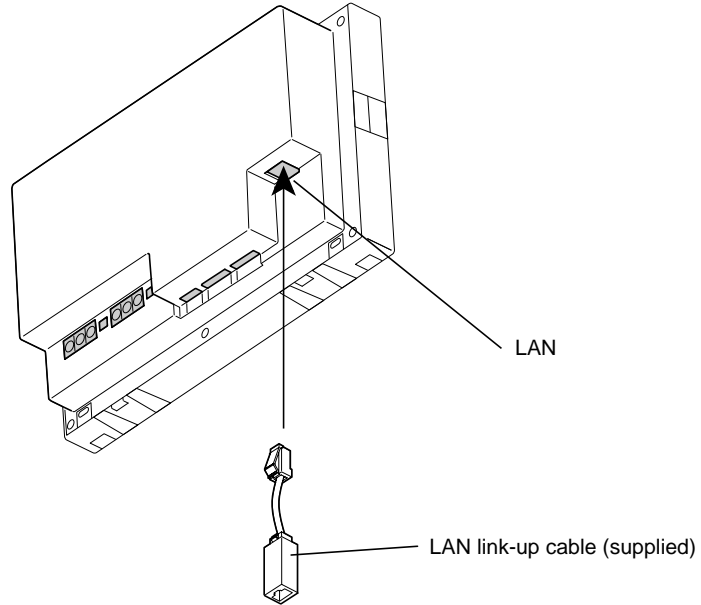

- (8) Install the AG-150A with the four screws that are supplied.
If the LAN link-up cable is used, place it inside the Mounting attachment B type.

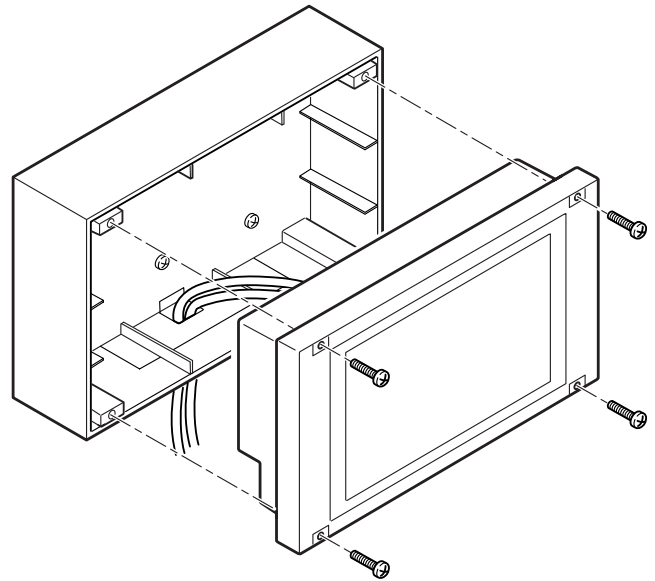

- (9) Attach the cover on the AG-150A.

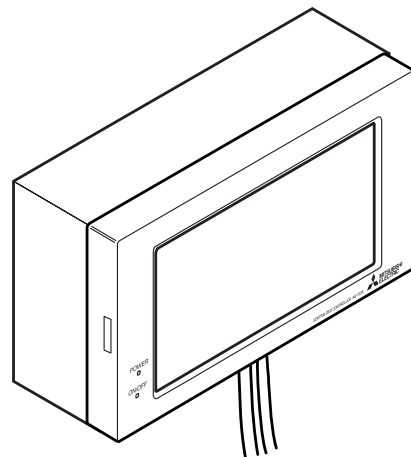

7 Access panel

There is a maintenance access panel at the bottom of the Mounting attachment B type.

The maintenance access panel is used for maintenance purpose when the AG-150A is not always connected to the LAN.

To open the maintenance access panel

(1) Unscrew the four screws on the panel with a Phillips driver.

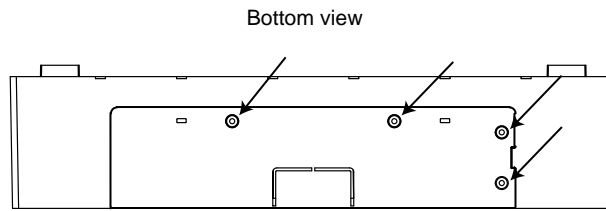

(2) Remove the panel by placing your finger on the dent at right and pulling it down.

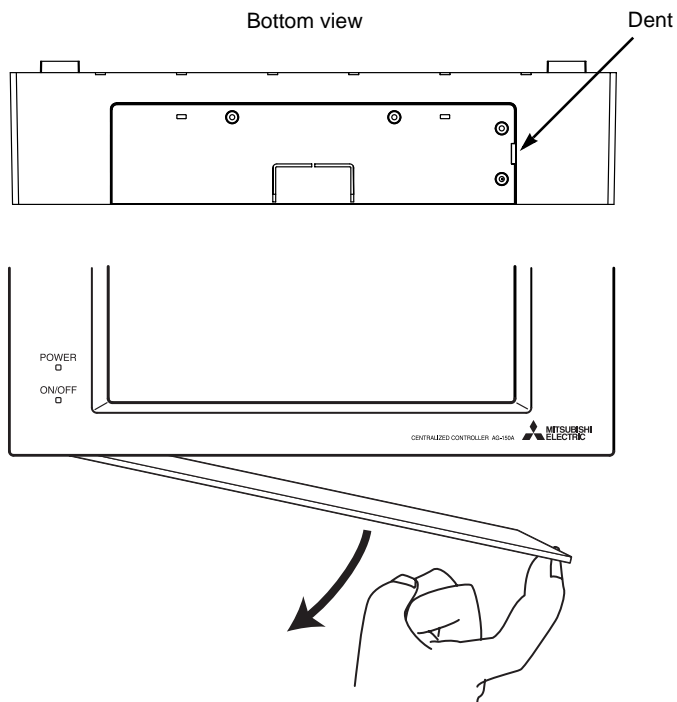

If the AG-150A is not always connected to the LAN, connect a LAN cable to the LAN link-up cable through this maintenance access panel to upgrade the AG-150A software as necessary.

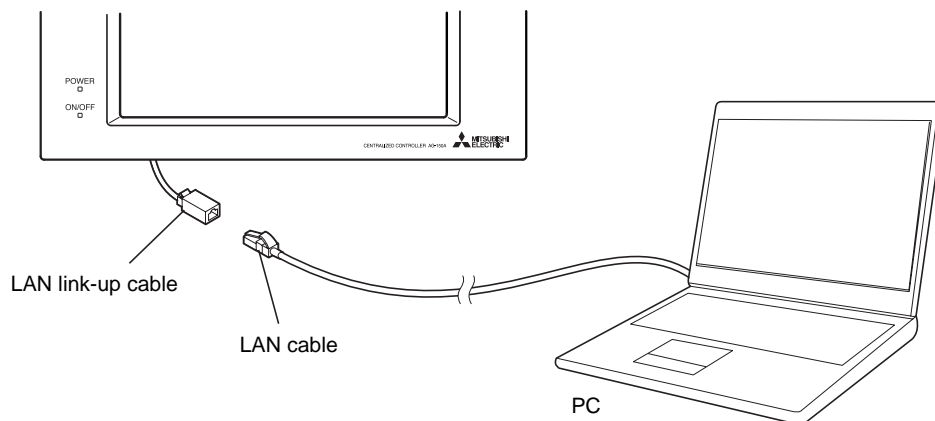

Please be sure to put the contact address/telephone number on
this manual before handing it to the customer.

 **mitsubishi electric corporation**

HEAD OFFICE: TOKYO BLDG. , 2-7-3, MARUNOUCHI, CHIYODA-KU, TOKYO 100-8310, JAPAN

Authorized representative in EU: MITSUBISHI ELECTRIC EUROPE B.V.

HARMAN HOUSE, 1 GEORGE STREET, UXBRIDGE, MIDDLESEX UB8 1QQ, U.K.

WT05422X02
Printed in Japan
Recycled Paper