Procon

MELCOTEL

FOR INSTALLERS

INSTALLATION MANUAL

Version 3.01

For safe and correct use, please read this installation manual thoroughly before installing the PROCON MELCOTEL.

mitsubishi
MITSUBISHI ELECTRIC



Preface

Safety warnings

⚠ Caution:

Do not expose to rain or moisture.

⚠ Shielded Signal Cables:

Use only shielded cables for connecting peripherals to any Procon MELCOTEL device to reduce the possibility of interference with radio communications services. Using shielded cables ensures that you maintain the appropriate EMC classification for the intended environment.

⚠ CE Notice:

This product has been determined to be in compliance with 2004/108/EC (EMC Directive) and amendments of the European Union.

⚠ European Union, Class A:

Class A products are intended for use in non-residential/non-domestic environments. Class A products may also be utilized in residential/domestic environments but may cause interference and require the user to take adequate corrective measures.

This is a Class A product. In a domestic environment this product may cause radio frequency interference in which case the user may be required to take adequate measures.

A "Declaration of Conformity" in accordance with the preceding directives and standards has been made and is available on request.

If this equipment does cause interference with radio communications services, which can be determined by turning the equipment off and on, you are encouraged to try to correct the interference by one or more of the following measures:

- Reorient the receiving antenna.
- Relocate the Procon MELCOTEL with respect to the receiver.
- Move the Procon MELCOTEL away from the receiver.

If necessary, consult a Procon MELCOTEL technical support representative or an experienced radio/television or EMC technician for additional suggestions.

Disclaimer

⚠ Warranty:

All products manufactured on behalf of Mitsubishi Electric UK are warranted against defective materials for a period of three years from the date of delivery to the original purchaser.

⚠ Warning:

Mitsubishi Electric UK assumes no liability for damages consequent to the user of this product. We reserve the right to change this manual at any time without notice. The information furnished by us is believed to be accurate and reliable. However, no responsibility is assumed by us for its use, nor for any infringements of patents or other rights of third parties resulting from its use.

Amendment Register

Version	Date	Author	Notes
V1.00	22/05/09	SD/GD	Initial Version
V3.01	15/09/11	HI	Updated

Contents

Preface	3
<i>Safety warnings</i>	3
1. Quick set up	15
2. Overview	16
2.1 Overview with Key card system	17
2.2 Overview without Key card system.....	18
3. Physical Connections	19
3.1 Power Supply	19
3.2 Ethernet Connection.....	19
3.3 Outside Temperature Sensor.....	19
3.4 Fire Alarm Input.....	19
3.5 Key Switch / Window Contact / Refrigerant Detection System Connections.....	20
4. Power Up	21
4.1 Normal Power Up.....	21
4.2 Restoring Factory Settings	21
4.3 USB / RS485 / RS232 Port Selection.....	22
5. Clock Settings	23
5.1 Clock Synchronisation.....	23
6. Configuration	24
6.1 MELCOTEL Configuration Manager.....	24
6.2 Installing MELCOTEL Configuration Manager	24
6.3 Connecting to MELCOTEL.....	24
6.4 Global Settings.....	24
6.4.1 IP Addresses	24
6.4.2 G50 Enabled Flags.....	25
6.4.3 Enable Key Card Switches	25
6.4.4 Enable Window Contacts.....	25
6.4.5 Global Heating Deadband	25
6.4.6 Global Cooling Deadband.....	25
6.4.7 Force Off Times.....	25
6.4.8 Season Start Dates.....	26
6.4.9 Night-time Offset.....	26
6.4.10 Season Global Setpoint Offsets.....	27
6.4.11 Outside Temperature Offset	27
6.5 Group Settings	27
6.5.1 Group Enabled Flag.....	27
6.5.2 On Setting (Mode)	27
6.5.3 On Setting (Setpoint)	28
6.5.4 Setback Settings.....	28
7. Key Switch Control	30
7.1 NORMAL State	30
7.2 KEY CARD REMOVED State	30
7.3 WINDOW OPEN State	31
7.4 LOW SETBACK State.....	31
7.5 HIGH SETBACK State	31
8. Non Key Switch Control	33
8.1 NORMAL State	33
8.2 WINDOW OPEN State.....	33
8.3 LOW SETBACK State.....	34
8.4 HIGH SETBACK State	34
9. Fire Alarm Input	35

10. MELCOTEL and M2M (Remote Monitoring)	36
10.1 Introduction.....	36
10.2 MELCOTEL and M2M	36
10.3 MELCOTEL and M2M using window contact	37
10.4 MELCOTEL and M2M using refrigerant detection system.....	37
11. Applicable Air Conditioning Models	38
11.1 Using key card and / or window sensor	38
11.2 NOT Using key card and / or window sensor	38
12. Important Notes	39
13. Troubleshooting	40
14. Appendix	41
14.1 Appendix 1 – User settings 1	41
14.2 Appendix 2 – User settings 2.....	42
14.3 Appendix 3 – User settings 3.....	44
14.4 Appendix 4 – User settings 4.....	45

1

[Fig. 1]

Items included with the MELCOTEL

A 1 x MELCOTEL

B 1 x OUTDOOR SENSOR

A

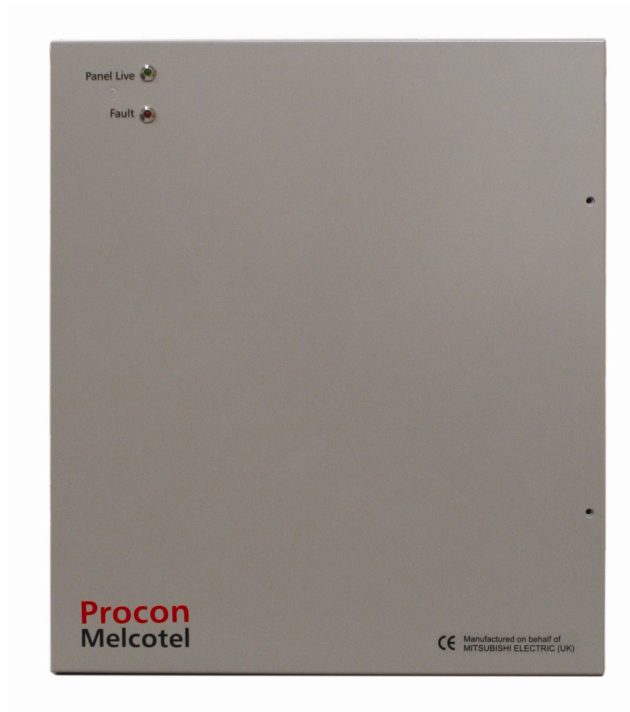

B



2

[Fig. 2]

Inside and the outside of the MELCOTEL

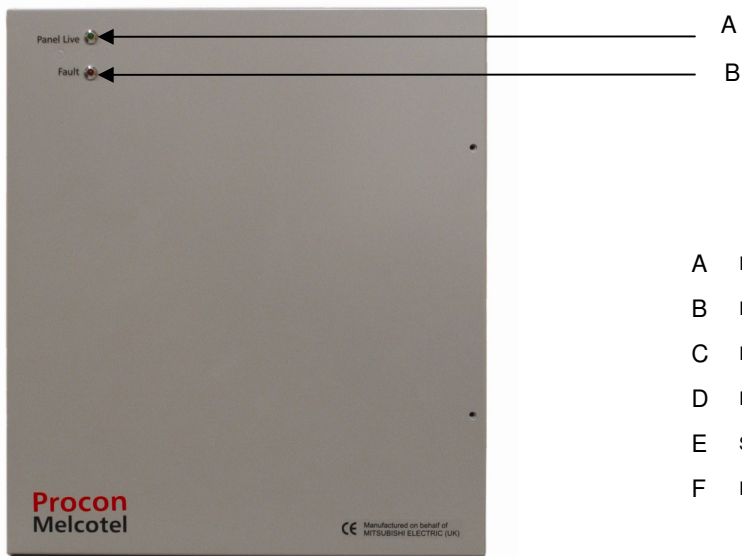

- A Power LED
- B Fault LED
- C Reset and SYNC button
- D Power supply terminal
- E Sensor and fire alarm inputs
- F Ethernet connection

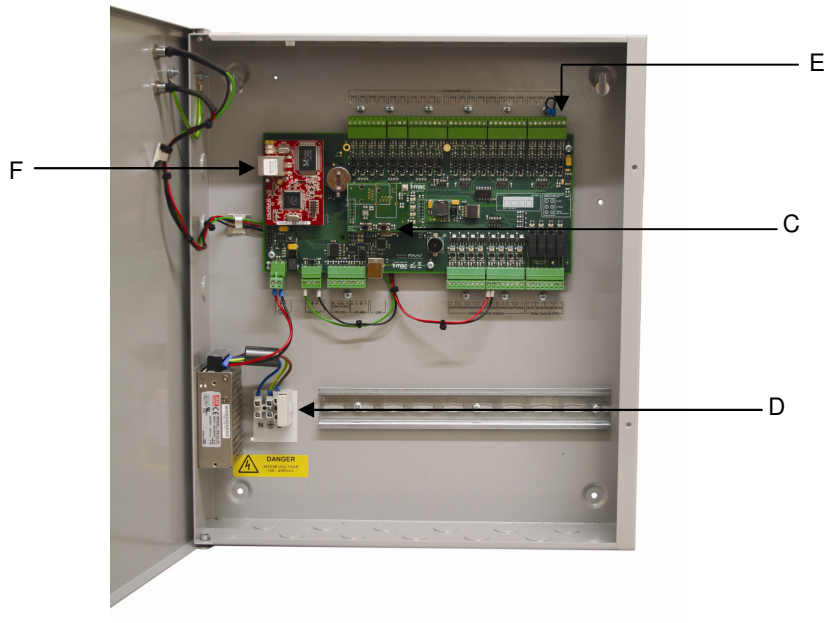

3

[Fig. 3]

Wiring diagram of the MELCOTEL

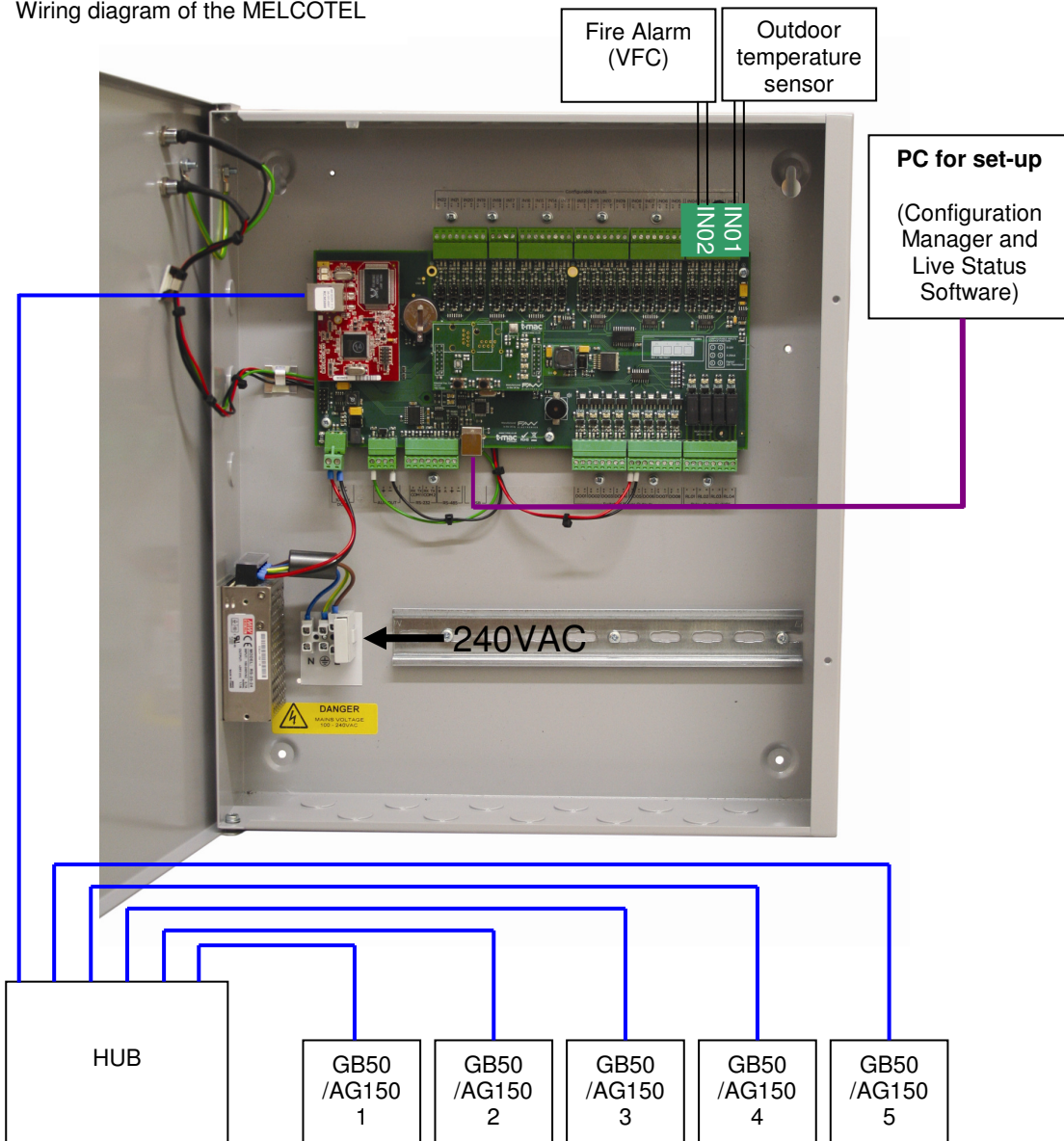

Notes:

- HUB and network cables (—) not supplied by MEUK
- MELCOTEL and HUB will require 240VAC power supply
- Network cables must be patch network cable and NOT cross over
- Network cables must be a maximum of 100m long

4

[Fig. 4]

Wiring diagram of each indoor unit using a key card volt free contact

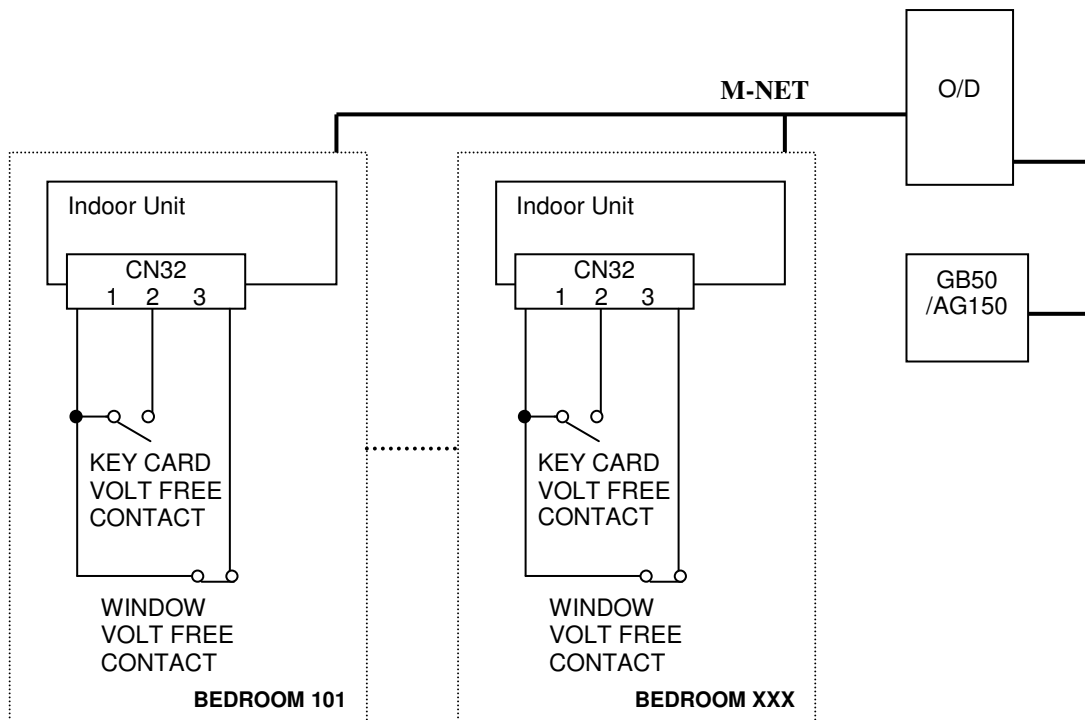

Notes:

- A PAC-SA89TA (3 wire adaptor) is required for each indoor unit
- Keycard contact is normally opened
- Window contact is normally closed

5

[Fig. 5]

Wiring diagram of each indoor unit when not using a key card volt free contact

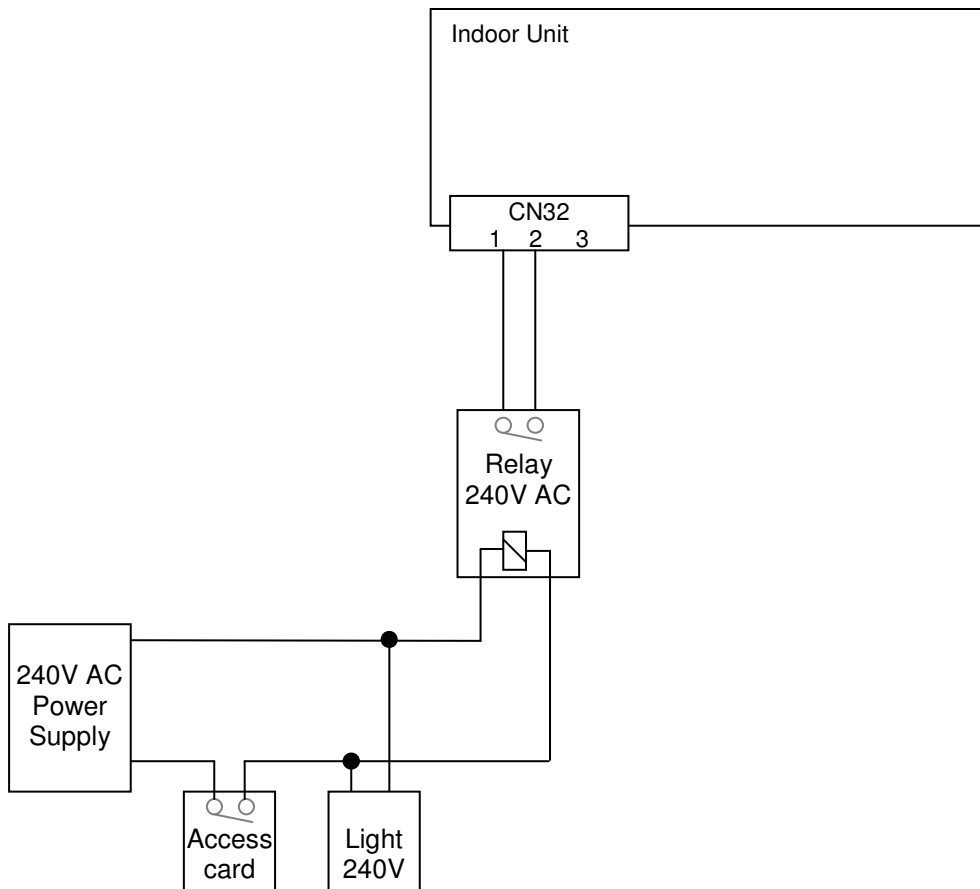

Notes:

- When the keycard contact does not have a volt free contact and supplies the bedroom lighting it is necessary to install an additional relay as shown above

6

[Fig. 6]

State diagram for the key switch control

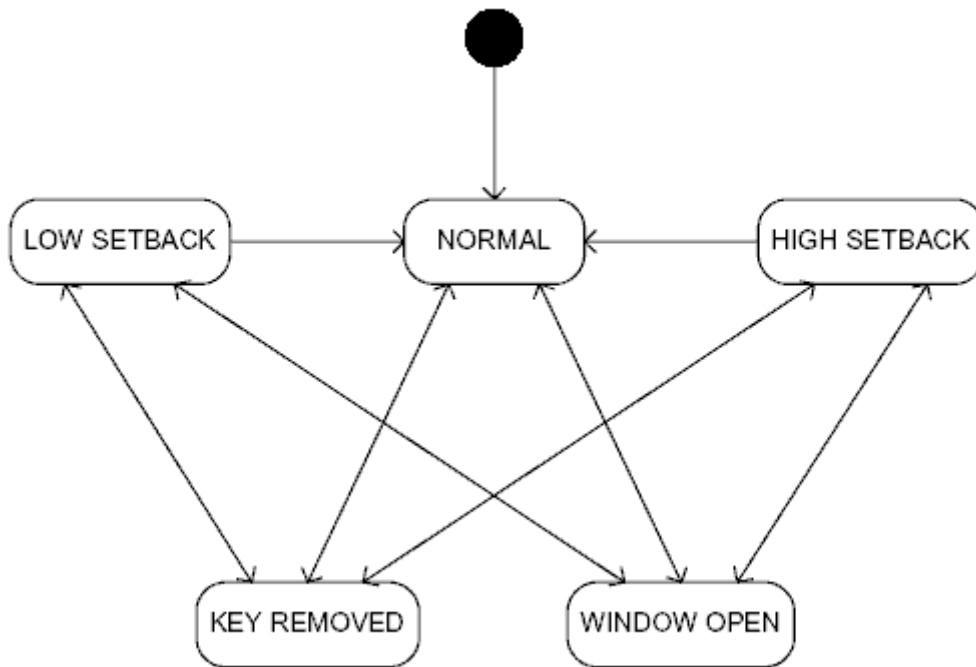

7

[Fig. 7]

State diagram for the non key switch control

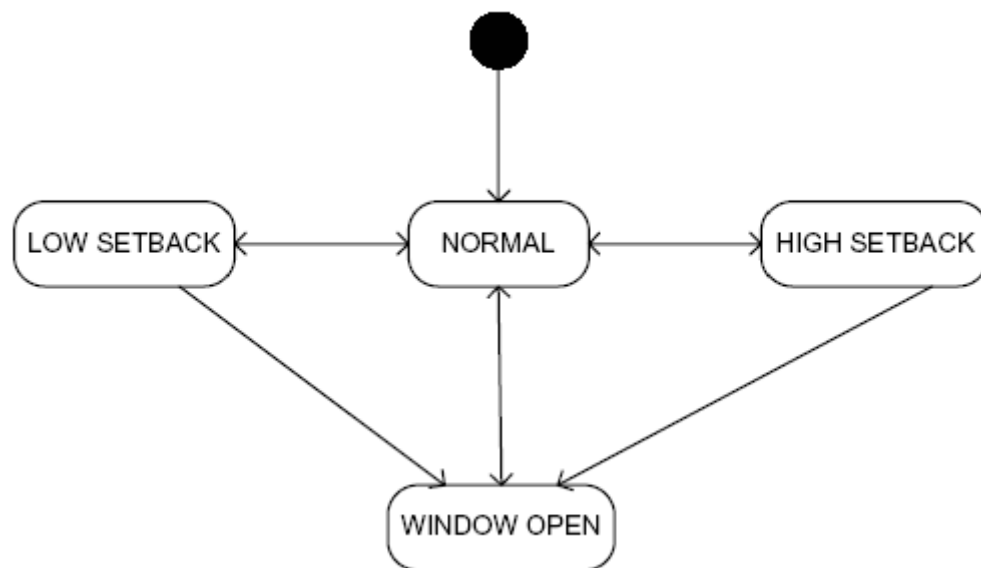

8

[Fig. 8]

Wiring diagram between the MELCOTEL and the Mini M2M

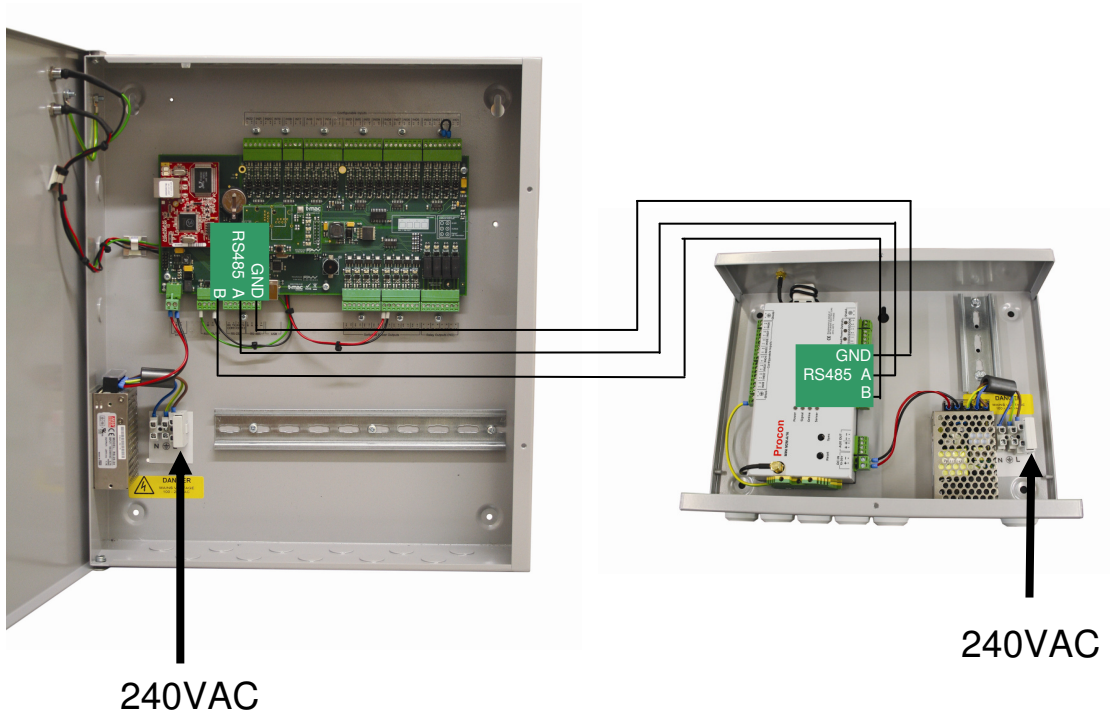

Notes:

- GND should be connected
- Shielded cable must be used
- For communication over RS-485 all 3 connections are needed. These are labelled A, B and GND
- The RS-485 cable must be a shielded data cable. Mains flex or other unshielded cable must not be used
- The cable shield must be connected to GND at one end only
- RS-485 has polarised data connections. It is crucial that 'A' is connected together, 'B' is connected together and 'GND' is connected together

1. Quick set up

Step 1:

Ensure that the following DIP switches are set for each indoor unit:

- SW1-1 ON (to activate remote controller sensor)
- SW1-9 ON (to activate input on indoor unit)
- SW1-10 ON (to activate input on indoor unit)

Step 2:

Connect the MELCOTEL to the GB50(s) or AG150(s) using Ethernet patch network cable and a hub.

Step 3:

Connect if required the outdoor temperature sensor using IN01.

Step 4:

Connect if required the fire alarm using IN02. The contact must be normally closed.

Step 5:

Connect CN32 for each indoor unit using a PAC-SA89TA if using key card and/or window contacts:

- Key card volt free contact normally opened PIN 1 and 2
- Window volt free contact normally closed PIN 1 and 3

Step 6:

Activate PIN Code on each GB50/AG150

- GB50 License package for GB50
- AG150-Basic for AG150

Step 7:

Install the MELCOTEL Configuration Manager software on your PC.

Step 8:

Hold the MELCOTEL SYNC button and switch it ON. Release the MELCOTEL SYNC button 3 seconds after the power up beep is heard.

Step 9:

Connect the USB cable between your laptop and the MELCOTEL.

Step 10:

Configure the MELCOTEL and power cycle it when complete.

2. Overview

The Procon MELCOTEL is designed to be used in hotels as a central controller for City Multi indoor units, via G50/GB50/AG150 controllers. MELCOTEL can connect to up to five G50/GB50/AG150 controllers simultaneously via Ethernet, so up to 250 City Multi units can be indirectly controlled.

MELCOTEL can provide different types of control depending on the application. Some hotels may have a key card entry system where the room occupant inserts a key card when entering the room. This can be used to force the indoor unit on when the key card is present, and switch it off when not present. Some hotels may also have window contact switches installed which switch when the room window is opened. In some cases, refrigerant detection system may be also connected to the same terminal instead of the window contact. Those 2 options, window contact or refrigerant detection system can be used to switch the indoor unit off when the window is open or when the refrigerant detection system is activated. Both these switches can be connected to digital inputs on the indoor unit, MELCOTEL continually monitors them and detects any change in state.

MELCOTEL can optionally be connected to a fire alarm panel and used to force all indoor units off in the event of the fire alarm being activated.

There are two PC applications which complement MELCOTEL, *MELCOTEL Configuration Manager* and *MELCOTEL Live Status*. These applications require a USB connection to MELCOTEL (or optionally an RS232 connection). Both pieces of software cannot be used simultaneously. MELCOTEL Configuration Manager can be used for changing any configuration settings, and should be used only when commissioning the system or making future amendments. MELCOTEL Live Status can be used to monitor the current status of all indoor units in the hotel. This can be used at any time.

MELCOTEL has an RS-485 port which enables live status information to be read out using the Modbus RTU protocol. MELCOTEL acts as a Modbus slave device which will connect to any Modbus master device, such as a Procon Mini M2M-A/16 or Procon Maxi M2M-IP/50.

The only physical connections needed when installing MELCOTEL are:

- 110 – 240 VAC (50 – 60 Hz) power supply
- Ethernet connection to network containing the G50/GB50/AG150s
- External thermistor temperature sensor (optional)
- Normally closed connection to fire alarm panel (optional)
- Wire link to use RS232 instead of USB (optional)

Figure 1 shows the items included with the MELCOTEL.

Figure 2 shows the inside and the outside of the MELCOTEL.

Figure 3 shows the wiring diagram of the MELCOTEL.

Figure 4 shows the wiring diagram of each indoor unit using a key card volt free contact.

Figure 5 shows the wiring diagram of an each indoor unit when not using a key card volt free contact.

Figure 6 shows a state diagram for key switch control.

Figure 7 shows a state diagram for non key switch control.

Figure 8 shows the wiring diagram between the MELCOTEL and the Mini M2M.

2.1 Overview with Key card system

The key card system is used to detect if the room is occupied or not.

When the room is occupied (Key card in), the MELCOTEL switches ON the A/C to “occupied settings” for instance, ON, AUTO, 21 °C.

When the room is not occupied (Key card out), the MELCOTEL sets the room in “Night Set Back” and monitors the room temperature using the remote controller sensor. If the room temperature is too low and below the Low Low Setpoint, for instance 16 °C, the MELCOTEL will restart the A/C to “Low High Setpoint + Heating Deadband” for instance 18 °C+2 °C=20 °C. When the room temperature has reached “Low High Setpoint”, in this example 18 °C the MELCOTEL will switch OFF the A/C to save energy.

The same principle works in cooling. If the room temperature is too high and above High High Setpoint, for instance 27 °C, the MELCOTEL will restart the A/C to “High Low Setpoint - Cooling Deadband” for instance 25 °C-3 °C=22 °C. When the room temperature has reached “High Low Setpoint”, in this example 25 °C the MELCOTEL will switch OFF the A/C to save energy.

At any time, if a window sensor is installed and activated, the MELCOTEL will switch OFF the A/C when the window is opened and the occupied/unoccupied settings will be deactivated.

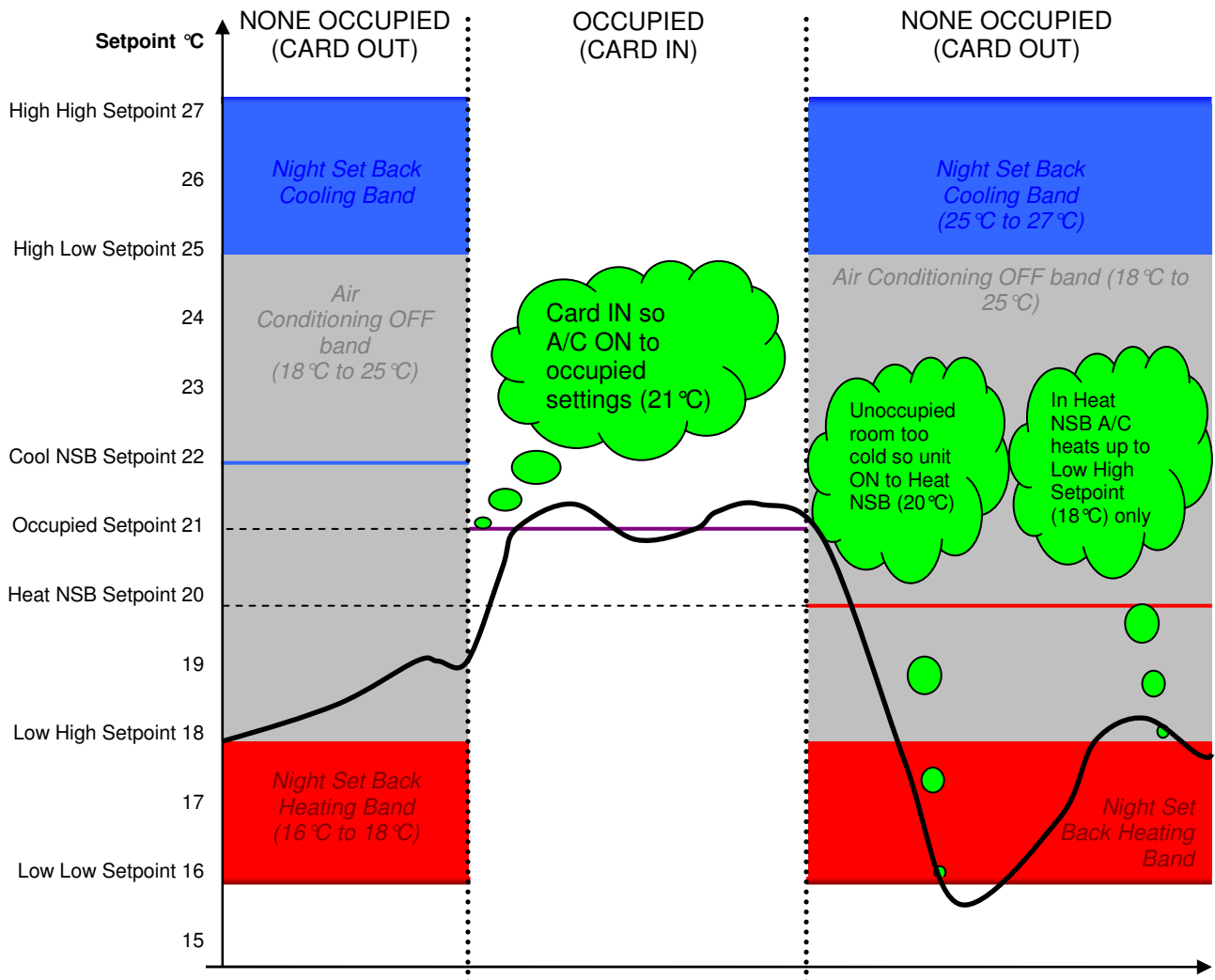

NSB: Night set back

2.2 Overview without Key card system

Each time the A/C is switched ON, the room is deemed as occupied.

When someone switches ON the A/C, the MELCOTEL will reset the settings to “occupied settings” for instance, ON, AUTO, 21 °C.

After some time, the MELCOTEL will switch OFF the A/C to save energy. This time is predefined with the OFF time settings. Six OFF settings can be set for instance, 09:00, 11:00, 13:00, 15:00, 17:00 and 20:00.

When the A/C is OFF, the MELCOTEL sets the room in “Night Set Back” and monitors the room temperature using the remote controller sensor. If the room temperature is too low and below the Low Low Setpoint, for instance 16 °C, the MELCOTEL will restart the A/C to “Low High Setpoint + Heating Deadband” for instance 18 °C+2 °C=20 °C. When the room temperature has reached “Low High Setpoint”, in this example 18 °C the MELCOTEL will switch OFF the A/C to save energy.

The same principle works in cooling. If the room temperature is too high and above High High Setpoint, for instance 27 °C, the MELCOTEL will restart the A/C to “High Low Setpoint - Cooling Deadband” for instance 25 °C-3 °C=22 °C. When the room temperature has reached “High Low Setpoint”, in this example 25 °C the MELCOTEL will switch OFF the A/C to save energy.

At any time, if a window sensor is installed and activated, the MELCOTEL will switch OFF the A/C when the window is opened and the occupied/unoccupied settings will be deactivated.

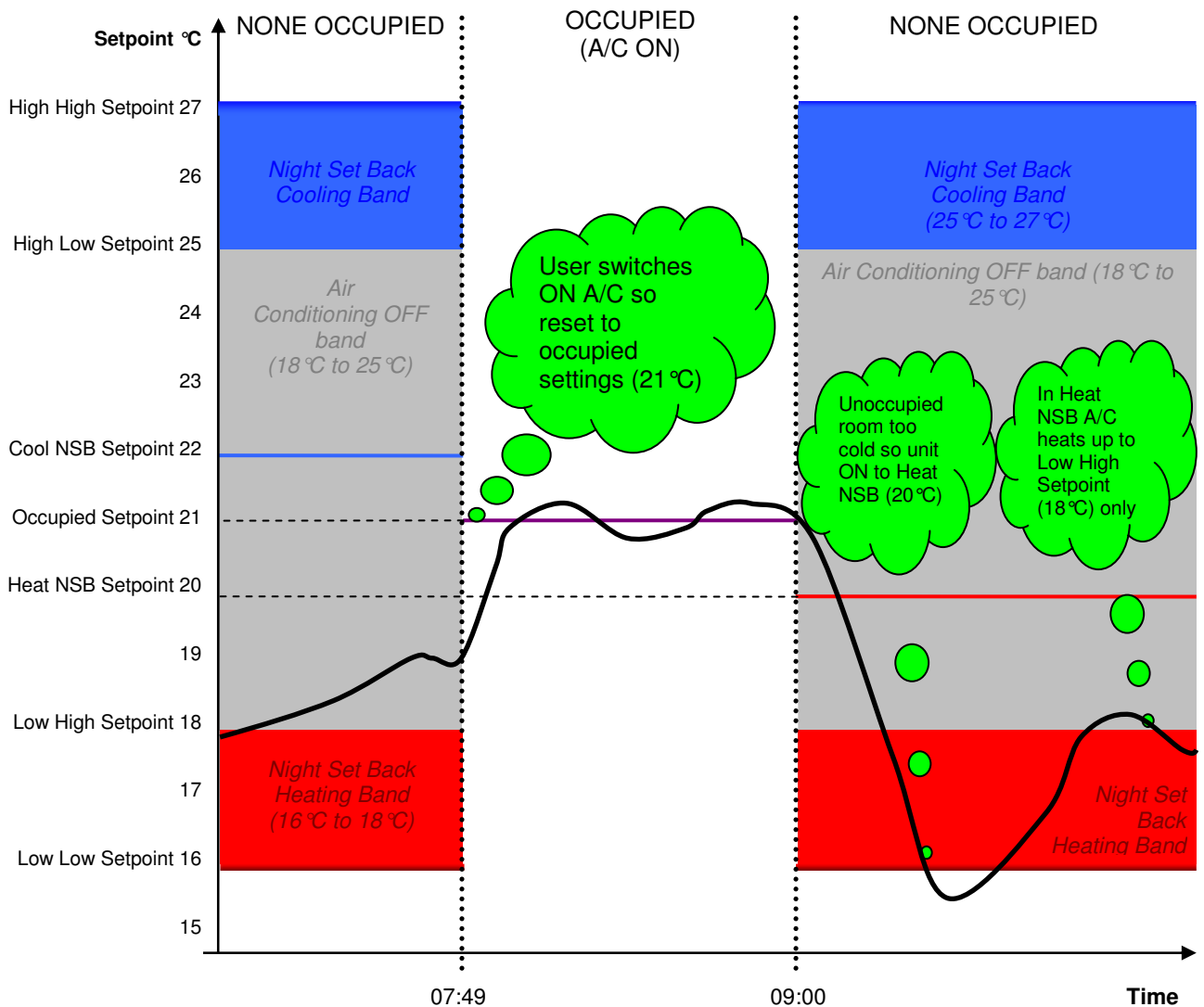

NSB: Night set back

3. Physical Connections

3.1 Power Supply

MELCOTEL requires a 110-230VAC (50-60Hz) power supply capable of supplying 300mA.

3.2 Ethernet Connection

MELCOTEL connects to the G50/GB50/AG150 controllers through its Ethernet port. A network must be formed which contains just the MELCOTEL and between one and five G50/GB50/AG150 controllers, all connected via a hub. No other Ethernet devices should be connected to the network.

If a single G50/GB50/AG150 is to be connected then a crossover Ethernet cable can be used instead of a hub.

An Ethernet connection is searched for upon power up, if no connection is found the Fault LED will switch on and remain on to indicate a fault.

Also if MELCOTEL fails to communicate with any of the enabled G50s for 5 minutes the Fault LED will switch on and remain on to indicate the fault.

⚠ Note:

There are other conditions which cause the Fault LED to remain on, these are described in the Clock Settings chapter.

⚠ Note:

If there is an Ethernet connection error then the connection is retried every 10 seconds. This retry will not occur if the MELCOTEL is communicating with any PC / device over USB, RS232 or RS485. Close any PC utilities which are running and/or disconnect any remote monitoring devices to allow the connection to re-establish.

3.3 Outside Temperature Sensor

An outside temperature sensor can be optionally connected to input *IN01* on the MELCOTEL, this sensor must be a 10K3A1 type thermistor.

When connected, this temperature can be used for outside temperature compensation, lowering or increasing temperature setpoints. If disconnected the MELCOTEL will detect this and perform no compensation.

3.4 Fire Alarm Input

MELCOTEL can be optionally connected to a fire alarm panel and force all indoor units off in the event of the fire alarm being activated. The connection takes the form of a volt free contact on input *IN02* on the MELCOTEL. The connection will be a normally closed contact which will open when the fire alarm is active.

There is no way of enabling or disabling the fire alarm input, so if it is not to be used then a permanent wire link must be placed across both terminals of IN02.

Refer to the Fire Alarm Input chapter for more information.

3.5 Key Switch / Window Contact / Refrigerant Detection System Connections

If applicable to the installation the Key Switch and Window Contact connections with the City Multi indoor unit are as follows:

City Multi Indoor Connector	Pins	Input	State
CN32	1 & 2	Key Switch	Normally Open
CN32	1 & 3	Window Contact or Refrigerant Detection System	Normally Closed

Both Key Switch and Window Contacts or Refrigerant Detection System must be volt free contacts.

A PAC-SA89TA (3 wire adaptor) is required for each indoor unit.

All references to window contact apply to refrigerant detection system. The Melcotel purely monitors the refrigerant detection system status and will only stop the connected indoor unit if required.

4. Power Up

4.1 Normal Power Up

The MELCOTEL will power up and commence operation as soon as power is applied. The green Panel Live LED should switch on and remain on until the power is removed.

If no buttons are held in on power up then a normal power up sequence will occur, this will be signified by a single beep of 500ms duration.

The red Fault LED will switch on initially after power up, but will switch off within 30 seconds if no fault conditions exist.

4.2 Restoring Factory Settings

MELCOTEL holds four sets of factory settings. To restore one of these sets follow the following procedure:

- 1) Power down the MELCOTEL.
- 2) Place a wire link across either input *IN19*, *IN20*, *IN21* or *IN22*.
A link over *IN19* will select default factory settings set 1,
A link over *IN20* will select default factory settings set 2,
A link over *IN21* will select default factory settings set 3,
A link over *IN22* will select default factory settings set 4.

Factory settings details can be found in Appendix 1, 2, 3 and 4.
- 3) Hold in the RESET button and power up MELCOTEL.
- 4) The normal power up beep will be produced, followed by three shorter consecutive beeps. When the three short beeps are produced release the RESET button.
- 5) The selected set of factory settings have been restored, normal operation will commence.

 **Caution:**

If the factory settings are restored then all configuration settings will be lost! MELCOTEL will have to be reconfigured using the MELCOTEL Configuration Manager utility.

4.3 USB / RS485 / RS232 Port Selection

MELCOTEL can communicate with PC applications using either the USB or RS232 port. Remote monitoring devices can be connected using the RS485 port. Only one of these ports can be enabled at any one time.

Upon power up with no buttons held in RS485 is enabled by default. If the SYNC button is held in and there is a wire link present on input IN05 then RS232 is enabled. If SYNC is held in on power up without a wire link present on input IN05 then USB will be enabled.

⚠ Note:

When holding the Sync button in upon power up it must be held in for at least 2 seconds after the power up beep is heard.

Button held in on power up	IN05 wire link	Port enabled
None	N/A	RS485
SYNC	Fitted	RS232
SYNC	Not Fitted	USB

⚠ Note:

IN05 jumper must be set to digital

5. Clock Settings

The correct date and time must be known as MELCOTEL's functionality relies on it (e.g. for season switching, night-time offset etc).

5.1 Clock Synchronisation

G50/GB50/AG150 controllers have their own Real Time Clock (RTC), MELCOTEL utilises this and synchronises it's clock with the clock from the first G50/GB50/AG150 on the network (the first one is named *G50 1* when using the MELCOTEL Config Manager).

It is therefore imperative that:

- *G50 1* is always enabled (this can be done via MELCOTEL Configuration Manager)
- *G50 1* is always connected to the network and powered up.
- *G50 1* is set with the correct time/date.

Periodic synchronisation occurs every 15 minutes to prevent the RTCs from drifting apart. If daylight saving time is required then this must be enabled on *G50 1*. The MELCOTEL has no way of performing daylight saving time on it's own.

Clock synchronisation with *G50 1* will occur:

- Immediately after power up
- Every 15 minutes

Once the date/time is successfully read from *G50 1* it is then validated, any date prior to year 2000 will be assumed invalid. If a valid date/time cannot be obtained then all control functionality will be disabled (except the fire alarm functionality).

 **Note:**

The Fault LED will switch on and remain on if there is a failure to read the clock from *G50 1*, or the value read is invalid. It will remain on until the clock value is valid.

 **Note:**

There are other conditions which cause the Fault LED to remain on, these are described in the Physical Connections chapter.

6. Configuration

6.1 MELCOTEL Configuration Manager

All configuration of MELCOTEL is performed using *MELCOTEL Configuration Manager*.

Configuration settings can be read and written to a connected MELCOTEL device, and there is also an option to save the current configuration to a file. This can be useful if a backup copy of the settings is required, or if the same settings are to be used for a different MELCOTEL.

Also a configuration settings file can be created without connecting to a MELCOTEL device, this means a configuration can be set up off-site and simply loaded into MELCOTEL upon installation.

Important Note:

Install the Configuration Manager and follow the on screen instructions to install the USB drivers **BEFORE** connecting MELCOTEL to the PC.

6.2 Installing MELCOTEL Configuration Manager

Insert the supplied CD and run the setup application, follow the on screen instructions to install all necessary files. The USB drivers will be automatically installed, if a message appears stating the drivers have not passed 'Windows Logo' testing click 'Continue Anyway'.

To run the program go to the Start Menu and navigate to Programs ⇒ MELCOTEL Software ⇒ MELCOTEL Config Manager.

A help file will also be found on the Start Menu.

6.3 Connecting to MELCOTEL

If intending to use USB, make sure the Configuration Manager application is installed before connecting MELCOTEL to the PC. When MELCOTEL is first plugged in you will be asked to install the required drivers. Follow the on screen instructions and let the PC automatically find the drivers it needs.

When connected with the correct drivers installed you can then run the MELCOTEL Config Manager application. If connecting repeatedly fails, try power cycling the MELCOTEL and restarting Config Manager.

When all settings are read they can be modified, written to the MELCOTEL, or saved to a file.

6.4 Global Settings

6.4.1 IP Addresses

The MELCOTEL and each G50/GB50/AG150 have their own IP address to identify themselves on the network. The IP addresses are given in dot-decimal notation, for example 192.168.1.1.

All factory IP address settings are:

<i>MELCOTEL</i>	192.168.1.6	<i>G50 3</i>	192.168.1.3
<i>G50 1</i>	192.168.1.1	<i>G50 4</i>	192.168.1.4
<i>G50 2</i>	192.168.1.2	<i>G50 5</i>	192.168.1.5

It is recommended to use these settings so they match the factory defaults.

6.4.2 G50 Enabled Flags

Between one and five G50/GB50/AG150 devices can be enabled, only enable the ones which are connected to the network. MELCOTEL will try and communicate with all enabled G50/GB50s.

Important Note:

G50 1 must be enabled at all times as MELCOTEL uses that device for clock synchronisation. The other G50/GB50s can be enabled / disabled independently of each other.

6.4.3 Enable Key Card Switches

There are essentially two types of control MELCOTEL can perform, *Key Switch* control and *Non Key Switch* control. Key Switch control should be enabled if each room in the hotel is fitted with key switches which are wired back into the indoor unit on Digital Input 1.

The operation of both of these control types are described elsewhere in this document.

6.4.4 Enable Window Contacts

For both Key Switch and Non Key Switch control types there is the option to enable *Window Contacts*. This should be enabled if each room in the hotel is fitted with window contacts which are wired back into the indoor unit on Digital Input 2.

Essentially, when enabled, if MELCOTEL detects that the window is open it forces the on/off off. The operation is explained in more detail elsewhere in this document.

6.4.5 Global Heating Deadband

Global Heating Deadband is a value in °C and is used when the unit is going into *Low Setback*. Refer to the Low Setback section for a more detailed description.

6.4.6 Global Cooling Deadband

Global Cooling Deadband is a value in °C and is used when the unit is going into *High Setback*. Refer to the High Setback section for a more detailed description.

6.4.7 Force Off Times

The MELCOTEL can optionally be configured to switch the drives of all enabled groups off at certain times of the day. This can be achieved by enabling one or more *Off times*. Each off time comprises of an hour and minute value.

Although it is restricted through the Config Utility, if an invalid time is set it will be ignored. Any off times specified after that will also be ignored.

Note:

The force off feature only applies to non key switch mode of operation. If key switches are enabled the off times can still be set up, but they will be ignored.

⚠ Note:

If a group is in High / Low Setback then the force off times will be ignored.

⚠ Note:

The times must also be entered on chronological order. Any out of order will be ignored.

⚠ Note:

If the *Night-time Offset* feature is enabled and it's time matches one of the force off times, the force off will have priority, hence no Night-time Offset functionality will occur.

6.4.8 Season Start Dates

Up to 4 seasons can optionally be configured, each season having a start month and start day. Each group can have different High/Low Setback setpoints for each season if required.

The seasons must be set in chronological order, but season does not have to start on 1st Jan. If set to date after 1st Jan then the previous season will be assumed.

⚠ Note:

The current season is calculated after a successful clock synchronisation with *G50 1*. The current season is also calculated every 60 minutes, so potentially a season may not be entered until one hour past the season start date.

6.4.9 Night-time Offset

MELCOTEL can be optionally configured to automatically adjust the setpoint of all enabled groups at a certain time of day (typically the early hours of the morning).

The relevant settings are:

Night-time Offset Enable – Enables or disables the feature.

Night-time Offset Time – The time in hours and minutes to activate the offset.

Night-time Offset – The offset in °C to apply.

Night-time Force Off Enable – If enabled the on/off will be switched off instead of having the setpoint adjusted.

If the group is in *Autoheat* or *Heat* modes the setpoint is lowered by offset value.

If the group is in *Autocool* or *Cool* modes the setpoint is increased by the offset value.

The setpoint is not adjusted if in any other mode (i.e. Fan, Dry or Auto).

⚠ Note:

The setpoint will also only be adjusted if the on/off is switched on and not in low / high setback.

⚠ Note:

If one of the *Force Off* times is the same as the Night-time Offset time then the Force Off will have priority.

⚠ Note:

“OFF” in this case means night set back / unoccupied settings.

6.4.10 Season Global Setpoint Offsets

The *Season Global Setpoint Offsets* automatically adjusts the default *On Setpoint* value for every group. For each season, the global setpoint offset can be different but not for each group as it is a global value. For instance:

Season 1 Global Setpoint Offsets 0C
Season 2 Global Setpoint Offsets 1C
Season 3 Global Setpoint Offsets 1C
Season 4 Global Setpoint Offsets 0C

6.4.11 Outside Temperature Offset

A thermistor temperature sensor can be optionally connected to input *IN01* on the MELCOTEL PCB (refer to the *Physical Connections* chapter). MELCOTEL considers any temperature in the range -10°C to 40°C to be valid, it will be assumed no sensor is connected if any value outside this range is detected.

This external temperature is then used to determine an offset, this offset automatically adjusts the default *On Setpoint* value for every group. The value of the offset is configurable for the temperature ranges given below:

External Temperature	Default Value
< -10°C	No default value, offset 0°C always used
>= -10°C and < -5°C	-3°C
>= -5°C and < 5°C	-2°C
>= 15°C and < 15°C	0°C
>= 15°C and < 25°C	2°C
>= 25°C and < 40°C	3°C
>= 40°C	No default value, offset 0°C always used

If the Outside Temperature Offset feature is not required set all values to 0°C.

6.5 Group Settings

There are certain settings which can be set differently for each group.

6.5.1 Group Enabled Flag

Each group on each G50 can be enabled or disabled appropriately. Only enable the groups which are actually set up on each G50, otherwise MELCOTEL will try and read from groups which do not exist.

6.5.2 On Setting (Mode)

At certain times MELCOTEL must set up a group with pre configured *On Settings*. During Key Switch control this is when:

- MELCOTEL detects that a key card has been inserted.
- A key switch is inserted and the on/off has been detected as going from off to on (i.e. the occupant switching the on/off on).

During Non Key Switch control this is when:

- The on/off has been detected as going from off to on (i.e. the occupant switching the on/off on).

The *On Setting (Mode)* is the mode which the group will be forced to then the On Settings are applied.

6.5.3 On Setting (Setpoint)

Similarly to the On Setting (Mode) described previously, the *On Setting (Setpoint)* is the setpoint the group is forced to when the On Settings are applied.

6.5.4 Setback Settings

There are separate setback settings for each group, for each of the four seasons.

6.5.4.1 Low Setback

To avoid the rooms getting too cold a *Low Setback* feature has been implemented into MELCOTEL. If the room temperature drops below a certain point then the on/off will be forced on, the mode will be set to Heat and the setpoint set to a configurable point.

The relevant settings are:

Low Low Setpoint – When a group’s inlet temperature drops below this point Low Setback is activated, for instance 17 °C.

Low High Setpoint – When a group’s inlet temperature increases past this point, for instance 19 °C Low Setback is deactivated and normal operation resumes

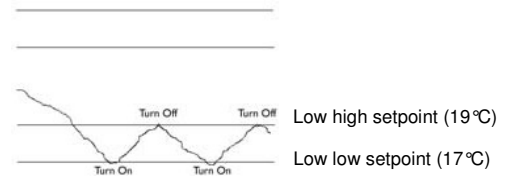

When entering low setback the setpoint is changed to equal the Low High Setpoint value **plus** the *Global Heating Deadband* value. This guarantees the inlet temperature will definitely reach and exceed the Low High Setpoint.

6.5.4.2 High Setback

To avoid the rooms getting too hot a *High Setback* feature has been implemented into MELCOTEL. If the room temperature increases past a certain point then the on/off will be forced on, the mode will be set to Cool and the setpoint set to a configurable point.

The relevant settings are:

High High Setpoint – When a group’s inlet temperature increases past this point High Setback is activated, for instance 27 °C.

High Low Setpoint – When a group’s inlet temperature drops below this point, for instance 25 °C High Setback is deactivated and normal operation resumes.

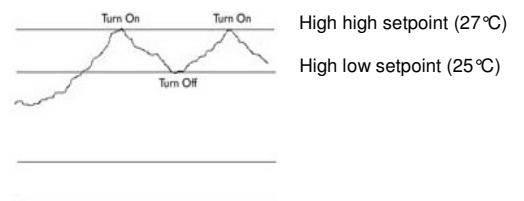

When entering high setback the setpoint is changed to equal the High Low Setpoint value **minus** the *Global Cooling Deadband* value. This guarantees the inlet temperature will definitely reach and decrease past the High Low Setpoint.

⚠ Note:

Under occupied or “OFF” settings, low or high setback will perform. The system will only switch fully OFF under fire alarm conditions.



7. Key Switch Control

Some hotels may have a key switch system installed, where the occupant inserts a key card when they enter the room, and remove it when they leave. This is then used to detect whether the room is occupied or not.

Under key switch control window contacts can be optionally enabled. If window contacts are enabled, under all circumstances the on/off will be forced off while the window is open. If window contacts are not enabled then the window is assumed to be closed for control purposes.

The on/off should always be switched off when a key card is absent. If the on/off is detected as being on when key card is absent it should be immediately forced off. The only time the on/off is on with the key card absent is when Low/High setback is active.

Low and high setback operate only when a key card is not inserted and the window is closed.

During key switch control each group will be in one of the following states:

- *NORMAL* (Key card inserted and window closed)
- *KEY CARD REMOVED* (Window closed)
- *LOW SETBACK* (Key card removed and window closed)
- *HIGH SETBACK* (Key card removed and window closed)
- *WINDOW OPEN*

Figure 6 shows a state diagram for key switch control.

7.1 NORMAL State

If a key card is inserted and window closed the group will be in the NORMAL state.

Because a key card is present this indicates the room is occupied, so the on/off, mode & setpoint can be changed to any value via the remote controller.

If the on/off goes from the off to the on state the group's *On Settings* will also be applied (i.e. when the occupant switches the on/off off and on again).

If the window is opened the on/off will switch off immediately and the state will change to WINDOW OPEN.

Note:

When going from the NORMAL to the WINDOW OPEN state due to the window opening the MELCOTEL remembers whether the on/off was on or off before the window opened. When the window is then closed the on/off resumes it's state from before the window opening.

The LOW SETBACK and HIGH SETBACK states cannot be entered from the NORMAL state, the key card must be removed.

7.2 KEY CARD REMOVED State

If a key card is not inserted the group will be in the KEY CARD REMOVED state.

If in this state the on/off is detected as being on (i.e. the occupant has switched the on/off on) then the on/off will be switched off. This strategy can be deactivated with version 1.10 or above by applying a wire link across input IN03. Note that the jumper setting on IN03 must be set to 0 to 10kΩ / Digital.

If a key card is inserted in this state the on/off will switch on and the group's *On Settings* will be applied. The state will then change to NORMAL.

If the window is opened the on/off will switch off immediately and the state will change to WINDOW OPEN.

If the group's inlet temperature drops below its *Low Low Setpoint* several events will occur:

- 1) The on/off will switch on.
- 2) The mode will be set to Heat.
- 3) The setpoint will be set to the group's *Low High Setpoint* **plus** the *Global Heating Deadband*.
- 4) The state will change to LOW SETBACK.

If the group's inlet temperature increases past its *High High Setpoint* several events will occur:

- 1) The on/off will switch on.
- 2) The mode will be set to Cool.
- 3) The setpoint will be set to the group's *High Low Setpoint* **minus** the *Global Cooling Deadband*.
- 4) The state will change to HIGH SETBACK.

7.3 WINDOW OPEN State

If the window is open the on/off will always be forced off. If in this state the on/off is detected as being on (i.e. the occupant has switched the on/off on) then the on/off will be switched off.

The only way to get out of this state is to close the window.

If the window was opened in the NORMAL state then the state of the on/off is remembered from just before the window opening. If the window then closes with a key card inserted the on/off will resume it's state from before the window opened. The state will then change to NORMAL.

If the window closes with a key card inserted but the previous state was not NORMAL then the on/off will be switched on. The state will then change to NORMAL.

7.4 LOW SETBACK State

The LOW SETBACK state can only be entered from the KEY CARD REMOVED state when the group's inlet temperature drops below the group's *Low Low Setpoint*.

If the inlet temperature exceeds the group's *Low High Setpoint* then the on/off will be forced off and the state will change to KEY CARD REMOVED.

If a key card is inserted the on/off will switch on and the group's *On Settings* will be applied. The state will then change to NORMAL.

If the window is opened the on/off will switch off immediately and the state will change to WINDOW OPEN.

While in the LOW SETBACK state any of the settings can be changed (i.e. on/off, mode, setpoint). Every 15 minutes MELCOTEL will check which groups are in Low Setback and if any settings have been changed then they will be forced back to what they should be for Low Setback.

Night-time Offset will be ignored while in the LOW SETBACK state.

Force Off times will be ignored while in the LOW SETBACK state.

7.5 HIGH SETBACK State

The HIGH SETBACK state can only be entered from the KEY CARD REMOVED state when the group's inlet temperature increases past the group's *High High Setpoint*.

If the inlet temperature drops the group's *High Low Setpoint* then the on/off will be forced off and the state will change to KEY CARD REMOVED.

If a key card is inserted the on/off will switch on and the group's *On Settings* will be applied. The state will then change to NORMAL.

If the window is opened the on/off will switch off immediately and the state will change to WINDOW OPEN.

While in the HIGH SETBACK state any of the settings can be changed (i.e. on/off, mode, setpoint). Every 15 minutes MELCOTEL will check which groups are in High Setback and if any settings have been changed then they will be forced back to what they should be for High Setback.

Night-time Offset will be ignored while in the HIGH SETBACK state.

Force Off times will be ignored while in the HIGH SETBACK state.

8. Non Key Switch Control

Some hotels do not have a key switch system installed, hence it is impossible to know all the time whether the room is occupied or not.

Under non key switch control window contacts can be optionally enabled. If window contacts are enabled, under all circumstances the on/off will be forced off while the window is open. If window contacts are not enabled then the window is assumed to be closed for control purposes.

Low and high setback can start at any time while the window is closed.

During non key switch control each group will be in one of the following states:

- *NORMAL* (Window closed)
- *LOW SETBACK* (Window closed)
- *HIGH SETBACK* (Window closed)
- *WINDOW OPEN*

Figure 7 shows a state diagram for non key switch control.

8.1 NORMAL State

If the window is closed and Low or High Setback is not active then the group will be in the NORMAL state.

If the on/off goes from the off to the on state the group's *On Settings* will be applied (i.e. when the occupant switches the on/off off and on again).

If the window is opened the on/off will switch off immediately and the state will change to WINDOW OPEN.

Note:

When going from the NORMAL to the WINDOW OPEN state due to the window opening the MELCOTEL remembers whether the on/off was on or off before the window opened. When the window is then closed the on/off resumes it's state from before the window opening.

If the group's inlet temperature drops below its *Low Low Setpoint* several events will occur:

- 5) The on/off will switch on.
- 6) The mode will be set to Heat.
- 7) The setpoint will be set to the group's *Low High Setpoint plus the Global Heating Deadband*.
- 8) The state will change to LOW SETBACK.

If the group's inlet temperature increases past its *High High Setpoint* several events will occur:

- 5) The on/off will switch on.
- 6) The mode will be set to Cool.
- 7) The setpoint will be set to the group's *High Low Setpoint minus the Global Cooling Deadband*.
- 8) The state will change to HIGH SETBACK.

8.2 WINDOW OPEN State

If the window is open the on/off will always be forced off. If in this state the on/off is detected as being on (i.e. the occupant has switched the on/off on) then the on/off will be switched off.

The only way to get out of this state is to close the window.

If the window was opened in the NORMAL state then the state of the on/off is remembered from just before the window opening. If the window then closes the on/off will resume it's state from before the window opened. The state will then change to NORMAL.

8.3 LOW SETBACK State

The LOW SETBACK state can only be entered from the NORMAL state when the group's inlet temperature drops below the group's *Low Low Setpoint*.

If the inlet temperature exceeds the group's *Low High Setpoint* then the on/off will be forced off and the state will change to NORMAL.

If the window is opened the on/off will switch off immediately and the state will change to WINDOW OPEN.

While in the LOW SETBACK state, if any of the on/off, mode or setpoint settings are detected as having changed, it is assumed that the room is occupied and the NORMAL state will be entered. At this point both LOW SETBACK and HIGH SETBACK will be inhibited for 60 minutes.

Night-time Offset will be ignored while in the LOW SETBACK state.

Force Off times will be ignored while in the LOW SETBACK state.

8.4 HIGH SETBACK State

The HIGH SETBACK state can only be entered from the NORMAL state when the group's inlet temperature increases past the group's *High High Setpoint*.

If the inlet temperature drops below the group's *High Low Setpoint* then the on/off will be forced off and the state will change to NORMAL.

If the window is opened the on/off will switch off immediately and the state will change to WINDOW OPEN.

While in the HIGH SETBACK state, if any of the on/off, mode or setpoint settings are detected as having changed, it is assumed that the room is occupied and the NORMAL state will be entered. At this point both LOW SETBACK and HIGH SETBACK will be inhibited for 60 minutes.

Night-time Offset will be ignored while in the LOW SETBACK state.

Force Off times will be ignored while in the LOW SETBACK state.

9. Fire Alarm Input

MELCOTEL can be optionally connected to a fire alarm panel and force all indoor units off in the event of the fire alarm being activated. The connection takes the form of a volt free contact on input *IN02* on the MELCOTEL. The connection will be a normally closed contact which will open when the fire alarm is active.

There is no way of enabling or disabling the fire alarm input, so if it is not to be used then a permanent wire link must be placed across both terminals of *IN02*.

When the fire alarm activates (input *IN02* becomes open circuit) the MELCOTEL will repeatedly force all enabled groups off. All other control functionality will be disabled until the fire alarm is deactivated.

The Fault LED will flash once a second to indicate the fire alarm is active, this flash will occur regardless of whether the Fault LED was on or off beforehand. The flashing will stop when the fire alarm is deactivated.

10. MELCOTEL and M2M (Remote Monitoring)

10.1 Introduction

The MELCOTEL can be connected to the Mini M2M for monitoring purposes only using the RS485 network (ABS). Figure 8 shows the wiring diagram.

This function will enable the end user and the contractor to monitor:

- On/off
- Mode
- Room temperature
- Setpoint
- Set back status (on low, on high, none)
- Key card status
- Window sensor status
- External temperature (when supplied sensor is installed)
- Communication status between MELCOTEL, G50/GB50/AG150 and indoor units
- Key card enabled status
- Window sensor enabled status

The M2M Modbus slave use for Melcotel should be "Melcotel V1.07 (must use V2.52 M2M)".

10.2 MELCOTEL and M2M

Screenshot of the dashboard

The screenshot displays the 'Monitor/Operation' interface for 'Maxi M2M - Melcotel'. The interface includes a navigation bar with 'Status' and 'Logout' links, and a 'MITSUBISHI ELECTRIC' logo. The main content area is titled 'Status' and contains a table with the following columns: Room, Drive, Mode, Inlet Temp, Set Point, Set Back, Key, and Window. The table lists the status for eight rooms. Below the table, there are system parameters: External Temp (13 °C), Communication (OK), Keys Enabled (No), and Window Contacts Enabled (No). The footer shows the last logon time as 15/05/2009 10:37:46 and the next expected logon time as 15/05/2009 11:02:46.

Room	Drive	Mode	Inlet Temp	Set Point	Set Back	Key	Window
Room 1 Status	Off	Auto	22°C	20°C	None	Presen	
Room 2 Status	Off	Auto	21°C	20°C	None	Presen	
Room 3 Status	Off	Auto	23°C	20°C	None	Presen	
Room 4 Status	Off	Auto	22°C	20°C	None	Presen	
Room 5 Status	Off	Auto	23°C	20°C	None	Presen	
Room 6 Status	Off	Auto	20°C	20°C	None	Presen	
Room 7 Status	Off	Auto	22°C	20°C	None	Presen	
Room 8 Status	Off	Auto	22°C	20°C	None	Presen	

External Temp: 13 °C Keys Enabled: No
Communication: OK Window Contacts Enabled: No

Last logon: 15/05/2009 10:37:46. Next expected logon: 15/05/2009 11:02:46

10.3 MELCOTEL and M2M using window contact

Screenshot of the dashboard

Monitor/Operation | Maxi M2M - Melcotel | MITSUBISHI ELECTRIC

Status | Logout | Administration

Status

Room	Drive	Mode	Inlet Temp	Set Point	Set Back	Key	Window
Room 1 Status	Off	Auto	22°C	20°C	None	Present	Closed
Room 2 Status	Off	Auto	21°C	20°C	None	Present	Closed
Room 3 Status	Off	Auto	23°C	20°C	None	Present	Closed
Room 4 Status	Off	Auto	22°C	20°C	None	Present	Closed
Room 5 Status	Off	Auto	23°C	20°C	None	Present	Closed
Room 6 Status	Off	Auto	20°C	20°C	None	Present	Closed
Room 7 Status	Off	Auto	22°C	20°C	None	Present	Closed
Room 8 Status	Off	Auto	22°C	20°C	None	Present	Closed

External Temp: 13 °C Keys Enabled: No
 Communication: OK Window Contacts Enabled: No

Last logon: 15/05/2009 10:37:46. Next expected logon: 15/05/2009 11:02:46

10.4 MELCOTEL and M2M using refrigerant detection system

When using refrigerant detection system the M2M Modbus slave used for Melcotel should be "Melcotel Leak Detection".

Screenshot of the dashboard

M2M Web Portal | SN2837E3 | MITSUBISHI ELECTRIC

Status | Contact Us | Logout | Administration

Status

Room	Drive	Mode	Inlet Temp	Set Point	Set Back	Key	Leak Detection
ROOM 1-005	Off	Auto	25°C	21°C	None	NotPresent	NoLeakDetected
ROOM 1-006	On	AutoHeat	24°C	21°C	None	Present	NoLeakDetected
ROOM 1-004	On	Auto	24°C	21°C	None	Present	NoLeakDetected
ROOM 1-003	Off	Auto	26°C	22°C	None	NotPresent	NoLeakDetected
ROOM 2-005	Off	Auto	23°C	21°C	None	NotPresent	NoLeakDetected
ROOM 2-006	Off	Auto	24°C	21°C	None	NotPresent	NoLeakDetected
ROOM 2-004	Off	Auto	24°C	19°C	None	NotPresent	NoLeakDetected
ROOM 2-003	Off	Auto	24°C	19°C	None	NotPresent	NoLeakDetected

External Temp: 53 °C Keys Enabled: Yes Any Leaks Detected: Yes
 Communication: OK Leak Detection Enabled: Yes Faults with the A/C system will not be reported

Last logon: 14/09/2011 11:25:41. Next expected logon: 14/09/2011 11:50:41

11. Applicable Air Conditioning Models

11.1 Using key card and / or window sensor

The MELCOTEL interface when used with the key card and / or the window sensor can only be used with the following outdoor models:

- P**Y-YGM-A (R410A)
- P**Y-YHM-A (R410A)
- P**Y-YJM-A (R410A)

⚠ Note

The MELCOTEL does not support the AG150 expansion controller (PAC-YG50ECA).

11.2 NOT Using key card and / or window sensor

The MELCOTEL interface when NOT used with the key card and / or the window sensor can only be used with the following outdoor models:

- P**Y-YMF-B (R22)
- P**Y-YMF-C (R407C)
- P**Y-YME-A (R407C)
- P**Y-YGM-A (R410A)
- P**Y-YHM-A (R410A)
- P**Y-YJM-A (R410A)

⚠ Note

The MELCOTEL does not support the AG150 expansion controller (PAC-YG50ECA).

12. Important Notes

⚠ Please note that:

- **The MELCOTEL cannot be used with Splits systems**
- The MELCOTEL can only be used with City Multi systems
- The MELCOTEL when used with key card and / or window sensor can only be used with **R410A City Multi systems**

- The HUB and network cable are not supplied by Mitsubishi Electric
- Network cables must be patch network cable and NOT cross over
- Each network cable must be a maximum of 100m long

- The web monitor PIN code must be activated when using G50
- The GB50 license pack PIN code must be activated when using GB50
- The AG150-Basic PIN code must be activated when using AG-150
- **The GB50/G50/AG150 date/time must be set properly as the MELCOTEL reads the date/time from the first GB50/G50/AG150**

- **The DIP switch 1-1 must be set ON for each indoor unit**
- **The DIP switch 1-9 must be set ON for each indoor unit**
- **The DIP switch 1-10 must be set ON for each indoor unit**

- The IN01 input on the MELCOTEL is set to Thermistor and should not be changed
- The IN02 input on the MELCOTEL is set to Digital and should not be changed
- The IN05 input on the MELCOTEL is set to Digital and should not be changed
- The IN19 input on the MELCOTEL is set to Digital and should not be changed
- The IN20 input on the MELCOTEL is set to Digital and should not be changed
- The IN21 input on the MELCOTEL is set to Digital and should not be changed
- The IN22 input on the MELCOTEL is set to Digital and should not be changed

- The MELCOTEL can be connected to the Mini M2M for monitoring purposes ONLY
- The MELCOTEL and the Mini M2M cannot be displayed on the M2M web portal but only using a dashboard

- The MELCOTEL cannot control more than 250 indoor units
- The MELCOTEL cannot control more than 5 GB50s or 5 G50s or 5 AG150 (not using the PAC-YG50ECA)
- **The MELCOTEL does not support the AG150 expansion controller (PAC-YG50ECA)**

- The speed of the MELCOTEL indoor unit scanning will depend of the number of indoor units

- The MELCOTEL outdoor sensor supplied should not be installed in direct sun light

- **The commissioning tools MUST be installed before connecting the MELCOTEL to the PC**
- To activate the USB port on the MELCOTEL, power up with the SYNC button held in. Release the SYNC button 3 seconds after the power up beep is heard
- It is recommended to power cycle the MELCOTEL when the setup has been completed

13. Troubleshooting

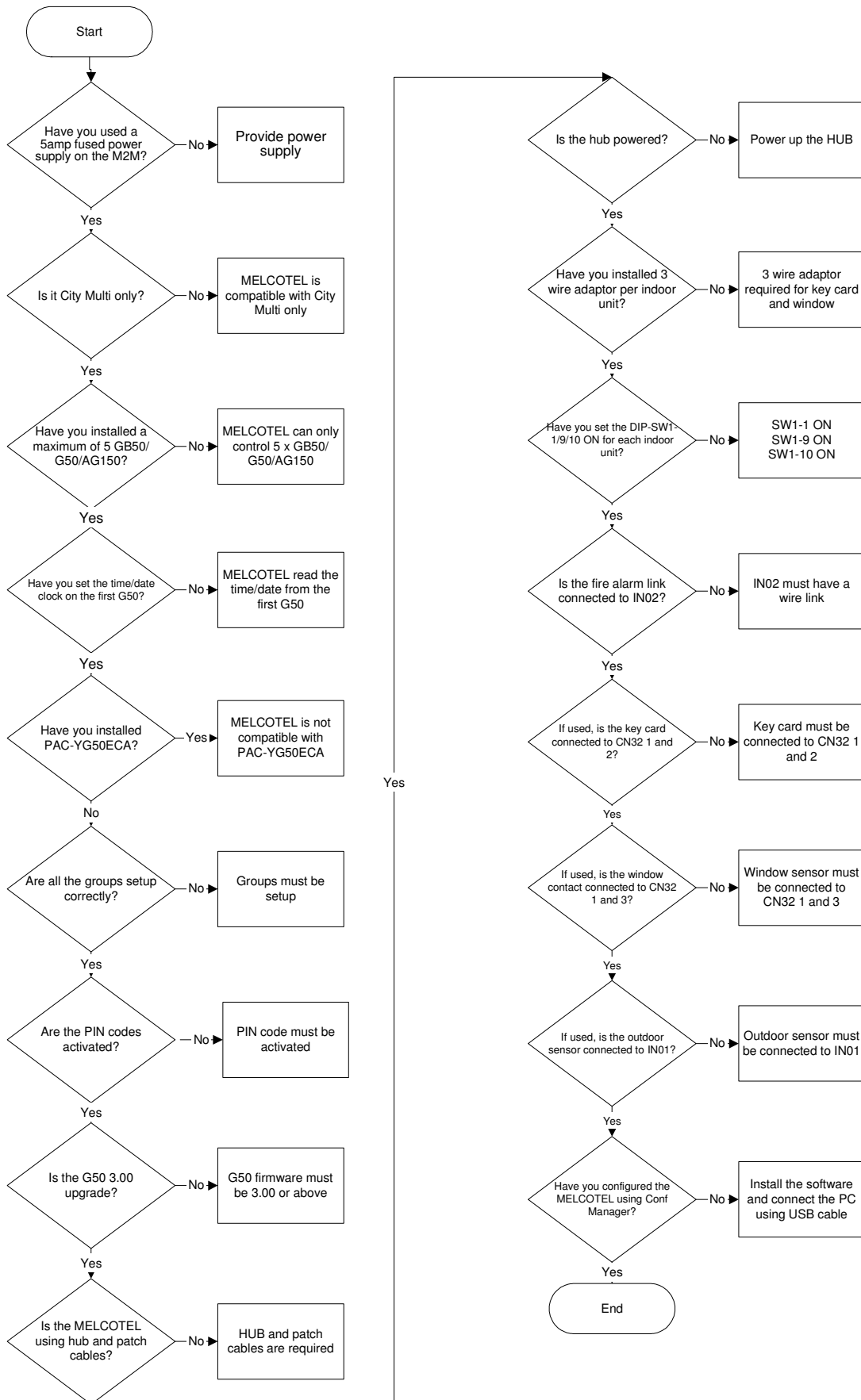

14. Appendix

14.1 Appendix 1 – User settings 1

Melcotel IP Address = 192.168.1.6
G50 1 IP Address = 192.168.1.1
G50 2 IP Address = 192.168.1.2
G50 3 IP Address = 192.168.1.3
G50 4 IP Address = 192.168.1.4
G50 5 IP Address = 192.168.1.5

G50 1 Enabled = **TRUE**
G50 2 Enabled = **TRUE**
G50 3 Enabled = **TRUE**
G50 4 Enabled = **TRUE**
G50 5 Enabled = **TRUE**

Key Switches Enable = **TRUE**
Window Contacts Enable = **FALSE**

Off Time 1 = 09:00, Enabled = **FALSE**
Off Time 2 = 11:00, Enabled = **FALSE**
Off Time 3 = 13:00, Enabled = **FALSE**
Off Time 4 = 15:00, Enabled = **FALSE**
Off Time 5 = 17:00, Enabled = **FALSE**
Off Time 6 = 19:00, Enabled = **FALSE**

Global Heating Deadband = 3 °C
Global Cooling Deadband = 2 °C

Nighttime Off Enable = **TRUE**;
Nighttime Off Time = 02:00
Nighttime Offset = 2 °C;
Nighttime Force Off = **FALSE**

Spring Start = 01/02
Summer Start = 01/05
Autumn Start = 01/07
Winter Start = 01/10

Season 1 Global Setpoint Offset = 0 °C
Season 2 Global Setpoint Offset = 2 °C
Season 3 Global Setpoint Offset = 2 °C
Season 4 Global Setpoint Offset = 0 °C

Outside Temperature Range Offset 1 (<-5 °C) = -2
Outside Temperature Range Offset 2 (-5 °C to 5 °C) = -1
Outside Temperature Range Offset 3 (5 °C to 15 °C) = 0
Outside Temperature Range Offset 4 (15 °C to 25 °C) = 1
Outside Temperature Range Offset 5 (>25 °C) = 2

For all Groups:

On Settings Mode Season 1 = AUTO
On Settings Mode Season 2 = AUTO
On Settings Mode Season 3 = AUTO
On Settings Mode Season 4 = AUTO
On Settings Setpoint = 22°C

For all Groups:

Spring Low Setback Lower Setpoint = 17
Spring Low Setback Upper Setpoint = 19
Summer Low Setback Lower Setpoint = 17
Summer Low Setback Upper Setpoint = 19
Autumn Low Setback Lower Setpoint = 17
Autumn Low Setback Upper Setpoint = 19
Winter Low Setback Lower Setpoint = 17
Winter Low Setback Upper Setpoint = 19

Spring High Setback Lower Setpoint = 25
Spring High Setback Upper Setpoint = 27
Summer High Setback Lower Setpoint = 25
Summer High Setback Upper Setpoint = 27
Autumn High Setback Lower Setpoint = 25
Autumn High Setback Upper Setpoint = 27
Winter High Setback Lower Setpoint = 25
Winter High Setback Upper Setpoint = 27

14.2 Appendix 2 – User settings 2

Melcotel IP Address = 192.168.1.6
G50 1 IP Address = 192.168.1.1
G50 2 IP Address = 192.168.1.2
G50 3 IP Address = 192.168.1.3
G50 4 IP Address = 192.168.1.4
G50 5 IP Address = 192.168.1.5

G50 1 Enabled = **TRUE**
G50 2 Enabled = **TRUE**
G50 3 Enabled = **TRUE**
G50 4 Enabled = **TRUE**
G50 5 Enabled = **TRUE**

Key Switches Enable = **FALSE**
Window Contacts Enable = **FALSE**

Off Time 1 = 08:00, Enabled = **TRUE**
Off Time 2 = 10:00, Enabled = **TRUE**
Off Time 3 = 12:00, Enabled = **TRUE**
Off Time 4 = 14:00, Enabled = **TRUE**
Off Time 5 = 16:00, Enabled = **TRUE**
Off Time 6 = 20:00, Enabled = **TRUE**

Global Heating Deadband = 3°C
Global Cooling Deadband = 2°C

Nighttime Off Enable = **TRUE**;
Nighttime Off Time = 01:00
Nighttime Offset = 0°C;
Nighttime Force Off = **TRUE**

Spring Start = 01/03
Summer Start = 01/06
Autumn Start = 01/09
Winter Start = 01/12

Season 1 Global Setpoint Offset = 0°C
Season 2 Global Setpoint Offset = 0°C
Season 3 Global Setpoint Offset = 0°C
Season 4 Global Setpoint Offset = 0°C

Outside Temperature Range Offset 1 (<-5°C) = -1
Outside Temperature Range Offset 2 (-5°C to 5°C) = -1
Outside Temperature Range Offset 3 (5°C to 15°C) = 0
Outside Temperature Range Offset 4 (15°C to 25°C) = 1
Outside Temperature Range Offset 5 (>25°C) = 2

For all Groups:

On Settings Mode Season 1 = AUTO
On Settings Mode Season 2 = AUTO
On Settings Mode Season 3 = AUTO
On Settings Mode Season 4 = AUTO
On Settings Setpoint = 20°C

For all Groups:

Spring Low Setback Lower Setpoint = 15
Spring Low Setback Upper Setpoint = 17
Summer Low Setback Lower Setpoint = 15
Summer Low Setback Upper Setpoint = 17
Autumn Low Setback Lower Setpoint = 15
Autumn Low Setback Upper Setpoint = 17
Winter Low Setback Lower Setpoint = 15
Winter Low Setback Upper Setpoint = 17

Spring High Setback Lower Setpoint = 27
Spring High Setback Upper Setpoint = 29
Summer High Setback Lower Setpoint = 27
Summer High Setback Upper Setpoint = 29
Autumn High Setback Lower Setpoint = 27
Autumn High Setback Upper Setpoint = 29
Winter High Setback Lower Setpoint = 27
Winter High Setback Upper Setpoint = 29

14.3 Appendix 3 – User settings 3

Melcotel IP Address = 192.168.1.6
G50 1 IP Address = 192.168.1.1
G50 2 IP Address = 192.168.1.2
G50 3 IP Address = 192.168.1.3
G50 4 IP Address = 192.168.1.4
G50 5 IP Address = 192.168.1.5

G50 1 Enabled = **TRUE**
G50 2 Enabled = **FALSE**
G50 3 Enabled = **FALSE**
G50 4 Enabled = **FALSE**
G50 5 Enabled = **FALSE**

Key Switches Enable = **FALSE**
Window Contacts Enable = **FALSE**

Off Time 1 = 09:00, Enabled = **TRUE**
Off Time 2 = 11:00, Enabled = **TRUE**
Off Time 3 = 13:00, Enabled = **TRUE**
Off Time 4 = 15:00, Enabled = **TRUE**
Off Time 5 = 17:00, Enabled = **TRUE**
Off Time 6 = 19:00, Enabled = **TRUE**

Global Heating Deadband = 3°C
Global Cooling Deadband = 2°C

Nighttime Off Enable = **FALSE**;
Nighttime Off Time = 00:00
Nighttime Offset = 0°C;
Nighttime Force Off = **TRUE**

Spring Start = 01/03
Summer Start = 01/06
Autumn Start = 01/09
Winter Start = 01/12

Season 1 Global Setpoint Offset = 0°C
Season 2 Global Setpoint Offset = 0°C
Season 3 Global Setpoint Offset = 0°C
Season 4 Global Setpoint Offset = 0°C

Outside Temperature Range Offset 1 (<-5°C) = -3
Outside Temperature Range Offset 2 (-5°C to 5°C) = -2
Outside Temperature Range Offset 3 (5°C to 15°C) = 0
Outside Temperature Range Offset 4 (15°C to 25°C) = 2
Outside Temperature Range Offset 5 (>25°C) = 3

For all Groups:

On Settings Mode Season 1 = AUTO
On Settings Mode Season 2 = AUTO
On Settings Mode Season 3 = AUTO
On Settings Mode Season 4 = AUTO
On Settings Setpoint = 21°C

For all Groups:

Spring Low Setback Lower Setpoint = 16
Spring Low Setback Upper Setpoint = 18
Summer Low Setback Lower Setpoint = 17
Summer Low Setback Upper Setpoint = 19
Autumn Low Setback Lower Setpoint = 17
Autumn Low Setback Upper Setpoint = 19
Winter Low Setback Lower Setpoint = 16
Winter Low Setback Upper Setpoint = 18

Spring High Setback Lower Setpoint = 25
Spring High Setback Upper Setpoint = 27
Summer High Setback Lower Setpoint = 25
Summer High Setback Upper Setpoint = 27
Autumn High Setback Lower Setpoint = 25
Autumn High Setback Upper Setpoint = 27
Winter High Setback Lower Setpoint = 25
Winter High Setback Upper Setpoint = 27

14.4 Appendix 4 – User settings 4

Melcotel IP Address = 192.168.1.6
G50 1 IP Address = 192.168.1.1
G50 2 IP Address = 192.168.1.2
G50 3 IP Address = 192.168.1.3
G50 4 IP Address = 192.168.1.4
G50 5 IP Address = 192.168.1.5

G50 1 Enabled = **TRUE**
G50 2 Enabled = **FALSE**
G50 3 Enabled = **FALSE**
G50 4 Enabled = **FALSE**
G50 5 Enabled = **FALSE**

Key Switches Enable = **TRUE**
Window Contacts Enable = **FALSE**

Off Time 1 = 09:00, Enabled = **FALSE**
Off Time 2 = 11:00, Enabled = **FALSE**
Off Time 3 = 13:00, Enabled = **FALSE**
Off Time 4 = 15:00, Enabled = **FALSE**
Off Time 5 = 17:00, Enabled = **FALSE**
Off Time 6 = 19:00, Enabled = **FALSE**

Global Heating Deadband = 3°C
Global Cooling Deadband = 2°C

Nighttime Off Enable = **FALSE**;
Nighttime Off Time = 00:00
Nighttime Offset = 0°C;
Nighttime Force Off = **TRUE**

Spring Start = 01/03
Summer Start = 01/06
Autumn Start = 01/09
Winter Start = 01/12

Season 1 Global Setpoint Offset = 0°C
Season 2 Global Setpoint Offset = 0°C
Season 3 Global Setpoint Offset = 0°C
Season 4 Global Setpoint Offset = 0°C

Outside Temperature Range Offset 1 (<-5°C) = -3
Outside Temperature Range Offset 2 (-5°C to 5°C) = -2
Outside Temperature Range Offset 3 (5°C to 15°C) = 0
Outside Temperature Range Offset 4 (15°C to 25°C) = 2
Outside Temperature Range Offset 5 (>25°C) = 3

For all Groups:

On Settings Mode Season 1 = AUTO
On Settings Mode Season 2 = AUTO
On Settings Mode Season 3 = AUTO
On Settings Mode Season 4 = AUTO
On Settings Setpoint = 21 °C

For all Groups:

Spring Low Setback Lower Setpoint = 16
Spring Low Setback Upper Setpoint = 18
Summer Low Setback Lower Setpoint = 17
Summer Low Setback Upper Setpoint = 19
Autumn Low Setback Lower Setpoint = 17
Autumn Low Setback Upper Setpoint = 19
Winter Low Setback Lower Setpoint = 16
Winter Low Setback Upper Setpoint = 18

Spring High Setback Lower Setpoint = 25
Spring High Setback Upper Setpoint = 27
Summer High Setback Lower Setpoint = 25
Summer High Setback Upper Setpoint = 27
Autumn High Setback Lower Setpoint = 25
Autumn High Setback Upper Setpoint = 27
Winter High Setback Lower Setpoint = 25
Winter High Setback Upper Setpoint = 27



This product is designed and intended for use in the residential, commercial and light-industrial environment.

The product at hand is based on the following EU regulations:

- Low Voltage Directive 73/23/EEC
- Electromagnetic Compatibility Directive 89/336/EEC

Please be sure to put the contact address/telephone number on this manual before handing it to the customer.

mitsubishi electric uk

MITSUBISHI ELECTRIC UK, TRAVELLERS LANE, HATFIELD HERTFORDSHIRE, AL10 8XB