



**Air-conditioner Control System Optional Parts
Mounting attachment A type for use with AG-150A
PAC-YG85KTB
Installation Manual**

Applicable Model	Centralized Controller AG-150A
------------------	--

1 Safety Precautions

- Before installing the Mounting attachment A type, please read the following safety precautions carefully to ensure proper installation.
- Observe the following precautions to ensure safety.
- The following symbols are used in this manual to indicate the type and severity of potential consequences that may result when given instructions are not followed exactly as stated.

WARNING	Indicates a risk of death or serious injury.
CAUTION	Indicates a risk of injury or damage to the product.

- After the completion of installation, perform a test run to confirm proper operation.
- Retain this manual for future reference. When the unit is reinstalled or repaired, make this manual available to those who provide these services. Make sure that the manual is passed on to any future air condition system users.





WARNING	
<p>Only a dealer or qualified technician should replace the unit. Improper replacement by an unqualified person may result in electric shock or fire.</p>	<p>Install the Mounting attachment A type properly according to the instructions detailed in this Installation Manual. Improper installation by an unqualified person may result in electric shock or fire.</p>
<p>The Mounting attachment A type should be installed on a surface that is strong enough to support the weight of the unit. If the Mounting attachment A type is installed on a surface that lacks the strength to support it, it may fall and cause injury.</p>	<p>Electric work must be performed by authorized personnel according to the local regulations and the instructions detailed in the Installation Manual. Inadequate circuit capacity or improper installation may result in electric shock or fire.</p>
<p>Do not attempt to modify or repair the Mounting attachment A type. Modification or improper repair may result in electric shock or fire. Consult your dealer when repairs are necessary.</p>	<p>Ask your dealer or an authorized technician to move the Mounting attachment A type. Improper installation by an unqualified person may result in electric shock or fire. Consult your dealer or a qualified technician.</p>

CAUTION	
<p>Do not install the Mounting attachment A type where there is a risk of leaking flammable gas. If the leaked gas accumulates around the Mounting attachment A type, it may ignite and cause an explosion.</p>	<p>Do not install this Mounting attachment A type in a place that has the potential for steam, such as a bathroom or kitchen. Steam may cause an electric shock or a unit malfunction.</p>
<p>Do not use the Mounting attachment A type in an environment that has high concentrations of oil, steam, or sulfuric gas. These substances may have adverse effects on the performance of the Mounting attachment A type or damage its parts.</p>	<p>Do not install this Mounting attachment A type where an acid, alkaline solution, or special chemical spray is used frequently to avoid electric shock or malfunction.</p>
<p>Seal the wire access holes with putty to prevent dew, water, and insects from entering to avoid electric shock.</p>	<p>Keep the cables from coming in direct contact with the edges of the wire access holes. If the cables are damaged, they may cause electric shock or fire.</p>
	<p>This Mounting attachment A type is for exclusive use with the AG-150A and cannot be used with other devices.</p>

2 Parts List

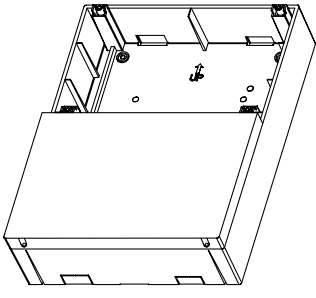
The Installation Manual and the parts listed below are included with the package.

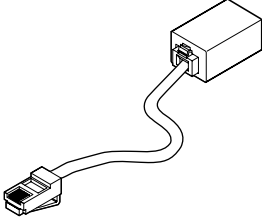
* Leave the Mounting attachment A type in the package until ready to install to protect it from damage.

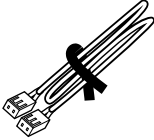
Name	① Mounting attachment A type (PAC-YG85KTB)	② AG-150A mounting screws	③ Power supply unit (PAC-SC51KUA) mounting screws	④ LAN link-up cable
Quantity	1	4	4	1
Shape		Roundhead screws M4x16 	Roundhead screws M4x10 	
Name	⑤ Power cable for the power supply unit (PAC-SC51KUA) (CN2)	⑥ M-NET cable for the power supply unit (PAC-SC51KUA) (CN1)		
Quantity	1	1		
Shape				

3 Field-supplied parts

The following parts are necessary to mount the Mounting attachment A type (PAC-YG85KTB) and on the wall.

Name	① Wall mounting screws (M5)
Quantity	6

Use screws that are suitable for the wall type.

The weight of the AG-150A including the Mounting attachment A type (PAC-YG85KTB) and power supply unit (PAC-SC51KUA) is 5.1 kg (12 lbs).

(The weight of the Mounting attachment A type is 1.7 kg (4 lbs.) by itself.)

Use screws with the head size of between 8 and 11.8 mm (3/8 and 1/2 in).

4 External Dimensions

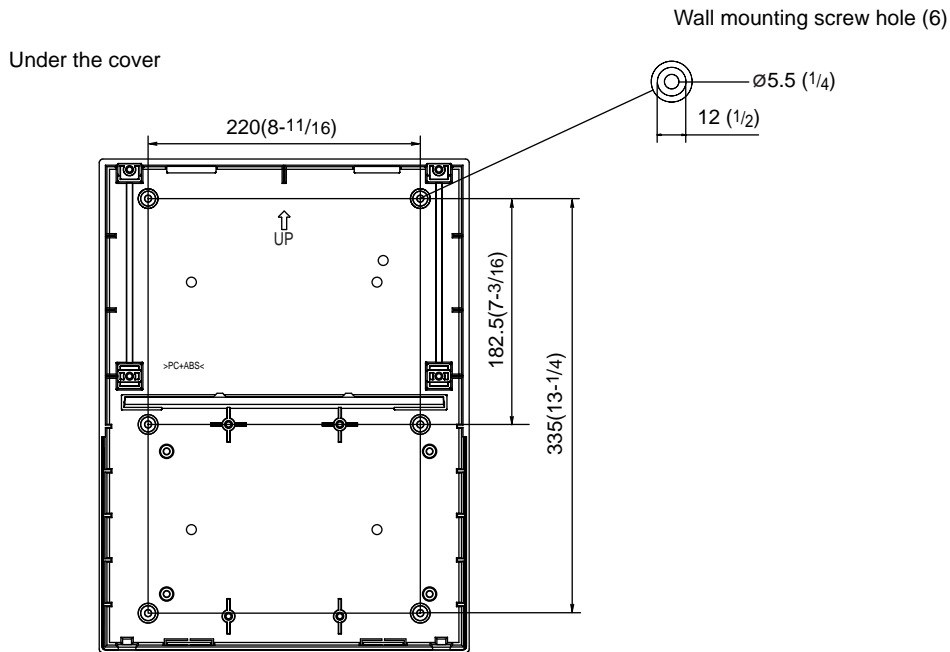
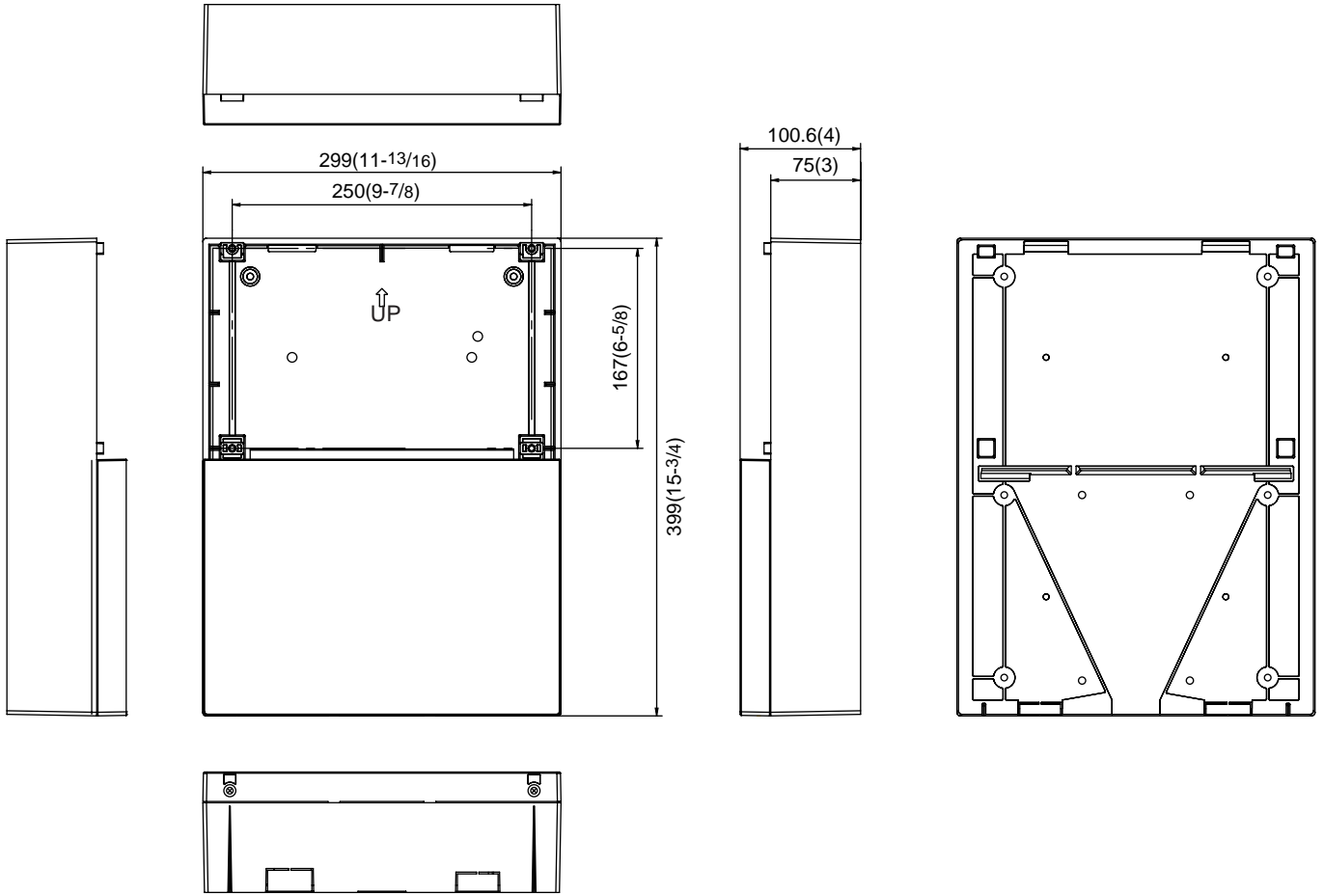

Unit: mm (in)

5 | Selecting an Installation Site

1. Required installation space

Install the Mounting attachment A type (PAC-YG85KTB) where the space indicated in the figure below can be secured.

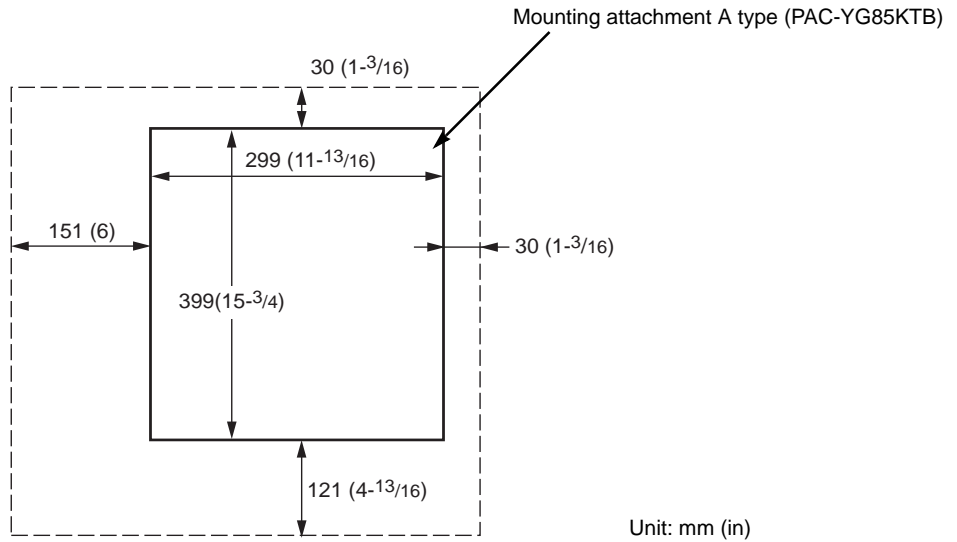

6 | Installation

The cable can be routed either from the top or the bottom.

1. To route the cable from the top

(1) Remove the cover of Mounting attachment A type.

To remove the cover, unscrew the two screws at the bottom of the cover, slide down the cover slightly, and pull it forward.

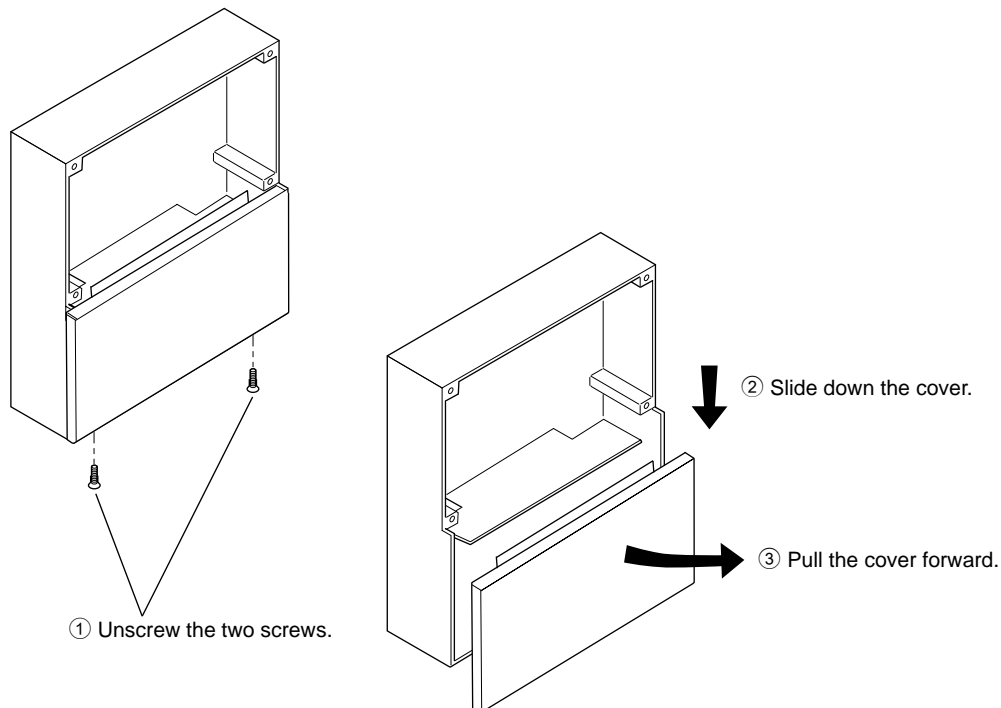

- (2) Cut out the knockout hole on the Mounting attachment A type (PAC-YG85KTB) at the top with a nipper for the cable (the thin part of the plastic).

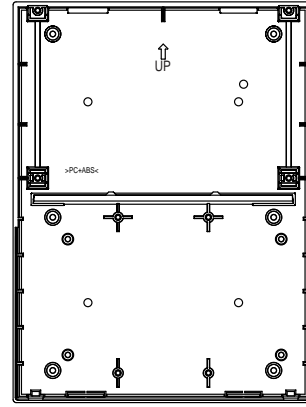
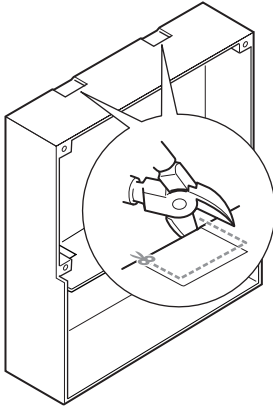

NOTE

Install the Mounting attachment A type (PAC-YG85KTB) so that the arrow (↑UP) on the back of it points up.

- (3) Sand the cut surface of the knockout hole smooth.

CAUTION

Any rough edges that are left may damage the cable and cause electric shock or fire.

- (4) Install the Mounting attachment A type (PAC-YG85KTB) with the six mounting screws (field-supplied).
Use screws that are suitable for the wall type.
Install it on the surface strong enough to support its weight.

NOTE

Install the Mounting attachment A type (PAC-YG85KTB) so that the arrow (↑UP) on the back of it points up.

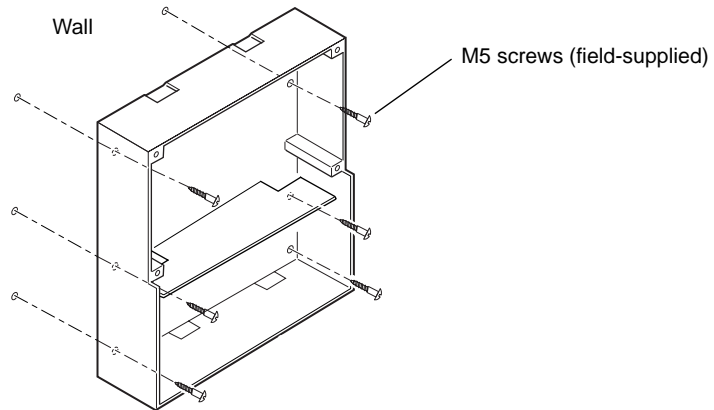

(5) Push the cable through the knockout hole.

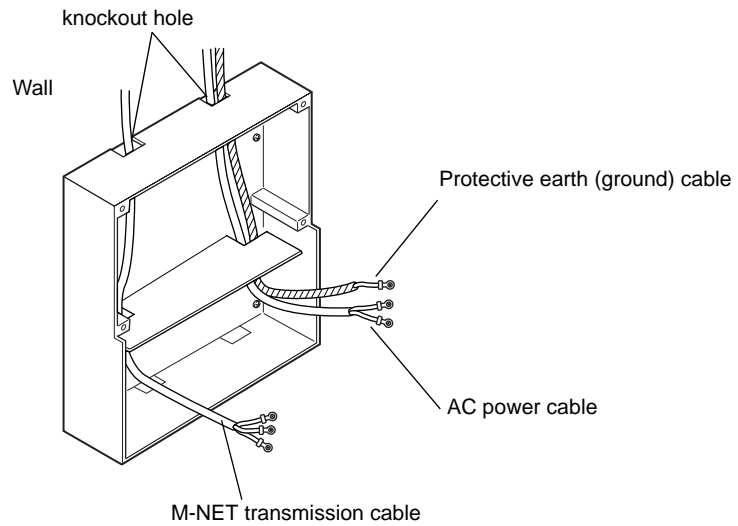

(6) Install the power supply unit (PAC-SC51KUA; sold separately) inside the Mounting attachment A type with the four M4 screws (supplied).

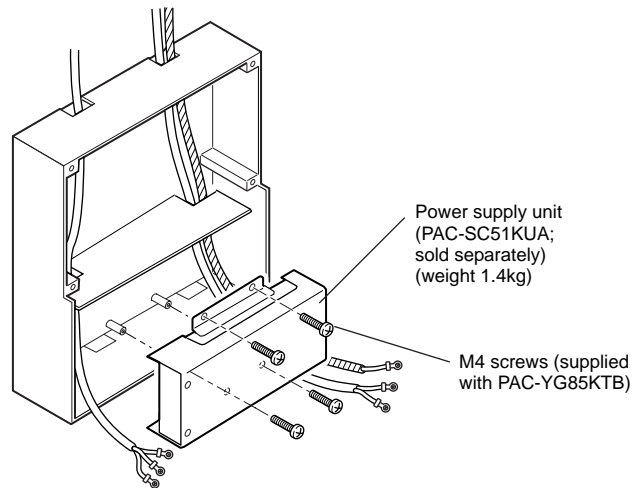

(7) Connect the cables to the power supply unit (PAC-SC51KUA). Refer to the PAC-SC51KUA Installation Manual for details.

(8) Remove AG-150A surface cover.

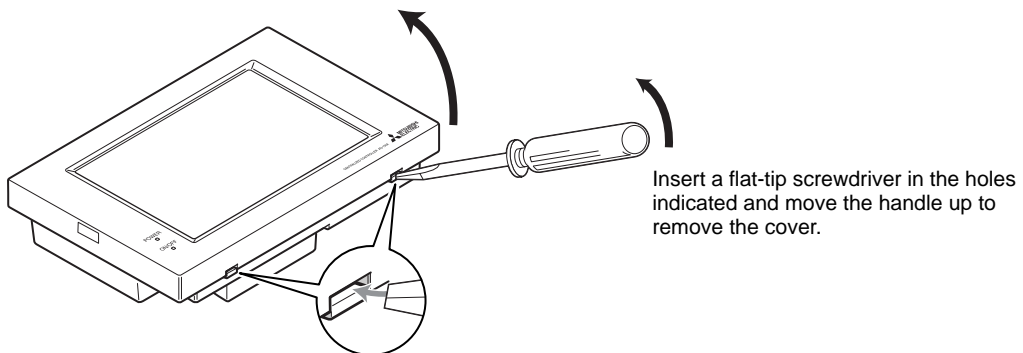

(9) Connect the wiring from the power supply unit to the centralized controller.

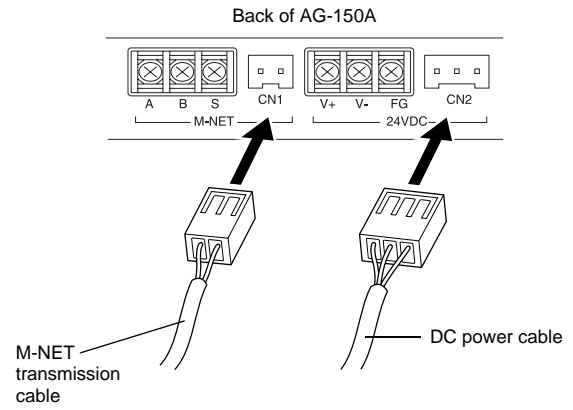
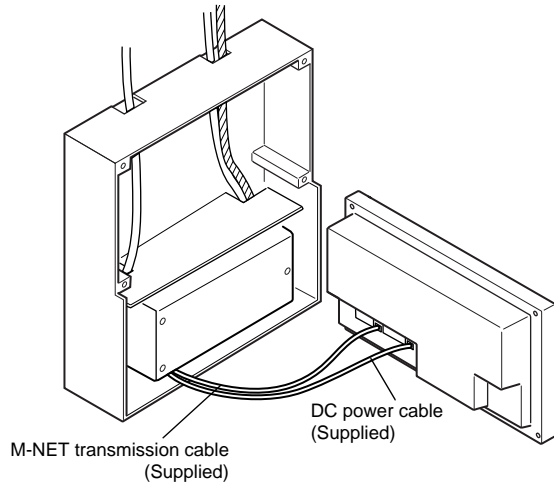

DC power line and M-NET transmission cable are connected using a connector as shown figure below. Connectable to the connector using the cable that is supplied.

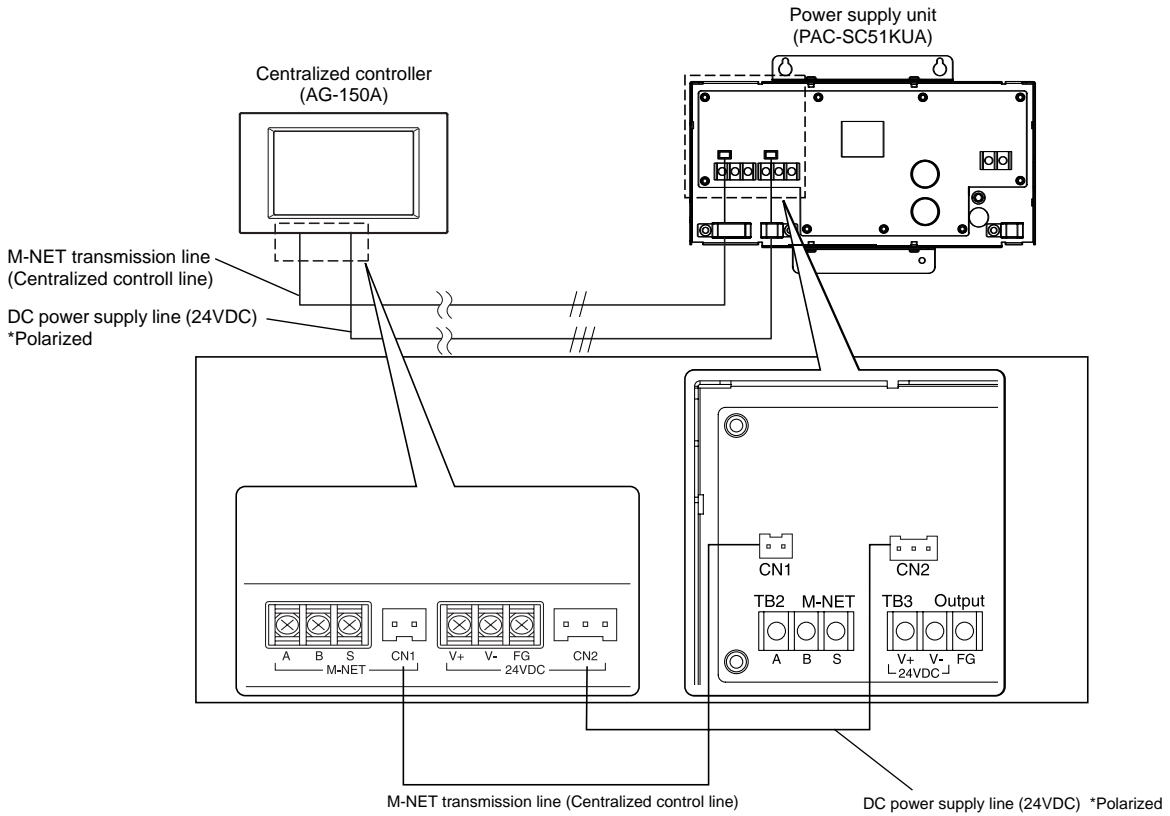

- (10) If the AG-150A is not always connected to the LAN, connect the supplied LAN link-up cable to the LAN connector.
(* If the AG-150A is always connected to the LAN, connect the LAN cable (field supplied) via a HUB and the LAN link-up cable is not required.)

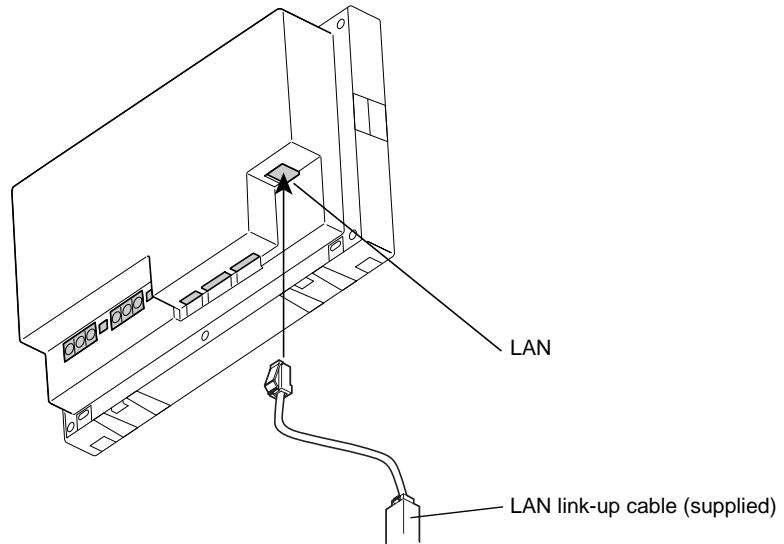

- (11) To use the external I/O, connect the external I/O cable (PAC-YG10HA; sold separately) to CN5 on the AG-150A.

NOTE

- When connecting the external input/output cables to connector CN5 on the controller, punch out the knockout hole.

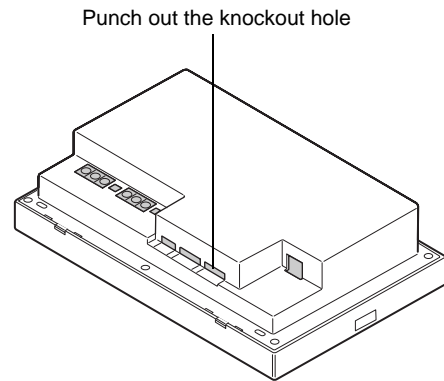

- (12) Securely seal the cable lead-in port with putty to prevent dew, water and insect, etc. from entering.

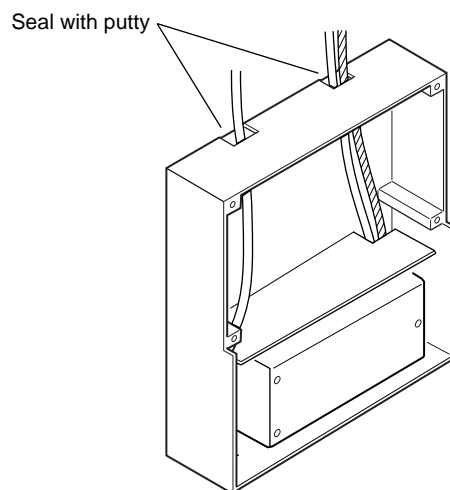

(13) Install the controller inside the Mounting attachment A type with the four M4 rounded screws (supplied).

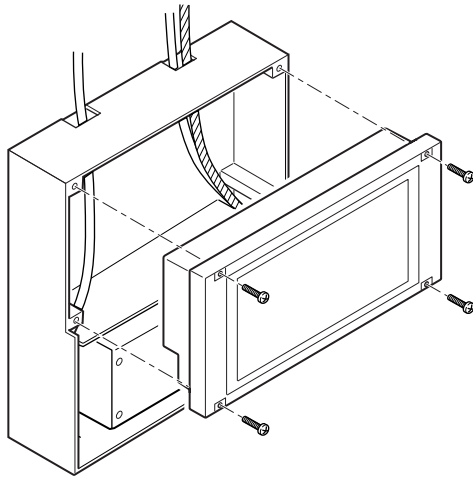

If the LAN link-up cable is used, place it inside the Mounting attachment A type as shown in the figure below.

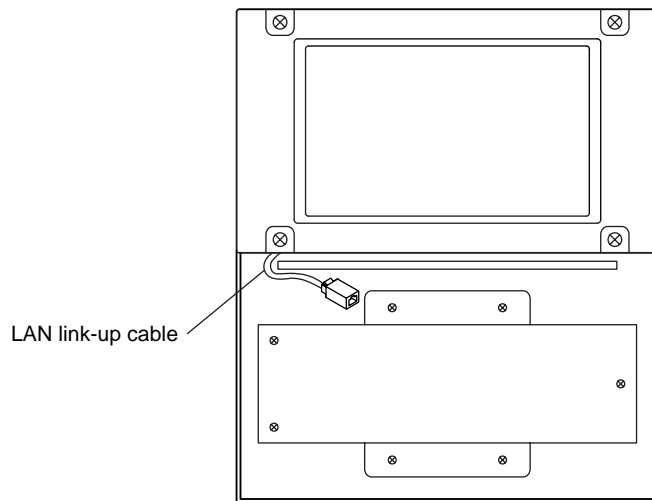

(14) Attach the cover on the AG-150A.

(15) Attach the power supply unit cover with the two screws.

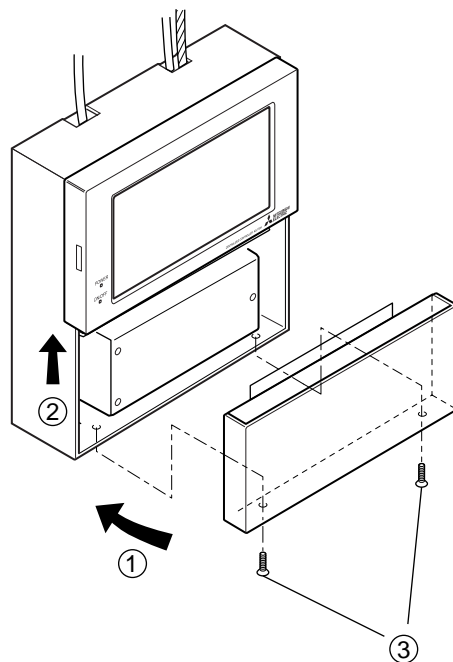

2. To route the cable from the bottom

- (1) Remove the cover of Mounting attachment A type.
(Refer to section 1.(1).)
- (2) Cut out the knockout hole on the Mounting attachment A type (PAC-YG85KTB) at the bottom with a nipper for the cable.

NOTE

Install the Mounting attachment A type (PAC-YG85KTB) so that the arrow (↑UP) on the back of it points up.

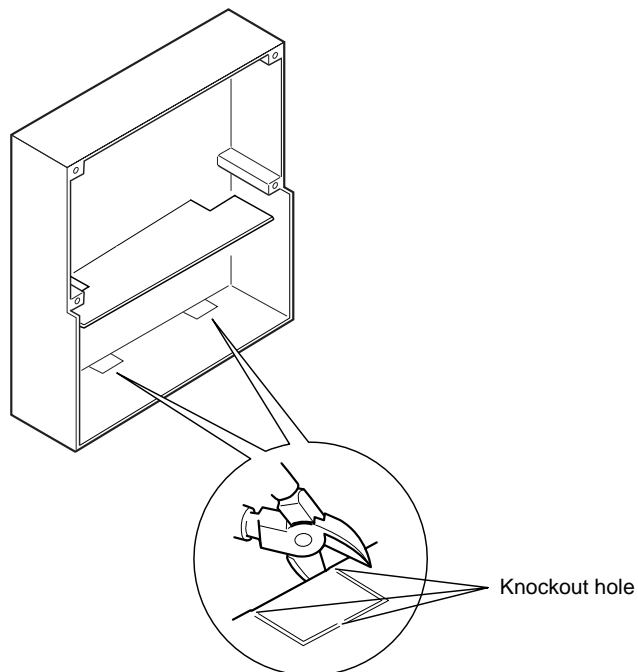

- (3) Sand the cut surface of the knockout hole smooth.

CAUTION

Any rough edges that are left may damage the cable and cause electric shock or fire.

- (4) Install the Mounting attachment A type (PAC-YG85KTB) with the six mounting screws (field-supplied).
Use screws that are suitable for the wall type.
Install it on the surface strong enough to support its weight.
(Refer to section 1.(4).)

NOTE

Install the Mounting attachment A type (PAC-YG85KTB) so that the arrow (↑UP) on the back of it points up.

- (5) Push the cable through the knockout hole.

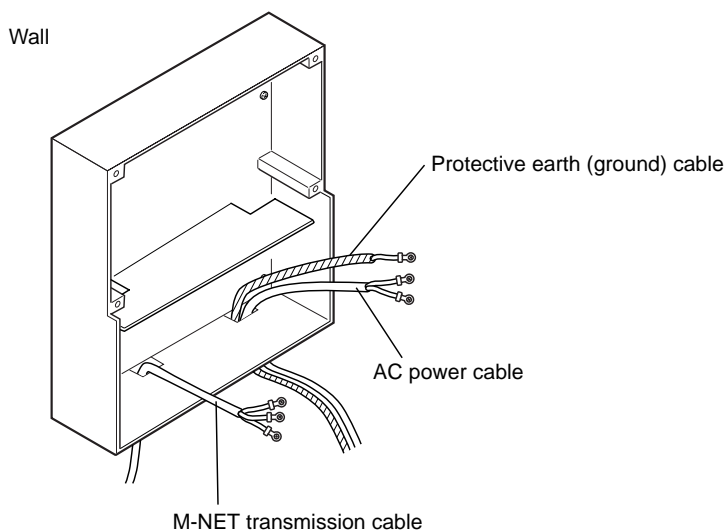

- (6) Install the power supply unit (PAC-SC51KUA; sold separately) inside the Mounting attachment A type with the four M4 screws (supplied).
(Refer to section 1.(6).)
- (7) Connect the cables to the power supply unit (PAC-SC51KUA).
Refer to the PAC-SC51KUA Installation Manual for details.
- (8) Remove the AG-150A surface cover.
- (9) Connect the wiring from the power supply unit to the centralized controller.
(Refer to section 1.(9).)
- (10) If the AG-150A is not always connected to the LAN, connect the supplied LAN link-up cable to the LAN connector.
(* If the AG-150A is always connected to the LAN, connect the LAN cable (field supplied) via a HUB and the LAN link-up cable is not required.)
- (11) To use the external I/O, connect the external I/O cable (PAC-YG10HA; sold separately) to CN5 on the AG-150A.
- (12) Install the centralized controller inside the Mounting attachment A type with the four M4 screws (supplied).
If the LAN link-up cable is used, place it inside the Mounting attachment A type.
(Refer to section 1.(13).)
- (13) Attach the cover on the AG-150A.
- (14) Attach the power supply unit cover with the two screws.
(Refer to section 1.(15).)

7 LAN link-up cable

The LAN link-up cable is used for maintenance purpose when the AG-150A is not always connected to the LAN.

If the AG-150A is not always connected to the LAN, connect a LAN cable to the LAN link-up cable to upgrade the AG-150A software as necessary.

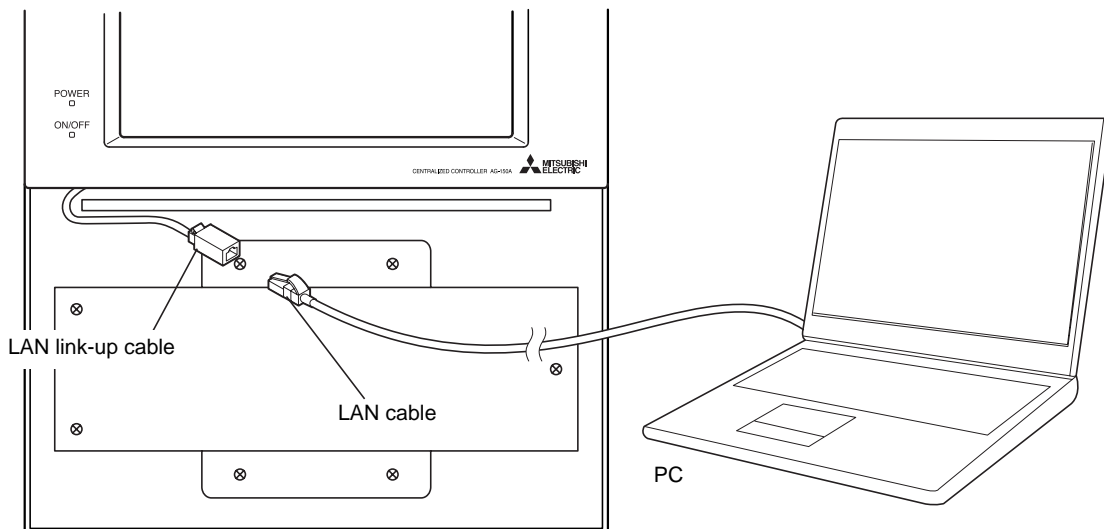

Remove the cover of Mounting attachment A type to use the LAN link-up cable.
Refer to section 1.(1) in (6. Installation) for how to remove the cover.

Please be sure to put the contact address/telephone number on
this manual before handing it to the customer.

 **MITSUBISHI ELECTRIC CORPORATION**

HEAD OFFICE: TOKYO BLDG. , 2-7-3, MARUNOUCHI, CHIYODA-KU, TOKYO 100-8310, JAPAN

Authorized representative in EU: MITSUBISHI ELECTRIC EUROPE B.V.

HARMAN HOUSE, 1 GEORGE STREET, UXBRIDGE, MIDDLESEX UB8 1QQ, U.K.

WT05423X01
Printed in Japan
Recycled Paper