



INSTALLATION - USER - MAINTENANCE MANUAL



EN

Fan coil with casing or for built-in installation, with tangential fan and inverter controlled brushless motor

i-LIFE SLIM 102÷502

U I A	General warnings	3	I A	Water connections	10
U I A	Fundamental safety rules	3	I A	Condensate drain	10
U I A	Product range	4	I A	Filling the system	11
I A	Rated technical specifications	4	I A	Venting air when filling the system	11
I	Overall dimensions	4	I A	Electrical connections	12
I A	Packaging	5	I A	Maintenance	12
I A	Storage on site	5	I A	Cleaning the outside of the unit	12
I A	Installation - Positioning the unit	6	I A	Cleaning the air intake filter	12
I A	Installation procedure	6	I A	Tips on saving energy	14
I A	Minimum installation clearance	6	U A	Troubleshooting	14
I A	Dismantling/assembling the casing	7	U A	Troubleshooting table	14
I A	Vertical installation	7			
I A	Horizontal installation	8			
I A	Fixing the front intake grill	8			
I A	Front grill safety support assembly	9			

The following symbols are used in this publication and inside the unit:



User



Important



Danger high temperatures



Installer



Prohibition



Assistance



Danger voltage

- ⚠ After having removed the packing, check that the contents are intact and complete.
In the event of discrepancies, contact the service centre that sold the appliance.
- ⚠ The appliances must be installed by authorised personnel, who at the end of the work shall issue a declaration of conformity in compliance with the legislation in force and with the instructions provided in the booklet supplied with the appliance.
- ⚠ These appliances have been designed for cooling and heating rooms and must be used in applications compatible with their performance characteristics.
Incorrect installation, adjustment and maintenance or improper use absolve the manufacturer from all liability, whether contractual or otherwise, for damage to people, animals or things.
- ⚠ In the event of water leaks, move the main system switch to the "off" position and close the water taps.
Contact the technical service or a qualified professional as soon as possible. Do not attempt to repair the appliance yourself.
- ⚠ Built-in fan coils are supplied without grills and casing.
Protective covers and air outlet/intake grills must be provided, to prevent accidental contact with the appliance.
- ⚠ The fan coils with casing are equipped with automatically adjustable air outlet louvers. For correct operation of the louvers both when opening and closing, make sure there is nothing that impedes their movement. For troubleshooting information, see the corresponding chapter.
- ⚠ If the appliance is not used for a long period, proceed as follows:
 - Move the main system switch to the "off" position
 - Close the water taps
 - If there is the risk of freezing, empty the system or make sure it antifreeze is added.
- ⚠ Excessively low or high temperatures are harmful to the health and a useless waste of energy.
Avoid extended direct contact with the air flow.
- ⚠ Do not leave the rooms closed for too long.
Periodically open windows to ensure correct air change.
- ⚠ This instruction booklet is an integral part of the appliance and must therefore be kept carefully and must ALWAYS accompany the appliance if sold to another owner or user, or transferred to another system.
If this booklet is lost or damaged, contact your local Technical Service for a replacement.
- ⚠ All repair or maintenance work must be carried out by the company's Technical Service or qualified personnel, following the instructions in this booklet. Do not modify or tamper with the appliance as this may create situations of danger; in such cases the manufacturer of the appliance is not liable for any damage caused.
- ⚠ Pay careful attention to avoiding contact: danger of burns.

FUNDAMENTAL SAFETY RULES

When operating equipment involving the use of electricity and water, a number of fundamental safety rules must be observed, namely:

- ⊖ The appliance is not intended for use by persons (including children) with reduced physical, sensory or mental capabilities, or lack of experience and knowledge, unless they have been given supervision or instruction concerning use of the appliance by a person responsible for their safety.
Children must be supervised to ensure they do not play with the appliance.
Installation must only be performed by qualified personnel.
- ⊖ Do not touch the unit with bare feet or with wet or damp parts of the body.
- ⊖ Never perform any cleaning operations before having disconnected the unit from the mains power supply, moving the main switch to the "off" position.
- ⊖ Do not modify safety or control devices without authorisation and instructions from the manufacturer.
- ⊖ Do not pull, detach or twist the electrical cables coming from the unit, even when disconnected from the mains electricity supply.
- ⊖ Do not introduce objects or substances through the air outlet and intake grills.
- ⊖ Do not open doors or panels providing access to the internal parts of the appliance, without first having moved the main switch to "off".
- ⊖ Do not dispose of, abandon or leave within reach of children packaging materials, as they may represent a hazard.
- ⊖ Do not sit or stand on the appliance and/or rest any type of object on top of it.
- ⊖ The outside components of the appliance may reach temperatures exceeding 70°.

The i-LIFE SLIM range of fan coils comprises 4 versions, DLIU, DLMV, DLMO and DLRV, each of which available in five sizes, with different performance and overall dimensions.

i-LIFE SLIM DLMV

fan coil with painted metal casing (suitable for vertical installation)

i-LIFE SLIM DLMO

fan coil with painted metal casing (suitable for horizontal installation)

i-LIFE SLIM DLIU

built-in fan coil without panelling (suitable for built-in horizontal or vertical installations)

i-LIFE SLIM DLRV

fan coil with painted metal casing with radiant effect (suitable for vertical installation only)

RATED TECHNICAL SPECIFICATIONS

TECHNICAL SPECIFICATIONS		102	202	302	402	502
i-LIFE SLIM						
Coil water content	l	0,47	0,8	1,13	1,46	1,8
Maximum operating pressure	bar	10	10	10	10	10
Maximum water inlet temperature	°C	80	80	80	80	80
Minimum water inlet temperature	°C	4	4	4	4	4
Water connections *	"	Eurokonus 3/4	Eurokonus 3/4	Eurokonus 3/4	Eurokonus 3/4	Eurokonus 3/4
Power supply voltage	V/ph/Hz	230/1/50	230/1/50	230/1/50	230/1/50	230/1/50
Maximum current draw, DLIU, DLMV and DLMO	A	0,15	0,24	0,28	0,29	0,30
Maximum power consumption, DLIU, DLMV and DLMO	W	18	27	35	35	37
Weight, DLIU	kg	9	12	15	18	21
Weight, DLMV and DLMO	kg	17	20	23	26	29
Weight, DLRV	kg	17,3	20,4	23,4	26,4	29,4

* kit supplied as standard containing a pair of adapters for flat gaskets, for 3/4" fittings

OVERALL DIMENSIONS

i-LIFE SLIM DLMV, DLMO, DLRV fan coils with casing		102	202	302	402	502
Dimensions						
A	mm	720	920	1120	1320	1520

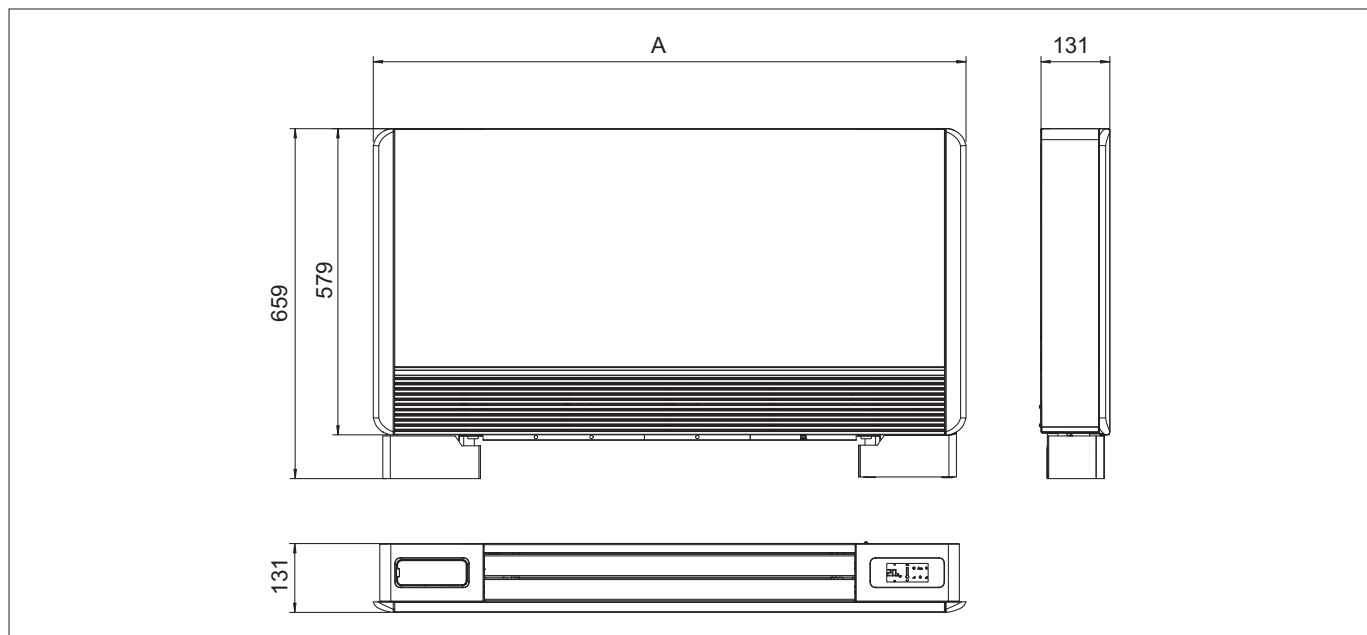

OVERALL DIMENSIONS

I | A

i-LIFE SLIM DLIU built-in fan coil

Dimensions		102	202	302	402	502
A	mm	525	725	925	1125	1325

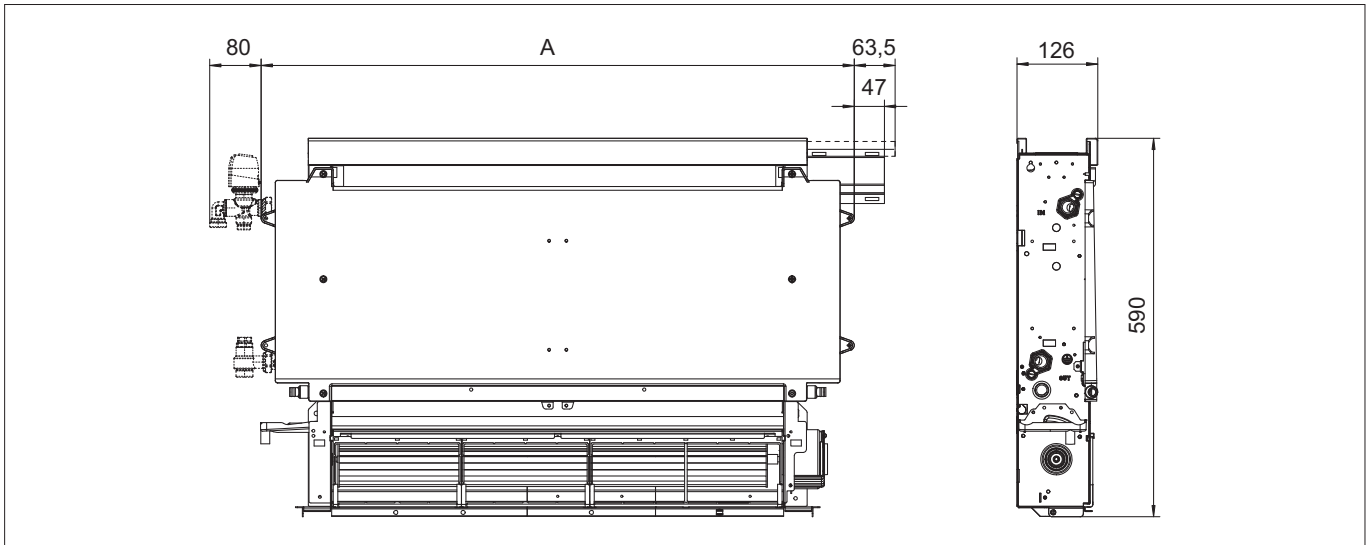

PACKAGING

I | A

The units are delivered in standard packaging comprising a cardboard box on pallets; the accessories are supplied separately, unassembled, or already fitted on the unit (upon request).

Inside the unit is an envelope containing the user, installation and maintenance manual. An identification label is affixed to each individual unit, describing:

- Manufacturer's details
- Model of the unit and part/serial number
- Wiring diagrams

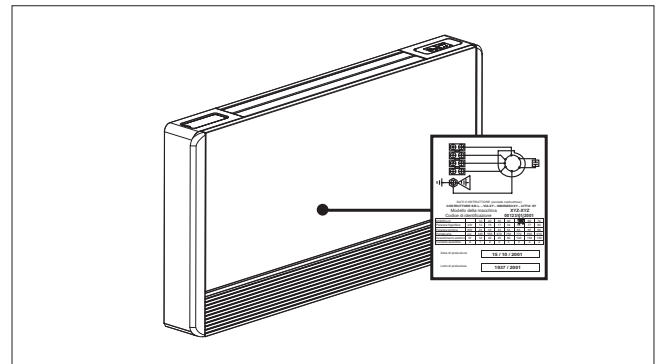
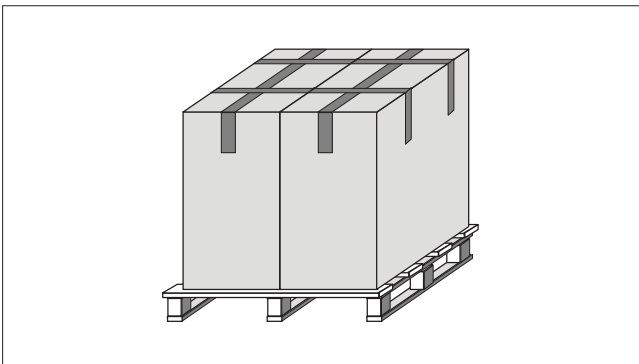

STORAGE ON SITE

I | A

The units must be stored indoors!

⚠ Avoid installing the unit:

- in places exposed to direct sunlight;
- near sources of heat;
- in damp environments and areas where there may be contact with water;
- in environments with oil vapour;
- in environments with high frequency interference.

⚠ Make sure:

- the wall where the unit is installed features a suitable structure and capacity;
- there are no pipes or wiring in the part of the wall affected;

- the wall where the unit is installed is perfectly flat;
- there is sufficient clearance around the unit to allow proper air circulation at the intake and outlet;
- the wall where the unit is installed should be an outside perimeter wall, so as to be able to drain the condensate outside;
- in the event of ceiling installation (DLMO or DLIU version), the air flow must not be aimed directly towards people in the room.

INSTALLATION PROCEDURE

The following descriptions of the various assembly operations and the corresponding drawings refer to versions of the unit with the fittings on the left.

The descriptions of assembly operations for units with the fittings on the right are identical.

Only the drawings will need to be inverted horizontally.

For best installation results and optimum operating performance, carefully observe the instructions provided in this booklet.

Failure to heed the instructions may cause the equipment to malfunction. In such cases, the warranty will be void and the company declines all liability for any damage caused to people, animals or things.

MINIMUM INSTALLATION CLEARANCE

The figure illustrates the minimum clearance to be left from walls and furniture in the room when assembling the fan coil.

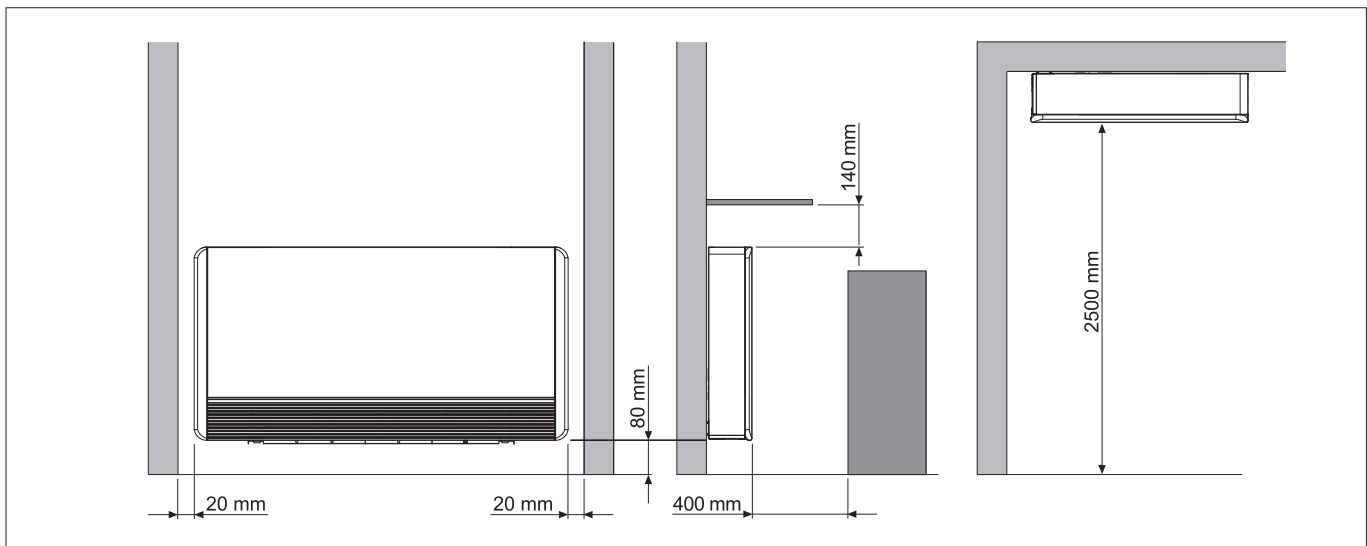

- Remove the front grill.
- Remove the filter, pulling it outwards horizontally
- Unscrew the fastening screws.
- Lift the casing in one piece, as shown in the figure.

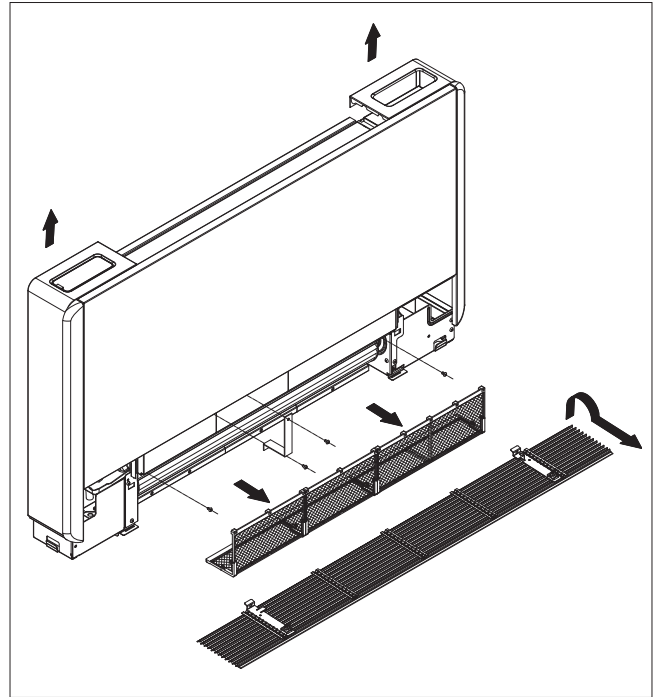

VERTICAL INSTALLATION

For floor-standing assembly using the mouldings, see the individual instruction sheets and the corresponding manual for details on assembling the mouldings.

Use the paper template, and trace the position of the two fastening brackets on the wall.

Drill the holes with a suitable drill bit and insert the anchors (2 for each bracket); fasten the two brackets.

Do not fully tighten the screws, so as to be able to adjust the brackets against a spirit level.

Then secure the two brackets in place by completely tightening the four screws.

Check stability by moving the brackets manually to the right and left, up and down.

Fit the unit, making sure it is correctly attached to the brackets and is stable.

- A anchors
- B brackets

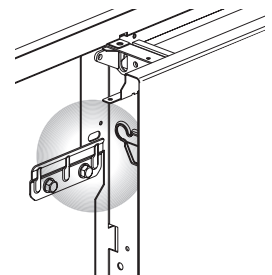
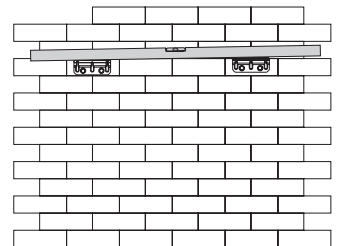
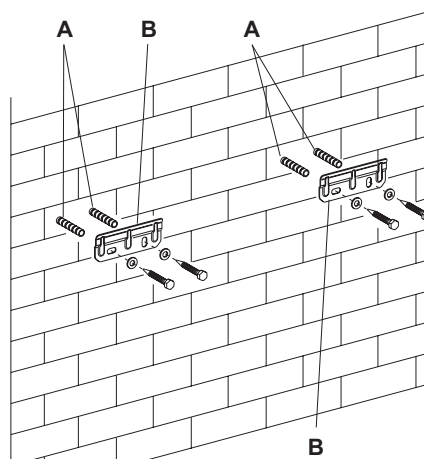
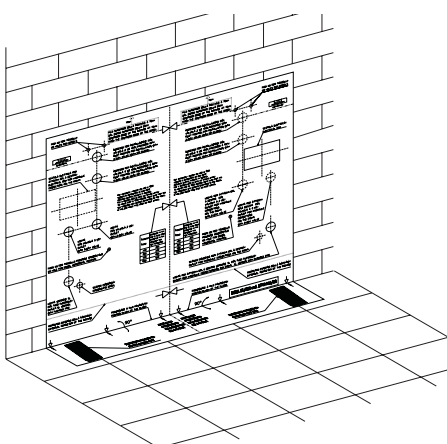

Use the paper template, and trace the position of the two fastening brackets and the two rear screws on the ceiling.
 Drill the holes with a suitable drill bit and insert the anchors (2 for each bracket); fasten the two brackets.
 Do not fully tighten the screws.
 Insert the unit on the two brackets, holding it in position, then tighten the two screws in the rear anchors, one on each side.
 Leave the unit sloping down towards the drain pipe so as to assist drainage.
 Then completely tighten all 6 fastening screws.

For installation of DLMO versions, the horizontal condensate collection pan kits are available as accessories.
 DLRV versions must not be installed horizontally.

⚠ Carefully check the slope of the drain pipe.
 If the drain line is not sloping downwards, water may leak from the line.

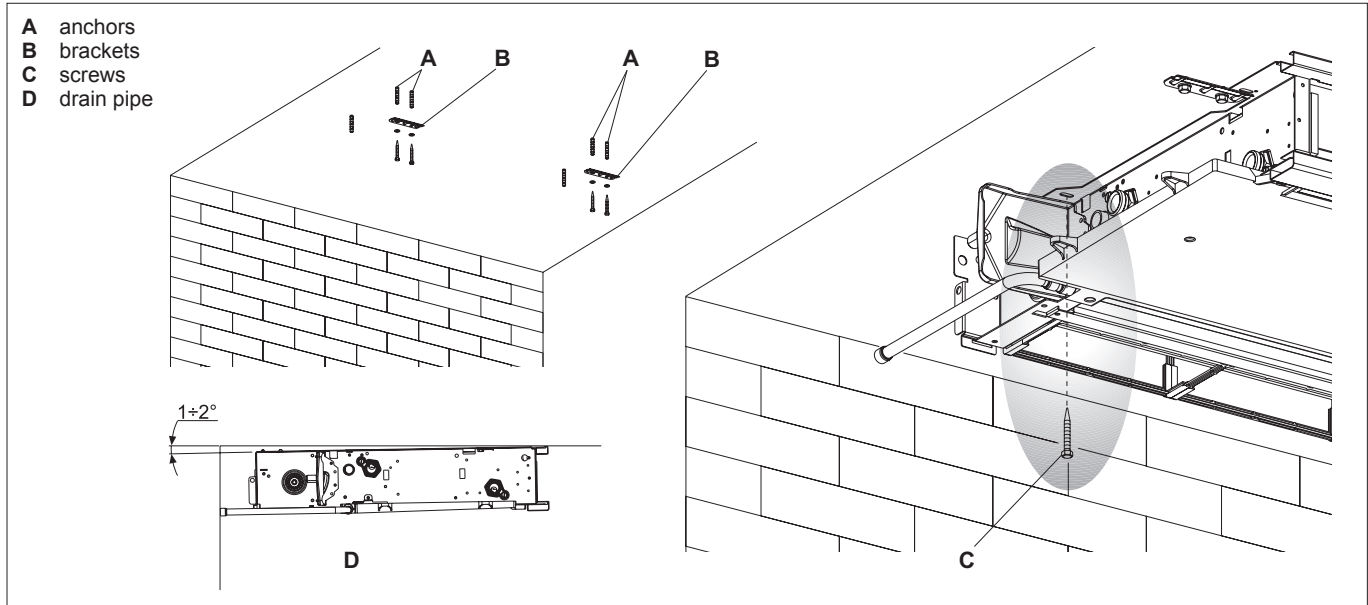

FIXING THE FRONT INTAKE GRILL (MODELS DLMV, DLMO, DLRV)

To prevent the grill from being accidentally removed or left detached from the quick connectors provided and therefore causing the fan coil to malfunction (in this case the fan stops and the grill safety alarm is shown), two screws are supplied that are used to secure the grill in place.
 These are 4.2x9.5 mm socket head screws.

Simply screw these into the holes provided on the grill connection louvers, as shown in the figure.

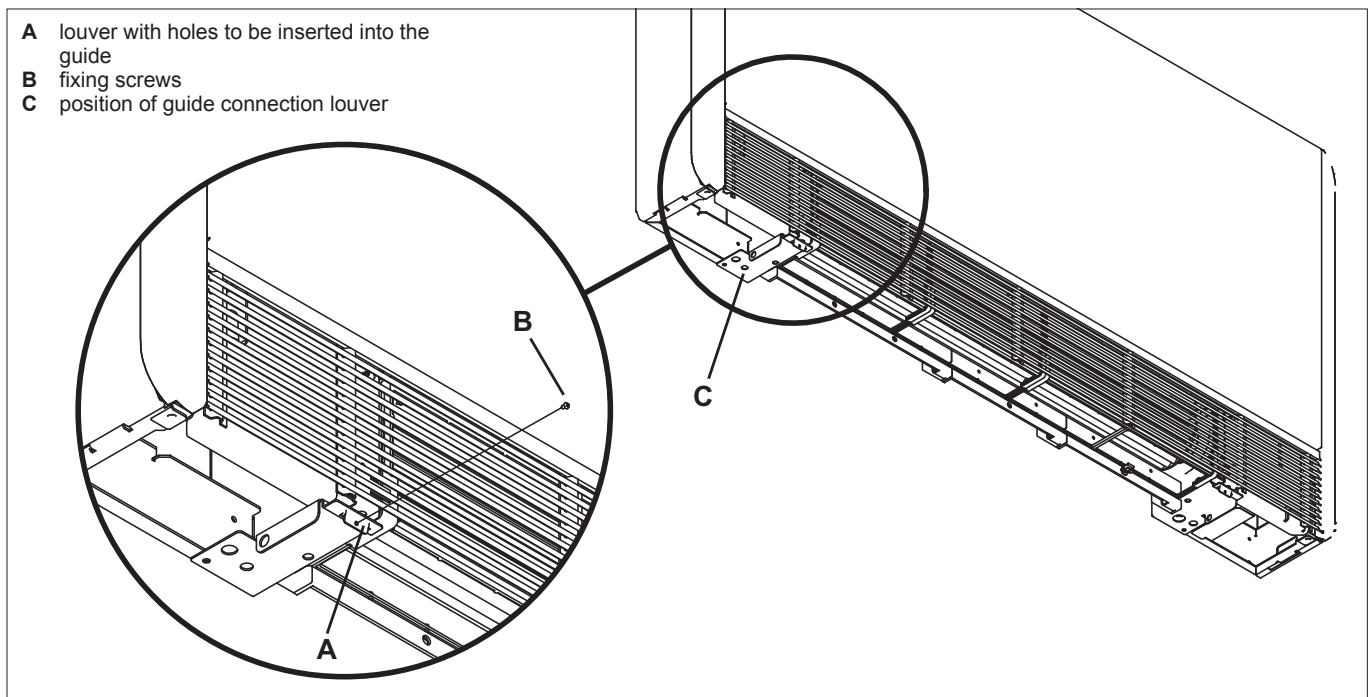

If the fan coil is installed in the horizontal position, to ensure safety when cleaning/replacing the filters, the installer must fit the two safety clamps provided in the bag supplied together with the instruction booklet and the accessories.

- ⚠ These supports are designed to stop the grill from falling.
- Separate the two clamps;
 - open the front grill and completely unscrew the spring fastening screws;
 - fasten the two clamps by tightening the screws again;
 - fasten the other part of the clamps to the grill, using the screws supplied;
 - close the grill.

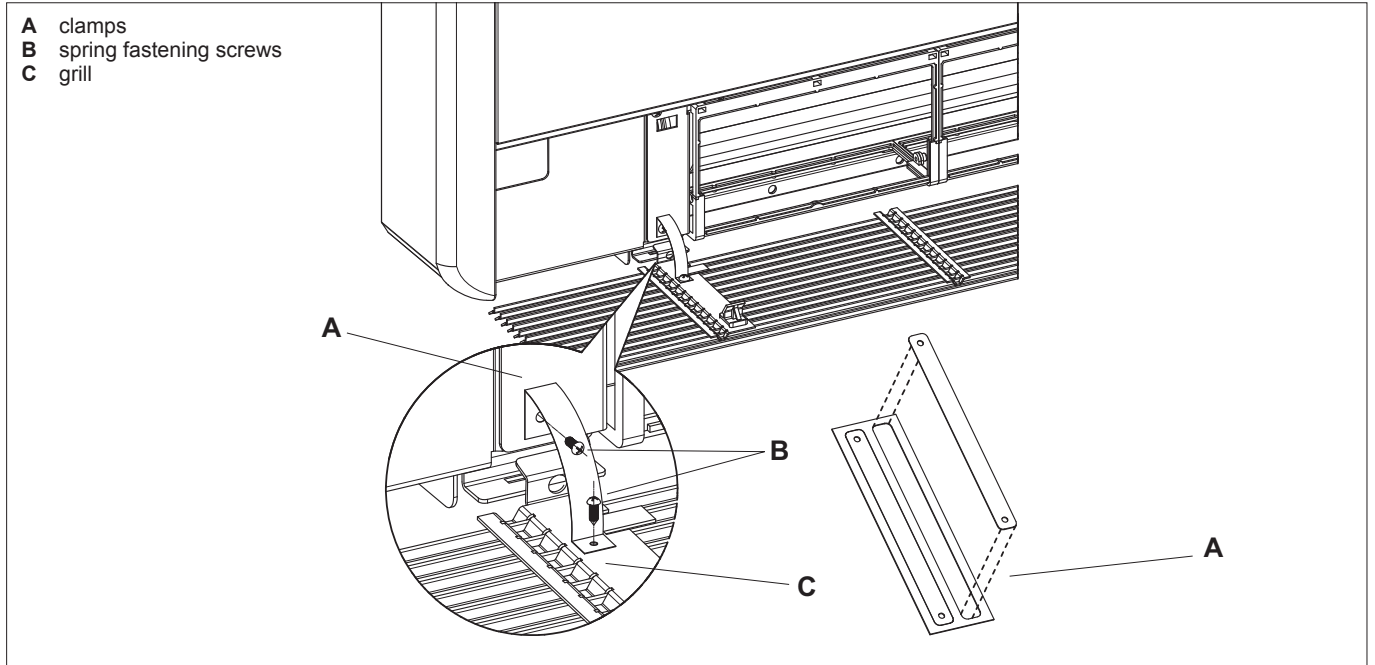

Dimensions		102	202	302	402	502
Pipe diameter	mm	12	14	16	18	20

The choice and sizing of the water lines is the responsibility of the designer, who must apply best working practice and comply with the legislation in force, also considering that undersized lines will lead to poor performance.

To make the connections:

- position the water lines
- tighten the connections using two spanners in opposite directions
- check for any leaks
- cover the connections with insulating material

The water lines and the joints must be thermally insulated.

Make sure the pipes are completely insulated.

Avoid over-tightening so as to not damage the insulation.

To ensure water tightness of threaded connections, use plumber's hemp and green paste; Teflon tape is recommended when antifreeze is added to the water circuit.

CONDENSATE DRAIN

The condensate drain line must be suitably sized (pipe with a minimum inside diameter of 16 mm) and the pipe laid out as to ensure a minimum slope of 1% along the entire line.

For vertical installation, the drain line is connected directly to the drain pan, located at the bottom of the side frame, underneath the water connections.

For horizontal installation, the drain line is connected to the drain pipe already fitted on the unit.

For horizontal installation of DLMO versions, the horizontal condensate collection pan kits are available as accessories.

- If possible, discharge the condensate directly into a gutter or a storm water drain.
- If draining into the sewers, a drain trap should be fitted to prevent bad odours from drifting back into the rooms. The bend in the drain trap must be lower than the condensate collection pan.
- If discharging the condensate into a container, this must be open and the drain pipe must not be immersed in the

water, so as to avoid surface tension and backpressure that would prevent correct drainage.

- If needing to overcome a raised section that would prevent condensate drainage, a pump must be installed:
- for vertical installation, fit the pump underneath the side drain pan;
- for horizontal installation, the position of the pump should be determined according to specific needs.

These pumps are widely available on the market.

In any case, following installation check correct condensate drainage by pouring very slowly (around 1/2 l of water in around 5-10 minutes) into the collection pan.

Assembling the condensate drain pipe on vertical versions

Connect a drain pipe to the condensate collection pan drain fitting and secure it in place.

Make sure that the drip guard is installed correctly.

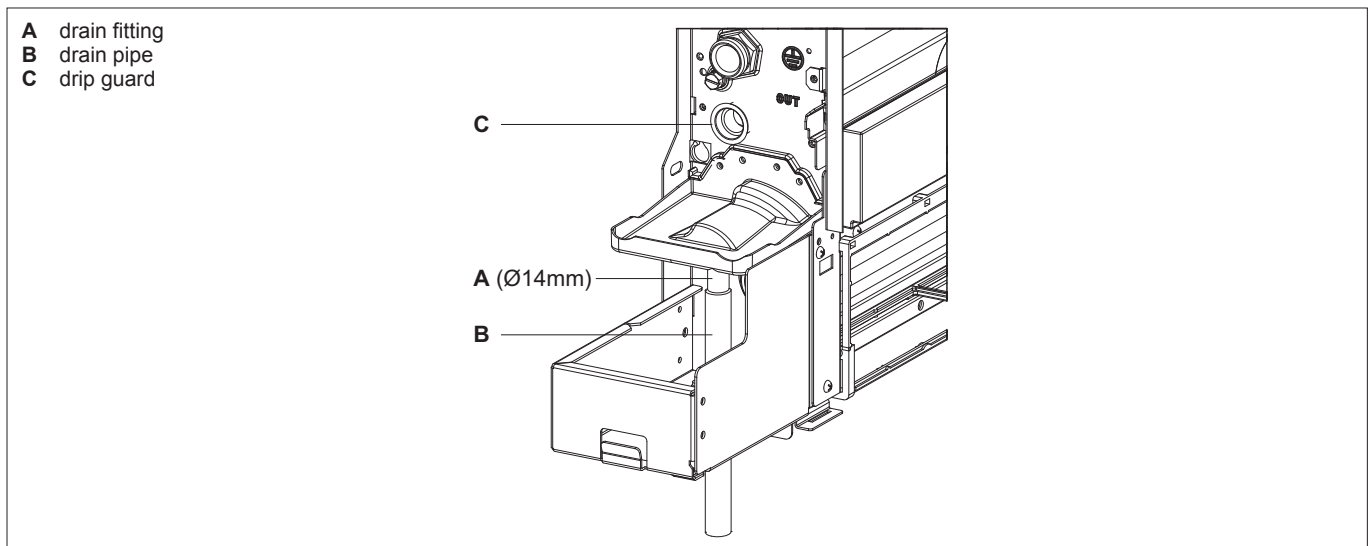

Assembling the condensate drain pipe on horizontal versions

To assemble the horizontal drain pan on DLMO versions, see the instructions supplied with the horizontal pan kit.

- make sure that the "L" pipe and the rubber hose are correctly connected to the pan.
- insert the side of the unit, keeping the pipe held against the front grill.
- close the side, making sure the pipe remains secured in the groove provided on the side.
- If necessary, cut the plastic tube C for the condensate drain and fix the painted pipe to the plastic tube with the supplied clamp so that the knot of the clamp is facing away from the cabinet to keep the pipe to the right slope

for the correct condensate drain. (see **fig. 1**)

N.B. warnings for horizontal installation:

- make sure that the unit is perfectly level, or with a slight slope towards the condensate drain;
- carefully insulate the outlet and return pipes all the way to the unit, so as to prevent condensate from dripping outside of the collection pan;
- insulate the entire condensate pan drain pipe.

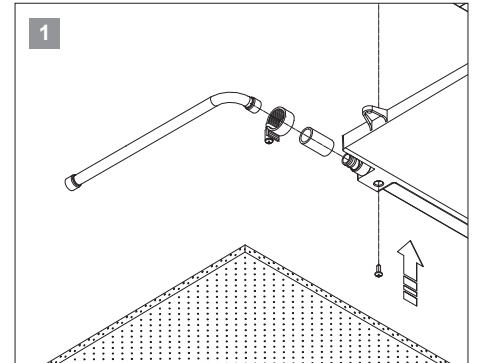
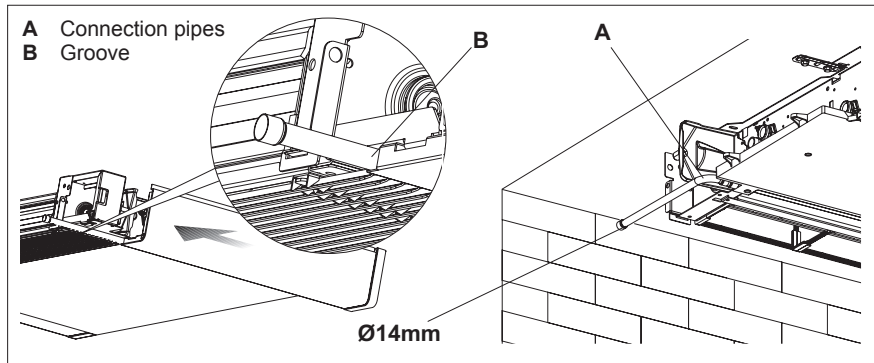

FILLING THE SYSTEM

When starting the system the first time, check that the lock-shield valve is open.

If there is a power failure and the temperature actuated

valve has previously been powered, use the cap provided to press the valve member and open the valve.

VENTING AIR WHEN FILLING THE SYSTEM

- Open all the shut-off devices in the system (manual or automatic);
- Start filling by slowly opening the system water fill tap;
- For models with vertical installation, use a screwdriver to open the vent at the top of the coil; for units with horizontal installation, open the vent at the top; for 4-pipe versions, open the vents at the top of both coils.
- When water starts coming out of the vent valves on the unit, close the vents and continue filling until reaching the rated system pressure.

Check water tightness of the gaskets.

This operation should be repeated after the appliance has been operating a number of hours, and system pressure should be checked periodically.

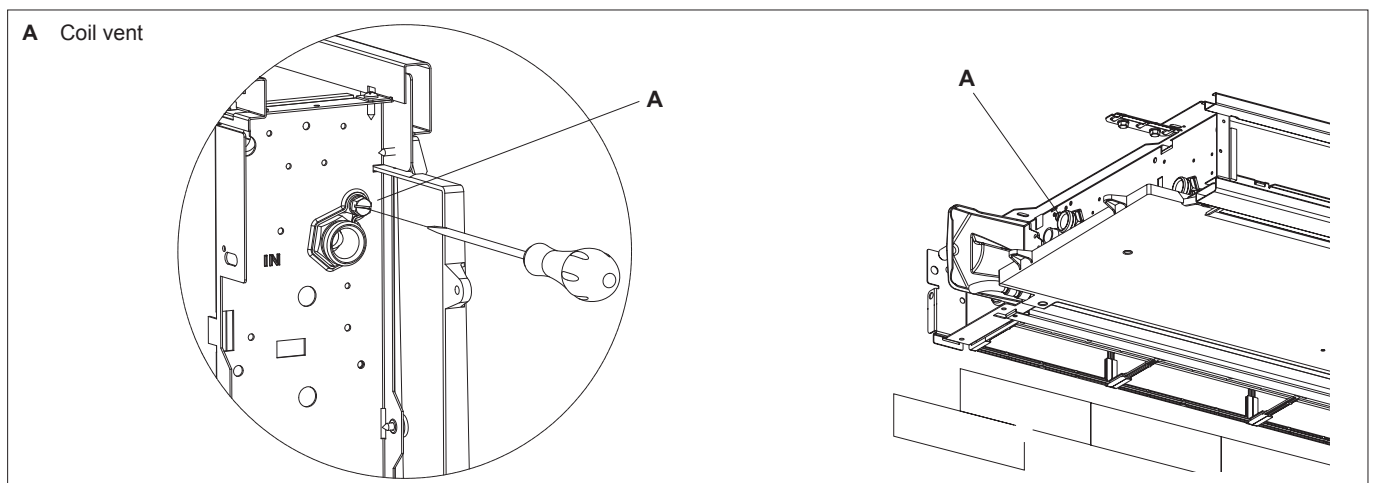

Make the electrical connections following the instructions shown under General warnings and Fundamental safety rules, with reference to the diagrams provided in the accessory installation manuals.

Before performing any work, make sure that power is disconnected.

The appliance must be connected to the power supply via a disconnect switch with minimum contact opening of 3 mm, i.e. a device that ensures complete disconnection of the appliance

MAINTENANCE

Periodical maintenance is essential to ensure efficient, safe and reliable operation of the fan coil over time.

Some maintenance operations are required every six

months, others once a year, carried out by authorised and trained personnel from the Technical Service and using original spare parts when required.

CLEANING THE OUTSIDE OF THE UNIT

⚠ Before any cleaning and maintenance work, disconnect the unit from the mains power supply, switching off the mains switch.

⚠ Wait until the components have cooled down, to avoid the danger of burns.

⚠ Do not use abrasive sponges or abrasive or corrosive detergents, to avoid damaging the painted surfaces.

⚠ When required, clean the outside surfaces of the fan coil using a soft cloth dipped in water.

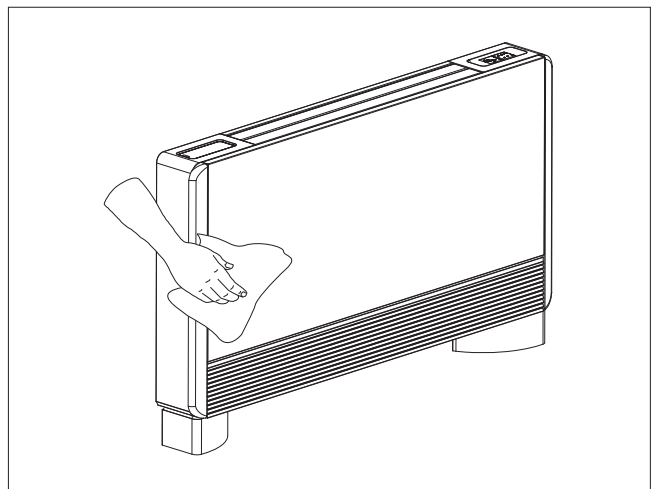

CLEANING THE AIR INTAKE FILTER

After a period of continuous operation, based on the concentration of impurities in the air, or alternatively when

restarting the system after a long period of inactivity, proceed as follows.

Remove the filter cells

- remove the front grill by lifting it slightly and turning it until it is completely released;

- remove the filter, pulling it outwards horizontally.

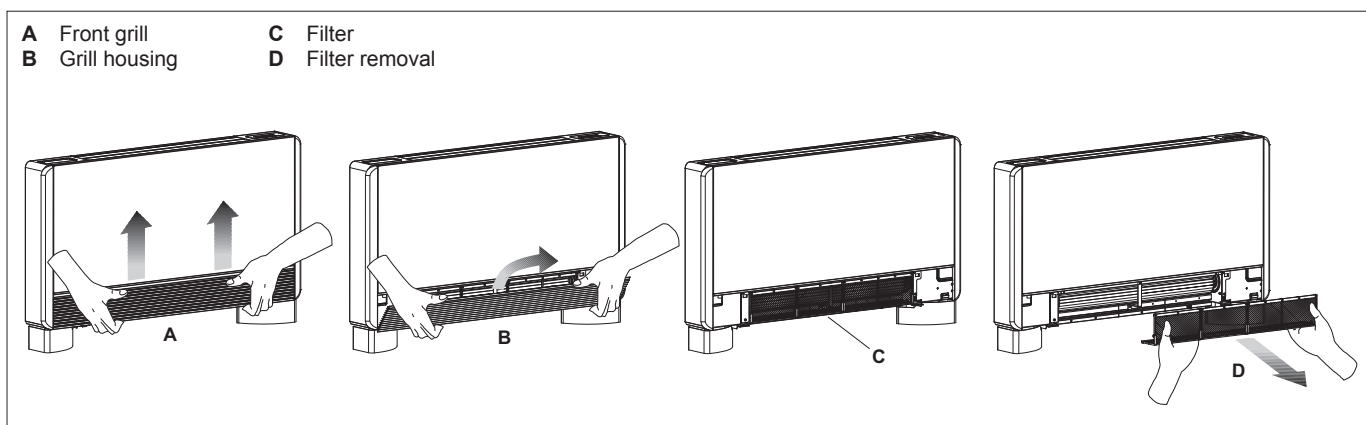

Cleaning the filtering media

- use a vacuum cleaner to remove the dust from the filter with
- wash the filter under running water, without using detergents or solvents, and leave it to dry.
- Reposition the filter on the fan coil, making sure the bottom edge is correctly fitted in place.

⊘ Never use the appliance without the mesh filter.

⚠ The appliance is fitted with a safety switch that prevents the fan from operating if the panel is not fitted or is positioned incorrectly.

⚠ After cleaning the filter, making sure the panel has been positioned correctly.

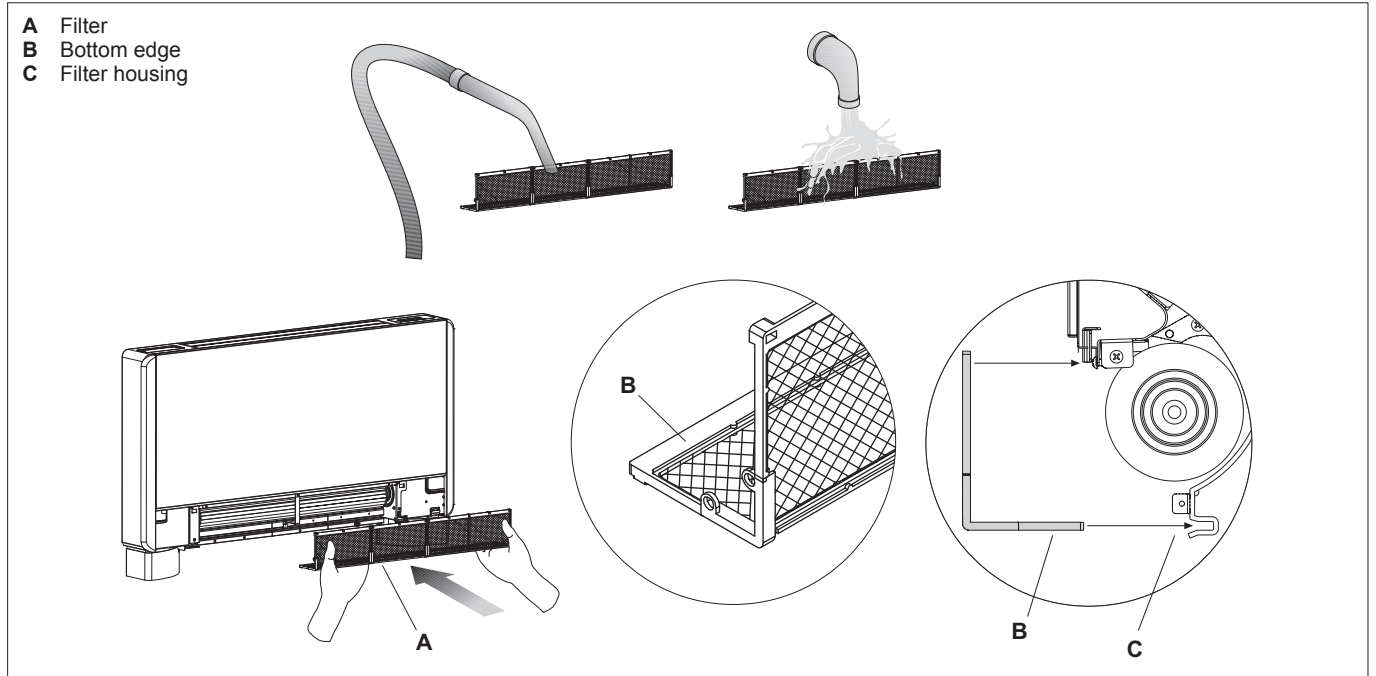

After cleaning

- For versions with louver grills, insert the two tabs into the corresponding slots, turn the grill and press it gently closed at the top.

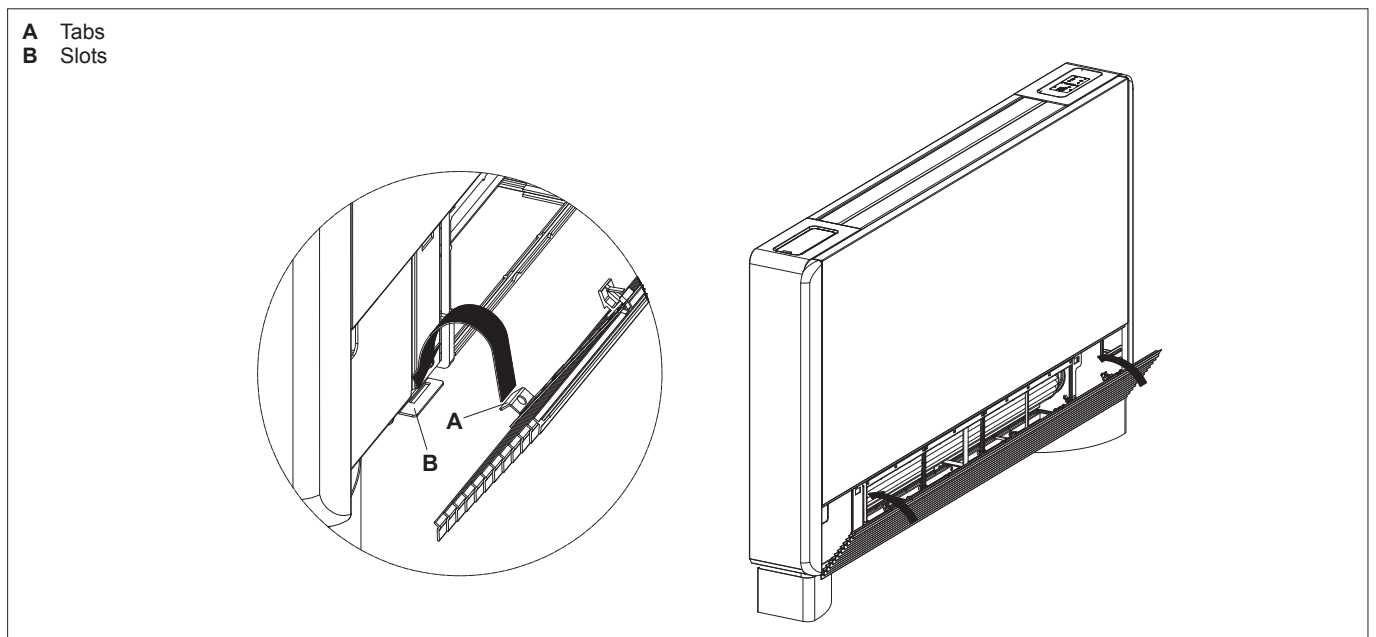

- Keep the filters clean at all times;
- where possible, keep the doors and windows in the air-conditioned room closed;

- where possible, in cooling operation limit exposure of the air-conditioned room to direct sunlight (use curtains, shutters, etc.).

TROUBLESHOOTING

⚠ In the event of water leaks or malfunctions, move the main system switch to the "off" position and close the water taps.

⚠ If one of the following faults occurs, contact the technical service or a qualified professional as soon as possible. Do not attempt to repair the appliance yourself.

- The fan does not start active even when there is hot or cold water in the circuit.
- Water leaks from the appliance in heating mode.
- Water leaks from the appliance in cooling mode only.
- The appliance is very noisy.
- Dew forms on the front panel.

TROUBLESHOOTING TABLE

The following operations must be performed by a qualified installer or a specialist service centre.

Fault	Possible cause	Solution
The fan starts after a delay from changing the temperature settings or function.	The circuit valve takes some time to open and let hot or cold water circulate in the appliance.	Wait 2 or 3 minutes for the circuit valve to open.
The fan does not start.	No hot or cold water in the system.	Make sure that the boiler or water chiller are operating.
The fan does not start active even when there is hot or cold water in the circuit.	The water valve remains closed	Remove the valve body and check if water starts circulating. Check valve operation by powering it separately at 230 V. If the valve is activated, the problem may lie in the electronic controller.
	The fan motor is blocked or burnt out.	Check the motor windings and make sure the fan can spin freely.
	The microswitch that stops the fan when opening the filter grill does not close correctly.	Make sure that when closing the grill, the microswitch contact is activated.
	Incorrect electrical connections.	Check the electrical connections.
Water leaks from the appliance in heating mode.	Leaks from the system water connections.	Check the leaks and fully tighten the connections.
	Leaks from the valves.	Check the gaskets.
Dew forms on the front panel.	Heat insulation detached.	Make sure that the heat insulation/sound-proofing is positioned correctly, especially at the front above the finned coil.
There are droplets of water on the air outlet louvers.	When relative humidity inside the room is quite high (>60%), condensate may form, especially at low fan speed.	When the relative humidity falls, the phenomenon will disappear. In any case, the formation of some droplets of water inside the appliance does not indicate a malfunction.
Water leaks from the appliance in cooling mode only.	The condensate pan is blocked.	Slowly pour a bottle of water into the bottom of the coil to check drainage; if necessary, clean the pan and/or increase the slope of the drain pipe.
	The condensate drain is not sloped downwards enough for correct draining.	
	The connection pipes and valves are not properly insulated.	Check the insulation on the pipes.
The appliance is very noisy.	The fan is touching the structure.	Check the filters and clean them if necessary.
	The fan is unbalanced.	An unbalanced fan will cause excessive vibrations on the unit: replace the fan.
	Check the filters and clean them if necessary	Clean the filters
The louvers stay open.	Possible obstruction blocking rotation.	Remove the obstruction, power off the appliance, wait 2 minutes and power the appliance on again. The louvers close correctly.
	Power failure or disconnection during movement of the louvers.	Restore power to the appliance.



for a greener tomorrow

Eco Changes is the Mitsubishi Electric Group's environmental statement, and expresses the Group's stance on environmental management. Through a wide range of businesses, we are helping contribute to the realization of a sustainable society.



MITSUBISHI ELECTRIC HYDRONICS & IT COOLING SYSTEMS S.p.A.

Head Office: Via Sarson 57/c - 36061 Bassano del Grappa (VI) - Italy

Tel (+39) 0424 509 500 - Fax (+39) 0424 509 509

www.climaveneta.com

www.melcohit.com