

PARTS CATALOG R410A

Outdoor unit [Model Name]	[Service Ref.]
PUHZ-P100VKA	PUHZ-P100VKA.TH PUHZ-P100VKA.TH-ET PUHZ-P100VKA.TH-ER
PUHZ-P125VKA	PUHZ-P125VKA.TH PUHZ-P125VKA.TH-ET PUHZ-P125VKA.TH-ER
PUHZ-P140VKA	PUHZ-P140VKA.TH PUHZ-P140VKA.TH-ET PUHZ-P140VKA.TH-ER
PUHZ-P100YKA	PUHZ-P100YKA.TH PUHZ-P100YKA.TH-ET PUHZ-P100YKA.TH-ER
PUHZ-P125YKA	PUHZ-P125YKA.TH PUHZ-P125YKA.TH-ET PUHZ-P125YKA.TH-ER
PUHZ-P140YKA	PUHZ-P140YKA.TH PUHZ-P140YKA.TH-ET PUHZ-P140YKA.TH-ER

Note:

- RoHS compliant products have <G> mark on the spec name plate.

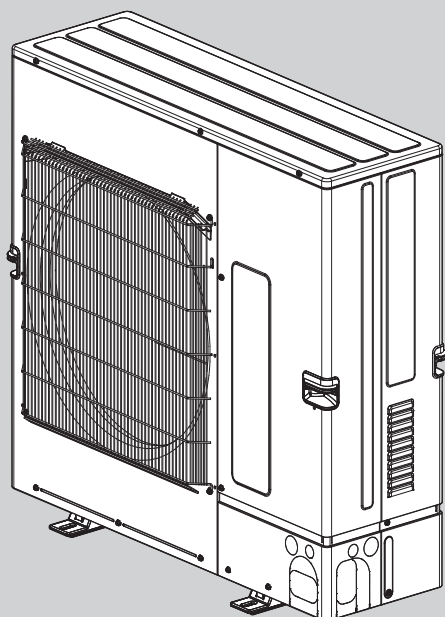

CONTENTS

1. RoHS PARTS LIST	2
--------------------------	---

SERVICE MANUAL (OCH670)

FUNCTIONAL AND ELECTRICAL PARTS

PUHZ-P100VKA.TH
 PUHZ-P100VKA.TH-ET
 PUHZ-P100VKA.TH-ER
 PUHZ-P100YKA.TH
 PUHZ-P100YKA.TH-ET
 PUHZ-P100YKA.TH-ER

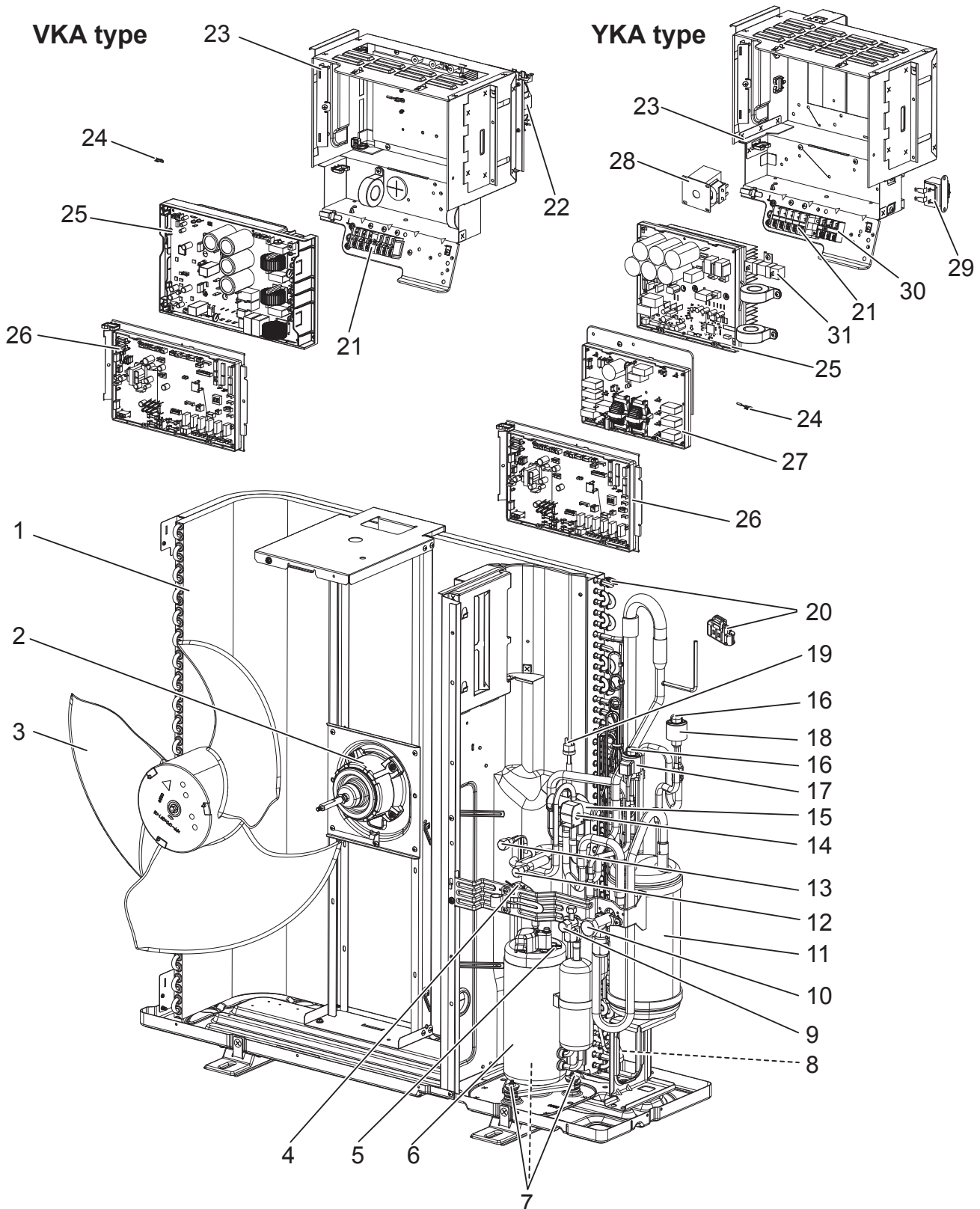

RoHS PARTS LIST

No.	RoHS	Part No.	Part Name	Specification	Q'ty/unit						Remarks (Drawing No.)	Wiring Diagram Symbol
					PUHZ-P100VKA.TH	PUHZ-P100VKA.TH-ET	PUHZ-P100VKA.TH-ER	PUHZ-P100YKA.TH	PUHZ-P100YKA.TH-ET	PUHZ-P100YKA.TH-ER		
1	G	E17 J26 630	OUTDOOR HEAT EXCHANGER		1	1	1	1	1	1		
2	G	E17 F03 301	OUTDOOR FAN MOTOR		1	1	1	1	1	1		MF
3	G	E17 942 501	PROPELLER FAN		1	1	1	1	1	1	1PC/SET	
4	G	E17 E34 307	THERMISTOR (DISCHARGE)		1	1	1	1	1	1		TH4
5	G	E17 E33 307	THERMISTOR (COMP. SURFACE)		1	1	1	1	1	1		TH33
6	G	E17 J26 900	COMPRESSOR SNB220FBGMT		1	1	1				SNB220FBGMT	
	G	E17 J29 900	COMPRESSOR SNB220FBAMT					1	1	1	SNB220FBAMT	
7	G	E12 C34 506	COMPRESSOR RUBBER SET		3	3	3	3	3	3	3PCS/SET	
8	G	E17 944 307	THERMISTOR (OUTDOOR LIQUID PIPE)		1	1	1	1	1	1		TH3
9	G	E17 942 661	STOP VALVE (LIQUID)		1	1	1	1	1	1	3/8	
10	G	E17 E33 661	STOP VALVE (GAS)		1	1	1	1	1	1	5/8	
11	G	E17 J26 959	POWER RECEIVER		1	1	1	1	1	1		
12	G	E17 942 641	CHARGE PLUG		1	1	1	1	1	1		
13	G	E17 943 641	CHARGE PLUG		1	1	1	1	1	1		
14	G	E17 J26 490	R.V. COIL		1	1	1	1	1	1	21S4	
15	G	E12 J61 961	4-WAY VALVE		1	1	1	1	1	1		
16	G	E17 E33 640	LINEAR EXPANSION VALVE		2	2	2	2	2	2		
17	G	E17 J27 493	LINEAR EXPANSION VALVE COIL		1	1	1	1	1	1	LEV-B	
18	G	E17 J26 493	LINEAR EXPANSION VALVE COIL		1	1	1	1	1	1	LEV-A	
19	G	E17 942 646	HIGH PRESSURE SWITCH		1	1	1	1	1	1	4.14 MPA	63HS
20	G	E17 J26 307	THERMISTOR (OUTDOOR 2 PHASE PIPE, AMBIENT)		1	1	1	1	1	1		TH6,7
21	G	E17 E45 374	TERMINAL BLOCK		1	1	1				6P (L,N,G,S1,S2,S3)	TB1
	G	E17 943 374	TERMINAL BLOCK					1	1	1	5P (L1,L2,L3,N,G)	TB1
22	G	E17J26 337	REACTOR		1	1	1					DCL1
23	G	—	ELECTRICAL BOX		1	1	1				BK00N051G35	
	G	—	ELECTRICAL BOX					1	1	1	BK00N051G36	
24	G	E17 E45 307	THERMISTOR (HEAT SINK)		1	1	1					TH8
	G	E17 E35 307	THERMISTOR (HEAT SINK)					1	1	1		TH8
25	G	E17 J26 440	POWER BOARD		1	1	1					P.B.
	G	E17 J27 440	POWER BOARD					1	1	1		P.B.
26	G	E17 J26 450	OUTDOOR CONTROL P.C.BOARD		1	1	1	1	1	1		C.B.
27	G	E17 J27 444	NOISE FILTER P.C.BOARD					1	1	1		NF
28	G	E17 943 337	REACTOR					1	1	1		DCL
29	G	E17 945 337	REACTOR					1	1	1		ACL
30	G	E12 C92 375	TERMINAL BLOCK					1	1	1	3P (S1,S2,S3)	TB2
31	G	E17 E33 360	RESISTOR					1	1	1		RS

RoHS PARTS LIST

FUNCTIONAL AND ELECTRICAL PARTS

PUHZ-P125VKA.TH

PUHZ-P125VKA.TH-ET

PUHZ-P125VKA.TH-ER

PUHZ-P140VKA.TH

PUHZ-P140VKA.TH-ET

PUHZ-P140VKA.TH-ER

PUHZ-P125YKA.TH

PUHZ-P125YKA.TH-ET

PUHZ-P125YKA.TH-ER

PUHZ-P140YKA.TH

PUHZ-P140YKA.TH-ET

PUHZ-P140YKA.TH-ER

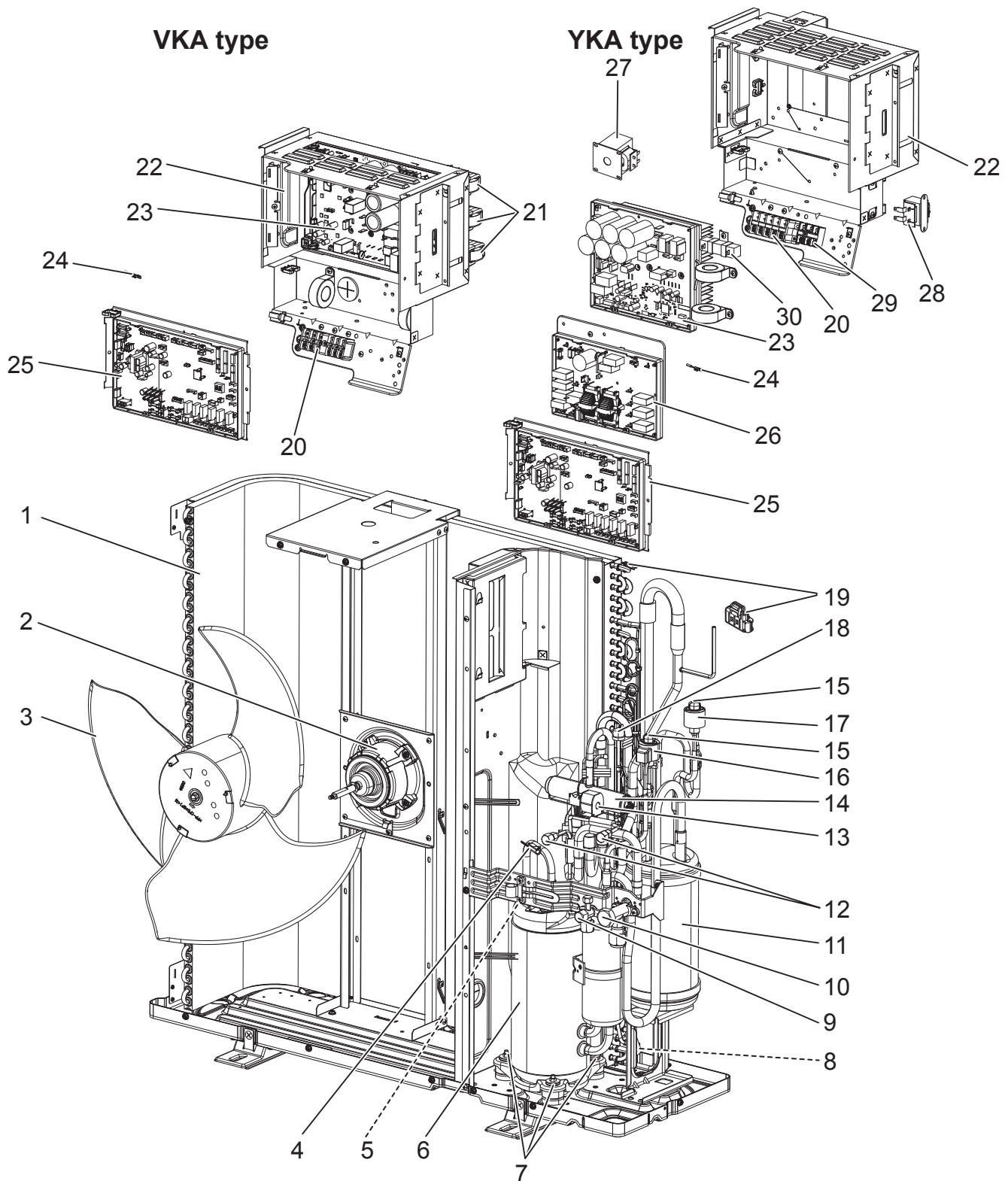

RoHS PARTS LIST

No.	RoHS	Part No.	Part Name	Specification	Q'ty/unit				Remarks (Drawing No.)	Wiring Diagram Symbol
					PUHZ-P125VKA.TH(-ET/-ER)	PUHZ-P140VKA.TH(-ET/-ER)	PUHZ-P125YKA.TH(-ET/-ER)	PUHZ-P140YKA.TH(-ET/-ER)		
1	G	E17 J26 630	OUTDOOR HEAT EXCHANGER		1	1	1	1		
2	G	E17 F03 301	OUTDOOR FAN MOTOR		1	1	1	1		MF
3	G	E17 942 501	PROPELLER FAN		1	1	1	1	1PC/SET	
4	G	E17 E34 307	THERMISTOR (DISCHARGE)		1	1	1	1		TH4
5	G	E17 E33 307	THERMISTOR (COMP. SURFACE)		1	1	1	1		TH33
6	G	E17 E33 900	COMPRESSOR MNB33FBDMC-L		1	1	1	1	MNB33FBDMC-L	
7	G	E12 267 506	COMPRESSOR RUBBER SET		3	3	3	3	3PCS/SET	
8	G	E17 944 307	THERMISTOR (OUTDOOR LIQUID PIPE)		1	1	1	1		TH3
9	G	E17 942 661	STOP VALVE (LIQUID)		1	1	1	1	3/8	
10	G	E17 E33 661	STOP VALVE (GAS)		1	1	1	1	5/8	
11	G	E17 J26 959	POWER RECEIVER		1	1	1	1		
12	G	E17 942 641	CHARGE PLUG		2	2	2	2		
13	G	E17 J26 490	R.V. COIL		1	1	1	1	21S4	
14	G	E17 J27 961	4-WAY VALVE		1	1	1	1		
15	G	E17 E33 640	LINEAR EXPANSION VALVE		2	2	2	2		
16	G	E17 J27 493	LINEAR EXPANSION VALVE COIL		1	1	1	1	LEV-B	
17	G	E17 J26 493	LINEAR EXPANSION VALVE COIL		1	1	1	1	LEV-A	
18	G	E17 942 646	HIGH PRESSURE SWITCH		1	1	1	1	4.14 MPA	63HS
19	G	E17 J26 307	THERMISTOR (OUTDOOR 2 PHASE PIPE, AMBIENT)		1	1	1	1		TH6,7
20	G	E17 E45 374	TERMINAL BLOCK		1	1			6P (L,N,G,S1,S2,S3)	TB1
	G	E17 943 374	TERMINAL BLOCK				1	1	5P (L1,L2,L3,N,G)	TB1
21	G	E17 E45 337	REACTOR SET		3	3			3PCS/SET	DCL1, DCL2, DCL3
22	G	—	ELECTRICAL BOX		1	1			BK00N051G35	
	G	—	ELECTRICAL BOX				1	1	BK00N051G36	
23	G	E17 E45 440	POWER BOARD		1	1				P.B.
	G	E17 E33 440	POWER BOARD				1	1		P.B.
24	G	E17 E45 307	THERMISTOR (HEAT SINK)		1	1				TH8
	G	E17 E35 307	THERMISTOR (HEAT SINK)				1	1		TH8
25	G	E17 J26 450	OUTDOOR CONTROL P.C.BOARD		1	1	1	1		C.B.
26	G	E17 J27 444	NOISE FILTER P.C.BOARD				1	1		NF
27	G	E17 943 337	REACTOR				1	1		DCL
28	G	E17 945 337	REACTOR				1	1		ACL
29	G	E12 C92 375	TERMINAL BLOCK				1	1	3P (S1,S2,S3)	TB2
30	G	E17 E33 360	RESISTOR				1	1		RS

RoHS PARTS LIST

STRUCTURAL PARTS

PUHZ-P100VKA.TH
 PUHZ-P125VKA.TH
 PUHZ-P140VKA.TH
 PUHZ-P100YKA.TH
 PUHZ-P125YKA.TH
 PUHZ-P140YKA.TH

PUHZ-P100VKA.TH-ET
 PUHZ-P125VKA.TH-ET
 PUHZ-P140VKA.TH-ET
 PUHZ-P100YKA.TH-ET
 PUHZ-P125YKA.TH-ET
 PUHZ-P125YKA.TH-ET

PUHZ-P100VKA.TH-ER
 PUHZ-P125VKA.TH-ER
 PUHZ-P140VKA.TH-ER
 PUHZ-P100YKA.TH-ER
 PUHZ-P125YKA.TH-ER
 PUHZ-P125YKA.TH-ER

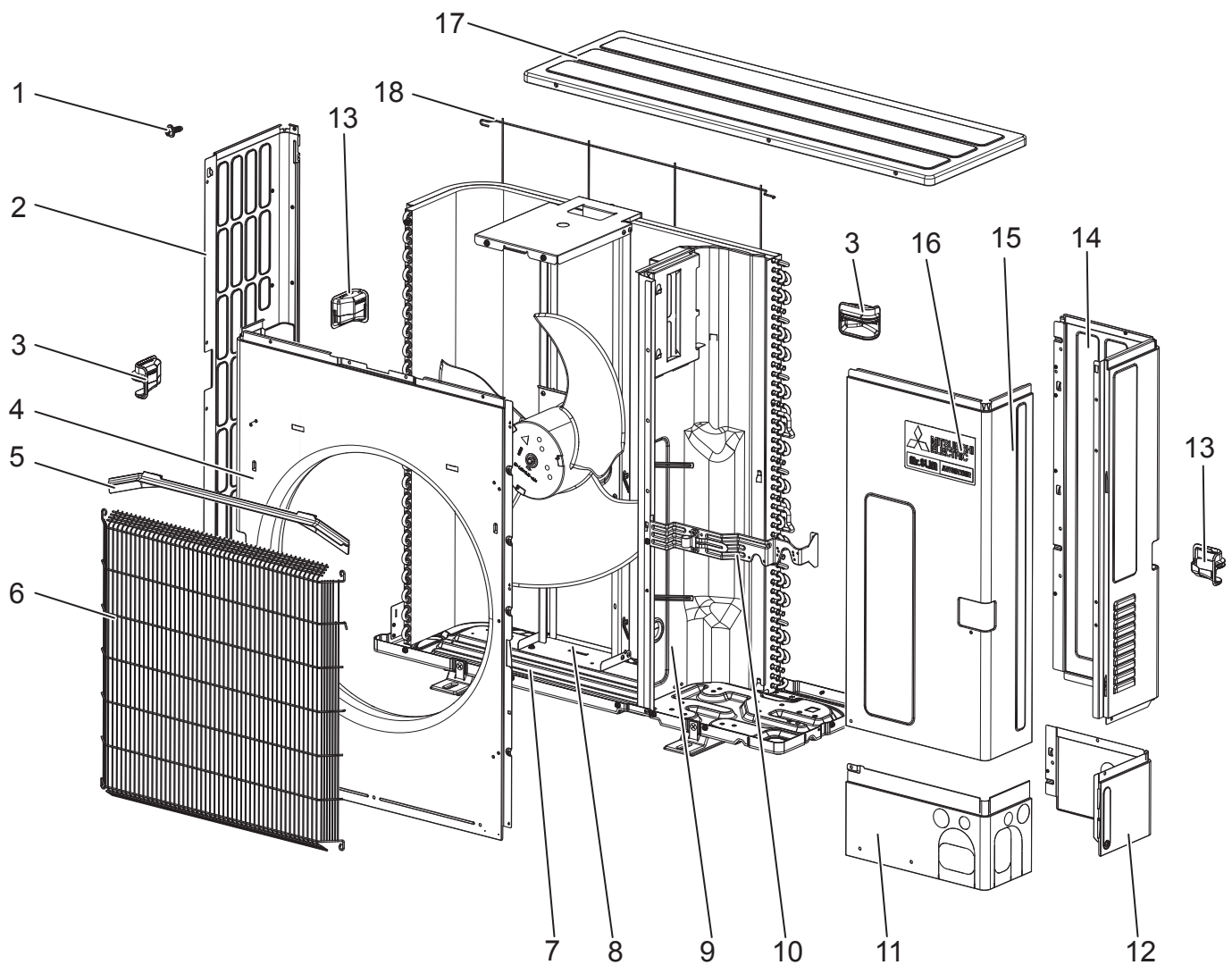

RoHS PARTS LIST

No.	RoHS	Parts No.	Parts Name	Specification	Q'ty/unit						Remarks (Drawing No.)
					PUHZ-P100VKA.TH(-ET/-ER)	PUHZ-P125VKA.TH(-ET/-ER)	PUHZ-P140VKA.TH(-ET/-ER)	PUHZ-P100YKA.TH(-ET/-ER)	PUHZ-P125YKA.TH(-ET/-ER)	PUHZ-P140YKA.TH(-ET/-ER)	
1	G	E17 942 250	F.ST SCREW	(5 × 12)	43	43	43	43	43	43	
2	G	E17 E33 086	SIDE PANEL (L)		1	1	1	1	1	1	
3	G	E17 942 009	HANDLE (FRONT)		2	2	2	2	2	2	1PC/SET
4	G	E17 H93 232	FRONT PANEL		1	1	1	1	1	1	
5	G	E17 A15 531	ICE GUARD		1	1	1	1	1	1	
6	G	E17 H93 521	FAN GRILLE		1	1	1	1	1	1	
7	G	E17 J26 290	BASE ASSY		1			1			
	G	E17 E33 290	BASE ASSY			1	1		1	1	
8	G	E17 J26 515	MOTOR SUPPORT		1	1	1	1	1	1	
9	G	E17 E33 293	SEPARATOR		1	1	1	1	1	1	
10	G	—	STOP VALVE BED		1	1	1	1	1	1	RK00B378G01
11	G	E17 E33 006	COVER PANEL (FRONT)		1	1	1	1	1	1	
12	G	E17 J26 006	COVER PANEL (REAR)		1	1	1	1	1	1	
13	G	E17 943 009	HANDLE (REAR)		2	2	2	2	2	2	
14	G	E17 J26 085	SIDE PANEL (R)		1	1	1	1	1	1	
15	G	E17 J26 245	SERVICE PANEL		1	1	1	1	1	1	
16	G	—	LABEL (MITSUBISHI)		1	1	1	1	1	1	DK79G044H02
17	G	E17 E33 297	TOP PANEL		1	1	1	1	1	1	
18	G	E17 E33 523	REAR GUARD		1	1	1	1	1	1	

Mr. SLIM

mitsubishi electric corporation

HEAD OFFICE : TOKYO BUILDING, 2-7-3, MARUNOUCHI, CHIYODA-KU, TOKYO 100-8310, JAPAN