

Air-Conditioner Control System

Power supply unit

Model: PAC-SC51KUA

Installation Manual

Contents

1. Safety Precautions	1
2. Product features.....	2
1. Specifications	2
2. Power supply capacity.....	2
3. External Dimensions	3
3. Installation	4
1. Parts List	4
2. Field-supplied Parts.....	4
3. Installation area and direction	4
4. Unit installation	5
4. Wiring.....	5
1. Cover Removal and Installation	5
2. Power line.....	6
3. DC Power Supply and M-NET Transmission Line.....	6
5. M-NET Transmission Lines Length.....	10

Before using the controller, please read this Installation Manual carefully to ensure proper operation. Retain this manual for future reference.



This manual details how to install the PAC-SC51KUA power supply unit and its wiring with the centralized controller and the indoor units. For the information about how to install the centralized controller or the indoor units, see the appropriate installation manual. For your safety, first read (1) Safety Precautions described below before installing the PAC-SC51KUA. Store this manual in as easily accessible location. Make sure that this manual will be passed on to any future PAC-SC51KUA power supply unit users.

1 Safety Precautions

Read all the "Safety Precautions" before installing this unit.

Follow at the "Safety Precautions"; the information provides very important points regarding safety.

Symbols and Terms

 WARNING	Statements identify conditions or practices that could result in personal injury or loss of life.
 CAUTION	Statements identify conditions or practices that could result in damage to the unit or other property.

Specific Precautions

 WARNING	
<p>The unit must be installed by a dealer or technical representative. Improper installation by an unqualified person may result in electric shock and fire.</p>	<p>Precisely follow the steps detailed in this manual for proper installation. Any deficiency caused by improper installation may result in an electric shock or fire.</p>
<p>Install in a location that is strong enough to withstand the weight of the unit. A weak installation area may cause the unit to fall down, resulting in a personal injury.</p>	<p>All electrical work must be performed by a licensed technician, according to local regulations and the instructions detailed in this manual. Inadequate electric circuit or any deficiency caused by improper installation may result in an electric shock or fire.</p>
<p>Only use specified cables. Securely connect each cable so that the weight of the cable is not applied to the connectors. Loose or improper connections may result in heat generation or fire.</p>	<p>Ask your dealer or an authorized technician to move or reinstall the controller. Improper installation may result in an electric shock or fire.</p>
<p>Do not attempt to modify or repair the controller. Modification or improper repair may result in electric shock or fire. Consult your dealer when repairs are necessary.</p>	<p>This appliance must be grounded. Make sure to install a protect PE (ground) wire. Do not connect the PE (ground) wire to gas or water pipes, lightning conductors, or telephone lines. Improper grounding may cause an electric shock.</p>
<p>Make sure that the unit is powered by a dedicated line. Other appliances connected to the same line could cause an overload.</p>	<p>Securely install the cover (panel) of the PAC-SC51KUA. If the cover (panel) is not installed properly, dust or water may enter the unit and may result in fire or electric shock.</p>
<p>Make sure that there is a main power switch and Ground-fault interrupter. A ready accessible breaker for power source line helps reduce the risk of electric shock. Installation of a breaker is mandatory in some area.</p>	

 CAUTION	
<p>Do not install the controller where there is a risk of flammable gas. If the leaked gas accumulates around the controller, it may ignite and cause an explosion.</p>	<p>Do not install in a place that has the potential for steam such as bath room or kitchen. Steam may cause an electric shock or unit malfunction.</p>
<p>Do not use the controller in an environment high in oil, steam, or sulfuric gas. These substances may have adverse effects on the performance of the controller or damage its parts.</p>	<p>Do not install in any place where acidic, alkaline solution, special spray, or other substances are used. Doing so may cause an electric shock or unit malfunction.</p>
<p>Install so that the wires are not subjected to any tension. Tension may cause the wires to break, overheating, or fire.</p>	<p>Use standard wires in compliance with the current capacity. A failure to do this may result in an electric leakage, overheating or fire.</p>
<p>Do not wash the unit with water. Doing so may cause an electric shock or malfunction.</p>	<p>Do not touch any PCB (Printed Circuit Board) with your hand or tools. Do not allow dust to collect on the PCB. Doing so may cause fire or an electric shock.</p>
<p>Do not install in any area where the temperature could be more than 55°C (131°F) or less than -10°C (14°F). Do not expose to direct sunlight.</p>	
<p>Use only a breaker and fuse of the specified capacity. If breaker is not installed, it may cause an electric shock. If a fuse and wire or copper wiring that has too large of a capacity is used, it may cause the unit to malfunction or fire.</p>	

2 Product features

This unit supplies DC power to the centralized controller AG-150A via the centralized controller system M-NET transmission line and DC power line. Cannot be used with G-50A.

1. Specifications

Item	Specifications		
Electrical requirements	Rated input voltage and current	100-240VAC ±10%; 0.8A - 0.4A 50Hz/60Hz Single-phase	
	Fuse: 250VAC 6.3A Time-delay type (IEC127-2 S.S.5)		
Output voltage/current	M-NET	23.0 - 32.0VDC	
	DC power supply	24VDC ±5% 0 - 0.75A	
Load capacity (24V)	Number of the loading unit: AG-150A Centralized Controller 1 unit		
Environmental conditions	Temperature	Operating range	-10 to +55°C / +14 to +131°F
		Storage range	-20 to +60°C / -4 to +140°F
	Humidity	30~90%RH (No condensation)	
Dimensions	169 (H) × 271 (W) × 72 (D) mm (6-11/16 [H] × 10-11/16 [W] × 2-7/8 [D] in.)		
Weight	1.4 kg (3-1/8 lbs.)		
Installation Environment	In the metal control panel or in the mounting attachment A type (PAC-YG85KTB) (sold separately) * This unit is designed for a business office or similar environment.		

2. Power supply capacity

2-1. 24V power supply (TB3)

Supplies power to one AG-150A unit.

Not connectable to multiple AG-150A units.

Cannot be used with G-50A.

2-2. M-NET power supply (TB2)

PAC-SC51KUA is capable to supply equivalent power up to 5 (coefficient), therefore the maximum connectable number of system controller is as follows.

Table 1 Equivalent power consumption of controllers

	Centralized controller			Other system controllers		M-NET remote controller
	AG-150A	G-50A	GB-50A	ON/OFF remote controller	System remote controllers (SR) Schedule timers (ST) Group remote controllers (GR)	LOSSNAY remote controller
Coefficient	0.5	_*1	3	1	0.5	0.25

*1. Cannot be used with G-50A. Use PAC-SC50KUA to connect G-50A.

Table 2 Maximum number of connectable controllers when using PAC-SC51KUA

Centralized controller			Other system controllers		M-NET remote controller
AG-150A	G-50A	GB-50A	ON/OFF remote controller	System remote controllers (SR) Schedule timers (ST) Group remote controllers (GR)	LOSSNAY remote controller
1 unit*2	_*1	1 unit*2	5 units	10 units	20 units

*1. Cannot be used with G-50A. Use PAC-SC50KUA to connect G-50A.

*2. Either one AG-150A or one GB-50A can be connected.

Table 3 Connectable number of system controllers when 1 AG-150A is used.

V: Connectable

		Total number of ON/OFF remote controllers (AN)					
		0	1	2	3	4	5
Total number of System remote controllers (SR) Schedule timers (ST) Group remote controllers (GR)	0	V	V	V	V	V	
	1	V	V	V	V	V	
	2	V	V	V	V		
	3	V	V	V	V		
	4	V	V	V			
	5	V	V	V			
	6	V	V				
	7	V	V				
	8	V					
9	V						

3. External Dimensions

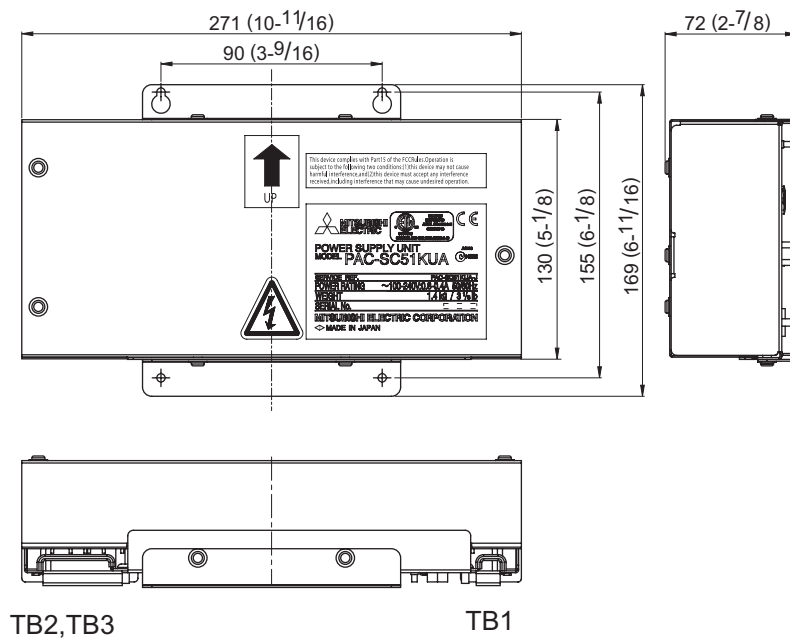

Unit: mm (in.)

3 Installation

1. Parts List

The parts listed below are included with the unit.

- ① PAC-SC51KUA 1 unit
- ② L-shaped mounting brackets 1 set
- ③ M4 screw (4 pieces for attaching the PAC-SC51KUA and the mounting bracket)
- ④ Installation Manual

2. Field-supplied Parts

Obtain the parts listed below before installing the unit.

Field-supplied Parts	Specification
Attachment screw	M4 screw × 4 pieces For wall mounting the unit.
Power cable/ Ground cable	Use sheathed vinyl cord or wire. Wire type: Wire should not be lighter than standard PVC sheathed flexible cord IEC 60227 (designation 60227 IEC 53) Wire size: 0.75mm ² to 2mm ² (AWG18 to 14)
Main power switch* ¹ Breaker for wiring	<ul style="list-style-type: none"> • Local switch: Capacity 3A, Fuse 3A* * Use B type fuse. • Molded case breaker for wiring (NFB): Capacity 3A
Ground-fault interrupter	Level of earth leakage: 30mA, 0.1 sec or less
Transmission cable	Type: Sheathed vinyl cords or cable that complies with the following specifications or equivalent. <ul style="list-style-type: none"> • CPEVS: φ1.2mm to φ1.6mm • CVVS: 1.25mm² to 2mm² (AWG16 to 14) * CPEVS: PE insulated, PVC jacketed shielded communication cable * CVVS: PVC insulated, PVC jacketed shielded control cable PE: Polyethylene PVC: Polyvinyl chloride Cable length: Please refer to section (5) M-NET Transmission Lines Length
DC power cable	DC power cable should comply with both local standards as well as the power requirements of the unit. Recommended type: 0.75mm ² to 2mm ² (AWG18 to 14) Cable length: Within 50m (164 ft)

*1 When installing the unit, use the switch having a contact separation of at least 3mm (1/8 in) in each pole.

3. Installation area and direction

(1) To install the unit inside the metal control panel

Attach the mounting brackets to PAC-SC51KUA as shown in Fig. 3-1.

PAC-SC51KUA Power supply unit is not waterproof.

PAC-SC51KUA shall be installed in a metal control panel box (steel: thickness 1mm (1/16 in.) or more).

Follow the installation requirements as shown in Fig. 3-1.

(Install in an area capable of withstanding a 1.4 kg (3-1/8 lbs.) load.)

Only install the unit vertically as indicated by the arrow on the cover shown in Fig. 3-1.

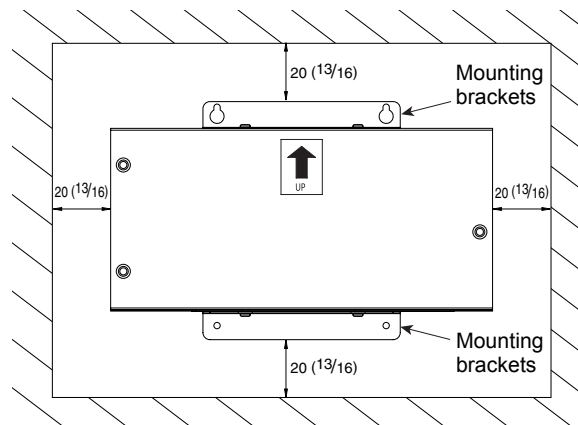

Fig. 3-1

Unit: mm (in.)

(2) To install the unit inside the mounting attachment A type (PAC-YG85KTB) (sold separately).

PAC-SC51KUA can be installed inside the mounting attachment A type (PAC-YG85KTB) (sold separately).

Refer to the AG-150A Installation Manual for details.

4. Unit installation

Attach the unit to the metal control panel box using M4 screws as shown in Fig. 3-2.

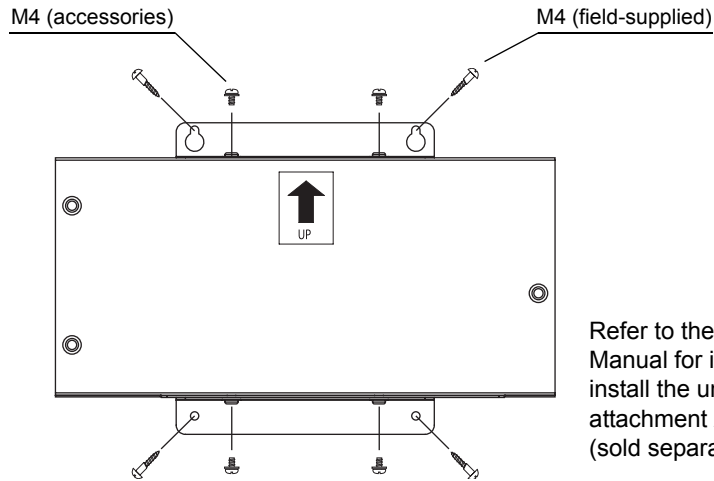

Refer to the AG-150A Installation Manual for instructions on how to install the unit inside the mounting attachment A type (PAC-YG85KTB) (sold separately).

Fig. 3-2

⚠ CAUTION

The unit should be attached on all four corners to prevent it falling down.

4 | Wiring

⚠ WARNING

- All electric work must be performed according to local regulations. Improper electrical work may result in electric shock or fire.
- Be sure to shut off the power source of this unit and all other connected units before wiring.

⚠ CAUTION

Do not connect the AC power line to the M-NET and POWER (24VDC) terminal blocks of this device; otherwise, the unit may fail.

1. Cover Removal and Installation

Remove the three mounting screws and the cover.

Attach the corner to the unit by tightening the three screws indicated in Figure 4-1.

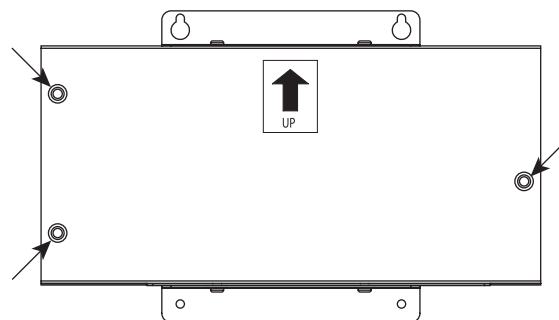
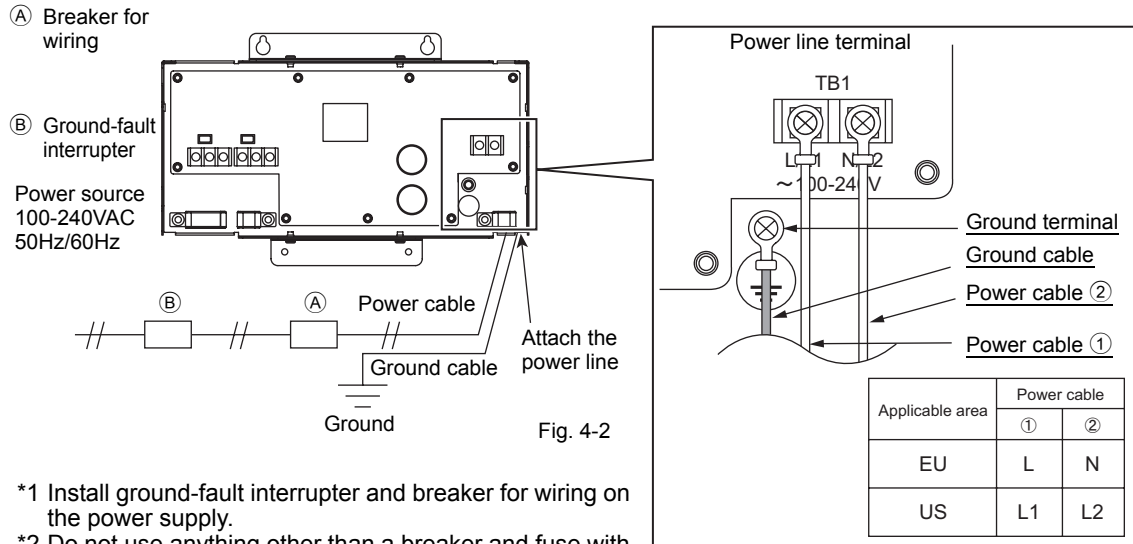

Fig. 4-1

2. Power line

Wire the power and ground cables to L/L1, N/L2 and the ground cable terminals on TB1 as shown in Fig. 4-2.



- *1 Install ground-fault interrupter and breaker for wiring on the power supply.
- *2 Do not use anything other than a breaker and fuse with the correct capacity. Using a fuse or wire of too large capacity may cause malfunction or fire.
- *3 Note : When installing the unit, use the switch having a contact separation of at least 3mm (1/8 in.) in each pole.

- * Use L/N in EU.
- * Use L1/L2 in the U.S.
- * Use a ring terminal to connect to the terminal block.

3. DC Power Supply and M-NET Transmission Line

3-1. When connecting to the centralized controller (AG-150A)

(1) Without the use of an expansion controller (PAC-YG50ECA)

(a) Connected via the terminal block

The DC power cable and M-NET transmission line connect as shown in Fig. 4-3. The DC power cable has a 24VDC and a GND polarity. Connect it to the terminals in accordance with the polarity. Connect the M-NET transmission line to the A, B (non-polarity), and S (shield) terminal block.

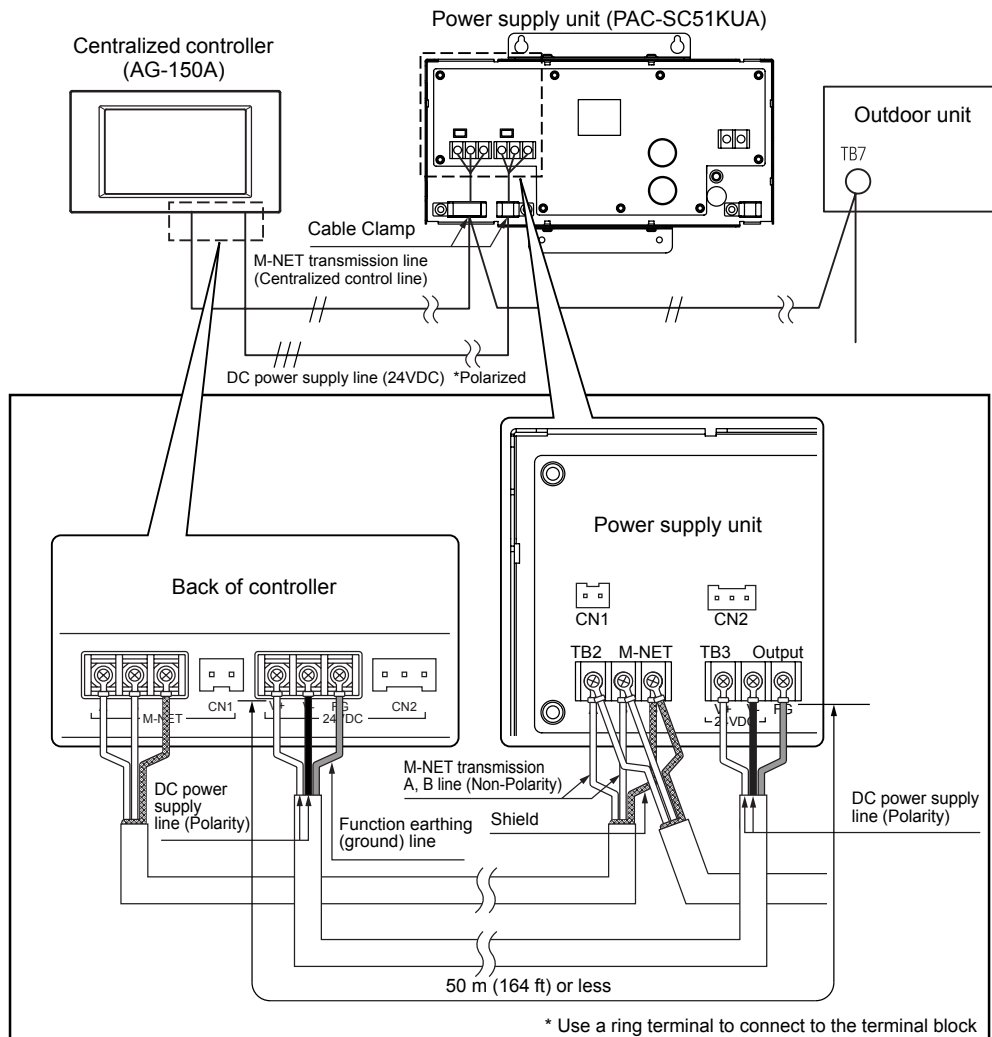

Fig. 4-3

(b) Connecting the connector

When installing the unit in the mounting attachment A type (PAC-YG85KTB) (sold separately), DC power cable and M-NET transmission line can be connected with the connector as shown in the Fig. 4-4. Connectable to the connector using the cable that is supplied with AG-150A (Refer to the Installation Manual that came with AG-150A for details.)

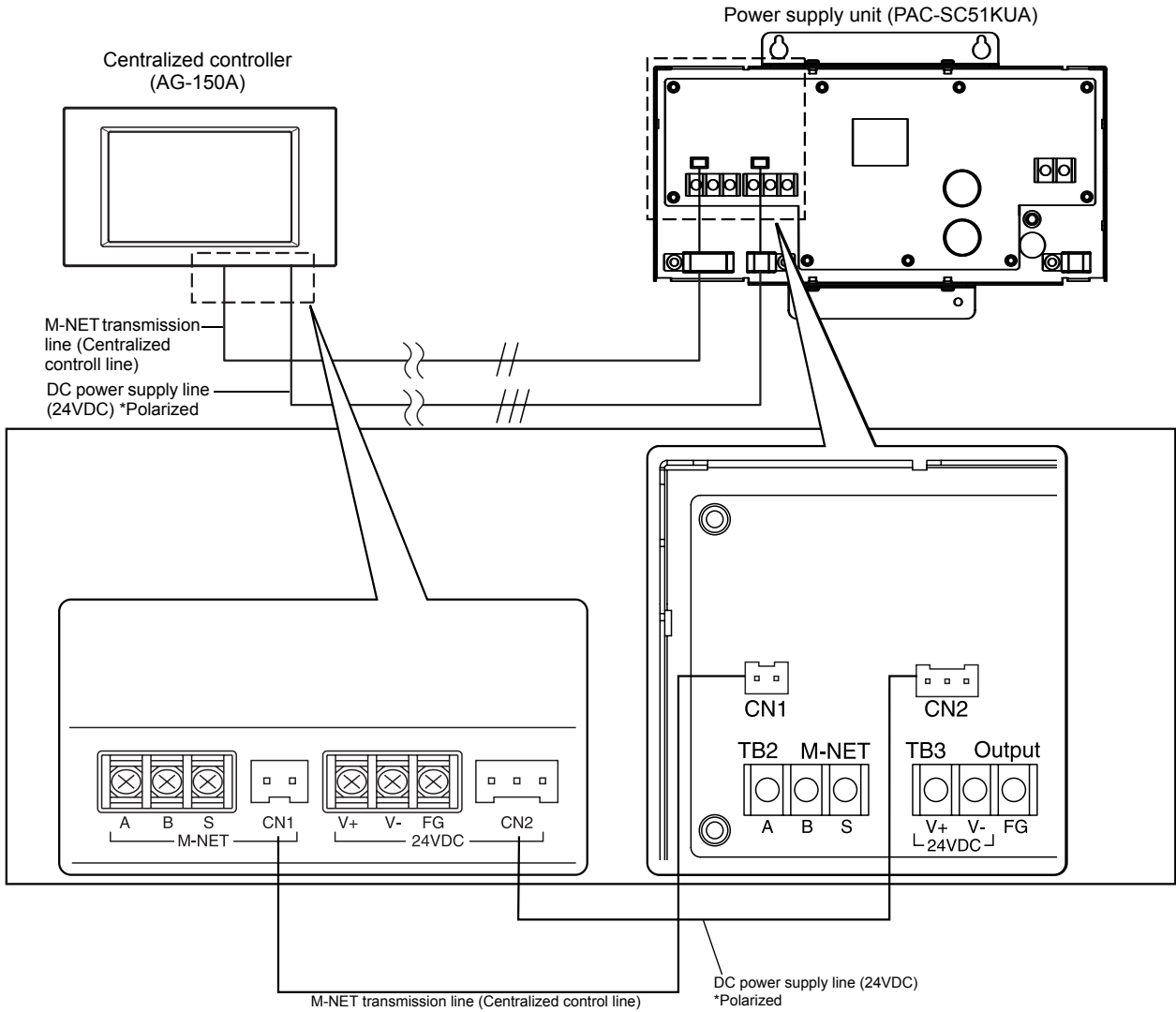

Fig. 4-4

CAUTION

- Both of PAC-SC51KUA and Outdoor unit can supply DC power to the M-NET transmission line. Set the outdoor unit central control system transmission line power supply to the factory setting CN41 (no supply). For further details, refer to the outdoor unit installation manual. Failure to do so may cause unit malfunction or fire.

After connection for the each cable, fasten each cable with the cable fixture.

- (2) With the use of an expansion controller (PAC-YG50ECA)
 Only connect the DC power cable. (Use only TB3 or CN2.)
 (a) Connected via the terminal block (TB3)

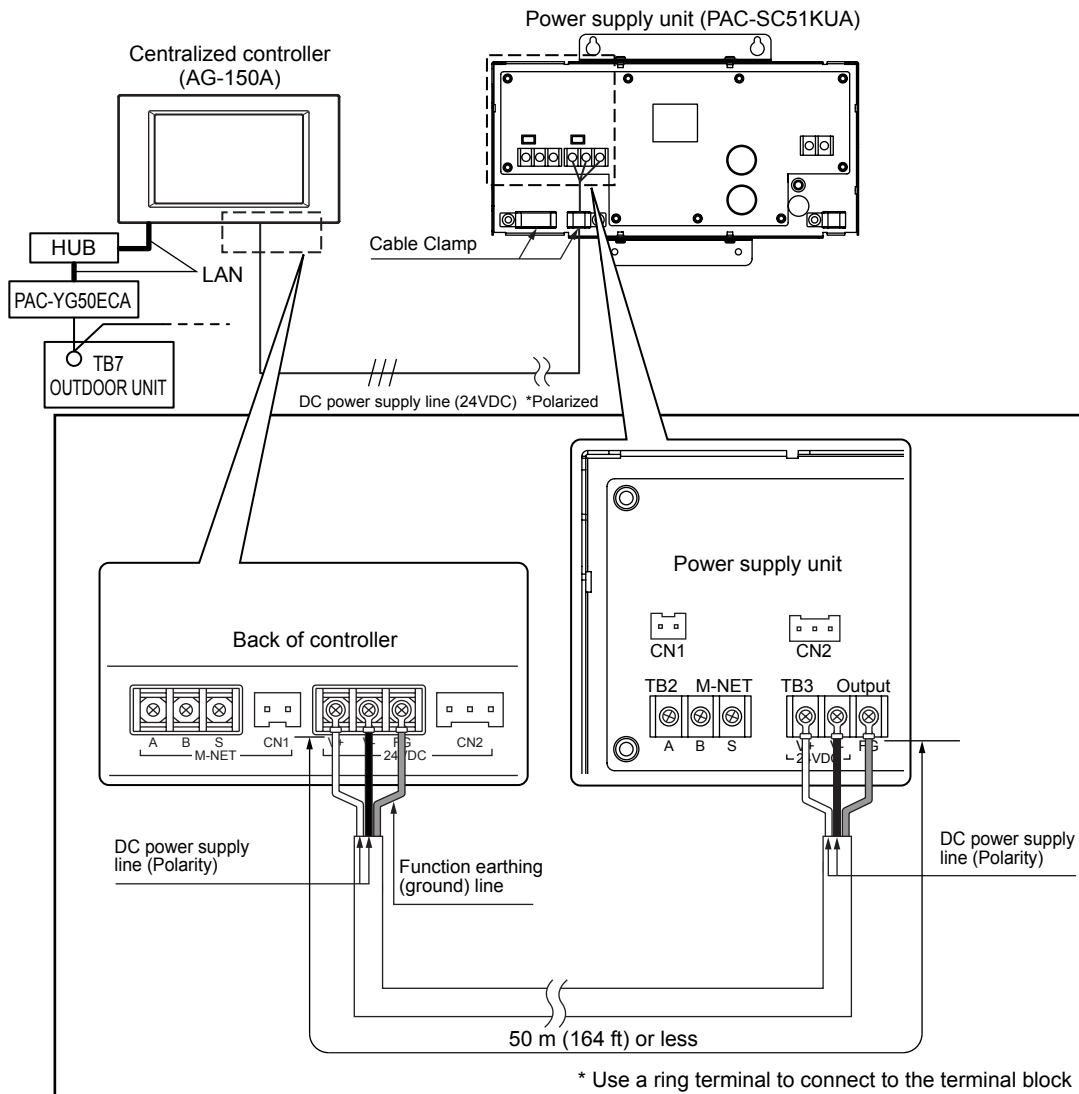

Fig. 4-5

(b) Connecting the connector (CN2)

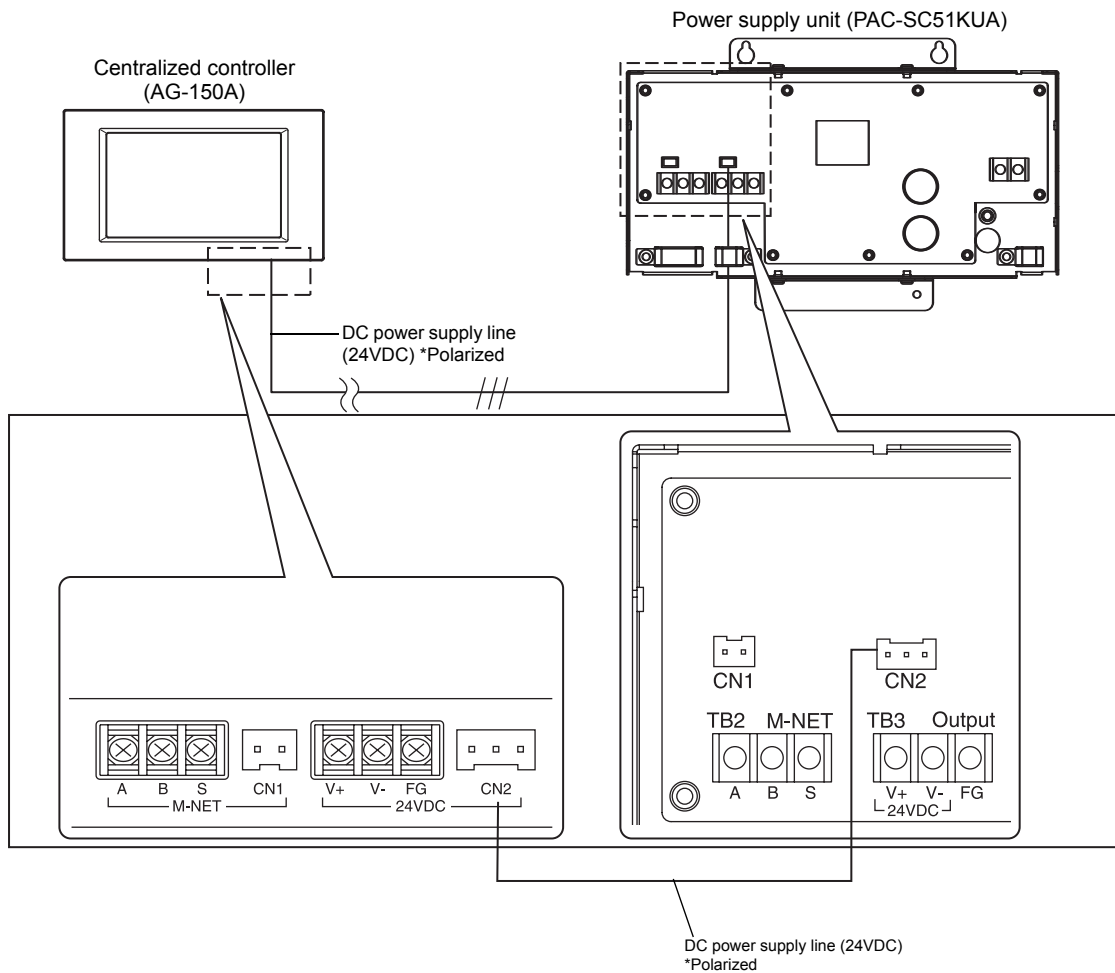

Fig. 4-6

After connection for the each cable, fasten each cable with the cable fixture.

3-2. When not connecting to the centralized controller (AG-150A)

Only use the M-NET output (TB2 or CN1).

CAUTION

- The 24 VDC power supply is for exclusive use with the centralized controller (AG-150A).

5 M-NET Transmission Lines Length

- Maximum length of M-NET transmission: $\leq 500\text{m}$ (1640 ft) *1
- Maximum power feeding length : $\leq 200\text{m}$ (656 ft)

NOTE

*1: If the remote control cable exceeds 10m (32 ft), the additional length must be added to the total in order to avoid exceeding the maximum length of the M-NET transmission specification.

Example

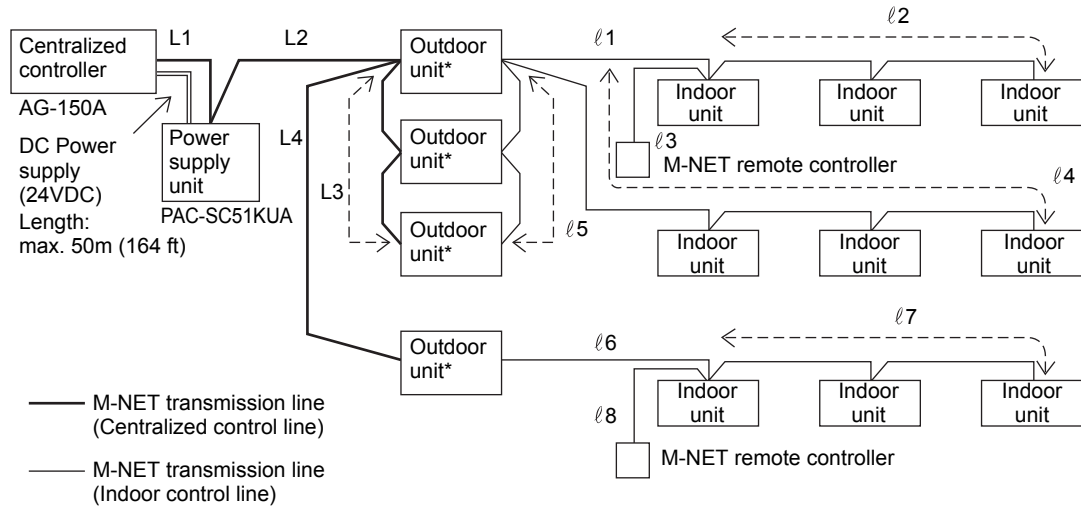

1) Maximum length of M-NET transmission line:

- ① $L1+L2+L3+\ell5+\ell1+\ell2$ ($\ell3$) $\leq 500\text{m}$ (1640 ft)
- ② $L1+L2+L3+\ell5+\ell4$ $\leq 500\text{m}$ (1640 ft)
- ③ $L1+L2+L4+\ell6+\ell7$ ($\ell8$) $\leq 500\text{m}$ (1640 ft)
- ④ $\ell2$ ($\ell3$) + $\ell1+\ell5+L3+L4+\ell6+\ell7$ ($\ell8$) $\leq 500\text{m}$ (1640 ft)
- ⑤ $\ell4+\ell5+L3+L4+\ell6+\ell7$ ($\ell8$) $\leq 500\text{m}$ (1640 ft)

2) Maximum power feeding length for the indoor control line:

- ① $\ell5+\ell1+\ell2$ ($\ell3$) $\leq 200\text{m}$ (656 ft)
- ② $\ell5+\ell4$ $\leq 200\text{m}$ (656 ft)
- ③ $\ell6+\ell7$ ($\ell8$) $\leq 200\text{m}$ (656 ft)

3) Maximum power feeding length for the centralized control line:

- ① $L1$ $\leq 200\text{m}$ (656 ft)*
- ② $L2+L3$ ($L4$) $\leq 200\text{m}$ (656 ft)

* To supply power to the M-NET line from PAC-SC51KUA, connect the power jumper on outdoor unit to CN41.

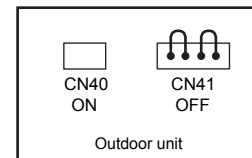

NOTE

If the remote control cable ($\ell3$, $\ell8$) does not exceed 10m (32 ft) in length, the length for $\ell3$, $\ell8$ may not need to be added to the total length.

*The total length of DC power cable must not exceed 50m (164 ft).

NOTE

This equipment has been tested and found to comply with the limits for a Class B digital device, pursuant to Part 15 of the FCC Rules. These limits are designed to provide reasonable protection against harmful interference in a residential installation. This equipment generates, uses and can radiate radio frequency energy and, if not installed and used in accordance with the instructions, may cause harmful interference to radio communications. However, there is no guarantee that interference will not occur in a particular installation.

If this equipment does cause harmful interference to radio or television reception, which can be determined by turning the equipment off and on, the user is encouraged to try to correct the interference by one or more of the following measures:

- Reorient or relocate the receiving antenna.
- Increase the separation between the equipment and receiver.
- Connect the equipment into an outlet on a circuit different from that to which the receiver is connected.
- Consult the dealer or an experienced radio/TV technician for help.

This product is designed and intended for use in the residential,
commercial and light-industrial environment.

The product at hand is
based on the following
EU regulations:

- Low Voltage Directive 2006/95/EC
- Electromagnetic Compatibility Directive,
2004/108/EC

Please be sure to put the contact address/telephone number on
this manual before handing it to the customer.

 **mitsubishi electric corporation**

HEAD OFFICE: TOKYO BLDG., 2-7-3, MARUNOUCHI, CHIYODA-KU, TOKYO 100-8310, JAPAN

Authorized representative in EU: MITSUBISHI ELECTRIC EUROPE B.V.

HARMAN HOUSE, 1 GEORGE STREET, UXBRIDGE, MIDDLESEX UB8 1QQ, U.K.