

## Air-conditioner Control System

# BM ADAPTER BAC-HD150

## *Installation Manual*



### Contents

	Page
<u>Safety Precautions</u> .....	2
1. Package Contents .....	5
2. Specifications .....	6
2-1. Product Specifications .....	6
2-2. External dimensions .....	6
2-3. Power supply function to the M-NET transmission line .....	7
3. Sample system configuration .....	8
3-1. System in which BAC-HD150 is connected to the M-NET line .....	8
3-2. Restrictions for using BAC-HD150 in combination with AG-150A .....	9
3-3. System in which BAC-HD150 is connected to the expansion controller .....	10
3-4. Restrictions for using BAC-HD150 in combination with other controllers .....	11
3-5. Setting M-NET address for various devices .....	12
4. Installation .....	14
4-1. Required parts .....	14
4-2. M-NET transmission line length .....	15
4-3. Installation .....	16
5. Wiring connections .....	17
5-1. Installing and uninstalling the cover .....	17
5-2. Connecting the power cable and protective earth cable .....	17
5-3. Connecting the M-NET transmission lines .....	18
5-4. Connecting the LAN cable .....	20
6. Making the initial settings .....	21
7. Test run .....	21

BACnet® is a registered trade mark of ASHRAE  
(American Society of Heating, Refrigerating, and  
Air-Conditioning Engineers, Inc.).

# Safety Precautions

- Thoroughly read this installation manual before use to ensure safety.
- Before installing the BAC-HD150, read the Safety Precautions section carefully to ensure proper installation.
- Observe these precautions carefully to ensure safety.

 <b>WARNING</b>	Indicates a risk of death or serious injury.
 <b>CAUTION</b>	Indicates a risk of injury or structural damage.

- After reading this manual, pass the manual on to the end user to retain for future reference.
- The users should keep this manual for future reference and refer to it as necessary. This manual should be made available to those who repair or relocate the units. Make sure that the manual is passed on to any future air condition system users.

**Electric work must be performed by an authorized technician.**

 **WARNING**

## Installation

<p><b>To reduce the risk of fire and electric shock, do not install the units where they can get wet.</b></p>	<p><b>Properly install the unit on a stable, load-bearing surface.</b> Unit installed on an unstable surface may fall and cause injury.</p>
<p><b>To reduce the risk of electric shock, fire, and malfunction, do not install the unit in a steamy or condensing environments.</b></p>	<p><b>Units must be properly installed by your dealer or authorized technician according to the instructions in the Installation Manual.</b> Improper installation may result in electric shock or fire.</p>
<p><b>Properly dispose of the packing materials.</b> Plastic bags can pose suffocation and choking hazards. Keep out of the reach of children. Tear the plastics bags before disposing of them.</p>	

## Wire installation

<p><b>Properly secure the cables with clamps so that the weight of the cables will not strain the connectors.</b> Improperly connected cables may break, produce heat, and cause smoke or fire.</p>	<p><b>To reduce the risk of electric leak, overheating, and fire, only use standard cables with the proper current carrying capacity.</b></p>
<p><b>Electric work must be performed by an authorized technician according to the local regulations and the instructions detailed in this manual. Always use a dedicated circuit.</b> Capacity shortage to the power supply circuit or improper installation may result in electric shock, smoke, or fire.</p>	<p><b>Use properly rated breakers (residual current circuit breaker (RCCB), main switch + fuse, circuit breaker).</b> The use of improperly rated breakers may result in malfunctions or fire.</p>
<p><b>Install all required covers.</b> Infiltration of dust or water may cause electric shock, smoke, or fire.</p>	<p><b>To reduce the risk of electric shock and malfunctions, keep wire pieces and sheath shavings out of the terminal block.</b></p>
<p><b>Take appropriate measures against electrical noise interference when installing the air conditioners in hospitals or radio communication facilities.</b></p> <ul style="list-style-type: none"> <li>• Inverter, power generators, or radio communication equipment may interfere with the normal operation of the unit.</li> <li>• Subsequently, the device may also affect medical treatment, image broadcasting by creating frequency noise.</li> </ul>	<p><b>This appliance must be earthed.</b> Do not connect the protective earth cable to a gas pipe, water pipe, lightning rod, or telephone earthing cable. If the unit is not properly earthed, the unit may malfunction due to electrical noise interference. It also poses a risk of electric shock, smoke, or fire.</p>
<p><b>Make sure that there is a main power switch and residual current circuit breaker (RCCB) for each unit.</b> A ready accessible breaker for power source line helps reduce the risk of electric shock. Installation of a breaker is mandatory in some area.</p>	

## General caution

**Do not install the unit in environments where large amounts of oil (including machine) or acidic/alkaline chemical sprays are present. These types of substances may cause device performance to be reduced and cause electrical shock, malfunction, smoke, or fire.**

**To reduce the risk of electric shock, fire, or malfunction, do not wash the unit with water or other types of liquids.**

### **Wear protective gloves.**

A high voltage is applied to the terminals. To reduce the risk of electric shock, wear protective gloves before touching the electrical parts on the unit.

## Relocating/Repairing units

**Consult your dealer or an authorized technician when the unit needs to be relocated or repaired.**

**Do not disassemble the unit or make any modifications/alterations to the unit.**

Improper repair, modification, or alteration may cause injury, electric shock, or fire.

## **CAUTION**

## Transporting units/Unit installation

**Do not install the unit where there is a risk of leaking flammable gas.**

If flammable gas accumulates around the unit, it may ignite and cause a fire or explosion.

**Take appropriate safety measures against earthquakes to prevent the unit from toppling over.**

Unit installed on an unstable surface may fall and cause injury.

**To reduce the risk of fire and malfunctions and to keep the unit from falling, do not install the unit where the unit may receive vibration or mechanical shock.**

## Electric work

**Do not touch switches or other electrical parts with wet hands.**

Doing so poses a risk of fire or electric shock.

## General caution

**To reduce the risk of electric shock, turn off the power before performing electric work.**

**To reduce the risk of injury, do not touch the edges of parts.**

**When replacing fuses, only use fuses with adequate breaking capacity.**

The use of improperly rated fuses or a substitution of fuses with steel or copper wire may result in fire.

**To reduce the risk of injury from accidentally dropped tools, check the surroundings before performing installation, inspection, and repairs, and keep children away from the site.**

 **Important**

**To avoid deformation and malfunction, do not install the unit in direct sunlight or where the ambient temperature exceeds 55°C (131°F) or drops below -10°C (14°F).**

**Always use adequate tools for repair.**

The use of unsuitable tools may result in failure to complete the job properly and cause unit damage or injury.

**When connecting to the Internet, manage the security of the Internet.**

To prevent unauthorized access, always use a security device such as a VPN router when connecting to the Internet.

**To avoid malfunctions, do not bundle the power cable and signal transmission lines together, or put them in the same conduit.**

**To avoid fire, malfunction, and damage, do not connect the power cable to terminal block for signal cables.**

**This appliance is not intended for use by persons (including children) with reduced physical, sensory or mental capabilities, or lack of experience and knowledge, unless they have been given supervision or instruction concerning use of the appliance by a person responsible for their safety.**

**Children should be supervised to ensure that they do not play with the appliance.**

# 1 Package Contents

- Check that the following parts are included in the package.

No.	Item	Usage	Qty
①	BM ADAPTER (BAC-HD150) 	BAC-HD150 is a protocol converter that enables the centralized control/operation of CITY MULTI air conditioners. By connecting this unit to the BACnet <sup>®</sup> building management system, it can control up to 50 units. (*)	1
②	Installation Manual (this document)	Describes how to install BAC-HD150.	1
③	Instructions Book	Explains how to make the initial settings for BAC-HD150 and how to test run the system.	1
④	Setting Tool CD	Contains the software to set up BAC-HD150 and an Instruction Manual file. Use them to initially set up the addresses for BAC-HD150 and configure an air conditioning system.	1

**Note**

\* Expansion controllers (PAC-YG50ECA; separately sold) can be connected to BAC-HD150 to control up to 150 units. Up to 3 PAC-YG50ECA can be connected to each BAC-HD150.  
 Refer to section 3-3. "System in which BAC-HD150 is connected to the expansion controller" for details.

## 2 Specifications

### 2-1. Product Specifications

Items		Specifications	
Power source	Rated input	100-240 VAC $\pm 10\%$ 0.4-0.3 A 50/60 Hz	
	Fuse	250 VAC 3.15 A Time-delay type (IEC127-2 S.S.5)	
Interface	Rated output of the power supply to M-NET transmission lines	22-30 VDC	
	LAN 1 (for BACnet <sup>®</sup> ) LAN 2 (for Expansion Controller)	10Base-T or 100Base-TX	
Ambient conditions	Temperature	Operating temperature range	-10 ~ 55°C (14 ~ 131°F)
		Storage temperature range	-20 ~ 60°C (-4 ~ 140°F)
	Humidity		30 ~ 90 %RH (Non-condensing)
Dimensions		266 (H) × 250 (W) × 97.2 (D) mm (10-1/2 (H) × 9-7/8 (W) × 3-7/8 (D) in.)	
Weight		2.8 kg (6-3/16 lbs.)	
Installation conditions		Inside the metal control panel (indoor)	

### 2-2. External dimensions

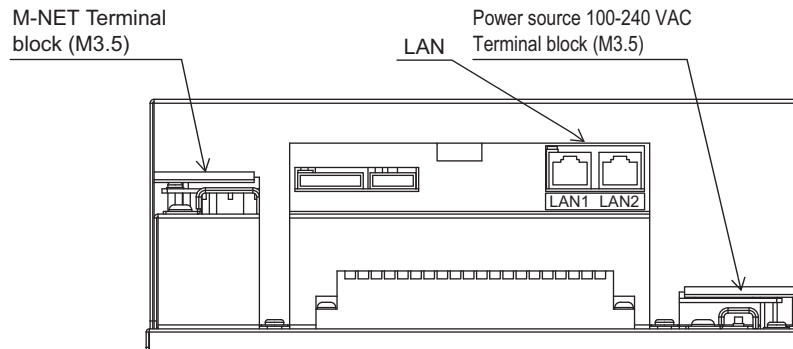
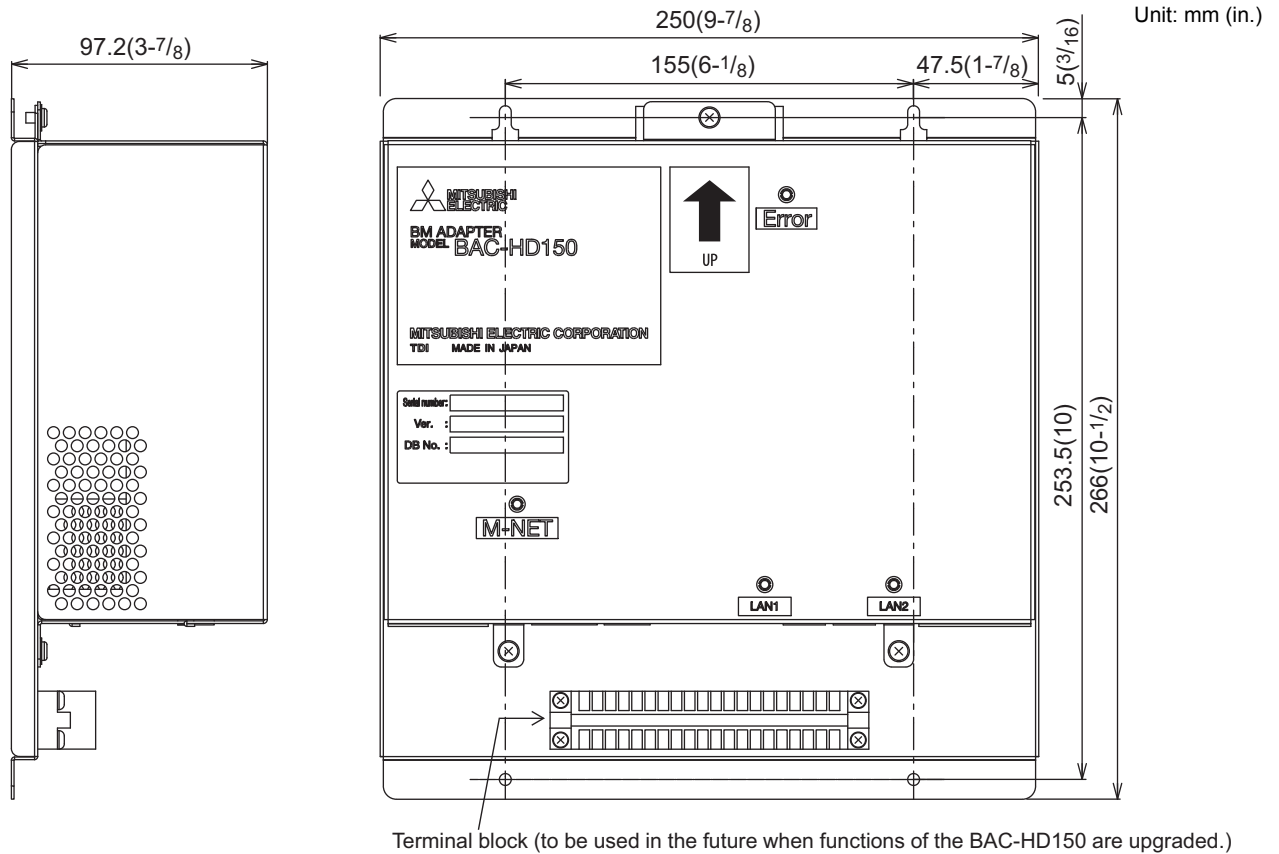

### 2-3. Power supply function to the M-NET transmission line

BAC-HD150 has a built-in function to supply power to the M-NET transmission line. (power supply coefficient: 6)  
 When power is supplied from BAC-HD150, the total power consumption coefficient of the system controller and M-NET remote controller to which BAC-HD150 supplies power (See table 1) should not exceed the power supply coefficient of BAC-HD150, which is six.

Table 1 Power consumption coefficient of the controller

System controller		M-NET remote controller
ON/OFF remote controller	System remote controller Schedule timer Group remote controller	ME remote controller LOSSNAY remote controller
1	0.5	0.25

Table 2 No. of connected units

System controller		M-NET remote controller
ON/OFF remote controller	System remote controller Schedule timer Group remote controller	ME remote controller LOSSNAY remote controller
6 units	12 units	24 units

Table 3 No. of connected units in systems with various combinations of remote controllers

V: connectable

		Total number of ON/OFF remote controllers						
		0	1	2	3	4	5	6
Total number of system remote controllers, schedule timers, and group remote controllers combined	0	V	V	V	V	V	V	V
	1	V	V	V	V	V	V	
	2	V	V	V	V	V	V	
	3	V	V	V	V	V		
	4	V	V	V	V	V		
	5	V	V	V	V			
	6	V	V	V	V			
	7	V	V	V				
	8	V	V	V				
	9	V	V					
	10	V	V					
	11	V						
	12	V						

### 3 Sample system configuration

#### 3-1. System in which BAC-HD150 is connected to the M-NET line

The figure below only shows the transmission line connections. Power supply lines are omitted.

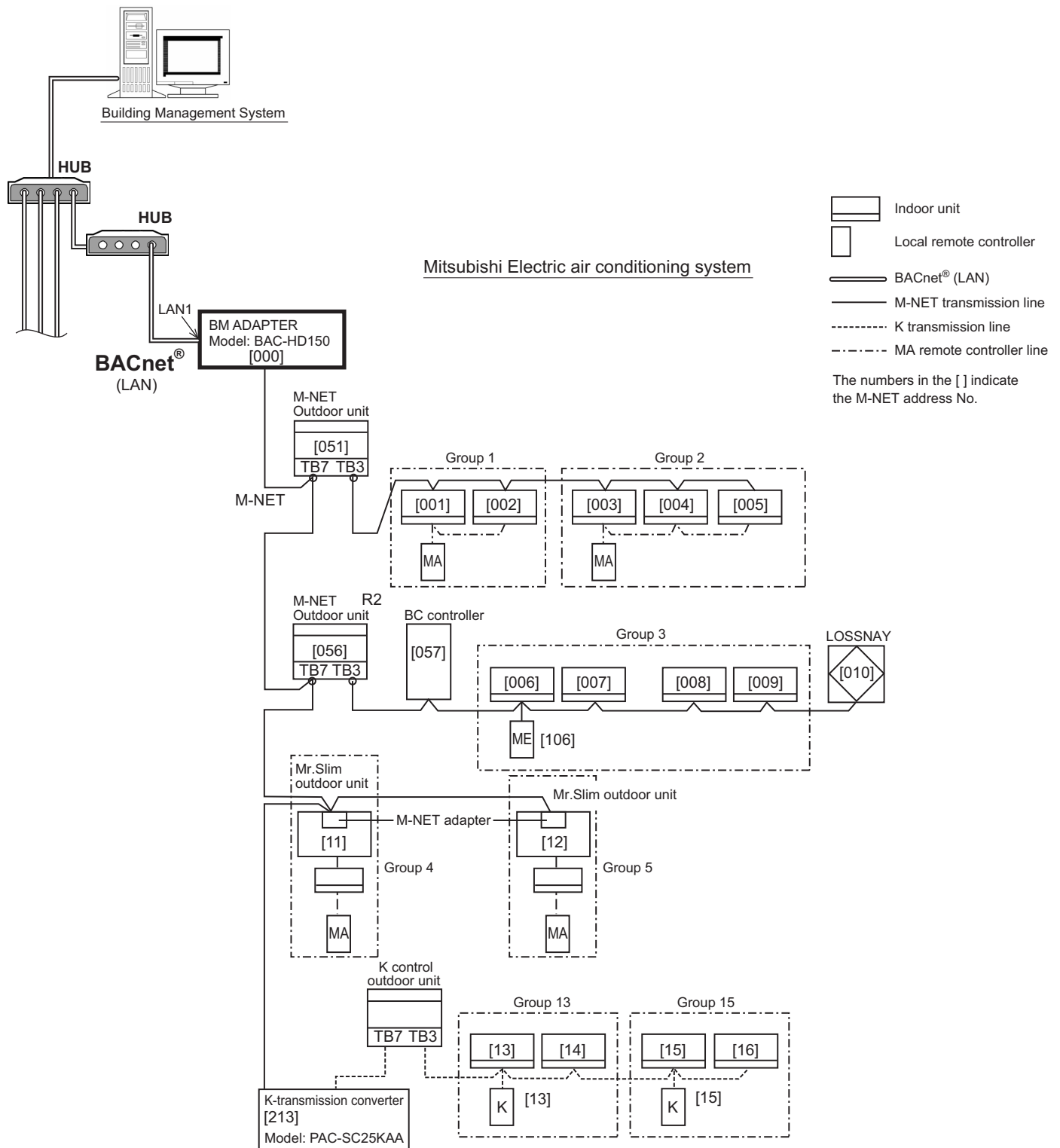

#### Note

- Use a switching HUB.
- Provide "one-point grounding" for the M-NET transmission line (centralized control system) by grounding the shield of the BAC-HD150.  
Ground the indoor-outdoor transmission line in each outdoor unit refrigerant system.
- Set the centralized control switch (SW2-1) on the outdoor units on the M-NET line to ON.  
(Refer to the outdoor unit Installation Manual for the details of the dipswitch settings.)



### 3-2. Restrictions for using BAC-HD150 in combination with AG-150A (When BAC-HD150 is connected to the M-NET line)

When AG-150A and BAC-HD150 are connected to the M-NET line, note that the number of connectable controllers and the compatible software versions are limited.

If the software version is not compatible, update the software version of the controllers.

Unless AG-150A and/or PAC-YG50ECA support the dual set point function, BAC-HD150 is not also available for the dual set point function (AV\_XXXX24-28).

Refer to the Instruction Manual with regard to AV\_XXXX24-28.

- (1) Restrictions on the number of connectable units  
Only one BAC-HD150 can be connected to the M-NET line.  
Only one AG-150A can be connected to BAC-HD150.
- (2) Compatible software versions and the number of connectable controllers

The number of connectable controllers	AG-150A	None	1 unit
	BAC-HD150	1 unit	1 unit
Software version	AG-150A	-	Ver. 2.30 or later
	BAC-HD150	Ver. 1.00 or later	Ver. 2.00 or later

- (3) Restrictions on the DB No.  
None

- (4) Miscellaneous restrictions  
If a main system controller, such as AG-150A, is used in combination with a BAC-HD150, there will be many restrictions on the settings, such as group settings. Please consult your dealer for more information.

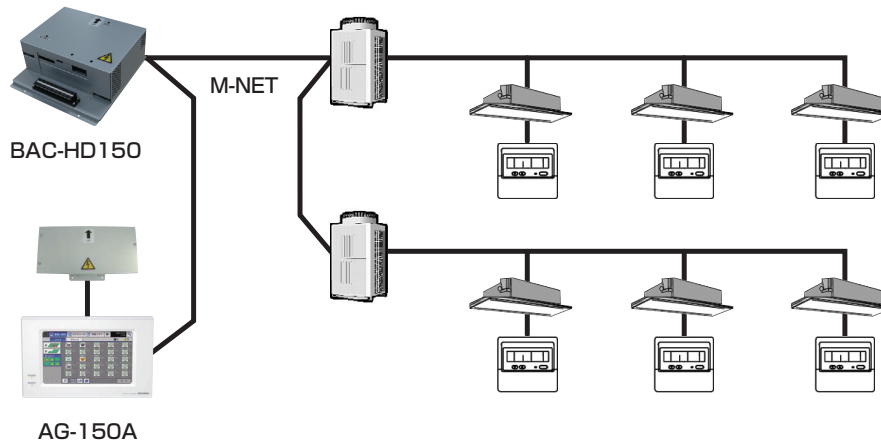

### 3-3. System in which BAC-HD150 is connected to the expansion controller

The figure below only shows the transmission line connections. Power supply lines are omitted.

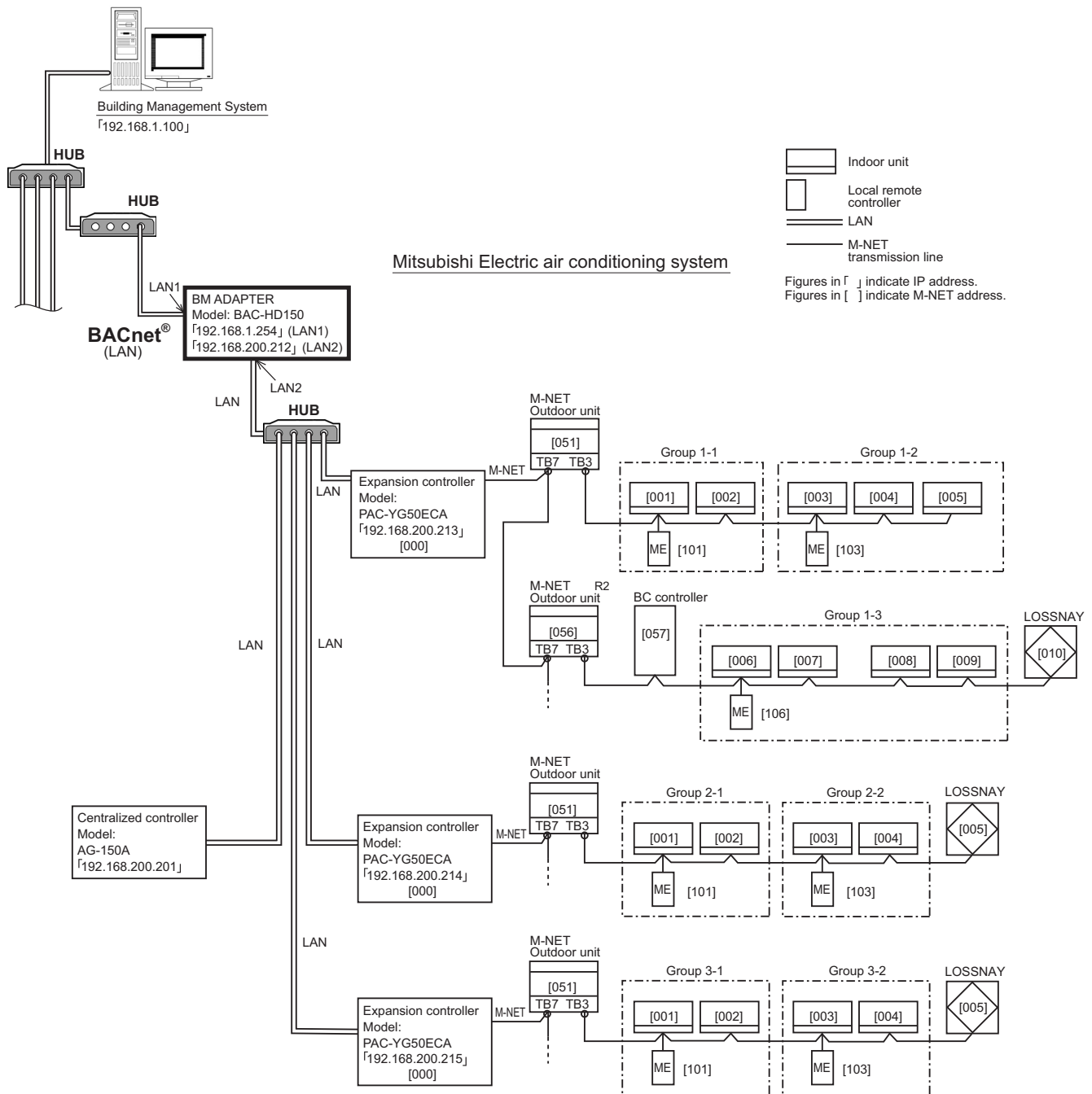

- Refer to the PAC-YG50ECA Installation/Instructions Manual for how to set the IP address.
- The same M-NET address cannot be used twice in the same M-NET system that connects to the same PAC-YG50ECA.

#### NOTES

\* The BAC-HD150 and the type of controllers that connect to the expansion controller via the LAN (e.g., AG-150A) each have a DB No. This 2-digit number is indicated on the package box and the controller. ([DB No.:\*\*])  
 Controllers with different DB No. cannot be connected to each other. Be sure to check the DB No. of each controller to be connected.  
 Connection of two or more controllers that have different DB No. requires a controller software version update. Consult your dealer for how to update the software.

#### Label contents

Serial number : \* \* \* \* \* - \* \* \* \*  
 Ver. : \* \* . \* \* \*  
 DB No. : \* \*

DB No. appears here.

<Ver.>と<DB No.>は出荷時点のものを記載しています。  
 <Ver.> and <DB No.> indicate factory default versions.

- \* Use a switching HUB.
- \* Provide "one-point grounding" for the M-NET transmission line (centralized control system) by grounding the shield of each expansion controller.  
 Ground the indoor-outdoor transmission line in each outdoor unit refrigerant system.
- \* Set the centralized control switch (SW2-1) on the outdoor units on the M-NET line to ON.  
 (Refer to the outdoor unit Installation Manual for the details of the dipswitch settings.)

### 3-4. Restrictions for using BAC-HD150 in combination with other controllers (When BAC-HD150 is connected to the expansion controller)

After AG-150A or other controllers are connected to an air conditioning system, each controller can control the system.

Note that the number of connectable controllers and compatible software versions are limited.

If the software version is not compatible, update the software version of the controllers.

Unless AG-150A and/or PAC-YG50ECA support the dual set point function, BAC-HD150 is not also available for the dual set point function (AV\_ xxxx24-28).

Refer to the Instruction Manual with regard to AV\_ xxxx24-28.

#### (1) Restrictions on the number of connectable units

Only one BAC-HD150 can be connected to the M-NET line.

Note that the BAC-HD150 cannot be connected to the expansion controller unless the AG-150A is also connected to the expansion controller.

The total number of AG-150A and BAC-HD150 units must be three or less.

Up to three expansion controllers can be connected to one BAC-HD150 unit.

#### (2) Compatible software versions and the number of connectable controllers

The number of connectable controllers	PAC-YG50ECA	3 units or less
	AG-150A	1 or 2 units
	BAC-HD150	1 unit
Software version	PAC-YG50ECA	Ver. 1.30 or later
	AG-150A	Ver. 2.30 or later
	BAC-HD150	Ver. 2.00 or later

#### (3) Restrictions on the DB No.

Controllers with different DB No. cannot be connected to each other.

When DB No. on the controllers is different, update the software version of the controllers.

#### (4) Miscellaneous restrictions

Use AG-150A to make group settings and interlocked ventilation settings.

Consult your dealer for details.

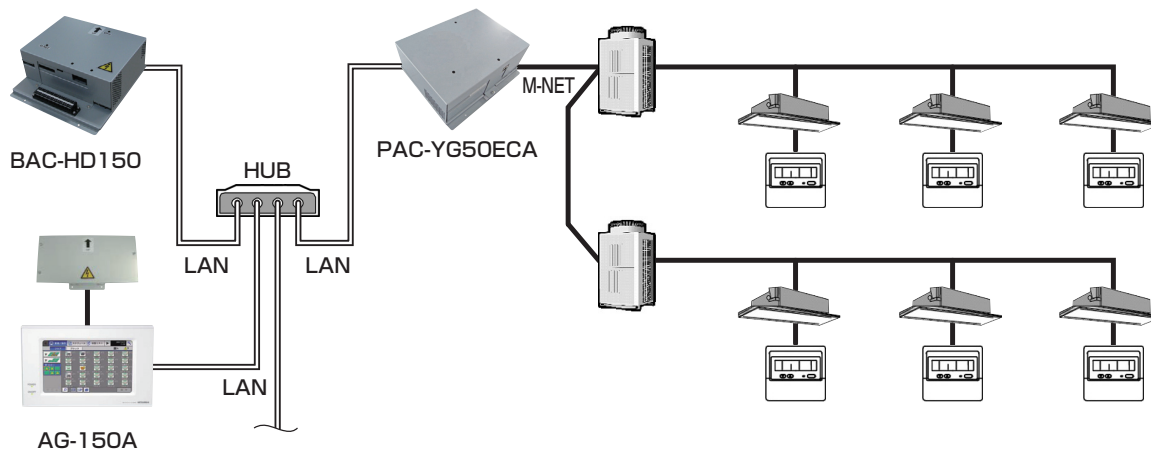

### 3-5. Setting M-NET address for various devices

The same address cannot be used more than once within a M-NET system. (The address overlap between K-control unit and K-control remote controller is excluded.)

	Address setting method	M-NET address
Indoor unit	Assign the lowest address to the main indoor unit in the group, and assign sequential addresses to the rest of the indoor units in the same group.	1 ~ 50
Outdoor unit	Assign an address that equals the lowest indoor unit address in the group plus 50.	51 ~ 100
Auxiliary outdoor unit (BC controller)	Assign an address that equals the address of the outdoor unit in the same refrigerant system plus 1.	52 ~ 100
OA processing unit/ LOSSNAY	Assign an arbitrary but unused address to each of LOSSNAY units after assigning an address to all indoor units.	1 ~ 50
Mr.Slim outdoor unit (A-control)	Set the address in the same way as with the indoor units. An M-NET adapter (sold separately) is required.	1 ~ 50
Air To Water Booster unit/ Air To Water HEX unit	Set the address in the same way as with the indoor units.	1 ~ 50
M-NET remote controller	Assign an address that equals the address of the main indoor unit with the lowest address in the group plus 100. Add 150 in stead of 100 to set a sub remote controller.	101 ~ 200
MA remote controller	Address setting is not required. Connection of two remote controllers requires the main/sub setting for each controller to be made.	-
Sub system controller	Assign an address that equals the lowest number of the group to be controlled +200.	201 ~ 250
K-control indoor unit	Assign an address to all M-NET indoor units (incl. LOSSNAY units) first, and then assign addresses to the K-control indoor unit, starting with the address after the last address.	1 ~ 50
K-control remote controller	Assign the same address as the lowest main K-control indoor unit address within the same group.	1 ~ 50
K-transmission converter	Assign an address that equals the lowest address of the K-control indoor units +200.	201 ~ 250

<b>Important</b>	<ul style="list-style-type: none"> <li>● Note the following when using a K-transmission converter (Model: PAC-SC25KAA) to control the K-control model units. Refer to the K-transmission converter Installation manual for details.               <ol style="list-style-type: none"> <li>① Be sure to set the BAC-HD150 address to "000."</li> <li>② Be sure to set the K-control air conditioning unit connection setting on the BAC-HD150 to Yes (set via the Setting Tool). When the above setting is made, enter the K-transmission converter address.</li> <li>③ Assign addresses to the K-control air conditioners so that they are larger than the addresses that are assigned to the M-control indoor units.</li> <li>④ When making the group settings for the K-control units, make the group number and the lowest address of the indoor units within the group the same.</li> <li>⑤ If the K-control Y series units and other types of units (K-control Mr. Slim) are used in combination, a relay board is required. The K-control Y series units cannot be connected to the same transmission lines as the other types of units.</li> <li>⑥ Depending on the number of K-control units and transmission line length, a relay board may be required. Refer to the System Design/Manual (control version) for details.</li> <li>⑦ LOSSNAY units cannot be connected if they are connected to the K-control kit.</li> <li>⑧ Remote controller addresses do not need to be included in the group setting for the K-control units.</li> </ol> </li> </ul>
------------------	---

<b>Note</b>	<ul style="list-style-type: none"> <li>● A-control jet burner models cannot be controlled.</li> <li>● Some models of units (e.g., DIDO, PI, and AI controller) cannot be controlled.</li> <li>● Each PAC-YG50ECA can control up to 50 units.</li> <li>● Main system controllers (e.g., BAC-HD150) cannot be connected to an M-NET system that is controlled by the expansion controller.</li> </ul>
-------------	---

\* Main and sub system controllers (M-NET)

BAC-HD150 can only be used as the main system controller, but not as a sub system controller.

- Main system controller (Main SC)  
Main SC refers to a controller that controls all other system controllers including the units they control. If a given system has only one system controller, that controller becomes the main SC. Group settings and interlock settings can only be made from a main SC.
- Sub system controller (Sub SC)  
Sub SC refers to a system controller that is controlled (including the units it controls) by a main SC.

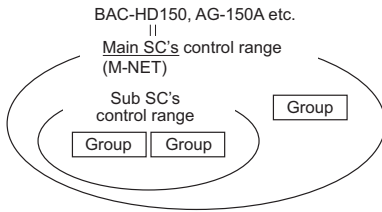

BAC-HD150 is exclusively for use as a main SC. It cannot be used as a sub SC or controlled from a main SC.

**Note**

The system cannot be configured in the following way.

- Groups that are not under the control of a main SC cannot be controlled from a sub SC.

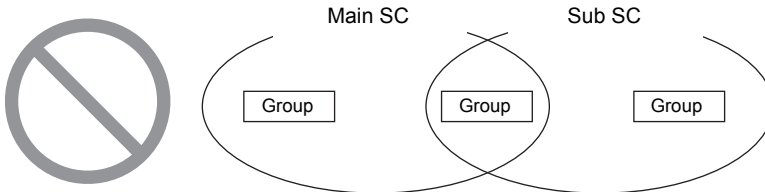

- Each group cannot be under the control of two or more main SC.

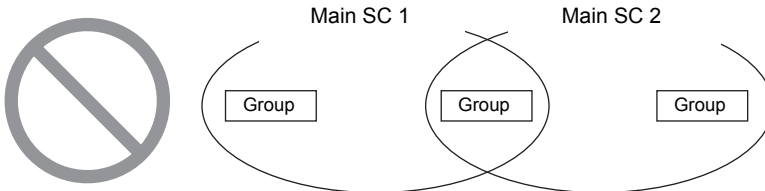

- Sub SC cannot be under the control of two or more main SC.

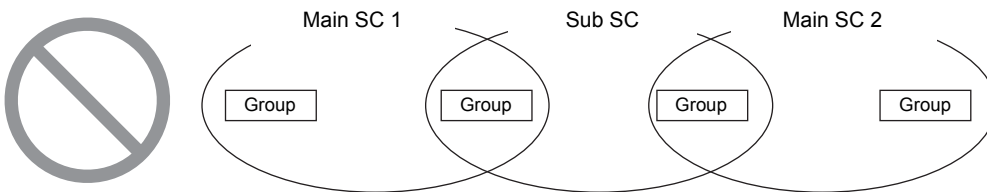

## 4 Installation

### 4-1. Required parts

The following parts are required to install the unit.

Required parts	Specification								
Power cable/ Protective earth cable	Power supply cable of appliances shall not be lighter than design 245 IEC 57 or 227 IEC 57. Cable size:0.75mm <sup>2</sup> to 2mm <sup>2</sup>								
M-NET transmission line	Shielded cable <ul style="list-style-type: none"> <li>• CPEVS: <math>\phi</math>1.2mm to <math>\phi</math>1.6mm</li> <li>• CVVS: 1.25mm<sup>2</sup> to 2mm<sup>2</sup></li> </ul>								
Ring terminal (with a sleeve)	M3.5 terminal (used with the power cable (L/L1, N/L2), M-NET transmission line (A, B, S)) M4 ring terminal (used with the protective earth cable)								
Screw	Have four M4 screws ready to install the unit.								
LAN cable	10Base-T or 100Base-TX (category 5 or above) straight cable (Maximum 100m (328 ft))								
HUB	Switching HUB (communication speed: 10 Mbps or 100 Mbps)								
Overcurrent breaker and Residual Current Circuit Breaker (RCCB)	Install an overcurrent breaker and a residual current circuit breaker (RCCB) for each BAC-HD150 unit.								
	<table border="1" style="width: 100%; border-collapse: collapse;"> <thead> <tr> <th colspan="2">Overcurrent breaker</th> <th>Residual Current Circuit Breaker (RCCB)<sup>*1</sup></th> </tr> </thead> <tbody> <tr> <td style="text-align: center;">Fuse</td> <td style="text-align: center;">Circuit breaker<sup>*1</sup></td> <td rowspan="2" style="text-align: center;">Rated current: 3A Rated sensitivity current: 30mA Maximum operation time: 0.1 sec or less</td> </tr> <tr> <td style="text-align: center;">Rated current: 3A<sup>*2</sup></td> <td style="text-align: center;">Rated current:3A</td> </tr> </tbody> </table>	Overcurrent breaker		Residual Current Circuit Breaker (RCCB) <sup>*1</sup>	Fuse	Circuit breaker <sup>*1</sup>	Rated current: 3A Rated sensitivity current: 30mA Maximum operation time: 0.1 sec or less	Rated current: 3A <sup>*2</sup>	Rated current:3A
	Overcurrent breaker		Residual Current Circuit Breaker (RCCB) <sup>*1</sup>						
Fuse	Circuit breaker <sup>*1</sup>	Rated current: 3A Rated sensitivity current: 30mA Maximum operation time: 0.1 sec or less							
Rated current: 3A <sup>*2</sup>	Rated current:3A								
<p><sup>*1</sup> Use a circuit breaker and a residual current circuit breaker (RCCB) of bipolar type (2P2E). Use a breaker with the minimum contact distance of 3 mm (1/8 in.).</p> <p><sup>*2</sup> When using a fuse, use it in combination with a main switch (Rated current: 3A).</p>									

## 4-2. M-NET transmission line length

- Connect the BAC-HD150 to the transmission line for centralized control (TB7 on the outdoor unit).
- There should only be one power supply source within a single transmission circuit. The factory setting is that power is not supplied from the BAC-HD150.
- Connect the shield of the M-NET transmission line for centralized control to the S terminal of TB3. Provide an earth for the indoor-outdoor transmission lines at one single outdoor unit.
- Maximum line distance Maximum 500 m/1,640 ft\*<sup>1</sup>
- Maximum power supply distance Maximum 200 m/656 ft\*<sup>1</sup>

Maximum power supply distance is the distance in which a power supply unit (or an outdoor unit designated as a power supply unit) is capable of supplying power to other units on the receiving end, such as remote controllers and indoor units.

Sample wiring connection

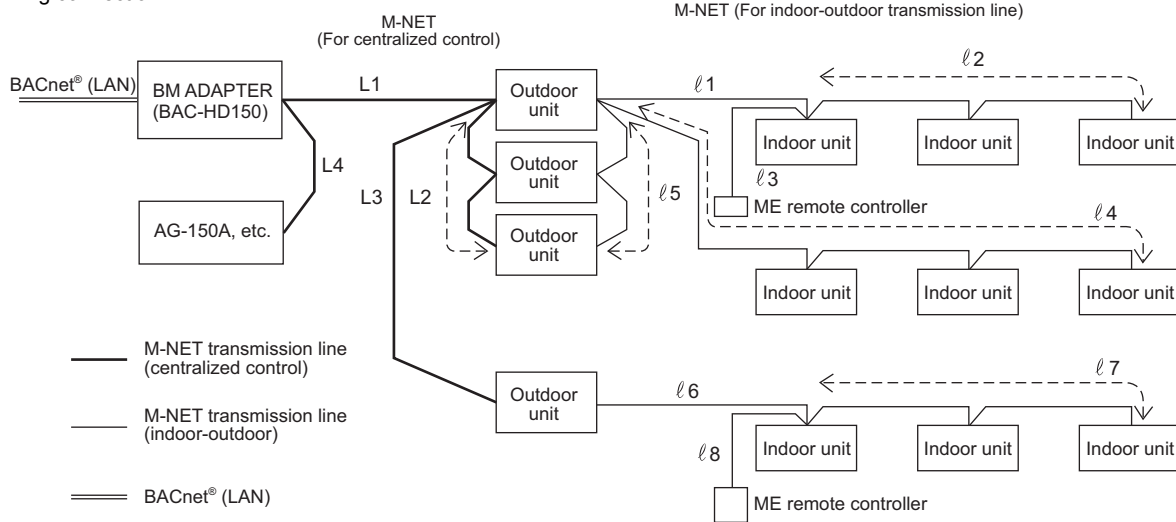

### (1) Maximum line distance

- ①  $L1 + L2 + l5 + l1 + l2 (l3) \leq 500 \text{ m/1,640 ft}$
- ②  $L1 + L2 + l5 + l4 \leq 500 \text{ m/1,640 ft}$
- ③  $L1 + L3 + l6 + l7 (l8) \leq 500 \text{ m/1,640 ft}$
- ④  $l2 (l3) + l1 + l5 + L2 + L3 + l6 + l7 (l8) \leq 500 \text{ m/1,640 ft}$
- ⑤  $l4 + l5 + L2 + L3 + l6 + l7 (l8) \leq 500 \text{ m/1,640 ft}$

\* To supply power from the BAC-HD150, check that the power jumper is connected to CN41 on the outdoor unit. Refer to section 5-3 for details.

### (2) Power supply distance for the indoor-outdoor transmission lines

- ①  $l5 + l1 + l2 (l3) \leq 200 \text{ m/656 ft}$
- ②  $l5 + l4 \leq 200 \text{ m/656 ft}$
- ③  $l6 + l7 (l8) \leq 200 \text{ m/656 ft}$

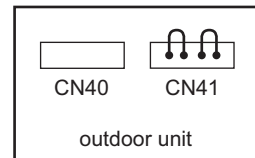

### (3) Power supply distance for the centralized control transmission lines

- ①  $L1 + L2 + L4 \leq 200 \text{ m/656 ft}$
- ②  $L1 + L3 + L4 \leq 200 \text{ m/656 ft}$

#### Note

\*1 The ME remote controller wiring length ( $l3$ ,  $l8$ ) should be 10 m (32 ft) or less. The length that exceeds 10 m (32 ft) needs to be included in the maximum distance to the farthest unit (500 m/1,640 ft) and the maximum power supply distance (200 m/656 ft). If the ME remote controller wiring length ( $l3$ ,  $l8$ ) is 10 m (32 ft) or less, it does not need to be included in the distance to the farthest unit or the power supply distance.

### 4-3. Installation

- Leave enough space around the unit to allow for an installation/uninstallation of the cover. (The amount of space needed is shown in the figure below.)
- Screw down the cover with M4 screws as shown in the figure below.  
Be sure to fix the four corners to prevent it from falling.
- Install on the metal control panel (indoors) with an effective depth of at least 105mm (4-3/16 in.).

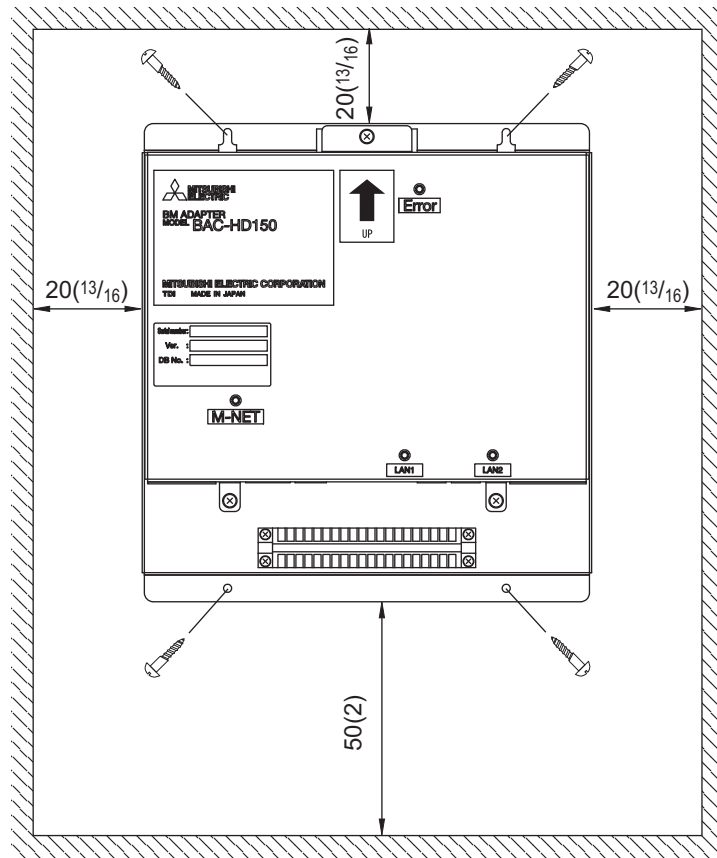

Unit: mm (in.)

\* Refer to section [2](#) Specifications for the product dimensions and weight.

**Properly install the unit on a stable, load-bearing surface.**  
Unit installed on an unstable surface may fall and cause injury.

**This product is not water-proof. Be sure to install the unit inside the metal control panel (indoors).**

**To reduce the risk of wire shorting, fire, electric shock, and malfunction, do not install the unit in a condensing environment, and keep the unit out of water and other sources of water.**



## 5 Wiring connections

- ⚠ WARNING**
- Electric work must be performed by an authorized technician. Improper wiring work may result in electric shock or fire.
  - Turn off the power supply before performing wiring work.
- ⚠ CAUTION**
- To avoid damage to the terminal block, do not connect an AC power supply (100-240 VAC) to the M-NET transmission line terminal block.

### 5-1. Installing and uninstalling the cover

Unscrew the three screws on the cover to remove it as shown in the figure below. Reinstall the cover using the three screws that were unscrewed.

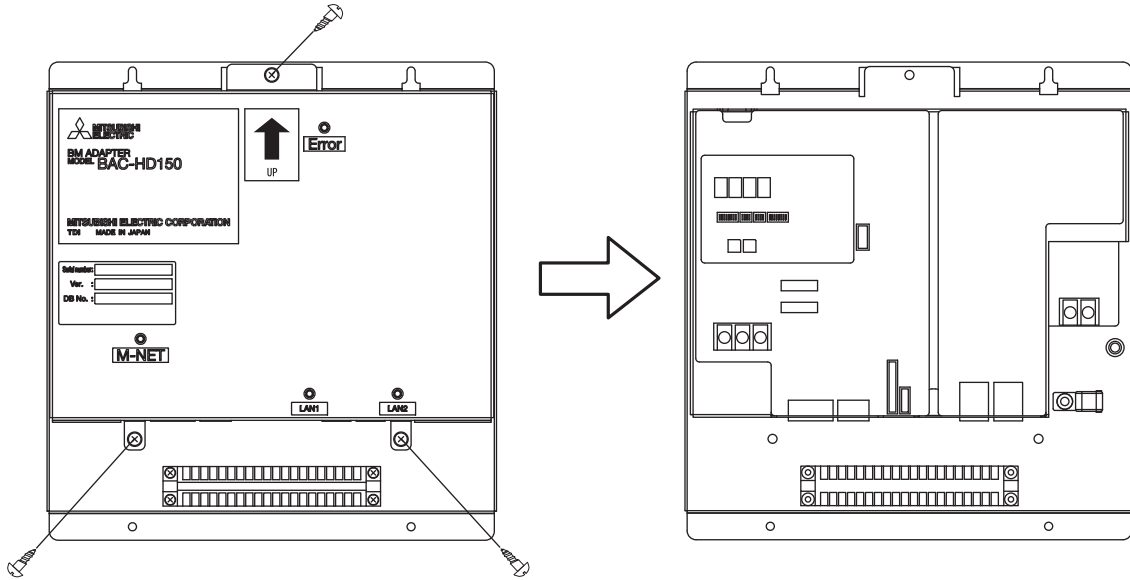

### 5-2. Connecting the power cable and protective earth cable

- Connect the power cable and the protective earth cable as shown in the figure below. Use an M3.5 ring terminal to the power cable, and connect an M4 ring terminal to the protective earth cable before connecting them to their corresponding terminals (power supply terminal block or protective earth terminal).
- Be sure to connect the N/L2 phase of the power cable to the N/L2 side of the power supply terminal block (TB1).
- Secure cables with cable clamps.

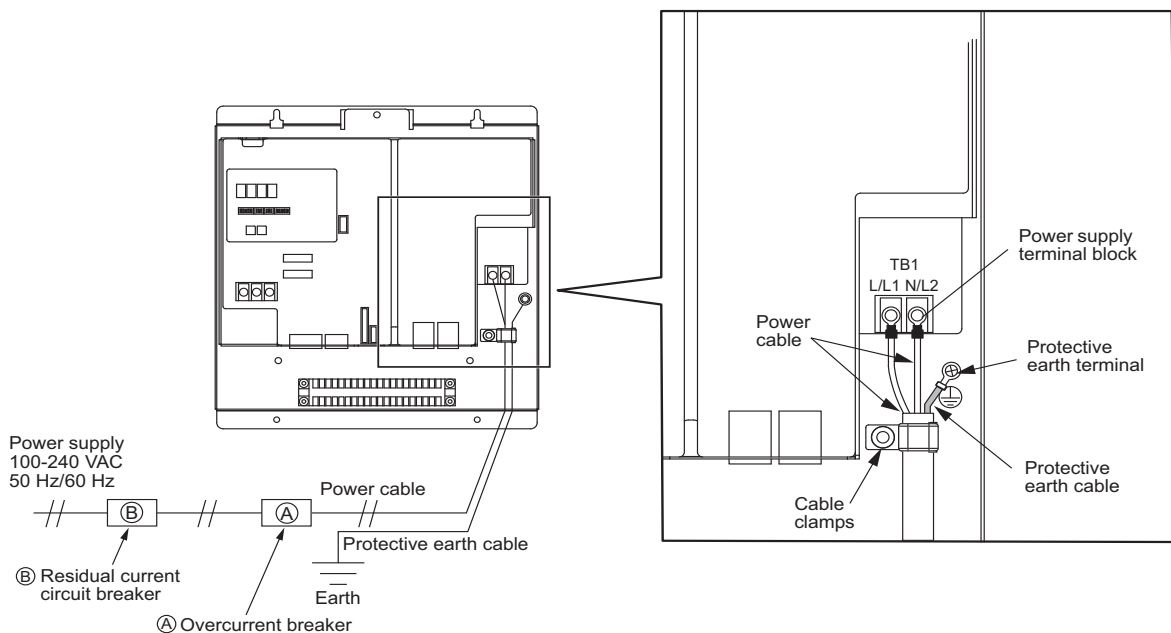

- ⚠ CAUTION**
- Install an overcurrent breaker and a residual current circuit breaker for the power wire to each BAC-HD150 unit. Use a bipolar breaker (2P2E) with a minimum contact distance of 3 mm (1/8 in.).
  - Install a breaker for each BAC-HD150 so that turning off the power to one BAC-HD150 will not affect the rest of the devices in the system.
  - When using a fuse instead of an overcurrent breaker, use it in combination with a main switch (Rated current: 3 A).

### 5-3. Connecting the M-NET transmission lines

**CAUTION** • In an air conditioner system has more than 1 Outdoor units, System controller receiving transmission power through TB7 on one of the Outdoor unit would have a risk that the connected Outdoor units failure would stop power supply to System controller, and disrupt the whole system.

#### (1) System in which BAC-HD150 is connected to the M-NET line

Connect the M-NET transmission lines and the power jumper as shown in the figure below.

① To supply power to the M-NET transmission line from the BAC-HD150

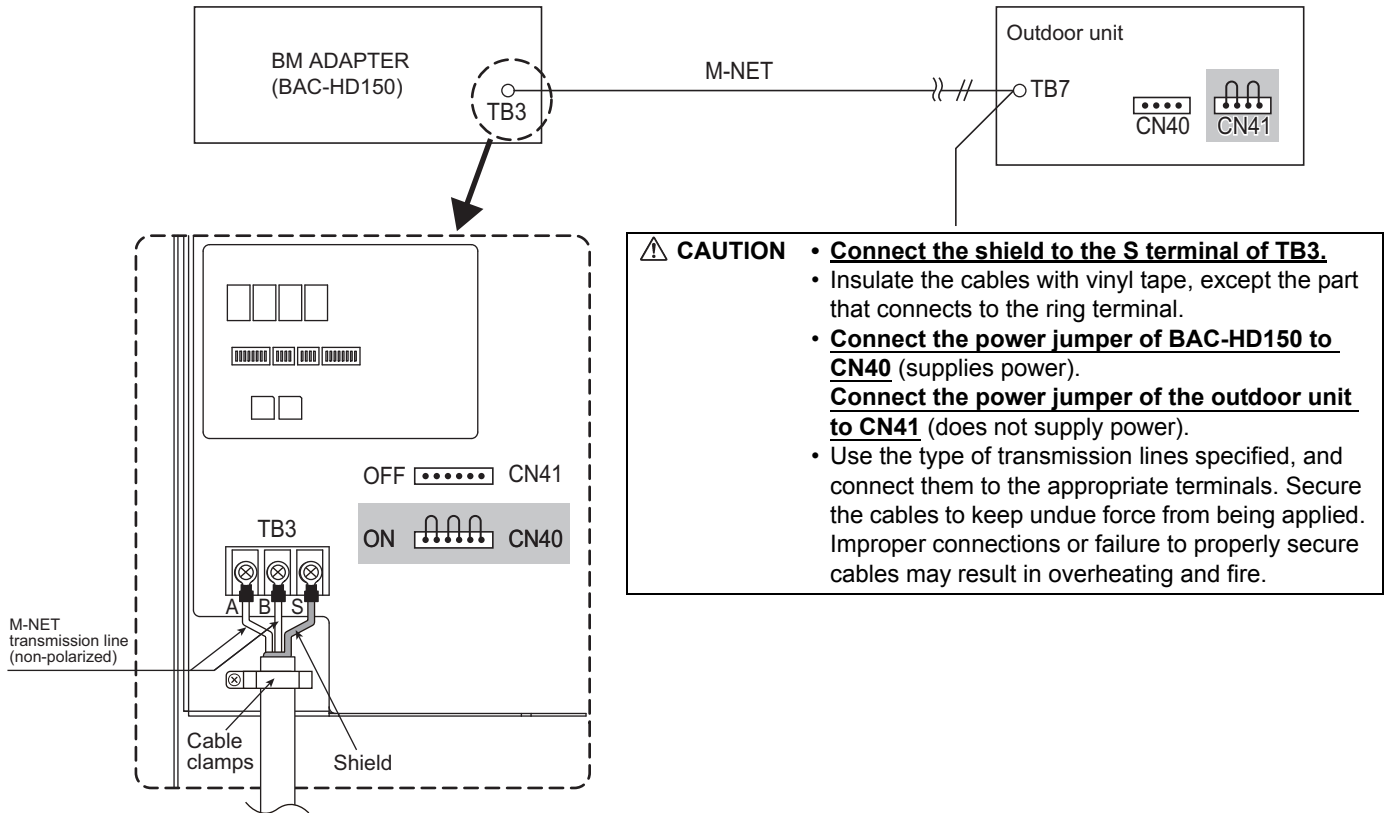

② To not supply power to the M-NET transmission line from the BAC-HD150

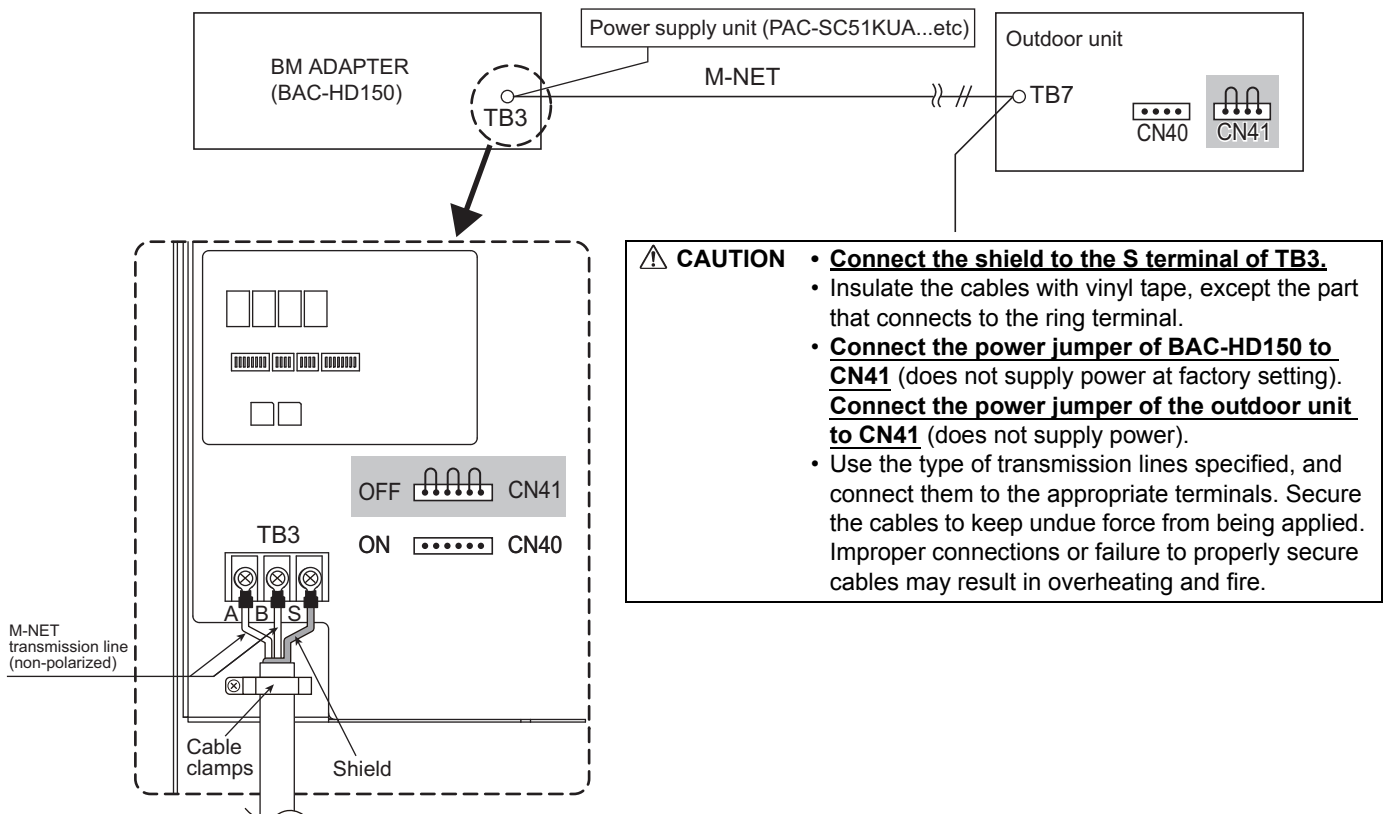

(2) System in which BAC-HD150 is connected to the expansion controller (PAC-YG50ECA)(system in which BAC-HD150 is not connected to the M-NET)

It is not necessary to connect the M-NET transmission line to the TB3 on BAC-HD150. Connect the power jumper as shown in the figure below.

Refer to section 5-4. "Connecting the LAN cable" for how to connect PAC-YG50ECA.

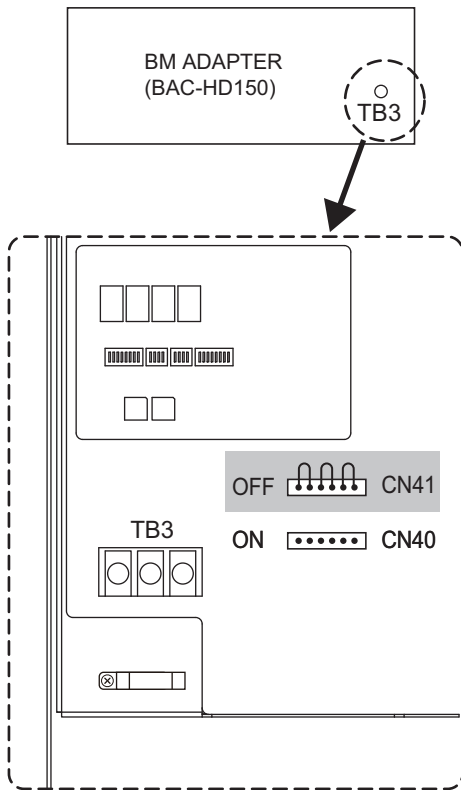

**CAUTION** • Leave the power jumper of BAC-HD150 connected to CN41 (Does not supply power at factory setting).  
Refer to the PAC-YG50ECA Installation/Instructions Manual for where to connect the power jumper of the expansion controllers and outdoor units.

### 5-4. Connecting the LAN cable

- Make sure that the LAN cable is long enough to reach the LAN1 and LAN2 connectors on the BAC-HD150. Leave the LAN cable disconnected until all the initial settings for the BAC-HD150 (IP address setting etc.) have been completed.
- Connect the BAC-HD150 (LAN1) and the Building Management System via a HUB.
- Expansion controllers (PAC-YG50ECA), when used, must be connected to the LAN2 of BAC-HD150 via a HUB.
- The maximum distance between the HUB and BAC-HD150 is 100 m (328 ft).

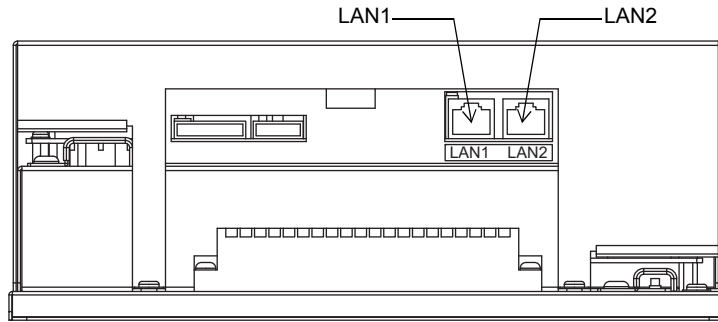

(1) LAN connection example of a system in which BAC-HD150 is connected to the M-NET line

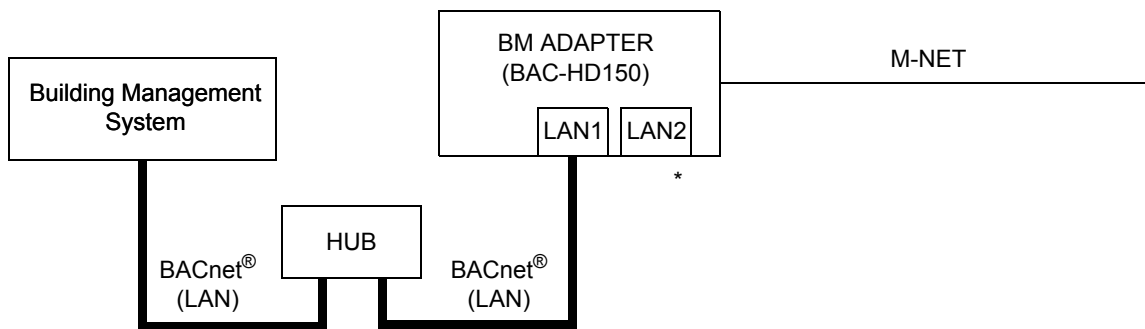

\* LAN2 of BAC-HD150 will not be used.

(2) LAN connection example of a system in which BAC-HD150 is connected to the expansion controller (PAC-YG50ECA)

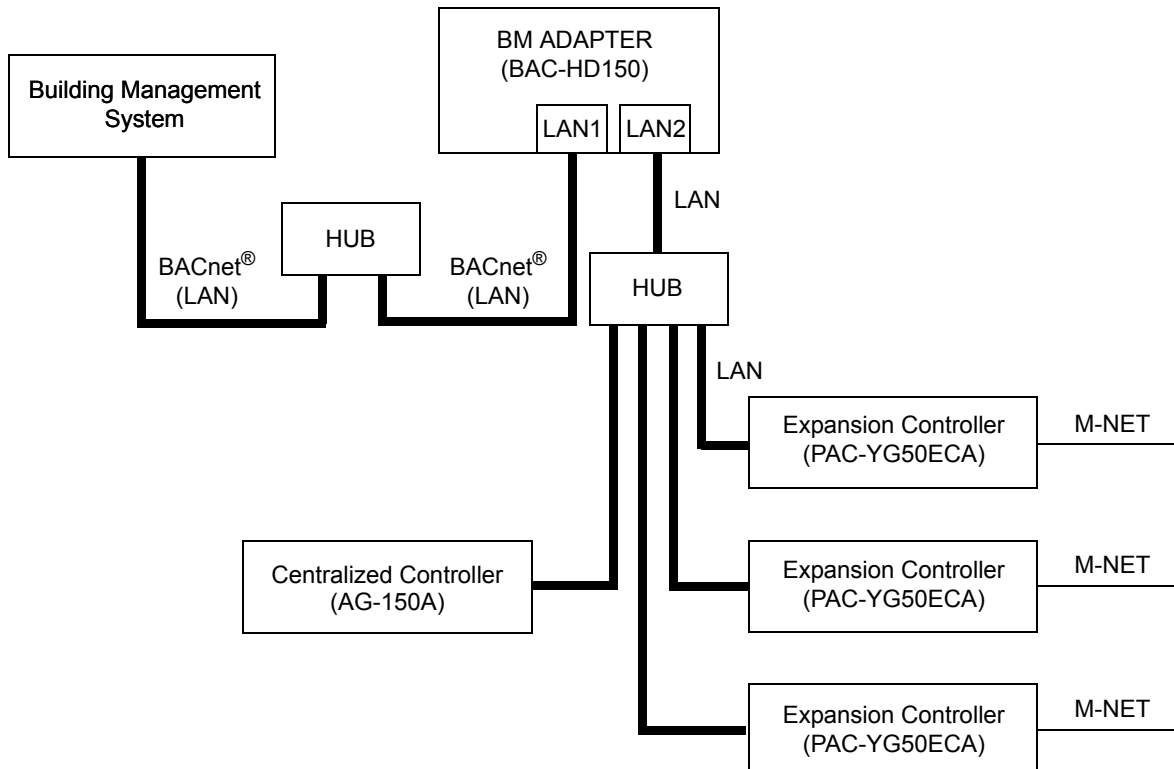

**CAUTION** • Connect the BACnet® building management system to LAN1 port and the expansion controllers (PAC-YG50ECA) to LAN2 port, and be careful not to mix them up.

**⚠ CAUTION** • Install the LAN cable before installing the unit, and route the cable in the same way as the M-NET transmission lines.  
• Connect the BAC-HD150 to a private network. Use a security device such as a VPN router when connecting to the Internet. (Without a proper security measure in place, the air conditioning system is vulnerable to access from unauthorized users.)

## 6 Making the initial settings

**Note** Refer to the BAC-HD150 Instructions Book and the Setting Tool Instructions Book for how to make the initial settings for the BAC-HD150.  
Refer to the PAC-YG50ECA Installation/Instructions Manual for how to use the expansion controller.

### 1. Turning on the power

Disconnect the LAN cable for connection to the BACnet<sup>®</sup> before turning the power on for the first time.  
There is a possibility that the IP address of the unit is already used by another device that is connected to the BACnet<sup>®</sup>.

### 2. Initial settings

Make the initial setting using the Setting Tool after turning on the power to the BAC-HD150.

Some of the items that require initial settings include BAC-HD150 address and air conditioning system related items.

- IP address of BAC-HD150 (The factory setting for LAN1 is "192.168.1.254." The factory LAN2 setting is "192.168.200.212".)
- M-NET address of BAC-HD150 (The factory setting is "0".)
- Group configuration for the air conditioning system

Refer to the BAC-HD150 Instructions Book and the Setting Tool Instructions Book for detailed instructions for how to make the initial settings.

## 7 Test run

**Note** Refer to the BAC-HD150 Instructions Book and the Installation Manuals that came with the air conditioning units for how to perform a test run for the BAC-HD150.

- Refer to the Installation Manuals that came with the air conditioning units for how to perform a test run.
- Perform a test run for the Mitsubishi Electric air conditioning system and confirm proper operation before connecting to the building management system and performing a test run. (Refer to the BAC-HD150 Instructions Book for details.)

**NOTE:**

This equipment has been tested and found to comply with the limits for a Class B digital device, pursuant to Part 15 of the FCC Rules. These limits are designed to provide reasonable protection against harmful interference in a residential installation. This equipment generates, uses and can radiate radio frequency energy and, if not installed and used in accordance with the instructions, may cause harmful interference to radio communications.

However, there is no guarantee that interference will not occur in a particular installation.

If this equipment does cause harmful interference to radio or television reception, which can be determined by turning the equipment off and on, the user is encouraged to try to correct the interference by one or more of the following measures:

- Reorient or relocate the receiving antenna.
- Increase the separation between the equipment and receiver.
- Connect the equipment into an outlet on a circuit different from that to which the receiver is connected.
- Consult the dealer or an experienced radio / TV technician for help.



---

This product is designed and intended for use in the residential,  
commercial and light-industrial environment.

The product at hand is  
based on the following  
EU regulations:

- Low Voltage Directive 2006/95/EC
- Electromagnetic Compatibility Directive,  
2004/108/EC
- Restriction of Hazardous Substances  
2011/65/EU

Please be sure to put the contact address/telephone number on  
this manual before handing it to the customer.

## **MITSUBISHI ELECTRIC CORPORATION**

**HEAD OFFICE:** TOKYO BLDG., 2-7-3, MARUNOUCHI, CHIYODA-KU, TOKYO 100-8310, JAPAN

**Authorized representative in EU:** MITSUBISHI ELECTRIC EUROPE B.V.

HARMAN HOUSE, 1 GEORGE STREET, UXBRIDGE, MIDDLESEX UB8 1QQ, U.K.

WT05543X03  
Printed in Japan  
Recycled Paper